

ISSUE DATE: 11/06

**INSTRUCTIONS FOR ASSEMBLY,
INSTALLATION AND OPERATION,
MAINTENANCE MANUAL AND
REPLACEMENT PARTS LIST
FOR:**

GHF SERIES

GAS HOT FOOD TABLES

LOW TEMP
MANUFACTURING COMPANY

DIVISION OF LOW TEMP INDUSTRIES, INC.
9192 TARA BLVD. – JONESBORO, GA 30236
PO BOX 795 – JONESBORO, GA 30237
TELEPHONE: (770) 478-8803

CUSTOM FABRICATORS OF STAINLESS STEEL FOOD SERVICE EQUIPMENT

INSPECTION

UPON RECEIPT OF ITEM, CRATE SHOULD BE INSPECTED FOR VISUAL DAMAGE SHOULD BE REPORTED IMMEDIATELY TO THE DELIVERING CARRIER. RETAIN MANUAL FOR FUTURE REFERENCE

FOR YOUR SAFETY

DO NOT STORE OR USE GASOLINE OR OTHER FLAMABLE VAPORS AND LIQUIDS IN THE VICINITY OF THIS OR ANY OTHER APPLIANCE

WARNING: IMPROPER INSTALLATION, ADJUSTMENT ALTERATION, SERVICE OR MAINTENANCE CAN CAUSE PROPERTY DAMAGE, INJURY OR DEATH. READ THE INSTALLATION, OPERATING AND MAINTENANCE INSTRUCTIONS THOROUGHLY BEFORE INSTALLING OR SERVICING THIS EQUIPMENT

ELECTRICAL GROUNDING INSTRUCTIONS

THIS APPLIANCE IS EQUIPPED WITH A THREE-PRONG (GROUNDING) PLUG FOR YOUR PROTECTION AGAINST SHOCK HAZARD AND SHOULD BE PLUGGED DIRECTLY INTO A PROPERLY GROUNDED THREE-PRONG RECEPTACLE. DO NOT CUT OR REMOVE TIE GROUNDING PRONG FROM THIS PLUG

INSTALLATION

THE HOT FOOD TABLE IS A SELF CONTAINED UNIT FOR DISPENSING OR HOLDING HOT FOOD. WHERE A GROUP OF UNITS CAN BE ARRANGED END TO END FORMING A CAFETERIA SERVING LINE.

PLACE TABLE IN SERVING LINE OR NEEDED POSITION. AN ADEQUATE CLEARANCE MUST BE MAINTAINED FOR SERVICING AND PROPER OPERATION. CONNECT TO PROPER GAS LINE AND CHECK FOR LEAKS USING SOAP SOLUTION. THIS UNIT IS NORMALLY SHIPPED FROM THE FACTORY EQUIPPED FOR NATURAL GAS. CHECK MARKINGS ON THE SPECIFIC UNIT BEFORE CONNECTION TO SUPPLY LINES. THIS UNIT IS APPROVED FOR USE ON COMBUSTIBLE FLOORS. A MINIMUM CLEARANCE OF 6 INCHES FROM COMBUSTIBLE CONSTRUCTION AT THE FRONT AND BACK MUST BE MAINTAINED. THE AIR VENTILATION HOLES MUST BE KEPT CLEAR FROM OBSTRUCTION TO ALLOW FOR ADEQUATE AIR FLOW. FAILURE TO DO SO WILL CAUSE INCOMPLETE COMBUSTION AND CARBON MONOXIDE WILL FORM. THE APPLIANCE AREA IS TO BE KEPT FREE FROM COMBUSTIBLES.

INSTALLATION MUST CONFORM WITH LOCAL CODES, OR IN THE ABSENCE OF LOCAL CODES, WITH THE NATIONAL FUEL GAS CODE, ANSI Z223.1, NATURAL GAS INSTALLATION CODE, CAN/CGA-B149.1 , OR THE PROPANE INSTALLATION CODE, CAN/CGA-B149.2, AS APPLICABLE

WHEN OPTIONAL ELECTRICAL DEVICES ARE INSTALLED THEY MUST BE ELECTRICALLY GROUNDED IN ACCORDANCE WITH LOCAL CODES, OR IN THE ABSENCE OF LOCAL CODES, WITH THE NATIONAL ELECTRICAL CODE, ANSI/NFPA 70, OR THE CANADIAN ELECTRICAL CODE, CSA C22.2, AS APPLICABLE

INSTALLATION (CONT.)

FOR AN APPLIANCE EQUIPPED WITH CASTERS, INSTRUCTIONS THAT (1) THE INSTALLATION SHALL BE MADE WITH A CONNECTOR THAT COMPLIES WITH THE STANDARD FOR CONNECTORS FOR MOVABLE GAS APPLIANCES, ANSI Z21.69 OR CONNECTORS FOR MOVEABLE GAS APPLIANCES, CAN/CGA-6.16, AND A QUICK-DICONNECT DEVICE THAT COMPLIES WITH THE STANDARD FOR QUIICK-DISCONNECT DEVICES FOR USE WITH GAS FUEL, ANSI Z21.41, OR QUICK-DISCONNECT DEVICES FOR USE WITH GAS FUEL, CSA-6.9, (2) ADEQUATE MEANS MUST BE PROVIDED TO LIMIT THE MOVEMENT OF THE APPLIANCE WITHOUT DEPENDING ON THE CONNECTOR AND THE QUICK-DISCONNECT DEVICE OR ITS ASSOCIATED PIPING TO LIMIT THE APPLIANCE MOVEMENT AND (3) THE LOCATION(S) WHERE THE RESTRAINING MEANS MAY BE ATTACHED TO THE APPLIANCE SHALL BE SPECIFIED

LIGHTING INSTRUCTIONS

- 1. FOR WET OPERATION FILL RECEPTACLE WITH WATER TO CREASE ON SIDE OF PAN.**
- 2. TURN THERMOSTATS TO OFF, WAIT FIVE (5) MINUTES FOR ESCAPE OF ANY ACCUMULATED GAS**
- 3. PUSH AND HOLD RED BUTTON FULLY IN. LIGHT PILOT. HOLD BUTTON DOWN FOR ONE (1) MINUTE. REPEAT IF PILOT GOES OUT.**
- 4. SET PILOT FLAME TO ½ INCH HEIGHT WITH ADJUSTMENT SCREW PROVIDED ON PILOT LINE.**
- 5. TURN THERMOSTAT TO DESIRED TEMPERATURE. BURNER SHOULD IGNITE.**

NOTE: VENTILATION HOLES AND THE AIR FLOW PATH TO BURNERS SHOULD BE KEPT FREE OF OBSTRUCTIONS AT ALL TIMES. AN ADAQUATE AIR SUPPLY SHOULD BE MAINTAINED AROUND THE COUNTER TO ENSURE COMPLETE COMBUSTION AND VENTING OF FLUE GASES. FAILURE TO DO SO WILL CAUSE CARBON MONOZIDE TO BE FORMED AND REDUCE THE EFFICIENCY OF THE UNIT.

UNIT SHOULD BE INSTALLED IN ROOM WITH ADAQUATE AIR SUPPLY.

SHUT DOWN

AT THE END OF THE DAY OR FOOD SERVING PERIOD, TURN THERMOSTATS TO THE “OFF” POSTION AND WHEN PILOT LIGHT GOES OUT DISCONNECT GAS LINE.

WHEN THE APPLIANCE IS SUPPLIED ON CASTERS AND DISCONNECTED FROM GAS SUPPLY AND MOVE BE SURE TO RECONNECT THE RESTRAINT AND RETURN APPLIANCE BACK TO ITS ORIGINALLY INSTALLED POSITION.

OPERATOR'S INSTRUCTIONS

SINCE THE FOOD WARMING RECEPTACLE IS DESIGNED FOR WARMING OR HOLDING PRECOOKED FOOD, IT WILL NOT OVERCOOK WHEN PROPERLY USED.

PLACE FOOD IN HOLDING CONTAINER INTO RECEPTACLE. KEEP FOOD COVERED WHEN NOT SERVING.

EXACT DIAL SETTING TO MAINTAIN DESIRED FOOD TEMPERATURE WILL VARY WITH THE CHARACTER OF THE FOOD. THE MOST SATISFACTORY TEMPERATURE SETTING MUST BE DETERMINED BY EXPERIENCE.

FOR WET OPERATION IT IS RECOMMENDED TO FILL RECEPTACLE WITH WATER TO A DEPTH OF $\frac{1}{2}$ INCH AS INDICATED BY THE WATER FILL LINE BEFORE OPERATING UNIT.

NOTE: DO NOT PUT COLD WATER INTO A HOT RECEPTACLE. THIS CAN CAUSE DAMAGE TO THE RECEPTACLE AND MAY CAUSE LEAKS.

- 1. DRY OPERATION: WHEN THE FOOD WARMING RECEPTACLE IS USED DRY, FOOD SPILLAGE ON THE HOT SURFACE WILL BURN AND STICK. THE SAME COMMERCIAL CLEANERS USED ON STAINLESS STEEL KITCHEN UTENSILS MAY BE USED TO CLEAN THE RECEPTACLE. WASH THE INTERIOR SURFACE WITH WATER AND A MILD DETERGENT TO REMOVE MILD DISCOLORATION. RINSE WITH PLAIN WATER AND DRY WITH AN ABSORBENT CLOTH. THE BOTTOM OF THE RECEPTACLE MAY TAKE ON A STRAW COLORED APPEARANCE WHEN USED DRY. THIS IS DUE TO THE INTENSE HEAT WHICH CAUSES THE STAINLESS STEEL TO DISCOLOR. THE DISCOLORATION WILL NOT COME OFF PROBLEMS WITH NORMAL CLEANING, BUT POSES NOT.**

- 2. WET OPERATION: IF THE FOOD WARMING RECEPTACLE IS USED WET, ALL SURFACES ARE COVERED WITH A THIN FILM OF WATER. FOOD SPILLAGE INTO THE RECEPTACLE WILL NOT STICK OR BURN DUE TO THE WATER. TO CLEAN THE RECEPTACLE, DRAIN THE WATER BY OPENING THE DRAIN VALVE LOCATED UNDER THE CABNET WASH THE RECEPTACLE WITH A MILD DETERGENT AND WATER, RINSE AND DRY WITH A CLEAN, ABSORBENT CLOTH.**

- 3. THE FOOD WARMING RECEPTACLE IS MADE OF STAINLESS STEEL, HOWEVER, USE CARE AND COMMON SENSE DURING THE CLEANING OPERATION. HEAVY OBJECTS SHOULD NOT BE DROPPED INTO THE RECEPTACLE. PROPER USE AND PROPER CLEANING WILL INSURE SERVICE LIFE OF RECEPTACLES.**

- 4. CONTROL KNOBS: TO CLEAN THE CONTROL KNOB, PULL IT OUTWARD TO REMOVE IT FROM THE SHAFT. WASH THE KNOB WITH MILD SOAP AND WATER, RINSE AND DRY WITH A DRY CLOTH. DO NOT USE ABRASIVE CLEANERS ON THE PLASTIC SURFACE.**

MAINTENANCE INSTRUCTIONS

ALL MAINTENANCE WORK SHOULD BE PERFORMED BY A QUALIFIED SERVICE PERSON OR CONTACT THE FACTORY OR FACTORY REPRESENTATIVE.

TO REMOVE OR REPLACE THE PILOT ASSEMBLY

- 1. TURN GAS VALVE OFF, WAIT FIVE (5) MINUTES FOR GAS TO ESCAPE.**
- 2. REMOVE THE NUT AND BOLT ASSEMBLY HOLDING THE PILOT TO THE STAINLESS STEEL BRACKET, DISCONNECT THE TUBE UNDER PILOT.**
- 3. DISCONNECT THERMOCOUPLE FROM THE SAFETY VALVE.**

NOTE: WHEN REPLACING THE THERMOCOUPLE, THE NUT SHOULD BE STARTED AND TURNED ALL THE WAY BY HAND. AND ADDITIONAL QUARTER TURN WITH A SMALL WRENCH WILL BE SUFFICIENT.

****CAUTION****

OVERTIGHTENING MAY DAMAGE THE THERMOCOUPLE OR MAGNET.

TO REMOVE OR REPLACE THE THERMOSTAT

- 1. TURN MAIN GAS VALVE OFF. WAIT FIVE (5) MINUTES FOR THE GAS TO ESCAPE.**
- 2. DISCONNECT THE THERMOCOUPLE, GAS LINE TO THE PILOT AND THE GAS LINE TO THE BURNER.**
- 3. REMOVE BRACKET ON CAPILLARY BULB INSIDE STAINLESS STEEL PAN AND PULL CAPILLARY DOWN THROUGH THE PAN.**
- 4. DISCONNECT THERMOSTAT BY UNSCREWING PIPE FITTING COMING FROM PILOT VALVE FITTING UNDER THE THERMOSTAT.**

TO REMOVE OR REPLACE THE SAFETY VALVE

- 1. USE THE SAME PROCEDURE AS LISTED ABOVE.**
- 2. AFTER ALL GAS LINES ARE DISCONNECTED SAFETY VALVE CAN BE REMOVED BY UNSCREWING PIPE FITTING.**

NOTE: WHEN REPLACING THE SAFETY VALVE OR THERMOSTAT TAKE CARE TO ALIGN ALL FITTINGS AND VALVES AS THEY WERE ORIGINALLY. MAKE SURE ALL FITTINGS ARE FREE OF DIRT AND SCALE. USE AN APPROVED PIPE SEALING COMPOUND. TAKE CARE TO PREVENT PIPE SEALING COMPOUND FROM ENTERING THE LINE OR VALVE.

CONVERSION INSTRUCTION FOR
LOW TEMP MANUFACTURING COMPANY
SERIES GHF-GAS HOT FOOD TABLES

WARNING: ALL WORK PERFORMED ON THIS UNIT SHOULD BE DONE BY QUALIFIED SERVICE PERSONEL.

NOTE! ALL UNITS ARE SHIPPED FROM THE FACTORY EQUIPPED FOR NATURAL GAS UNLESS OTHERWISE SPECIFIED. CHECK THE NAME PLATE AND THE NOTICE TAG ATTACHED TO THE MANIFOLD FOR VERIFICATION.

**EACH CONVERSION KIT COMES COMPLETE WITH:
ONE (1) MAXITROL RV-35A CLASS II REGULATOR SET AT 10 INCH WATER COLUMN PRESSURE.**

FOUR (4), FIVE (5) OR SIX (6) SOLARFLO PROPANE 74-651B BURNER HEADS COLOR CODED BLACK.

FOUR (4), FIVE (5) OR SIX (6) ROBERTSHAW .008 ORFICE SPUDS.

- 1. DISCONNECT ALL GAS FROM THE SYSTEM. BE SURE THAT ALL ACCUMLATED GAS IS OUT OF THE SYTEM BEFORE STARTING.**
- 2. DISCONNECT THE RV-35A CLASS I REGULATOR FROM THE MANIFOLD. AND REPLACE WITH THE RV-35A CLASS II REGULATOR SUPPLIED WITH THE KIT.**
- 3. CAREFULLY UNSCREW THE NATURAL 63-651BBURNER HEADS FROM THE MOUNTING POSITION AND REPLACE WITH THE PROPANE 74-651B BURNER HEADS. TAKE CARE NOT TO DAMAGE THE AIR INLETS HOLES IN THE BASE OF THE BURNERS.**
- 4. DISCONNECT THE PILOT LINE AT THE PILOT BURNER BASE. REMOVE THE SPUD ORIFICE WHICH IS PUSHED UP IN THE BASE OF THE PILOT BURNER. REPLACE WITH THE .008 PILOT SPUD SUPPLIED WITH THE KIT.**
- 5. REPEAT STEPS 3 AND 4 FOR EACH FURNER ASSEMBLY IN THE UNIT.**
- 6. RECONNECT TO MAIN GAS LINE TO THE SYSTEM**
- 7. TURN THE GAS SUPPLY ON AND CHECK THE MANIFOLD FOR LEAKS. CHECK EITHER WITH A SOAP SOLUTION OR AN OPEN FLAME.**
- 8. FOLLOW OPERTING INSTRUCTIONS ON THE NAME PLATE TO START UP.**

BJWA Gas Thermostat



The BJWA control is a combination gas cock and by-pass type thermostat. It is available with both by-pass and pilot adjustments. With the BJWA the gas is turned on, and the temperature setting made, with a single turn of the dial.

The BJWA is available for a wide variety of applications. Typical applications are ranges and griddles.

Design Features

- Highly adaptable because of multiple orientation and number of outlets
- Mounted, via flange nipple, above or below the manifold
- Available with various temperature ranges
- Front adjustment for pilot and by-pass
- Modulating seat action
- Variety of applications from griddles to ovens to fryers
- Bulb and capillary available in copper, nickel plated copper, and nickel plated steel (nickel plated steel most common)

Specifications

- Ambient temperature:
32°F (0°C) to 350°F (177°C)
- Maximum inlet pressure: 0.5 PSI
- Capacity (Natural Gas):
to 70,000 BTU/HR
- Agency Certification Numbers:
AGA/CGA T2765005
British Gas plc EC Product
Identification No.: C87AR12

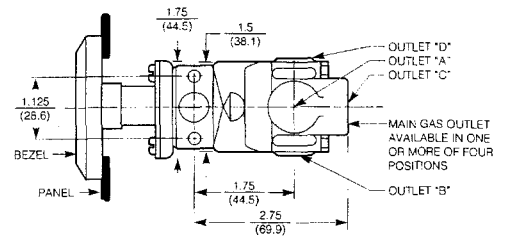
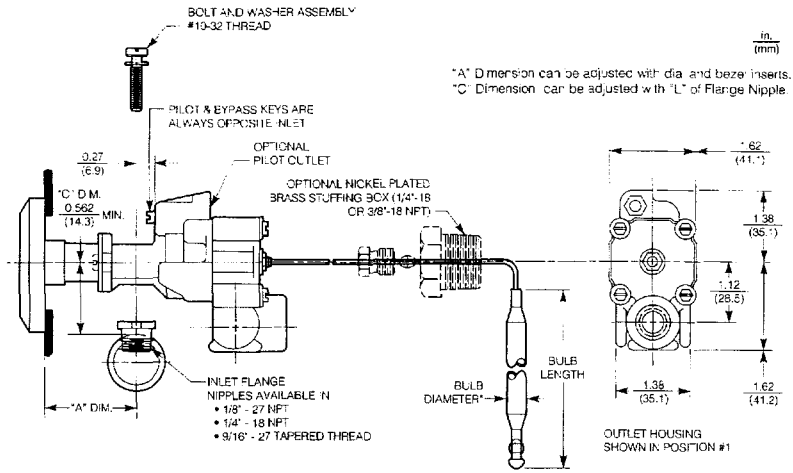

*AVAILABLE BULB DIAMETERS				
Inches	0.187**	0.250	0.312	0.375
(mm)	(4.8)	(6.4)	(7.9)	(9.5)
**0.187 inch diameter bulb is most common.				
AVAILABLE CAPILLARY LENGTHS				
24 to 120 in 12" increments				
(609.6 to 3048 in 304.8mm increments)				

Outlet Housing Positions

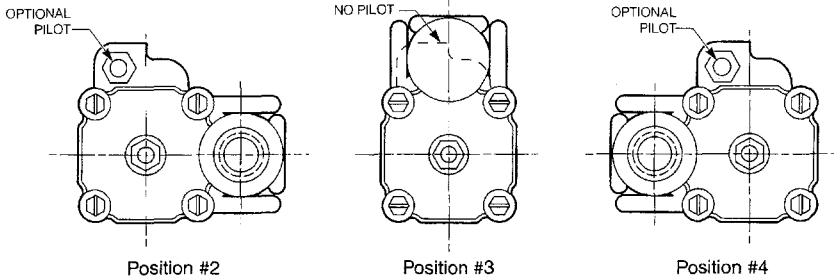

Bezel Subassemblies

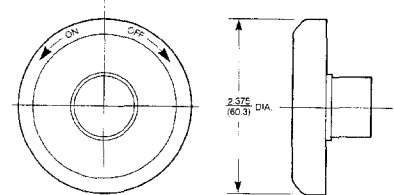

Dial Subassemblies

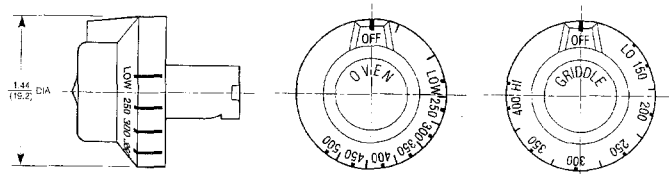

Drawing No.	"D" Dim.	"L" Dim.	Thread size
Z558130700	0.250	0.365	1/8"-27 NPT
Z558131200	0.312	0.365	9/16"-27 Taper Thd.
Z558131400	0.250	0.468	1/8"-27 NPT
Z558132200	0.312	0.468	1/4"-18 NPT
Z558131800	0.312	0.468	9/16"-27 Taper Thd.
Z558131300	0.250	0.593	1/8"-27 NPT
Z558131100	0.312	0.593	1/4"-18 NPT
Z558130900	0.312	0.593	9/16"-27 Taper Thd.

Contact Invensys for other dial layouts.

Inlet Flange Nipples

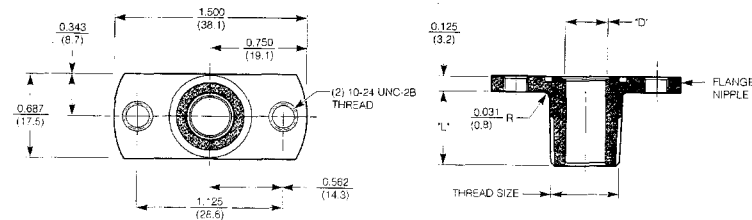

Application Responsibility
 Invensys Appliance Controls, as supplier, will comply with those agreed to drawing requirements and specifications that define this product. Suitability for any specific application is the responsibility of the purchaser.

Information subject to change without notice.



H15 Series BASO® Automatic Shutoff Pilot Gas Valve

BASO Gas Products LLC

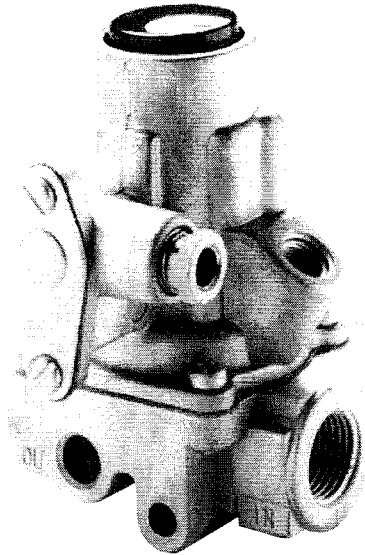

Description

The H15 Series automatic pilot valves provide safe lighting and complete shutoff of pilot and main burner gas in the event that the flame heating the thermocouple is extinguished. They are designed for standing pilot applications and can be used with natural gas and LP gas, at pressures up to 0.5 psi. Typical applications include commercial cooking equipment, heaters, kilns, dishwashing equipment, industrial ovens, and similar applications. Sizes range from 3/8 in. to 1 in. NPT and both standard and high temperature models are available. The optional rotor "B" valve allows for pilot flame adjustment.

Specifications

- Maximum inlet pressure is 0.5 psi
- Permissible ambient (surface) temperature is -30 to 175°F (-34 to 80°C) models without rotor valve
32 to 175°F (0 to 80°C) models with rotor valve
-20 to 300°F (-29 to 150°C) H15_B and H15_R models only
- High temperature model allows for use in valve surface temperatures up to 300°F

Agency Listing

- CSA (AGA/CGA) Certificate Number 229521-1656080
- Australian Gas Association Certificate Number 4236
- EN/EC Type Examination Certificate Number E3735 (models without rotor B valve only)
- UL Recognized File Number MH2926 (H15CA, and DA models only)

To Order

To order genuine BASO products, call 1-877-227-6427 (1-877-BASOGAS). Specify the code number from the following selection chart.

Other models may be made available depending upon customer requirements. Contact BASO Gas Products for availability of products not shown.

Selection Chart

Code Number	Inlet and Outlet Female NPT	Natural Gas Capacity Btu/hr at 1 in. Pressure Drop	Pilot Tap (in.)	Pressure Tap	Pilot Gas Flow/Rotor "B" Valve
H15AB-3	3/8 in. x 3/8 in.	172,000	1/8-27 NPT over inlet	None	Internal/No
H15AR-3		163,000	1/8-27 NPT over inlet	None	External/No
H15CA-1		322,000	1/8-27 NPT over inlet	None	Internal/No
H15CB-2	1/2 in. x 1/2 in.	322,000	1/8-27 NPT over inlet	None	Internal/No
H15CQ-3		322,000	(2) 1/4 cc left	None	External/No
H15CQ-6		322,000	(2) 1/4 cc right	1/8-27 NPT left and right	External/No
H15DA-3*	3/4 in. x 3/4 in. *packaged with 3/4 to 1/2 in. and 3/4 to 3/8 in. reducer bushings	402,000	1/8-27 NPT over inlet	None	Internal/No
H15DA-4		402,000	1/8-27 NPT left and right	1/8-27 NPT left and right	Internal/No
H15DB-1		402,000	1/8-27 NPT over inlet	None	Internal/No
H15DQ-2		402,000	(2) 1/4 cc right	1/8-27 NPT left and right	External/No
H15DH-3*		402,000	1/4 cc over outlet	None	Internal/Yes
H15EQ-3*		540,000	(2) 1/4 cc right	None	External/No
H15FA-1	1 in. x 1 in.	610,000	1/8-27 NPT over inlet	None	Internal/No
H15FQ-1		610,000	(2) 1/4 cc right	None	External/No
H15HQ-5		172,000	1/4 cc left	None	External/No
H15HR-2	3/8 in. x 3/8 in.	172,000	(2) 3/16 cc left	None	External/No
H15HR-6		172,000	(2) 1/4 cc right	None	External/No

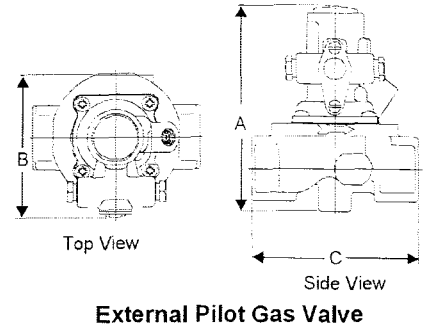
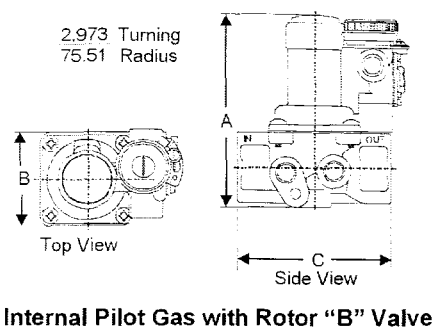
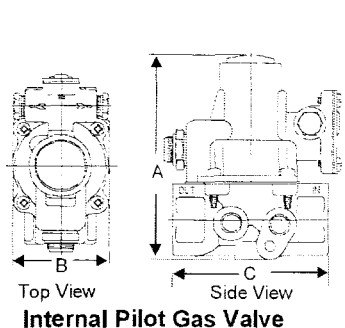

H15 Dimensions

Dimensions

Code Number	A Height		B Width		C Length	
	In.	mm	In.	mm	In.	mm
H15AB-3	3.69	94	1.81	46	2.90	74
H15AR-3	3.69	94	1.93	49	2.90	74
H15CA-1	3.93	100	1.93	49	3.40	86
H15CB-2	3.93	100	1.93	49	3.40	86
H15CQ-3	3.93	100	1.93	49	3.40	86
H15CQ-6	3.93	100	1.93	49	3.40	86
H15DA-3	3.93	100	1.93	49	3.40	86
H15DA-4	3.93	100	1.93	49	3.40	86
H15DB-1	3.93	100	1.93	49	3.40	86
H15DQ-2	3.93	100	1.93	49	3.40	86
H15DH-3	4.62	117	3.00	76	3.50	89
H15EQ-3	4.12	105	3.00	74	2.56	65
H15FA-1	4.62	117	2.68	68	3.50	89
H15FQ-1	4.62	117	3.00	76	3.50	89
H15HQ-5	3.81	97	2.59	66	2.56	65
H15HR-2	3.81	97	2.59	66	2.56	65
H15HR-6	3.81	97	2.59	66	2.56	65

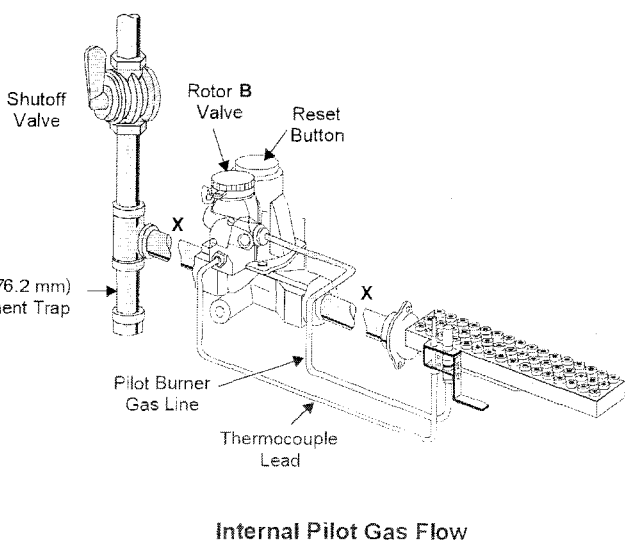
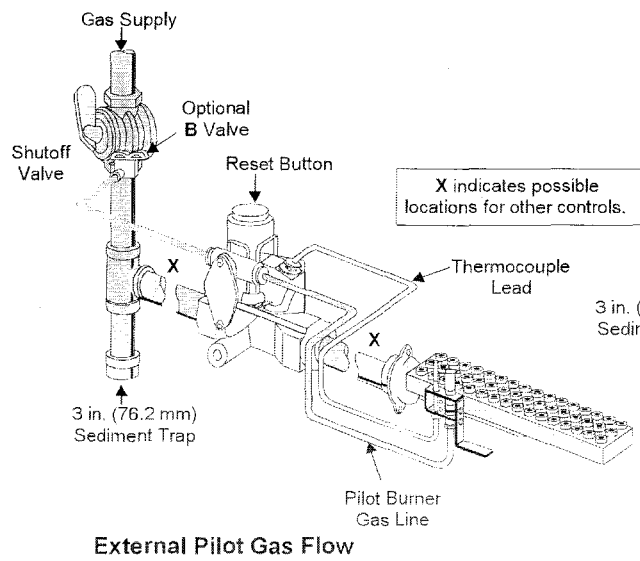

Typical H15 Installation

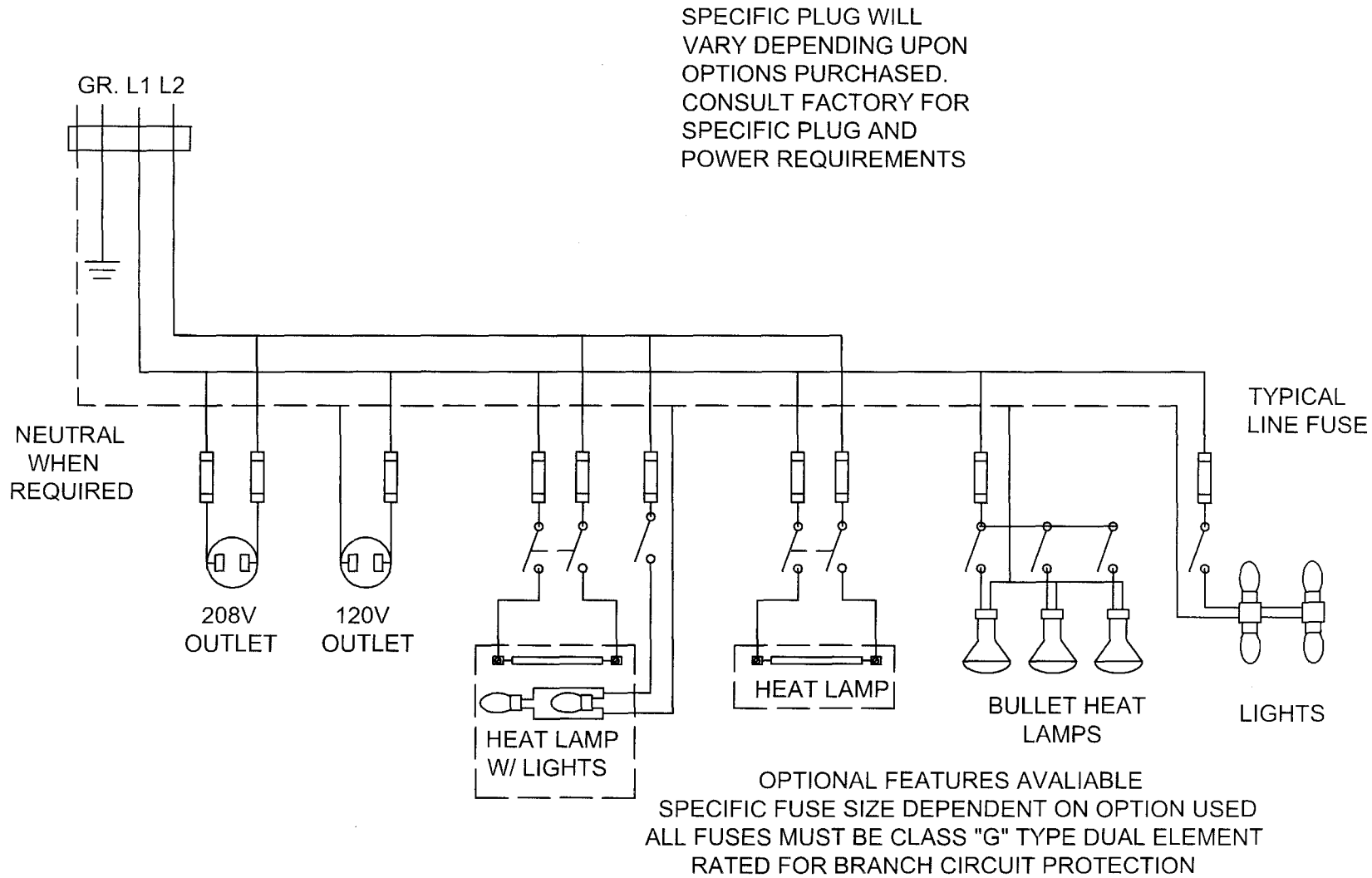

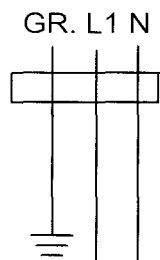

SPECIFIC PLUG WILL VARY DEPENDING UPON OPTIONS PURCHASED. CONSULT FACTORY FOR SPECIFIC PLUG AND POWER REQUIREMENTS

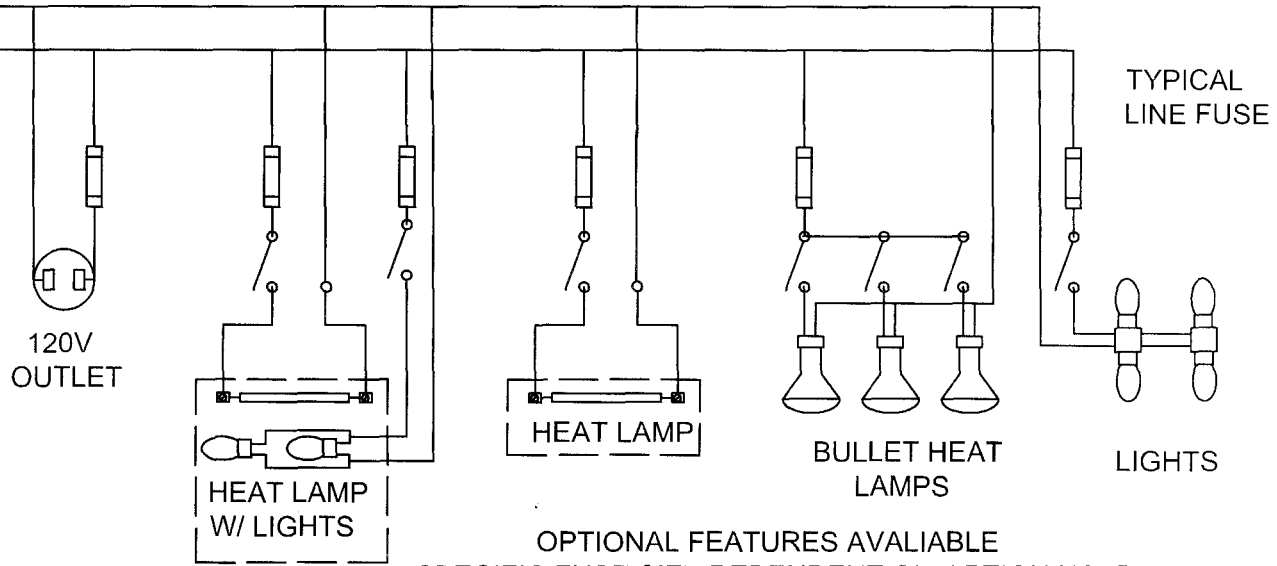

OPTIONAL FEATURES AVAILABLE
 SPECIFIC FUSE SIZE DEPENDENT ON OPTION USED
 ALL FUSES MUST BE CLASS "G" TYPE DUAL ELEMENT
 RATED FOR BRANCH CIRCUIT PROTECTION

REPLACEMENT PARTS LIST

ITEM NO.	DESCRIPTION	STOCK NO.
1.	THERMOSTAT	190700
2.	PILOT SAFETY VALVE	284200
3.	THERMOCOUPLE	284600
4.	FILTER	284900
5.	BURNER (NATURAL)	285200
6.	BURNER (L.P.)	285100
7.	UNIVERSAL PILOT KIT	284300
8.	3/8 GAS VALVE	283620
9.	PRESS. REG. (NATURAL)	284410
10.	PRESS. REG. (L.P.)	284420

***** PART NUMBER FOR 5000 BTU BURNER IS 285010 AND
SPECIFY NATURAL OR L.P.*****

ONE YEAR WARRANTY

ALL LOW TEMP FOOD SERVICE EQUIPMENT IS FULLY WARRANTED BY THE MANUFACTURER AGAINST DEFECTS IN MATERIALS OR WORKMANSHIP FOR A PERIOD OF ONE (1) YEAR FROM THE DATE OF PURCHASE BY THE ORIGINAL USER AND ONLY TO THE ORIGINAL PURCHASER PROVIDED IT IS INSTALLED AND OPERATED IN ACCORDANCE WITH THE INSTRUCTIONS SUPPLIED WITH THE UNIT. ALSO, IT MUST NOT BE MISUSED, ALTERED OR NEGLECTED AND USED ONLY ON CIRCUITS AND VOLTAGES REQUIRED FOR THAT UNIT.

OUR OBLIGATION UNDER THIS WARRANTY SHALL BE LIMITED TO ONE OF THE FOLLOWING PROCEDURES. SELECTION OF A PROCEDURE SHALL BE AT THE SOLE DISCRETION OF LOW TEMP INDUSTRIES INC.

LOW TEMP INDUSTRIES, INC. WARRANTY SERVICE DEPARTMENT MUST BE NOTIFIED PRIOR TO ANY SERVICE WORK OR COMPRESSOR REPLACEMENT FOR A WARRANTY AUTHORIZATION NUMBER. ANY REQUESTS FOR WARRANTY CLAIMS WITHOUT A WARRANTY AUTHORIZATION NUMBER, WILL NOT BE HONORED.

- A. REPLACEMENT OF DEFECTIVE PARTS, SHIPPED F.O.B. FACTORY, IN EXCHANGE FOR THE RETURNED DEFECTIVE PART, SHIPPED PREPAID FREIGHT.
- B. FREE REPLACEMENT OF DEFECTIVE PART, SHIPPED F.O.B. FACTORY.
- C. DEFECTIVE PART SHIPPED PREPAID FREIGHT TO FACTORY, REPAIRED AND RETURNED, SHIPPED F.O.B. . FACTORY.
- D. ALL LABOR COSTS SHALL BE COVERED FOR A PERIOD OF 1 YEAR FROM THE DATE OF PURCHASE.

LOW TEMP INDUSTRIES INC. SHALL NOT BE RESPONSIBLE FOR ANY DAMAGE CAUSED BY FIRE, FLOOD, WINDSTORM, OR ANY OTHER ACT OF GOD; WAR, WHETHER DECLARED OR UNDECLARED NOR SHALL WE BE RESPONSIBLE FOR THE LOSS OF FOOD OR OTHER PRODUCTS DUE TO POWER OR MECHANICAL FAILURE. THIS WARRANTY SHALL NOT COVER ANY DAMAGE CAUSED DURING SHIPMENT WHICH SHOULD BE REPORTED TO THE DELIVERING CARRIER.

LOW TEMP INDUSTRIES INC.
9192 TARA BOULEVARD
JONESBORO, GEORGIA 30236
(770) 478-8803