

**OPERATIONS AND MAINTENANCE MANUAL
REPLACEMENT PARTS LIST
FOR:**

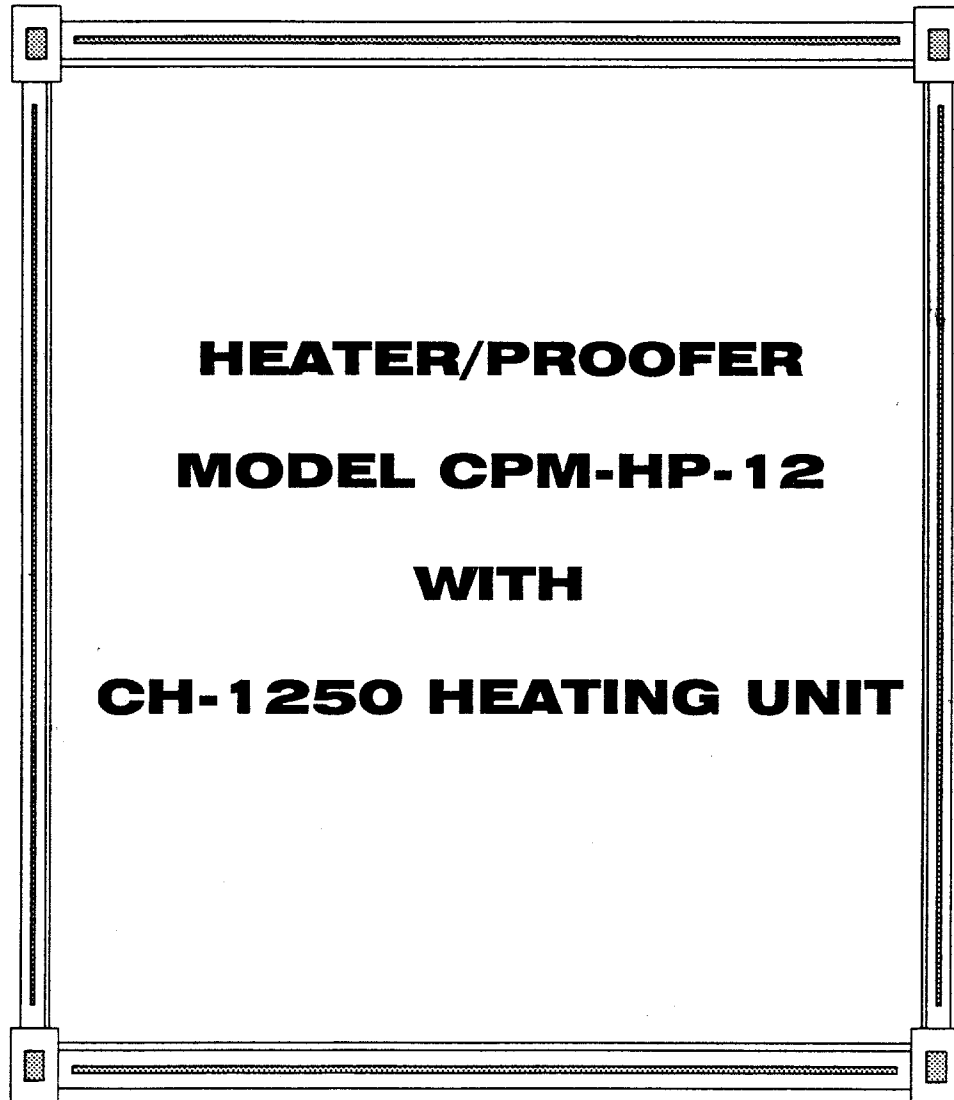

INSPECTION

UPON RECEIPT, THE CRATE SHOULD BE INSPECTED FOR VISUAL DAMAGE. ANY DAMAGE SHOULD BE REPORTED IMMEDIATELY TO THE CARRIER.

ELECTRICAL REQUIREMENTS

THIS UNIT IS A SELF CONTAINED, HEATER/PROOFER ASSEMBLY. IT IS DESIGNED TO BE OPERATED AT 120 VAC / 60 HZ AND IS RATED 1500 MAXIMUM 1500 WATTS. THIS UNIT IS PROVIDED WITH A REMOVABLE 8 FOOT 14-3 NEMA 5-15 CORD SET.

***** WARNING *****

IN ORDER TO PREVENT ANY ELECTRICAL ACCIDENTS, THIS EQUIPMENT SHOULD BE INSTALLED AND SERVICED BY QUALIFIED MAINTENANCE PERSONNEL ONLY PER NATIONAL ELECTRICAL CODE STANDARDS.

INSTALLATION INSTRUCTIONS

REMOVE UNIT FROM PACKAGING MATERIAL, TAKE CARE NOT TO SCRATCH THE FIBERGLASS WHEN UNPACKING. FEED THE SUPPLY CORD THROUGH THE ACCESS HOLE LOCATED IN THE REAR OF THE UNIT AND PLUG INTO AN APPROPRIATE POWER SUPPLY.

OPERATING INSTRUCTIONS

***** WARNING *****

NEVER POUR COLD WATER INTO A HOT FOOD PAN RECEPTACLE. IF THE WATER BOILS OUT, REFILL WITH HOT WATER OR WAIT UNTIL WELL HAS COOLED DOWN. IF COLD WATER IS Poured ON A HOT, EMPTY RECEPTACLE IT WILL CAUSE THE WELL TO SPLIT OR CRACK.

HEATING WET:

FILL THE PAN WITH APPROXIMATELY 2 INCHES OF WATER. PLACE THE LIGHTER ROCKER SWITCH TO THE "HEAT" POSITION. THE "RED" INDICATOR LIGHT SHOULD BE ON. TURN THE THERMOSTAT TO THE HIGHEST POSITION ON THE DIAL. THE RED PILOT LIGHT IS INDICATED WHEN THE HEATING ELEMENT IS ON. THIS LIGHT WILL GO OFF WHEN THE THERMOSTAT CYCLES.

PREHEAT THE CABINET FOR APPROXIMATELY 30 MINUTES BEFORE ADDING FOOD. ADJUST THE THERMOSTAT TO THE DESIRED TEMPERATURE (THIS IS BEST DETERMINED BY THE CUSTOMER). THE THERMOSTAT WILL REGULATE THE TEMPERATURE OF THE CABINET. THE SYSTEM IS PROVIDED WITH A DIAL THERMOMETER LOCATED IN THE DOOR OF THE UNIT.

HEATING DRY:

IF DRY HEATING IS DESIRED FOLLOW THE INSTRUCTIONS ABOVE, BUT DO NOT ADD WATER TO THE PAN.

PROOFING:

FILL THE PAN WITH APPROXIMATELY 2 INCHES OF WATER AND PLACE THE LIGHTER ROCKER SWITCH TO THE "PROOF" POSITION. THE "AMBER" INDICATOR LIGHT SHOULD BE ON. THE TEMPERATURE IS CONTROLLED BY AN INTERNAL THERMOSTAT THAT IS PRESET AT THE FACTORY.

ADJUSTABLE THERMOSTAT:

THE THERMOSTAT BULB IS CLAMPED TO THE OUTSIDE OF THE DEFLECTOR PLATE ON THE BOTTOM OF THE RECEPTACLE. A CAPILLARY TUBE EXTENDS FROM THE BULB TO THE THERMOSTAT CONTROL. WHENEVER THE HEATING UNIT IS ENERGIZED THE PILOT LIGHT GLOWS AND GOES OFF WHEN THE PRESET TEMPERATURE IS REACHED. THE CYCLING OF THE THERMOSTAT IS THEREFORE INDICATED BY THE PILOT LIGHT.

SHUTDOWN:

AT THE END OF THE DAY OR SERVING PERIOD, PLACE THE LIGHTED ROCKER SWITCH TO THE CENTER "OFF" POSITION. ALL INDICATOR LIGHTS SHOULD BE OFF. FOR ADDITIONAL SAFETY, UNPLUG THE UNIT FROM THE WALL RECEPTACLE.

CLEANING

CABINET:

DISCONNECT THE POWER SUPPLY CORD FROM THE REAR ELECTRICAL OUTLET.

CLEAN THE INSIDE OF THE CABINET WITH MILD DETERGENT AND A DAMP CLOTH. DO NOT USE SOAKED RAGS OR POUR WATER ON THE HEATING UNIT.

TO REMOVE THE HEATING UNIT DISCONNECT THE POWER CORD FROM THE REAR OF THE UNIT. REMOVE THE TWO (2) 8-32 SCREWS LOCATED ON THE SIDES OF THE HEATING UNIT. SLIDE THE HEATING UNIT OUT THE FRONT OF THE CABINET.

WITH THE HEATING UNIT REMOVED THE UNIT CAN BE WASHED DOWN WITH NO CONCERN FOR DAMAGING THE ELECTRICAL COMPONENTS. SEE THE FOLLOWING SECTION ON "HOW TO CLEAN STAINLESS STEEL" FOR MORE INFORMATION.

***** WARNING *****

DO NOT USE HARSH CHEMICALS, ACIDS OR ALKALIS IN CLEANING THIS TABLE OR HEATING RECEPTACLES. WITH ANY CLEANERS, READ INSTRUCTIONS CAREFULLY AND DILUTE AS INSTRUCTED BEFORE APPLYING TO STAINLESS STEEL EQUIPMENT.

THE FOOD WARMING RECEPTACLE IS MADE OF STAINLESS STEEL, BUT USE CARE DURING THE CLEANING OPERATION. HEAVY OBJECTS SHOULD NOT BE DROPPED IN THE RECEPTACLE.

CONTROL KNOB:

TO CLEAN THE THERMOSTAT KNOB, PULL THE KNOB OUTWARD TO REMOVE IT FROM THE SHAFT. WASH THE KNOB WITH MILD SOAP AND WATER, RINSE AND DRY WITH A SOFT CLOTH. DO NOT USE ABRASIVE CLEANERS ON THE PLASTIC SURFACES OF THE KNOB.

FIBERGLASS BODY PANELS:

THE FIBERGLASS BODY PANELS SHOULD BE CLEANED WITH A MILD NON-ABRASIVE CLEANER AND A SOFT CLOTH.

***** CAUTION *****

DO NOT USE BLEACHES, ABRASIVE CLEANERS OR ABRASIVE CLOTHS OR PADS AS THEY MAY DISCOLOR AND SCRATCH THE FIBERGLASS. DO NOT USE HARSH CHEMICALS, ACIDS OR ALKALIS IN THE CLEANING OF THE FIBERGLASS.

HOW TO CLEAN STAINLESS STEEL

THE FOLLOWING INFORMATION WAS TAKEN FROM A PAMPHLET BY MR. RICHARD E. PARET, STAINLESS STEEL SPECIALIST, AMERICAN IRON AND STEEL INSTITUTE.

STAINLESS STEEL IS ONE OF THE EASIEST MATERIALS TO CLEAN AND KEEP CLEAN.

THE REASONS FOR STAINLESS STEEL'S EASE OF CLEANING ARE EASY TO SEE; THEY LIE IN THE NATURE OF THE METAL ITSELF.

1. IT'S HARD, TOUGH SURFACE. STAINLESS STEEL WILL WORK HARDEN, THAT IS, THE MORE IT IS USED, THE MORE RESISTANT TO WEAR IT BECOMES. STAINLESS STEEL WILL NOT DEVELOP ROUGH SPOTS THAT HARBOR BACTERIA AND SOIL.

2. HIGH CORROSIVE RESISTANCE. STAINLESS STEEL IS PRACTICALLY UNTOUCHED BY THE CORROSIVE ATTACKS OF MOISTURE, DETERGENTS, FOOD ACIDS, BLOOD SALTS AND OTHER CORRODENTS CONNECTED WITH FOOD PREPARATION. THIS MEANS THAT STAINLESS STEEL ALWAYS HAS A BRIGHT SURFACE FREE FROM OXIDES THAT CAN AFFECT THE FLAVOR OF FOODS.

THE SECRET OF MAINTAINING STAINLESS STEEL IS FREQUENT, SCHEDULED CLEANING THAT WILL PREVENT BUILD UP OF SURFACE DEPOSITS. SURFACE DEPOSITS, IF ALLOWED TO REMAIN FOR LONG PERIODS OF TIME CAN HAM STAINLESS STEEL. STAINLESS STEEL THRIVES ON EXPOSURE TO AIR; UNDER CERTAIN CONDITIONS, THE LENGTHY DEPRIVATION OF OXYGEN BY HEAVY SOIL DEPOSITS CAN CAUSE LOCALIZED PITTING OR STAINING.

NEGLECTING THE MATERIAL IN THIS MANNER IS **DEFINITE ABUSE** WHICH EVEN STAINLESS STEEL IS NOT IMMUNE.

TWO BASIC RULES:

1. CLEAN FREQUENTLY, AND ON A FIXED SCHEDULE.
2. SELECT THE SIMPLEST METHOD.

TO REMOVE ORDINARY DIRT AND FOOD RESIDUE FROM STAINLESS STEEL EQUIPMENT THAT OPERATES AT LOW TEMPERATURES, USE ORDINARY SOAP AND WATER AND APPLY WITH A SPONGE, FIBER BRUSH OR CLOTH. TO HASTEN ACTION, ADD EITHER SODA ASH, BAKING SODA, BORAX OR ANY OF SEVERAL NON-ABRASIVE COMMERCIAL CLEANSING AGENTS.

TO REMOVE SPLATTER OR CONDENSED VAPOR WHICH HAVE "BAKED" ONTO THE EQUIPMENT, THE TREATMENT OUTLINED ABOVE IS OFTEN SUFFICIENT. IN OTHER CASES A GENTLE TO VIGOROUS POLISHING ACTION MAY BE NECESSARY.

FIRST TRY A PASTE MADE WITH WATER AND AMMONIA AS THE LIQUID AND EITHER MAGNESIUM OXIDE, FINELY POWDER PUMICE OR FRENCH CHALK AS THE SOLID. YOU CAN ALSO USE ONE OF SEVERAL COMMERCIAL CLEANERS LISTED IN THE FOLLOWING TABLE.

RUB AS GENTLY AS POSSIBLE IN THE DIRECTION OF THE POLISHING MARKS ON THE STEEL, USING A SOFT CLOTH. FOR MORE RESISTANT DEPOSITS, USE A STAINLESS STEEL SCOURING SPONGE OR STAINLESS STEEL WOOL OF THE FINEST POSSIBLE TEXTURE.

WHAT NOT TO DO:

DO NOT USE COMMON STEEL WOOL, SCOURING PADS, SCRAPERS, WIRE BRUSHES, FILES OR OTHER STEEL TOOLS, SINCE THESE CAN MAR THE STAINLESS STEEL. THESE PARTICLES WILL EVENTUALLY RUST AND STAIN THE SURFACE, AND YOU MAY HAVE TO REFINISH IT.

HOW TO CLEAN STAINLESS STEEL
(CONT.)

SLIGHTLY DARKENED AREAS SOMETIMES APPEAR ON STAINLESS STEEL SURFACES WHERE HEAT HAS BEEN APPLIED DURING FABRICATION OR IN SERVICE.

THESE ARE CAUSED BY THICKENING OF THE PROTECTIVE SURFACE OF STAINLESS STEEL, AND ARE NOT HARMFUL. REMOVAL CALLS FOR ENERGETIC SCOURING, AGAIN USING A STAINLESS STEEL WOOL OR SCOURING PAD, COMBINED WITH A SCOURING POWDER OR ONE OF THE HEAT-TINT REMOVERS LISTED IN THE TABLE.

THREE RULES WILL PREVENT HEAT TINTING:

- 1) USE ONLY ENOUGH HEAT TO DO THE JOB EFFICIENTLY.
- 2) DO NOT APPLY HEAT TO EMPTY EQUIPMENT.
- 3) AVOID CONCENTRATING HEAT ON A SMALL AREA.

***** CAUTION IS ADVISED *****

IN STERILIZING STAINLESS STEEL EQUIPMENT, PAY PARTICULAR ATTENTION TO AGENTS CONTAINING CHLORINE COMPOUNDS SUCH AS POTASSIUM HYPOCHLORITE. THESE COMPOUNDS MAY BREAK DOWN AND RELEASE FREE CHLORINE, OR HYDROLYZE TO FORM HYDROCHLORIC ACID.

STAINLESS STEEL RESISTS ATTACK BY SUCH COMPOUNDS FOR UP TO TWO HOURS. SEVERE LOCALIZED PITTING MAY OCCUR FROM LONGER EXPOSURE. FOR SAFE USE OF THESE AGENTS, KEEP CONTACT TIME SHORT, FLUSH THOROUGHLY WITH WATER, AND OPERATE EQUIPMENT NORMALLY BETWEEN APPLICATIONS. USING THESE PRECAUTIONS, THE STERILIZATION PROCESS CAN BE REPEATED ANY NUMBER OF TIMES.

CLEANERS AND THEIR EFFECT ON STAINLESS STEEL

Cleaning agent	Method of Application	Effect on Finish
1. Tightly adhering deposits of "baked on" spatter, oil, grease, weather stain, dyes or other light discoloration may be removed with any of the following cleaners.		
Grade FFF Italian pumice whiting or bon ami pressure on no.7	scour or rub with damp cloth	satisfactory for all finishes use light
Liquid NuSteel	scour with small amount on dry cloth	satisfactory for all finishes if rubbing pressure is light
Paste NuSteel or Temp	scour with small amount on dry cloth	satisfactory for no. 4 finish. Will scratch no.7
House hold cleaners such as Old Dutch, Sunbrite, Wyandotte, Bob-O, Gold Dust and Sapolio	Rub with damp cloth	Will scratch no. 4 finish slightly
Grade F Italian Pumice	Rub with damp cloth	Will scratch no.4 finish slightly
Cooper's stainless steel polish for no.4	satisfactory	Rub with damp cloth finish
Allen stainless steel polish considerably	Rub with damp cloth	Scratches but leaves mirror reflection
Best effect chemical co. cleaner & Passivator	Rub with damp cloth	May scratch no.4 finish slightly
2. Heat tint or heavy discoloration with the following (see notes below)		
Allen stainless polish	Small amount on damp cloth	Excellent heat tint remover
Birdsall's "Staybright" not	Rub with damp cloth	Very good for heat tint removable. Does scratch no.4 finish but does scratch no.7
Wyandotte or Bob-O removal	Rub with damp cloth	Good for heat tint
Oxalic acid (use warm) or 5-15% nitric acid	Swab or immerse. Always follow with a 5% sodium carbonate or neutralizer rinse	Good discoloration remover
Best effect chemical co. cleaner & Passivator surface	Rub with damp cloth	May scratch no 4 finish but leaves clean

CLEANERS AND THEIR EFFECT ON
STAINLESS STEEL
(Cont.)

Cleaning agent	Method of Application	Effect on Finish
<p>3. The following detergents and solvents are excellent removers of grease, oil and fatty acids, where swabbing or rubbing is not practical.</p>		
<p>4 to 6% solution of (sodium Metasilicate) (Trisodium Phosphate) (Sodium Metaphosphate) (Sodium Pyrophosphate)</p>		<p>All excellent removers of grease, oil, and milkstone</p>
<p>5-15% caustic soda (hot or cold)</p>		<p>Will remove grease and milkstone</p>
<p>4. The following organic solvents may be used for removing oils and grease deposits:</p>		
<p>Carbon-tetrachloride, Naphtha, Trichlorethylene Acetone, Kerosene, Gasoline, Ether, Alcohol, Benzene</p>		<p>No affect on finish, however, take all precautions against fire.</p>

Notes: ordinary wool or steel brushes should never be used on stainless steel surfaces. Particles of steel may become imbedded in the stainless steel surface, and rusting of these particles will eventually appear as stains. Use stainless steel wool or sponge on stainless steel equipment. Heat tint removers will usually scratch stainless steel surfaces. This, however, is necessary in removing heat tint by hand. Oakite, a fibrous material, may be used in place of metal sponges or cloth pads for applying cleaners and polishes. This material is effective in aiding in removal of milkstone.

For heavy hard water deposits, 15-20% (by volume) nitric acid is very effective. Acid treatment should be followed by a thorough water rinse.

The action of soldering fluxes should be neutralized immediately with a 5% sodium carbonate solution.

Soap and water followed by a water rinse will not harm stainless steel.

PREVENTATIVE MAINTENANCE OF COLORPOINT EQUIPMENT

To insure that your equipment will continue to operate properly, please follow these simple steps:

1. The food receptacle wells should be clean thoroughly every day. Food spillage left in the pans such as tomato paste can cause damage to the unit. The acidic base of foods over time can cause pitting of the units. For more cleaning information on these models, see the section on "HOW TO CLEAN STAINLESS STEEL" in this manual.
2. Always wipe the unit down with a damp cloth. Do not spray water directly in control panel areas or on areas with exposed heating elements.

COLORPOINT

8-95

BY LOW TEMP INDUSTRIES
JONESBORO, GEORGIA

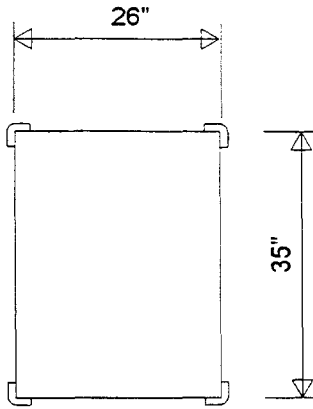

TOP VIEW

CPM-HP-12
HEATER/PROOFER CABINET

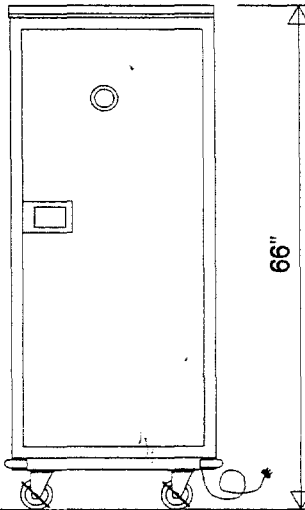

FRONT VIEW

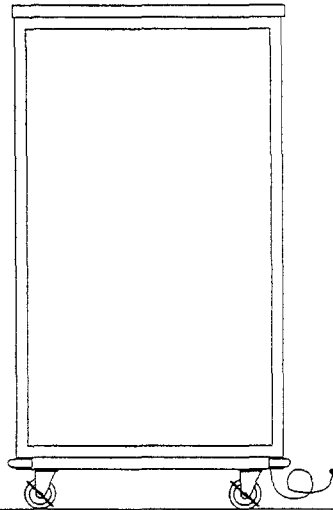

SIDE VIEW

MODEL	SIZE	120V-1PH PROOF/HEAT	NEMA PLUG TYPE	SHIPPING WT
CPM-HP-12	66"H X 26" W X 35" D	5.1 AMPS/13.5 AMPS	5-15P	325

TOP: TOP AND BOTTOM PLATFORM TO BE 18 GAUGE STAINLESS STEEL WITH SQUARE TURN DOWN ON ALL EXTERIOR SIDES AND CORNERS FULLY WELDED GROUND AND POLISHED. TO HAVE A #4 STAIN FINISH WITH ALL EXTERIOR EDGES HAVING A #7 HI-LITE FINISH.

BODY AND FRAME: FRAME TO BE 14 GAUGE STAINLESS STEEL CONSTRUCTION. FULL PERIMETER TOP AND BOTTOM FRAME FULLY WELDED, GROUND AND POLISHED TO VERTICAL CORNER UPRIGHTS MAKING BODY FRAME ONE INTEGRAL UNIT. NON MARKING CORNER BUMPERS SECURED TO BOTTOM FRAME

BODY AND DOOR PANELS: SEAMLESS MOLDED FIBERGLASS (F.R.P.) WITH SMOOTH EXTERIOR SURFACE AND ROUNDED CORNERS. ALL FIBERGLASS TO BE FLAME RETARDANT PER SPECIFICATIONS ASTM-E-162 HAVING A FLAME SPREAD OF 25 OR LESS.

CABINET INTERIOR: CABINET TO BE LINED WITH 20 GAUGE STAINLESS STEEL AND INSULATED WITH 1" HIGH DENSITY FIBERGLASS INSULATION. 14 GAUGE STAINLESS STEEL SLIDE RACKS ARE TO BE REMOVABLE WITH SIXTEEN (16) SETS OF PAN SLIDE ADJUSTMENT SLOTS PROVIDED ON 3" CENTERS. TWELVE (12) SETS OF UNIVERSAL PAN SLIDES SHALL BE PROVIDED WITH A PADDLE TYPE POSITIVE CLOSING DOOR LATCH.

HEATER UNIT: THE REMOVABLE HEATER UNIT IS PROVIDED WITH SEPERATE CONTROLS AND ELEMENTS FOR PROOFING OR HEATING AND INCORPORATES A WATER BASIN WITH BAFFLE FOR HUMIDITY CONTROL. TO BE PROVIDED WITH A DETACHABLE 8' POWER CORD

CASTERS: 4" DIAMETER BALL BEARING, SWIVEL TYPE, NON MARKING WITH BRAKES ON ALL WHEELS. CASTERS TO BE MOUNTED WITH INTERNAL AND EXTERNAL BRACING FOR MAXIMUM STRESS RELIEF.

APPROVALS: THIS UNIT IS LISTED BY UNDERWRITERS LABORATORIES FOR SAFETY AND CLASSIFIED BY UNDERWRITERS LABORATORIES FOR SANITATION UNDER NSF STANDARD NO. 4 AND SHALL BEAR BOTH SEALS.

TROUBLE SHOOTING

SERVICE TO BE PERFORMED BY QUALIFIED SERVICE TECHNICIAN ONLY.

UNIT DOES NOT HEAT UP IN THE PROOF MODE:

1. CHECK TO MAKE SURE THAT THERE IS PROPER POWER AT THE WALL RECEPTACLE (120VAC, 15 AMP).
BE SURE THAT THE MAIN ELECTRICAL PANEL IS TURNED ON.
2. MAKE SURE THAT THE SWITCH IS IN THE "PROOF" POSITION. THE AMBER LIGHT SHOULD BE ON.
3. IF THE AMBER LIGHT DOES NOT COME ON, TURN POWER OFF ON UNIT AND DISCONNECT THE POWER SUPPLY CORD FROM THE BACK OF THE UNIT.
 - 3A. REMOVE THE TWO SCREWS HOLDING THE CH-1250 HEATING UNIT IN THE CABINET.
 - 3B. LIFT THE CH-1250 HEATING UNIT OUT OF THE UNIT.
4. LAY THE HEATING UNIT ON ITS BACK AND REMOVE THE SCREWS HOLDING THE BOTTOM PLAT ON THE UNIT.
5. RECONNECT THE POWER SUPPLY TO THE UNIT. **USE EXTREME CAUTION, YOU ARE NOW EXPOSED TO LIVE ELECTRICAL PARTS.**
6. CHECK VOLTAGE ACROSS TERMINALS "L1" AND "N" WITH AN APPROPRIATE VOLTAGE TESTING METER. YOU SHOULD HAVE 120 VAC AT THESE TERMINALS. IF NOT REVIEW STEP 1.
7. CHECK VOLTAGE ACROSS THE CENTER TERMINALS OF THE LIGHTED ROCKER SWITCH. THERE SHOULD BE 120 VAC AT THESE TERMINALS. IF NOT, CHECK WIRING BACK TO TERMINAL BLOCK.
8. TURN THE SWITCH TO "PROOF" SETTING. CHECK VOLTAGE ACROSS THE TERMINAL ENDS WITH ONLY ONE WIRE ATTACHED. NOTE IT IS OPPOSITE THE DIRECTION THAT THE SWITCH IS PUSHED. IF NO VOLTAGE IS PRESENT AT THESE TERMINALS REPLACE THE SWITCH.
9. CHECK THE TERMINALS AT THE THERMOSTAT LOCATED ON THE ALUMINUM PLATE. CHECK FROM ONE SIDE BACK TO THE NEUTRAL ON THE TERMINAL BLOCK. IF VOLTAGE IS NOT PRESENT BETWEEN BOTH TERMINALS AND THE NEUTRAL, REPLACE THE THERMOSTAT.
10. IF ALL OF THE ABOVE CHECKS OUT, DISCONNECT THE POWER FROM THE UNIT. REMOVE THE WIRING FROM HEATER ELEMENT TERMINALS AND CHECK THE CONTINUITY THROUGH THE HEATING ELEMENT. THE RESISTANCE FOR THE 500W/120V ELEMENT IS APPROXIMATELY 29 OHMS.
11. IF THE HEATING ELEMENT SHOWS NO CONTINUITY OR A RESISTANCE LEVEL OUT OF SPEC. REPLACE THE ELEMENT.

UNIT DOSE NOT HEAT-UP IN HEAT MODE:

1. FOLLOW STEPS 1 THRU 7 LISTED ABOVE
2. PLACE THE SWITCH TO THE "HEAT" SETTING. CHECK THE VOLTAGE ACROSS THE SWITCH ON THE END WITH WIRE ON BOTH TERMINALS. NOTE IT IS OPPOSITE THE DIRECTION THAT THE SWITCH IS PUSHED. IF NO VOLTAGE IS PRESENT REPLACE THE SWITCH.

UNIT DOES NOT HEAT-UP IN HEAT MODE: CONTINUED

3. TURN THE THERMOSTAT LOCATED BESIDE THE SWITCH TO THE MAXIMUM SETTING. CHECK THE VOLTAGE ACROSS BOTH SIDES OF THE TERMINALS. IF NO VOLTAGE IS PRESENT ON THE SIDE GOING TO THE HEATING ELEMENT REPLACE THE THERMOSTAT.
4. REMOVE ALL POWER FROM THE UNIT. DISCONNECT THE WIRING AT THE HEATING ELEMENT LOCATED IN THE BACK VERTICAL CAVITY AND CHECK FOR CONTINUITY IN THE HEATING ELEMENT. THE RESISTANCE FOR THE 1000W/120V IS APPROXIMATELY 14 OHMS.
5. IF THE HEATING ELEMENT SHOWS NO CONTINUITY OR A RESISTANCE LEVEL OUT OF SPEC. REPLACE THE ELEMENT.

UNIT DOES NOT HEAT-UP TO PROPER TEMPERATURE IN THE HEAT MODE:

THE THERMOSTAT LOCATED BESIDE THE CONTROL SWITCH IS CALIBRATED AT THE FACTORY. IF FIELD ADJUSTMENT IS REQUIRED SEE THE CALIBRATION PROCEDURE PROVIDED IN THIS MANUAL.

REPLACEMENT PARTS LIST
MODEL CPM-HP-12

CH-1250 HEATING UNIT

ITEM NO.	DESCRIPTION	STOCK NO.	MFG. NO.	MANUFACTURER
1	MALE FLANGE INLET	339910	5278-C	HUBBELL
2	1000W/120V HEATING ELEMENT	194900	319871242006	CROMALOX
3	INSULATING BUSHING	359010	2126	HEYCO
4	BLOWER MOTOR	258112	4C012A	DAYTON
5	TERMINAL STRIP	513700	724	BUCHANAN
6	THERMOSTAT SURFACE MOUNT	195450	30000-48	FENWAL
7	500W/120V HEATING ELEMENT	194830	319371242018	CROMALOX
8	ALUMINUM PLATE	N/A	FABRICATED	LOW TEMP
9	HOLDING STRAP	N/A	FABRICATED	LOW TEMP
10	THERMOSTAT MOUNTED IN CONTROL PANEL	190810	KA-374-72	ROBERTSHAW
11	LIGHTER ROCKER SWITCH	335913	LT1GM721-6S BL-RC-AM-NBL	CARLING
12	SWITCH MOUNTING PLATE (NOTE! SWITCH PLATE MUST BE PUNCHED FOR THIS ITEM)	370210	53060	VOLRATH
13	CORD AND PLUG SET	251231	14/3 WITH MALE & FEMALE	MAYER
14	PILOT LIGHT	358000	515-5CL	JEMCO

LOW TEMP INDUSTRIES
 HEATER ASSEMBLY MODEL CH-1250 USED IN
 HEATER/PROOFER MODEL CPM-HP-12

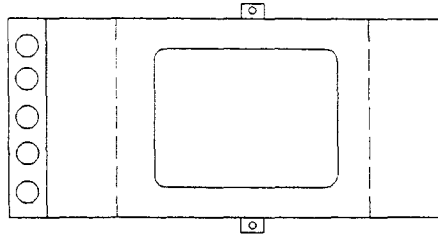

TOP

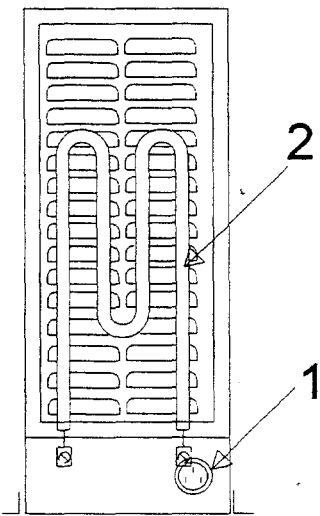

REAR

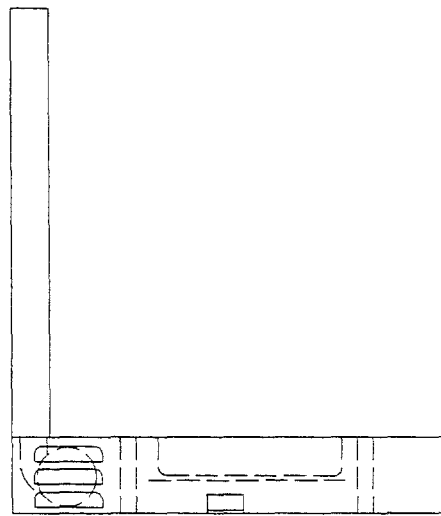

SIDE

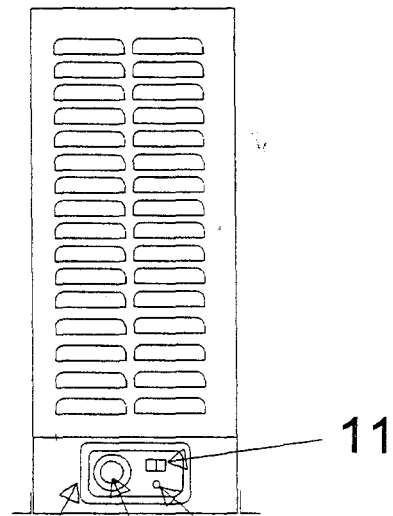

FRONT

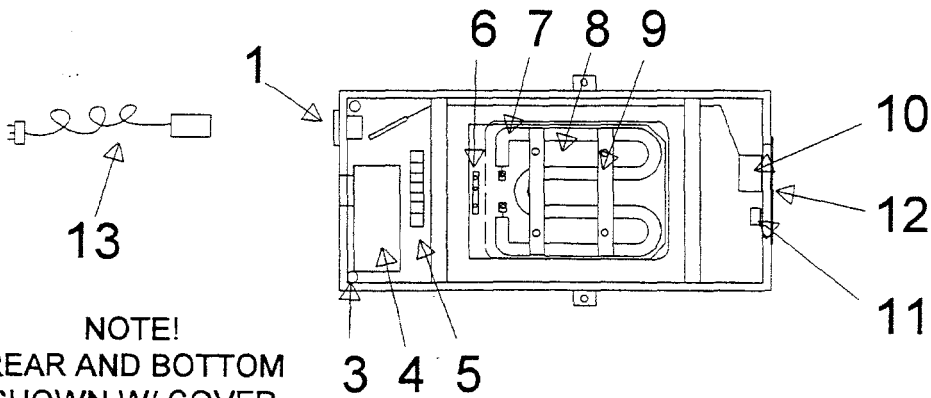

BOTTOM

NOTE!
 REAR AND BOTTOM
 SHOWN W/
 COVER
 REMOVED

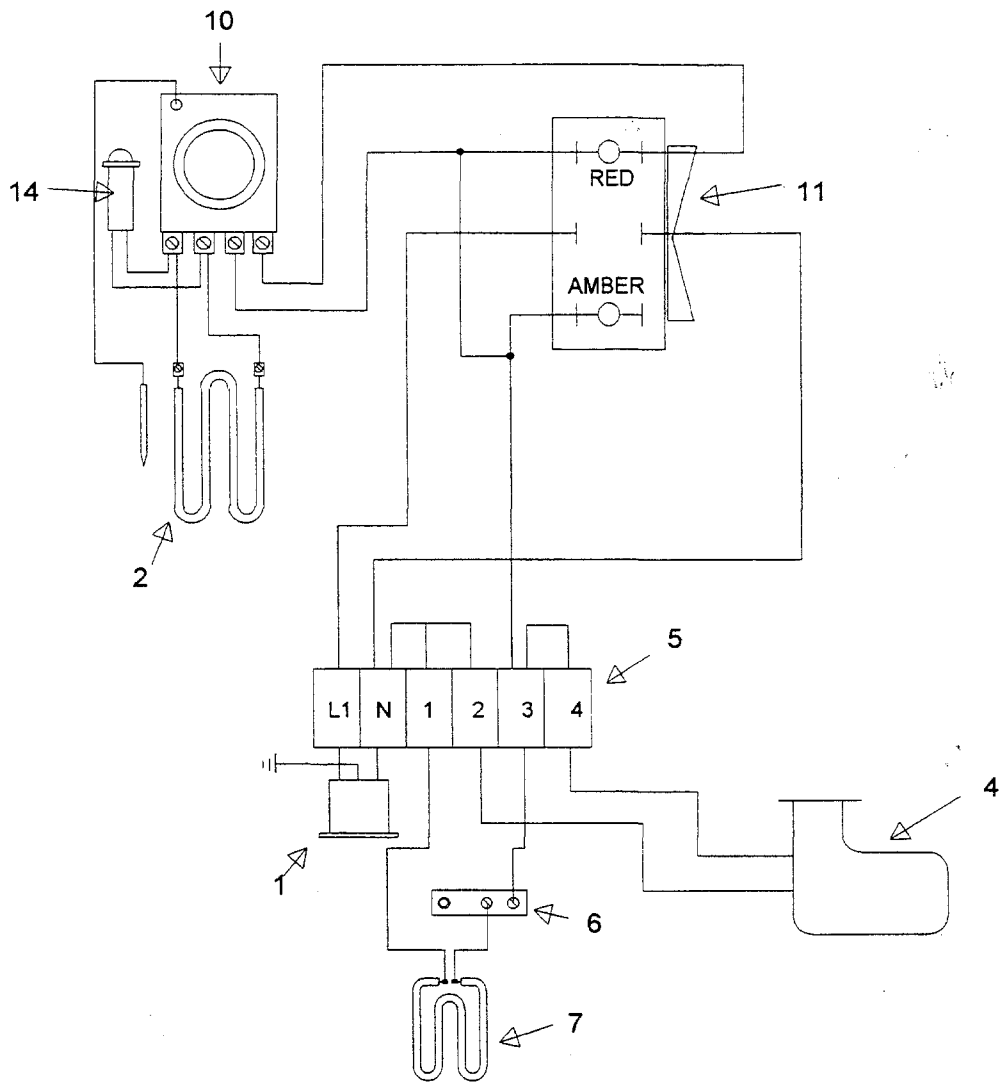

LOW TEMP INDUSTRIES INC.
 JONESBORO, GEORGIA

WIRING DIAGRAM
 NO. CH-1250

DATE: 8-24-95

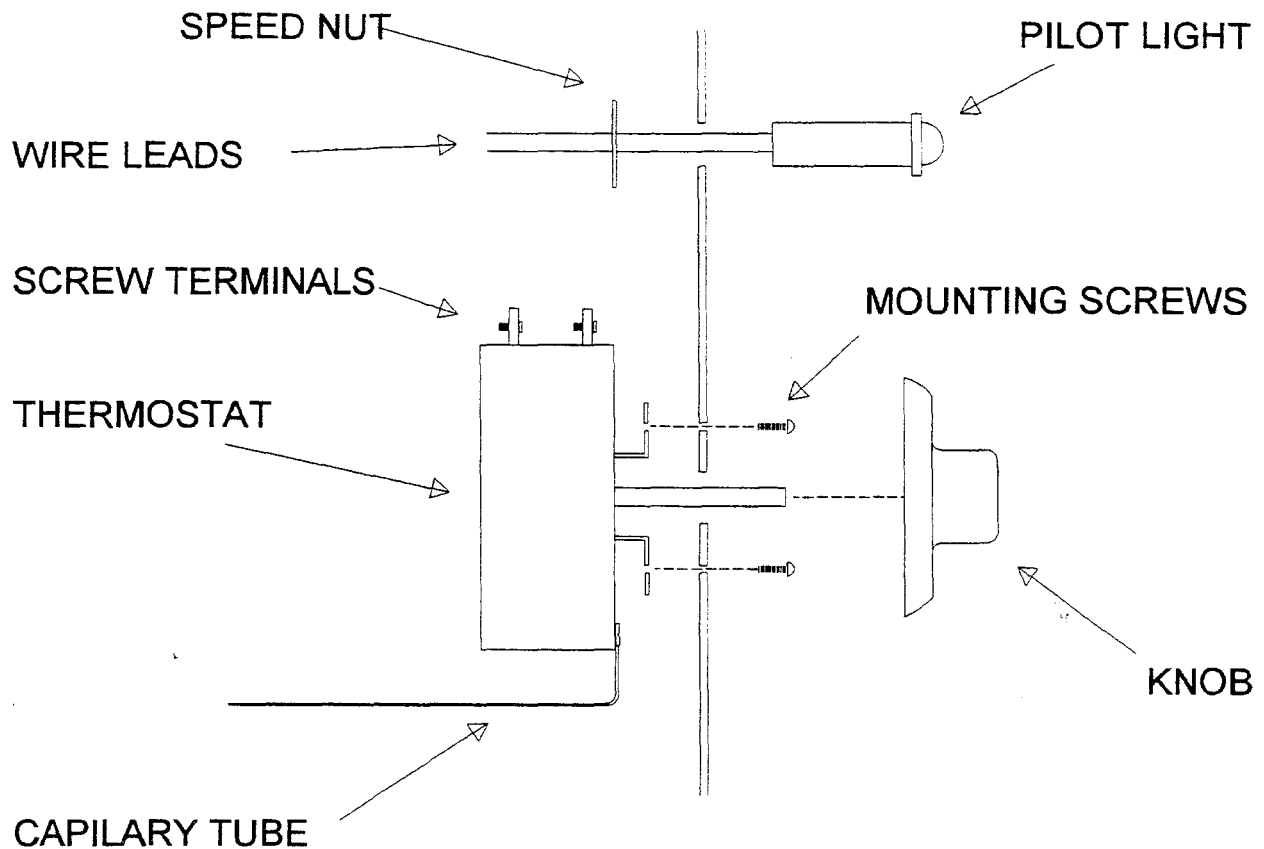

THERMOSTAT & PILOT LIGHT MOUNTING

TO REMOVE THERMOSTAT

1. DISCONNECT ELECTRICAL POWER
2. REMOVE THERMOSTAT MOUNTING PANEL BY REMOVING SCREWS AND PULLING PANEL FORWARD.
3. REMOVE WIRE LEADS FROM THERMOSTAT SCREW TERMINALS.
4. PULL KNOB OFF AND REMOVE THE TWO MOUNTING SCREWS ON THE FRONT OF THE THERMOSTAT.
5. REMOVE THE BOTTOM COVER PLATE FROM THE HOT FOOD WELL
6. REMOVE THE CAPILARY BULB FROM THE DEFLECTOR PLATE.

TO REPLACE THE THERMOSTAT REVERSE THE ABOVE PROCEDURE.

TO REMOVE PILOT LIGHT

1. DISCONNECT ELECTRICAL POWER
2. REMOVE THE THERMOSTAT MOUNTING PANEL BY REMOVING SCREWS AND PULLING PANEL FORWARD.
3. REMOVE THE WIRE LEADS FROM THERMOSTAT SCREW TERMINALS.
4. REMOVE THE SPEED NUT ON BACK OF PILOT LIGHT.
5. PULL PILOT LIGHT FORWARD.

TO REPLACE THE PILOT LIGHT REVERSE THE ABOVE PROCEDURE.

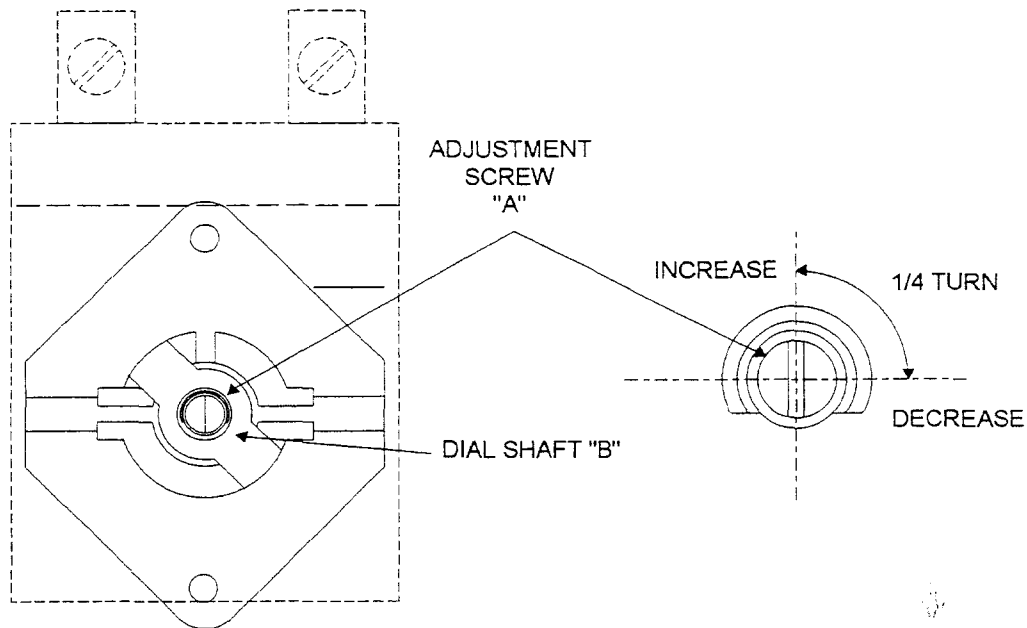

LOW TEMP INDUSTRIES CHECKING THERMOSTAT CALIBRATION

EACH THERMOSTAT IS ADJUSTED AT THE FACTORY AND CALIBRATED ON A PRECISION INSTRUMENT TO CONTROL TEMPERATURE ACCURATELY. ADJUSTMENT OR RECALIBRATION IS NOT NEEDED UNLESS THE THERMOSTAT HAS BEEN MISHANDLED IN TRANSIT OR CHANGED OR OTHERWISE ABUSED WHILE IN SERVICE.

TO CHECK CALIBRATION

1. USE A POTENTIOMETER OR A GOOD GRADE THERMOMETER TO DETERMINE TEMPERATURE AT LOCATION WHERE TEMPERATURE REGULATION IS REQUIRED.
2. TURN THE DIAL OF THE THERMOSTAT TO A MEDIUM TEMPERATURE SETTING.
3. ALLOW ENOUGH TIME FOR THE TEMPERATURE TO STABILIZE, OR UNTIL SEVERAL TEMPERATURE READINGS ARE IDENTICAL.

TO RECALIBRATE

1. REMOVE DIAL FROM SHAFT "B"
2. WHILE HOLDING SHAFT "B" TURN THE ADJUSTMENT SCREW "A" CLOCKWISE TO DECREASE OR COUNTERCLOCKWISE TO INCREASE. IT IS RECOMMENDED THAT ADJUSTMENTS BE NO MORE THAN 1/4 TURN AT A TIME.
3. REPLACE DIAL
4. AFTER A CALIBRATION CHANGE HAS BEEN MADE LET THE UNIT OPERATE UNTIL THE TEMPERATURE HAS STABILIZED, THEN RECHECK TO DETERMINE WHETHER OR NOT THE CALIBRATION HAS BEEN CORRECTED.

WARRANTY

WE WARRANT TO THE ORIGINAL PURCHASER OF OUR PRODUCT, THAT ALL EQUIPMENT MANUFACTURED BY US IS FREE FROM DEFECTS IN MATERIAL OR WORKMANSHIP UNDER NORMAL USE AND SERVICE. OUR OBLIGATION UNDER THIS WARRANTY SHALL BE LIMITED TO REPAIRING OR REPLACING AT OUR OPTION, ANY PART OF SAID EQUIPMENT WHICH PROVES TO BE DEFECTIVE WITHIN A PERIOD OF ONE (1) YEAR FROM THE DATE OF THE ORIGINAL INSTALLATION AND WHICH ON OUR EXAMINATION SHALL DISCLOSE TO OUR SATISFACTION TO BE THUS DEFECTIVE. THIS WARRANTY IS IN LIEU OF ALL OTHER WARRANTIES EXPRESSED OR IMPLIED AND OF ALL OTHER OBLIGATIONS OR LIABILITIES ON THE PART OF THE CORPORATION. ALSO IT NEITHER ASSUMES NOR AUTHORIZES ANY OTHER PERSON TO ASSUME FOR IT ANY OTHER OBLIGATION OR LIABILITY IN CONNECTION WITH THE SALE OF SAID EQUIPMENT. THIS WARRANTY DOES NOT APPLY TO EQUIPMENT WHICH HAS BEEN SUBJECT TO ANY ACCIDENT, ALTERATION, ABUSE OR MISUSE. FURTHERMORE, THE WARRANTY DOES NOT COVER EQUIPMENT THAT HAS BEEN DAMAGED AS A RESULT OF FIRE, FLOOD, WIND STORM OR ANY OTHER ACT OF GOD, WAR WHETHER DECLARED OR UNDECLARED NOR SHALL WE BE RESPONSIBLE FOR THE LOSS OF FOOD OR OTHER PRODUCTS DUE TO LOSS OF POWER OR MECHANICAL FAILURE.

COLORPOINT FIBERGLASS FOOD SERVICE EQUIPMENT

**A DIVISION OF LOW TEMP INDUSTRIES INC.
9192 TARA BOULEVARD
JONESBORO, GEORGIA 30236
(770) 478-8803**