

OPERATION AND MAINTENANCE MANUAL REPLACEMENT PARTS LIST FOR

**BT SERIES
BEVERAGE TABLES**

**ST SERIES
SOLID TOP TABLES**

**CSE & CSS SERIES
CASHIER STANDS**

**WT SERIES
WORK TABLES**

**CFI SERIES
ICE COOLED COLD PANS**

**RTE & RTS SERIES
TRAY STANDS**

INTRODUCTION

THIS MANUAL HAS BEEN COMBINED TO INCLUDE A NUMBER OF DIFFERENT MODELS. ALL OF THESE MODELS ARE CLASSIFIED AS PORTABLE WORK COUNTERS AND MOST CAN BE PURCHASED WITH A NUMBER OF DIFFERENT ELECTRICAL OPTIONS. WHEN REFERENCING THE ELECTRICAL DIAGRAM INCLUDED, PLEASE CHECK YOUR SPECIFIC UNIT FOR THOSE OPTIONS WHICH WERE INCLUDED. DISREGARD THOSE OPTIONS THAT ARE NOT APPLICABLE TO YOUR SPECIFIC UNIT. THE FUSING OF CIRCUITS MAY VARY FROM THE DIAGRAM DEPENDING UPON THE NUMBER OF ELECTRICAL DEVICES PROVIDED AND THE SIZE OF THE ELECTRICAL SERVICE REQUIRED.

INSPECTION

UPON RECEIPT, THE CRATE SHOULD BE INSPECTED FOR VISUAL DAMAGE. ANY DAMAGE SHOULD BE REPORTED IMMEDIATELY TO THE CARRIER.

INSTALLATION INSTRUCTIONS

THE COLOR POINT SERIES OF FOOD SERVICE EQUIPMENT IS DESIGNED FOR FOOD PREPARATION, HOLDING OR TRAY LINE SUPPORT. THE DESIGN OF THIS UNIT ALLOWS FOR A MODULAR OPERATION, WHERE A GROUP OF UNITS CAN BE ARRANGED TO FORM A CAFETERIA SERVING LINE. ROLL THE TABLE INTO A SERVING LINE OR OTHER NEEDED POSITION AND LOCK THE BRAKES ON THE CASTERS. IF ELECTRICAL OPTIONS ARE PROVIDED, THE UNITS COME COMPLETELY PRE-WIRED WITH A CORD AND PLUG, READY FOR CONNECTION TO THE PROPER POWER SUPPLY.

IF LINE UP LOCKS ARE PROVIDED, SIMPLY ALIGN THE UNITS AND PUSH THE BARREL BOLTS THROUGH THE KEY HOLE SLOTS ON BOTH UNITS THEN TURN THE BOLT DOWN AND PUSH UP THE CAM LOCKING LEVER. TO UNLOCK THE UNITS, REVERSE THIS PROCEDURE.

OPERATING INSTRUCTIONS

THE COLOR POINT SERIES IS DESIGNED FOR MODULAR OPERATION. THESE UNITS ARE DESIGNED TO BE ALIGNED END TO END AND LOCKED TOGETHER TO FORM A CONTINUOUS SERVING LINE, OR MAY BE USED FREE STANDING.

THE ELECTRICAL OPTIONS SUCH AS LIGHTS AND HEAT LAMPS ARE PROVIDED WITH INDIVIDUAL SWITCHES. THE ELECTRICAL CIRCUITS ARE PROVIDED WITH FUSES IF THE SYSTEM USES A COMBINATION OF SEVERAL ELECTRICAL DEVICES. IF THE ONLY ELECTRICAL DEVICE ON THE UNIT IS A SINGLE ELECTRICAL OUTLET THE UNIT WILL NOT BE FUSED.

CLEANING

THE TOP AND INTERIOR SURFACES OF THIS EQUIPMENT IS MANUFACTURED FROM STAINLESS STEEL. PLEASE REFER TO THE FOLLOWING SECTION CALLED "HOW TO CLEAN STAINLESS STEEL" FOR CLEANING INSTRUCTIONS.

THE EXTERIOR BODY IS MANUFACTURED FROM FIBERGLASS. SEE THE FOLLOWING SECTION TITLED "FIBERGLASS BODY" FOR CLEANING INSTRUCTIONS.

THE BREATH PROTECTORS ARE MANUFACTURED FROM PLEXIGLASS. SEE THE FOLLOWING SECTION TITLED "PLEXIGLASS SHIELDS" FOR CLEANING INSTRUCTIONS.

FIBERGLASS BODY:

THE FIBERGLASS BODY SHOULD BE CLEANED WITH A MILD NON-ABRASIVE CLEANER AND A SOFT CLOTH.

***** CAUTION *****

DO NOT USE BLEACHES, ABRASIVE CLEANERS OR ABRASIVE CLOTHS OR PADS AS THEY MAY DISCOLOR AND SCRATCH THE FIBERGLASS. DO NOT USE HARSH CHEMICALS, ACIDS OR ALKALIS IN THE CLEANING OF THE FIBERGLASS.

PLEXIGLASS SHIELDS:

USE A MILD SOAP AND A SOFT CLOTH WHEN CLEANING THE PLEXIGLASS SURFACES. WIPING THE SURFACE WITH A DRY CLOTH CAN CAUSE SCRATCHES.

DO NOT USE WINDOW CLEANING SPRAY OR KITCHEN SCOURING COMPOUNDS. PRODUCTS WITH A HIGH **ALCOHOL** CONTENT CAN CAUSE SURFACE FISSURES COMMONLY REFERRED TO AS "**CRAZING**". THIS WILL OCCUR IN ANY SPOT THAT HAS BEEN SUBJECT TO STRESSES, SUCH AS CHIPPED OR BURNED SAW CUTS, CRACKED HOLES FLAME POLISHED EDGES, FORMED EDGES, ETC.

***** WARNING *****

IN ORDER TO PREVENT ANY ELECTRICAL ACCIDENTS, THIS EQUIPMENT SHOULD BE INSTALLED AND SERVICED BY QUALIFIED MAINTENANCE PERSONNEL ONLY PER NATIONAL ELECTRICAL CODE STANDARDS.

VARIOUS OPTIONS MAY BE PURCHASED WITH THIS EQUIPMENT. WHEN THESE OPTIONS ARE PROVIDED THE ELECTRICAL CIRCUITS MAY BE SEPARATELY FUSED WITH **CLASS "G" FUSES**. IF FUSES MUST BE REPLACED **REPLACE WITH THE SAME TYPE AND AMPERAGE FUSE.**

HOW TO CLEAN STAINLESS STEEL

THE FOLLOWING INFORMATION WAS TAKEN FROM A PAMPHLET BY MR. RICHARD E. PARET, STAINLESS STEEL SPECIALIST, AMERICAN IRON AND STEEL INSTITUTE.

STAINLESS STEEL IS ONE OF THE EASIEST MATERIALS TO CLEAN AND KEEP CLEAN.

THE REASONS FOR STAINLESS STEEL'S EASE OF CLEANING ARE EASY TO SEE; THEY LIE IN THE NATURE OF THE METAL ITSELF.

1. IT'S HARD, TOUGH SURFACE. STAINLESS STEEL WILL WORK HARDEN, THAT IS, THE MORE IT IS USED, THE MORE RESISTANT TO WEAR IT BECOMES. STAINLESS STEEL WILL NOT DEVELOP ROUGH SPOTS THAT HARBOR BACTERIA AND SOIL.
2. HIGH CORROSIVE RESISTANCE. STAINLESS STEEL IS PRACTICALLY UNTOUCHED BY THE CORROSIVE ATTACKS OF MOISTURE, DETERGENTS, FOOD ACIDS, BLOOD SALTS AND OTHER CORRODENTS CONNECTED WITH FOOD PREPARATION. THIS MEANS THAT STAINLESS STEEL ALWAYS HAS A BRIGHT SURFACE FREE FROM OXIDES THAT CAN AFFECT THE FLAVOR OF FOODS.

THE SECRET OF MAINTAINING STAINLESS STEEL IS FREQUENT, SCHEDULED CLEANING THAT WILL PREVENT BUILD UP OF SURFACE DEPOSITS. SURFACE DEPOSITS, IF ALLOWED TO REMAIN FOR LONG PERIODS OF TIME CAN HAM STAINLESS STEEL. STAINLESS STEEL THRIVES ON EXPOSURE TO AIR; UNDER CERTAIN CONDITIONS, THE LENGTHY DEPRIVATION OF OXYGEN BY HEAVY SOIL DEPOSITS CAN CAUSE LOCALIZED PITTING OR STAINING.

NEGLECTING THE MATERIAL IN THIS MANNER IS **DEFINITE ABUSE** WHICH EVEN STAINLESS STEEL IS NOT IMMUNE.

TWO BASIC RULES:

1. CLEAN FREQUENTLY, AND ON A FIXED SCHEDULE.
2. SELECT THE SIMPLEST METHOD.

TO REMOVE ORDINARY DIRT AND FOOD RESIDUE FROM STAINLESS STEEL EQUIPMENT THAT OPERATES AT LOW TEMPERATURES, USE ORDINARY SOAP AND WATER AND APPLY WITH A SPONGE, FIBER BRUSH OR CLOTH. TO HASTEN ACTION, ADD EITHER SODA ASH, BAKING SODA, BORAX OR ANY OF SEVERAL NON-ABRASIVE COMMERCIAL CLEANSING AGENTS.

TO REMOVE SPLATTER OR CONDENSED VAPOR WHICH HAVE "BAKED" ONTO THE EQUIPMENT, THE TREATMENT OUTLINED ABOVE IS OFTEN SUFFICIENT. IN OTHER CASES A GENTLE TO VIGOROUS POLISHING ACTION MAY BE NECESSARY.

FIRST TRY A PASTE MADE WITH WATER AND AMMONIA AS THE LIQUID AND EITHER MAGNESIUM OXIDE, FINELY POWDER PUMICE OR FRENCH CHALK AS THE SOLID. YOU CAN ALSO USE ONE OF SEVERAL COMMERCIAL CLEANERS LISTED IN THE FOLLOWING TABLE.

RUB AS GENTLY AS POSSIBLE IN THE DIRECTION OF THE POLISHING MARKS ON THE STEEL, USING A SOFT CLOTH. FOR MORE RESISTANT DEPOSITS, USE A STAINLESS STEEL SCOURING SPONGE OR STAINLESS STEEL WOOL OF THE FINEST POSSIBLE TEXTURE.

WHAT NOT TO DO:

DO NOT USE COMMON STEEL WOOL, SCOURING PADS, SCRAPERS, WIRE BRUSHES, FILES OR OTHER STEEL TOOLS, SINCE THESE CAN MAR THE STAINLESS STEEL. THESE PARTICLES WILL EVENTUALLY RUST AND STAIN THE SURFACE, AND YOU MAY HAVE TO REFINISH IT.

HOW TO CLEAN STAINLESS STEEL
(CONT.)

SLIGHTLY DARKENED AREAS SOMETIMES APPEAR ON STAINLESS STEEL SURFACES WHERE HEAT HAS BEEN APPLIED DURING FABRICATION OR IN SERVICE.

THESE ARE CAUSED BY THICKENING OF THE PROTECTIVE SURFACE OF STAINLESS STEEL, AND ARE NOT HARMFUL. REMOVAL CALLS FOR ENERGETIC SCOURING, AGAIN USING A STAINLESS STEEL WOOL OR SCOURING PAD, COMBINED WITH A SCOURING POWDER OR ONE OF THE HEAT-TINT REMOVERS LISTED IN THE TABLE.

THREE RULES WILL PREVENT HEAT TINTING:

- 1) USE ONLY ENOUGH HEAT TO DO THE JOB EFFICIENTLY.
- 2) DO NOT APPLY HEAT TO EMPTY EQUIPMENT.
- 3) AVOID CONCENTRATING HEAT ON A SMALL AREA.

***** CAUTION IS ADVISED *****

IN STERILIZING STAINLESS STEEL EQUIPMENT, PAY PARTICULAR ATTENTION TO AGENTS CONTAINING CHLORINE COMPOUNDS SUCH AS POTASSIUM HYPOCHLORITE. THESE COMPOUNDS MAY BREAK DOWN AND RELEASE FREE CHLORINE, OR HYDROLYZE TO FORM HYDROCHLORIC ACID.

STAINLESS STEEL RESISTS ATTACK BY SUCH COMPOUNDS FOR UP TO TWO HOURS. SEVERE LOCALIZED PITTING MAY OCCUR FROM LONGER EXPOSURE. FOR SAFE USE OF THESE AGENTS, KEEP CONTACT TIME SHORT, FLUSH THOROUGHLY WITH WATER, AND OPERATE EQUIPMENT NORMALLY BETWEEN APPLICATIONS. USING THESE PRECAUTIONS, THE STERILIZATION PROCESS CAN BE REPEATED ANY NUMBER OF TIMES.

CLEANERS AND THEIR EFFECT ON STAINLESS STEEL

| Cleaning agent | Method of Application | Effect on finish |
|--|--|--|
| 1. Tightly adhering deposits of "baked on" spatter, oil, grease, weather stain, dyes or other light discoloration may be removed with any of the following cleaners. | | |
| Grade FFF Italian pumice whitening or bon ami | scour or rub with damp cloth | satisfactory for all finishes use light pressure on no.7 |
| Liquid NuSteel | scour with small amount on dry cloth | satisfactory for all finishes if rubbing pressure is light |
| Paste NuSteel or Temp | scour with small amount on dry cloth | satisfactory for no. 4 finish. Will scratch no.7 |
| House hold cleaners such as Old Dutch, Sunbrite, Wyandotte, Bob-O, Gold Dust and Sapolio | Rub with damp cloth | Will scratch no. 4 finish slightly |
| Grade F Italian Pumice | Rub with damp cloth | Will scratch no. 4 finish slightly. |
| Cooper's stainless steel polish | Rub with damp cloth | satisfactory for no.4 finish |
| Allen stainless steel polish | Rub with damp cloth | Scratches considerably but leaves mirror reflection. |
| Best Effect Chemical Co. cleaner & Passivator | Rub with damp cloth | May scratch no.4 finish slightly |
| 2. Heat tint or heavy discoloration with the following (see notes below) | | |
| Allen stainless polish | Small amount on damp cloth remover. | Excellent heat tint |
| Birdsall's "Staybright" | Rub with damp cloth tint removable.Does but does scratch | Very good for heat not scratch no.4 finish no.7 |
| Wyandotte or Bob-O | Rub with damp cloth | Good for heat tint removal |
| Oxalic acid (use warm) or 5-15% nitric acid | Swab or immerse. Always follow with a 5% sodium carbonate or neutralizer rinse | Good discoloration remover |
| Best effect chemical co. cleaner & Passivator | Rub with damp cloth | May scratch no 4 finish but leaves clean surface |

CLEANERS AND THEIR EFFECT ON
STAINLESS STEEL
(Cont.)

| Cleaning agent | Method of Application | Effect on Finish |
|---|-----------------------|--|
| 3. The following detergents and solvents are excellent removers of grease, oil and fatty acids, where swabbing or rubbing is not practical. | | |
| 4 to 6% solution of (sodium Metasilicate) (Trisodium Phosphate) (Sodium Metaphosphate) (Sodium Pyrophosphate) | | All excellent removers of grease, oil, and milkstone |
| 5-15% caustic soda (hot or cold) | | Will remove grease and milkstone |
| 4. The following organic solvents may be used for removing oils and grease deposits: | | |
| Carbon-tetrachloride, Naphtha, Trichlorethylene Acetone, Kerosene, Gasoline, Ether, Alcohol, Benzene | | No affect on finish, however, take all precautions against fire. |

Notes: ordinary wool or steel brushes should never be used on stainless steel surfaces. Particles of steel may become imbedded in the stainless steel surface, and rusting of these particles will eventually appear as stains. Use stainless steel wool or sponge on stainless steel equipment. Heat tint removers will usually scratch stainless steel surfaces. This, however, is necessary in removing heat tint by hand. Oakite, a fibrous material, may be used in place of metal sponges or cloth pads for applying cleaners and polishes. This material is effective in aiding in removal of milkstone.

For heavy hard water deposits, 15-20% (by volume) nitric acid is very effective. Acid treatment should be followed by a thorough water rinse.

The action of soldering fluxes should be neutralized immediately with a 5% sodium carbonate solution.

Soap and water followed by a water rinse will not harm stainless steel.

PREVENTATIVE MAINTENANCE OF COLORPOINT EQUIPMENT

To insure that your equipment will continue to operate properly, please follow these simple steps:

1. The food receptacle wells should be clean thoroughly every day. Food spillage left in the pans such as tomato paste can cause damage to the unit. The acidic base of foods over time can cause pitting of the units. For more cleaning information on these models, see the section on "HOW TO CLEAN STAINLESS STEEL" in this manual.
2. Always wipe the unit down with a damp cloth. Do not spray water directly in control panel areas or on areas with exposed heating elements.
3. Where applicable, clean sneeze guards daily. See the section on cleaning plexiglass.

LOW TEMP INDUSTRIES
TYPICAL FOLD DOWN BRACKET
USED FOR BOTH TRAY SLIDES
AND CUTTING BOARDS

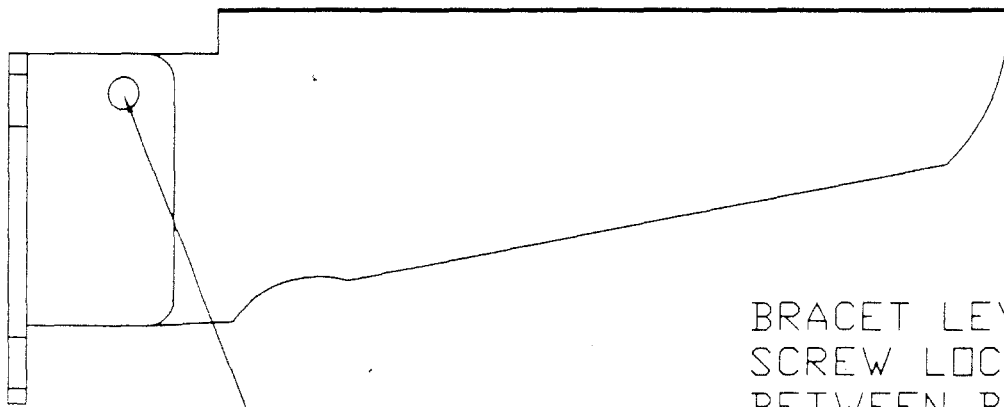

BRACKET LEVEL ADJUSTMENT
SCREW LOCATED ON HEAL PLATE
BETWEEN BRACKET SUPPORTS.
(3/8" ADJUSTMENT)

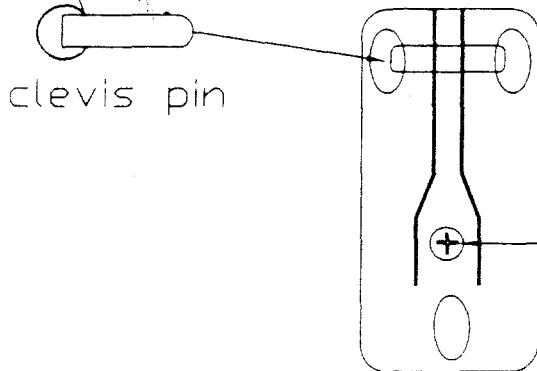

clevis pin

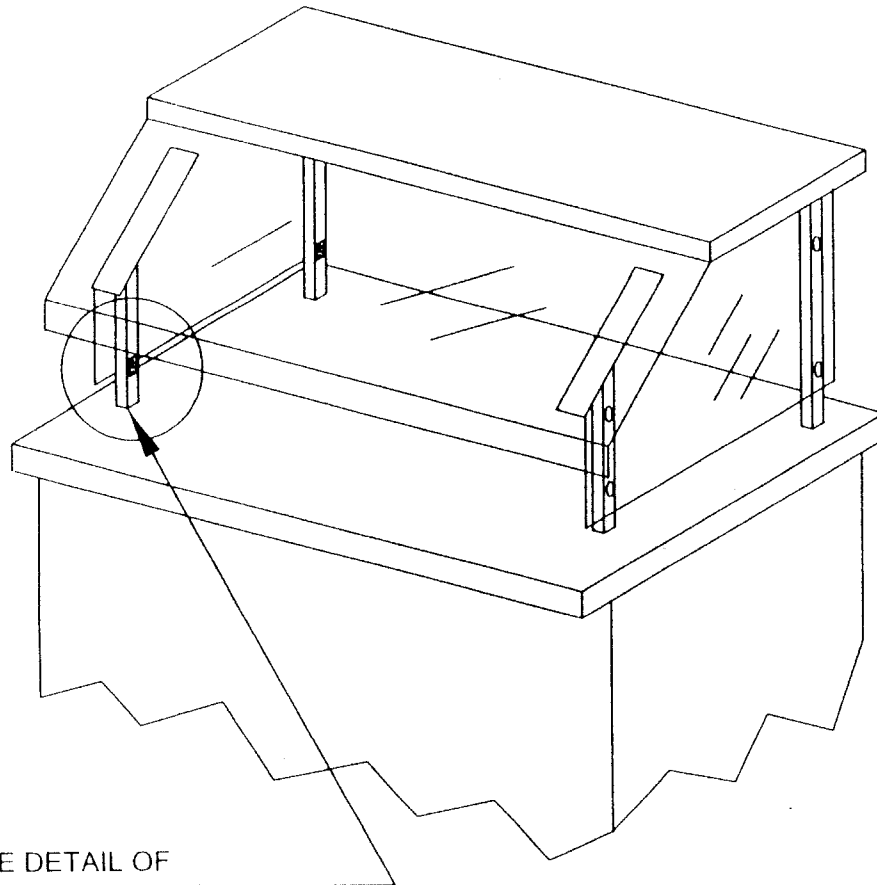

SEE DETAIL OF
ADJUSTABLE LEG

ADJUSTABLE BUFFET FOOD PROTECTOR

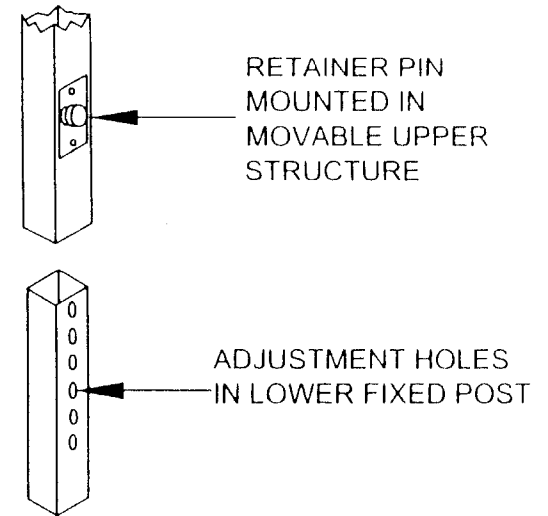

ADJUSTABLE LEG DETAIL

ADJUSTABLE BUFFET SHIELD INSTRUCTIONS

THIS UNIT IS PROVIDED WITH AN ADJUSTABLE BUFFET SHIELD THE TOTAL ADJUSTMENT IS SIX (6) INCHES FROM ITS LOWEST POSITION IN ONE (1) INCH INCREMENTS.

TO ADJUST THE SHIELD PULL THE RETAINER PIN LOCATED ON EACH POST OUT. THE PIN WILL REMAIN IN THE OUT POSITION BY ROTATING IT ONE QUARTER (1/4) TURN. RAISE THE SHIELD TO THE DESIRED HEIGHT AND TURN RETAINER BACK TO ITS ORIGINAL POSITION.

NOTE! WHEN RAISING THE SHIELD BOTH ENDS MUST BE LIFTED AT THE SAME TIME. DO NOT FORCE THE POST OR PUT THE SYSTEM IN A BIND.

IF ELECTRICAL DEVICES ARE PROVIDED ON THE SHIELD, LOOSEN THE LOCKING COLLAR ON THE WIRE CHASE POST, WHICH IS LOCATED BETWEEN THE MAIN SUPPORT POST, AND SET IT FLUSH WITH THE COUNTER TOP.

COLORPOINT

BY LOW TEMP INDUSTRIES
JONESBORO, GEORGIA

5-02

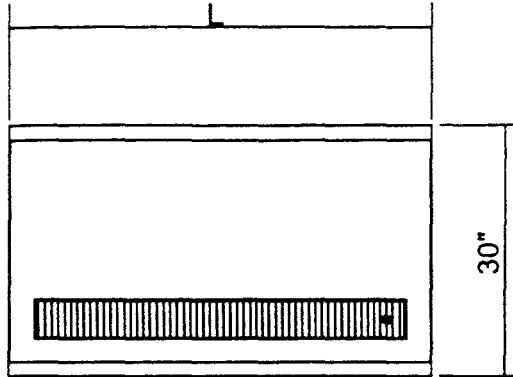

TOP VIEW

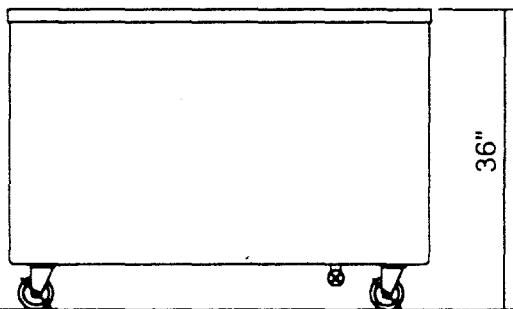

SIDE VIEW

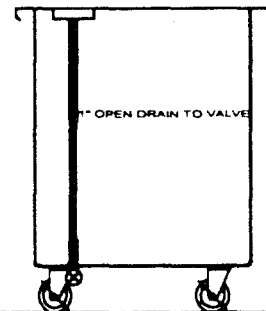

SECTIONAL VIEW

| MODEL | L | SHIPPING WT |
|-------|-----|-------------|
| 36-BT | 36" | 180 |
| 50-BT | 50" | 230 |
| 60-BT | 60" | 255 |
| 66-BT | 66" | 265 |
| 74-BT | 74" | 280 |
| 96-BT | 96" | 330 |

TOP: 14 GAUGE STAINLESS STEEL WITH SQUARE TURN DOWNS ON ALL SIDES AND CORNERS FULLY WELDED AND GROUND AND POLISHED TO A #4 SATIN FINISH WITH ALL EDGES HAVING A #7 HL-LITE FINISH.

BODY: SEAMLESS MOLDED FIBERGLASS (F.R.P.) WITH SMOOTH EXTERIOR SURFACE AND ROUNDED CORNERS. ALL FIBERGLASS TO BE FLAME RETARDANT PER SPECIFICATIONS ASTM-E-162 HAVING A FLAME SPREAD OF 25 OR LESS.

DRAIN TROUGH: 14 GAUGE STAINLESS STEEL DRAIN TROUGH WELDED INTO TOP AND FITTED WITH A REMOVABLE STAINLESS STEEL ANTI-SPLASH GRID TROUGH TO BE SLOPED TO 1" OPEN BRASS DRAIN AND EXTENDED TO SHUT OFF VALVE LOCATED BELOW BASE

CASTERS: 4" DIAMETER BALL BEARING, SWIVEL TYPE, NON MARKING WITH BRAKES ON ALL WHEELS. CASTERS TO BE MOUNTED WITH INTERNAL AND EXTERNAL BRACING FOR MAXIMUM STRESS RELIEF.

APPROVALS: THIS UNIT IS LISTED BY UNDERWRITERS LABORATORIES FOR SAFETY AND CLASSIFIED BY UNDERWRITERS LABORATORIES BY SANITATION UNDER NSF STD 2 AND SHALL BEAR BOTH SEALS.

COLORPOINT

BY LOW TEMP INDUSTRIES
JONESBORO, GEORGIA

5-02

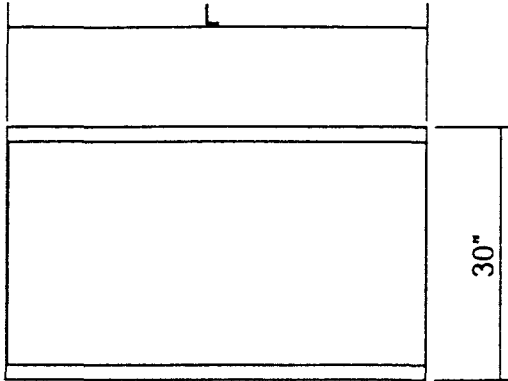

TOP VIEW

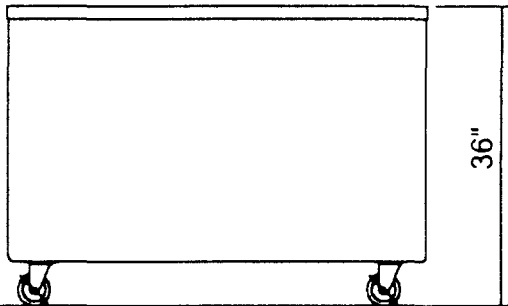

SIDE VIEW

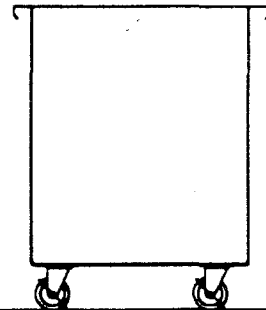

SECTIONAL VIEW

| MODEL | L | SHIPPING WT |
|-------|-----|-------------|
| 36-ST | 36" | 150 |
| 50-ST | 50" | 200 |
| 60-ST | 60" | 225 |
| 66-ST | 66" | 250 |
| 74-ST | 74" | 275 |
| 96-ST | 96" | 325 |

TOP: 14 GAUGE STAINLESS STEEL WITH SQUARE TURN DOWNS ON ALL SIDES AND CORNERS FULLY WELDED AND GROUND AND POLISHED TO A #4 SATIN FINISH WITH ALL EDGES HAVING A #7 HI-LITE FINISH.

BODY: SEAMLESS MOLDED FIBERGLASS (F.R.P.) WITH SMOOTH EXTERIOR SURFACE AND ROUNDED CORNERS. ALL FIBERGLASS TO BE FLAME RETARDANT PER SPECIFICATIONS ASTM-E-162 HAVING A FLAME SPREAD OF 25 OR LESS.

CASTERS: 4" DIAMETER BALL BEARING, SWIVEL TYPE, NON MARKING WITH BRAKES ON ALL WHEELS. CASTERS TO BE MOUNTED WITH INTERNAL AND EXTERNAL BRACING FOR MAXIMUM STRESS RELIEF.

APPROVALS: THIS UNIT IS LISTED BY UNDERWRITERS LABORATORIES FOR SAFETY AND CLASSIFIED BY UNDERWRITERS LABORATORIES BY SANITATION UNDER NSF STD 2 AND SHALL BEAR BOTH SEALS.

COLORPOINT

5-02

BY LOW TEMP INDUSTRIES
JONESBORO, GEORGIA

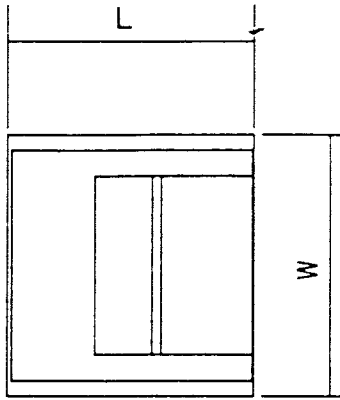

CASHIER STAND

TOP VIEW

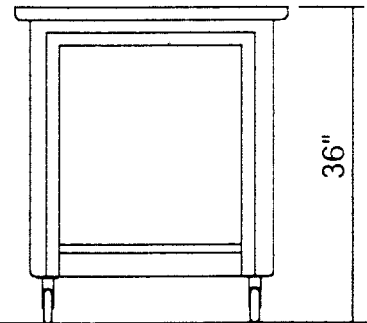
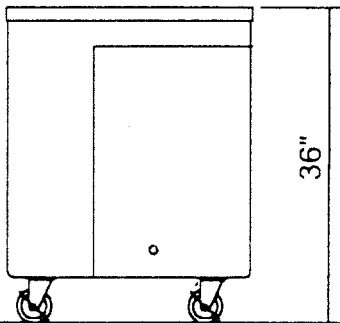

SIDE VIEW

END VIEW

| MODEL | L X W X H | SHIPPING WT |
|--------|--------------|-------------|
| 28-CSE | 30 X 28 X 36 | 205 |
| 28-CSS | 28 X 30 X 36 | 205 |
| 36-CSE | 36 X 30 X 36 | 220 |
| 36-CSS | 30 X 36 X 36 | 220 |

TOP: 14 GAUGE STAINLESS STEEL WITH SQUARE TURN DOWNS ON ALL SIDES AND CORNERS FULLY WELDED AND GROUND AND POLISHED TO A #4 SATIN FINISH WITH ALL EDGES HAVING A #7 HL-LITE FINISH.

BODY INTERIOR: OPEN UNDERSTORAGE TO BE LINED WITH 18 GAUGE STAINLESS STEEL WITH COVERED VERTICAL CORNERS AND HORIZONTAL CORNERS A 1" STAINLESS STEEL FOOT REST SHALL BE SECURED TO THE INTERIOR WALLS.

BODY: SEAMLESS MOLDED FIBERGLASS (F.R.P.) WITH SMOOTH EXTERIOR SURFACE AND ROUNDED CORNERS. ALL FIBERGLASS TO BE FLAME RETARDANT PER SPECIFICATIONS ASTM-E-162 HAVING A FLAME SPREAD OF 25 OR LESS.

CASTERS: 4" DIAMETER BALL BEARING, SWIVEL TYPE, NON MARKING WITH BRAKES ON ALL WHEELS. CASTERS TO BE MOUNTED WITH INTERNAL AND EXTERNAL BRACING FOR MAXIMUM STRESS RELIEF.

APPROVALS: THIS UNIT IS LISTED BY UNDERWRITERS LABORATORIES FOR SAFETY AND CLASSIFIED BY UNDERWRITERS LABORATORIES BY SANITATION UNDER NSF STD 2 AND SHALL BEAR BOTH SEALS.

COLORPOINT

BY LOW TEMP INDUSTRIES
JONESBORO, GEORGIA

5-02

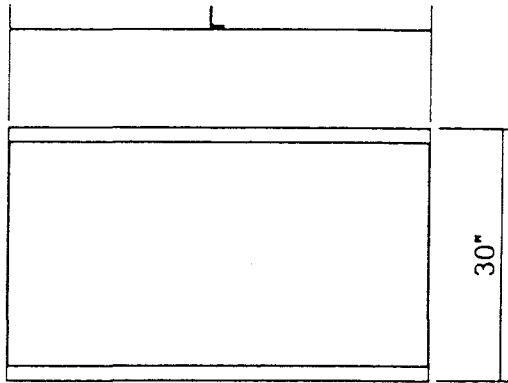

TOP VIEW

WORK TABLE

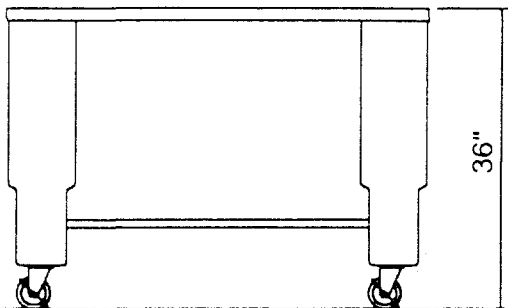

SIDE VIEW

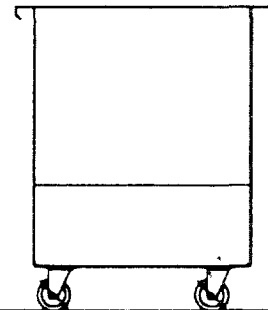

SECTIONAL VIEW

| MODEL | L | SHIPPING WT |
|-------|-----|-------------|
| 3-WT | 36" | 110 |
| 4-WT | 48" | 165 |
| 5-WT | 60" | 220 |
| 6-WT | 72" | 250 |

TOP: 14 GAUGE STAINLESS STEEL WITH SQUARE TURN DOWNS ON ALL SIDES AND CORNERS FULLY WELDED AND GROUND AND POLISHED TO A #4 SATIN FINISH WITH ALL EDGES HAVING A #7 HI-LITE FINISH.

PYLON BASES: SEAMLESS MOLDED FIBERGLASS (F.R.P.) WITH SMOOTH EXTERIOR SURFACE AND ROUNDED CORNERS. ALL FIBERGLASS TO BE FLAME RETARDANT PER SPECIFICATIONS ASTM-E-162 HAVING A FLAME SPREAD OF 25 OR LESS.

CASTERS: 4" DIAMETER BALL BEARING, SWIVEL TYPE, NON MARKING WITH BRAKES ON ALL WHEELS. CASTERS TO BE MOUNTED WITH INTERNAL AND EXTERNAL BRACING FOR MAXIMUM STRESS RELIEF.

APPROVALS. THIS UNIT IS LISTED BY UNDERWRITERS LABORATORIES FOR SAFETY AND CLASSIFIED BY UNDERWRITERS LABORATORIES BY SANITATION UNDER NSF STD 2 AND SHALL BEAR BOTH SEALS

COLORPOINT

BY LOW TEMP INDUSTRIES
JONESBORO, GEORGIA

5-02

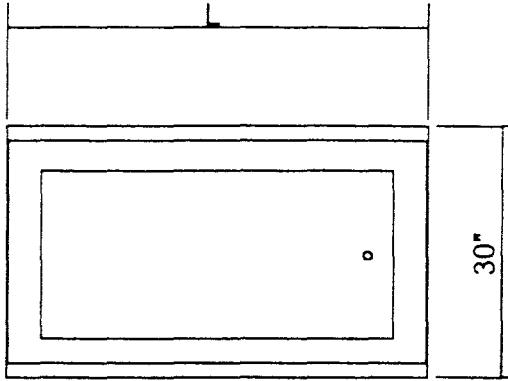

TOP VIEW

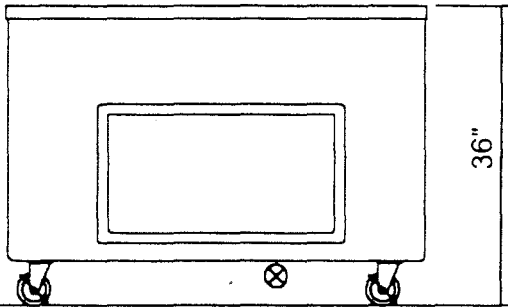

SIDE VIEW

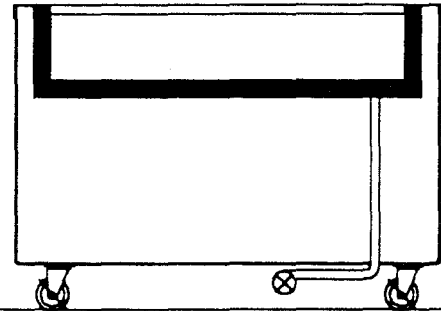

SECTIONAL VIEW

| MODEL | L | SHIPPING WT |
|--------|-----|-------------|
| 36-CFI | 36" | 225 |
| 50-CFI | 50" | 275 |
| 60-CFI | 60" | 300 |
| 66-CFI | 66" | 315 |
| 74-CFI | 74" | 325 |
| 96-CFI | 96" | 375 |

TOP: 14 GAUGE STAINLESS STEEL WITH SQUARE TURN DOWNS ON ALL SIDES AND CORNERS FULLY WELDED AND GROUND AND POLISHED TO A #4 SATIN FINISH WITH ALL EDGES HAVING A #7 HL-LITE FINISH.

COLD PAN: THE ICE COOLED COLD PAN SHALL BE 18 GAUGE STAINLESS STEEL AND BE 6" DEEP OR AS REQUIRED. THE WELDED WATERTIGHT PAN TO BE FULLY INSULATED WITH URETHANE INSULATION WITH SECTIONAL, REMOVABLE FALSE BOTTOM. A FULL PERIMETER FORMICA BREAKER STRIP SHALL SEPERATE THE TOP FROM THE COLD PAN. PAN TO HAVE A 1" OPEN BRASS DRAIN WITH EXTENSION TO SHUT-OFF VALVE BELOW BASE.

BODY: SEAMLESS MOLDED FIBERGLASS (F.R.P) WITH SMOOTH EXTERIOR SURFACE AND ROUNDED CORNERS. ALL FIBERGLASS TO BE FLAME RETARDANT PER SPECIFICATIONS ASTM-E-162 HAVING A FLAME SPREAD OF 25 OR LESS.

CASTERS: 4" DIAMETER BALL BEARING, SWIVEL TYPE, NON MARKING WITH BRAKES ON ALL WHEELS. CASTERS TO BE MOUNTED WITH INTERNAL AND EXTERNAL BRACING FOR MAXIMUM STRESS RELIEF.

APPROVALS: THIS UNIT IS LISTED BY UNDERWRITERS LABORATORIES FOR SAFETY AND CLASSIFIED BY UNDERWRITERS LABORTORIES BY SANITION UNDER NSF STD 2 AND SHALL BEAR BOTH SEALS.

COLORPOINT

5-02

BY LOW TEMP INDUSTRIES
JONESBORO, GEORGIA

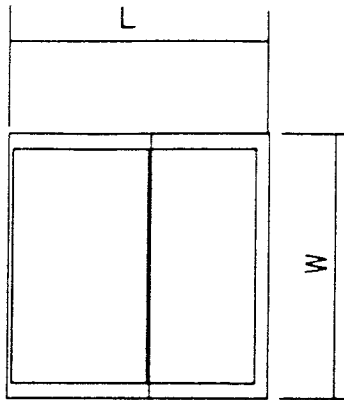

TOP VIEW

TRAY STAND

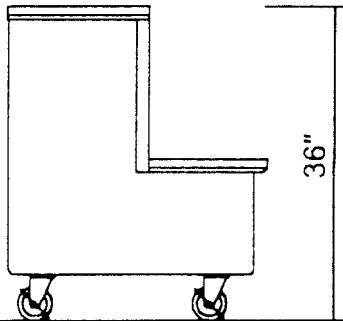

SIDE VIEW

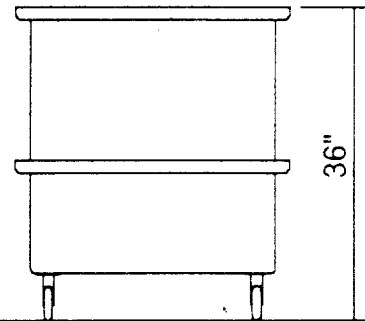

END VIEW

| MODEL | L X W X H | SHIPPING WT |
|--------|--------------|-------------|
| 36-RTE | 38 X 30 X 36 | 220 |
| 36-RTS | 30 X 36 X 36 | 220 |
| 28-RTE | 30 X 30 X 36 | 205 |
| 28-RTS | 30 X 28 X 36 | 205 |

TOP: 14 GAUGE STAINLESS STEEL WITH SQUARE TURN DOWNS ON ALL SIDES AND CORNERS FULLY WELDED AND GROUND AND POLISHED TO A #4 SATIN FINISH WITH ALL EDGES HAVING A #7 HI-LITE FINISH.

BODY: SEAMLESS MOLDED FIBERGLASS (F.R.P.) WITH SMOOTH EXTERIOR SURFACE AND ROUNDED CORNERS. ALL FIBERGLASS TO BE FLAME RETARDANT PER SPECIFICATIONS ASTM-E-162 HAVING A FLAME SPREAD OF 25 OR LESS.

CASTERS: 4" DIAMETER BALL BEARING, SWIVEL TYPE, NON MARKING WITH BRAKES ON ALL WHEELS. CASTERS TO BE MOUNTED WITH INTERNAL AND EXTERNAL BRACING FOR MAXIMUM STRESS RELIEF.

APPROVALS: THIS UNIT IS LISTED BY UNDERWRITERS LABORATORIES FOR SAFETY AND CLASSIFIED BY UNDERWRITERS LABORATORIES BY SANITATION UNDER NSF STD 2 AND SHALL BEAR BOTH SEALS.

TROUBLE SHOOTING SERVICE CHART

SERVICE TO BE PREFORMED BY QUALIFIED SERVICE TECHNICIAN ONLY.

| <u>COMPLAINT</u> | <u>PROBLEM</u> | <u>SOLUTION</u> |
|--------------------------|---|---|
| HEAT LAMPS WILL NOT HEAT | 1. PLUG DISCONNECTED CONNECTIONS | 1. CHECK ALL ELECTRICAL CONNECTIONS |
| | 2. LINE SWITCH OPEN | 2. CLOSE SWITCH |
| | 3. BREAKER TRIPPED | 3. RESET BREAKER |
| | 4. HEATER ELEMENT BURNED OUT OR DEFECTIVE | 4. REPLACE |
| | 5. FUSE BLOWN | 5. REPLACE |
| | 6. LOW VOLTAGE | 6. USING SUITABLE INSTRUMENT CHECK LINE VOLTAGE AND AMPERAGE. VOLTAGE MUST BE WITHIN 10 % OR NAME PLATE RATING. |
| LIGHTS WILL NOT BURN | 1. PLUG DISCONNECTED | 1. CHECK ALL ELECTRICAL CONNECTIONS |
| | 2. LINE SWITCH OPEN | 2. CLOSE SWITCH |
| | 3. BREAKER TRIPPED | 3. RESET BREAKER |
| | 4. FUSE BLOWN | 4. REPLACE FUSE |
| | 5. BULB BLOWN | 5. REPLACE BULB |
| | 6. STARTER DEFECTIVE | 6. REPLACE STARTER |
| | 7. BAD BALLAST | 7. REPLACE BALLAST |

REPLACEMENT PARTS LIST

| ITEM NO. | DESCRIPTION | STOCK NO. | MFG. NO. | MANUFACTURER |
|----------|----------------------|-----------|-----------|-------------------|
| 1 | CASTERS 4" W/ BRAKES | 130810 | 2-4056-43 | JARVIS AND JARVIS |

ADDITIONAL OPTIONS AVAILABLE

| | | | | |
|----|--|--------|----------------|-----------------------|
| 2 | SWITCH SINGLE POLE (BALL BAT LIGHT SWITCH) | 335900 | 90-0001 | McGILL |
| 3 | SWITCH DOUBLE POLE (BALL BAT HEAT LAMP SWITCH) | 335920 | 0121-0001 | McGILL |
| 4 | TUNGSTEN SWITCH (PADDLE SWITCH USED WITH BULLET TYPE HEAT LAMPS) | 335911 | TA115PWBXGC1 | CARLING |
| 5 | FLUORESCENT FIXTURE | 360700 | M15L | NULITE |
| 6 | FLUORESCENT BULB | 358100 | F15T8/CW | SYLVANIA |
| 7 | BULB SLEEVE & CAP | 493510 | 18" T8 | TRU-TEST |
| 8 | SINGLE PORCELAIN SOCKET (USED WITH BULLET TYPE HEAT LAMP OR INCANDESCENT BULBS NOT IN HEAT LAMPS) | 360610 | 10035-000 | LEVITON |
| 9 | DOUBLE PORCELAIN SOCKET (USED WITH INCANDESCENT BULB NOT IN HEAT LAMPS) | 533800 | 4010 | LEVITON |
| 10 | BULLET HEAT LAMPS (250 W / 120 V / CLEAR WITH TOUGH SKIN COATING) | 357800 | 250R40/1CVG | GENERAL ELECTRIC |
| 11 | INCANDESCENT BULBS (40 W / 120 V / APPLIANCE BULBS WITH TOUGH SKIN COATING) | 494300 | R79-0040 | COMPONENT HARDWARE |
| 12 | FUSE HOLDER | 358210 | 571027 | LITTLE FUSE |
| 13 | STOCK FUSES | | | |
| | 1A | 513800 | SLC-1 CLASS G | LITTLE FUSE |
| | 2A | 513810 | SLC-2 CLASS G | LITTLE FUSE |
| | 4A | 513820 | SLC-4 CLASS G | LITTLE FUSE |
| | 5A | 513830 | SLC-5 CLASS G | LITTLE FUSE |
| | 6A | 513840 | SLC-6 CLASS G | LITTLE FUSE |
| | 8A | 513850 | SLC-8 CLASS G | LITTLE FUSE |
| | 10A | 513860 | SLC-10 CLASS G | LITTLE FUSE |
| | 15A | 513870 | SLC-15 CLASS G | LITTLE FUSE |
| | 20A | 513880 | SLC-20 CLASS G | LITTLE FUSE |

NOTE! REPLACE WITH SAME TYPE AND AMPERAGE FUSE. CHECK YOUR UNIT FOR THE SPECIFIC FUSE USED.

FOR REPLACEMENT HEAT LAMPS SPECIFY SPECIFIC MODEL NUMBER FROM HEAT LAMP

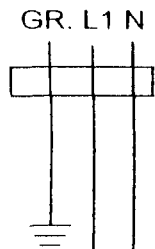

SPECIFIC PLUG WILL VARY DEPENDING UPON OPTIONS PURCHASED. CONSULT FACTORY FOR SPECIFIC PLUG AND POWER REQUIREMENTS

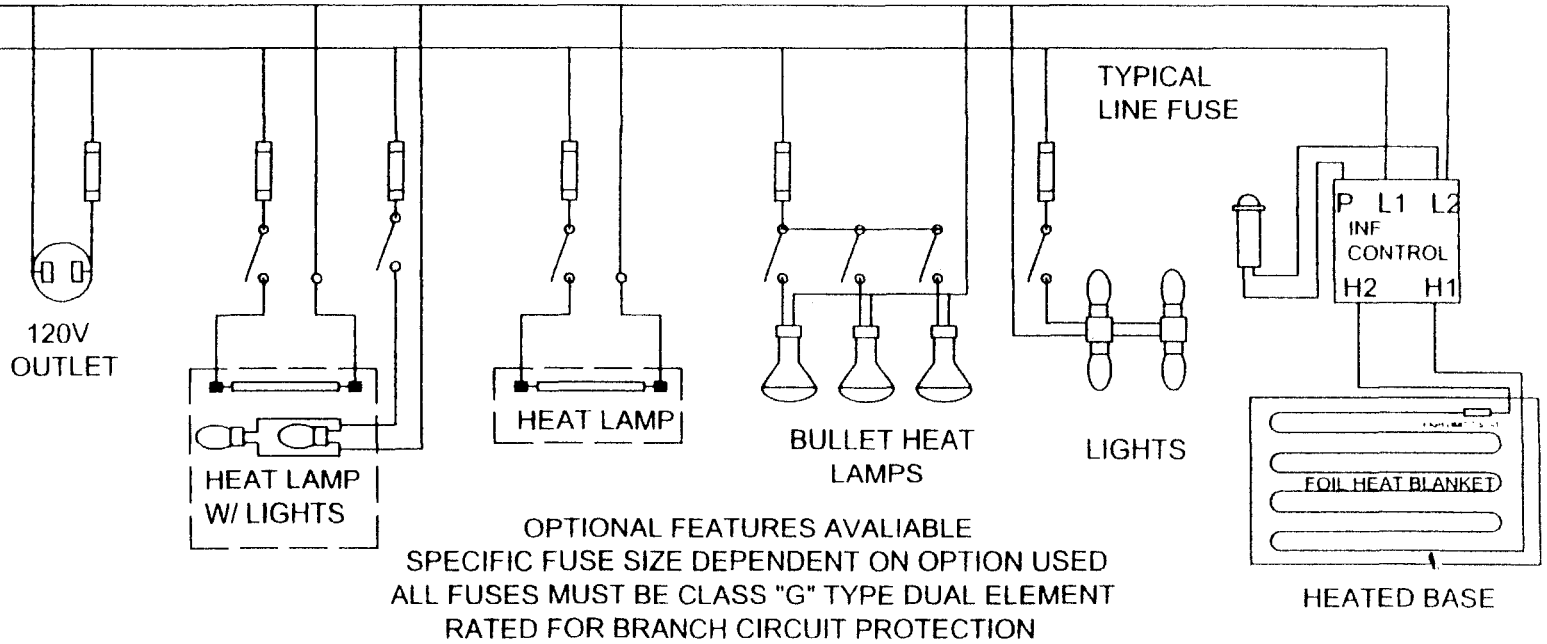

OPTIONAL FEATURES AVAILABLE
 SPECIFIC FUSE SIZE DEPENDENT ON OPTION USED
 ALL FUSES MUST BE CLASS "G" TYPE DUAL ELEMENT
 RATED FOR BRANCH CIRCUIT PROTECTION

LOW TEMP INDUSTRIES INC.
 JONESBORO, GEORGIA

WIRING DIAGRAM
 120V/ 1PH

WIRING DIARGAM
 NO. LT-ENG-WD 021TT

REV: 5-23-02 TT

DATE 4-7-95

SPECIFIC PLUG WILL VARY DEPENDING UPON OPTIONS PURCHASED. CONSULT FACTORY FOR SPECIFIC PLUG AND POWER REQUIREMENTS

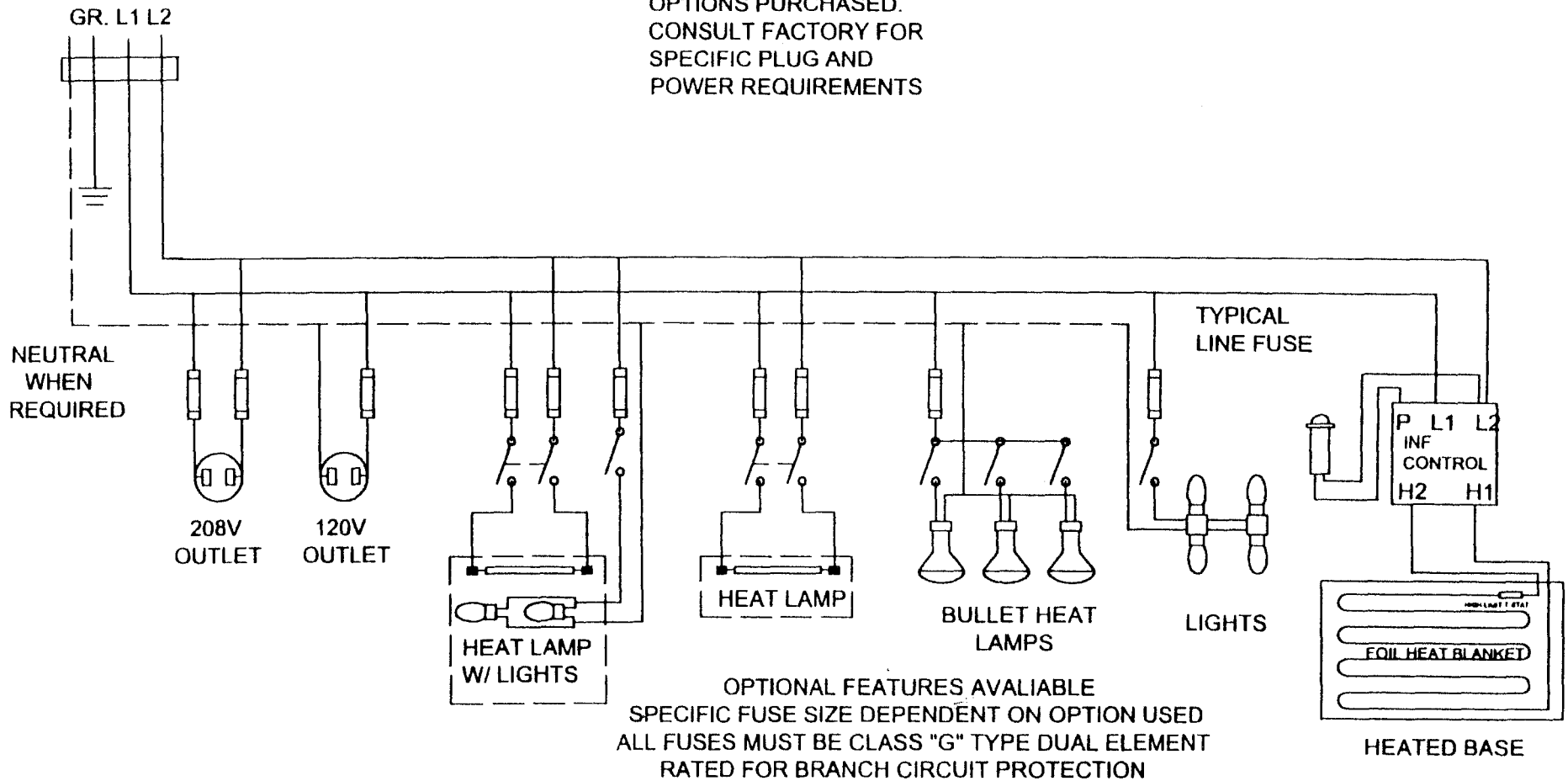

LOW TEMP INDUSTRIES INC.
JONESBORO, GEORGIA

WIRING DIAGRAM
120-208V/ 1PH

WIRING DIARGAM
NO. LT-ENG-WD 020TT

REV: 5-23-02 TT

DATE 4-7-95

ONE YEAR WARRANTY

ALL COLORPOINT FOOD SERVICE EQUIPMENT IS FULLY WARRANTED BY THE MANUFACTURER AGAINST DEFECTS IN MATERIALS OR WORKMANSHIP FOR A PERIOD OF ONE (1) YEAR FROM THE DATE OF PURCHASE BY THE ORIGINAL USER AND ONLY TO THE ORIGINAL PURCHASER PROVIDED IT IS INSTALLED AND OPERATED IN ACCORDANCE WITH THE INSTRUCTIONS SUPPLIED WITH THE UNIT. ALSO, IT MUST NOT BE MISUSED, ALTERED OR NEGLECTED AND USED ONLY ON CIRCUITS AND VOLTAGES REQUIRED FOR THAT UNIT.

OUR OBLIGATION UNDER THIS WARRANTY SHALL BE LIMITED TO ONE OF THE FOLLOWING PROCEDURES. SELECTION OF A PROCEDURE SHALL BE AT THE SOLE DISCRETION OF LOW TEMP INDUSTRIES INC.

LOW TEMP INDUSTRIES, INC. WARRANTY SERVICE DEPARTMENT MUST BE NOTIFIED PRIOR TO ANY SERVICE WORK FOR A WARRANTY AUTHORIZATION NUMBER. ANY REQUESTS FOR WARRANTY CLAIMS WITHOUT A WARRANTY AUTHORIZATION NUMBER, WILL NOT BE HONORED.

- A. REPLACEMENT OF DEFECTIVE PARTS, SHIPPED F.O.B. FACTORY, IN EXCHANGE FOR THE RETURNED DEFECTIVE PART, SHIPPED PREPAID FREIGHT.
- B. FREE REPLACEMENT OF DEFECTIVE PART, SHIPPED F.O.B. FACTORY.
- C. DEFECTIVE PART SHIPPED PREPAID FREIGHT TO FACTORY, REPAIRED AND RETURNED, SHIPPED F.O.B. . FACTORY.
- D. ALL LABOR COSTS SHALL BE COVERED FOR A PERIOD OF 1 YEAR FROM THE DATE OF PURCHASE.

LOW TEMP INDUSTRIES INC. SHALL NOT BE RESPONSIBLE FOR ANY DAMAGE CAUSED BY FIRE, FLOOD, WINDSTORM, OR ANY OTHER ACT OF GOD; WAR, WHETHER DECLARED OR UNDECLARED NOR SHALL WE BE RESPONSIBLE FOR THE LOSS OF FOOD OR OTHER PRODUCTS DUE TO POWER OR MECHANICAL FAILURE. THIS WARRANTY SHALL NOT COVER ANY DAMAGE CAUSED DURING SHIPMENT WHICH SHOULD BE REPORTED TO THE DELIVERING CARRIER.

COLORPOINT FIBERGLASS FOOD SERVICE EQUIPMENT

A DIVISION OF LOW TEMP INDUSTRIES INC.
9192 TARA BOULEVARD
JONESBORO, GEORGIA 30236
(770) 478-8803