

ISSUE DATE: 8/06

OPERATION AND MAINTENANCE MANUAL REPLACEMENT PARTS LIST FOR



**5E2-CPA THRU 5E6-CPA
SERIES
HOT FOOD
SERVING TABLES**

 **COLORPOINT**
DIVISION OF LOW TEMP INDUSTRIES, INC.

9192 TARA BOULEVARD P.O. BOX 795 JONESBORO, GEORGIA 30237
TELEPHONE: (770) 478-8803

FIBERGLASS SERVING EQUIPMENT

INSPECTION

UPON RECEIPT, THE CRATE SHOULD BE INSPECTED FOR VISUAL DAMAGE. ANY DAMAGE SHOULD BE REPORTED IMMEDIATELY TO THE CARRIER.

INSTALLATION INSTRUCTIONS

COLOR POINT 5E SERIES HOT FOOD UNITS ARE DESIGNED FOR DISPENSING FOOD. THIS UNIT IS DESIGNED TO HELP MAINTAIN A PRODUCT TEMPERATURE AT A MINIMUM OF 140 DEGREES FAHRENHEIT DURING SERVING PERIODS. THE 5E SERIES ARE AVAILABLE WITH HEATED UNDER STORAGE. THIS UNITS DESIGNED FOR ON LINE STORAGE OF PRODUCT. THEY SHOULD NOT BE USED AS LONG TERM STORAGE OF BULK PRODUCT. THE DESIGN OF THIS UNIT ALLOWS FOR A MODULAR OPERATION, WHERE A GROUP OF UNITS CAN BE ARRANGED TO FORM A CAFETERIA SERVING LINE. ROLL THE TABLE INTO A SERVING LINE OR OTHER NEEDED POSITION AND LOCK THE BRAKES ON THE CASTERS.

IF LINE UP LOCKS ARE PROVIDED, SIMPLY ALIGN THE UNITS AND PUSH THE BARREL BOLTS THROUGH THE KEY HOLE SLOTS ON BOTH UNITS THEN TURN THE BOLT DOWN AND PUSH UP THE CAM LOCKING LEVER. TO UNLOCK THE UNITS, REVERSE THIS PROCEDURE.

PLUG THE UNIT INTO THE PROPER GROUNDED ELECTRICAL OUTLET. THE UNIT IS NOW READY FOR OPERATION.

OPERATING INSTRUCTIONS

HOT FOOD SECTION:

SINCE THE FOOD WARMING UNIT IS DESIGNED FOR HOLDING OR WARMING PRECOOKED FOOD, IT WILL NOT OVERCOOK FOOD WHEN PROPERLY USED. THERE ARE THREE (3) WAYS OF MAINTAINING HOT FOOD IN THE RECEPTACLE: 1. DRY HEATING, 2. STEAM HEATING AND 3. HOT WATER HEATING.

1. DRY HEATING

- A. PLACE THE CONTROL KNOB ON THE DESIRED POSITION AND ALLOW THE RECEPTACLE TO PREHEAT FOR 15 TO 20 MINUTES.
- B. PLACE THE CONTAINER OF FOOD IN THE RECEPTACLE. KEEP THE FOOD COVERED WHEN NOT SERVING.

***** WARNING *****

NEVER POUR COLD WATER INTO A HOT FOOD PAN RECEPTACLE. IF THE WATER BOILS OUT, REFILL WITH HOT WATER OR WAIT UNTIL WELL HAS COOLED DOWN. IF COLD WATER IS Poured ON A HOT, EMPTY RECEPTACLE IT WILL CAUSE THE WELL TO SPLIT OR CRACK.

2. STEAM HEATING

- A. PLACE A FEW QUARTS OF COLD WATER OR HOT WATER (FOR A FASTER PRE-HEAT) IN TO THE RECEPTACLE. THE WATER SHOULD NOT BE IN CONTACT WITH THE FOOD PAN.
- B. PLACE A COVER OR EMPTY FOOD PAN OVER THE RECEPTACLE AND SET THE THERMOSTAT TO A POSITION FOR MODERATE BOILING. ALLOW UNIT TO PREHEAT UNTIL WATER BOILS.
- C. PLACE THE CONTAINER OF FOOD IN THE RECEPTACLE. KEEP FOOD COVERED WHEN NOT BEING SERVED.
- D. ADJUST THE THERMOSTAT TO A POINT WHERE THE WATER JUST BOILS.

2. HOT WATER

- A. FILL THE RECEPTACLE WITH HOT WATER TO A DEPTH SO THAT THE FOOD CONTAINER WILL BE IN CONTACT WITH THE WATER.
- B. PLACE A COVER OR EMPTY FOOD PAN OVER THE RECEPTACLE AND SET THE THERMOSTAT TO A POSITION FOR MODERATE BOILING. ALLOW UNIT TO PREHEAT UNTIL WATER BOILS.
- C. LOWER THE SETTING ON THE THERMOSTAT SLIGHTLY SO THAT THE WATER TEMPERATURE IS JUST BELOW THE BOILING POINT.
- D. PLACE THE CONTAINER OF FOOD IN THE RECEPTACLE. KEEP FOOD COVERED WHEN NOT BEING SERVED.

EXACT DIAL SETTING TO MAINTAIN DESIRED FOOD TEMPERATURE WILL VARY WITH THE CHARACTER OF THE FOOD, SUCH AS WHETHER OR NOT THE FOOD IS WATERY OR HAS A CONSIDERABLE AMOUNT OF GREASE. THE MOST SATISFACTORY TEMPERATURE SETTING MUST BE DETERMINED BY EXPERIENCE.

WITH STEAM AND HOT WATER HEATING THE DRYING THE DRYING OUT OF THE FOOD IS MINIMIZED BECAUSE THE WATER VAPOR FROM THE RECEPTACLES CREATES HUMID AIR OVER THE FOOD.

THERMOSTAT:

THE THERMOSTAT BULB IS CLAMPED TO THE OUTSIDE OF THE DEFLECTOR PLATE ON THE BOTTOM OF THE RECEPTACLE. A CAPILLARY TUBE EXTENDS FROM THE BULB TO THE THERMOSTAT CONTROL. WHENEVER THE HEATING UNIT IS ENERGIZED THE PILOT LIGHT BLOWS AND GOES OFF WHEN THE PRESET TEMPERATURE IS REACHED. THE CYCLING OF THE THERMOSTAT IS THEREFORE INDICATED BY THE PILOT LIGHT.

SHUTDOWN:

AT THE END OF THE DAY OR SERVING PERIOD, TURN THE THERMOSTAT CONTROLS TO THE OFF POSITION. THIS REMOVES ALL POWER TO THE HEATING UNITS. TO SHUT OFF THE EQUIPMENT FOR LONG PERIODS OF TIME OR TO PREVENT THE UNAUTHORIZED USE OF THE EQUIPMENT PLACE THE **CIRCUIT BREAKER** TO THE **OFF** POSITION.

CLEANING

HOT FOOD WELLS:

WET OPERATION - IF HOT WATER OR STEAM HEATING IS USED, ALL SURFACES ARE COVERED WITH A FILM OF WATER. FOOD SPILLAGE INTO THE RECEPTACLE WILL NOT STICK OR CARBONIZE. IT WILL DROP IN TO THE WATER AN FLOAT OR SETTLE TO THE BOTTOM. TO CLEAN THE RECEPTACLE, REMOVE THE WATER BY OPENING THE DRAIN VALVE LOCATED UNDER THE UNIT AND DRAIN THE WATER IN TO A SUITABLE CONTAINER AND SPONGE OUT THE REMAINING WATER. WASH THE RECEPTACLE WITH A MILD DETERGENT AND HOT WATER, RINSE AND DRY. SEE THE FOLLOWING SECTION ON "**HOW TO CLEAN STAINLESS STEEL**" FOR SPECIFIC RECOMMENDATIONS.

DRY OPERATION - WHEN THE FOOD WARMER IS USED DRY, FOOD SPILLAGE ON THE HOT SURFACES WILL BURN AND STICK. THE SAME COMMERCIAL CLEANERS USED ON STAINLESS STEEL UTENSILS MAY BE USED TO CLEAN THE RECEPTACLE. WASH THE INTERIOR SURFACES WITH WATER AND A MILD DETERGENT TO REMOVE DISCOLORATION. RINSE WITH PLAIN WATER AND DRY WITH AN ABSORBENT CLOTH. THE BOTTOM OF THE RECEPTACLE MAY TAKE ON A STRAW COLORED APPEARANCE WHEN IT IS USED DRY. THIS IS DUE TO THE INTENSE HEAT. THE DISCOLORATION WILL NOT COME OFF WITH NORMAL CLEANING PROCEDURES BUT DOES NOT POSE ANY PERFORMANCE OR HEALTH PROBLEMS. SEE THE SECTION ON "**HOW TO CLEAN STAINLESS STEEL**" FOR SPECIFIC RECOMMENDATIONS.

***** WARNING *****

DO NOT USE HARSH CHEMICALS, ACIDS OR ALKALIS IN CLEANING THIS TABLE OR HEATING RECEPTACLES. WITH ANY CLEANERS, READ INSTRUCTIONS CAREFULLY AND DILUTE AS INSTRUCTED BEFORE APPLYING TO STAINLESS STEEL EQUIPMENT.

THE FOOD WARMING RECEPTACLE IS MADE OF STAINLESS STEEL, BUT USE CARE DURING THE CLEANING OPERATION. HEAVY OBJECTS SHOULD NOT BE DROPPED IN THE RECEPTACLE.

CONTROL KNOB:

TO CLEAN THE THERMOSTAT KNOB, PULL THE KNOB OUTWARD TO REMOVE IT FROM THE SHAFT. WASH THE KNOB WITH MILD SOAP AND WATER, RINSE AND DRY WITH A SOFT CLOTH. DO NOT USE ABRASIVE CLEANERS ON THE PLASTIC SURFACES OF THE KNOB.

FIBERGLASS BODY:

THE FIBERGLASS BODY SHOULD BE CLEANED WITH A MILD NON-ABRASIVE CLEANER AND A SOFT CLOTH.

***** CAUTION *****

DO NOT USE BLEACHES, ABRASIVE CLEANERS OR ABRASIVE CLOTHS OR PADS AS THEY MAY DISCOLOR AND SCRATCH THE FIBERGLASS. DO NOT USE HARSH CHEMICALS, ACIDS OR ALKALIS IN THE CLEANING OF THE FIBERGLASS.

PLEXIGLASS SHIELDS:

USE A MILD SOAP AND A SOFT CLOTH WHEN CLEANING THE PLEXIGLASS SURFACES. WIPING THE SURFACE WITH A DRY CLOTH CAN CAUSE SCRATCHES.

DO NOT USE WINDOW CLEANING SPRAY OR KITCHEN SCOURING COMPOUNDS. PRODUCTS WITH A HIGH ALCOHOL CONTENT CAN CAUSE SURFACE FISSURES COMMONLY REFERRED TO AS "CRAZING". THIS WILL OCCUR IN ANY SPOT THAT HAS BEEN SUBJECT TO STRESSES, SUCH AS CHIPPED OR BURNED SAW CUTS, CRACKED HOLES FLAME POLISHED EDGES, FORMED EDGES, ETC. FOR BEST RESULTS USE "NOVUS PLASTIC POLISH NO. 1".

***** WARNING *****

IN ORDER TO PREVENT ANY ELECTRICAL ACCIDENTS, THIS EQUIPMENT SHOULD BE INSTALLED AND SERVICED BY QUALIFIED MAINTENANCE PERSONNEL ONLY PER NATIONAL ELECTRICAL CODE STANDARDS.

VARIOUS OPTIONS MAY BE PURCHASED WITH THIS EQUIPMENT. WHEN THESE OPTIONS ARE PROVIDED THE ELECTRICAL CIRCUITS MAY BE SEPARATELY FUSED WITH **CLASS "G" FUSES**. IF FUSES MUST BE REPLACED **REPLACE WITH THE SAME TYPE AND AMPERAGE FUSE**.

HOW TO CLEAN STAINLESS STEEL

THE FOLLOWING INFORMATION WAS TAKEN FROM A PAMPHLET BY MR. RICHARD E. PARET, STAINLESS STEEL SPECIALIST, AMERICAN IRON AND STEEL INSTITUTE.

STAINLESS STEEL IS ONE OF THE EASIEST MATERIALS TO CLEAN AND KEEP CLEAN.

THE REASONS FOR STAINLESS STEEL'S EASE OF CLEANING ARE EASY TO SEE; THEY LIE IN THE NATURE OF THE METAL ITSELF.

1. IT'S HARD, TOUGH SURFACE. STAINLESS STEEL WILL WORK HARDER, THAT IS, THE MORE IT IS USED, THE MORE RESISTANT TO WEAR IT BECOMES. STAINLESS STEEL WILL NOT DEVELOP ROUGH SPOTS THAT HARBOR BACTERIA AND SOIL.
2. HIGH CORROSIVE RESISTANCE. STAINLESS STEEL IS PRACTICALLY UNTOUCHED BY THE CORROSIVE ATTACKS OF MOISTURE, DETERGENTS, FOOD ACIDS, BLOOD SALTS AND OTHER CORRODENTS CONNECTED WITH FOOD PREPARATION. THIS MEANS THAT STAINLESS STEEL ALWAYS HAS A BRIGHT SURFACE FREE FROM OXIDES THAT CAN AFFECT THE FLAVOR OF FOODS.

THE SECRET OF MAINTAINING STAINLESS STEEL IS FREQUENT, SCHEDULED CLEANING THAT WILL PREVENT BUILD UP OF SURFACE DEPOSITS. SURFACE DEPOSITS, IF ALLOWED TO REMAIN FOR LONG PERIODS OF TIME CAN HARM STAINLESS STEEL. STAINLESS STEEL THRIVES ON EXPOSURE TO AIR; UNDER CERTAIN CONDITIONS, THE LENGTHY DEPRIVATION OF OXYGEN BY HEAVY SOIL DEPOSITS CAN CAUSE LOCALIZED PITTING OR STAINING.

NEGLECTING THE MATERIAL IN THIS MANNER IS **DEFINITE ABUSE**, WHICH EVEN STAINLESS STEEL IS NOT IMMUNE.

TWO BASIC RULES:

1. CLEAN FREQUENTLY, AND ON A FIXED SCHEDULE.
2. SELECT THE SIMPLEST METHOD.

TO REMOVE ORDINARY DIRT AND FOOD RESIDUE FROM STAINLESS STEEL EQUIPMENT THAT OPERATES AT LOW TEMPERATURES, USE ORDINARY SOAP AND WATER AND APPLY WITH A SPONGE, FIBER BRUSH OR CLOTH. TO HASTEN ACTION, ADD EITHER SODA ASH, BAKING SODA, BORAX OR ANY OF SEVERAL NON-ABRASIVE COMMERCIAL CLEANSING AGENTS.

TO REMOVE SPLATTER OR CONDENSED VAPOR, WHICH HAVE "BAKED" ONTO THE EQUIPMENT, THE TREATMENT OUTLINED ABOVE IS OFTEN SUFFICIENT. IN OTHER CASES A GENTLE TO VIGOROUS POLISHING ACTION MAY BE NECESSARY.

FIRST TRY A PASTE MADE WITH WATER AND AMMONIA AS THE LIQUID AND EITHER MAGNESIUM OXIDE, FINELY POWDER PUMICE OR FRENCH CHALK AS THE SOLID. YOU CAN ALSO USE ONE OF SEVERAL COMMERCIAL CLEANERS LISTED IN THE FOLLOWING TABLE.

RUB AS GENTLY AS POSSIBLE IN THE DIRECTION OF THE POLISHING MARKS ON THE STEEL, USING A SOFT CLOTH. FOR MORE RESISTANT DEPOSITS, USE A STAINLESS STEEL SCOURING SPONGE OR STAINLESS STEEL WOOL OF THE FINEST POSSIBLE TEXTURE.

WHAT NOT TO DO:

DO NOT USE COMMON STEEL WOOL, SCOURING PADS, SCRAPERS, WIRE BRUSHES, FILES OR OTHER STEEL TOOLS, SINCE THESE CAN MAR THE STAINLESS STEEL. THESE PARTICLES WILL EVENTUALLY RUST AND STAIN THE SURFACE, AND YOU MAY HAVE TO REFINISH IT.

HOW TO CLEAN STAINLESS STEEL
(CONT.)

SLIGHTLY DARKENED AREAS SOMETIMES APPEAR ON STAINLESS STEEL SURFACES WHERE HEAT HAS BEEN APPLIED DURING FABRICATION OR IN SERVICE.

THESE ARE CAUSED BY THICKENING OF THE PROTECTIVE SURFACE OF STAINLESS STEEL, AND ARE NOT HARMFUL. REMOVAL CALLS FOR ENERGETIC SCOURING, AGAIN USING A STAINLESS STEEL WOOL OR SCOURING PAD, COMBINED WITH A SCOURING POWDER OR ONE OF THE HEAT-TINT REMOVERS LISTED IN THE TABLE.

THREE RULES WILL PREVENT HEAT TINTING:

- 1) USE ONLY ENOUGH HEAT TO DO THE JOB EFFICIENTLY.
- 2) DO NOT APPLY HEAT TO EMPTY EQUIPMENT.
- 3) AVOID CONCENTRATING HEAT ON A SMALL AREA.

***** CAUTION IS ADVISED *****

IN STERILIZING STAINLESS STEEL EQUIPMENT, PAY PARTICULAR ATTENTION TO AGENTS CONTAINING CHLORINE COMPOUNDS SUCH AS POTASSIUM HYPOCHLORITE. THESE COMPOUNDS MAY BREAK DOWN AND RELEASE FREE CHLORINE, OR HYDROLYZE TO FORM HYDROCHLORIC ACID.

STAINLESS STEEL RESISTS ATTACK BY SUCH COMPOUNDS FOR UP TO TWO HOURS. SEVERE LOCALIZED PITTING MAY OCCUR FROM LONGER EXPOSURE. FOR SAFE USE OF THESE AGENTS, KEEP CONTACT TIME SHORT, FLUSH THOROUGHLY WITH WATER, AND OPERATE EQUIPMENT NORMALLY BETWEEN APPLICATIONS. USING THESE PRECAUTIONS, THE STERILIZATION PROCESS CAN BE REPEATED ANY NUMBER OF TIMES.

CLEANERS AND THEIR EFFECT ON STAINLESS STEEL

<u>Cleaning agent</u>	<u>Method of Application</u>	<u>Effect on finish</u>
1. Tightly adhering deposits of "baked on" spatter, oil, grease, weather stain, dyes or other light discoloration may be removed with any of the following cleaners.		
Grade FFF Italian pumice Whiting or bon ami	scour or rub with damp cloth	satisfactory for all finishes use light pressure on no.7
Liquid NuSteel	scour with small amount on dry cloth	satisfactory for all finishes if rubbing pressure is light
Paste NuSteel or Temp	scour with small amount on dry cloth	satisfactory for no. 4 finish. Will scratch no.7
Household cleaners such as Old Dutch, Sunbrite, Wyandotte, Bob-O, Gold Dust and Sapolio	Rub with damp cloth	will scratch no. 4 finish slightly
Grade F Italian Pumice	Rub with damp cloth	will scratch no.4 finish slightly
Cooper's stainless steel polish	Rub with damp cloth	satisfactory for no.4 finish
Allen stainless steel polish	Rub with damp cloth	Scratches considerably but leaves mirror reflection
Best Effect Chemical Co. cleaner & Passivator	Rub with damp cloth	May scratch no.4 finish slightly
2. Heat tint or heavy discoloration with the following (see notes below)		
Allen stainless polish	Small amount on damp cloth remover	excellent heat tint
Birdsall's "Staybright"	Rub with damp cloth	Very good for heat tint removal. Does not scratch no.4 finish but does scratch no.7
Wyandotte or Bob-O	Rub with damp cloth	Good for heat tint removal
Oxalic acid (use warm) Or 15% nitric acid	Swab or immerse. Always follow with a 5% sodium carbonate or neutralizer rinse	Good discoloration remover
Best Effect Chemical Co. cleaner & Passivator	Rub with damp cloth	May scratch no 4 but leaves clean surface

CLEANERS AND THEIR EFFECT ON
STAINLESS STEEL
(Cont.)

Cleaning agent

Effect on finish

3. The following detergents and solvents are excellent removers of grease, oil and fatty acids, where swabbing or rubbing is not practical.

4 to 6% solution of
(sodium Metasilicate)
(Trisodium Phosphate)
(Sodium Metaphosphate)
(Sodium Pyrophosphate)

all excellent
removers of grease,
oil, and milkstone

5-15% caustic soda (hot or cold)

will remove grease
and milkstone

4. The following organic solvents may be used for removing oils and grease deposits:

Carbon-tetrachloride, Naphtha, Trichlorethylene
Acetone, Kerosene, Gasoline, Ether, Alcohol, Benzene

No affect on finish,
however, take all
precautions against
fire.

Notes: ordinary wool or steel brushes should never be used on stainless steel surfaces. Particles of steel may become imbedded in the stainless steel surface, and rusting of these particles will eventually appear as stains. Use stainless steel wool or sponge on stainless steel equipment. Heat tint removers will usually scratch stainless steel surfaces. This, however, is necessary in removing heat tint by hand. Oakite, a fibrous material, may be used in place of metal sponges or cloth pads for applying cleaners and polishes. This material is effective in aiding in removal of milkstone.

For heavy hard water deposits, 15-20% (by volume) nitric acid is very effective. Acid treatment should be followed by a thorough water rinse.

The action of soldering fluxes should be neutralized immediately with a 5% sodium carbonate solution.

Soap and water followed by a water rinse will not harm stainless steel.

PREVENTATIVE MAINTENANCE OF COLORPOINT EQUIPMENT

To insure that your equipment will continue to operate properly, please follow these simple steps:

1. The food receptacle wells should be clean thoroughly every day. Food spillage left in the pans such as tomato paste can cause damage to the unit. The acidic base of foods over time can cause pitting of the units. For more cleaning information on these models, see the section on "HOW TO CLEAN STAINLESS STEEL" in this manual.
2. Always wipe the unit down with a damp cloth. Do not spray water directly in control panel areas or on areas with exposed heating elements.
3. Where applicable, clean sneeze guards daily. See the section on cleaning plexiglass.

LOW TEMP INDUSTRIES
TYPICAL FOLD DOWN BRACKET
USED FOR BOTH TRAY SLIDES
AND CUTTING BOARDS

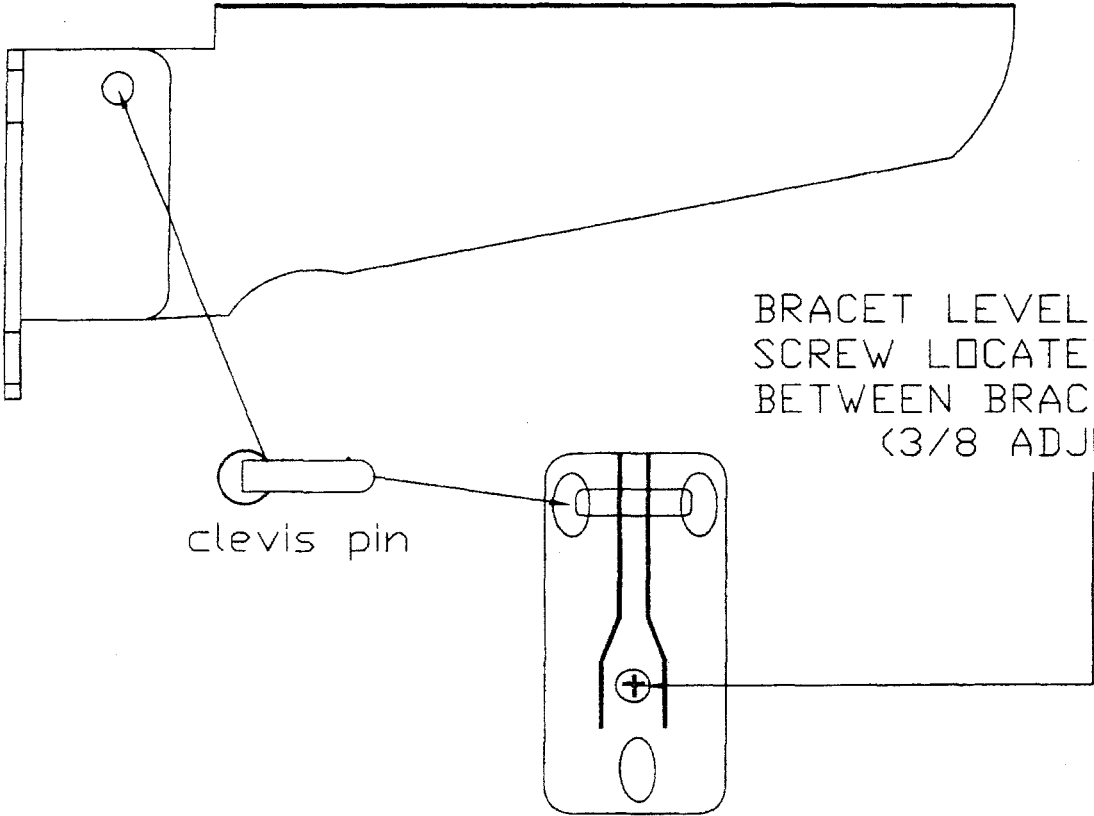

BRACKET LEVEL ADJUSTMENT
SCREW LOCATED ON HEAL PLATE
BETWEEN BRACKET SUPPORTS.
(3/8 ADJUSTMENT)

clevis pin

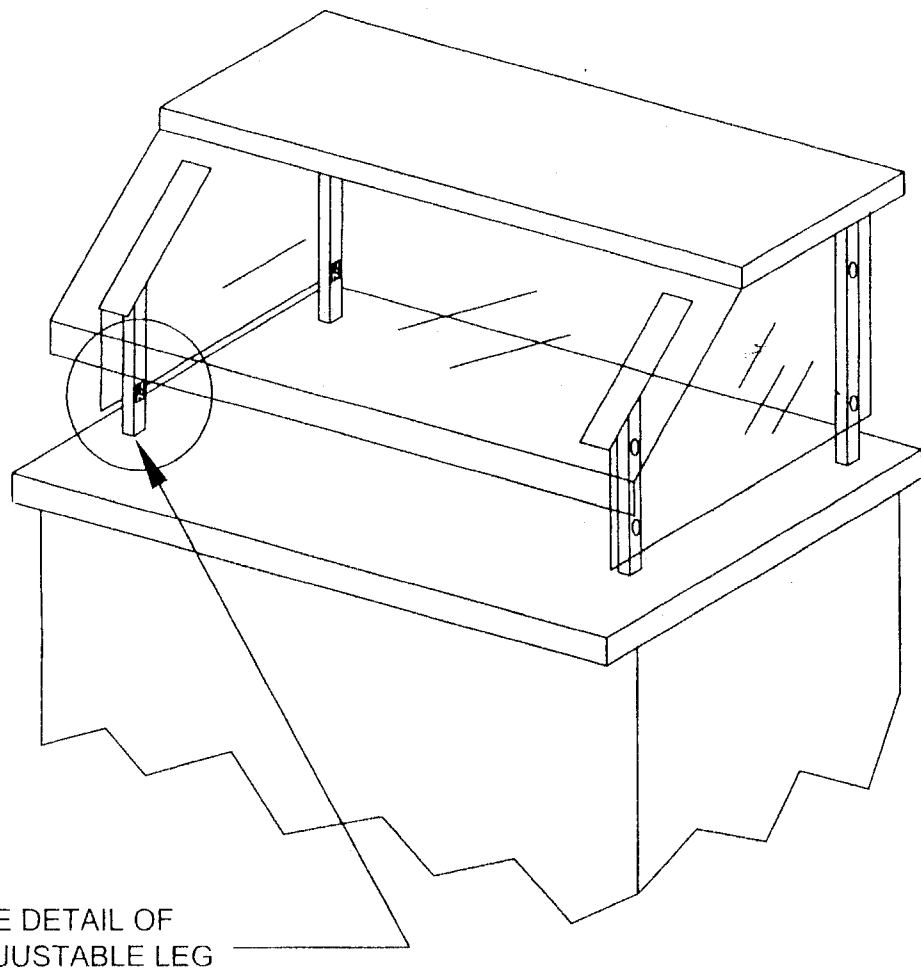

SEE DETAIL OF
ADJUSTABLE LEG

ADJUSTABLE BUFFET FOOD PROTECTOR

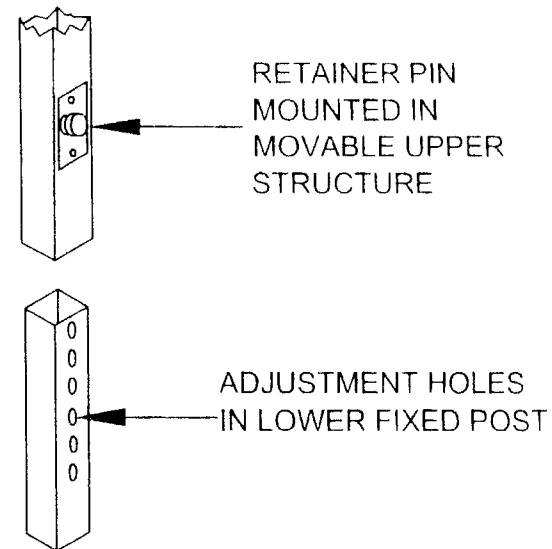

ADJUSTABLE LEG DETAIL

ADJUSTABLE BUFFET SHIELD INSTRUCTIONS

THIS UNIT IS PROVIDED WITH AN ADJUSTABLE BUFFET SHIELD. THE TOTAL ADJUSTMENT IS SIX (6) INCHES FROM ITS LOWEST POSITION IN ONE (1) INCH INCREMENTS.

TO ADJUST THE SHIELD PULL THE RETAINER PIN LOCATED ON EACH POST OUT. THE PIN WILL REMAIN IN THE OUT POSITION BY ROTATING IT ONE QUARTER (1/4) TURN. RAISE THE SHIELD TO THE DESIRED HEIGHT AND TURN RETAINER BACK TO ITS ORIGINAL POSITION.

NOTE! WHEN RAISING THE SHIELD BOTH ENDS MUST BE LIFTED AT THE SAME TIME. DO NOT FORCE THE POST OR PUT THE SYSTEM IN A BIND.

IF ELECTRICAL DEVICES ARE PROVIDED ON THE SHIELD, LOOSEN THE LOCKING COLLAR ON THE WIRE CHASE POST WHICH IS LOCATED BETWEEN THE MAIN SUPPORT POST AND SET IT FLUSH WITH THE COUNTER TOP.

COLORPOINT

5-02

BY LOW TEMP INDUSTRIES
JONESBORO, GEORGIA

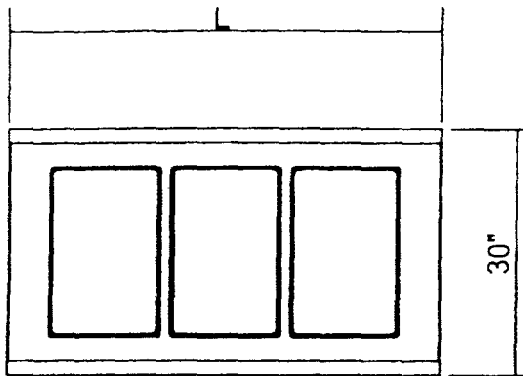

TOP VIEW

5E SERIES HOT FOOD TABLE

THIS DESIGN MAINTAINS ITS COMPARTMENT TEMPERATURE WITH RESISTANCE HEATERS MOUNTED IN EACH WELL OPENING. EACH WELL IS CONTROLLED BY A SEPERATE CAPILARY BULB TYPE THERMOSTAT. THIS SYSTEM MAY BE OPERATED WET OR DRY. THIS SYSTEM CAN BE PROVIDED WITH DRAINS.

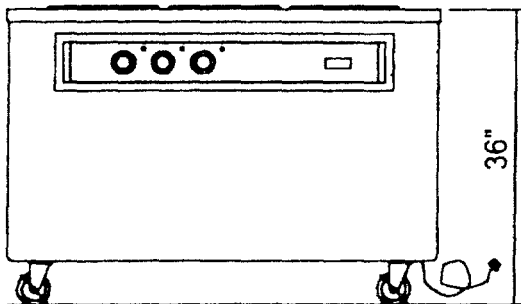

SIDE VIEW

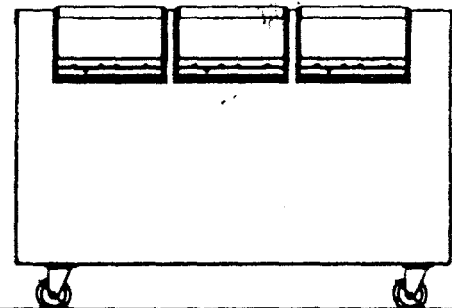

SECTIONAL VIEW

MODEL	L	WELLS	AMPS	VOLTS	PHASE	NEMA PLUG TYPE	SHIPPING WT
5E2-CPA-EB	36"	2	9.6	208	1	6-20P	250
5E3-CPA-EB	50"	3	14.4	208	1	6-30P	300
5E4-CPA-EB	60"	4	19.2	208	1	6-30P	340
5E4-CPA-EB	66"	4	19.2	208	1	6-30P	375
5E5-CPA-EB	74"	5	24.0	208	1	6-30P	435
5E6-CPA-EB	96"	6	28.8	208	1	6-50P	545

TOP: 14 GAUGE STAINLESS STEEL WITH SQUARE TURN DOWNS ON ALL SIDES AND CORNERS FULLY WELDED AND GROUND AND POLISHED TO A #4 SATIN FINISH WITH ALL EDGES HAVING A #7 HI-LITE FINISH.

BODY: SEAMLESS MOLDED FIBERGLASS (F.R.P.) WITH SMOOTH EXTERIOR SURFACE AND ROUNDED CORNERS. ALL FIBERGLASS TO BE FLAME RETARDANT PER SPECIFICATIONS ASTM-E-162 HAVING A FLAME SPREAD OF 25 OR LESS.

DRY/MOIST HOT FOOD WELLS: TO BE BOTTOM MOUNTED AND THE OPENING SHALL BE DIE STAMPED WITH A 1/4" RAISED BEADED EDGE. ALL FOOD WELLS TO BE CENTERED ON THE TOP. EACH WELL SHALL BE SUPPLIED WITH A TUBULAR TYPE RESISTIVE HEATING ELEMENT MOUNTED BELOW THE STAINLESS STEEL WELL AND BE CONTROLLED BY INDIVIDUAL CAPILARY TYPE THERMOSTAT. MAIN POWER IS WIRED THROUGH A CIRCUIT BREAKER FOR CURRENT OVERLOAD PROTECTION.

CASTERS: 4" DIAMETER BALL BEARING, SWIVEL TYPE, NON MARKING WITH BRAKES ON ALL WHEELS. CASTERS TO BE MOUNTED WITH INTERNAL AND EXTERNAL BRACING FOR MAXIMUM STRESS RELIEF.

APPROVALS: THIS UNIT IS LISTED BY UNDERWRITERS LABORATORIES FOR SAFETY AND CLASSIFIED BY UNDERWRITERS LABORATORIES BY SANITATION UNDER NSF STD.4 AND SHALL BEAR BOTH SEALS.

COLORPOINT

5-02

BY LOW TEMP INDUSTRIES
JONESBORO, GEORGIA

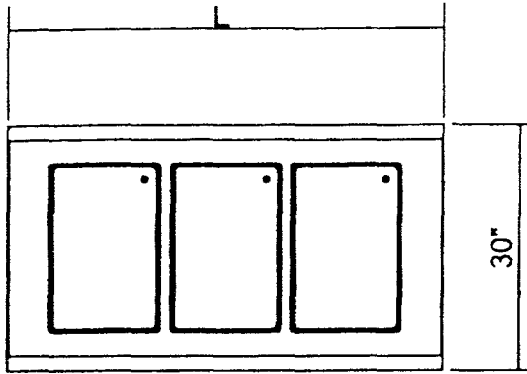

TOP VIEW

5E SERIES HOT FOOD TABLE

THIS DESIGN MAINTAINS ITS COMPARTMENT TEMPERATURE WITH RESISTANCE HEATERS MOUNTED IN EACH WELL OPENING. EACH WELL IS CONTROLLED BY A SEPERATE CAPILARY BULB TYPE THERMOSTAT. THIS SYSTEM MAY BE OPERATED WET OR DRY. THIS SYSTEM CAN BE PROVIDED WITH DRAINS.

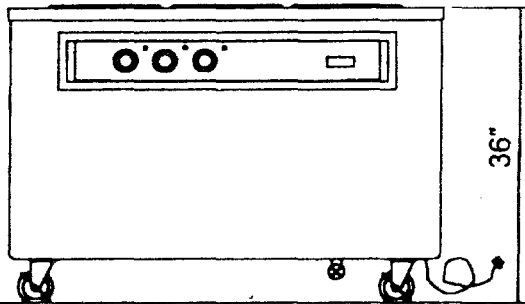

SIDE VIEW

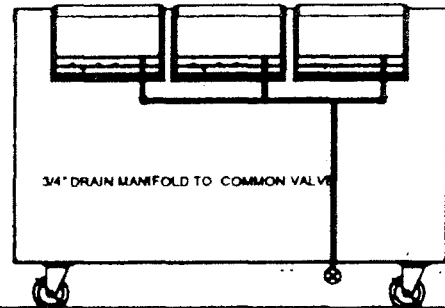

SECTIONAL VIEW

MODEL	L	WELLS	AMPS	VOLTS	PHASE	NEMA PLUG TYPE	SHIPPING WT
5E2-CPA-EB	36"	2	9.6	208	1	6-20P	250
5E3-CPA-EB	50"	3	14.4	208	1	6-30P	300
5E4-CPA-EB	60"	4	19.2	208	1	6-30P	340
5E4-CPA-EB	66"	4	19.2	208	1	6-30P	375
5E5-CPA-EB	74"	5	24.0	208	1	6-30P	435
5E6-CPA-EB	96"	6	28.8	208	1	6-50P	545

TOP: 14 GAUGE STAINLESS STEEL WITH SQUARE TURN DOWNS ON ALL SIDES AND CORNERS FULLY WELDED AND GROUND AND POLISHED TO A #4 SATIN FINISH WITH ALL EDGES HAVING A #7 HI-LITE FINISH.

BODY: SEAMLESS MOLDED FIBERGLASS (F.R.P.) WITH SMOOTH EXTERIOR SURFACE AND ROUNDED CORNERS. ALL FIBERGLASS TO BE FLAME RETARDANT PER SPECIFICATIONS ASTM-E-162 HAVING A FLAME SPREAD OF 25 OR LESS.

DRY/MOIST HOT FOOD WELLS: TO BE BOTTOM MOUNTED AND THE OPENING SHALL BE DIE STAMPED WITH A 1/4" RAISED BEADED EDGE. ALL FOOD WELLS TO BE CENTERED ON THE TOP. EACH WELL SHALL BE SUPPLIED WITH A TUBULAR TYPE RESISTIVE HEATING ELEMENT MOUNTED BELOW THE STAINLESS STEEL WELL AND BE CONTROLLED BY INDIVIDUAL A CAPILARY TYPE THERMOSTAT. MAIN POWER IS WIRED THROUGH A CIRCUIT BREAKER FOR CURRENT OVERLOAD PROTECTION.

CASTERS: 4" DIAMETER BALL BEARING, SWIVEL TYPE, NON MARKING WITH BRAKES ON ALL WHEELS. CASTERS TO BE MOUNTED WITH INTERNAL AND EXTERNAL BRACING FOR MAXIMUM STRESS RELIEF.

APPROVALS: THIS UNIT IS LISTED BY UNDERWRITERS LABORATORIES FOR SAFETY AND CLASSIFIED BY UNDERWRITERS LABORATORIES BY SANITION UNDER NSF STD.4 AND SHALL BEAR BOTH SEALS

TROUBLE SHOOTING SERVICE CHART

SERVICE TO BE PERFORMED BY QUALIFIED SERVICE TECHNICIAN ONLY.

<u>COMPLAINT</u>	<u>PROBLEM</u>	<u>SOLUTION</u>
TABLE WILL NOT HEAT	1. PLUG DISCONNECTED	1. CHECK ALL ELECTRICAL CONNECTIONS.
	2. LINE SWITCH OPEN	2. CLOSE SWITCH
	3. BREAKER TRIPPED	3. RESET BREAKER
	4. HEATER ELEMENT BURNED OUT OR DEFECTIVE	4. REPLACE
	5. THERMOSTAT DEFECTIVE	5. REPLACE
TABLE DOES NOT HEAT	1. LOW VOLTAGE	1. USING INSTRUMENT CHECK LINE VOLTAGE AND AMPERAGE. VOLTAGE MUST BE WITHIN 10 % OF NAME PLATE RATING.
	2. THERMOSTAT CALIBRATION NOT CORRECT	2. RECALIBRATE AS PER INSTRUCTIONS IN THIS MANUAL.

HOT FOOD WELL HEATING ELEMENT DATA

<u>VOLTAGE</u>	<u>WATTAGE</u>	<u>OHMS</u>	<u>AMPERAGE</u>
120	500	28.5	4.2
120	850	17.0	7.1
120	1000	14.4	8.3
208	500	86.6	2.4
208	850	50.7	4.1
*208	*1000	*43.3	*4.8
240	500	114.2	2.1
240	850	66.7	3.6
240	1000	58.5	4.1

* STANDARD HEATING ELEMENT FOR COLORPOINT EQUIPMENT. OTHER ELEMENTS AVAILABLE UPON REQUEST.

FOIL TYPE HEATING ELEMENT FOR HEATED BASE

DOUBLE HEATED BASE

STANDARD ELECTRICAL 208V/ 500W/ 2.4A

SINGLE HEATED BASE

STANDARD ELECTRICAL 208V/ 500W/ 2.4A

REPLACEMENT PARTS LIST
MODEL 5E2-CPA THRU 5E6-CPA

ITEM NO.	DESCRIPTION	STOCK NO.	MFG. NO.	MANUFACTURER
1	HOT FOOD UNIT (1000W/208V COMPLETE UNIT WITH HEATING ELEMENT AND T-STAT READY TO INSTALL.)	LT-1008	LT-1008	LOW TEMP
1A	HOT FOOD UNIT W/ DRAIN (1000W/208V COMPLETE UNIT WITH HEATING ELEMENT AND T-STAT READY TO INSTALL. STANDARD DRAIN 3/4" FPT)	LT-1008D	LT-1008D	LOW TEMP
2	HEATING ELEMENT 1000W/208V	195000	319871242007	CHROMALOX
3	THERMOSTAT	195400	KA-601-72	ROBERTSHAW
4	PILOT LIGHT	358000	515-5CL	JEMCO

NOTE! FOR PART NUMBERS ON HOT FOOD WELLS OTHER THAN THOSE LISTED ABOVE CONTACT THE FACTORY.

5	CASTERS 4" W/ BRAKES	130810	2-4056-43	JARVIS AND JARVIS
6	CIRCUIT BREAKERS			
	1 POLE 15 AMP	332100	QOU-115	SQUARE "D"
	1 POLE 20 AMP	332110	QOU-120	SQUARE "D"
	1 POLE 30 AMP	332120	QOU-130	SQUARE "D"
	2 POLE 15 AMP	332200	QOU-215	SQUARE "D"
	2 POLE 20 AMP	332210	QOU-220	SQUARE "D"
	2 POLE 30 AMP	332220	QOU-230	SQUARE "D"
	2 POLE 40 AMP	332230	QOU-240	SQUARE "D"
	3 POLE 15 AMP	332300	QOU-315	SQUARE "D"
	3 POLE 20 AMP	332310	QOU-320	SQUARE "D"
	3 POLE 30 AMP	332320	QOU-330	SQUARE "D"

CHECK YOUR UNIT FOR SPECIFIC CIRCUIT BREAKER NEEDED.

ADDITIONAL OPTIONS AVAILABLE

7	SWITCH SINGLE POLE (BALL BAT LIGHT SWITCH)	335900	90-0001	McGILL
8	SWITCH DOUBLE POLE (BALL BAT HEAT LAMP SWITCH)	335920	0121-0001	McGILL
9	TUNGSTEN SWITCH (PADDLE SWITCH USED WITH BULLET TYPE HEAT LAMPS)	335911	TA115PWBXGC1	CARLING
10	FLUORESCENT FIXTURE	360700	M15L	NULITE
11	FLUORESCENT BULB	358100	F15T8/CW	SYLVANIA
12	BULB SLEEVE & CAP	493510	18" T8	TRU-TEST

REPLACEMENT PARTS LIST
MODEL 5E2-CPA THRU 5E6-CPA
ADDITIONAL OPTIONS
(CONT.)

ITEM NO.	DESCRIPTION	STOCK NO.	MFG. NO.	MANUFACTURER	
13	SINGLE PORCELAIN SOCKET (USED WITH BULLET TYPE HEAT LAMP OR INCANDESCENT BULBS NOT IN HEAT LAMPS)	360610	10035-000	LEVITON	
14	DOUBLE PORCELAIN SOCKET (USED WITH INCANDESCENT BULB NOT IN HEAT LAMPS)	533800	4010	LEVITON	
15	BULLET HEAT LAMPS (250 W / 120 V / CLEAR WITH TOUGH SKIN COATING)	357800	250R40/1CVG	GENERAL ELECTRIC	
16	INCANDESCENT BULBS (40 W / 120 V / APPLIANCE BULBS WITH TOUGH SKIN COATING)	494300	R79-0040	COMPONENT HARDWARE	
17	FUSE HOLDER	358210	571027	LITTLE FUSE	
18	STOCK	1A	513800	SLC-1 CLASS G	LITTLE FUSE
	FUSES	2A	513810	SLC-2 CLASS G	LITTLE FUSE
		4A	513820	SLC-4 CLASS G	LITTLE FUSE
		5A	513830	SLC-5 CLASS G	LITTLE FUSE
		6A	513840	SLC-6 CLASS G	LITTLE FUSE
		8A	513850	SLC-8 CLASS G	LITTLE FUSE
		10A	513860	SLC-10 CLASS G	LITTLE FUSE
		15A	513870	SLC-15 CLASS G	LITTLE FUSE
		20A	513880	SLC-20 CLASS G	LITTLE FUSE

NOTE! REPLACE WITH SAME TYPE AND AMPERAGE FUSE. CHECK YOUR UNIT FOR THE SPECIFIC FUSE USED.

19	INFINITE CONTROL (USED WITH HEATED BASE)	190600	INF-240-3	E.G.O.
20	THERMOMETER (USED WITH HEATED BASE)	500040	2215-01-4	COOPER

FOR REPLACEMENT HEATING SYSTEMS FOR HEATED BASES, SPECIFY SINGLE OR DOUBLE BASE. STANDARD VOLTAGE IS 208V.

FOR PARTS CONCERNING CALROD TYPE HEAT LAMPS STRIPS SUPPLIED WITH THIS SYSTEM CONTACT YOUR FACTORY REPRESENTATIVE.

SPECIFIC PLUG WILL VARY DEPENDING UPON OPTIONS PURCHASED. CONSULT FACTORY FOR SPECIFIC PLUG AND POWER REQUIREMENTS

THREE (3) HOT FOOD UNIT SHOWN. MAY BE PROVIDED WITH ONE (1) TO SIX (6) UNITS. STANDARD ELECTRICAL SPECIFICATION IS 208V/1000W EA OTHER VOLTAGE AND WATTAGES AVAILABLE. CONSULT FACTORY FOR SPECIFICS.

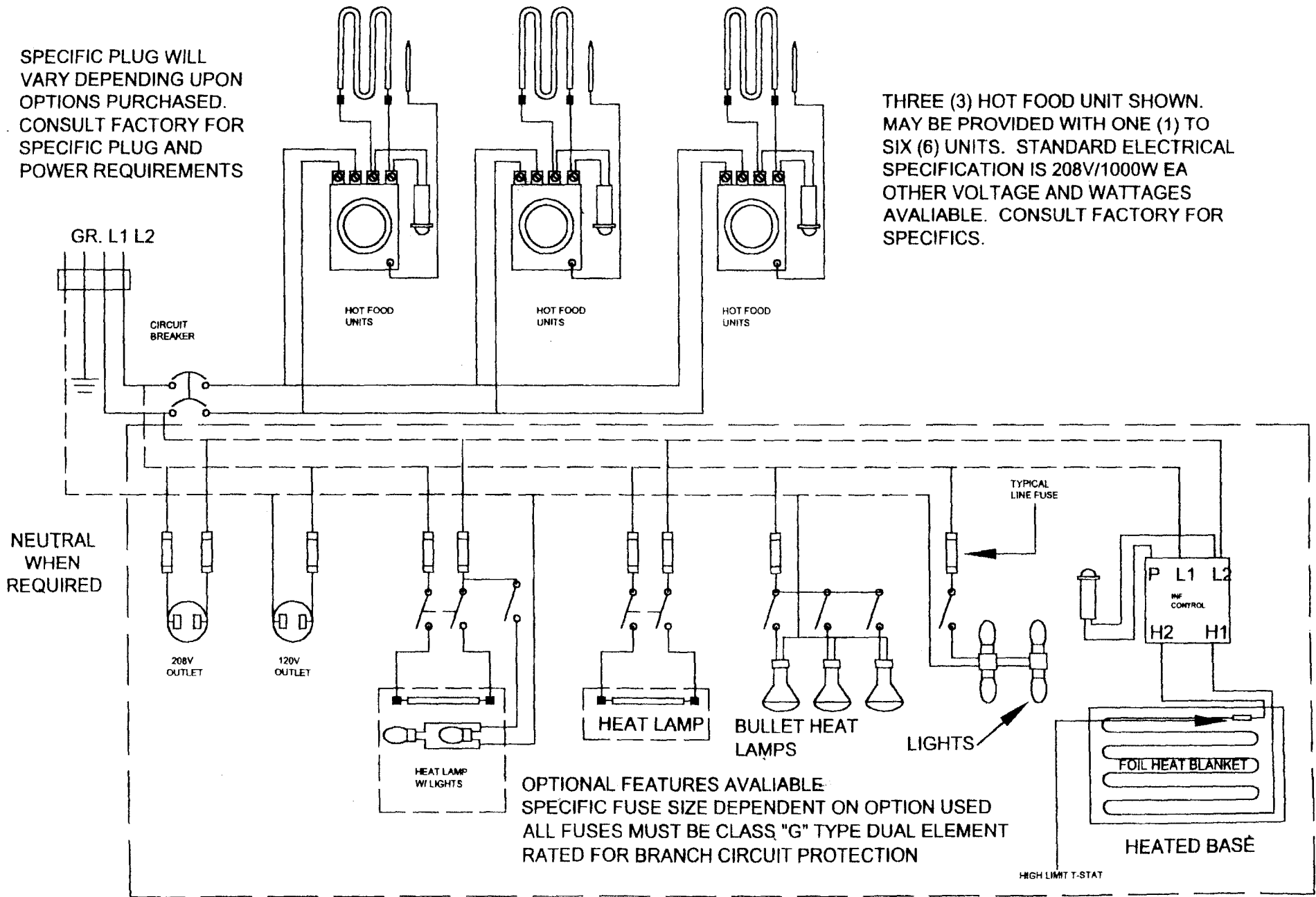

OPTIONAL FEATURES AVAILABLE:
 SPECIFIC FUSE SIZE DEPENDENT ON OPTION USED
 ALL FUSES MUST BE CLASS "G" TYPE DUAL ELEMENT
 RATED FOR BRANCH CIRCUIT PROTECTION

SPECIFIC PLUG WILL VARY DEPENDING UPON OPTIONS PURCHASED. CONSULT FACTORY FOR SPECIFIC PLUG AND POWER REQUIREMENTS

NOTE! IF 190V HIGH LEG EXIST WIRE TO L2 ONLY. ALL 120V CIRCUITS WIRED TO L1 OR L3.

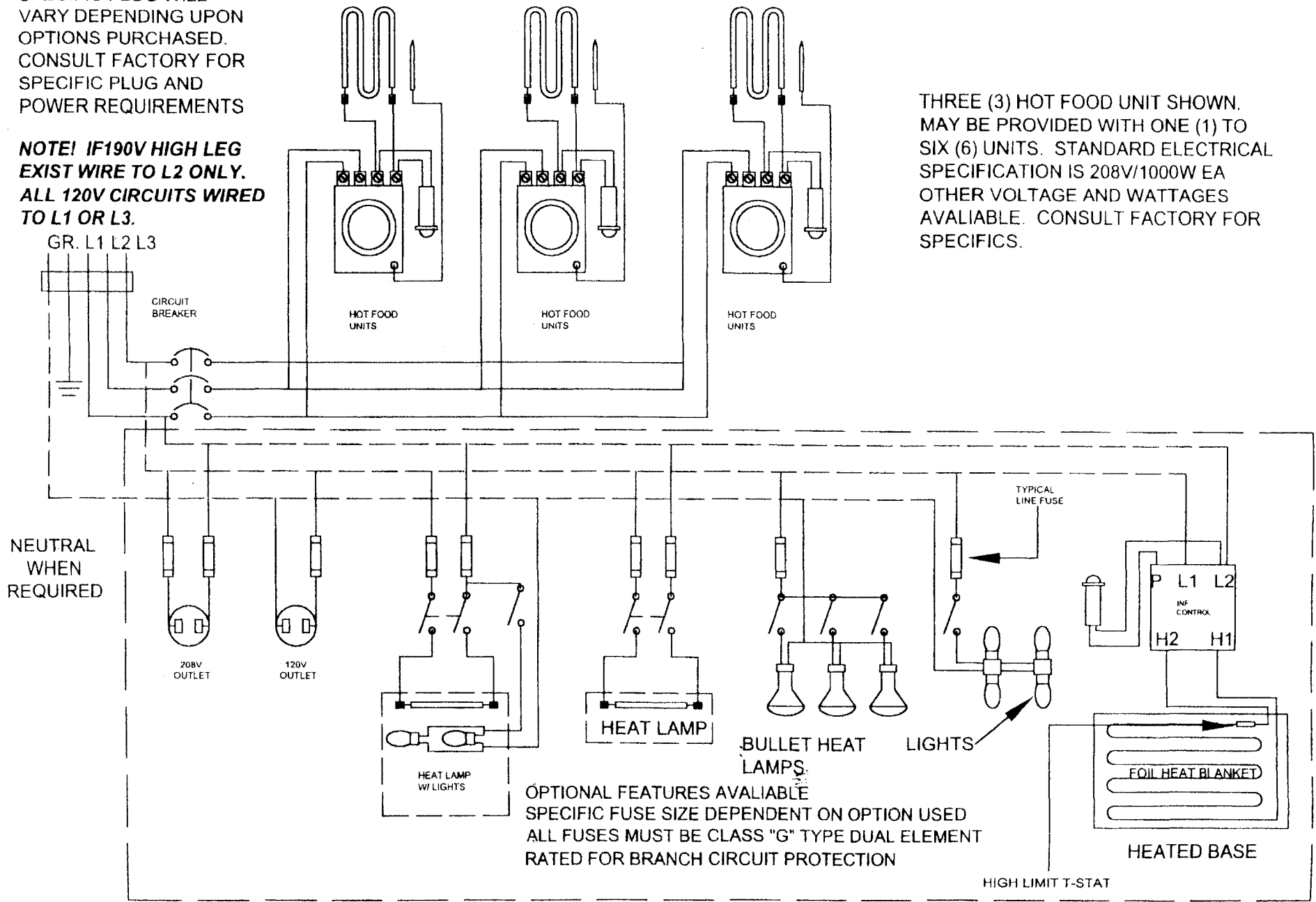

THREE (3) HOT FOOD UNIT SHOWN. MAY BE PROVIDED WITH ONE (1) TO SIX (6) UNITS. STANDARD ELECTRICAL SPECIFICATION IS 208V/1000W EA OTHER VOLTAGE AND WATTAGES AVAILABLE. CONSULT FACTORY FOR SPECIFICS.

DRY/MOIST HOT FOOD UNIT EXPLODED VIEW

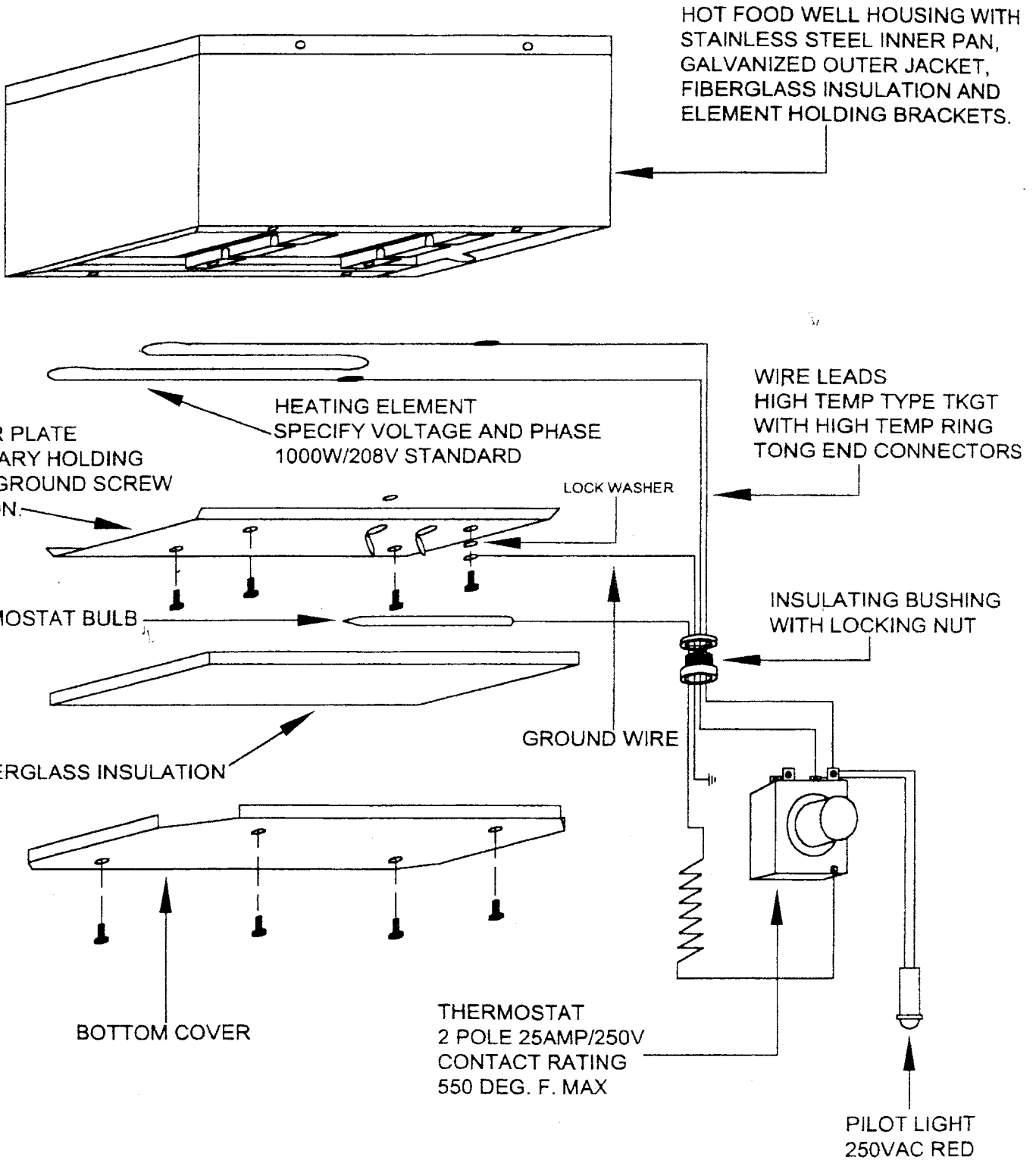

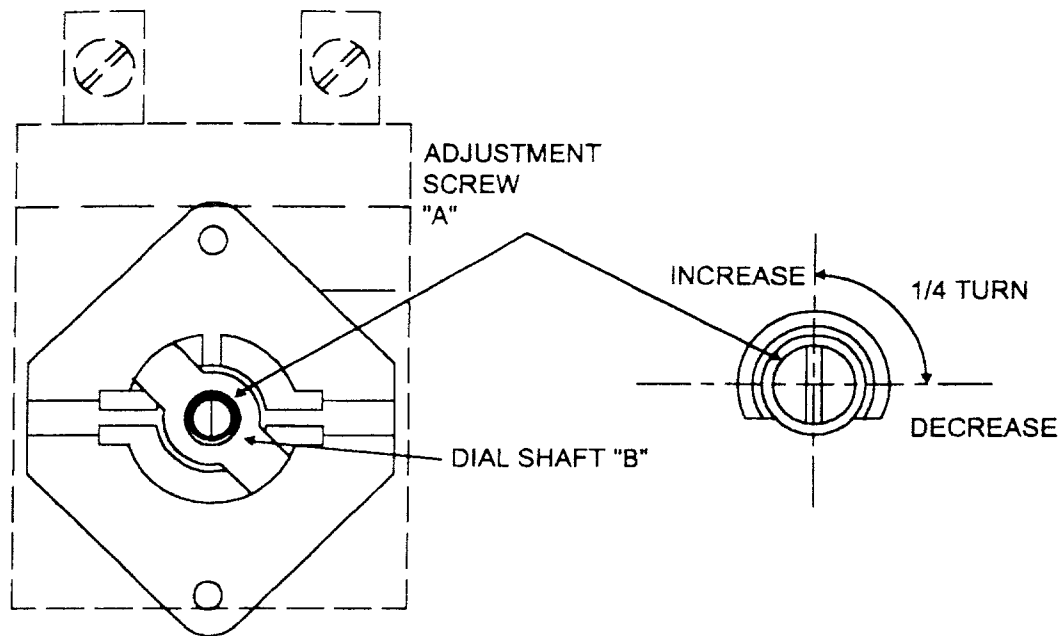

LOW TEMP INDUSTRIES CHECKING THERMOSTAT CALIBRATION

EACH THERMOSTAT IS ADJUSTED AT THE FACTORY AND CALIBRATED ON A PRECISION INSTRUMENT TO CONTROL TEMPERATURE ACCURATELY. ADJUSTMENT OR RECALIBRATION IS NOT NEEDED UNLESS THE THERMOSTAT HAS BEEN MISHANDLED IN TRANSIT OR CHANGED OR OTHERWISE ABUSED.

TO CHECK CALIBRATION

1. USE A POTENTIOMETER OR A GOOD GRADE THERMOMETER TO DETERMINE TEMPERATURE AT LOCATION WHERE TEMPERATURE REGULATION IS REQUIRED.
2. TURN THE DIAL OF THE THERMOSTAT TO A MEDIUM TEMPERATURE SETTING.
3. ALLOW ENOUGH TIME FOR TEMPERATURE TO STABILIZE, OR UNTIL SEVERAL TEMPERATURE READINGS ARE IDENTICAL.

TO RECALIBRATE

1. REMOVE DIAL FROM SHAFT "B"
2. WHILE HOLDING SHAFT "B" TURN THE ADJUSTMENT SCREW "A" CLOCKWISE TO DECREASE OR COUNTER CLOCKWISE TO INCREASE. IT'S RECOMMENDED THAT ADJUSTMENTS BE NO MORE THAN 1/4 TURN AT A TIME.
3. REPLACE DIAL
4. AFTER A CALIBRATION CHANGE HAS BEEN MADE LET THE UNIT OPERATE UNTIL THE TEMPERATURE HAS STABILIZED, THEN RECHECK TO DETERMINE WHETHER OR NOT THE CALIBRATION HAS BEEN CORRECTED.

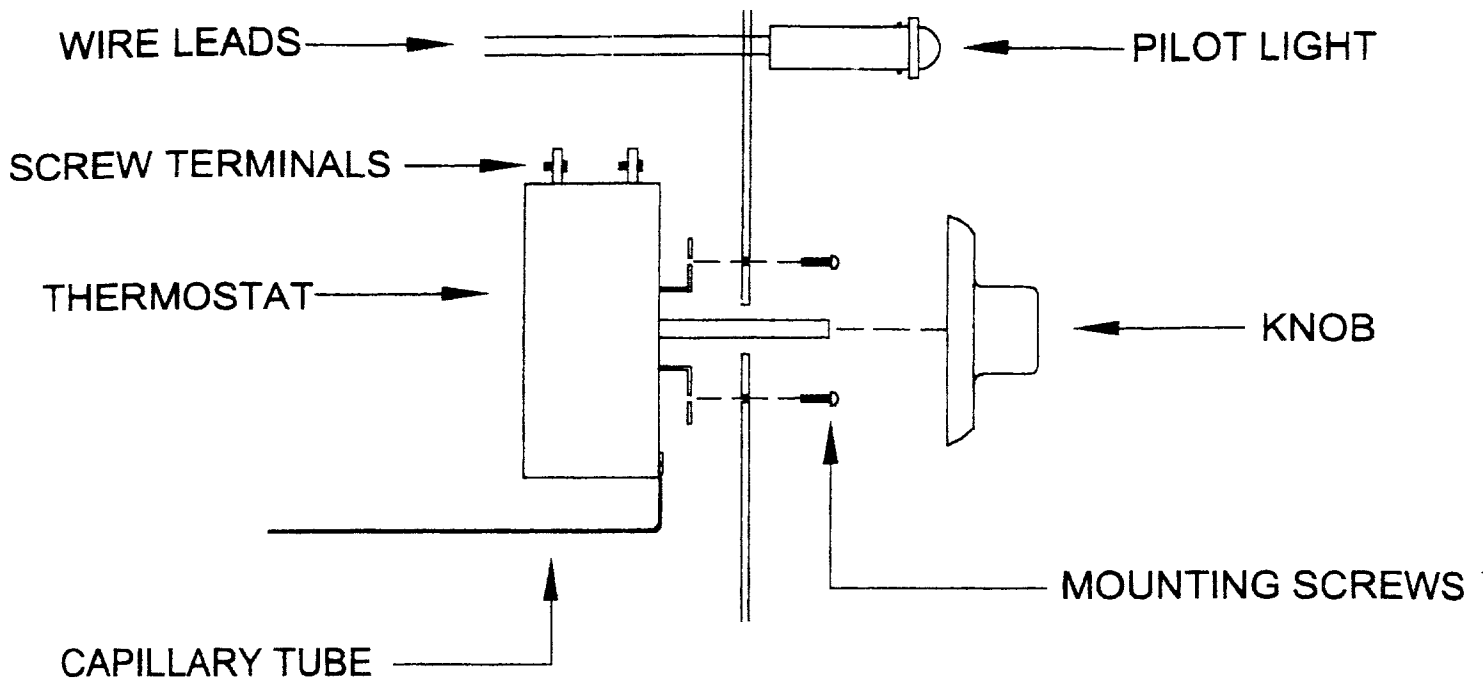

THERMOSTAT & PILOT LIGHT MOUNTING

To remove Thermostat

- (1) Disconnect electrical power
- (2) Remove thermostat mounting panel by removing screws and pulling panel forward.
- (3) Remove wire leads from thermostat screw terminals
- (4) Pull knob off and remove the two mounting screws on the front of the thermostat.
- (5) Remove the bottom cover plate from the hot food well
- (6) remove the capillary bulb from the deflector plate

To replace the thermostat reverse the above procedure

To remove the pilot light

- (1) Disconnect electrical power
- (2) Remove the thermostat mounting panel by removing screws and pulling panel forward.
- (3) Remove the wire leads from thermostat screw terminals
- (4) Press in on detents on back of pilot light.
- (5) Pull pilot light forward.

To replace the pilot light reverse the above procedure

HEATING ELEMENT REPLACEMENT

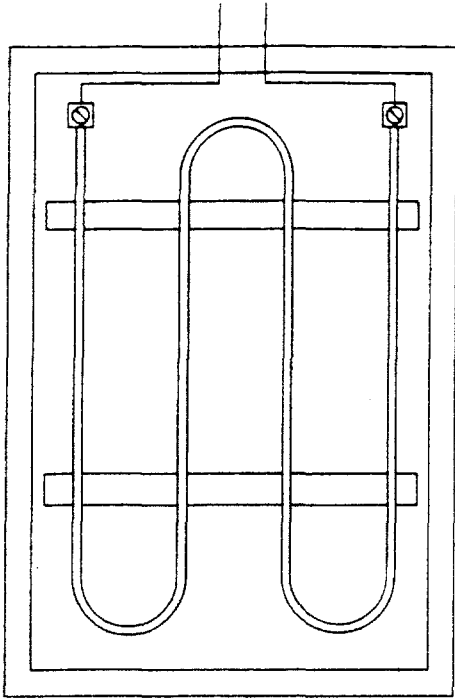

1. REMOVE POWER FROM UNIT
2. REMOVE THE BOTTOM COVER AND INSULATION FROM UNIT.
3. REMOVE THE BOTTOM DEFLECTOR PLATE. NOTE THE THERMOSTAT CAPILLARY MOUNTED TO THE DEFLECTOR PLATE.
4. REMOVE THE OLD HEATER FROM THE HOLDING BRACKETS.
5. REMOVE THE WIRE LEADS FROM TERMINALS.
6. REINSTALL WIRE LEADS TO NEW HEATER.
7. PLACE THE NEW ELEMENT INTO THE HOLDING BRACKETS.
8. REPLACE DEFLECTOR PLATE INSULATION AND BOTTOM COVER.

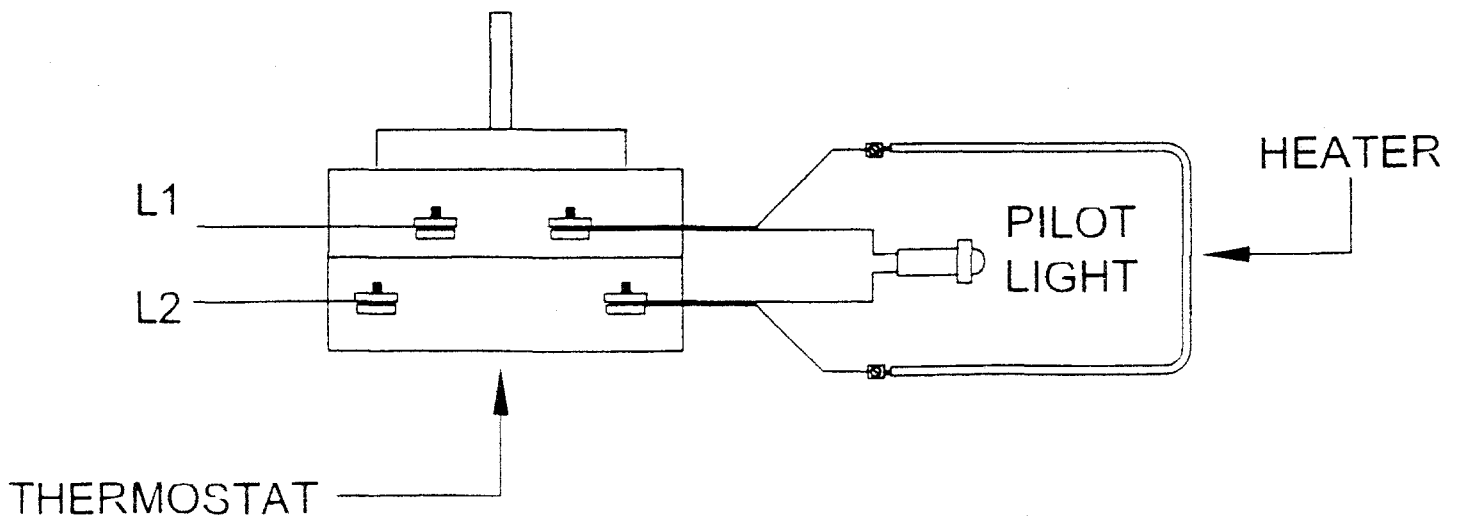

LOW TEMP INDUSTRIES
HEATED BASE
STANDARD ELECTRICAL 208V/440W/1PH

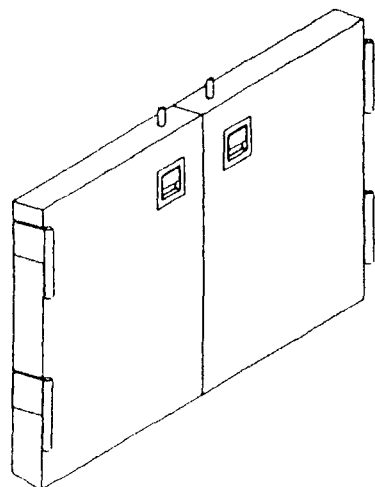

INSULATED HINGED DOORS
WITH PADDLE LATCH AND
LIFT-OFF HINGES

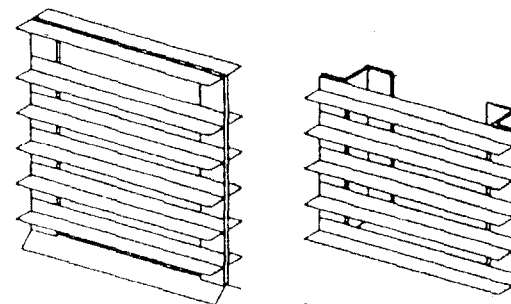

CENTER MOUNT

SIDE MOUNT

RACK SLIDES ON 2-1/2" CENTERS
TWO (2) SIDE MOUNT WITH KEY
HOLE SLOTS AND ONE (1) CENTER
SLIDE IN MOUNT.

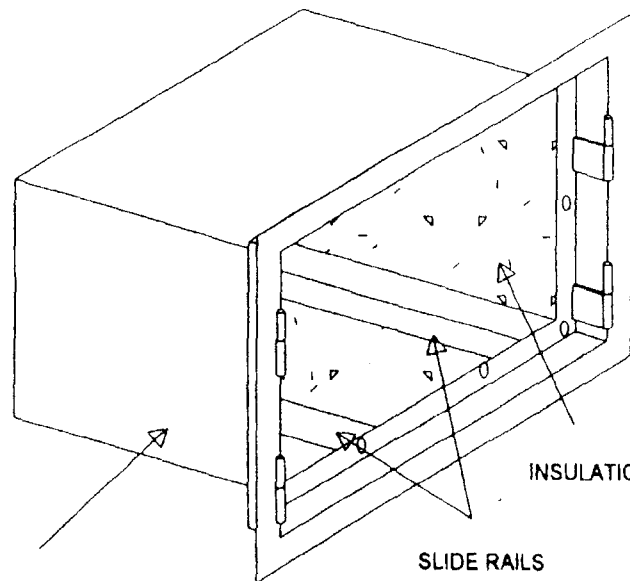

INSULATED JACKET
MOUNTED TO BASE

INSULATION

SLIDE RAILS

WIRE LEADS

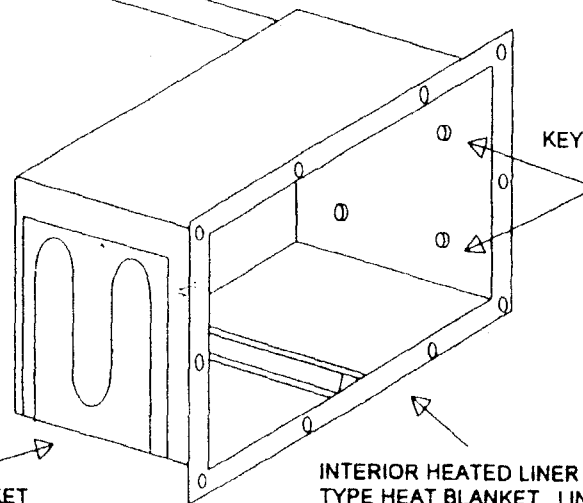

KEY HOLE STUDS

HEAT BLANKET

INTERIOR HEATED LINER WITH FOIL
TYPE HEAT BLANKET. LINER IS MOUNTED
INTO THE INSULATED JACKET AND SECURED
WITH SCREWS AROUND PERIMETER FLANGE.

ONE YEAR WARRANTY

ALL COLORPOINT FOOD SERVICE EQUIPMENT IS FULLY WARRANTED BY THE MANUFACTURER AGAINST DEFECTS IN MATERIALS OR WORKMANSHIP FOR A PERIOD OF ONE (1) YEAR FROM THE DATE OF PURCHASE BY THE ORIGINAL USER AND ONLY TO THE ORIGINAL PURCHASER PROVIDED IT IS INSTALLED AND OPERATED IN ACCORDANCE WITH THE INSTRUCTIONS SUPPLIED WITH THE UNIT. ALSO, IT MUST NOT BE MISUSED, ALTERED OR NEGLECTED AND USED ONLY ON CIRCUITS AND VOLTAGES REQUIRED FOR THAT UNIT.

OUR OBLIGATION UNDER THIS WARRANTY SHALL BE LIMITED TO ONE OF THE FOLLOWING PROCEDURES. SELECTION OF A PROCEDURE SHALL BE AT THE SOLE DISCRETION OF LOW TEMP INDUSTRIES INC.

LOW TEMP INDUSTRIES, INC. WARRANTY SERVICE DEPARTMENT MUST BE NOTIFIED PRIOR TO ANY SERVICE WORK FOR A WARRANTY AUTHORIZATION NUMBER. ANY REQUESTS FOR WARRANTY CLAIMS WITHOUT A WARRANTY AUTHORIZATION NUMBER, WILL NOT BE HONORED.

- A. REPLACEMENT OF DEFECTIVE PARTS, SHIPPED F.O.B. FACTORY, IN EXCHANGE FOR THE RETURNED DEFECTIVE PART, SHIPPED PREPAID FREIGHT.
- B. FREE REPLACEMENT OF DEFECTIVE PART, SHIPPED F.O.B. FACTORY.
- C. DEFECTIVE PART SHIPPED PREPAID FREIGHT TO FACTORY, REPAIRED AND RETURNED, SHIPPED F.O.B. . FACTORY.
- D. ALL LABOR COSTS SHALL BE COVERED FOR A PERIOD OF 1 YEAR FROM THE DATE OF PURCHASE.

LOW TEMP INDUSTRIES INC. SHALL NOT BE RESPONSIBLE FOR ANY DAMAGE CAUSED BY FIRE, FLOOD, WINDSTORM, OR ANY OTHER ACT OF GOD; WAR, WHETHER DECLARED OR UNDECLARED NOR SHALL WE BE RESPONSIBLE FOR THE LOSS OF FOOD OR OTHER PRODUCTS DUE TO POWER OR MECHANICAL FAILURE. THIS WARRANTY SHALL NOT COVER ANY DAMAGE CAUSED DURING SHIPMENT WHICH SHOULD BE REPORTED TO THE DELIVERING CARRIER.

COLORPOINT FIBERGLASS FOOD SERVICE EQUIPMENT

A DIVISION OF LOW TEMP INDUSTRIES INC.
9192 TARA BOULEVARD
JONESBORO, GEORGIA 30236
(770) 478-8803