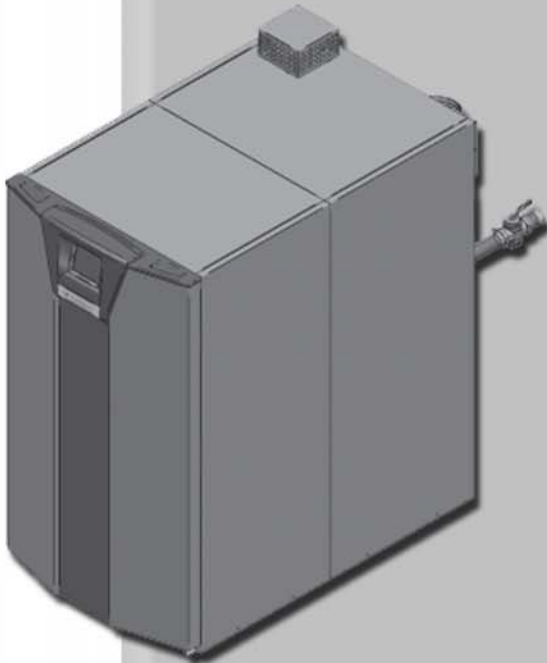


# SYNC™

CONDENSING BOILER

## Installation & Operation Manual

Models: 1.0 - 1.3 - 1.5



**⚠ WARNING** This manual must only be used by a qualified heating installer / service technician. Read all instructions, including this manual and the SYNC Service Manual, before installing. Perform steps in the order given. Failure to comply could result in severe personal injury, death, or substantial property damage.



Save this manual for future reference.

# Contents

<b>HAZARD DEFINITIONS</b> .....	2
<b>PLEASE READ BEFORE PROCEEDING</b> .....	3
<b>THE SYNC -- HOW IT WORKS</b> .....	4-5
<b>RATINGS</b> .....	6
<b>1. DETERMINE BOILER LOCATION</b>	
Closet and Alcove Installations .....	7
Provide Air Openings to Room .....	9
Flooring and Foundation .....	9
Vent and Air Piping .....	9
Prevent Combustion Air Contamination.....	9
Using an Existing Vent System to Install a New Boiler ...	10
Corrosive Contaminants and Sources .....	10
Removing a Boiler from Existing Common Vent.....	11
Remove Boiler from Wood Pallet.....	11
Combustion and Ventilation Air Requirements .....	12-13
<b>2. GENERAL VENTING</b>	
Direct Venting Options - Sdw/Horz. Vent Opt. Rm Air....	14
Direct Venting Options - Vert. Vent Opt. Rm Air.....	15
Direct Venting Options - Vert. Vent, Horz. Air .....	16
Install Vent and Combustion Air Piping .....	17
PVC / CPVC Vent Piping Materials.....	17
PVC/CPVC Air Intake/Vent Connections .....	18
Air Inlet Pipe Materials.....	18
Requirements for Installation in Canada.....	19
Installing Vent and Air Piping .....	19
Stainless Steel Vent and Air Piping .....	20
Min./Max. Combustion Air & Vent Piping Lengths .....	21
Vent and Air Piping .....	21
<b>3. SIDEWALL DIRECT VENTING</b>	
Vent/Air Termination - Sidewall.....	22-25
Determine Location.....	22-24
Prepare Wall Penetrations.....	24
Termination and Fittings .....	25
Multiple Vent/Air Terminations.....	25
<b>4. VERTICAL DIRECT VENTING</b>	
Vent/Air Termination - Vertical .....	26-27
Determine Location.....	26
Prepare Roof Penetrations .....	26
Termination and Fittings .....	26-27
Multiple Vent/Air Terminations.....	27
Room Air .....	27
<b>5. HYDRONIC PIPING</b>	
System Water Piping Methods.....	28
Low Water Cutoff Device .....	28
Chilled Water System.....	28
Freeze Protection.....	28
General Piping Information .....	28
Circulator Sizing .....	29
Near Boiler Piping Connections .....	29
Near Boiler Piping Components.....	31-33
<b>6. GAS CONNECTIONS</b>	
Connecting Gas Supply Piping .....	34
Natural Gas .....	35
Pipe Sizing for Natural Gas .....	35
Natural Gas Supply Pressure Requirements .....	35
Propane Gas .....	35
Pipe Sizing for Propane Gas .....	35
Propane Supply Pressure Requirements .....	35
Check Inlet Gas Supply .....	36-37
Gas Pressure .....	37
Gas Valve Replacement .....	37
<b>7. FIELD WIRING</b>	
Line Voltage Connections .....	38
Low Voltage Connections .....	39
Wiring of the Cascade.....	40
<b>8. CONDENSATE DISPOSAL</b>	
Condensate Drain .....	42
<b>9. STARTUP</b> .....	43-49
<b>10. OPERATING INFORMATION</b>	
General.....	50-51
Cascade .....	52-53
Sequence of Operation .....	54
Status Screen.....	55-56
Main Screen .....	57
<b>11. MAINTENANCE</b>	
Maintenance & Annual Startup.....	58-63
<b>12. DIAGRAMS</b>	
Ladder Diagrams .....	64-65
Wiring Diagram .....	66
Revision Notes .....	Back Cover

## Hazard definitions

The following defined terms are used throughout this manual to bring attention to the presence of hazards of various risk levels or to important information concerning the life of the product.

### **⚠ DANGER**

DANGER indicates an imminently hazardous situation which, if not avoided, will result in death or serious injury.

### **⚠ WARNING**

WARNING indicates a potentially hazardous situation which, if not avoided, could result in death or serious injury.

### **⚠ CAUTION**

CAUTION indicates a potentially hazardous situation which, if not avoided, may result in minor or moderate injury.

### **CAUTION**

CAUTION used without the safety alert symbol indicates a potentially hazardous situation which, if not avoided, may result in property damage.

### **NOTICE**

NOTICE indicates special instructions on installation, operation, or maintenance that are important but not related to personal injury or property damage.

## Please read before proceeding

### ⚠ WARNING

**Installer** – Read all instructions, including this manual and the SYNC Service Manual, before installing. Perform steps in the order given.

**User** – This manual is for use only by a qualified heating installer/service technician. Refer to the User's Information Manual for your reference.

Have this boiler serviced/inspected by a qualified service technician, at least annually.

Failure to comply with the above could result in severe personal injury, death or substantial property damage.

### NOTICE

When calling or writing about the boiler – Please have the boiler model and serial number from the boiler rating plate.

Consider piping and installation when determining boiler location.

Any claims for damage or shortage in shipment must be filed immediately against the transportation company by the consignee.

Factory warranty (shipped with unit) does not apply to units improperly installed or improperly operated.

### ⚠ WARNING

Failure to adhere to the guidelines on this page can result in severe personal injury, death, or substantial property damage.

### ⚠ WARNING

If the information in this manual is not followed exactly, a fire or explosion may result causing property damage, personal injury or loss of life.

This appliance **MUST NOT** be installed in any location where gasoline or flammable vapors are likely to be present.

#### WHAT TO DO IF YOU SMELL GAS

- Do not try to light any appliance.
- Do not touch any electric switch; do not use any phone in your building.
- Immediately call your gas supplier from a near by phone. Follow the gas supplier's instructions.
- If you cannot reach your gas supplier, call the fire department.
- Installation and service must be performed by a qualified installer, service agency, or the gas supplier.

### ⚠ WARNING

DO NOT install units in rooms or environments that contain corrosive contaminants (see Table 1A on page 10). Failure to comply could result in severe personal injury, death, or substantial property damage.

### ⚠ WARNING

The California Safe Drinking Water and Toxic Enforcement Act requires the Governor of California to publish a list of substances known to the State of California to cause cancer, birth defects, or other reproductive harm, and requires businesses to warn of potential exposure to such substances.

This product contains a chemical known to the State of California to cause cancer, birth defects, or other reproductive harm. This boiler can cause low level exposure to some of the substances listed in the Act.

### When servicing boiler –

- To avoid electric shock, disconnect electrical supply before performing maintenance.
- To avoid severe burns, allow boiler to cool before performing maintenance.

### Boiler operation –

- Do not block flow of combustion or ventilation air to the boiler.
- Should overheating occur or gas supply fail to shut off, do not turn off or disconnect electrical supply to circulator. Instead, shut off the gas supply at a location external to the appliance.
- Do not use this boiler if any part has been under water. The possible damage to a flooded appliance can be extensive and present numerous safety hazards. Any appliance that has been under water must be replaced.

### Boiler water –

- Thoroughly flush the system to remove debris. Use an approved pre-commissioning cleaner (see Start-Up Section), without the boiler connected, to clean the system and remove sediment. The high-efficiency heat exchanger can be damaged by build-up or corrosion due to sediment.

**NOTE:** Cleaners are designed for either new systems or pre-existing systems. Choose accordingly.

### Freeze protection fluids –

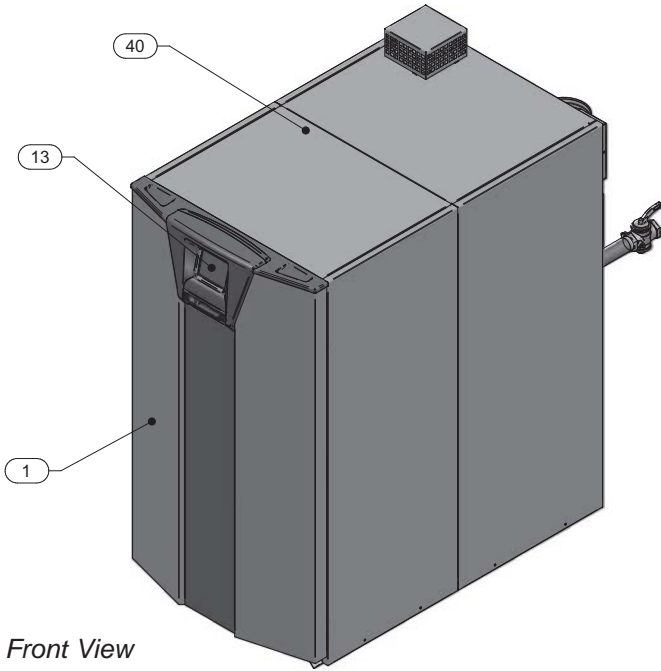
- NEVER use automotive antifreeze. Use only inhibited propylene glycol solutions, which are specifically formulated for hydronic systems. Ethylene glycol is toxic and can attack gaskets and seals used in hydronic systems.

## The SYNC - How it works...

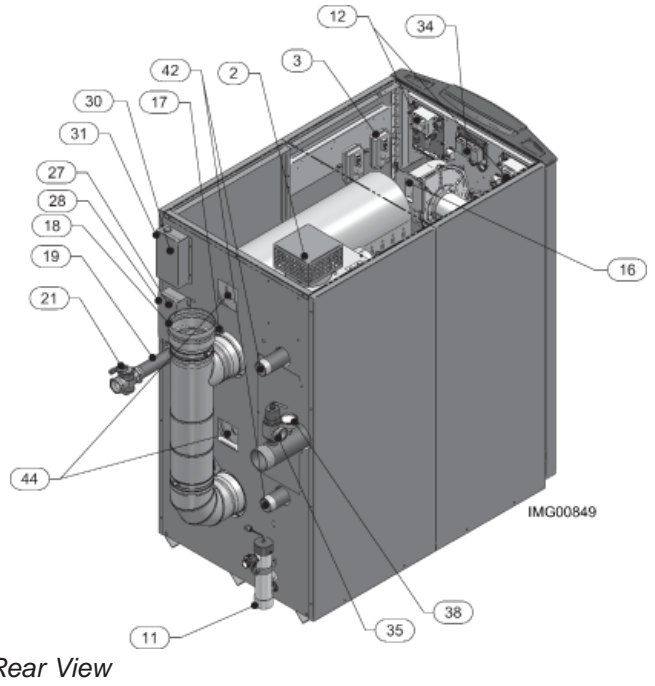
1. **Access cover - front**  
Provides access to the gas train and the heat exchanger.
2. **Air intake adapter**  
Allows for the connection of the PVC air intake pipe to the boiler.
3. **Air pressure switches**  
The air pressure switches detect blocked flue/vent conditions.
4. **Air shrouds (1.0 Model only)**  
The air shrouds control air and gas flow into the burners.
5. **Automatic air vents**  
Designed to remove trapped air from the heat exchanger coils.
6. **Blowers**  
The blowers pull in air and gas through the venturis (item 35). Air and gas mix inside the blowers and are pushed into the burners, where they burn inside the combustion chamber.
7. **Boiler drain port**  
Location from which the heat exchangers can be drained.
8. **Boiler inlet temperature sensors**  
These sensors monitor system return water temperature. If selected as the controlling sensor, the control module adjusts the boiler firing rate so the inlet temperature matches the set point.
9. **Boiler outlet temperature sensors (housed with the high limit sensor)**  
These sensors monitor boiler outlet water temperature. If selected as the controlling sensor, the control module adjusts boiler firing rate so the outlet temperature matches the set point.
10. **Burners (not shown)**  
Made with metal fiber and stainless steel construction, the burners use pre-mixed air and gas and provide a wide range of firing rates.
11. **Condensate drain connection**  
Connects the condensate drain line to a 1/2" PVC union.
12. **Control modules**  
The control modules respond to internal and external signals and control the blowers, gas valves, and pumps to meet the heating demand.
13. **Electronic display**  
Digital controls with touch screen technology and full color display.
14. **Flame inspection windows**  
The quartz glass windows provide a view of the burner surfaces and flames.
15. **Flame sensors**  
Used by the control module to detect the presence of burner flame.
16. **Flap valves**  
Prevents recirculation of flue products when only one burner is running.
17. **Flue gas sensors**  
These sensors monitor the flue gas exit temperature. The control modules will modulate and shut down the boiler if the flue gas temperature gets too hot. This protects the flue pipe from overheating.
18. **Flue pipe adapter**  
Allows for the connection of the PVC vent pipe system to the boiler.
19. **Gas connection pipe**  
Threaded 1 1/2" pipe connection. This pipe should be connected to the incoming gas supply for the purpose of delivering gas to the boiler.
20. **Gas shutoff valves (inside unit)**  
Manual valves used to isolate the gas valves from the burners.
21. **Gas shutoff valve (outside unit)**  
Manual valve used to isolate the gas valve from the gas supply.
22. **Gas valves**  
The gas valves sense the negative pressure created by the blowers, allowing gas to flow only if the gas valves are powered and combustion air is flowing.
23. **Heat exchanger access covers**  
Allows access to the combustion side of the heat exchanger coils.
24. **High gas pressure switches**  
Switches provided to detect excessive gas pressure.
25. **Manual Reset High Limit (MRHL)**  
Device used to monitor the outlet water temperature. If the temperature exceeds its setting, it will break the control circuit, shutting the boiler down.
26. **Ignition electrodes**  
Provides direct spark for igniting the burners.
27. **Line voltage junction box**  
The junction box contains the connection points for the line voltage power and all pumps.
28. **Line voltage wiring connections (knockouts)**  
Conduit connection points for the high voltage junction box.
29. **Low gas pressure switch**  
Switch provided to detect low gas pressure.
30. **Low voltage connection board**  
The connection board is used to connect external low voltage devices.
31. **Low voltage wiring connections (knockouts)**  
Conduit connection points for the low voltage connection board.
32. **Low water cutoff device (LWCO)**  
Device used to ensure adequate water is supplied to the boiler and in the event of inadequate water levels, will ensure the boiler will shut down.
33. **Power switch**  
Turns 120 VAC ON/OFF to the boiler.
34. **Pump relay boards**  
The pump relay boards are used to connect the boiler, system and Hot Water Generator (HW) pumps.
35. **Relief valve**  
Protects the heat exchangers from an over pressure condition. The relief valve will be set at 50 PSI.
36. **Reset switch**  
Reset switch for the low water cutoff. Hold for 10 seconds to reset.
37. **Stainless steel heat exchangers**  
Allows system water to flow through specially designed coils for maximum heat transfer, while providing protection against flue gas corrosion. The coils are encased in a jacket that contains the combustion process.
38. **Temperature and pressure gauge**  
Monitors the outlet temperature of the boiler as well as the system water pressure.
39. **Test switch**  
Test switch for the low water cutoff. Hold for 10 seconds to test.
40. **Top panel**  
Removable panel to gain access to the internal components.
41. **Venturis**  
The venturis control air and gas flow into the burners.
42. **Water inlets**  
Two 2" NPT water connections that return water from the system to the heat exchangers.
43. **Water outlets**  
A 3" NPT water connection that supplies hot water to the system.
44. **O-temp switch (located underneath access cover)**  
An electrical switch designed to shut down boiler operation in the event the outer back of the heat exchanger, directly above the flue connection does not exceed 604°F (318°C). This is a one time switch and could warrant a heat exchanger replacement. Check the integrity of the rear refractory at the back of the upper coil if the switch opens.
45. **Burner door temperature switch**  
An electrical switch designed to shut down boiler operation in the event the combustion chamber access cover exceeds 500°F (260°C). This switch may only be reset by a qualified boiler service technician AFTER the underlying cause has been identified and corrected. Check the integrity of the front refractory on the inside of the combustion chamber access cover if the switch opens.

# The SYNC - How it works... (continued)

Models 1.0 - 1.3 - 1.5

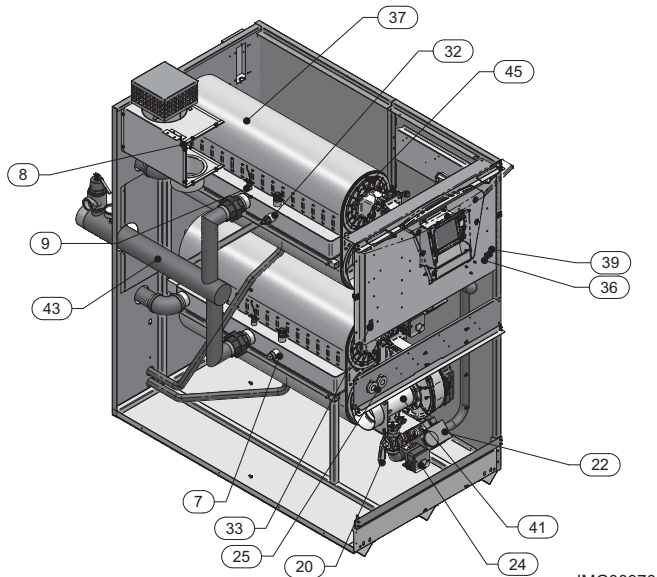
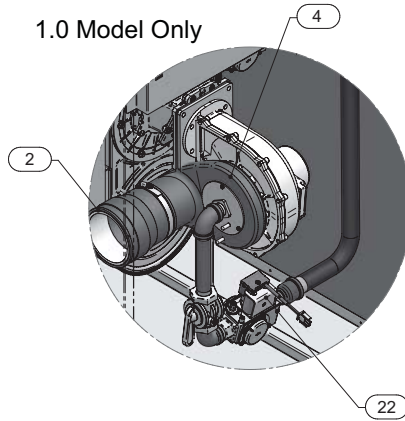


Front View



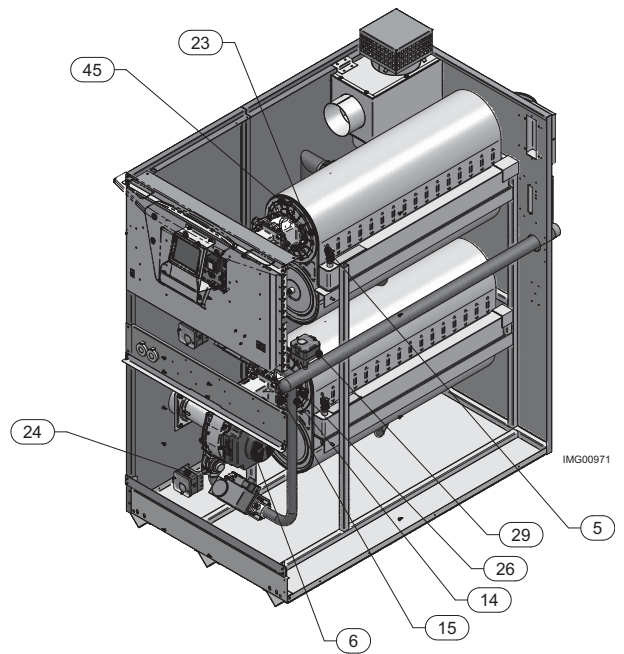
Rear View

1.0 Model Only



Left Side (inside unit)

IMG00970




Right Side (inside unit)

IMG00971

# Ratings



DOE

 SYNC AHRI Rating					Other Specifications					
Model Number  Note: Change "N" to "L" for L.P. gas models.	Input MBH (Note 4)		Gross Output MBH (Note 1)	Net AHRI Ratings Water, MBH (Note 2)	Appliance Water Content Gallons	Outlet Water	Inlet Water	Gas Connections	Air Size	Vent Size (Note 3)
	Min	Max								
SBN1000	100	1000	941	818	8.4	3"	(2) - 2"	1½"	6"	6"
SBN1300	130	1300	1237	1076	10.0	3"	(2) - 2"	1½"	6"	6"
SBN1500	150	1500	1444	1256	11.4	3"	(2) - 2"	1½"	6"	6"

**NOTICE** Maximum allowed working pressure is located on the rating plate.

**Notes:**

- The ratings are based on standard test procedures prescribed by the United States Department of Energy.
- Net AHRI ratings are based on net installed radiation of sufficient quantity for the requirements of the building and nothing need be added for normal piping and pickup. Ratings are based on a piping and pickup allowance of 1.15.
- SYNC boilers require special gas venting. Use only the vent materials and methods specified in the SYNC Installation and Operation Manual.
- Standard SYNC boilers are equipped to operate from sea level to 4,500 feet **only** with no adjustments. The boiler will de-rate by 4% for each 1,000 feet above sea level up to 4,500 feet.
- High altitude SYNC boilers are equipped to operate from 3,000 to 12,000 feet **only**. The boiler will de-rate by 2% for each 1,000 feet above sea level. High altitude models are manufactured with a different control module for altitude operation, but the operation given in this manual remains the same as the standard boilers. A high altitude label (as shown in FIG. A) is also affixed to the unit.

Derate values are based on proper combustion calibration and CO<sub>2</sub>'s adjusted to the recommended levels.

- Ratings have been confirmed by the Hydronics Section of AHRI.

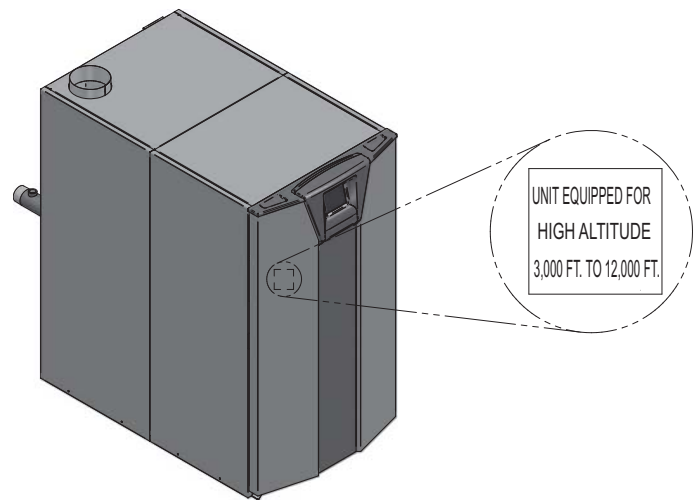


Figure A High Altitude Label Location

# 1 Determine boiler location

Installation must comply with:

- Local, state, provincial, and national codes, laws, regulations, and ordinances.
- National Fuel Gas Code, ANSI Z223.1 – latest edition.
- Standard for Controls and Safety Devices for Automatically Fired Boilers, ANSI/ASME CSD-1, when required.
- National Electrical Code.
- For Canada only: B149.1 Installation Code, CSA C22.1 Canadian Electrical Code Part 1 and any local codes.

## NOTICE

The SYNC gas manifold and controls met safe lighting and other performance criteria when the boiler underwent tests specified in ANSI Z21.13 – latest edition.

Before locating the boiler, check:

1. Check for nearby connection to:
  - System water piping
  - Venting connections
  - Gas supply piping
  - Electrical power
2. Locate the appliance so that if water connections should leak, water damage will not occur. When such locations cannot be avoided, it is recommended that a suitable drain pan, adequately drained, be installed under the appliance. The pan must not restrict combustion air flow. Under no circumstances is the manufacturer to be held responsible for water damage in connection with this appliance, or any of its components.
3. Check area around the boiler. Remove any combustible materials, gasoline and other flammable liquids.

## WARNING

Failure to keep boiler area clear and free of combustible materials, gasoline, and other flammable liquids and vapors can result in severe personal injury, death, or substantial property damage.

4. The SYNC must be installed so that gas control system components are protected from dripping or spraying water or rain during operation or service.
5. If a new boiler will replace an existing boiler, check for and correct system problems, such as:
  - System leaks causing oxygen corrosion or heat exchanger cracks from hard water deposits.
  - Incorrectly-sized expansion tank.
  - Lack of freeze protection in boiler water causing system and boiler to freeze and leak.
  - Debris left from existing piping, if not flushed and cleaned with an appropriate cleaner.
6. Check around the boiler for any potential air contaminants that could risk corrosion to the boiler or the boiler combustion air supply (see Table 1A on page 10). Prevent combustion air contamination. Remove any of these contaminants from the boiler area.

## WARNING

DO NOT install units in rooms or environments that contain corrosive contaminants (see Table 1A on page 10). Failure to comply could result in severe personal injury, death, or substantial property damage.

## WARNING

This appliance is certified as an indoor appliance. Do not install the appliance outdoors or locate where the appliance will be exposed to freezing temperatures or to temperatures that exceed 100°F.

Do not install the appliance where the relative humidity may exceed 93%. Do not install the appliance where condensation may form on the inside or outside of the appliance, or where condensation may fall onto the appliance.

Failure to install the appliance indoors could result in severe personal injury, death, or substantial property damage.

## WARNING

This appliance requires a special venting system. Use only the vent materials, primer and cement specified in this manual to make the vent connections. Failure to follow this warning could result in fire, personal injury, or death.

## Closet and alcove installations

A closet is any room the boiler is installed in which is less than 778 cubic feet for SB1000 models, 847 cubic feet for SB1300 models, and 914 cubic feet for SB1500 models.

An alcove is any room which meets the criteria for a closet with the exception that it does not have a door.

**Example:** Room dimensions = 9 feet long, 9 feet wide, and 9 foot ceiling = 9 x 9 x 9 = 729 cubic feet. This would be considered a closet for a SYNC Boiler.

## WARNING

For closet and alcove installations as shown in FIG.'s 1-1 and 1-2, CPVC or stainless steel vent material must be used inside the structure. The ventilating air openings shown in FIG.'s 1-1 and 1-2 are required for this arrangement. Failure to follow this warning could result in fire, personal injury, or death.

Provide clearances:

### Clearances from combustible materials

1. Hot water pipes – at least 1/4" (6 mm) from combustible materials.
2. Vent pipe – at least 1" (25 mm) from combustible materials.
3. See FIG.'s 1-1 and 1-2 on page 8 for other clearance minimums.

### Clearances for service access

1. See FIG.'s 1-1 and 1-2 on page 8 for recommended service clearances. If you do not provide the minimum clearances shown, it may not be possible to service the boiler without removing it from the space.

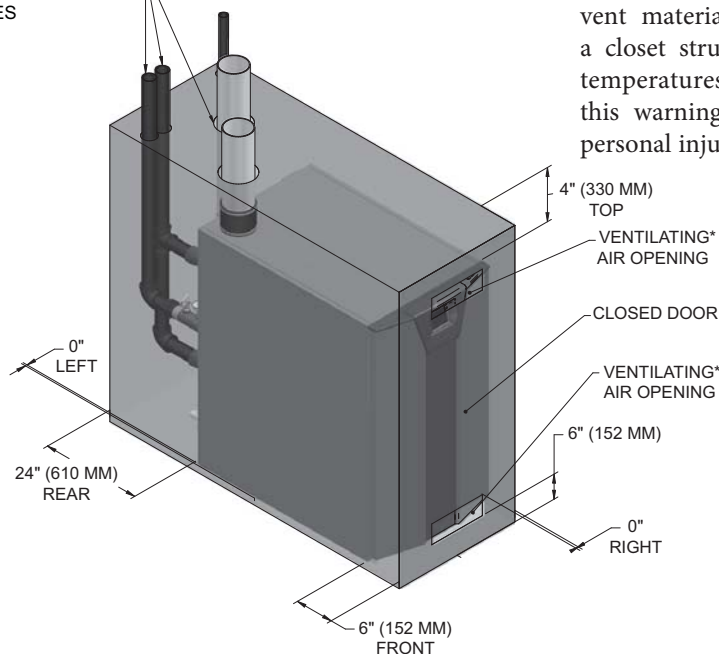
# 1 Determine boiler location

**Figure 1-1 Closet Installation - Minimum Required Clearances**

1/4" (6 MM) MINIMUM CLEARANCE  
AROUND HOT WATER PIPES  
1" (25 MM) MINIMUM CLEARANCE  
AROUND VENT PIPES



For closet installations, CPVC, polypropylene or stainless steel vent material **MUST BE** used in a closet structure due to elevated temperatures. Failure to follow this warning could result in fire, personal injury, or death.



**RECOMMENDED SERVICE CLEARANCES:**

- Front - 30" (762 mm)
- Top - 24" (610 mm)
- Left Side - 24" (610 mm)
- Rear - 24" (610 mm)

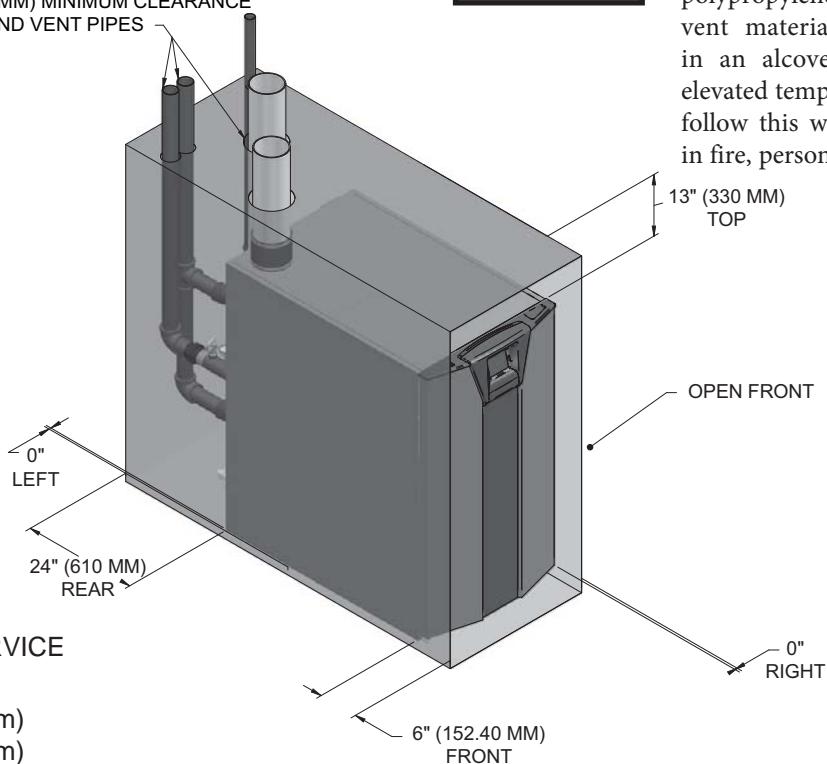
\*AREA OF EACH OPENING:  
1 SQ. INCH PER 1000 BTU PER HOUR INPUT  
WITH A MINIMUM OF 100 SQ. INCHES

**Figure 1-2 Alcove Installation - Minimum Required Clearances**

1/4" (6 MM) MINIMUM CLEARANCE  
AROUND HOT WATER PIPES  
1" (25 MM) MINIMUM CLEARANCE  
AROUND VENT PIPES



For alcove installations, CPVC, polypropylene or stainless steel vent material **MUST BE** used in an alcove structure due to elevated temperatures. Failure to follow this warning could result in fire, personal injury, or death.



**RECOMMENDED SERVICE CLEARANCES:**

- Front - 30" (762 mm)
- Top - 24" (610 mm)
- Left Side - 24" (610 mm)
- Rear - 24" (610 mm)

# 1 Determine boiler location *(continued)*

Provide air openings to room:

## The SYNC alone in boiler room

1. No air ventilation openings into the boiler room are needed when clearances around the SYNC are at least equal to the SERVICE clearances shown in FIG.'s 1-1 and 1-2. For spaces that do NOT supply this clearance, provide two openings as shown in FIG. 1-1. Each opening must provide one square inch free area per 1,000 Btu/hr of boiler input.
2. Combustion air openings are required when using the Room Air Option on page 18 of this manual.

## The SYNC in same space with other gas or oil-fired appliances

1. Follow the National Fuel Gas Code (U.S.) or CSA B149.1 (Canada) to size/verify size of the combustion/ventilation air openings into the space.

**⚠ WARNING** The space must be provided with combustion/ventilation air openings correctly sized for all other appliances located in the same space as the SYNC.

Do not install the boiler in an attic.

Failure to comply with the above warnings could result in severe personal injury, death, or substantial property damage.

2. Size openings only on the basis of the other appliances in the space. No additional air opening free area is needed for the SYNC because it takes its combustion air from outside (direct vent installation).

## Flooring and foundation

### Flooring

The SYNC is approved for installation on combustible flooring, but must never be installed on carpeting.

**⚠ WARNING** Do not install the boiler on carpeting even if foundation is used. Fire can result, causing severe personal injury, death, or substantial property damage.

If flooding is possible, elevate the boiler sufficiently to prevent water from reaching the boiler.

## Vent and air piping

The SYNC requires a special vent system, designed for pressurized venting.

The boiler is to be used for either direct vent installation or for installation using indoor combustion air. When room air is considered, see Section 4, Vertical Direct Venting. Note prevention of combustion air contamination below when considering vent/air termination.

Vent and air must terminate near one another and may be vented vertically through the roof or out a side wall, unless otherwise specified. You may use any of the vent/air piping methods covered in this manual. Do not attempt to install the SYNC using any other means.

Be sure to locate the boiler such that the vent and air piping can be routed through the building and properly terminated. The vent/air piping lengths, routing and termination method must all comply with the methods and limits given in this manual.

## Prevent combustion air contamination

Install air inlet piping for the SYNC as described in this manual. Do not terminate vent/air in locations that can allow contamination of combustion air. Refer to Table 1A, page 10 for products and areas which may cause contaminated combustion air.

**⚠ WARNING** Ensure that the combustion air will not contain any of the contaminants in Table 1A, page 10. Contaminated combustion air will damage the boiler, resulting in possible severe personal injury, death or substantial property damage. Do not pipe combustion air near a swimming pool, for example. Also, avoid areas subject to exhaust fumes from laundry facilities. These areas will always contain contaminants.

# 1 Determine boiler location

**Table 1A Corrosive Contaminants and Sources**

Products to avoid:
Spray cans containing chloro/fluorocarbons
Permanent wave solutions
Chlorinated waxes/cleaners
Chlorine-based swimming pool chemicals
Calcium chloride used for thawing
Sodium chloride used for water softening
Refrigerant leaks
Paint or varnish removers
Hydrochloric acid/muriatic acid
Cements and glues
Antistatic fabric softeners used in clothes dryers
Chlorine-type bleaches, detergents, and cleaning solvents found in household laundry rooms
Adhesives used to fasten building products and other similar products
Areas likely to have contaminants
Dry cleaning/laundry areas and establishments
Swimming pools
Metal fabrication plants
Beauty shops
Refrigeration repair shops
Photo processing plants
Auto body shops
Plastic manufacturing plants
Furniture refinishing areas and establishments
New building construction
Remodeling areas
Garages with workshops

When using an existing vent system to install a new boiler:

**⚠ WARNING**

Failure to follow all instructions can result in flue gas spillage and carbon monoxide emissions, causing severe personal injury or death.

Check the following venting components before installing:

- **Material** - For materials listed for use with this appliance, see Section 2 - General Venting. For polypropylene or stainless steel venting, an adapter of the same manufacturer must be used at the flue collar connection.
- **Size** - To ensure proper pipe size is in place, see Table 2A. Check to see that this size is used throughout the vent system.
- **Manufacturer** - For a stainless steel or polypropylene application, you must use only the listed manufacturers and their type product listed in Tables 2D and 2F for CAT IV positive pressure venting with flue producing condensate.
- **Supports** - Non-combustible supports must be in place allowing a minimum 1/4" rise per foot. The supports should adequately prevent sagging and vertical slippage, by distributing the vent system weight. For additional information, consult the vent manufacturer's instructions for installation.
- **Terminations** - Carefully review Sections 2 through 4 to ensure requirements for the location of the vent and air terminations are met and orientation of these fit the appropriate image from the Sidewall or Vertical options listed in the General Venting Section. For stainless steel vent, only use terminations listed in Table 2F for the manufacturer of the installed vent.
- **Seal** - With prior requirements met, the system should be tested to the procedure listed in parts (c) through (f) of the Removal of an Existing Boiler Section on page 11.

With polypropylene and stainless steel vent, seal and connect all pipe and components as specified by the vent manufacturer used; with PVC/CPVC vent, see the Installing Vent or Air Piping Section on page 19.

**⚠ WARNING**

If any of these conditions are not met, the existing system must be updated or replaced for that concern. Failure to follow all instructions can result in flue gas spillage and carbon monoxide emissions, causing severe personal injury or death.

# 1 Determine boiler location *(continued)*

When removing a boiler from existing common vent system:

**⚠ DANGER**

Do not install the SYNC into a common vent with any other appliance. This will cause flue gas spillage or appliance malfunction, resulting in possible severe personal injury, death, or substantial property damage.

**⚠ WARNING**

Failure to follow all instructions can result in flue gas spillage and carbon monoxide emissions, causing severe personal injury or death.

At the time of removal of an existing boiler, the following steps shall be followed with each appliance remaining connected to the common venting system placed in operation, while the other appliances remaining connected to the common venting system are not in operation.

- a. Seal any unused openings in the common venting system.
- b. Visually inspect the venting system for proper size and horizontal pitch and determine there is no blockage or restriction, leakage, corrosion, or other deficiencies, which could cause an unsafe condition.
- c. Test vent system – Insofar as is practical, close all building doors and windows and all doors between the space in which the appliances remaining connected to the common venting system are located and other spaces of the building. Turn on clothes dryers and any appliance not connected to the common venting system. Turn on any exhaust fans, such as range hoods and bathroom exhausts, so they will operate at maximum speed. Do not operate a summer exhaust fan. Close fireplace dampers.
- d. Place in operation the appliance being inspected. Follow the lighting instructions. Adjust thermostat so appliance will operate continuously.
- e. Test for spillage at the draft hood relief opening after 5 minutes of main burner operation. Use the flame of a match or candle, or smoke from a cigarette, cigar, or pipe.
- f. After it has been determined that each appliance remaining connected to the common venting system properly vents when tested as outlined herein, return doors, windows, exhaust fans, fireplace dampers, and any other gas-burning appliance to their previous conditions of use.
- g. Any improper operation of the common venting system should be corrected so the installation conforms with the National Fuel Gas Code, ANSI Z223.1/NFPA 54 and/or CAN/CSA B149.1, Natural Gas and Propane Installation Code. When resizing any portion of the common venting system, the common venting system should be resized to approach the minimum size as determined using the appropriate tables in Part 11 of the National Fuel Gas Code, ANSI Z223.1/NFPA and/or CAN/CSA B149.1, Natural Gas and Propane Installation Code.

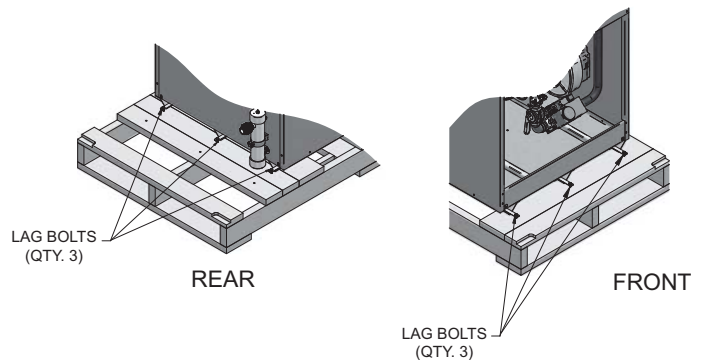
Remove boiler from wood pallet

1. After removing the outer shipping carton from the boiler, remove the parts package (packaged parts inside the jacket of the boiler).
2. To remove the boiler from the pallet:
  - a. Remove the front door of the boiler.
  - b. Remove the two lag bolts from the wood pallet inside the boiler (FIG. 1-3).
  - c. Detach the boiler from the lag bolts in the rear of the unit, see FIG. 1-3.

**NOTICE**

Do not drop the boiler or bump the jacket on the floor or pallet. Damage to the boiler can result.

**Figure 1-3 Boiler Mounted on Shipping Pallet**



Maintain minimum specified clearances for adequate operation. All installations must allow sufficient space for servicing the vent connections, water pipe connections, piping and other auxiliary equipment, as well as the appliance. The clearance labels on each appliance note the same service and combustible clearance requirements as shown in this manual.

Multiple appliances may be installed in a modular boiler installation. Multiple appliances may be installed side by side with no clearance between adjacent appliances because this appliance is approved for zero clearance from combustible surfaces and no service access is required from the sides.

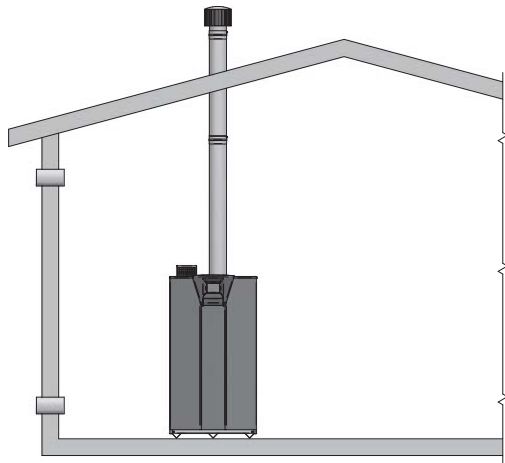
Consult the *Venting* section of this manual for specific installation instructions for the appropriate type of venting system that you will be using.

# 1 Determine boiler location

Combustion and ventilation air requirements for appliances drawing air from the equipment room

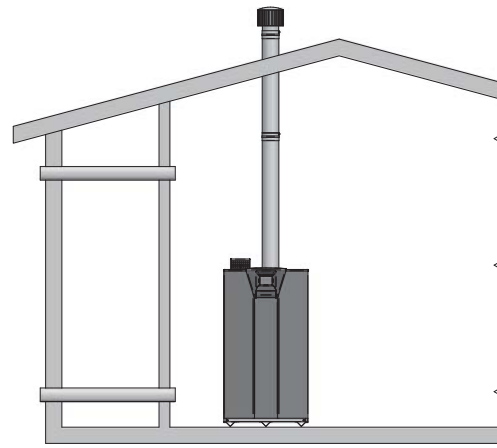
Provisions for combustion and ventilation air must be in accordance with Air for Combustion and Ventilation, of the latest edition of the National Fuel Gas Code, ANSI Z223.1, in Canada, the latest edition of CGA Standard B149 Installation Code for Gas Burning Appliances and Equipment, or applicable provisions of the local building codes.

The equipment room **MUST** be provided with properly sized openings to assure adequate combustion air and proper ventilation.



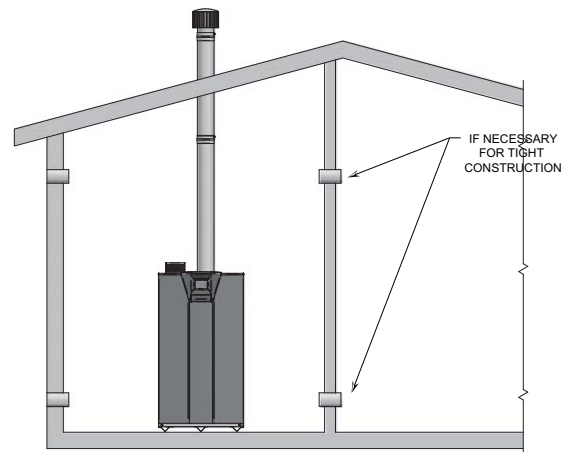
**Figure 1-4** Combustion Air Direct from Outside

1. If air is taken directly from outside the building with no duct, provide two permanent openings to the equipment room (see FIG. 1-4):
  - (a) Combustion air opening, with a minimum free area of one square inch per 4000 Btu/hr input (5.5 cm<sup>2</sup> per kW). This opening must be located within 12" (30 cm) of the bottom of the enclosure.
  - (b) Ventilation air opening, with a minimum free area of one square inch per 4000 Btu/hr input (5.5 cm<sup>2</sup> per kW). This opening must be located within 12" (30 cm) of the top of the enclosure.



**Figure 1-5** Combustion Air Through Ducts

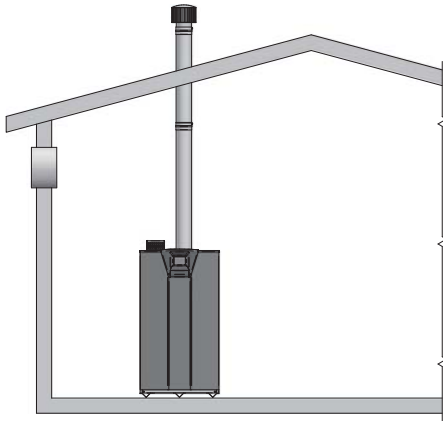
2. If combustion and ventilation air is taken from the outdoors using a duct to deliver the air to the equipment room, each of the two openings should be sized based on a minimum free area of one square inch per 2000 Btu/hr (11 cm<sup>2</sup> per kW) of input (see FIG. 1-5).



**Figure 1-6** Combustion Air from Interior Space

3. If air is taken from another interior space, each of the two openings specified above should have a net free area of one square inch for each 1000 Btu/hr (22 cm<sup>2</sup> per kW) of input, but not less than 100 square inches (645 cm<sup>2</sup>) (see FIG. 1-6).

# 1 Determine boiler location *(continued)*



**Figure 1-7\_Combustion Air from Outside - Single Opening**

- If a single combustion air opening is provided to bring combustion air in directly from the outdoors, the opening must be sized based on a minimum free area of one square inch per 3000 Btu/hr (7 cm<sup>2</sup> per kW). This opening must be located within 12" (30 cm) of the top of the enclosure (see FIG. 1-7).

Combustion air requirements are based on the latest edition of the National Fuel Gas Code, ANSI Z223.1; in Canada refer to the latest edition of CGA Standard CAN B149.1. Check all local code requirements for combustion air.

All dimensions based on net free area in square inches. Metal louvers or screens reduce the free area of a combustion air opening a minimum of approximately 25%. Check with louver manufacturers for exact net free area of louvers.

Where two openings are provided, one must be within 12" (30cm) of the ceiling and one must be within 12" (30cm) of the floor of the equipment room. Each opening must have net free area as specified in the chart below (Table 1B). Single openings shall commence within 12" (30cm) of the ceiling.

**CAUTION**

Under no circumstances should the equipment room ever be under negative pressure. Particular care should be taken where exhaust fans, attic fans, clothes dryers, compressors, air handling units, etc., may take away air from the unit.

The combustion air supply must be completely free of any flammable vapors that may ignite or chemical fumes which may be corrosive to the appliance. Common corrosive chemical fumes which must be avoided are fluorocarbons and other halogenated compounds, most commonly present as refrigerants or solvents, such as Freon, trichlorethylene, perchlorethylene, chlorine, etc. These chemicals, when burned, form acids which quickly attack the stainless steel heat exchanger, headers, flue collectors, and the vent system.

The result is improper combustion and a non-warrantable, premature appliance failure.

**EXHAUST FANS:** Any fan or equipment which exhausts air from the equipment room may deplete the combustion air supply and/or cause a downdraft in the venting system. Spillage of flue products from the venting system into an occupied living space can cause a very hazardous condition that must be corrected immediately.

TABLE - 1B MINIMUM RECOMMENDED COMBUSTION AIR SUPPLY TO EQUIPMENT ROOM							
Model Number	FIG. 1-4		FIG. 1-5		FIG. 1-6		FIG. 1-7
	*Outside Air from 2 Openings Directly from Outdoors		*Outside Air from 2 Ducts Delivered from Outdoors		**Inside Air from 2 Ducts Delivered from Interior Space		*Outside Air from 1 Opening Directly from Outdoors, in <sup>2</sup>
	Top Opening, in <sup>2</sup>	Bottom Opening, in <sup>2</sup>	Top Opening, in <sup>2</sup>	Bottom Opening, in <sup>2</sup>	Top Opening, in <sup>2</sup>	Bottom Opening, in <sup>2</sup>	
1.0	250 (1613 cm <sup>2</sup> )	250 (1613 cm <sup>2</sup> )	500 (3226 cm <sup>2</sup> )	500 (3226 cm <sup>2</sup> )	1000 (6452 cm <sup>2</sup> )	1000 (6452 cm <sup>2</sup> )	333 (2149 cm <sup>2</sup> )
1.3	325 (2097 cm <sup>2</sup> )	325 (2097 cm <sup>2</sup> )	650 (4194 cm <sup>2</sup> )	650 (4194 cm <sup>2</sup> )	1300 (8388 cm <sup>2</sup> )	1300 (8388 cm <sup>2</sup> )	433 (2794 cm <sup>2</sup> )
1.5	375 (2420 cm <sup>2</sup> )	375 (2420 cm <sup>2</sup> )	750 (4839 cm <sup>2</sup> )	750 (4839 cm <sup>2</sup> )	1500 (9678 cm <sup>2</sup> )	1500 (9678 cm <sup>2</sup> )	500 (3226 cm <sup>2</sup> )

\*Outside air openings shall directly communicate with the outdoors. When combustion air is drawn from the outside through a duct, the net free area of each of the two openings must have twice (2 times) the free area required for Outside Air/2 Openings. The above requirements are for the appliance only; additional gas fired appliances in the equipment room will require an increase in the net free area to supply adequate combustion air for all appliances.

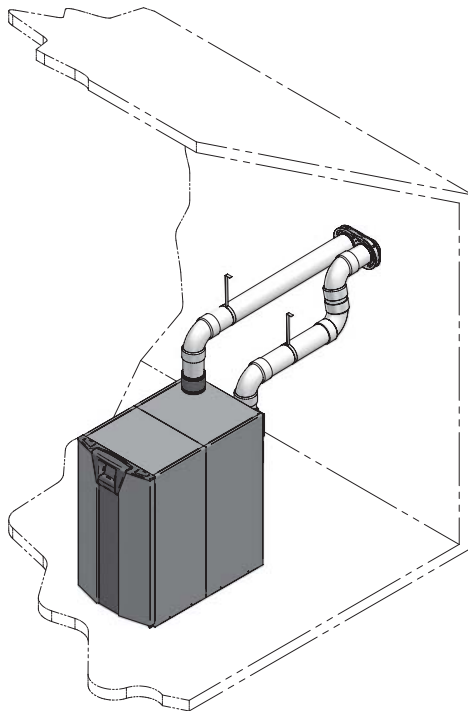
\*\*Combined interior space must be 50 cubic feet per 1,000 Btu/hr input. **Buildings MUST NOT be of "Tight Construction"**. For buildings of **"Tight Construction"**, provide air openings into the building from outside.

\*No combustion air openings are needed when the appliance is installed in a space with a volume NO LESS than 50 cubic feet per 1,000 Btu/hr of all installed gas fired appliances. **Buildings MUST NOT be of "Tight Construction"**.

\*\*"Tight Construction" is defined as a building with less than 0.40 ACH (air changes per hour).

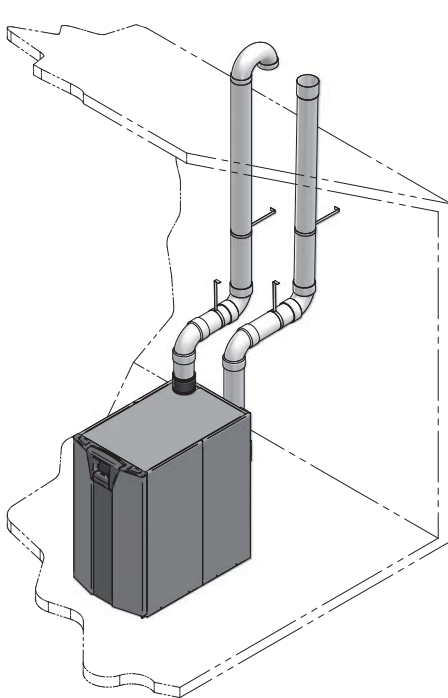
## 2 General venting

### Direct venting options - Sidewall Vent

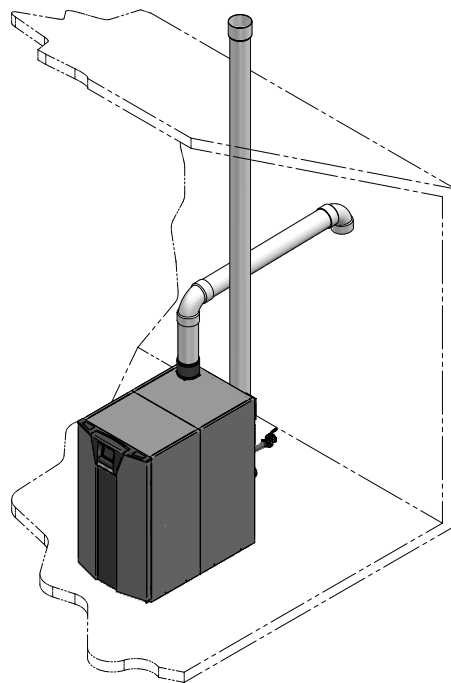


**Figure 2-1** Two Pipe Sidewall Termination -  
See page 22 for more details

### Direct venting options - Vertical Vent



**Figure 2- 2** Two Pipe Vertical Termination -  
See page 26 for more details



**Figure 2-3** Vertical Vent, Sidewall Air

## 2 General venting *(continued)*

### Install vent and combustion air piping

#### **⚠ DANGER**

The SYNC boiler must be vented and supplied with combustion and ventilation air as described in this section. Ensure the vent and air piping and the combustion air supply comply with these instructions regarding vent system, air system, and combustion air quality. See also Section 1 of this manual.

Inspect finished vent and air piping thoroughly to ensure all are airtight and comply with the instructions provided and with all requirements of applicable codes.

Failure to provide a properly installed vent and air system will cause severe personal injury or death.

#### **⚠ WARNING**

This appliance requires a special venting system. Use only approved stainless steel, PVC, CPVC or polypropylene pipe and fittings listed in Tables 2C, 2D, and 2F for vent pipe, and fittings. Failure to comply could result in severe personal injury, death, or substantial property damage.

#### **⚠ WARNING**

DO NOT mix components from different systems. The vent system could fail, causing leakage of flue products into the living space. Mixing of venting materials will void the warranty and certification of the appliance.

#### **NOTICE**

Installation must comply with local requirements and with the National Fuel Gas Code, ANSI Z223.1 for U.S. installations or CSA B149.1 for Canadian installations.

#### **⚠ WARNING**

For closet and alcove installations, CPVC, polypropylene or stainless steel material **MUST BE** used in a closet/alcove structure. Failure to follow this warning could result in fire, personal injury, or death.

#### **⚠ CAUTION**

Improper installation of venting systems may result in injury or death.

#### **NOTICE**

Follow the instructions in Section 1, page 11 of this manual when removing a boiler from an existing vent system.

#### **⚠ WARNING**

Do not connect any other appliance to the vent pipe or multiple boilers to a common vent pipe. Failure to comply could result in severe personal injury, death, or substantial property damage.

The SYNC boiler vent and air piping can be installed through the roof or through a sidewall. Follow the procedures in this manual for the method chosen. Refer to the information in this manual to determine acceptable vent and air piping length.

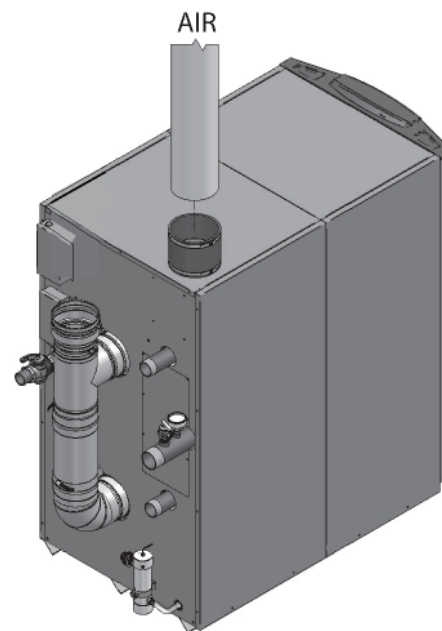
You may use any of the vent/air piping methods covered in this manual. Do not attempt to install the SYNC boiler using any other means.

You must also install air piping from outside to the boiler air intake adapter unless following the Optional Room Air instructions on page 18 of this manual. The resultant installation is direct vent (sealed combustion).

#### Air intake/vent connections

1. **Combustion Air Intake Connector** (FIG. 2-4) - Used to provide combustion air directly to the unit from outdoors. A fitting is provided on the unit for final connection. Combustion air piping must be supported per guidelines listed in the National Mechanical Code, Section 305, Table 305.4 or as local codes dictate.
2. **Vent Connector** (FIG.'s 2-5 thru 2-8) - Used to provide a passageway for conveying combustion gases to the outside. A transition fitting is provided on the unit for final connection. Vent piping must be supported per the National Building Code, Section 305, Table 305.4 or as local codes dictate.

**Figure 2-4 Near Boiler Air Piping**



## 2 General venting

### Requirements for installation in Canada

1. Installations must be made with a vent pipe system certified to ULC-S636.
2. The first three (3) feet of plastic vent pipe from the appliance flue outlet must be readily accessible for visual inspection.
3. The components of the certified vent system must not be interchanged with other vent systems or unlisted pipe/fittings.

### Sizing

The SYNC boiler uses model specific combustion air intake and vent piping sizes as detailed in Table 2A below.

When determining equivalent combustion air and vent length, add 5 feet for each 90° elbow and 3 feet for each 45° elbow.

**EXAMPLE:** 20 feet of PVC pipe + (4) 90° elbows + (2) 45° elbows + (1) concentric vent kit (100140480) = 49 equivalent feet of piping.

**Table 2A** Air Intake/Vent Piping Sizes

Model	Air Intake Diameter	Air Intake Min. Length	Air Intake Max. Length	Vent Diameter	Vent Min. Length	Vent Max. Length	Input De-Rate per 25 feet of Vent
SB 1000	6"	12'	100'	6"	12'	100'	1.25%
SB 1300	6"	12'	50'	6"	12'	50'	2.90%
SB 1300	7"	12'	100'	7"	12'	100'	0.95%
SB 1500	6"	12'	50'	6"	12'	50'	3.30%
SB 1500	7"	12'	100'	7"	12'	100'	1.65%

**Note:** When using a 7" vent or air pipe, a field supplied increaser is required.

**NOTICE**

Increasing or decreasing combustion air or vent piping sizes is not authorized.

## 2 General venting *(continued)*

### Materials

#### Air inlet pipe materials:

The air inlet pipe(s) must be sealed. Choose acceptable combustion air inlet pipe materials from the following list:

PVC, CPVC, Polypropylene or ABS

Dryer Vent or Sealed Flexible Duct (not recommended for rooftop air inlet)

Galvanized steel vent pipe with joints and seams sealed as specified in this section.

Type “B” double-wall vent with joints and seams sealed as specified in this section.

AL29-4C, stainless steel material to be sealed to specification of its manufacturer.

\*Plastic pipe may require an adapter (not provided) to transition between the air inlet connection on the appliance and the plastic air inlet pipe.

**⚠ WARNING**

Using air intake materials other than those specified can result in personal injury, death or property damage.

**NOTICE**

The use of double-wall vent or insulated material for the combustion air inlet pipe is recommended in cold climates to prevent the condensation of airborne moisture in the incoming combustion air.

Sealing of Type “B” double-wall vent material or galvanized vent pipe material used for air inlet piping on a sidewall or vertical rooftop Combustion Air Supply System:

- Seal all joints and seams of the air inlet pipe using either Aluminum Foil Duct Tape meeting UL Standard 723 or 181A-P or a high quality UL Listed silicone sealant such as those manufactured by Dow Corning or General Electric.
- Do not install seams of vent pipe on the bottom of horizontal runs.
- Secure all joints with a minimum of three (3) sheet metal screws or pop rivets. Apply Aluminum Foil Duct Tape or silicone sealant to all screws or rivets installed in the vent pipe.
- Ensure that the air inlet pipes are properly supported.

The PVC, CPVC, or ABS air inlet pipe should be cleaned and sealed with the pipe manufacturer’s recommended solvents and standard commercial pipe cement for the material used. The PVC, CPVC, ABS, Dryer Vent or Flex Duct air inlet pipe should use a silicone sealant to ensure a proper seal at the appliance connection and the air inlet cap connection. Dryer vent or flex duct should use a screw type clamp to seal the vent to the appliance air inlet and the air inlet cap. Proper sealing of the air inlet pipe ensures that combustion air will be free of contaminants and supplied in proper volume.

When a sidewall or vertical rooftop combustion air supply system is disconnected for any reason, the air inlet pipe must be resealed to ensure that combustion air will be free of contaminants and supplied in proper volume.

**⚠ DANGER**

Failure to properly seal all joints and seams as required in the air inlet piping may result in flue gas recirculation, spillage of flue products and carbon monoxide emissions causing severe personal injury or death.

## 2 General venting

### Optional room air

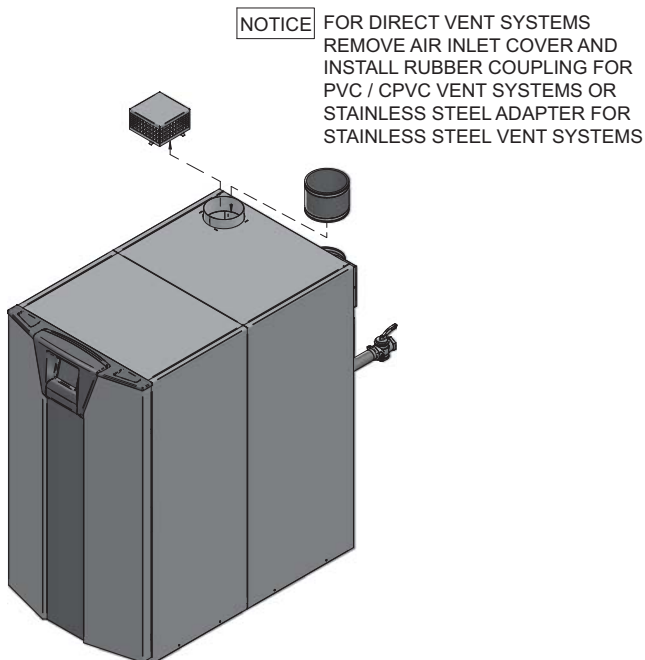
Applications utilizing the SYNC boiler may be installed with a single pipe carrying the flue products to the outside while using combustion air from the equipment room. In order to use the room air venting option the following conditions and considerations must be followed.

- The unit **MUST** be installed with the appropriate room air inlet cover (factory installed).
- The equipment room **MUST** be provided with properly sized openings to assure adequate combustion air. Please refer to instructions provided with the room air kit.
- There will be a noticeable increase in the noise level during normal operation from the inlet air opening.
- Using the room air configuration makes the unit vulnerable to combustion air contamination from within the building. Please review Section 1, Prevent Combustion Air Contamination, to ensure proper installation.
- Vent system and terminations must comply with the standard venting instructions set forth in this manual.

#### **⚠ WARNING**

When utilizing the single pipe method, provisions for combustion and ventilation air must be in accordance with Air for Combustion and Ventilation, of the latest edition of the National Fuel Gas Code, ANSI Z223.1, in Canada, the latest edition of CGA Standard B149 Installation Code for Gas Burning Appliances and Equipment, or applicable provisions of the local building codes.

**Figure 2-5 Room Air Installation**



**Table 2B Room Air Minimum / Maximum Allowable Air / Vent Lengths**

Model	Vent Diameter	Vent Min. Length	Vent Max. Length	Input De-Rate per 25 feet of Vent
SB 1000	6"	12'	100'	0.63%
SB 1300	6"	12'	50'	1.45%
SB 1300	7"	12'	50' - 100'	1.45%
SB 1500	6"	12'	50'	1.65%
SB 1500	7"	12'	50' - 100'	1.65%

#### **Air contamination**

Pool and laundry products and common household and hobby products often contain fluorine or chlorine compounds. When these chemicals pass through the boiler, they can form strong acids. The acid can eat through the boiler wall, causing serious damage and presenting a possible threat of flue gas spillage or boiler water leakage into the building.

Please read the information given in Table 1A, page 10, listing contaminants and areas likely to contain them. If contaminating chemicals will be present near the location of the boiler combustion air inlet, have your installer pipe the boiler combustion air and vent to another location, per this manual.

#### **⚠ WARNING**

If the boiler combustion air inlet is located in a laundry room or pool facility, for example, these areas will always contain hazardous contaminants.

#### **⚠ WARNING**

To prevent the potential of severe personal injury or death, check for areas and products listed in Table 1A, page 10 before installing the boiler or air inlet piping.

If contaminants are found, you **MUST**:

- Remove contaminants permanently.
- OR—
- Relocate air inlet and vent terminations to other areas.

## 2 General venting *(continued)*

### PVC/CPVC

This product has been approved for use with the PVC/CPVC vent materials listed in Table 2C.

#### Installing vent and air piping

**⚠ WARNING** For all installations, the first ten (10) equivalent feet of vent must be CPVC or stainless steel (see FIG. 2-6). The field provided vent fittings must be cemented to the CPVC pipe section using an “All Purpose Cement” suitable for PVC and CPVC pipe. Use only the vent materials, primer, and cement specified in Table 2C to make the vent connections. Failure to follow this warning could result in fire, personal injury, or death.

**NOTICE** Use only cleaners, primers, and solvents that are approved for the materials which are joined together.

**NOTICE** All PVC vent pipes must be glued, properly supported, and the exhaust must be pitched a minimum of a 1/4 inch per foot back to the boiler (to allow drainage of condensate).

**⚠ WARNING** Insulation should not be used on PVC or CPVC venting materials. The use of insulation will cause increased vent wall temperatures, which could result in vent pipe failure.

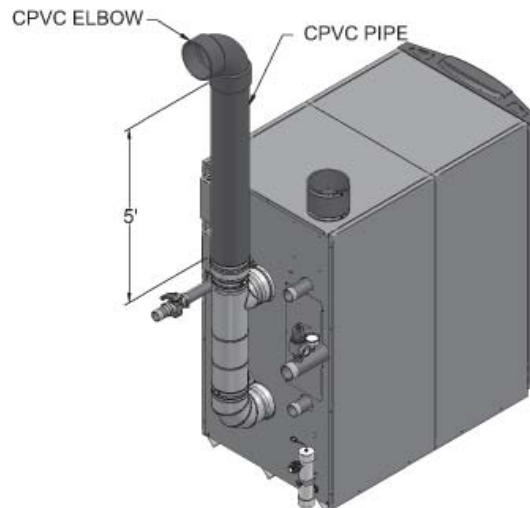
1. Work from the boiler to vent or air termination. Do not exceed the lengths given in this manual for the air or vent piping.
2. Cut pipe to the required lengths and deburr the inside and outside of the pipe ends.
3. Chamfer outside of each pipe end to ensure even cement distribution when joining.
4. Clean all pipe ends and fittings using a clean dry rag. (Moisture will retard curing and dirt or grease will prevent adhesion.)
5. Dry fit vent or air piping to ensure proper fit up before assembling any joint. The pipe should go a third to two-thirds into the fitting to ensure proper sealing after cement is applied.
6. Priming and Cementing:
  - a. Handle fittings and pipes carefully to prevent contamination of surfaces.
  - b. Apply a liberal even coat of primer to the fitting socket and to the pipe end to approximately 1/2" beyond the socket depth.
  - c. Apply a second primer coat to the fitting socket.
  - d. While primer is still wet, apply an even coat of approved cement to the pipe equal to the depth of the fitting socket along with an even coat of approved cement to the fitting socket.
  - e. Apply a second coat of cement to the pipe.
  - f. While the cement is still wet, insert the pipe into the fitting, if possible twist the pipe a 1/4 turn as you insert it. **NOTE:** If voids are present, sufficient cement was not applied and joint could be defective.
  - g. Wipe excess cement from the joint removing ring or beads as it will needlessly soften the pipe.

**Table 2C** PVC/CPVC Vent Pipe and Fittings

Approved PVC/CPVC Vent Pipe and Fittings		
Item	Material	Standard
Vent pipe	PVC Schedule 40, 80	ANSI/ASTM D1785
	PVC - DWV	ANSI/ASTM D2665
	CPVC Schedule 40, 80	ANSI/ASTM F441
Vent fittings	PVC Schedule 40	ANSI/ASTM D2466
	PVC Schedule 80	ANSI/ASTM D2467
	CPVC Schedule 80	ANSI/ASTM F439
	PVC - DWV	ANSI/ASTM D2665
Pipe Cement / Primer	PVC	ANSI/ASTM D2564
	CPVC	ANSI/ASTM F493
<b>NOTICE: DO NOT USE CELLULAR (FOAM) CORE PIPE</b>		

**NOTE:** In Canada, CPVC and PVC vent pipe, fittings and cement/primer must be ULC-S636 certified.

**Figure 2-6** Near Boiler PVC/CPVC Venting



## 2 General venting

### Polypropylene

This product has been approved for use with polypropylene vent with the manufacturers listed in Table 2D.

All terminations must comply with listed options in this manual and be a single-wall vent offering.

For use of flex pipe, it is recommended to have the vent material in 32°F or higher ambient space before bending at installation. No bends should be made to greater than 45° and ONLY installed in vertical or near vertical installations.

For support and special connections required, see the manufacturer's instructions. All vent is to conform to standard diameter and equivalent length requirements established.

**Table 2D Polypropylene Vent Pipe and Fittings**

Approved Polypropylene Vent Manufacturers	
Make	Model
Centrotherm Eco Systems	InnoFlue SW/Flex
DuraVent (M & G Group)	PolyPro Single-Wall / PolyPro Flex

#### NOTICE

The installer must use a specific vent starter adapter at the flue collar connection, supplied by the vent manufacturer to adapt to its vent system. See Table 2E for approved vent adapters. Discard CPVC starter piece.

#### WARNING

Insulation should not be used on polypropylene venting materials. The use of insulation will cause increased vent wall temperatures, which could result in vent pipe failure.

#### WARNING

Use only the adapters and vent system listed in Tables 2E and 2F. DO NOT mix vent systems of different types or manufacturers. Failure to comply could result in severe personal injury, death, or substantial property damage.

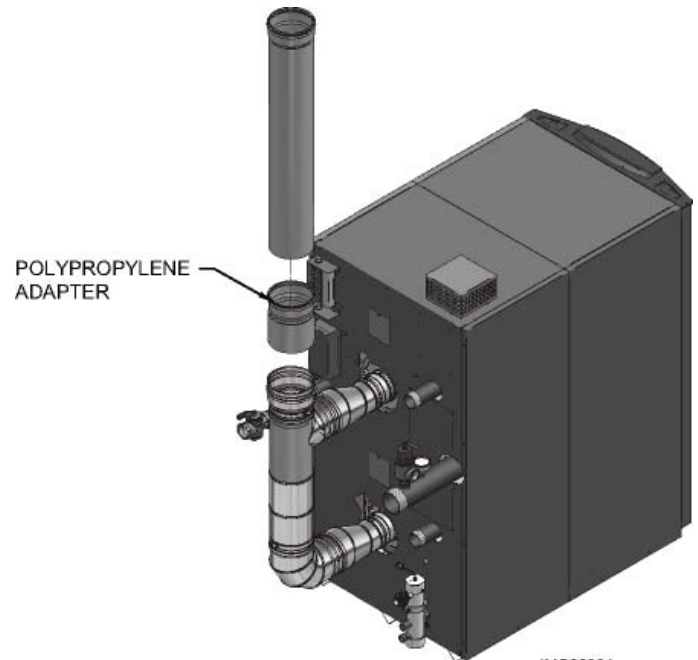
#### NOTICE

Installations must comply with applicable national, state, and local codes. For Canadian installation, polypropylene vent must be listed as a ULC-S636 approved system.

#### NOTICE

Installation of a polypropylene vent system should adhere to the vent manufacturer's installation instructions supplied with the vent system.

**Figure 2-7 Near Boiler Polypropylene Venting**



IMG00024

**Table 2E Approved Polypropylene Terminations**

Model	Centrotherm InnoFlue SW				DuraVent Polypro		
	Polypropylene Adapter	Joint Connector	Sidewall Retaining Bracket*	Sidewall Adapter*	Polypropylene Adapter	Joint Connector	Sidewall Kit*
1000 -1500	ISAAL0606	Not Required	IATP0606	ISTAGL0606	6PPS-06PVC-6PPF	N/A	6PPS-HLK

\* These parts are only needed if the sidewall termination assembly is used (see FIG. 3-4B on page 24).

## 2 General venting *(continued)*

### Stainless steel vent

This product has been approved for use with stainless steel using only FasNSeal vent systems.

**⚠ WARNING** Use only the materials, vent systems, and terminations listed in Table 2F. DO NOT mix vent systems of different types or manufacturers. Failure to comply could result in severe personal injury, death, or substantial property damage.

**NOTICE** The installer must use a specific vent starter adapter at the flue collar connection, supplied by the vent manufacturer to adapt to its vent system. See Table 2F for approved vent adapters. Discard CPVC starter piece.

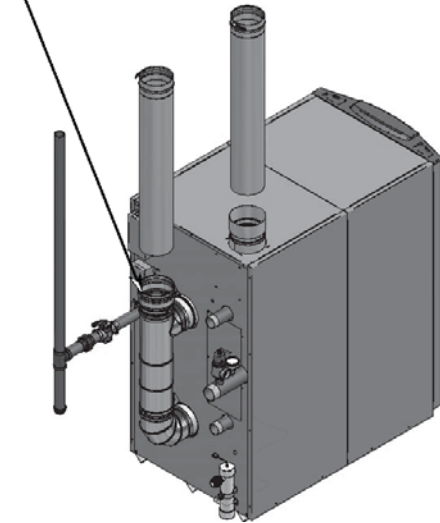
**NOTICE** Installations must comply with applicable national, state, and local codes. Stainless steel vent systems must be listed as a UL-1738 approved system for the United States and a ULC-S636 approved system for Canada.

**NOTICE** Installation of a stainless steel vent system should adhere to the stainless steel vent manufacturer's installation instructions supplied with the vent system.

**Figure 2-8 Near Boiler Stainless Steel Venting**

**NOTICE** PVC/CPVC or ABS is acceptable air inlet pipe material.

REMOVE PVC/CPVC VENT CONNECTOR WHEN INSTALLING STAINLESS STEEL



The SYNC uses model specific combustion air intake and vent piping sizes as detailed in Tables 2A and 2B.

**NOTICE** Increasing or decreasing combustion air or vent piping to sizes not specified in this manual is not authorized.

**Table 2F Approved Stainless Steel Terminations and Adapters**

STAINLESS STEEL VENT TERMINATION KITS			
Model	Kit Part Number	Component Description	
SB 1000 - 1500	100157602	6" PVC x 6" Stainless Steel Adapter	
		6" Stainless Steel Vent Termination	
		6" Stainless Steel Air Inlet	
SB 1300 - 1500	100157603	6" PVC x 6" Stainless Steel Adapter	
		6" Stainless Steel x 7" Stainless Steel Adapters (2)	
		7" Stainless Steel Vent Termination	
		7" Stainless Steel Air Inlet	
METAL FAB			
Model	S.S. Adapter	Flue Termination	Intake Air Termination
SB 1000 - 1500	6FCGLXL	6FCGSWMC 6FCGSWC	6FCGSW90L
ICC			
SB 1000 - 1500	HE-6DSA-F	HE-6MC-F	HE-6E90-F

### 3 Sidewall direct venting

#### Vent/air termination – sidewall

**⚠ WARNING** Follow instructions below when determining vent location to avoid possibility of severe personal injury, death, or substantial property damage.

**⚠ WARNING** A gas vent extending through an exterior wall shall not terminate adjacent to a wall or below building extensions such as eaves, parapets, balconies, or decks. Failure to comply could result in severe personal injury, death, or substantial property damage.

#### Determine location

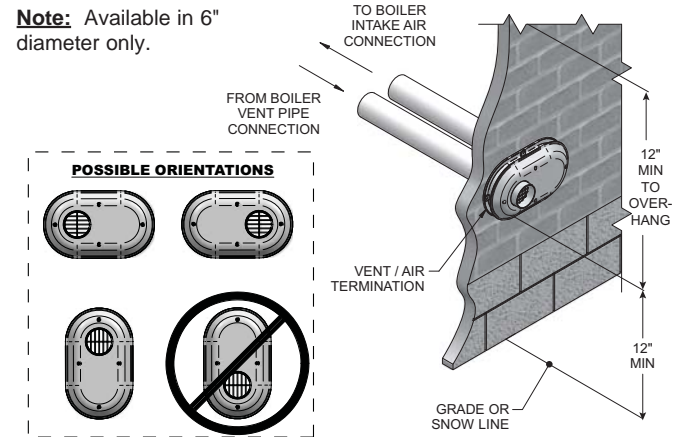
Locate the vent/air terminations using the following guidelines:

1. The total length of piping for vent or air must not exceed the limits given in the General Venting Section on page 16 of this manual.
2. You must consider the surroundings when terminating the vent and air:
  - a. Position the vent termination where vapors will not damage nearby shrubs, plants or air conditioning equipment or be objectionable.
  - b. The flue products will form a noticeable plume as they condense in cold air. Avoid areas where the plume could obstruct window views.
  - c. Prevailing winds could cause freezing of condensate and water/ice buildup where flue products impinge on building surfaces or plants.
  - d. Avoid possibility of accidental contact of flue products with people or pets.
  - e. Do not locate the terminations where wind eddies could affect performance or cause recirculation, such as inside building corners, near adjacent buildings or surfaces, window wells, stairwells, alcoves, courtyards, or other recessed areas.

**⚠ WARNING** Sidewall vent and air inlet terminations must terminate in the same pressure zone.

- f. Do not terminate above any door or window. Condensate can freeze, causing ice formations.
- g. Locate or guard vent to prevent condensate damage to exterior finishes.

**Figure 3-1A** PVC/CPVC/Centrotherm Sidewall Termination of Air and Vent



**Table 3A** CPVC/PVC Sidewall Vent Kits

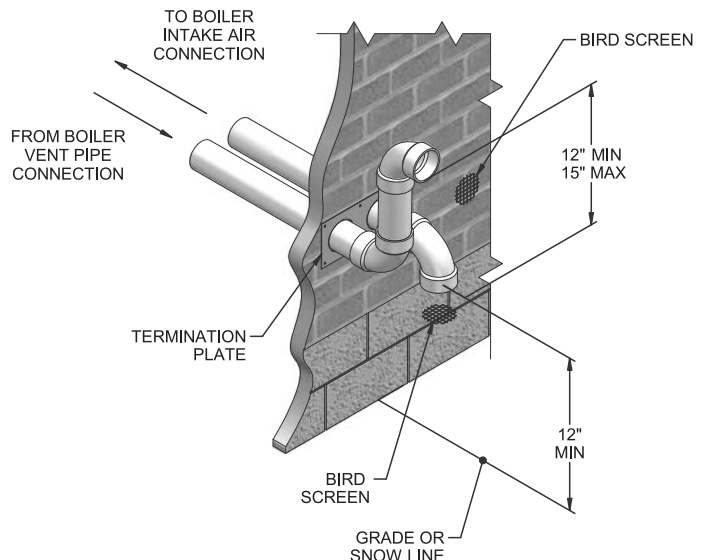
Model	Kit Number	Vent Size
1.0 - 1.5	100157612	6 inch vent

#### If using the alternate sidewall termination:

3. The air piping must terminate in a down-turned elbow as shown in FIG. 3-1B. This arrangement avoids recirculation of flue products into the combustion air stream.
4. The vent piping must terminate in an elbow pointed outward or away from the air inlet, as shown in FIG. 3-1B.

**⚠ WARNING** Do not exceed the maximum lengths of the outside vent piping shown in FIG.'s 3-1B and 3-1C. Excessive length exposed to the outside could cause freezing of condensate in the vent pipe, resulting in potential boiler shutdown.

**Figure 3-1B** Alternate Sidewall Termination of Air and Vent w/Field Supplied Fittings

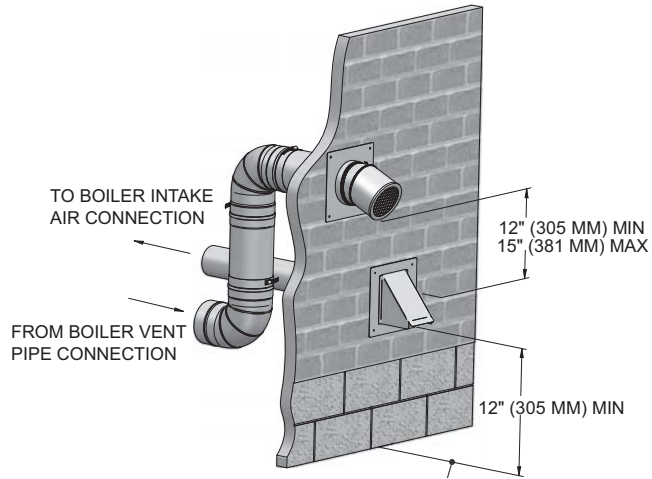


### 3 Sidewall direct venting *(continued)*

#### Vent/air termination – sidewall

**Figure 3-1C** Alternate Stainless Steel Sidewall Termination w/Field Supplied Fittings

**NOTICE** PVC/CPVC or ABS is acceptable air inlet pipe material.

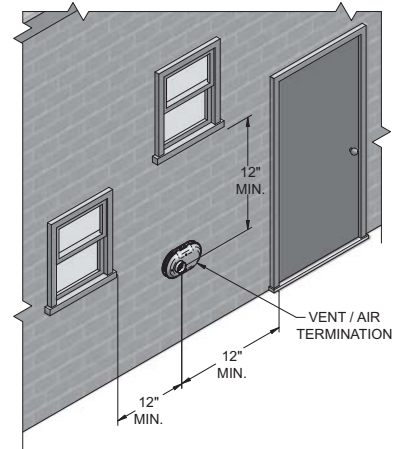


**Table 3B** Stainless Steel Sidewall Vent Kits

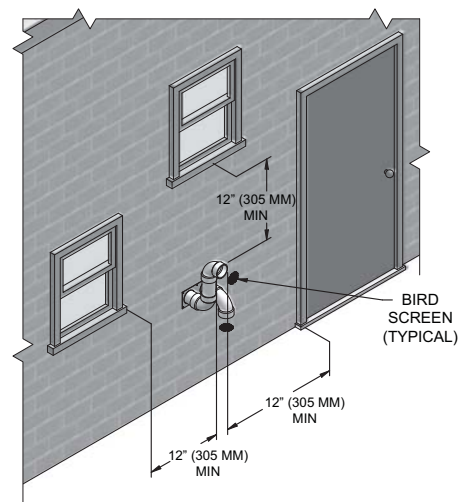
Model	Kit Number	Vent Size
1.0 - 1.5	100157602 (Stainless Steel)	6 inch vent
1.3 - 1.5	100157603 (Stainless Steel)	7 inch vent

5. Maintain clearances as shown in FIG.'s 3-1A thru 3-4B, pages 22 and 24. Also maintain the following:
  - a. Vent must terminate:
    - At least 6 feet (1.8 m) from adjacent walls.
    - No closer than 12 inches (305 mm) below roof overhang.
    - At least 7 feet (2.1 m) above any public walkway.
    - At least 3 feet (.9 m) above any forced air intake within 10 feet (3 m).
    - No closer than 12 inches (305 mm) below or horizontally from any door or window or any other gravity air inlet.
  - b. Air inlet must terminate at least 12 inches (305 mm) above grade or snow line; at least 12 inches (305 mm) below the vent termination; and the vent pipe must not extend more than 24 inches (610 mm) vertically outside the building as shown in FIG.'s 3-1B and 3-1C.
  - c. Do not terminate closer than 4 feet (1.2 m) horizontally from any electric meter, gas meter, regulator, relief valve, or other equipment. Never terminate above or below any of these within 4 feet (1.2 m) horizontally.
6. Locate terminations so they are not likely to be damaged by foreign objects, such as stones or balls, or subject to buildup of leaves or sediment.

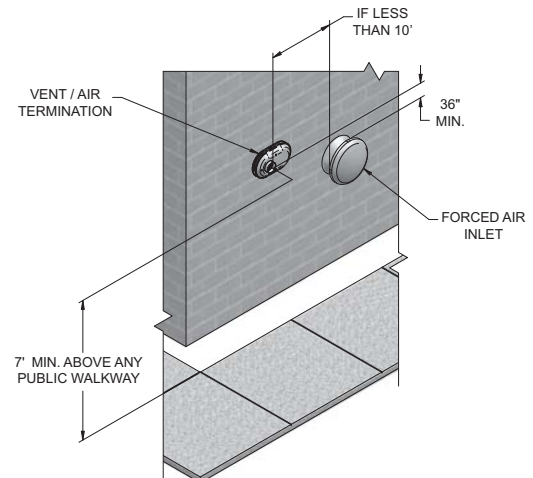
**Figure 3-2A** Clearance to Gravity Air Inlets



**Figure 3-2B** Alternate Clearance to Gravity Air Inlets w/Field Supplied Fittings

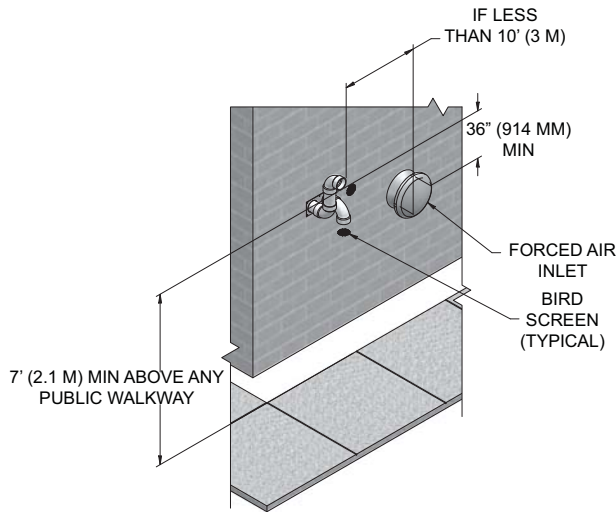


**Figure 3-3A** Clearance to Forced Air Inlets



### 3 Sidewall direct venting

**Figure 3-3B** Alternate Clearance to Forced Air Inlets w/ Field Supplied Fittings



#### Prepare wall penetrations

1. Use the factory supplied wall plate as a template to locate the vent and air intake holes and mounting holes.

##### Air pipe penetration:

- a. Cut a hole for the air pipe. Size the air pipe hole as close as desired to the air pipe outside diameter.

##### Vent pipe penetration:

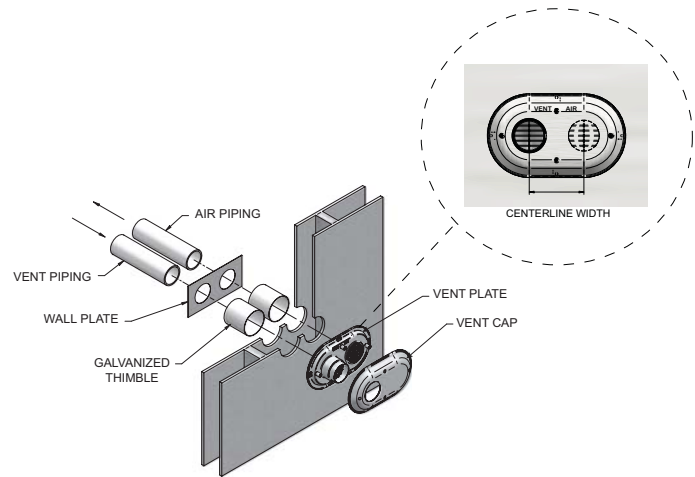
- a. Cut a hole for the vent pipe. For either combustible or noncombustible construction, size the vent pipe hole with at least a 1/2 inch clearance around the vent pipe outer diameter:
  - 7½ inch hole for 6 inch vent pipe
  - 8½ inch hole for 7 inch vent pipe

Drill 3/16" diameter holes for inserting the plastic anchors into the wall.

2. For Polypropylene Only: Install the vent and air intake sidewall adapters from Table 2E on page 20 into the vent plate. Slide the sidewall retaining bracket down the sidewall adapters flush to the vent plate (FIG. 3-4B).
3. For PVC/CPVC Only: Install the vent and air intake piping through the wall into the vent plate openings. Use RTV silicone sealant to seal the air pipe. Use the cement/primer listed in Table 2C on page 19 to seal the vent pipe.
4. Mount and secure the vent plate to the wall, using stainless steel screws.
5. Seal all gaps between the pipes and wall. Seal around the plate to the wall assuring no air gaps.
6. Assemble the vent cap to the vent plate (see FIG.'s 3-4A and 3-4B). Insert the stainless steel screws into the vent cap screw hole openings and securely attach the vent cap to the vent plate.
7. Seal all wall cavities.

8. PVC/CPVC terminations are designed to accommodate any wall thickness of standard constructions per the directions found in this manual.
9. Stainless steel terminations are designed to penetrate walls with a thickness up to 9.25 inches of standard construction.

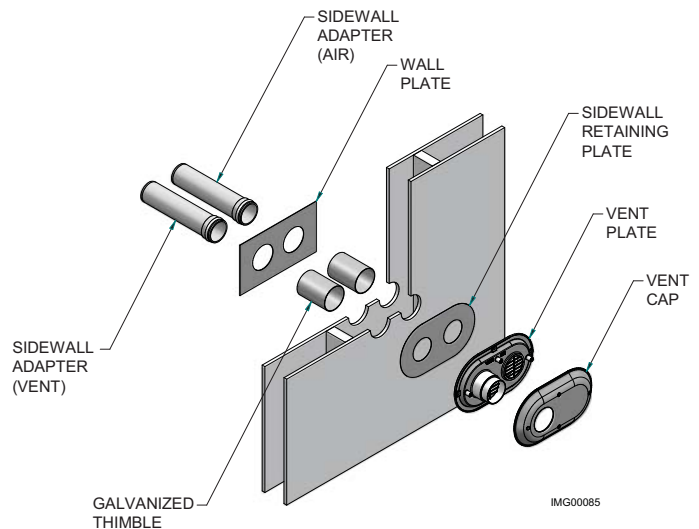
**Figure 3-4A** PVC/CPVC Sidewall Termination Assembly



**Table 3C** Sidewall Vent Centerline Dimensions

Model	Air	Vent	Centerline Width
All	6"	6"	7 3/4"

**Figure 3-4B** Polypropylene Sidewall Termination Assembly

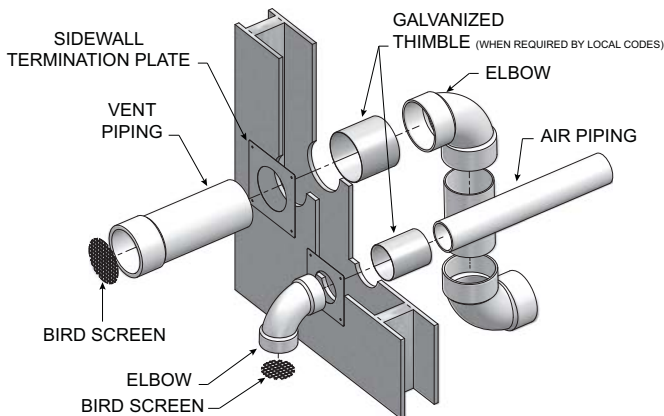


### 3 Sidewall direct venting *(continued)*

#### Prepare wall penetrations (Alternate Field Supplied Options)

1. Air pipe penetration (see FIG. 3-4B):
  - a. Cut a hole for the air pipe. Size the air pipe hole as close as desired to the air pipe outside diameter.
2. Vent pipe penetration (see FIG. 3-4B):
  - a. Cut a hole for the vent pipe. For either combustible or noncombustible construction, size the vent pipe hole with at least a 1/2 inch clearance around the vent pipe outer diameter:
    - 7½ inch (178 mm) hole for 6 inch (152 mm) vent pipe
    - 8½ inch (203 mm) hole for 7 inch (178 mm) vent pipe
  - b. Insert a galvanized metal thimble in the vent pipe hole (when required by local codes).
3. Use a sidewall termination plate as a template for correct location of hole centers.
4. Follow all local codes for isolation of vent pipe when passing through floors or walls.
5. Seal exterior openings thoroughly with exterior caulk.

**Figure 3-4C** Alternate Sidewall Termination Assembly PVC/CPVC or Stainless Steel



#### Multiple vent/air terminations

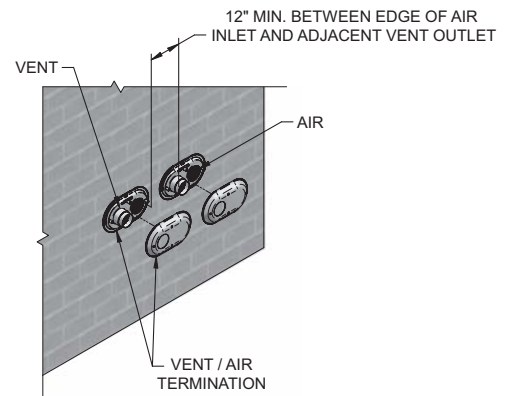
1. When terminating multiple SYNC boilers terminate each vent/air connection as described in this manual (FIG. 3-5A).

**⚠ WARNING**

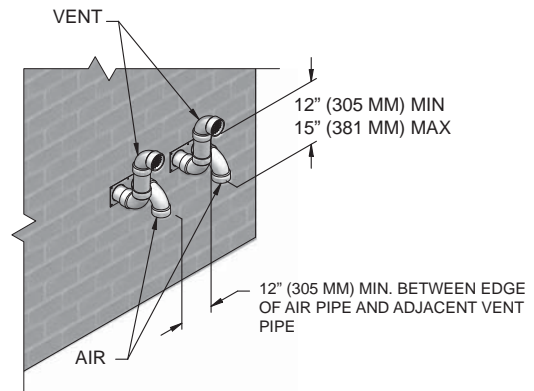
All vent pipes and air inlets must terminate at the same height to avoid possibility of severe personal injury, death, or substantial property damage.

2. Place wall penetrations to obtain minimum clearance of 12 inches (305 mm) between vent pipe and adjacent air inlet elbow, as shown in FIG. 3-5A for U.S. installations. For Canadian installations, provide clearances required by CSA B149.1 Installation Code.
3. The air inlet of a SYNC is part of a direct vent connection. It is not classified as a forced air intake with regard to spacing from adjacent boiler vents.

**Figure 3-5A** Multiple Vent Terminations (must also comply with **Figure 3-1A**)



**Figure 3-5B** Alternate Multiple Vent Terminations w/Field Supplied Fittings (must also comply with **Figure 3-1B**)



## 4 Vertical direct venting

### Vent/air termination – vertical

**WARNING** Follow instructions below when determining vent location to avoid possibility of severe personal injury, death or substantial property damage.

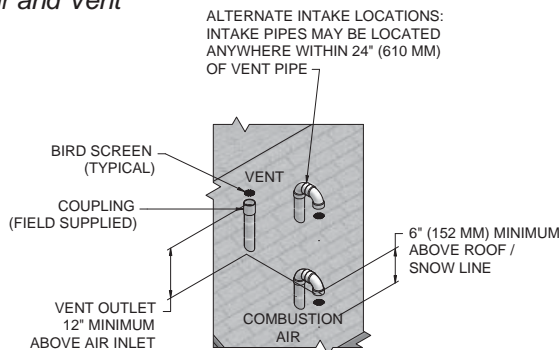
#### Determine location

Locate the vent/air terminations using the following guidelines:

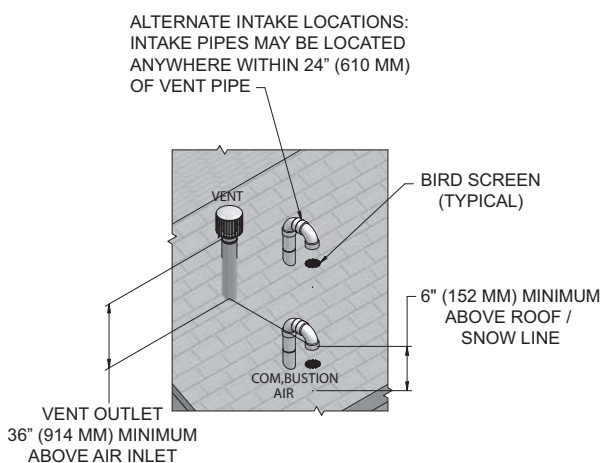
1. The total length of piping for vent or air must not exceed the limits given in the General Venting Section on page 16 of this manual.
2. Prepare the vent termination and the air termination elbow (FIG. 4-1) by inserting bird screens.
3. The vent must terminate at least 3 feet above the highest place in which the vent penetrates the roof and at least 2 feet above any part of a building within 10 horizontal feet.
4. The air piping must terminate in a down-turned 180° return pipe no further than 2 feet from the center of the vent pipe. This placement avoids recirculation of flue products into the combustion air stream.
5. The vent piping must terminate in an up-turned coupling as shown in FIG. 4-1. The top of the coupling must be at least 1 foot above the air intake. When the vent termination uses a rain cap as illustrated in FIG. 4-1 maintain at least 36" (914 mm) above the air inlet. The air inlet pipe and vent pipe can be located in any desired position on the roof, but must always be no further than 2 feet (.6 m) apart and with the vent termination at least 1 foot for PVC and 3 feet for stainless steel, above the air intake.
6. Maintain the required dimensions of the finished termination piping as shown in FIG. 4-1.
7. Do not extend exposed vent pipe outside of building more than shown in this document. Condensate could freeze and block vent pipe.

**WARNING** Rooftop vent and air inlet terminations must terminate in the same pressure zone, unless vertical vent sidewall air is set up as shown in the General Venting - Vertical Vent, Sidewall Air Section.

**Figure 4-1** PVC/CPVC/Polypropylene Vertical Termination of Air and Vent



**Figure 4-2** Stainless Steel Vertical Termination of Air and Vent



5. Locate terminations so they are not likely to be damaged by foreign objects, such as stones or balls, or subject to buildup of leaves or sediment.

#### Prepare roof penetrations

1. Air pipe penetration:
  - a. Cut a hole for the air pipe. Size the air pipe hole as close as desired to the air pipe outside diameter.
2. Vent pipe penetration:
  - a. Cut a hole for the vent pipe. For either combustible or noncombustible construction, size the vent pipe hole with at least a 1/2 inch clearance around the vent pipe outer diameter:
    - 7½ inch (178 mm) hole for 6 inch (152 mm) vent pipe
    - 8½ inch (203 mm) hole for 7 inch (178 mm) vent pipe
  - b. Insert a galvanized metal thimble in the vent pipe hole (when required by local codes).
3. Space the air and vent holes to provide the minimum spacing shown in FIG.'s 4-1 and 4-2.
4. Follow all local codes for isolation of vent pipe when passing through floors, ceilings, and roofs.
5. Provide flashing and sealing boots sized for the vent pipe and air pipe.

## 4 Vertical direct venting *(continued)*

### Multiple vent/air terminations

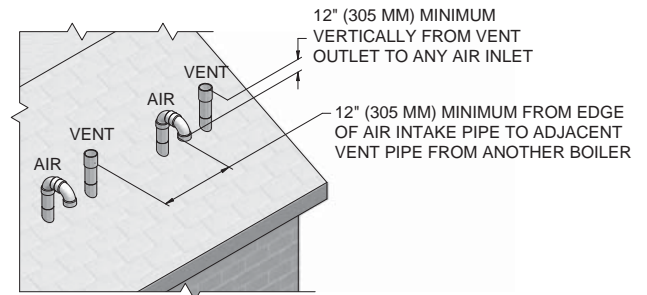
1. When terminating multiple SYNC boilers, terminate each vent/air connection as described in this manual (FIG. 4-3).

**⚠ WARNING**

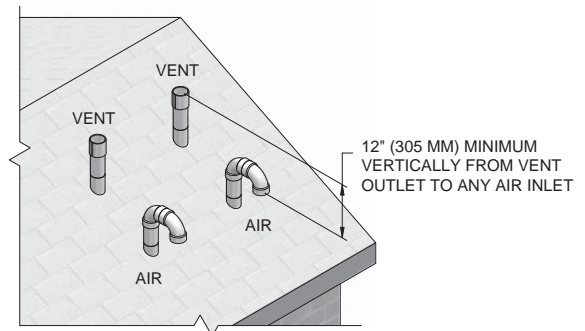
Terminate all vent pipes at the same height and all air pipes at the same height to avoid recirculation of flue products and the possibility of severe personal injury, death, or substantial property damage.

2. Place roof penetrations to obtain minimum clearance of 12 inches (305 mm) between edge of air intake elbow and adjacent vent pipe of another boiler for U.S. installations (see FIG. 4-3). For Canadian installations, provide clearances required by CSA B149.1 Installation Code.
3. The air inlet of a SYNC boiler is part of a direct vent connection. It is not classified as a forced air intake with regard to spacing from adjacent boiler vents.

**Figure 4-3** Vertical Terminations with Multiple Boilers



**Figure 4-4** Alternate Vertical Terminations with Multiple Boilers



## 5 Hydronic piping

### System water piping methods

The SYNC is designed to function in a closed loop pressurized system not less than 12 psi (83 kPa) (Non-metallic system piping must have an oxygen barrier to be considered a closed loop). A temperature and pressure gauge is included to monitor system pressure and outlet temperature and should be located on the boiler outlet.

It is important to note that the boiler has a pressure drop which must be figured in when sizing the circulators. Each boiler installation must have an air elimination device, which will remove air from the system. Install the boiler so the gas ignition system components are protected from water (dripping, spraying, etc.) during appliance operation or basic service of circulator replacement, valves, and others.

Observe a minimum of 1/4 inch (6 mm) clearance around all un-insulated hot water pipes when openings around the pipes are not protected by non-combustible materials.

### Low water cutoff device

An electronic low water cutoff is provided as standard equipment on all models. The low water cutoff should be inspected every 6 months.

### Chilled water system

If the boiler supplies hot water to heating coils in air handler units, flow control valves or other devices must be installed to prevent gravity circulation of heater water in the coils during the cooling cycle. A chilled water medium must be piped in parallel with the heater.

### Freeze protection

Freeze protection for new or existing systems must use glycol that is specially formulated for this purpose. This includes inhibitors, which prevent the glycol from attacking the metallic system components. Make certain to check that the system fluid is correct for the glycol concentration and inhibitor level. The system should be tested at least once a year and as recommended by the producer of the glycol solution. Allowance should be made for the expansion of the glycol solution in the system piping.

#### WARNING

Use only inhibited propylene glycol solutions, which are specifically formulated for hydronic systems. Ethylene glycol is toxic and can attack gaskets and seals used in hydronic systems.

### General piping information

#### **IMPORTANT**

All boiler piping must contain an oxygen barrier. This will help prevent any excess oxygen from entering the system.

Basic steps are listed below along with illustrations on the following pages (FIG.'s 5-5 and 5-6), which will guide you through the installation of the SYNC (reference FIG.s 5-1A and 5-1B).

1. Connect the system returns marked "Inlet", make sure to install with pipe sealant compound.
2. Connect the system supply marked "Outlet", make sure to install with pipe sealant compound.
3. Install purge and balance valve or shutoff valve and drain on system return to purge air out of each zone.
4. Install a backflow preventer on the cold feed make-up water line.
5. Install a pressure reducing valve on the cold feed make-up water line, (15 psi (103 kPa) nominal). Check temperature and pressure gauge (shipped separately), which should read a minimum pressure of 12 psi (83 kPa).
6. Install the circulators as shown on the piping diagrams in this section. Make sure the circulators are properly sized for the system and friction loss. Install check valves with each boiler circulator.
7. Install an expansion tank on the system supply. Consult the tank manufacturer's instruction for specific information relating to tank installation. Size the expansion tank for the required system volume and capacity.
8. Install an air elimination device on the system supply.
9. Install a drain valve at the lowest point of the system. **Note:** The boiler cannot be drained completely of water without purging the unit with an air pressure of 15 psi (103 kPa).
10. This appliance is supplied with a relief valve sized in accordance with ASME Boiler and Pressure Vessel Code, Section IV ("Heating Boilers"). The safety relief valve is installed at the factory and is located on the rear of the boiler. Pipe the discharge of the safety relief valve to prevent injury in the event of pressure relief. Pipe the discharge to a drain. Provide piping that is the same size as the safety relief valve outlet. Never block the outlet of the safety relief valve.
11. Install a field supplied strainer to prevent damage to the heat exchanger caused by debris entering from the system piping. When installing in a pre-existing system, a strainer/filter capable of removing debris left in the system is recommended.

See the piping illustrations included in this section, FIG.'s 5-5 and 5-6 for suggested guidelines in piping the SYNC.

#### **NOTICE**

Please note that these illustrations are meant to show system piping concept only, the installer is responsible for all equipment and detailing required by local codes.

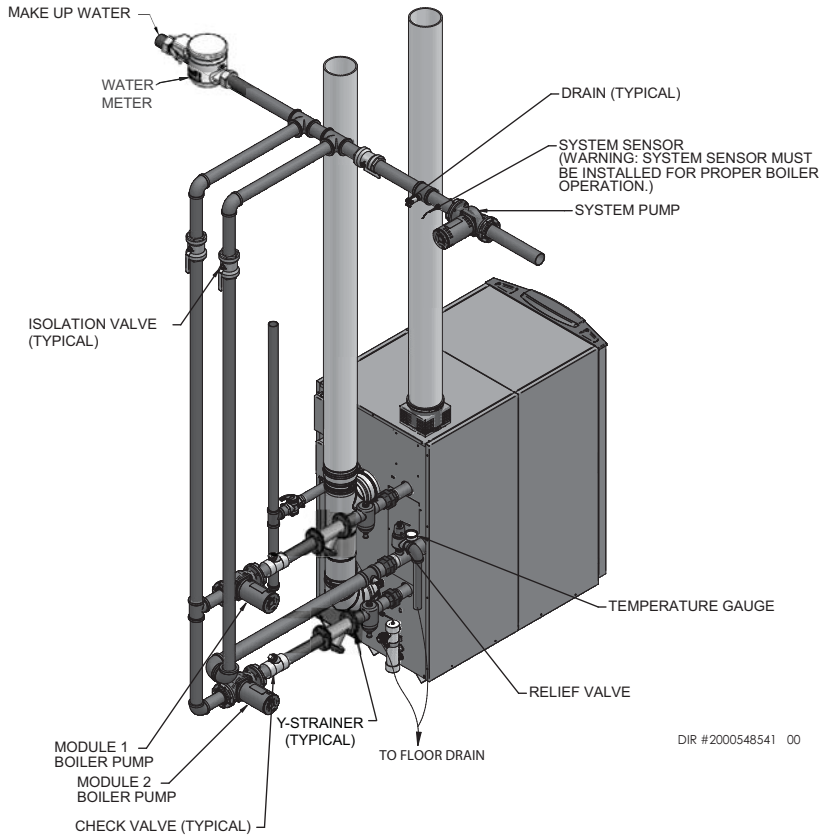
# 5 Hydronic piping *(continued)*

## Circulator sizing

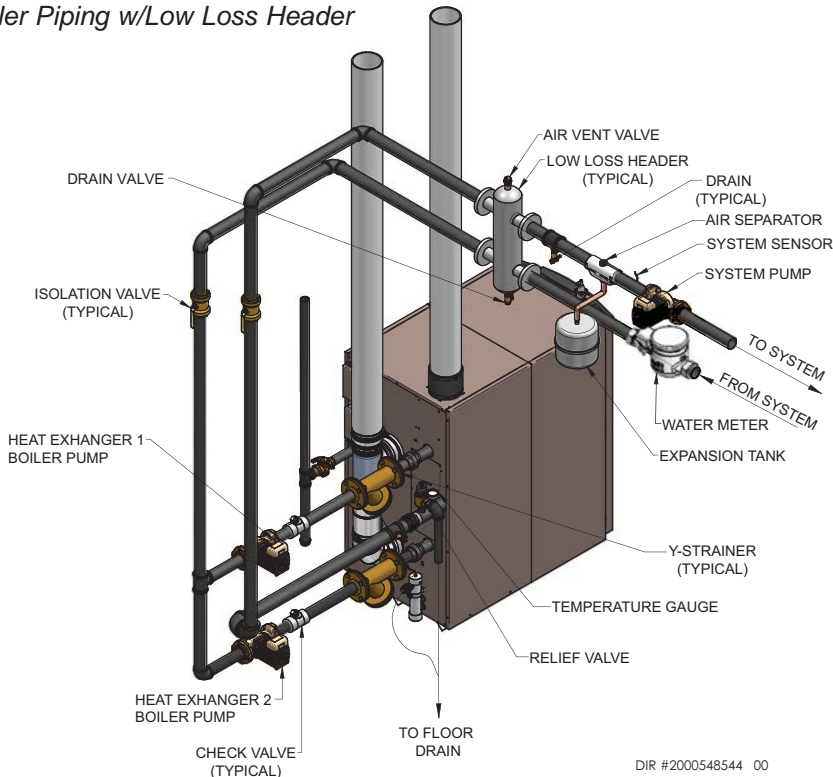
The SYNC heat exchanger does have a pressure drop, which must be considered in your system design. Refer to the graph in FIG. 5-4 for pressure drop through the SYNC heat exchanger.

## Near boiler piping connections

**Figure 5-1A** Near Boiler Piping w/Y-Strainer



**Figure 5-1B** Near Boiler Piping w/Low Loss Header



# 5 Hydronic piping

## Hot Water Generator pump sizing

The SYNC has two (2) heat exchangers that require two (2) individual pumps for proper installation in the boiler loop and an additional two (2) pumps for the Hot Water Generator loop.

Hot Water Pump Head Loss = Ft. of Head for Heat Exchanger 1 (at required flow) + Ft. of Head for the Hot Water Generator (at 2 X the flow of Heat Exchanger 1)

**Example:**

Boiler: SB1500

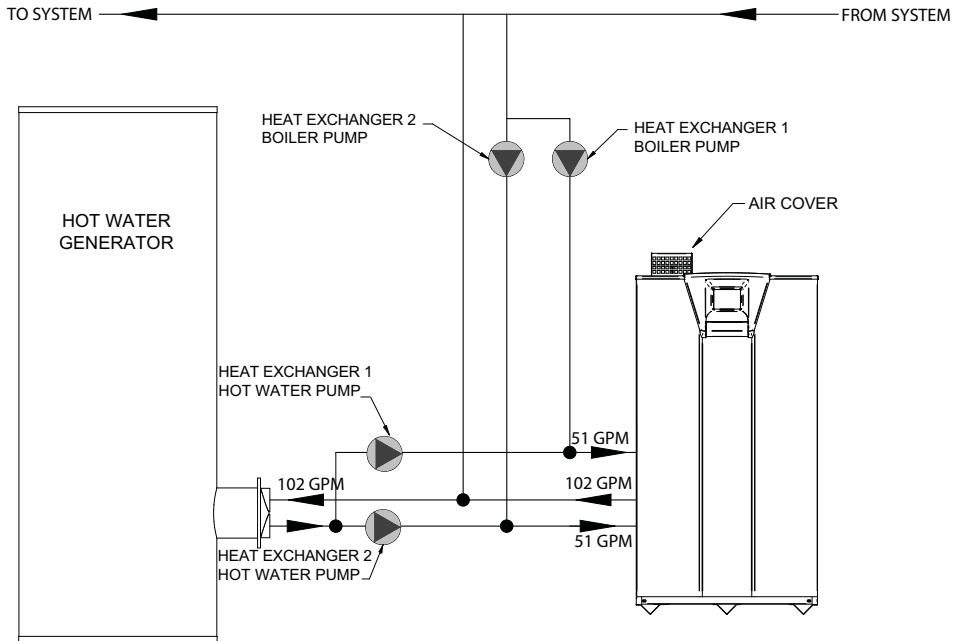
A  $\Delta T$  of 30° requires a flow through each heat exchanger of 51 GPM. The heat exchanger head loss is 18 ft. of head (see Table 5A).

Coupled with a Lochinvar Hot Water Generator with a 8-42 (diameter-length) tube bundle the calculated pressure drop is 1.2 Ft. of Head at 102 GPM.

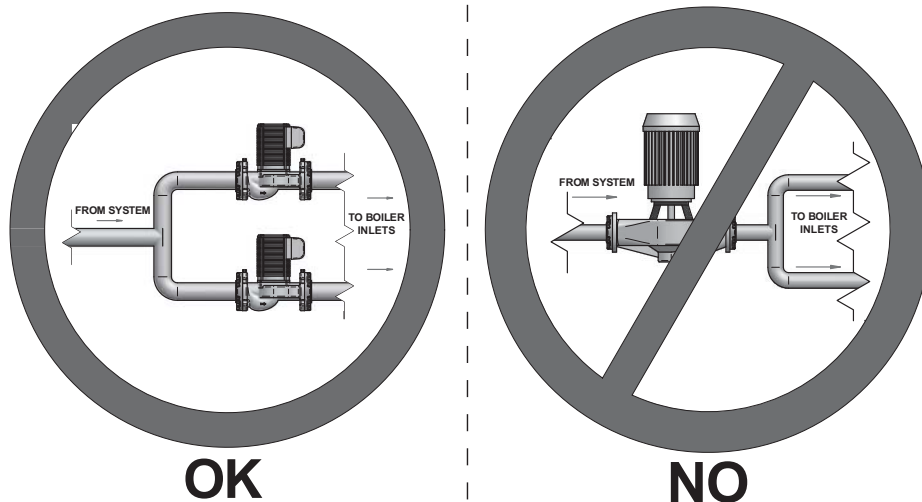
Hot Water Pump Head Loss = 18 Ft/Hd (51 GPM) + 1.2 Ft/Hd (102 GPM) = 19.2 Ft/Hd

A pump will need to be selected to flow 51 GPM with a head loss of 19.2 Ft/Hd.

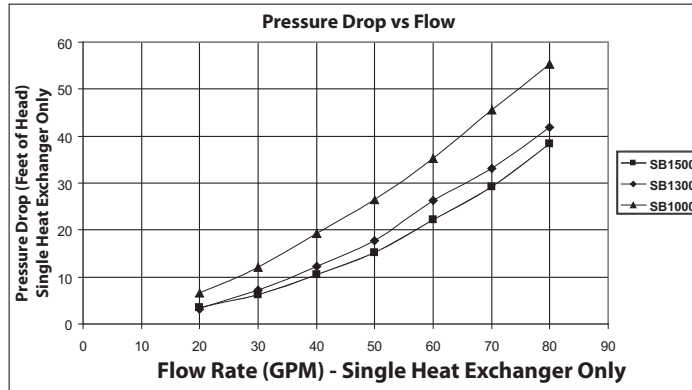
**Figure 5-2 Boiler Schematic**



**Figure 5-3 Pump Configuration**



# 5 Hydronic piping *(continued)*

**Figure 5-4 Pressure Drop vs. Flow**

**Table 5A Sizing Information for Temperature Rise Applications\_20°F, 25°F, 30°F and 35°F**

TEMPERATURE RISE APPLICATIONS									
Model	MINIMUM PIPE SIZE	20°F		25°F		30°F		35°F	
		GPM	FT/HD	GPM	FT/HD	GPM	FT/HD	GPM	FT/HD
1000	3"	55	31	40	20	38	18	32	13
1300	3"	65*	30	52	20	45	16	37	11
1500	3"	74*	33	60	23	51	18	42	12

**Note:** The information contained in this table reflects calculations for a single heat exchanger and not the combined flow and pressure drop.

**NOTICE**

Pump sizing and flow requirements are based on 20 feet (6 m) of black iron piping, 4 - 90° elbows, and 2 - fully ported ball valves.

\*When using copper with a 20° temperature rise increase piping to 3".

**NOTICE**

It is required that near boiler piping systems utilize *Primary/Secondary* configurations as shown in FIG.'s 5-5 and 5-6 only. The use of other near boiler piping configurations could result in improper building and system flow rates leading to inadvertent boiler high limit shutdowns and poor system performance.

## Near boiler piping components

### 1. Boiler piping:

Boiler system piping **MUST** be sized per the pipe requirements listed in Table 5A. Reducing the pipe size can restrict the flow rate through the boiler, causing inadvertent high limit shutdowns and poor system performance.

### 2. Boiler circulating pump:

Field supplied. The boiler circulating pump **MUST** be sized to meet the specified minimum flow requirements listed in FIG. 5-4.

### 3. Hot Water Generator circulating pump:

Field supplied. The pump **MUST** be sized to meet the specified minimum flow requirements listed in FIG. 5-4. Consult the indirect boiler operating guide to determine flow characteristics for the selected product used.

### 4. Boiler isolation valves:

Field supplied. Full port ball valves are required. Failure to use full port ball valves could result in a restricted flow rate through the boiler.

### 5. Check valves:

Field supplied. Check valves are required for installation as shown in FIG.'s 5-5 and 5-6. Failure to install check valves could result in a reverse flow condition during pump(s) off cycle.

### 6. Domestic indirect hot water isolation valves:

Field supplied. Full port ball valves are required. Failure to use full port ball valves could result in a restricted flow rate through the boiler.

### 7. Anti-scald mixing valve:

Field supplied. An anti-scald mixing valve is recommended when storing domestic hot water above 115°F (46°C).

### 8. Unions:

Field supplied. Recommended for unit serviceability.

### 9. Pressure relief valve:

Factory supplied. The pressure relief valve is sized to ASME specifications.

### 10. System temperature sensor:

Lochinvar supplies a system temperature sensor. The sensor is to be installed in the heating loop downstream from the boiler hot water piping and heating loop junction. The sensor should be located far enough downstream to sense system diluted water temperature.

### 11. Water Meter:

Field supplied. A water meter to monitor makeup water is recommended. Makeup water volume should not exceed 5% of total system per year.

**NOTICE**

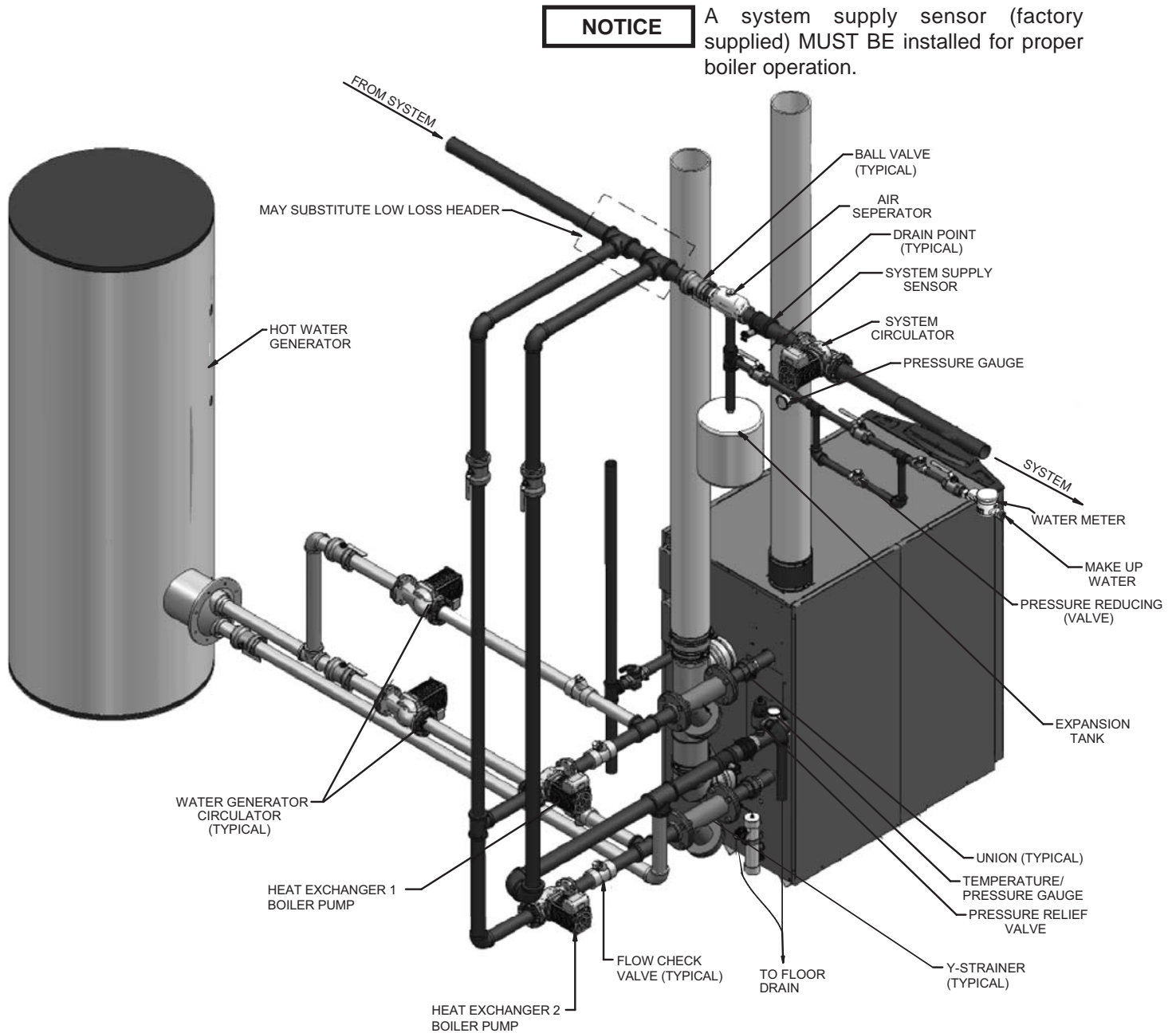
A system supply sensor (factory supplied) **MUST BE** installed for proper boiler operation.

### 12. Y-Strainer:

Field supplied. Install a Y-strainer or equivalent multi-purpose strainer just before the boiler pump at the inlet of the heat exchanger. This item is used to remove system debris from older hydronic systems and to protect newer systems.

# 5 Hydronic piping

**Figure 5-5** Single Boiler - Primary/Secondary Piping



DIR #2000548552 00

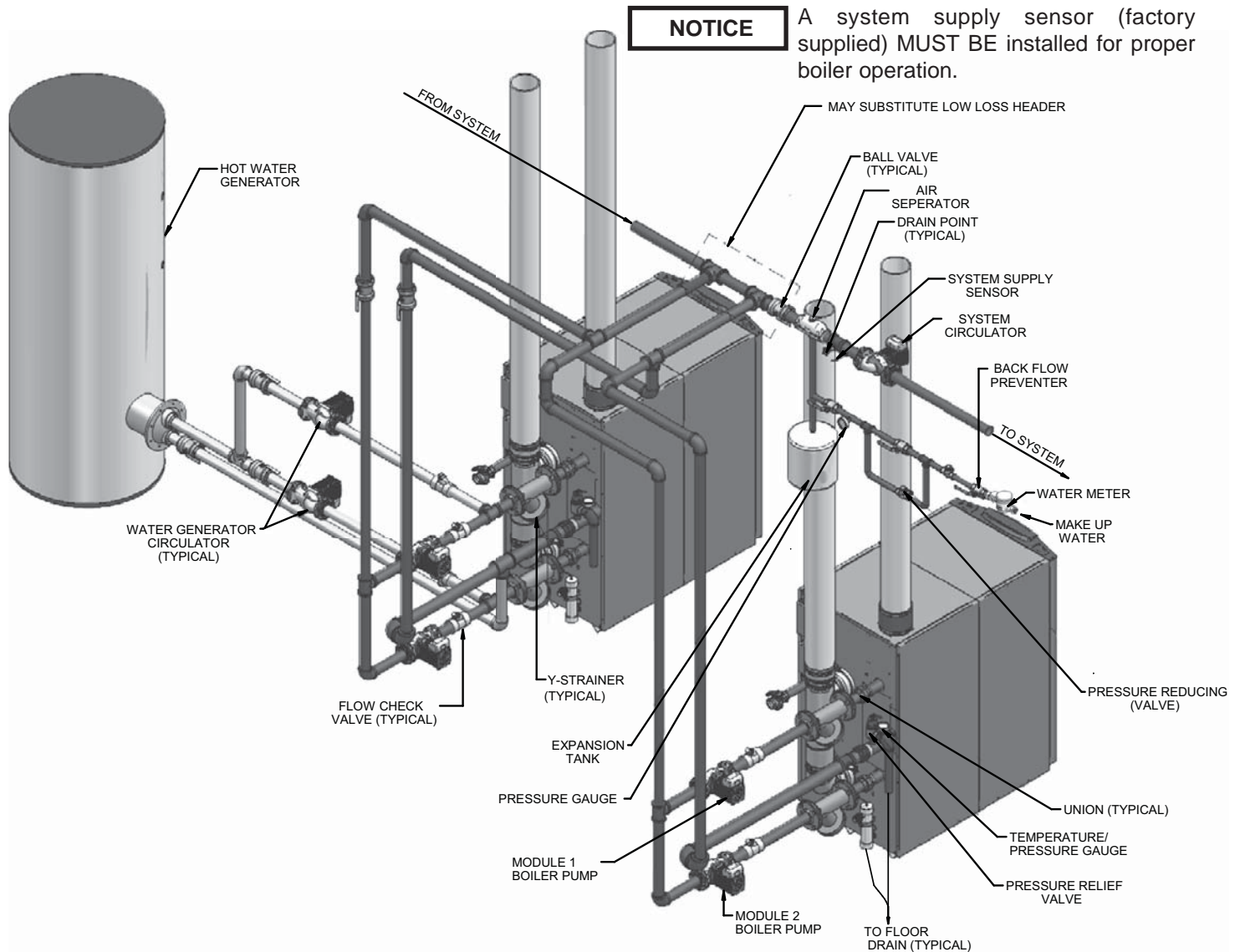
**NOTICE** Please note that these illustrations are meant to show system piping concept only, the installer is responsible for all equipment. The installer must follow all manufacturer's instructions for each system component. The installer is responsible for compliance with local codes.

**NOTICE** System flow should always remain higher than the required flow for the boiler(s) when the boiler(s) is in operation to prevent short cycling and high limit issues.

# 5 Hydronic piping *(continued)*

**Figure 5-6 Multiple Boilers - Primary/Secondary Piping**

Model	Number of Units						
	2	3	4	5	6	7	8
	Manifold Pipe Sizes in Inches (mm)						
1000	4 (102)	5 (127)	6 (152)	6 (152)	8 (203)	8 (203)	8 (203)
1300	5 (127)	5 (127)	6 (152)	8 (203)	8 (203)	8 (203)	8 (203)
1500	5 (127)	6 (152)	6 (152)	8 (203)	8 (203)	8 (203)	10 (254)



**NOTICE**

A system supply sensor (factory supplied) **MUST BE** installed for proper boiler operation.

DIR #2000548562 00

**NOTICE**

Please note that these illustrations are meant to show system piping concept only, the installer is responsible for all equipment. The installer must follow all manufacturer's instructions for each system component. The installer is responsible for compliance with local codes.

**NOTICE**

System flow should always remain higher than the required flow for the boiler(s) when the boiler(s) is in operation to prevent short cycling and high limit issues.

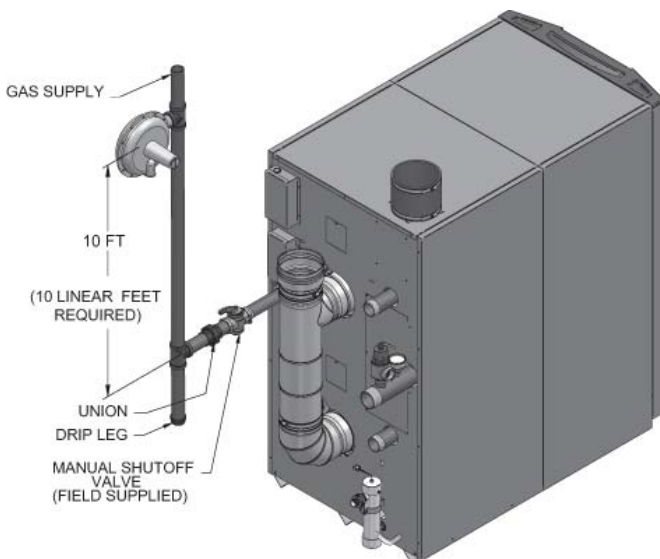
## 6 Gas connections

### Connecting gas supply piping

1. Refer to FIG. 6-1 to pipe gas to the boiler.
  - a. Install ground joint union for servicing, when required.
  - b. In Canada – When using manual main shutoff valves, it must be identified by the installer.
2. Install sediment trap / drip leg.

**Figure 6-1 Gas Supply Piping**

**⚠ WARNING** Ensure that the high gas pressure regulator is at least 10 feet (3 m) upstream of the appliance.



3. Support piping with hangers, not by the boiler or its accessories.

**⚠ WARNING**

The gas valve and blower will not support the weight of the piping. Do not attempt to support the weight of the piping with the boiler or its accessories. Failure to comply could result in severe personal injury, death, or substantial property damage.

4. Purge all air from the gas supply piping.
5. Before placing the boiler in operation, check the boiler and its gas connection for leaks.
  - a. The appliance must be disconnected from the gas supply piping system during any pressure testing of that system at a test pressure in excess of 1/2 PSIG (3.5 kPa).
  - b. The appliance must be isolated from the gas supply piping system by closing a manual shutoff valve during any pressure testing of the gas supply piping system at test pressures equal to or less than 1/2 PSIG (3.5 kPa).
  - c. The appliance and its gas connection must be leak tested before placing it in operation.

**⚠ WARNING**

Do not check for gas leaks with an open flame – use the bubble test. Failure to use the bubble test or check for gas leaks can cause severe personal injury, death, or substantial property damage.

6. Use pipe sealing compound compatible with propane gases. Apply sparingly only to male threads of the pipe joints so that pipe dope does not block gas flow.

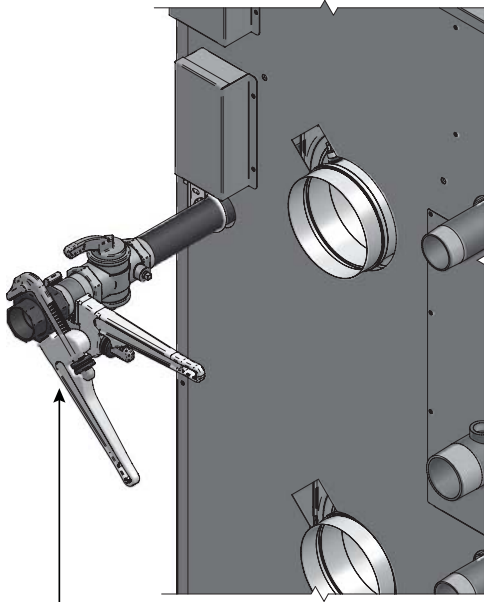
**⚠ WARNING**

Failure to apply pipe sealing compound as detailed in this manual can result in severe personal injury, death, or substantial property damage.

## 6 Gas connections *(continued)*

**⚠ WARNING** Use two wrenches when tightening gas piping at boiler (FIG. 6-2), using one wrench to prevent the boiler gas line connection from turning. Failure to support the boiler gas connection pipe to prevent it from turning could damage gas line components.

**Figure 6-2 Inlet Pipe with Backup Wrench**



USE BACK UP WRENCH TO  
PREVENT PIPE FROM ROTATING

**NOTICE** Maximum inlet gas pressure must not exceed the value specified. Minimum value listed is for the purposes of input adjustment.

### Natural gas:

**⚠ WARNING** Check boiler rating plate to determine which fuel the boiler is set for. SYNC boilers CANNOT be field converted. Failure to comply could result in severe personal injury, death, or substantial property damage.

#### Pipe sizing for natural gas

1. Refer to Table 6A for pipe length and diameter. Based on rated boiler input (divide by 1,000 to obtain cubic feet per hour).
  - a. Table 6A is only for natural gas with specific gravity 0.60 inches, with a pressure drop through the gas piping of 0.30 inches w.c.
  - b. For additional gas pipe sizing information, refer to ANSI Z223.1 (or B149.1 for Canadian installations).

#### Natural gas supply pressure requirements

1. Pressure required at the gas valve inlet pressure port:
  - Maximum 14 inches w.c. (3.5 kPa) with no flow (lockup) or with boiler on.
  - Minimum 5 inches w.c. (1.25 kPa) for 1.0 models with gas flowing (verify during boiler startup).
  - Minimum 4 inches w.c. (.99 kPa) for 1.3 - 1.5 models with gas flowing (verify during boiler startup).
2. Install 100% lockup gas pressure regulator in supply line if inlet pressure can exceed 14 inches w.c. (3.5 kPa) at any time. Adjust lockup regulator for 14 inches w.c. (3.5 kPa) maximum.

### Propane Gas:

**⚠ WARNING** Check boiler rating plate to determine which fuel the boiler is set for. SYNC boilers CAN NOT be field converted. Failure to comply could result in severe personal injury, death, or substantial property damage.

#### Pipe sizing for propane gas

1. Contact gas supplier to size pipes, tanks, and 100% lockup gas pressure regulator.

#### Propane Supply Pressure Requirements

1. Adjust propane supply regulator provided by the gas supplier for 14 inches w.c. (3.5 kPa) maximum pressure.
2. Pressure required at gas valve inlet pressure port:
  - Maximum 14 inches w.c. (3.5 kPa) with no flow (lockup) or with boiler on.
  - Minimum 8 inches w.c. (1.9 kPa) with gas flowing (verify during boiler startup).

**⚠ WARNING** Ensure that the high gas pressure regulator is at least 10 feet (3 m) upstream of the appliance.

## 6 Gas connections

**Table 6A** Natural Gas Pipe Size Chart

Capacity of Schedule 40 Metallic Pipe in Cubic Feet of Natural Gas Per Hour (based on .60 specific gravity, 0.30" w.c. pressure drop)														
Pipe Size (Inches)	Length of Pipe in Straight Feet													
	10	20	30	40	50	60	70	80	90	100	125	150	175	200
1/2	131	90	72	62	55	N/A	N/A	N/A	N/A	N/A	N/A	N/A	N/A	N/A
3/4	273	188	151	129	114	104	95	89	83	79	70	63	58	N/A
1	514	353	284	243	215	195	179	167	157	148	131	119	109	102
1 1/4	1,060	726	583	499	442	400	368	343	322	304	269	244	224	209
1 1/2	1,580	1,090	873	747	662	600	552	514	482	455	403	366	336	313
2	3,050	2,090	1,680	1,440	1,280	1,160	1,060	989	928	877	777	704	648	602
2 1/2	4,860	3,340	2,680	2,290	2,030	1,840	1,690	1,580	1,480	1,400	1,240	1,120	1,030	960
3	8,580	5,900	4,740	4,050	3,590	3,260	3,000	2,790	2,610	2,470	2,190	1,980	1,820	1,700
4	17,500	12,000	9,660	8,270	7,330	6,640	6,110	5,680	5,330	5,040	4,460	4,050	3,720	3,460

### Check inlet gas supply

**NOTICE**

CSA or UL listed flexible gas connections are acceptable, but you must exercise caution to ensure that the line has adequate capacity to allow your boiler to fire at full rate. Consult with local codes for proper installation or service procedures.

**⚠ WARNING**

DO NOT adjust or attempt to measure gas valve outlet pressure. Attempting to alter or measure the gas valve outlet pressure could result in damage to the valve, causing potential severe personal injury, death, or substantial property damage.

The gas piping must be sized for the proper flow and length of pipe, to avoid excessive pressure drop. Both the gas meter and the gas regulator must be properly sized for the total gas load.

If you experience a pressure drop greater than 1 inch w.c. (249 Pa), the meter, regulator, or gas line is undersized or in need of service. Perform the steps below when checking inlet gas supply:

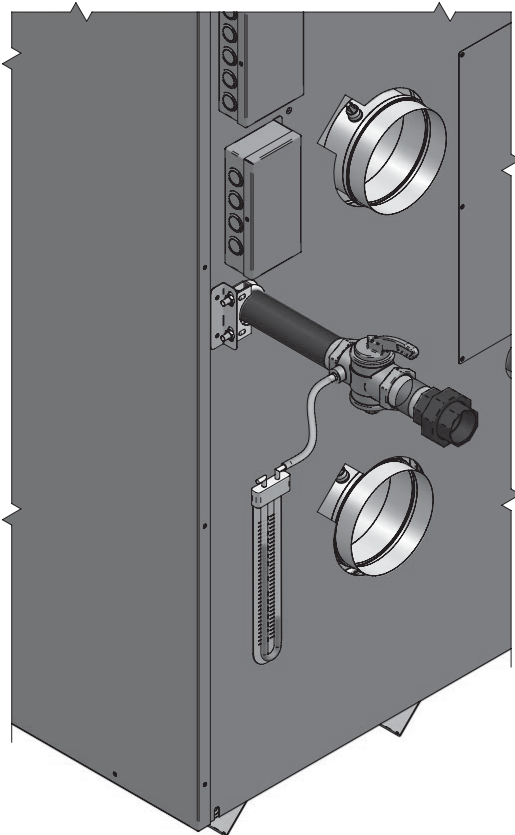
- Turn the main power switch to the "OFF" position.
- Shut off gas supply at the manual gas valve in the gas piping to the appliance.
- Remove the 1/8" pipe plug on the flange to the field supplied gas shutoff valve and install a suitable 1/8" fitting (field supplied) for the manometer tubing. Place the tubing of the manometer over the tap once the 1/8" fitting is installed as shown in FIG. 6-3.
- Slowly turn on the gas supply at the field installed manual gas valve.
- Turn the power switch to the "ON" position.
- Adjust the temperature set point on the control panel of the SMART TOUCH control module to call for heat.
- Observe the gas supply pressure as the burner fires at 100% of rated input. Percent of burner input will be displayed on the Burner Screen.
- Ensure inlet pressure is within specified range. Minimum and maximum gas supply pressures are specified in this section of the manual.
- If gas supply pressure is within normal range and no adjustments are needed, proceed on to Step 11.
- If the gas pressure is out of range, contact the gas utility, gas supplier, qualified installer or service agency to determine the necessary steps to provide proper gas pressure to the control.
- Turn the power switch to the "OFF" position.
- Shut off the gas supply at the manual gas valve in the gas piping to the appliance.
- Remove the manometer from the pressure tap on top of the gas valve. Remove the 1/8" (3 mm) field supplied fitting and reinstall the pipe plug removed in Step 3.

## 6 Gas connections *(continued)*

**⚠ WARNING** Do not check for gas leaks with an open flame -- use the bubble test. Failure to use the bubble test or check for gas leaks can cause severe personal injury, death, or substantial property damage.

14. Turn on the gas supply at the manual gas valve.
15. Turn the power switch to the “ON” position.
16. Adjust the temperature set point on the control panel of the SMART TOUCH control module to the desired water temperature so the appliance will call for heat.
17. Check burner performance by cycling the system while you observe burner response. The burner should ignite promptly. Flame pattern should be stable. Turn system off and allow burner to cool, then cycle burner again to ensure proper ignition and flame characteristics.

**Figure 6-3** Inlet Gas Supply Check



### Gas Pressure

The gas pressure must remain between 4 inches w.c. (.99 kPa) minimum (5 inches w.c. for 1.0 models) and 14 inches w.c. (3.5 kPa) maximum for Natural gas and between 8 inches w.c. (1.9 kPa) minimum and 14 inches w.c. (3.5 kPa) maximum for LP gas during standby (static) mode and while in operating (dynamic) mode. If an in-line regulator is used, it must be a minimum of 10 feet (3 m) from the SYNC boiler. It is very important that the gas line is properly purged by the gas supplier or utility company. Failure to properly purge the lines or improper line sizing, will result in ignition failure.

The problem is especially noticeable in NEW LP installations and also in empty tank situations. This can also occur when a utility company shuts off service to an area to provide maintenance to their lines.

### Gas valve replacement

The gas valve **MUST NOT** be replaced with a conventional gas valve under any circumstances. As an additional safety feature, this gas valve has a flanged connection to the venturi and blower.

**⚠ WARNING** Failure to follow all precautions could result in fire, explosion, or death!

**⚠ WARNING** DO NOT adjust or attempt to measure gas valve outlet pressure. Attempting to alter or measure the gas valve outlet pressure could result in damage to the valve, causing potential severe personal injury, death, or substantial property damage.

# 7 Field wiring

**WARNING** ELECTRICAL SHOCK HAZARD – For your safety, turn off electrical power supply before making any electrical connections to avoid possible electric shock hazard. Failure to do so can cause severe personal injury or death.

**NOTICE** Wiring must be N.E.C. Class 1.

If original wiring as supplied with boiler must be replaced, use only type 105°C wire or equivalent.

Boiler must be electrically grounded as required by National Electrical Code ANSI/NFPA 70 – latest edition.

**CAUTION** Label all wires prior to disconnection when servicing controls. Wiring errors can cause improper and dangerous operation.

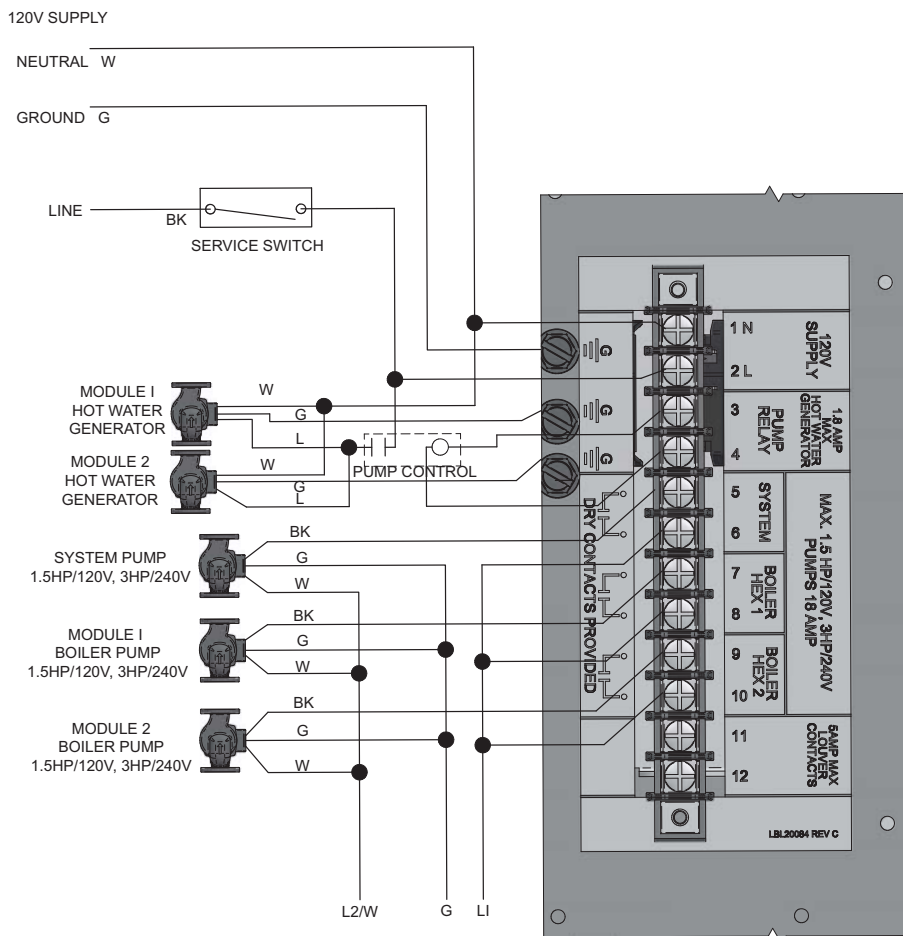
Installation must comply with:

1. National Electrical Code and any other national, state, provincial, or local codes, or regulations.
2. In Canada, CSA C22.1 Canadian Electrical Code Part 1, and any local codes.

## Line voltage connections

1. Connect 120 VAC power wiring to the line voltage terminal strip in the junction box, as shown in FIG. 7-1.
2. Provide and install a fused disconnect or service switch (15 amp recommended) as required by the code (see FIG. 7-1).
3. When connecting hot water generator pumps connect the wiring to the line voltage terminal strip as shown in FIG. 7-1. Maximum current is 1.8 amps, install a field supplied contactor.
4. To activate a system pump, wire as shown in FIG. 7-1. Dry contacts are sized for 1.5 hp/120V, 3 hp/240V or 18 amps.
5. To activate a louver, connect to the dry contacts provided. Contacts are rated for 5 amps, 120V.

Figure 7-1 Line Voltage Field Wiring Connections

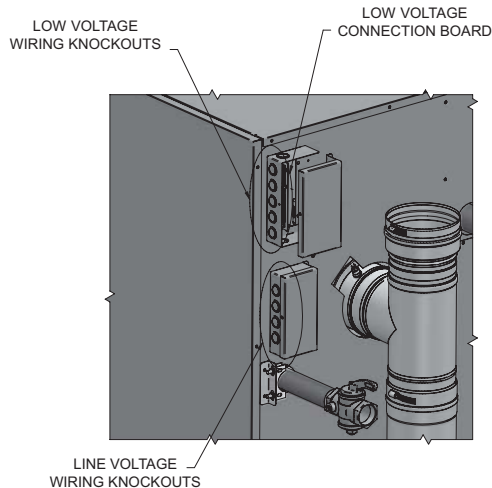


## 7 Field wiring *(continued)*

### Low voltage connections

1. Route all low voltage wires through the knockouts in the rear of the boiler, as shown in FIG. 7-2.
2. Connect low voltage wiring to low voltage connection board as shown in FIG. 7-3 on page 41 of this manual and the boiler wiring diagram.

**Figure 7-2 Routing Field Wiring**



### Enable

1. Connect the room thermostat or boiler enable contacts (isolated contact only) to terminals R and W, as shown in FIG. 7-3.
2. If a thermostat is used, install the thermostat on the inside wall away from influences of drafts, hot or cold water pipes, lighting fixtures, television, sunlight, or fireplaces.
3. Thermostat anticipator (if applicable):
  - a. If connected directly to boiler, set for 0.1 amps.
  - b. If connected to relays or other devices, set to match total electrical power requirements of connected devices. See device manufacturers' specifications and thermostat instructions for details.

### Outdoor temperature sensor

1. Connect the outdoor temperature sensor (FIG. 7-3) to the Outdoor Sensor terminals on the connection board to enable outdoor reset operation of the SYNC.
2. Mount the sensor on an exterior wall, shielded from direct sunlight or flow of heat or cooling from other sources.
3. Route sensor wires through a knockout at the rear of the boiler (see FIG. 7-2).

### Hot Water Generator (HW) thermostat

1. Connect the HW tank thermostat to the Tank Thermostat terminals on the connection board (FIG. 7-3).

### Hot Water Generator (HW) tank sensor

1. By installing a HW tank sensor, the SMART TOUCH control can perform the tank thermostat function. The SMART TOUCH control automatically detects the presence of this sensor, and generates a HW call for heat when the tank temperature drops 6°F (3°C) below the tank set point, and finishes the call for heat when the tank temperature reaches the tank set point.
2. A 100170581 sensor **MUST** be used with any indirect tank. Failure to use the correct sensor will result in the tank temperature being either above or below the set point. Connect the correct sensor to the Tank Sensor terminals (see FIG. 7-3).

### Louver proving switch

1. Louvers are used to provide combustion air for the room air option. A louver proving switch should be installed on the appropriate terminals and verified prior to operation (see FIG. 7-3).

### Flow switch (field supplied)

1. Flow switches are designed to prevent a no flow situation.
2. A flow switch may be used to guarantee flow through the boiler before allowing it to fire. When used, the SYNC boiler requires a flow switch to be installed on each inlet.
3. Remove the jumper wires from the terminals on the connection board and connect these terminals to the normally open contacts on the flow switches (FIG. 7-3).

# 7 Field wiring

## System supply sensor

1. By installing the system supply sensor into the supply of the primary loop, the temperature of the system supply can be controlled. The SMART TOUCH control automatically detects the presence of this sensor, and controls the boiler firing rate to maintain the system supply temperature to the set point.

**NOTICE**

DO NOT INSTALL THE SYSTEM SUPPLY SENSOR INTO THE SYSTEM RETURN.

2. Connect these terminals to the system supply sensor (FIG. 7-3).

**NOTICE**

A system supply sensor (factory supplied) MUST BE installed for proper boiler operation.

## Boiler management system

1. An external control may be connected to control either the firing rate or the set point of the boiler. Connect the 0 - 10 VDC terminals to the 0 - 10 VDC output of the external control. The SMART TOUCH control can be enabled using the Enable output (see page 39) or using the voltage applied to the 0 - 10 VDC input. Reference the SYNC Service Manual for more details.
2. Make sure the ground terminal is connected to the ground output terminal of the external control, and the 0 - 10 VDC terminal is connected to the 0 - 10 VDC terminal of the external control.

## Runtime contacts

The SMART TOUCH control closes a set of dry contacts whenever the burner is running. This is typically used by Building Management Systems to verify that the boiler is responding to a call for heat.

## Alarm contacts

The SMART TOUCH control closes another set of contacts whenever the boiler is locked out or the power is turned off. This can be used to turn on an alarm, or signal a Building Management System that the boiler is down. Note that these contacts will close momentarily at the end of each call for heat or at least every 24 hours.

## Wiring of the cascade

When wiring the boilers for Cascade operation, select one boiler as the Leader boiler. The remaining boilers will be designated as Members. See page 49 “Configuration of the Cascade” for a detailed explanation of this procedure.

Connect the system supply sensor and outdoor air sensor (if used) to the Leader boiler. For the Cascade system to work properly the system supply sensor must be installed.

**NOTICE**

A system supply sensor (factory supplied) MUST BE installed for proper boiler operation.

The location of the system supply sensor should be downstream of the boiler connections in the main system loop (FIG.'s 5-5 and 5-6). The system supply sensor should be wired to the Low Voltage Connection Board at the terminals marked for the system supply sensor (see FIG. 7-3). The Leader control will use the water temperature at the system supply sensor to control the operation of the Cascade.

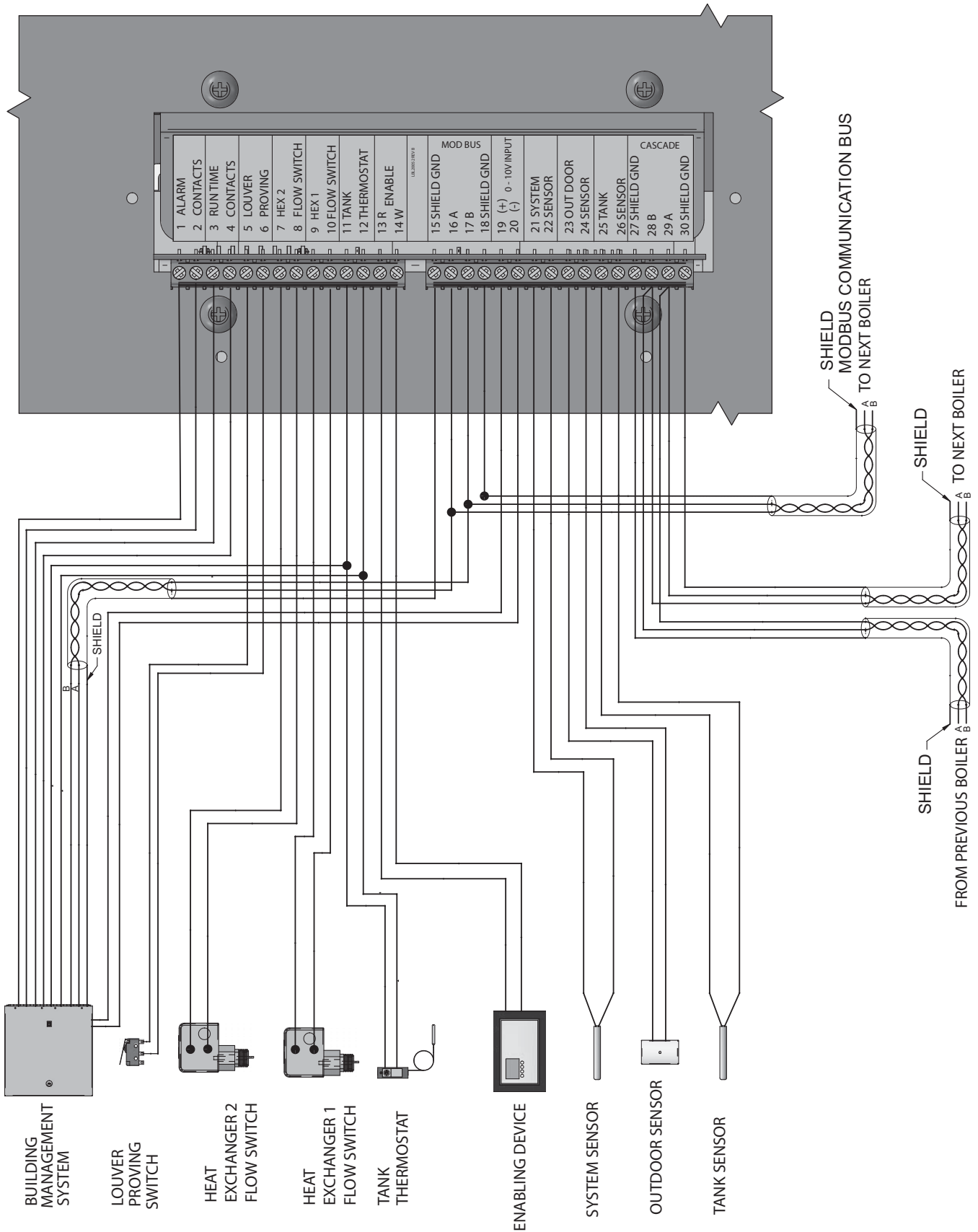
If outdoor air reset is desired, the outdoor air sensor should be wired to the Low Voltage Connection Board at the terminals marked for the outdoor air sensor on the Leader boiler (FIG. 7-3). If the outdoor air sensor is connected, the Leader control will calculate the water temperature set point based on the programmed reset curve parameters. If the outdoor air sensor is not connected, the Leader control will maintain the fixed water temperature set point that is programmed into the control.

If a Thermostat or Zone Control enable output is available, it should be wired to the Low Voltage Connection Board on the Leader boiler at the terminals marked Enable (FIG. 7-3). If the boilers are to run continuously, connect a jumper wire between the R and W terminals at the Enable input. This will initiate a call for heat on the Cascade. If the SMART TOUCH control is being controlled by a Boiler Management System (BMS), a call for heat may be initiated by the voltage applied to the 0 - 10 VDC input.

Communication between the Leader boiler and the Member boilers is accomplished by using shielded, 2-wire twisted pair communication cable. Connect one of the twisted pair wires to terminal A on each of the Low Voltage Connection boards, and the other wire of the twisted pair to terminal B on each of the Low Voltage Connection Boards. Connect the shield wires to one of the shield ground terminals on the Low Voltage Connection Boards (FIG. 7-3). If more than two boilers are on the Cascade, daisy chain the wiring from the Sequencing terminals on the second boiler to the Sequencing terminals on the third boiler, then from the third to the fourth, and so on. The connections between boilers can be made in any order, regardless of the addresses of the boilers. Try to keep each cable as short as possible.

# 7 Field wiring (continued)

Figure 7-3 Low Voltage Field Wiring Connections



# 8 Condensate disposal

## Condensate drain

1. This boiler is a high efficiency appliance that produces condensate.
2. The rear of the boiler has a 1/2 inch (12.7 mm) PVC union for connection of a 1/2 inch (12.7 mm) PVC pipe (FIG. 8-1).
3. Slope condensate tubing down and away from the boiler into a drain or condensate neutralizing filter. Condensate from the SYNC will be slightly acidic (typically with a pH from 3 to 5). Install a neutralizing filter if required by local codes.

A Neutralizer Kit (FIG. 8-1) is available from the factory.

4. Install a 1/2 inch (12.7 mm) PVC elbow (field supplied) as shown in FIG. 8-1.
5. Do not expose condensate line to freezing temperatures.

### NOTICE

Use materials approved by the authority having jurisdiction. In the absence of other authority, PVC and CPVC pipe must comply with ASTM D1785 or D2845. Cement and primer must comply with ASME D2564 or F493. For Canada use CSA or ULC certified PVC or CPVC pipe, fittings, and cement.

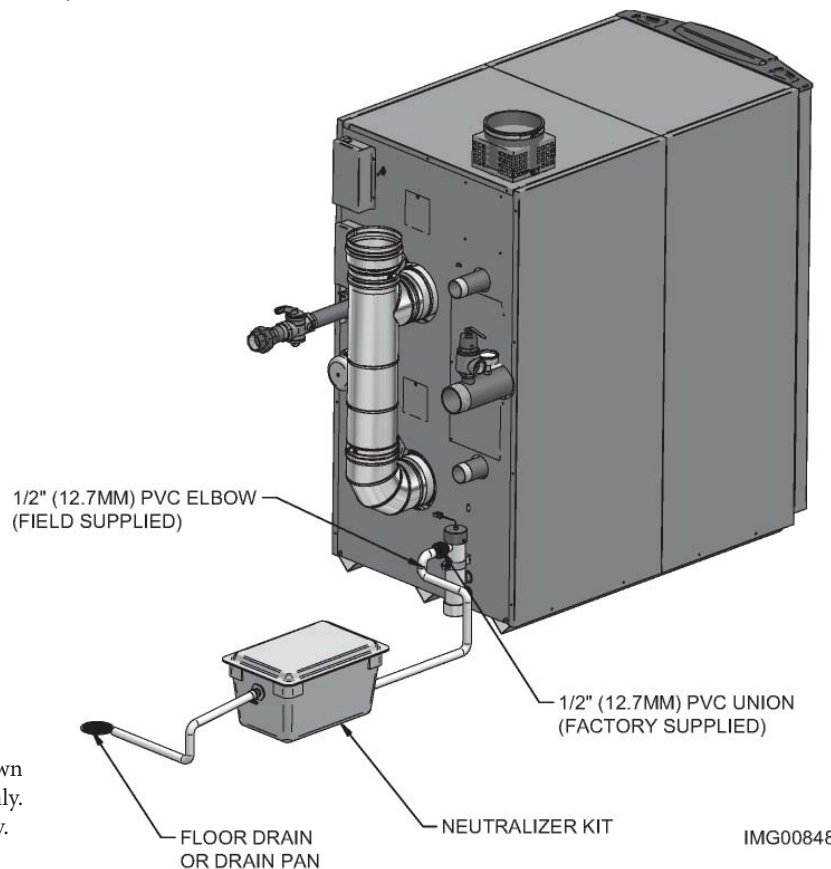
### NOTICE

To allow for proper drainage on large horizontal runs, a second line vent may be required and tubing size may need to increase to 1 inch (25 mm).

The condensate line must remain unobstructed, allowing free flow of condensate. If condensate is allowed to freeze in the line or if the line is obstructed in any other manner, condensate can exit from the boiler tee, resulting in potential water damage to property.

6. A condensate removal pump is required if boiler is below drain. When installing a condensate pump, select one approved for use with condensing boilers and furnaces. The pump should have an overflow switch to prevent property damage from condensate spillage. The switch should be wired to the auxiliary device proving switch terminals on the low voltage connection board.

**Figure 8-1** Condensate Disposal



**NOTE:** Neutralizer shown for illustrative purposes only. Actual neutralizer may vary.

IMG00848

## 9 Start-up

### Pre-Commissioning Cleaning

1. Prior to fill and start-up, flush the entire heating system.
2. Clean the entire heating system with an approved pre-commissioning cleaner (comparable to Sentinel X300 and Fernox F3) in accordance with the manufacturer's recommendation to remove debris and prolong the life of the heat exchanger.
3. Clean all water filtering devices in the system.
4. Flush the cleaning solution out of the entire system and refill.

### Fill water

#### Check/control fill water chemistry

**IMPORTANT** Conduct water quality testing prior to installing the appliance. Various solutions are available to adjust water quality.

The manufacturer recommends the following for properly filling your boiler with the appropriate water chemistry for closed loop boilers. Good fill water quality will help extend the life of the appliance by reducing the effects of lime scale buildup and corrosion in closed loop systems.

#### Hardness between 5 and 12 grains per gallon

1. Consult local water treatment companies for hard water areas (above 12 grains per gallon hardness).
2. Hardness levels that are above 12 grains/gallon can lead to lime scale buildup throughout the boiler system. If the fill water is below 5 grains/gallons, usually due to use of a water softener, it is recommended to mix in some potable water at the inlet to increase the hardness of the water to above 5 grains/gallons.

#### pH between 6.5 and 8.5

1. pH levels below 6.5 can cause an increase in the rate of corrosion. pH of 8.5 or higher can potentially cause lime scale buildup.

#### Total Dissolved Solids (TDS) less than 350 ppm

1. Total dissolved solids are all minerals, salts, metals, and charged particles that are dissolved in water.
2. The greater the amounts of TDS present, the higher the corrosion potential due to increased conductivity in the water.

#### Chloride concentration less than 150 ppm

1. Do not fill boiler or operate with water containing chlorine in excess of 150 ppm.
2. Filling with fresh drinking water should be acceptable.
3. Do not use the boiler to directly heat swimming pool or spa water.

### Boiler water

#### CAUTION

Do not use petroleum based cleaning or sealing compounds in the boiler system. Gaskets and seals in the system may be damaged. This can result in substantial property damage.

#### CAUTION

DO NOT use "homemade cures" or "boiler patent medicines". Serious damage to boiler, personnel, and/or property may result.

**Table 9A Boiler Water Chemistry**

BOILER WATER CHEMISTRY	
Specification	Range
Dissolved Solids	< 2000 ppm
pH Level	6.5 to 9.5
Chloride	< 150 ppm

- Monitoring pH, chlorides, TDS, and hardness levels can prolong the life of the appliance by reducing lime scale buildup, corrosion, and erosion. Check for leaks to ensure that fresh water is not entering the system.
- Continual fresh makeup water will reduce boiler life.
- Mineral buildup in the heat exchanger reduces heat transfer, overheats the stainless steel heat exchanger, and causes failure.
- The addition of oxygen carried in by makeup water can cause internal corrosion in system components.
- Leaks in the boiler or piping must be repaired at once to prevent excessive makeup water. For this purpose, it is recommended to install a water meter to easily check the amount of makeup water entering the system. Makeup water volume should not exceed 5% of the total system volume per year. **NOTE:** When makeup water is added, make sure the chemical additives are added to maintain the correct level.
- An approved multi-metal corrosion inhibitor (comparable to Sentinel X100 or Fernox F1) is recommended at the correct concentration and in the manner recommended by the manufacturer.

### Freeze protection

#### WARNING

Ethylene glycol is toxic, DO NOT use as your freeze protection. Ethylene glycol has a sweet aroma which children and pets could mistake as food and ingest; leading to death.

1. Use glycol only if needed for freeze protection.
2. Propylene glycol is the recommended freeze protection.
3. Make sure to flush the boiler system before adding glycol.
4. Determine the freeze protection fluid quantity using system water content, following the fluid manufacturer's instructions. Boiler water content is listed on page 6. Remember to include expansion tank water content.

## 9 Start-up

5. Local codes may require a backflow preventer or actual disconnect from city water supply.
6. When using freeze protection fluid with automatic fill, it is suggested to install a water meter to monitor water makeup. Freeze protection fluid may leak before the water begins to leak, causing the concentration to drop, which reduces the freeze protection level.
7. The freeze protection set points may be lowered when freeze protection fluid is used (see the SYNC Service Manual).
8. Consult the glycol manufacturer for details on the suggested mix of glycol and water for the desired freeze protection level and the de-rate effect it will have on the boiler output.

### Test / replace freeze protection fluid

1. For systems using freeze protection fluids, follow the fluid manufacturer's instructions.
2. Freeze protection fluid must be replaced periodically due to degradation of inhibitors over time.
3. It is recommended to test the glycol concentration annually and adjust within the desired set points.

## Oxygen prevention

### CAUTION

Eliminate all system leaks. Continual fresh makeup water will reduce boiler life. Minerals can build up in the heat exchanger, reducing heat transfer, overheating the heat exchanger, and causing heat exchanger failure.

Dissolved oxygen can have a negative effect on the boiler system. Oxygen can cause iron oxide to generate iron deposits. Oxygen may also increase the rate of corrosion on non-stainless steel parts of the system. A low pH level combined with oxygen further enhances its corrosive effects. After boiler installation, check for air leaks in the following areas:

- Suction gasket
- Pump
- Air valve
- O-ring gaskets

Precautions include installing a water meter to evaluate the fresh water volume entering the system (should be no more than 5% system volume). Additional volumes of fresh water could indicate that a leak is present.

### Fill and test water system

1. Fill system only after ensuring the water meets the requirements of this manual.
2. Close automatic and manual air vents and boiler drain valve.
3. Fill to correct system pressure. Correct pressure will vary with each application.
  - a. The minimum cold water fill pressure for a system is 12 psi.
  - b. Pressure will rise when the boiler is turned ON and system water temperature increases.
4. At initial fill and during boiler startup and testing, check the system thoroughly for any leaks. Repair all leaks before proceeding further.

### Purge air from water system

1. Purge air from system:
  - a. Connect a hose to the purge valve (see purge/drain valve in the piping diagrams on pages 42 through 47). Route the hose to an area where water can drain and be seen.
  - b. Close the boiler or system isolation valve between the purge valve and fill connection to the system.
  - c. Close zone isolation valves.
  - d. Open the quick-fill valve on the cold water makeup line.
  - e. Open purge valve.
  - f. Open the isolation valves one zone at a time. Allow water to run through the zone, pushing out the air. Run until no noticeable air flow is present. Close the zone isolation valves and proceed with the next zone. Follow this procedure until all zones are purged.
  - g. Close the quick-fill water valve and purge valve and remove the hose. Open all isolation valves. Watch that system pressure rises to correct cold-fill pressure.
  - h. After the system has operated for a while, eliminate any residual air by using the manual air vents located throughout the system.
  - i. If purge valves are not installed in the system, open the manual air vents in the system one at a time, beginning with the lowest floor. Close the vent when water squirts out. Repeat with remaining vents.
2. Open the automatic air vent (diaphragm-type or bladder type expansion tank systems only) one turn.
3. Open other vents:
  - a. Starting on the lowest floor, open air vents one at a time until water squirts out.
  - b. Repeat with remaining vents.
4. Refill to correct pressure.

## 9 Start-up *(continued)*

### Check for gas leaks

#### **⚠ WARNING**

Before starting the boiler, and during initial operation, smell near the floor and around the boiler for gas odorant or any unusual odor. Remove the top access panel and smell the interior of the boiler enclosure. Do not proceed with startup if there is any indication of a gas leak. Use an approved leak detection solution. Repair any leaks at once.

#### **⚠ WARNING**

DO NOT adjust or attempt to measure gas valve outlet pressure. The gas valve is factory set for the correct outlet pressure. This setting is suitable for natural gas and propane, requiring no field adjustment. Attempting to alter or measure the gas valve outlet pressure could result in damage to the valve, causing potential severe personal injury, death, or substantial property damage.

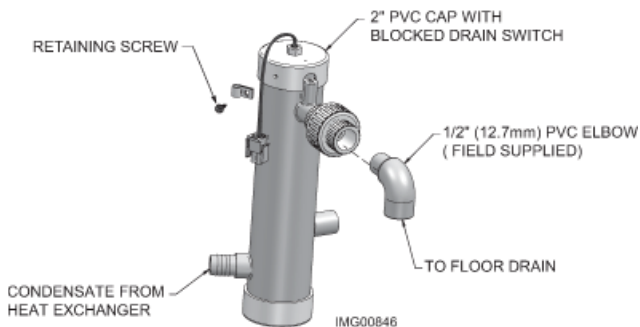
#### **⚠ WARNING**

Propane boilers only – Your propane supplier mixes an odorant with the propane to make its presence detectable. In some instances, the odorant can fade, and the gas may no longer have an odor. Before startup (and periodically thereafter), have the propane supplier verify the correct odorant level in the gas.

### Check thermostat circuit(s)

1. Disconnect the two external wires connected to the enable terminals on the connection board.
2. Connect a voltmeter across these two incoming wires. Close each thermostat, zone valve, and relay in the external circuit one at a time and check the voltmeter reading across the incoming wires.
3. There should NEVER be a voltage reading.
4. If a voltage does occur under any condition, check and correct the external wiring. (This is a common problem when using 3-wire zone valves.)
5. Once the external boiler enable wiring is checked and corrected if necessary, reconnect the external thermostat circuit wires to the connection board. Allow the boiler to cycle.

**Figure 9-1** Condensate Trap



### Inspect/fill condensate system

#### Inspect/check condensate lines and fittings

1. Inspect the condensate drain line, condensate PVC fittings and condensate trap.

#### Fill condensate trap with water

1. Remove the PVC cap retaining screw from the PVC cap (FIG. 9-1).
2. Remove the 2 inch PVC cap with the switch located at the top of the trap (FIG. 9-1).
3. Fill with fresh water until the water begins to pour out of the drain.
4. Replace the cap. Press the cap onto the trap until the cap makes contact with the drain.
5. Replace the retaining screw.

#### **⚠ WARNING**

The condensate trap (FIG. 9-1) must be filled with water during all times of boiler operation to avoid flue gas emission from the condensate drain line. Failure to fill the trap could result in severe personal injury or death.

## 9 Start-up

### Final checks before starting the boiler

- ❑ Read the SYNC Service Manual to familiarize yourself with SMART TOUCH control module operation. Read this manual, page 47 for proper steps to start boiler.
- ❑ Verify the boiler and system are full of water and all system components are correctly set for operation.
- ❑ Verify the preparation procedures of Section 9, pages 44 and 45 have been completed.
- ❑ Fill the vent condensate trap with water (removing the retaining screw in order to remove the 2 inch (50.8 mm) PVC cap with the switch located at the top of the trap). Replace the cap. Press the cap onto the trap until the cap makes contact with the drain. Replace the retaining screw.
- ❑ Verify electrical connections are correct and securely attached.
- ❑ Inspect vent piping and air piping for signs of deterioration from corrosion, physical damage or sagging. Verify air piping and vent piping are intact and correctly installed per this manual.

### Start the boiler

1. Read and follow the Operating instructions in FIG. 9-2, page 47.

### If boiler does not start correctly

1. Check for loose connections, blown fuse or service switch off?
2. Is external limit control (if used) open? Is boiler water temperature above 200°F (93°C)?
3. Is thermostat set below room temperature?
4. Is gas turned on at meter or boiler?
5. Is incoming gas pressure less than 4 inches w.c. (.99 kPa)?

If none of the above corrects the problem, refer to the Troubleshooting Section of the SYNC Service Manual.

### Check system and boiler

#### ❑ Check water piping

1. Check system piping for leaks. If found, shut down the boiler and repair immediately. (See WARNINGS on pages 43 through 45 (startup) regarding failure to repair leaks.)
2. Vent any remaining air from the system using manual vents. Air in the system will interfere with circulation and cause heat distribution problems and noise.

#### ❑ Check vent piping and air piping

1. Check for gastight seal at every connection, seam of air piping, and vent piping.

#### WARNING

Venting system must be sealed gastight to prevent flue gas spillage and carbon monoxide emissions, which will result in severe personal injury or death.

#### ❑ Check gas piping

1. Check around the boiler for gas odor following the procedure on page 34 of this manual (connecting gas supply piping).

#### WARNING

If you discover evidence of any gas leak, shut down the boiler at once. Find the leak source with a bubble test and repair immediately. Do not start the boiler again until corrected. Failure to comply could result in severe personal injury, death, or substantial property damage.

### Check flame and combustion

1. Turn the main power off to the boiler by placing the “On/Off” switch in the OFF position.
2. Remove the flue temperature sensors from the flue pipe connections. **Note:** Combustion measurements will be made at this point.
3. Turn the main power on to the boiler by placing the “On/Off” switch in the ON position.

## 9 Start-up *(continued)*

**Figure 9-2** Operating Instructions

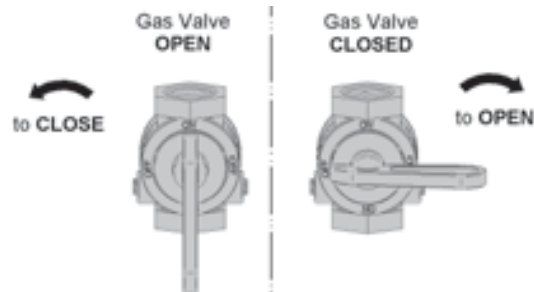
### FOR YOUR SAFETY READ BEFORE OPERATING

**WARNING:** If you do not follow these instructions exactly, a fire or explosion may result causing property damage, personal injury, or loss of life.

- A. This appliance does not have a pilot. It is equipped with an ignition device which automatically lights the burner. Do not try to light the burner by hand.
  - B. BEFORE OPERATING smell all around the appliance area for gas. Be sure to smell next to the floor because some gas is heavier than air and will settle on the floor.
- WHAT TO DO IF YOU SMELL GAS**
- Do not try to light any appliance.
  - Do not touch any electric switch; do not use any phone in your building.
  - Immediately call your gas supplier from a neighbor's phone. Follow the gas supplier's instructions.
  - If you cannot reach your gas supplier, call the fire department.
- C. Use only your hand to turn the gas control knob. Never use tools. If the handle will not turn by hand, don't try to repair it, call a qualified service technician. Force or attempted repair may result in a fire or explosion.
  - D. Do not use this appliance if any part has been under water. Immediately call a qualified service technician to inspect the appliance and to replace any part of the control system and any gas control which has been under water.

### OPERATING INSTRUCTIONS

1. **STOP!** Read the safety information above on this label.
2. Set the thermostat to lowest setting.
3. Turn off all electric power to the appliance.
4. This appliance is equipped with an ignition device which automatically lights the burner. Do not try to light the burner by hand.
5. Remove front door.
6. Turn gas shutoff valves counterclockwise to "OFF". Handle will be perpendicular to pipe. Do not force.
7. Wait five (5) minutes to clear out any gas. If you then smell gas, **STOP!** Follow "B" in the safety information above this label. If you don't smell gas, go to next step.
8. Turn gas shutoff valve clockwise to "ON". Handle will be parallel to pipe.
9. Install top cover.
10. Turn on all electric power to appliance.
11. Set thermostat to desired setting.
12. If the appliance will not operate, follow the instructions "To Turn Off Gas To Appliance" and call your service technician or gas supplier.



### TO TURN OFF GAS TO APPLIANCE

1. Set the thermostat to lowest setting.
2. Turn off all electric power to the appliance if service is to be performed.
3. Remove front door.
4. Turn gas shut off valves counterclockwise to "OFF". Handle will be perpendicular to pipe. Do not force.
5. Install front door.

LBL20053 REVA

## 9 Start-up

### Check flame and combustion *(continued)*

- Navigate to the Service Mode Screen from the Status Screen by pressing the MAIN button and then the SERVICE MODE button.
- On the Service Screen place Heat Exchanger 1 into operation by selecting Heat Exchanger 1 with the SELECT button and turning the heat exchanger on by pressing the ON/OFF button (OFF indicates that the heat exchanger is off and ON indicates that the heat exchanger should be firing).
- Insert the probe from a combustion analyzer into the hole left by the removal of the flue temperature sensor.

**Note:** Heat Exchanger 1 is the top heat exchanger; please ensure the probe is in the top flue sensor location.

- Once the heat exchanger has modulated up to full fire measure the combustion. The values should be in the range listed in Table 9A below. CO levels should be less than 200 ppm for a properly installed unit. If the combustion is not within range reference the *Troubleshooting* Section in the SYNC Service Manual for possible causes and corrective actions.

**Table 9A Flue Products Chart**

Natural Gas		Propane	
CO <sub>2</sub>	O <sub>2</sub>	CO <sub>2</sub>	O <sub>2</sub>
8.0% - 10%	3.0% - 6.5%	9.0% - 11%	4.1% - 6.9%

- Once the Heat Exchanger 1 analysis is complete, test the safety shutoff device by turning the manual shutoff valve to the OFF position and ensuring that Heat Exchanger 1 shuts down and registers an alarm. Open the manual shutoff valve, reset the control, and return to Service Mode.
- Repeat the same procedure for Heat Exchanger 2 by selecting Heat Exchanger 2 while on the Service Mode Screen. Be certain to insert the probe from the combustion analyzer into the Heat Exchanger 2 flue temperature sensor location.
- Turn the main power off to the boiler and replace the flue temperature sensor into the flue pipe connection.
- Place the boiler back into normal operation.

#### WARNING

You must replace the flue gas temperature sensor to prevent flue gas spillage into the room. Failure to comply could result in severe personal injury, death, or substantial property damage.

### Set space heating operation

#### Verify space heat circulator mode

The Space Heating Mode controls the system pump (if connected), and both boiler pumps. When the SMART TOUCH control receives a space heating call for heat, it turns on the system pump. If the boiler is not heating an indirect HW (Hot Water) tank, it also turns on the boiler pump. After the space heating call for heat ends, the system pump continues to run for a short period of time. If the boiler pump was running, it continues to run for a short period of time as well. These pump delays are factory set to 30 seconds. If different delays are desired, the appropriate parameters in the control must be changed. See the SYNC Service Manual for a detailed explanation of this procedure.

#### Set space heating set point temperature

During normal operation, space heating set point temperatures can be adjusted from the Set Points Menu. Press the following buttons to navigate to the Set Points Menu from the Status Screen:



- To change a set point, press the SELECT button next to the user set point parameter.
- The first time the user set point parameter is accessed, you will be required to enter the user password. The user password is 0704.
- Using the keypad, enter the password and then press the OK button. If the password is not entered correctly, the screen will revert to the Parameter List Screen and you will not be able to adjust the set point. If a digit has been entered incorrectly, press the left arrow key on the keypad to back the digit up. If the password has been entered correctly, the Parameter Change Screen will appear. The Parameter Change Screen will display the set point being changed, the previous setting of the set point, and adjustment buttons.
- To adjust the set point, press the + or - buttons to change the value being displayed.
- Once the set point has been adjusted to the desired setting press the APPLY button to change the set point and return to the Parameter List Screen.

## 9 Start-up *(continued)*

6. If no other changes are necessary, press the BACK button to return to the Parameter List Screen.
7. Once all the necessary adjustments have been made, press the BACK button to return to the Setup Screen.
8. Press the SAVE button to program all changes made to the set points and return to the Status Screen. Leaving the Setup Screen without pressing the SAVE button will erase the changes made to the set points and change them back to their previous settings.

**Note:** The SAVE button must be pressed to ensure proper programming of the controls. Failure to press the SAVE button will require all changes to be reprogrammed.

### Set Hot Water Generator (HW) operation

#### Verify HW circulator mode

The HW Mode is programmed to heat an indirect hot water tank. When a tank thermostat or a tank sensor initiates a call for heat, the SMART TOUCH control will turn on the HW pumps and turn off the boiler pumps (if running). If the system pump is running, it will remain on. When the HW call for heat ends, and there is no space heating call for heat, the HW pumps will continue to run for a period of time. This pump delay is set at the factory to 30 seconds. If a shorter or longer delay is desired, the appropriate parameter in the control must be changed. See the SYNC Service Manual for a detailed explanation of this procedure. If there is an active space heating call for heat, then the boiler pumps will be turned on and the HW pumps will be turned off.

#### Set HW target temperature

When in the HW Mode, the control will modulate to maintain the outlet temperature to a set point. This set point is set at the factory to 180°F. If a different set point is desired, the appropriate parameter in the control must be changed. See the SYNC Service manual for a detailed explanation of this procedure.

#### Set clock

To program the clock, access the night setback parameter by pressing the following buttons:



The SMART TOUCH control has a built-in clock that it uses for its night setback feature and for logging events. This clock must be set when the boiler is installed, and anytime the boiler has been powered off for more than one month. Use the following procedure to set the clock:

1. To set the clock, press the SELECT button in the upper right-hand corner of the display. The date and time are displayed as “Day dd/mm/yy hh:mm”. Day = day of the week (1 = Monday, 2 = Tuesday, etc.), dd = date, mm = month, yy = year, hh = hour, mm = minutes (24 hour time; 2:30PM = 14:30).

2. Using the keypad, adjust the date and time by working from left to right. If a digit has been entered incorrectly, press the left arrow key on the keypad to back the digit up. If no change is necessary, press the BACK button to return to the Parameter List Screen. Once the correct date and time have been entered press the OK button on the display to program the date and time into memory and return to the Parameter List Screen.

#### NOTICE

The internal clock does not adjust for Daylight Savings Time and therefore, will require a manual adjustment.

#### Configuration of the cascade

When installed in a Cascade system, the individual controls must be programmed for cascade operation. To program the cascade parameters, access the Cascade Menu found in the Setup Menu by pressing the following buttons:



**Note:** The CASCADE button on the Main Menu will only display the current status of the cascade.

1. Once in the Cascade Setup Menu select the appropriate parameter by pressing the SELECT button.
2. The first time the cascade setup parameters are accessed, you will be required to enter the service password. Enter the service password as described in the SYNC Service Manual.
3. Once the password has been entered correctly, the Parameter Change Screen will appear. The Parameter Change Screen will display the parameter being changed, the previous setting of the parameter, and adjustment buttons.
4. To adjust the parameter, press the + or - buttons to change the value being displayed.
5. Make the correct adjustments and then press the APPLY button.
6. Once all the parameters have been adjusted press the BACK button. This will return you to the Setup Menu.
7. Press the SAVE button to program all controls.

**Note:** The SAVE button must be pressed to ensure proper programming of the controls. Failure to press the SAVE button will require all changes to be reprogrammed.

# 10 Operating information

## General

### How the boiler operates

The SYNC uses advanced stainless steel heat exchangers and electronic control modules that allow fully condensing operation. The blowers pull in air and push flue products out of the boiler through the heat exchangers and flue piping. The control modules regulate blower speed to control the boiler firing rate. The gas valve senses the amount of air flowing into the boiler and allows only the right amount of gas to flow.

### How the control modules operate

The SYNC boiler is equipped with two (2) SMART TOUCH control modules. The control modules work in synchronization to meet the heat demand of the system.

The SMART TOUCH control modules receive input from boiler sensors and external inputs. The control modules activate and control the blowers and gas valves to regulate heat input and switches the boiler, Hot Water Generator (HW), and system pumps on and off as needed. The user programs the control modules to meet system needs by adjusting control parameters. These parameters set operating temperatures and boiler operating modes. Boiler operation is based on system temperature.

### Control inputs and outputs

#### Room thermostat / zone control

This input tells the boiler to provide water for space heating.

#### Hot Water Generator (HW) tank thermostat

This input tells the boiler to provide water for heating an indirect HW tank.

#### 0 - 10V input (set point or power)

The SYNC can be controlled by a Building Management System (BMS) using a 0 - 10 VDC signal. The control can be configured by the installer to use this signal to either control set point or firing rate.

### HW priority

The SMART TOUCH control module allows connection of a HW thermostat to the low voltage connection board. When the HW thermostat calls for heat, the control modules activate the HW pumps, shuts down the boiler pumps, and immediately sets the target outlet water temperature to 180°F (82.2°C). This provides automatic priority heat allocation to the HW Generator for maximum response and recovery. The HW pumps continue for 30 seconds after the heating cycle to deliver the most possible heat.

### Controlling sensor

The control module is programmed to use the outlet sensor as the control sensor by default. If a system supply sensor is connected, the control automatically uses it as the control sensor.

### Anti-cycling

After a space heating demand has been satisfied, the control will delay the next space heating call for a set time period (time is adjustable by the installer). The time delay will be bypassed if the inlet water temperature drops too far during the delay.

### Boiler, system, and HW pump control

When a space heating call for heat starts and no HW call is on, the system and boiler pumps are turned on. As long as the space heating call for heat is on, the system pump will remain on. If a HW call for heat is on, the boiler pumps will wait to turn on until just before the HW pumps turn off. After the space heating call for heat ends, both pumps will run for an additional period of time.

When a HW call for heat starts, the HW pumps are turned on. If a space heating call for heat was on, the boiler pumps will turn off a few seconds after the HW pumps turn on.

### Louver

A dry contact is provided to open and close louvers whenever the SYNC boiler requires combustion air from inside the room. Connect the Louver End Switch to the Louver Proving Switch input on the Low Voltage Connection Board.

### Temperature control

#### Modulation

The SYNC is capable of modulating its firing rate from a minimum of 10% to a maximum of 100%. The firing rate is dictated by the call for heat (i.e., space heating or hot water generation), the heating load, and various other temperature limitations.

# 10 Operating information *(continued)*

## Gradient limiting

If during operation of the boiler the outlet water temperature is rising too quickly, the control will reduce the firing rate to its lowest setting.

## Outdoor air reset

If an outdoor air sensor is connected, the control module will calculate the set point based on the programmed reset curve. The installer can change the slope of the reset curve by several adjustable parameters. The user can limit the maximum set point for the system using the space heating set point.

## Boost function

If outdoor air reset is active, and a space heating demand has been active continuously for a set period of time (time adjustable by installer) and there has been no HW demands, the control will increase the set point by a fixed number of degrees (adjustable by installer). This process will continue until the space heating demand ends, the set point reaches the programmed set point or a maximum of 20 increases has occurred. Once the system heat demand is satisfied, the set point will revert to the value determined by the reset curve.

## Night setback

The controller may be programmed to reduce the space heating set point during a certain time each day. A start and stop time can be programmed for each day of the week.

## Flame current support

To prevent nuisance shutdowns when the boiler is firing at minimum rates, the control will increase the firing rate when the flame signal drops too low.

## Protection features

### Outlet temperature, flue temperature, and temperature rise limiting

The outlet temperature is monitored by the boiler outlet temperature sensor. When the outlet temperature exceeds 185°F (85°C), the unit will reduce the fan speed. If the outlet water temperature exceeds 195°F (90°C) the control will shut the unit down until it cools off.

The control module monitors the flue temperature by a sensor located in the flue exhaust. If the flue temperature exceeds 215°F (102°C) the control will reduce the maximum fan speed. If the flue temperature exceeds 225°F (107°C) the control will shut the unit down. The unit will restart automatically once the flue temperature drops 10°F (6°C) and the minimum off time has expired.

The control monitors the temperature difference between the inlet and the outlet sensor. If this difference exceeds 55°F (31°C) the control will reduce the fan speed. If the temperature difference exceeds 60°F (33°C) the control will shut the unit down. The unit will restart automatically once the temperature difference has dropped below 55°F (31°C) and the minimum off time has expired.

### Freeze protection

DO NOT install the boiler in a room likely to freeze.

The following integral feature of the SMART TOUCH control module provides some protection for the boiler only -- not for the system.

- The SMART TOUCH control module provides freeze-up protection as follows when the boiler water temperature drops below 45°F (7°C):
- Below 45°F (7°C), the boiler and system pumps operate constantly.
- Below 37°F (3°C), the boiler turns on.
- Boiler and pumps turn off if boiler water temperature rises above 45°F (7°C).

### **⚠ CAUTION**

This feature of the SMART TOUCH control module does not eliminate the possibility of freezing. The installation must still use recognized design, installation and maintenance practice to prevent freeze potential for the boiler and system.

# 10 Operating information

## Monitor external limits

Connections are provided on the connection board for external limits such as flow switch and a louver proving switch. The SMART TOUCH control will shut off the burner and inhibit relighting whenever any of these external limits open.

## Run-time and alarm outputs

The boiler provides dry contacts for indicating when the boiler is running, and when it is unable to operate.

## Run-time and cycle counting

The control uses two timers to monitor the total hours of burner operation. One timer monitors the time the boiler is firing under 50% of rate. The other timer monitors the time the boiler is firing over 50% rate.

The control uses four (4) ignition counters to monitor the amount of boiler cycles. The first counter counts all ignitions of the control. The second counter counts only ignition attempts that have failed. The third and fourth counters are the same as the first and second respectively, but can be reset by the installer.

## Service reminder

The control can be programmed for service reminder notification. This notification will become active when either a set time frame has expired, or a set amount of running hours or cycles has expired (all adjustable by the installer). The display will alternate the standard text on the display screen with Service Due every 5 seconds. The service reminder notification can be reset by the installer.

## Error logging

The control will hold in memory the last 10 error codes as well as the last 10 turn-off functions. The date and time of the occurrence will be recorded as well. Only the 10 most current occurrences will be held in memory.

## Boiler temperature regulation

### Operating temperature (target)

The SMART TOUCH control module senses water temperature and regulates boiler firing and firing rate to achieve a target temperature. The target temperature can be set between 70°F (21°C) and 190°F (88°C).

- Target temperature is fixed when the outdoor sensor is not installed.
- Target temperature is calculated as described below under “Outdoor Reset Operation” and “Target Temperature Boost” when the outdoor sensor is connected.

## High limit operations

When outlet temperature exceeds 200°F (93.3°C), high limit action occurs. The boiler shuts down until the outlet water cools down.

## Low water cutoff protection

1. A low water cutoff device with test and reset functionality is provided in the boiler as standard equipment.

## Flow sensing device

1. The SMART TOUCH control module uses temperature sensing of both supply and return temperatures of the heat exchanger. If the flow rate is too low or the outlet temperatures too high, the control module modulates down and will shut the boiler off. This ensures boiler shutdown in the event of low flow conditions.

### NOTICE

If a mechanical flow switch is required to meet local code requirements the SYNC boiler can be equipped with field supplied switches on each inlet. Please reference page 39 of this manual for more information.

## Outdoor reset operation, if used

### Target temperature with outdoor reset

This feature improves the system’s efficiency as the outdoor temperature warms up.

See the SYNC Service Manual to change the settings.

### Reset curve

The reset curve looks at outdoor air temperature and adjusts the set point.

## Cascade

When multiple boilers are installed, they can be wired together in a cascade sequence. A maximum of eight boilers can be controlled from a single control. In this application one boiler would be designated as the Leader control and all others would be designated as Member controls.

Once the Leader boiler receives a call for heat from the Enable input or 0 - 10 VDC input, the control will determine what the set point will be. If outdoor air reset is desired, connect the outdoor air sensor to the terminals on the Low Voltage Connection Board on the Leader boiler. The set point will be calculated based on the programmed reset curve parameters. See the SYNC Service Manual to program the reset curve. If outdoor air reset is not desired, do not connect the outdoor air sensor. A fixed temperature set point can be programmed into the control.

# 10 Operating information *(continued)*

If the water temperature at the system supply sensor is less than the set point + the turn-off offset - the off-on differential, then the control will initiate a call for heat on the Cascade (see the SYNC Service Manual for an explanation of the offset and differential). The Leader will energize the lead boiler on the Cascade. For a new startup this will be the Leader boiler.

The boiler will fire at its ignition speed and will then modulate its firing rate to maintain the set point. If the first boiler reaches 100% of its firing rate, the Leader will calculate at what point the second boiler could fire at 10% of its firing rate. At this point, the Leader will fire the second boiler on the Cascade. For a new startup, this would be the first Member boiler. The boiler will fire at its ignition speed and will then modulate its firing rate to maintain the set point.

If the set point still cannot be met, the Leader will continue firing more Members until either the heat demand is met or all boilers on the Cascade are firing. As the heat demand decreases, the last boiler on will modulate down to 10% of its firing rate. Once the demand for that boiler is zero, it will shut down. As the heat demand decreases further, the second to last boiler will modulate down and shut off. This will continue until the demand is satisfied and all boilers are shut off.

## Sequence of the cascade

To equalize the run time of all boilers on the Cascade, the firing sequence will automatically be changed at set intervals.

For the first 24 hours after initializing the Cascade, the sequence will be changed every hour. After that the sequence will be changed once every 24 hours. The switching on/off sequence will be as follows:

DAY	SWITCHING ON SEQUENCE
Day 1	L-M1-M2-M3-M4-M5-M6-M7
Day 1 + 1 hour	M2-M3-M4-M5-M6-M7-L-M1
Day 1 + 2 hours	M4-M5-M6-M7-L-M1-M2-M3

## HW operation with cascade

For HW operation any boiler(s) in the Cascade can be selected to provide heat for a HW call. Select a boiler to be designated as the HW boiler. Connect the HW thermostat or sensor to the terminals on the Low Voltage Connection Board marked for the HW Thermostat or sensor. When the boiler receives a HW call, the Leader control will take that boiler out of the Cascade sequence. If another boiler is available, the Leader will start it up to take its place.

The HW boiler will adjust its set point to the programmed HW set point and will adjust its firing rate to maintain this. Once the HW call has been satisfied, the Leader control will place that boiler back into the Cascade sequence.

## Night Setback operation with cascade

Night Setback operation of the boilers within the Cascade is available. Programming of the Night Setback will be done through the Leader boiler. Refer to the SYNC Service Manual for information regarding Night Setback.

# 10 Operating information

## Sequence of operation

**Note:** This unit is equipped with two (2) independent, but synchronized combustion systems. The Heat Exchanger 1 combustion system will fire first. If the demand cannot be met by one (1) combustion system the same sequence of operation will be followed to bring the Heat Exchanger 2 combustion system online.

1.	Upon a call for heat, the control turns on the appropriate pumps (system and boiler pumps for a space heating call, HW pump relay output for a HW call).
2.	The control confirms that the low water cutoff and flow switch (optional) contacts are closed.
3.	The control starts the blower and closes the louver contacts to begin the Pre-Purge cycle.
4.	The control confirms that the blower comes up to the desired speed, the flap valve opens, and the air pressure switch, gas pressure switch (optional), louver proving switch (optional), and blocked drain switch contacts close.
5.	Once the Pre-Purge cycle is complete, the control lowers the blower speed, initiates sparking of the ignition electrode, and opens the gas valve.
6.	After a short wait, the control stops sparking and checks for the presence of flame current through the spark and flame sense electrodes.
7.	If the control does not detect flame current, the control will lockout indefinitely, until the RESET button on the touch screen LCD is pressed.
8.	If the control detects flame current, the control will hold the blower speed constant for a few seconds to allow the flame to stabilize, then begin modulating the firing rate in order to maintain the controlling sensor to the desired set point temperature.
9.	If the current call for heat is for space heating and a HW call for heat becomes active, the control will turn on the HW pump relay output, then turn off the boiler pumps. It will then modulate the blower speed in order to maintain the outlet temperature to the desired HW outlet set point temperature.
10.	If the first heat exchanger in the boiler is unable to maintain the desired set point temperature, the second heat exchanger in the boiler will be started, using much of the same sequences as described above. Once both heat exchangers are firing, the controls will work in synchronization to maintain the desired set point temperature. If the heat load should decrease sufficiently, the second heat exchanger will be shut down, much like the sequences described below.
11.	Once both the space heating and HW calls for heat are satisfied, the control will turn off the gas valve and begin the Post-Purge cycle. Any pumps that are running will begin their respective Pump Delay cycles.
12.	At the end of the Post-Purge cycle, the louver contacts will open.
13.	The control verifies that the blower stops running and the flap valve closes.
14.	At the end of the Pump Delay cycle(s), the pump(s) will be turned off.

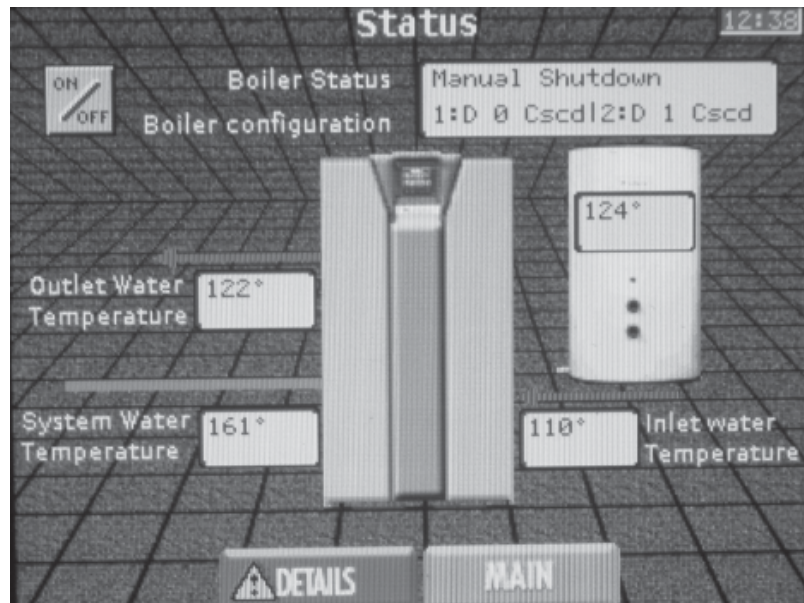
# 10 Operating information *(continued)*

## **SMART TOUCH**™ SYNC control module

The Status Screen displays boiler status, Cascade addresses, outlet water temperature, inlet water temperature, system temperature, and tank temperature.

The boiler can be changed by pressing the ON/OFF button. The Details Screen and Main Menu Screen can be accessed by pressing the appropriate button.

**Figure 10-1** Status Screen



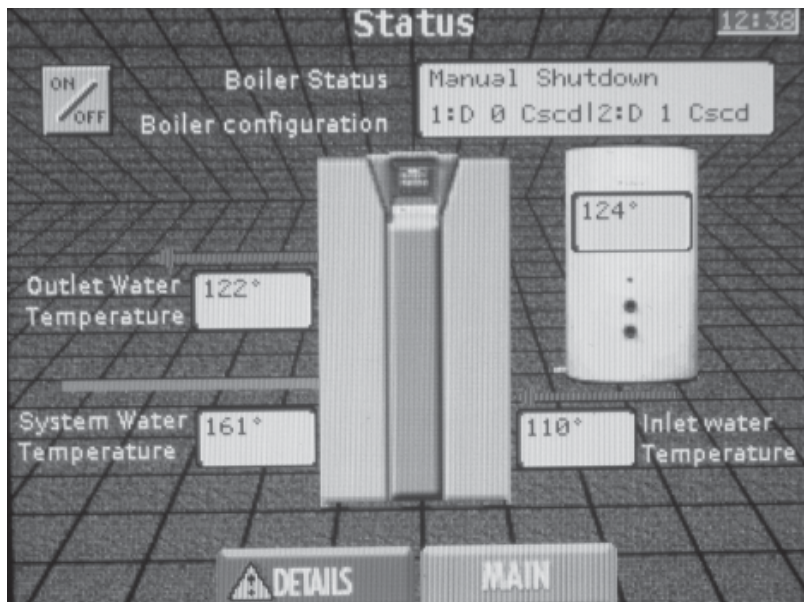
When the ON/OFF switch is turned to the ON position, the first screen visible on the LCD display will be the Status Screen. This screen displays the current status of the SYNC boiler. The following items can be viewed or interacted with on the Status Screen:

**On/Off** button - Pressing this button allows the boiler to be placed in either Manual Shutdown Mode or Standby Mode.

**Boiler Status** - This line shows the current operating status of the SYNC boiler. Displayed items are as follows:

- Manual Shutdown - The boiler will not respond to either a system call or a hot water generation call.
- Standby - The boiler has not received a system call or hot water generation call.
- SH Call for Heat - The boiler has received a system heat call.
- SH Pump Delay - The boiler has satisfied a system heat call and the boiler pumps are running for a fixed time to remove any residual heat.
- HW Storage - The boiler has received a hot water generation call.
- HW Pump Delay - The boiler has satisfied a hot water generation call and the hot water generator pumps are running for a fixed time to remove any residual heat.
- SH BMS - The boiler has received a call for heat from a 0-10 VDC BMS control.
- Service Set Point Met - While in Service Mode, the water temperature at either the outlet sensor or the system sensor has exceeded 185°F.
- HW Outlet Set Point Met - The outlet water temperature has exceeded the HW Generator Set Point parameter.
- OA Shutdown - The outside air temperature has exceeded the Outdoor Shutdown Set Point parameter.
- SH Set Point Met - The water temperature as measured by the system supply sensor has exceeded the User Set Point parameter or if the optional Outdoor Air Sensor was used, the calculated set point based on the Outdoor Reset parameters.
- Anti-Cycle Delay - The boiler has satisfied a system heat call, but has received another system heat call before the anti-cycling time parameter has elapsed.
- Cascade ComError - A communication error has occurred between the Control Module 1 and Control Module 2 or between the Leader and Member boilers.

# 10 Operating information



**Boiler Configuration** - This line shows the current configuration of the two control modules inside the unit.

**Outlet Water Temperature** - This is a calculated temperature based on the readings of the outlet temperatures of the two (2) heat exchangers.

**System Water Temperature** - This is the water temperature as measured by the system supply sensor located in the downstream piping.

**Inlet Water Temperature** - This is a calculated temperature based on the inlet temperature readings from the two (2) heat exchangers.

**Hot Water Tank Temperature** - This is the temperature as measured by the tank sensor in the hot water storage tank.

**Time** - The time is displayed in the upper right-hand corner of the display. It is displayed in 24 hour format. Reference the SYNC Service Manual for Night Setback parameters and more information regarding adjusting the date and time.

**Details** button - Pressing this button brings up the Details Screen. This screen shows the status of the various safeties, inputs, and outputs to each control module. Reference the Details Screen section in the SYNC Service Manual for more information regarding this screen.

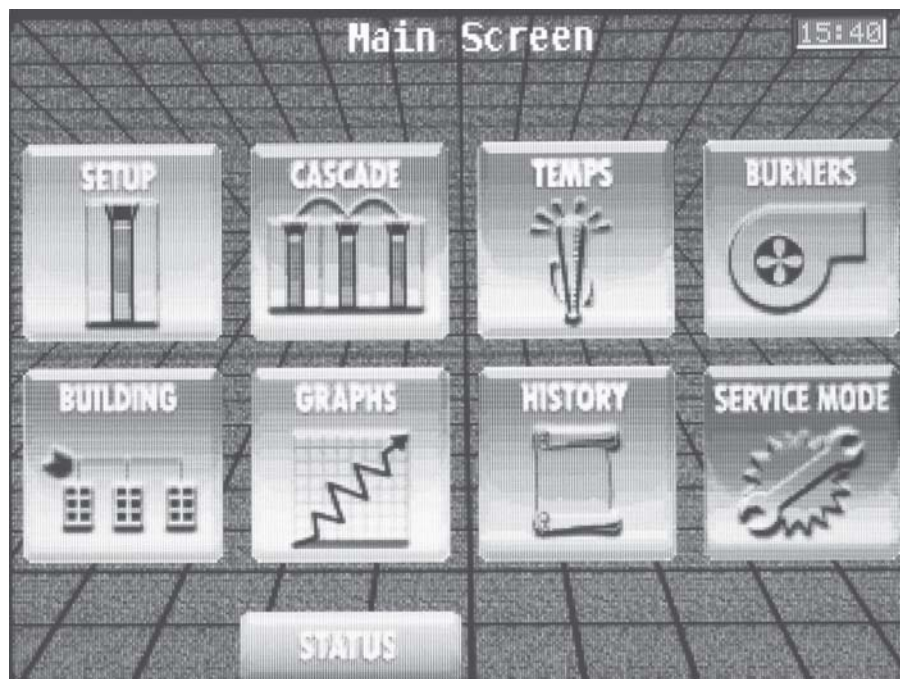
**Main** button - Pressing this button brings up the Main Screen. From this screen navigation to eight (8) other screens is possible. Reference the Main Screen section on page 57 of this manual for more information regarding this screen.

# 10 Operating information *(continued)*

Use the Main Menu Screen (FIG. 10-2) to access the screens necessary to set temperatures, operating conditions, and monitor boiler operation.

The SYNC is equipped with a SMART TOUCH control system. All menu options are accessed by touching the screen with your finger or a stylus from a PDA.

**Figure 10-2** Main Menu Screen



The Main Screen allows navigation to eight (8) additional screens which are used to set temperatures, operating conditions, and monitor boiler operation. These screens are as follows:

- Setup - Allows access to seven (7) other screens for the adjustment of the control parameters.
- Cascade - Shows the status of multiple boilers connected together in a cascade arrangement.
- Temps - Shows the temperatures measured by the individual sensors connected to the boiler.
- Burners - Shows the status of the two (2) independent burner systems used in the boiler.
- Building - Shows the information from a Building Integration System using Modbus Protocols.
- Graphs - Allows the selection of items to be graphed on a chart.
- History - Shows the operating and fault history of the two (2) control modules.
- Service Mode - Allows the installer to control the fan speed of the individual control modules for the purposes of combustion analysis. Service Mode will override all other heat demands, however, all safeties will remain intact.

Navigation to the Main Screen can be accomplished by pressing the MAIN button at the bottom of the page.

Reference the SYNC Service Manual for more information regarding the eight (8) accessible screens.

**Time** - The time is displayed in the upper right-hand corner of the display. It is displayed in 24 hour format. Reference the night setback parameters in the SYNC Service Manual for information regarding adjusting the date and time.

**Status** button - Pressing this button displays the Status Screen. This screen shows the current status of the SYNC boiler. Reference pages 55 - 56 for more information regarding this screen.

# 11 Maintenance

## Maintenance and annual startup

**Table 11A** Service and Maintenance Schedules

Service technician (see the following pages for instructions)		Owner maintenance (see the SYNC User's Information Manual for instructions)	
<b>ANNUAL START-UP</b>	<b>General:</b>	<b>Daily</b>	<ul style="list-style-type: none"> <li>• Check boiler area</li> <li>• Check pressure/temperature gauge</li> </ul>
	<ul style="list-style-type: none"> <li>• Address reported problems, if any</li> <li>• Inspect interior; clean and vacuum if necessary;</li> <li>• Clean condensate trap and fill with fresh water</li> <li>• Check for leaks (water, gas, flue, condensate)</li> <li>• Verify flue and air lines in good condition and sealed tight</li> <li>• Check system water pressure/system piping/expansion tank</li> <li>• Check fill water meter</li> <li>• Test boiler water. When test indicates, clean system water with approved system restorer following manufacturer's information.</li> <li>• Check control settings</li> <li>• Check ignition and flame sense electrodes (sand off any deposits; clean and reposition)</li> <li>• Check wiring and connections</li> <li>• Perform start-up checkout and performance verification per Section 9.</li> <li>• Flame inspection (stable, uniform)</li> <li>• Flame signal (at least 10 microamps at high fire)</li> <li>• Clean the heat exchanger if flue temperature is more than 54°F (30°C) above return water temperature.</li> <li>• Test low water flow conditions (reference the SYNC Service Manual).</li> </ul>	<b>Monthly</b>	<ul style="list-style-type: none"> <li>• Check vent piping</li> <li>• Check air piping</li> <li>• Check air and vent termination screens</li> <li>• Check relief valve</li> <li>• Check condensate drain system</li> <li>• Check automatic air vents</li> </ul>
	<p><b>If combustion or performance indicate need:</b></p> <ul style="list-style-type: none"> <li>• Clean heat exchanger</li> <li>• Remove and clean burner using compressed air only</li> <li>• Clean the blower wheel</li> </ul>	<b>Every 6 months</b>	<ul style="list-style-type: none"> <li>• Test low water cutoff</li> <li>• Reset button (low water cutoff)</li> <li>• Check boiler piping (gas and water) for leaks</li> <li>• Operate relief valve</li> </ul>
		<b>End of season months</b>	<ul style="list-style-type: none"> <li>• Shut boiler down (unless boiler used for domestic hot water)</li> </ul>

# 11 Maintenance *(continued)*

**⚠ WARNING** Follow the service and maintenance procedures given throughout this manual and in component literature shipped with the boiler. Failure to perform the service and maintenance could result in damage to the boiler or system. Failure to follow the directions in this manual and component literature could result in severe personal injury, death, or substantial property damage.

**⚠ WARNING** The boiler should be inspected annually only by a qualified service technician. In addition, the maintenance and care of the boiler designated in Table 11A and explained on the following pages must be performed to assure maximum boiler efficiency and reliability. Failure to service and maintain the boiler and system could result in equipment failure.

**⚠ WARNING** Electrical shock hazard – Turn off power to the boiler before any service operation on the boiler except as noted otherwise in this instruction manual. Failure to turn off electrical power could result in electrical shock, causing severe personal injury or death.

## Address reported problems

1. Inspect any problems reported by the owner and correct before proceeding.

## Inspect boiler area

1. Verify that boiler area is free of any combustible materials, gasoline and other flammable vapors and liquids.
2. Verify that air intake area is free of any of the contaminants listed in Section 1 of this manual. If any of these are present in the boiler intake air vicinity, they must be removed. If they cannot be removed, reinstall the air and vent lines per this manual.

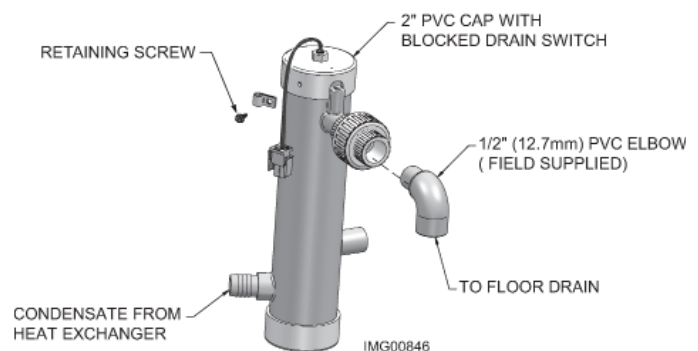
## Inspect boiler interior

1. Remove the front access cover and inspect the interior of the boiler.
2. Vacuum any sediment from inside the boiler and components. Remove any obstructions.

## Clean condensate trap

1. Inspect the condensate drain line, condensate PVC fittings, and condensate trap.
2. Remove the PVC cap retaining screw from the PVC cap (FIG. 11-1).
3. Remove the 2 inch PVC cap with the switch located at the top of the trap (FIG. 11-1).
4. Remove any sediment in the trap.
5. Fill with fresh water until the water begins to pour out of the drain.
6. Replace the cap. Press the cap onto the trap until the cap makes contact with the drain.
7. Replace the retaining screw.

**Figure 11-1** Condensate Trap



**⚠ WARNING** The condensate trap must be filled with water during all times of boiler operation to avoid flue gas emission from the condensate drain line. Failure to fill the trap could result in severe personal injury or death.

## Check all piping for leaks

**⚠ WARNING** Eliminate all system or boiler leaks. Continual fresh makeup water will reduce boiler life. Minerals can build up in sections, reducing heat transfer, overheating heat exchanger, and causing heat exchanger failure. Leaking water may also cause severe property damage.

1. Inspect all water and gas piping and verify to be leak free.
2. Look for signs of leaking lines and correct any problems found.
3. Check gas line using the procedure found in Section 6 - *Gas Connections*.

# 11 Maintenance

## Flue vent system and air piping

1. Visually inspect the entire flue gas venting system and air piping for blockage, deterioration or leakage. Repair any joints that show signs of leakage. Verify that air inlet pipe is connected and properly sealed.
2. Verify that boiler vent discharge and air intake are clean and free of obstructions.

**⚠ WARNING** Failure to inspect for the above conditions and have them repaired can result in severe personal injury or death.

## Check water system

1. Verify all system components are correctly installed and operational.
2. Check the cold fill pressure for the system. Verify it is correct (must be a minimum of 12 psi (82.7 kPa)).
3. Watch the system pressure as the boiler heats up (during testing) to ensure pressure does not rise too high. Excessive pressure rise indicates expansion tank sizing or performance problem.
4. Inspect automatic air vents and air separators. Remove air vent caps and briefly press push valve to flush vent. Replace caps. Make sure vents do not leak. Replace any leaking vents.

## Check expansion tank

1. Expansion tanks provide space for water to move in and out as the heating system water expands due to temperature increase or contracts as the water cools. Tanks may be open, closed or diaphragm or bladder type. See Section 5 - *Hydronic Piping* for suggested best location of expansion tanks and air eliminators.

## Check fill water meter

1. Check fill water meter for water usage. If the amount exceeds 5% of your system volume, you could have a leak. Have the system checked for leaks and fixed by a qualified service technician.

## Test boiler water

1. Test boiler water. Reference the Crest Installation and Operation Manual for guidelines. When test indicates, clean system water with approved system restorer following the manufacturer's information.

## Check boiler relief valve

1. Inspect the relief valve and lift the lever to verify flow. Before operating any relief valve, ensure that it is piped with its discharge in a safe area to avoid severe scald potential. Read Section 5 - *Hydronic Piping* before proceeding further.

**⚠ WARNING** Safety relief valves should be re-inspected AT LEAST ONCE EVERY THREE YEARS, by a licensed plumbing contractor or authorized inspection agency, to ensure that the product has not been affected by corrosive water conditions and to ensure that the valve and discharge line have not been altered or tampered with illegally. Certain naturally occurring conditions may corrode the valve or its components over time, rendering the valve inoperative. Such conditions are not detectable unless the valve and its components are physically removed and inspected. This inspection must only be conducted by a plumbing contractor or authorized inspection agency – not by the owner. Failure to re-inspect the boiler relief valve as directed could result in unsafe pressure buildup, which can result in severe personal injury, death, or substantial property damage.

**⚠ WARNING** Following installation, the valve lever must be operated AT LEAST ONCE A YEAR to ensure that waterways are clear. Certain naturally occurring mineral deposits may adhere to the valve, rendering it inoperative. When manually operating the lever, water will discharge and precautions must be taken to avoid contact with hot water and to avoid water damage. Before operating lever, check to see that a discharge line is connected to this valve directing the flow of hot water from the valve to a proper place of disposal. Otherwise severe personal injury may result. If no water flows, valve is inoperative. Shut down the boiler until a new relief valve has been installed.

2. After following the above warning directions, if the relief valve weeps or will not seat properly, replace the relief valve. Ensure that the reason for relief valve weeping is the valve and not over-pressurization of the system due to expansion tank waterlogging or undersizing.

# 11 Maintenance *(continued)*

## Inspect ignition and flame sense electrodes

1. Remove the ignition and flame sense electrodes from the boiler heat exchanger access covers.
2. Remove any deposits accumulated on the ignition/flame sense electrode using sandpaper. If the electrodes cannot be cleaned satisfactorily, replace with new ones.
3. Replace ignition/flame sense electrodes, making sure the gaskets are in good condition and correctly positioned.

## Check ignition ground wiring

1. Inspect boiler ground wire from the heat exchanger access cover to ground terminal strip.
2. Verify all wiring is in good condition and securely attached.
3. Check ground continuity of wiring using continuity meter.
4. Replace ground wires if ground continuity is not satisfactory.

## Check all boiler wiring

1. Inspect all boiler wiring, making sure wires are in good condition and securely attached.

## Check control settings

1. Set the control module display to Parameter Mode and check all settings. See Section 1 of the SYNC Service Manual. Adjust settings if necessary. See Section 1 of the SYNC Service Manual for adjustment procedures.
2. Check settings of external limit controls (if any) and adjust if necessary.

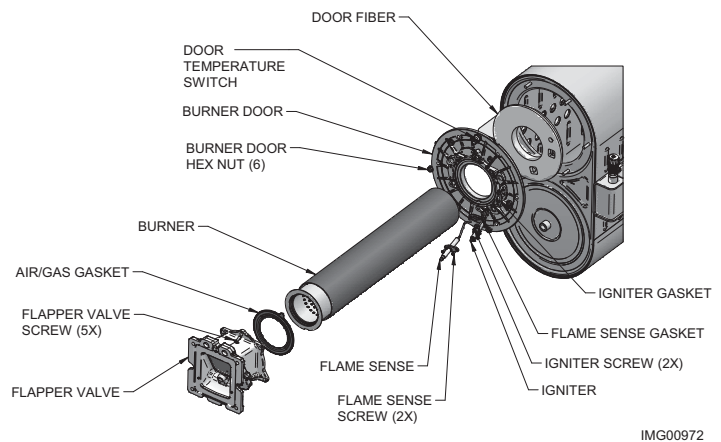
## Perform start-up and checks

1. Start boiler and perform checks and tests specified in Section 9 - *Start-up*.
2. Verify cold fill pressure is correct and that operating pressure does not go too high.

## Check burner flame

1. Inspect flame through observation window.
2. If the flame is unsatisfactory at either high fire or low fire, turn off boiler and allow boiler to cool down. Remove the burners and clean them thoroughly using a vacuum cleaner or compressed air. Do not use compressed air to clean burners if performed inside a building.
3. Remove the burners, reference FIG. 11-2.
4. When replacing the burners, ensure gaskets are in good condition and positioned correctly (FIG. 11-2).

**Figure 11-2 Burner Assembly**



IMG00972

## Check flame signal

1. At high fire the flame signal shown on the display should be at least 10 microamps.
2. A lower flame signal may indicate a fouled or damaged flame sense electrode. If cleaning the flame sense electrode does not improve, ground wiring is in good condition, and ground continuity is satisfactory, replace the flame sense electrode.
3. See Section 3 - *Troubleshooting* in the SYNC Service Manual for other procedures to deal with low flame signal.

## Review with owner

1. Review the SYNC User's Information Manual with the owner.
2. Emphasize the need to perform the maintenance schedule specified in the SYNC User's Information Manual (and in this manual as well).
3. Remind the owner of the need to call a licensed contractor should the boiler or system exhibit any unusual behavior.
4. Remind the owner to follow the proper shutdown procedure and to schedule an annual start-up at the beginning of the next heating season.

# 11 Maintenance

## Cleaning boiler heat exchanger

For recommended materials; including brush, appropriate extension(s), refractory cover, and detailed instructions see Table 11B - Heat Exchanger Cleaning Kits.

- Shut down boiler:
  - Follow the "To Turn Off Gas to Appliance" instructions for the boiler in Section 9 - Startup.
  - Do not drain the boiler unless it will be exposed to freezing temperatures. If using freeze prevention fluid in system, do not drain.
- Allow time for the boiler to cool to room temperature if it has been firing.
- Remove the nuts securing the heat exchanger access cover to the heat exchanger and set aside.
- Remove the heat exchanger access cover, burner, and gas/air arm assembly.

**WARNING** The boiler contains ceramic fiber materials. Use care when handling these materials per instructions on page 63 of this manual. Failure to comply could result in severe personal injury.

- Remove the condensate hose from the heat exchanger end. Connect a field supplied 3/4" diameter hose to a drain pan. Using field supplied means, cover the refractory in the back of the combustion chamber of the heat exchanger.
- Use a vacuum cleaner to remove any accumulation on the boiler heating surfaces. Do not use any solvent.
- Brush the heat exchanger while dry using a nylon bristle brush. **Caution:** DO NOT use a metal brush. Re-vacuum the heat exchanger.
- Finish cleaning using a clean cloth dampened with warm water. Rinse out debris with a low pressure water supply.
- Allow the heat exchanger to thoroughly dry.
- Remove the field supplied rear refractory cover from the back of the combustion chamber of the heat exchanger and reassemble.
- Close isolation valves on piping to isolate boiler from system. Attach a hose to the boiler drain and flush boiler thoroughly with clean water by using purging valves to allow water to flow through the water make-up line to the boiler.
- Perform start-up and check-out procedures in the Check Flame and Combustion - Section 9 - Startup on pages 46 and 48 of this manual.
- Replace the access cover and restore boiler to operation.

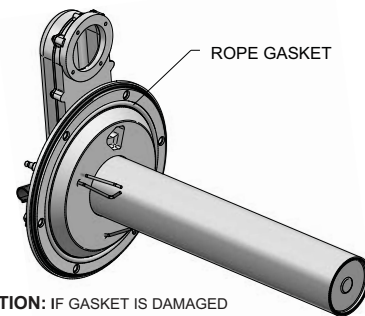
**Table 11B** Heat Exchanger Cleaning Kits

Model Number	Kit Number	Part Number	Component Description
SB 1.0 - 1.5	100157628	100162565*	Nylon 4" Wheel Brush*
		100162567	1/4" x 12" Drill Extension
		100162568	1/4" x 24" Drill Extension

**CAUTION**

\* Do NOT use a metal brush. Only use the kit provided brush or an equivalent replacement nylon brush.

**Figure 11-3** Rope Gasket - Heat Exchanger Door



**CAUTION:** IF GASKET IS DAMAGED DO NOT REUSE, THE HEAT EXCHANGER DOOR MUST BE REPLACED.

**NOTICE**

Rope gasket is intended for sealing combustion (FIG. 11-3). If damaged DO NOT reuse, the heat exchanger door must be replaced. Consult factory for replacement heat exchanger door (kit 100173799).

# 11 Maintenance *(continued)*

## Handling ceramic fiber materials

### REMOVAL OF COMBUSTION CHAMBER LINING

**⚠ WARNING**

The combustion chamber insulation in this appliance contains ceramic fiber material. Ceramic fibers can be converted to cristobalite in very high temperature applications. The International Agency for Research on Cancer (IARC) has concluded, "Crystalline silica in the form of quartz or cristobalite from occupational sources is carcinogenic to humans (Group 1)." Normal operating temperatures in this appliance are below the level to convert ceramic fibers to cristobalite. Abnormal operating conditions would have to be created to convert the ceramic fibers in this appliance to cristobalite.

The ceramic fiber material used in this appliance is an irritant; when handling or replacing the ceramic materials it is advisable that the installer follow these safety guidelines.

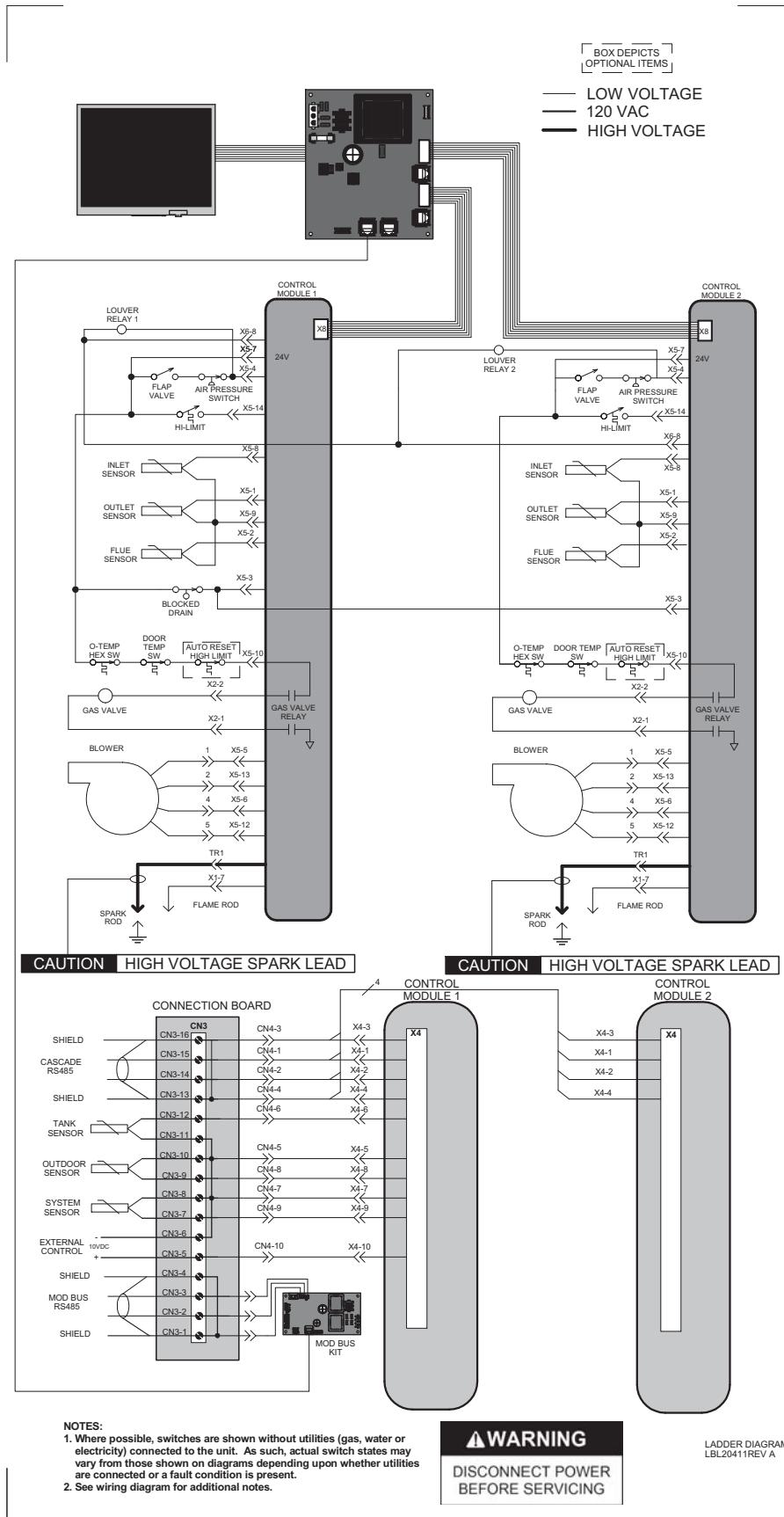
- Avoid breathing dust and contact with skin and eyes.
  - Use NIOSH certified dust respirator (N95). This type of respirator is based on the OSHA requirements for cristobalite at the time this document was written. Other types of respirators may be needed depending on the job site conditions. Current NIOSH recommendations can be found on the NIOSH website at <http://www.cdc.gov/niosh/homepage.html>. NIOSH approved respirators, manufacturers, and phone numbers are also listed on this website.
  - Wear long-sleeved, loose fitting clothing, gloves, and eye protection.
- Apply enough water to the combustion chamber lining to prevent airborne dust.
- Remove the combustion chamber lining from the boiler and place it in a plastic bag for disposal.
- Wash potentially contaminated clothes separately from other clothing. Rinse clothes washer thoroughly.

#### NIOSH stated First Aid.

- Eye: Irrigate immediately.
- Breathing: Fresh air.

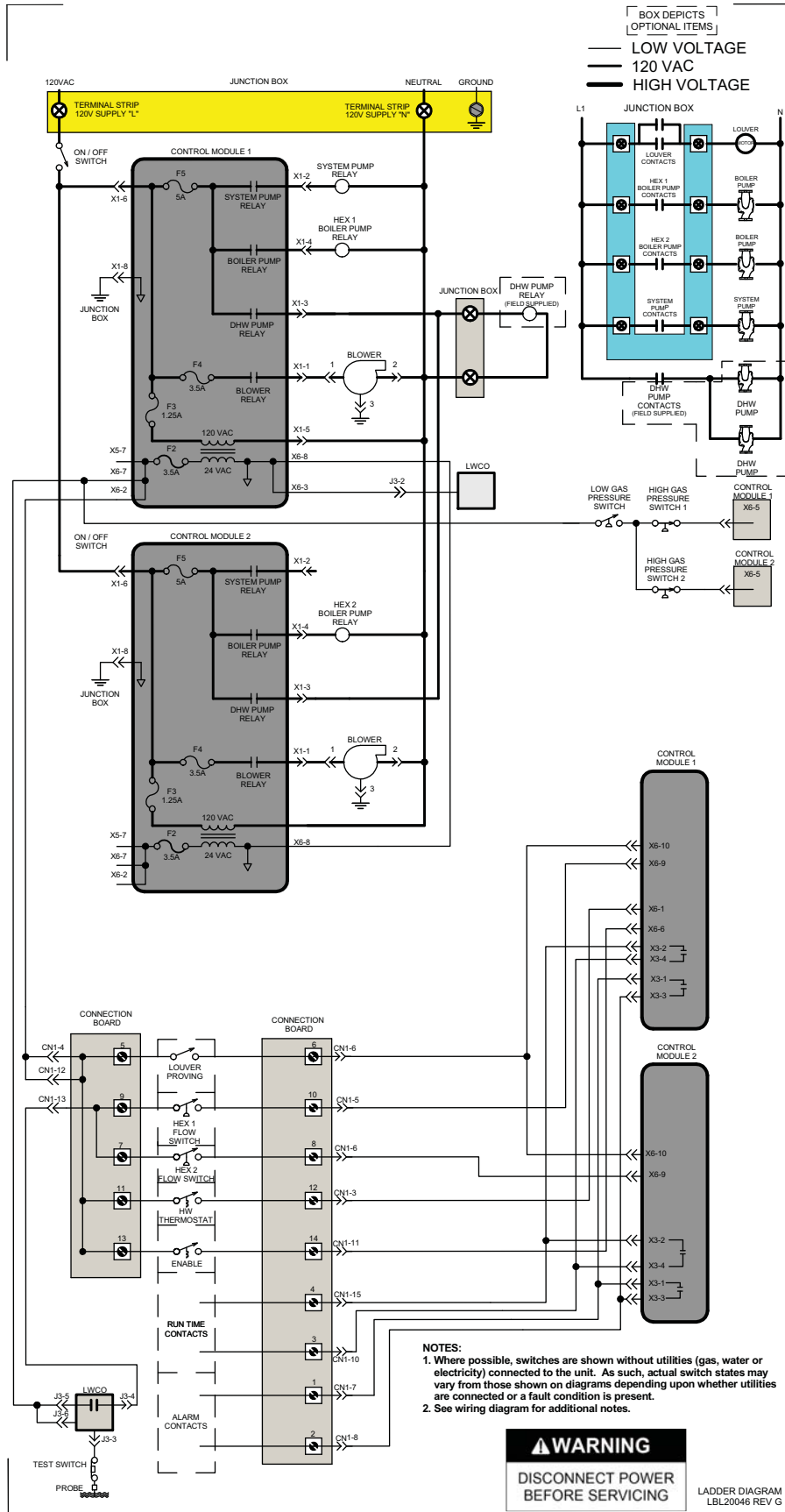
# 12 Diagrams

Figure 12-1 Ladder Diagram\_Part 1



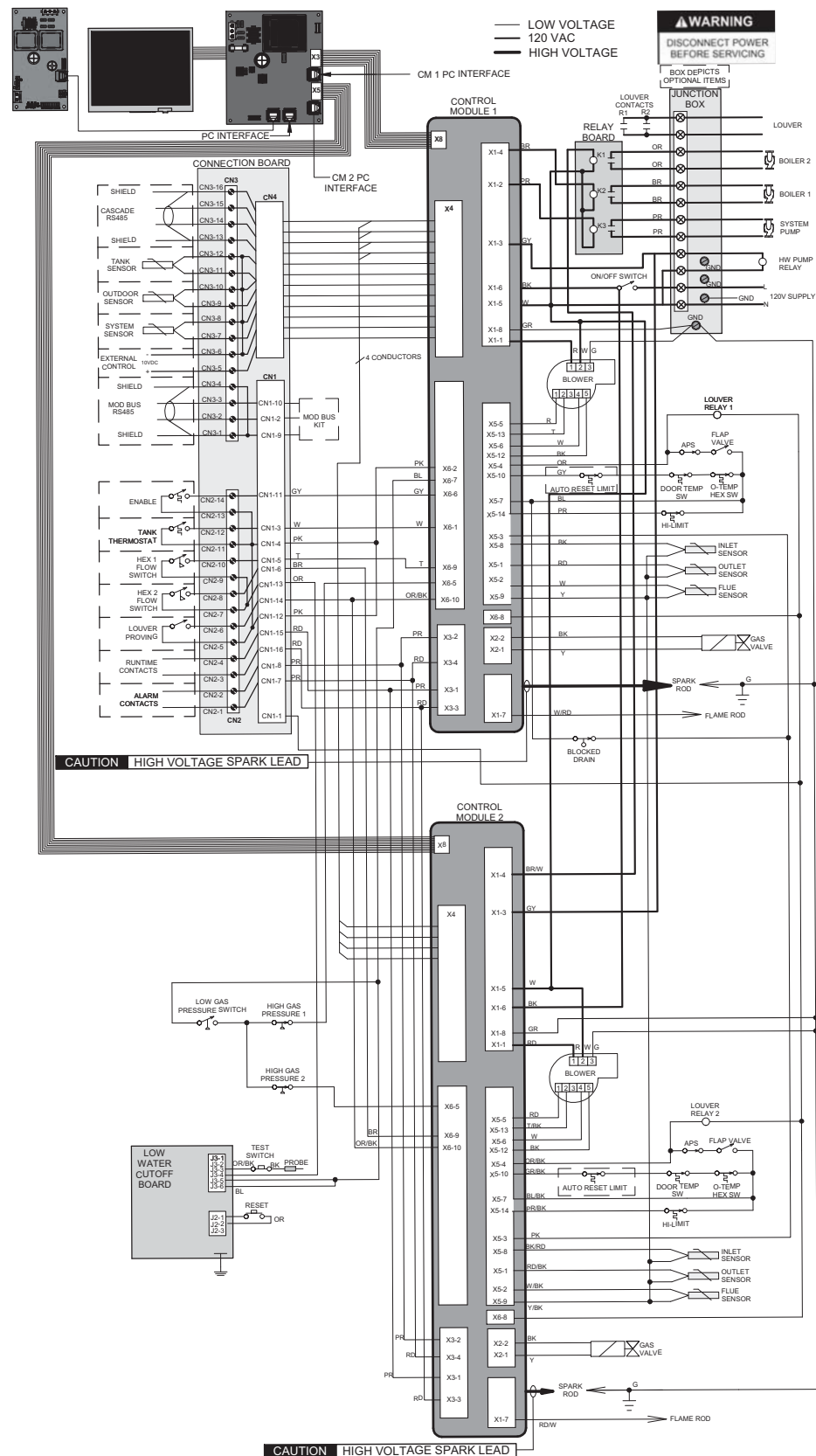
# 12 Diagrams (continued)

Figure 12-2 Ladder Diagram\_Part 2



# 12 Diagrams

Figure 12-3 Wiring Diagram



**CAUTION HIGH VOLTAGE SPARK LEAD**

Notes:  
 1. All wiring must be installed in accordance with local, state, provincial and national code requirements per either N.E.C. in USA or C.S.A. in Canada.  
 2. If any original equipment wire as supplied with the appliance must be replaced, it must be replaced with wire having same wire gauge (AWG) and rated for a minimum of 105°C. Exceptions: Replacement high voltage spark lead and ribbon cables must be purchased from the factory. Use of a non-approved spark lead or ribbon cables can lead to operational problems which could result in non-reparable damage to the integrated controller or other components.  
 3. Actual connector block locations may vary from those shown on diagrams. Refer to actual components for proper connector block locations when using diagrams to troubleshoot unit.

# Notes

---

**Revision Notes:** Revision A (ECO #C02428) initial release.

Revision B (ECO #C03046) reflects the addition of FIG. 5-3 on page 27, the addition of a pressure gauge to FIG. 5-6 on page 30, edits made to FIG. 7-1 on page 35, edits made to the Low Water Cutoff Protection section on page 48 along with the addition of the Flow Sensing Device section.

Revision C (ECO #C03223) reflects edits made to the high altitude section on page 6.

Revision D (ECO #C03735) reflects edits made to the venting section removal of B149.2, along with the addition of the hydro and dirt separator.

Revision E (ECO #C04062) reflects changes to the terminology in all SYNC manuals and labels from module to heat exchanger (exception: control module), along with changing out "dirt separator" for "Y-strainer (ECR #R02455), edits made to the ceramic fiber material warning, removal of the stabilitor from FIG. 11-2 (C04057), and placing the illustrations disclaimer on all the piping drawings (ECR #R02431).

Revision F (ECO #C04560) reflects the addition of Modbus to the manual, new heat exchanger cleaning procedure, schedule 80 as acceptable CPVC material (Table 2A) (R02799), and changes made to Table 5A.

Revision G (ECO C07283) reflects the update of FIG. 7-1 on page 38 to show current label and wiring connections along with an update to the Ladder and Wiring diagrams on pages 64 and 65.

Revision H (ECO C07679) reflects the update of FIG. 6-1 on page 34 to show the gas pressure regulator, ECR 04077 - combustible water pipes changed from 1" to a 1/4", addition of the rope gasket notice on page 61 (R03940) and changes made to Table 2A on page 19.

Revision I (ECO C07981) reflects the addition of the O-temp switch and edits made to LBL20045 (ECR R04243 and C07959 - add O-temp switch, changes made to Table 5A on page 31 (ECR R04335) and change Module 1 and 2 callouts to HEX 1 and 2 on the label).

Revision J (ECO C08327) reflects changes made to the temperature callouts under Protection Features on page 50 (ECR R04145).

Revision K (ECO C08407) reflects updates made to LBL20045 (ECR R04434) along with changing the water outlet from 2 1/2" NPT to 3" NPT (ECR R04003), pages 4, 6, and 31 and updating the O-temp switch description on page 4.

Revision L (ECO #C08689) reflects additional information added to the humidity warning on page 7, updates made to LBL20046 Rev F (ECO C08689), the addition of the new Polypropylene Vent material section and rearranging the venting section.

Revision M (ECO C09691) reflects the update of AHRI and ASME logos on page 6.

Revision N (ECO C10594) reflects the update of Wiring and Ladder diagrams on pages 64 and 65.

Revision O (ECO 11393) reflects edits made to Table 5A on page 31 along with changes made to the starter piece callout in the Warning on page 19.

Revision P (ECO #C11814) reflects the addition of Metal Fab as an approved supplier.

Revision Q (ECO #C14411) reflects the removal of the page number reference on page 14, changes made to Table 6A - Gas Piping Chart on page 36 (R6621), along with the condensate trap changes (R06594), and the addition of the corrosive contaminant warning on pages 3 and 7 (R06313).

Revision R (ECO #C14713) reflects high altitude updates.

Revision S (ECO #C15251) reflects the addition of the burner door temperature switch updates (R6322).

Revision T (ECO C17014) reflects the standardization of pressure drop information on pages 35 and 36.

Revision U (Change #500000695) reflects the addition of ICC venting options on page 21 (R06799) along with edits made to the notice on the piping diagrams on pages 32 and 33 (C16461), edits made to the outlet sensor callout on page 4 (R07074) and the addition of the California contaminant warning on page 3 (R07228).

Revision V (PCP # 3000001143 / Change #500002167) reflects the addition of edits made to Boiler Water on page 3, along with the addition of the Important and Notice items under General Piping Information on page 28, as well as edits to section 9 (Start-up) on pages 43 and 44. SAP part numbers have been updated.

Revision W (PCP# 3000003998 / CN# 500004062) reflects a change to the Duravent Polypro Adapter number in Table 2E on page 20.

Revision X (PCP# 3000004438 / CN# 500005574) reflects an update to the flue temperatures on page 51.

Revision Y (PCP# 3000006133 / CN# 500007549) reflects the addition of a PVC-DWV vent fitting in Table 2C on page 19.

Revision AA (PCP #3000009530 / CN #500009744) reflects changes made to water chemistry information on pages 3, 7, 28-29, 31-33, 43-44, 58, and 60.

SYNC-I-O\_MM #100161722\_DIR #2000017704\_Rev AA  
08/17