

CREST[®]

CONDENSING BOILER
w/RealTime O₂ Trim[™]

Service Manual

Models: 1000 - 6000

Series: 100

HELLCAT[™]
Combustion Technology



⚠ WARNING

This manual must only be used by a qualified heating installer / service technician. Read all instructions, including this manual and the Crest Installation and Operation Manual, before installing. Perform steps in the order given. Failure to comply could result in severe personal injury, death, or substantial property damage.

Save this manual for future reference.

Contents

CONTENTS	2	Night Setback Screen	25-26
Hazard Definitions.....	2	Pump Screen	27-28
PLEASE READ BEFORE PROCEEDING	3	Cascade Screens	29-31
Handling Ceramic Fiber Materials.....	3	Service Screen.....	32
When servicing boiler	4	Graph Screens.....	33
Boiler operation.....	4	History Screens.....	34
Boiler water.....	4	2. MAINTENANCE	
Freeze protection fluids	4	Maintenance and Annual Startup.....	35-40
WHAT IS IN THIS MANUAL	5	3. TROUBLESHOOTING	
1. SERVICE		Before Troubleshooting.....	41
Boiler Piping.....	6	Check Control Module Fuses	41
SMART TOUCH w/CON•X•US Interface	7	Table 3A - Troubleshooting Chart - No Display.....	42
General Operation	8	Table 3B - 3E Checking Temperature Sensors.....	43
Control Inputs	9	Table 3F - Troubleshooting Chart - Noisy System	44
Control Outputs.....	10	Table 3G - Troubleshooting Chart - Fault Messages .	45-54
Table 1A - Sequence of Operation	11	Combustion Analysis Procedure	55
Initial Setup Screen.....	12	Table 3H - Flue Products.....	55
Viewable and Changeable Control Parameters.....	13	Table 3I - Troubleshooting Chart - Combustion Levels .	56
Set Point Screen.....	13-15	Gas Valve Adjustment Procedure.....	57
Outdoor Reset Screen.....	16-17	Revision Notes	Back Cover
Ramp Delay Screen	18-19		
BMS Screen.....	20-22		
Advanced Setup Screen.....	23-24		

Hazard definitions

The following defined terms are used throughout this manual to bring attention to the presence of hazards of various risk levels or to important information concerning the life of the product.

 **DANGER** DANGER indicates an imminently hazardous situation which, if not avoided, will result in death or serious injury.

 **WARNING** WARNING indicates a potentially hazardous situation which, if not avoided, could result in death or serious injury.

 **CAUTION** CAUTION indicates a potentially hazardous situation which, if not avoided, may result in minor or moderate injury.

CAUTION CAUTION used without the safety alert symbol indicates a potentially hazardous situation which, if not avoided, may result in property damage.

 **NOTICE** NOTICE indicates special instructions on installation, operation, or maintenance that are important but not related to personal injury or property damage.

Please read before proceeding

WARNING

Installer – Read all instructions, including this manual and the Crest Installation and Operation Manual, before installing. Perform steps in the order given.

User – This manual is for use only by a qualified heating installer/service technician. Refer to the Crest User's Information Manual for your reference.

Have this boiler serviced/inspected by a qualified service technician at least annually.

Failure to comply with the above could result in severe personal injury, death or substantial property damage.

NOTICE

When calling or writing about the boiler – Please have the boiler model and serial number from the boiler rating plate.

Consider piping and installation when determining boiler location (see the Crest Installation and Operation Manual).

Any claims for damage or shortage in shipment must be filed immediately against the transportation company by the consignee.

Handling ceramic fiber materials

REMOVAL OF COMBUSTION CHAMBER LINING

WARNING

The combustion chamber insulation in this appliance contains ceramic fiber material. Ceramic fibers can be converted to cristobalite in very high temperature applications. The International Agency for Research on Cancer (IARC) has concluded, "Crystalline silica in the form of quartz or cristobalite from occupational sources is carcinogenic to humans (Group 1)." Normal operating temperatures in this appliance are below the level to convert ceramic fibers to cristobalite. Abnormal operating conditions would have to be created to convert the ceramic fibers in this appliance to cristobalite.

The ceramic fiber material used in this appliance is an irritant; when handling or replacing the ceramic materials it is advisable that the installer follow these safety guidelines.

- Avoid breathing dust and contact with skin and eyes.
 - Use NIOSH certified dust respirator (N95). This type of respirator is based on the OSHA requirements for cristobalite at the time this document was written. Other types of respirators may be needed depending on the job site conditions. Current NIOSH recommendations can be found on the NIOSH website at <http://www.cdc.gov/niosh/homepage.html>. NIOSH approved respirators, manufacturers, and phone numbers are also listed on this website.
 - Wear long-sleeved, loose fitting clothing, gloves, and eye protection.
- Apply enough water to the combustion chamber lining to prevent airborne dust.
- Remove the combustion chamber lining from the appliance and place it in a plastic bag for disposal.
- Wash potentially contaminated clothes separately from other clothing. Rinse clothes washer thoroughly.

NIOSH stated First Aid.

- Eye: Irrigate immediately.
- Breathing: Fresh air.

Please read before proceeding

When servicing boiler –

- To avoid electric shock, disconnect electrical supply before performing maintenance.
- To avoid severe burns, allow boiler to cool before performing maintenance.

Boiler operation –

- Do not block flow of combustion or ventilation air to the boiler.
- Should overheating occur or gas supply fail to shut off, do not turn off or disconnect electrical supply to circulator. Instead, shut off the gas supply at a location external to the appliance.
- Do not use this boiler if any part has been under water. The possible damage to a flooded appliance can be extensive and present numerous safety hazards. Any appliance that has been under water must be replaced.

Boiler water –

- Thoroughly flush the system (without boiler connected) to remove sediment. The high-efficiency heat exchanger can be damaged by build-up or corrosion due to sediment.
- Do not use petroleum-based cleaning or sealing compounds in the boiler system. Gaskets and seals in the system may be damaged. This can result in substantial property damage.
- Do not use “homemade cures” or “boiler patent medicines”. Serious damage to the boiler, personnel, and/or property may result.
- Continual fresh make-up water will reduce boiler life. Mineral buildup in the heat exchanger reduces heat transfer, overheats the stainless steel heat exchanger, and causes failure. Addition of oxygen carried in by makeup water can cause internal corrosion. Leaks in boiler piping must be repaired at once to prevent the introduction of makeup water.

Freeze protection fluids –

- NEVER use automotive antifreeze. Use only inhibited propylene glycol solutions which are specifically formulated for hydronic systems. Ethylene glycol is toxic and can attack gaskets and seals used in hydronic systems.

What is in this manual?

Service

Near boiler piping

- Typical system components

The Crest boiler display

- Display panel readout, buttons and their functions

Control module inputs

- Control module inputs and options

Control module outputs

- Control module outputs and options

General

- How the boiler operates
- How the control module operates
- Access modes -- user and installer
- Sequence of operation -- DHW/space heating

Control panel menu access

- Accessing programming mode and locating menus
(See separate guide covering the PC interface.)

Control panel parameter access

- Accessing and changing parameters from the display panel

Quick start information -- parameter table

- An index of available adjustments and readouts, where to access them and where to find detailed information.

Crest boiler operation

- Initial Setup
- Set Points
- Outdoor Reset
- Ramp Delay
- BMS
- Advanced Setup
- SH Night Setback
- DHW Night Setback
- Cascade
- Pumps

Maintenance

- Service and maintenance schedules
- Address reported problems
- Inspect boiler area and boiler interior
- Clean condensate trap
- Check all piping for leaks
- Check air openings
- Flue vent system and air piping
- Check water system
- Check expansion tank
- Check boiler relief valve
- Inspect ignition electrode
- Check ignition ground wiring
- Check all boiler wiring
- Check control settings
- Perform start-up and checks
- Check burner flame
- Check flame signal
- Check flue gas temperature
- General maintenance
- Review with owner
- Cleaning boiler heat exchanger
- Oiled bearing circulators
- Check/replace filter

Troubleshooting

- Troubleshooting table - No display
- Checking temperature sensors
- Sensor tables
- Troubleshooting table - Fault messages displayed on boiler interface
- Combustion analysis procedure
- Gas valve adjustment procedure

1 Service

Boiler piping

This piping reference is included to specify the *Boiler Piping* specific to the Crest boiler. This piping scheme is important for proper operation of the SMART TOUCH control. See the Crest Installation and Operation Manual for more detailed piping diagrams.

Single Boiler - Recommended - Primary / Secondary Piping with a Hot Water Generator

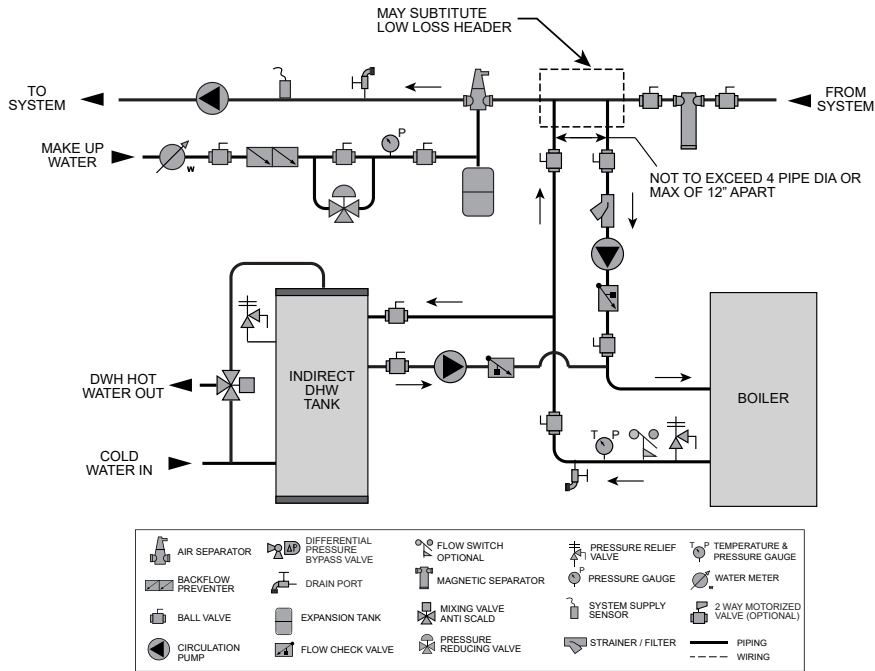

DIR #2000559501 01

Single Boiler - Alternate - Full Flow System Piping

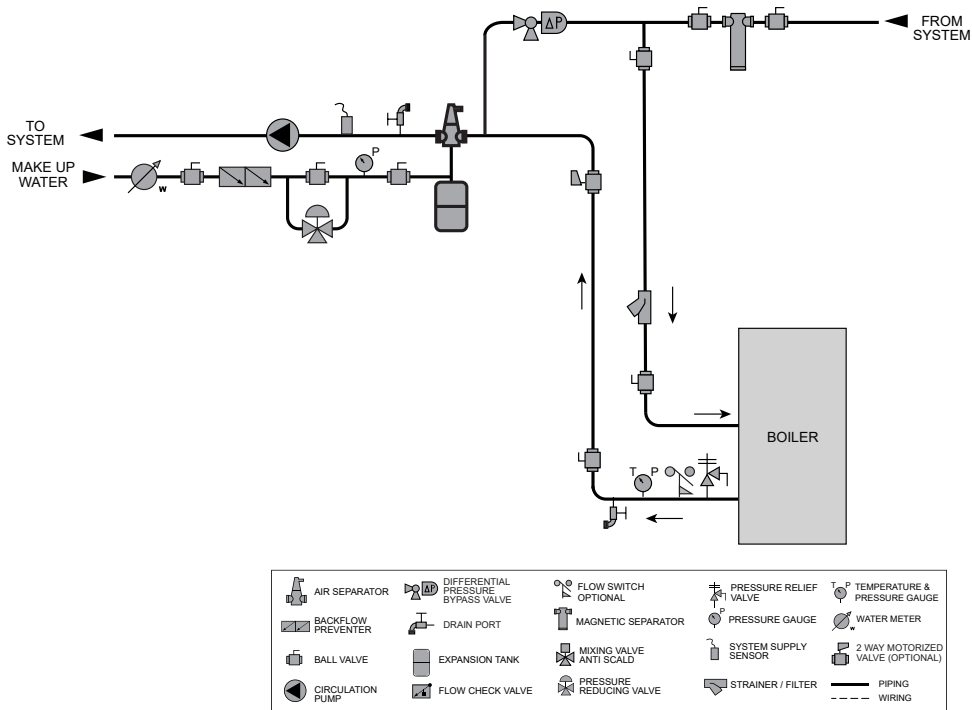

DIR #2000598465 00

1 Service *(continued)*



The Home Screen displays the available basic system information divided into the following sections: Status, Demand, Modulation, Sensors, and Navigation.

Figure 1-1 Home Screen

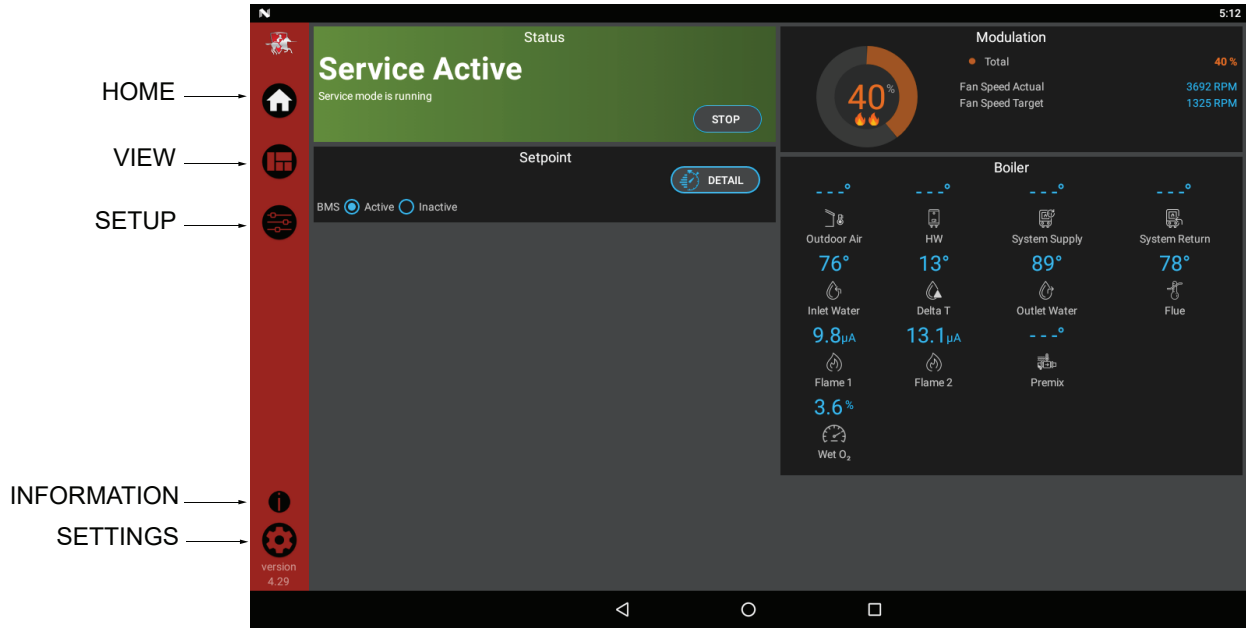

- The **Status** Section is located on the top left of the screen and displays how the unit is currently running (i.e. Off, Stand-by, Blocking, and Lockout) including: current driving demand, the next Hot Water Setback scheduled, the reason for any blocking or lockout, and a power button.
- The **Setpoint Demand** Section is located on the bottom left of the screen and displays information about the targets and limits of the current demand being serviced.
- The **Modulation** Section is located on the top right of the screen and displays the target modulation of the unit. This section also includes target and actual fan speeds.
- The **Boiler Sensor** Section is located on the bottom right of the screen and displays both factory installed and field installed sensor including: Outdoor Air, Hot Water Temperature, System Supply, System Return, Inlet Water, Delta T, Outlet Water, Flue Temperature, and Flame Current.
- The **Navigation** Section is located down the left side of the screen. There are five (5) sections located below the Lochinvar icon: Home, View, Setup, Information (About), and Settings. The Home Section is the screen shown above. The View Section provides more detailed information including subsections for: History, Cascade, Graphing, and a complete list of current Sensor Values. The Setup Section has several screens to aid in setting up the appliance. The Setup Section includes screens for adjusting: Set Points, Pump Settings, Cascade, BMS, Ramp Delay, and Night Setback. The Information Section provides information about the hardware and software including the current software version of the interface, the version of the boiler control, and the CON-X-US device serial number. The Setting Section enables several interface setup features including: Time Setup, Temperature Unit Select, Loch'n Link, System Update, and WiFi Setup.

1 Service

General Operation

How the boiler operates

The Crest uses an advanced stainless steel heat exchanger and an electronic control module that allows fully condensing operation. The blower pulls in air and pushes flue products out of the boiler through the heat exchanger and flue piping. The control modules regulate the firing rate of the boiler by adjusting blower speeds and valve positions to maintain the proper fuel air ratios.

How the control modules operate

The Crest boiler is equipped with a SMART TOUCH CON•X•US Interface. The control module receives inputs from boiler sensors and external devices. The control module activates and controls the blowers and gas valves to regulate heat input and switches the boiler, Hot Water Generator (DHW), and system pumps on and off as needed. The user programs the control module to meet system needs by adjusting control parameters through the SMART TOUCH CON•X•US Interface. These parameters set operating temperatures and boiler operating modes.

Sequence of operation

Table 1A (page 11) shows control module normal sequences of operation for space heating and DHW operation. The combined operation sequence is for a typical application, programmed to provide DHW priority.

Access modes

User

The USER can set the SH set point, DHW set point, turn the unit OFF and ON and set up WiFi.

Installer

Most parameters are available only to the INSTALLER, accessible only by entering the installer password (5309) when selecting the Setup Section.

Note: The password will timeout after an hour from entry.

1 Service *(continued)*

Control inputs

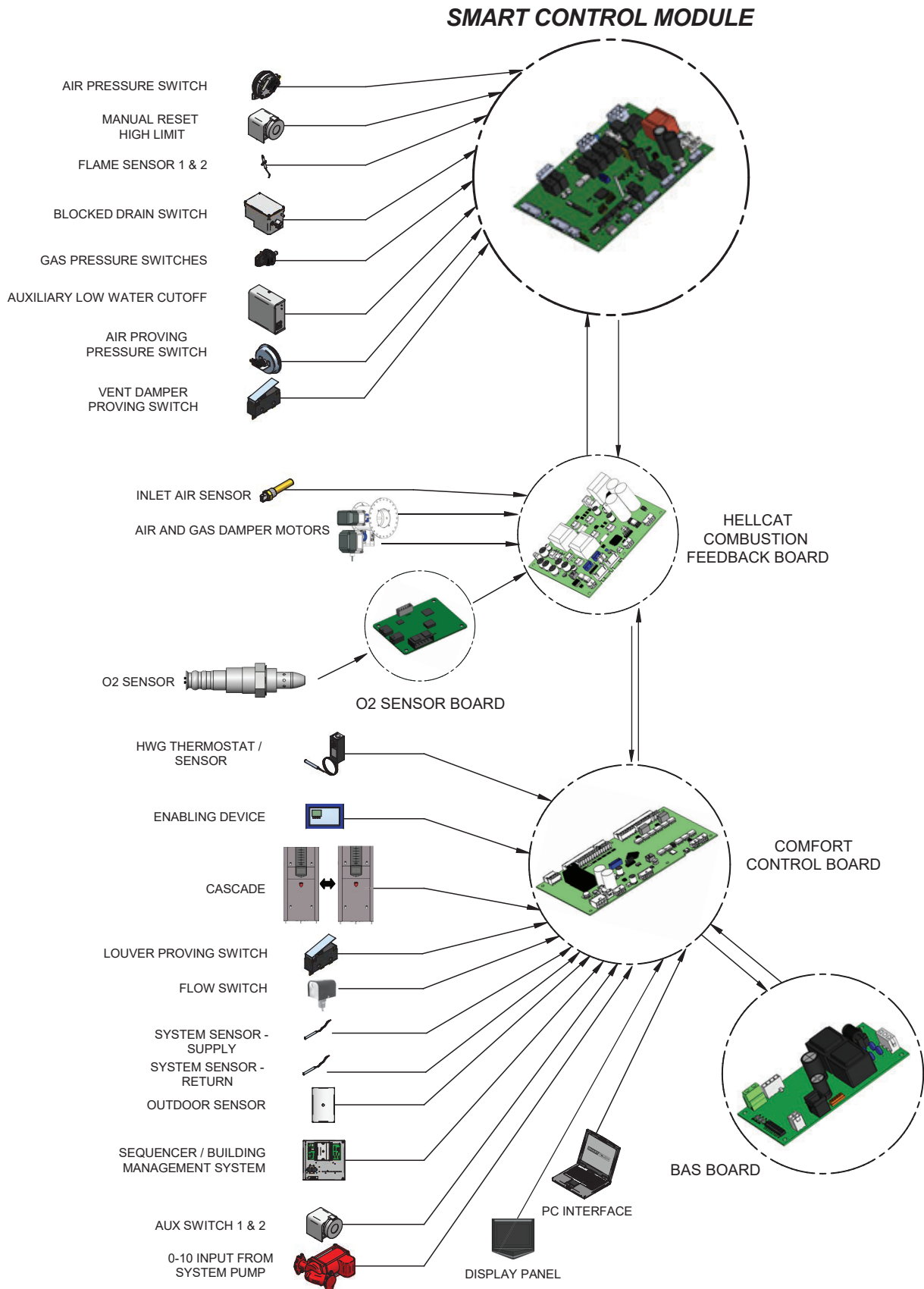

1 Service

Control outputs

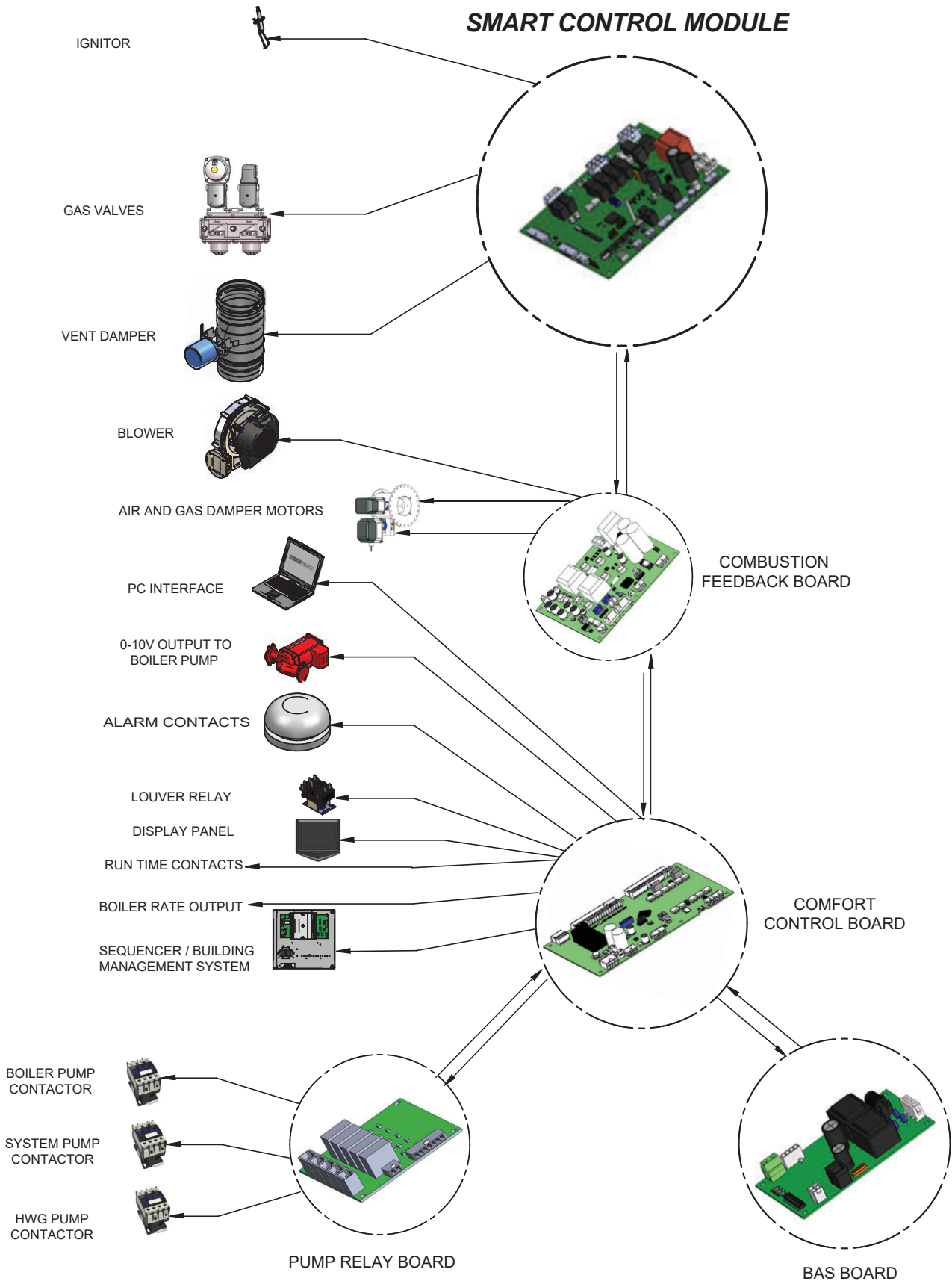

1 Service *(continued)*

Table 1A Sequence of Operation

Sequence of operation

1.	Upon a call for heat, the louver relay output will be closed initiating a block that will clear when the louver proving switch closes. Upon resolution of all blockings, the comfort control will send the demand to the boiler control.
2.	The boiler control initiates a pre-purge and confirms that all safeties are in their correct state. During the first part of the pre-purge, the air damper is wide open. The air damper APS is checked to be open. The proof of closure input is checked to be closed during this time.
3.	Once the air damper APS and proof of closure are confirmed, the safeties are checked in the correct state and the free air calibration is completed, the boiler control progresses to the second part of pre-purge. During this phase, the dampers and fan are controlled for the ignition state. During this phase, the air damper APS must become closed.
4.	The boiler control then proceeds to trial for ignition. First, the control begins sparking, then opens the gas valve. After sparking is complete, the control checks for the presence of a flame. If the flame is not detected, the control will recycle or lockout on an Ignition Flame Failure. If the flame is present, the control proceeds to the flame stabilization period. During the flame stabilization period, the flame signal must not drop below the detection threshold and further must raise to a sufficiently high level for a stable flame. If the flame does not reach the higher threshold during flame stabilization, the unit will recycle or lockout on Flame Loss While Running. During the flame stabilization period and any running state thereafter, the controls will check that the proof of closure input is open.
5.	Upon successful completion of the flame stabilization period, the control will proceed to the running state, and attempt to operate at the required modulation. At all times during operation, the damper positions and fan speed must remain within tolerance. Further, if an O2 sensor is present and functioning properly, the unit must operate within an expected range of O2. For operation below 10% modulation, the control will check that the air damper APS is in the closed state.
6.	If the current call for heat is for space heating and a DHW call for heat becomes active, the control will turn on the DHW pump relay output, then turn off the boiler pump. The control will then adjust modulation to maintain the outlet temperature to the desired DHW outlet setpoint temperature.
7.	The boiler will modulate as needed to reach the desired set point.
8.	Once both the space heating and DHW calls for heat are satisfied, the control will turn off the gas valve and begin the post-purge cycle. Any pumps that are running will begin their respective pump delay cycles.
9.	At the end of the post-purge cycle, the louver relay contacts will de-energize.
10.	After the fan speed falls below 3000 rpm, the air damper will be closed. The controls will check that the blower stops running and dampers are in their expected positions. The control will check that the air damper APS reaches the open state.
11.	After one (1) minute in standby, the O2 sensor will go into a standby state. At the end of the pump delay cycle(s), the pump(s) will be turned off.

1 Service

Initial Setup Screen

Figure 1-2 Settings Screen

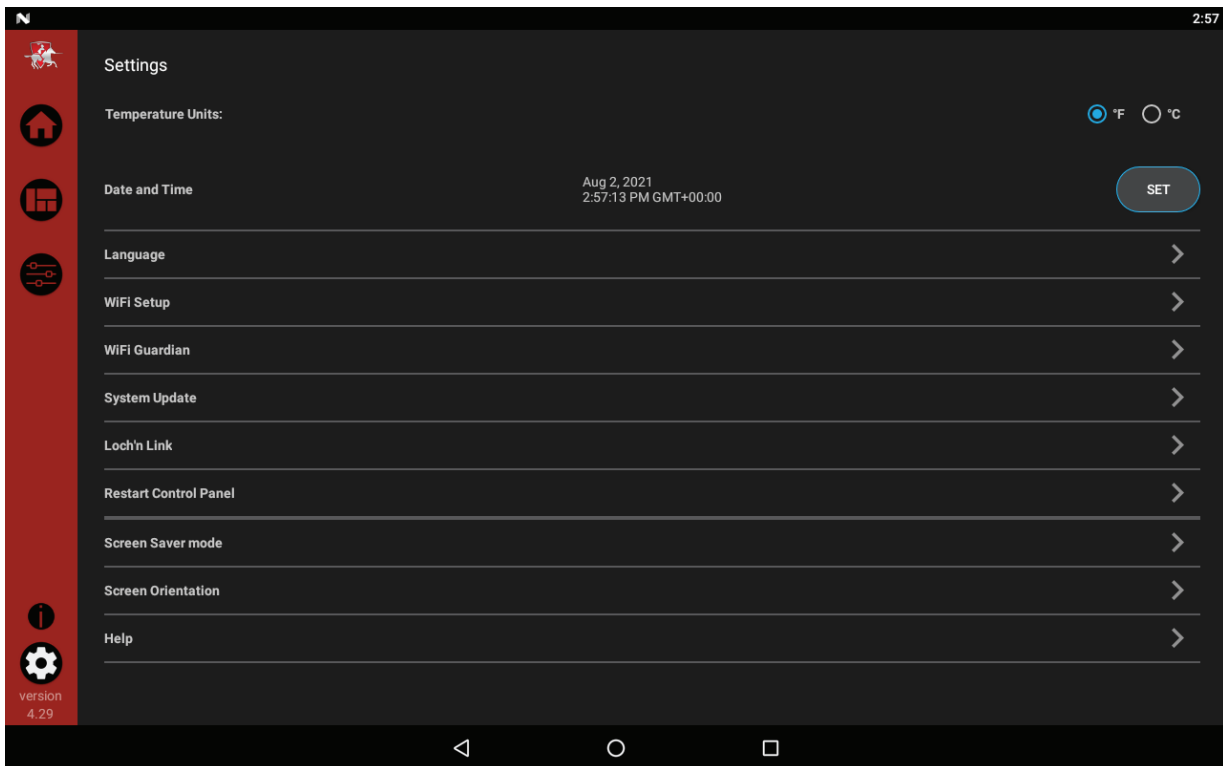

Initial Setup

Clock and Date

The control uses an internal clock for the night setback feature and for logging of events. For these features to work correctly, the clock must be set when the boiler is first installed or anytime the boiler has been powered off for more than four (4) hours. This parameter must be accessed to set the clock. If the unit is connected to the internet, the time will adjust based on the time zone selected.

Temperature units (°C / °F)

The control can be configured to display temperature in either °C or °F.

1 Service *(continued)*

Viewable and changeable control parameters

CAUTION Before changing parameters, note the settings so that the unit can be returned to its original operating parameters.

Set Point Screens

Figure 1-3 Set points DHW_Screen A

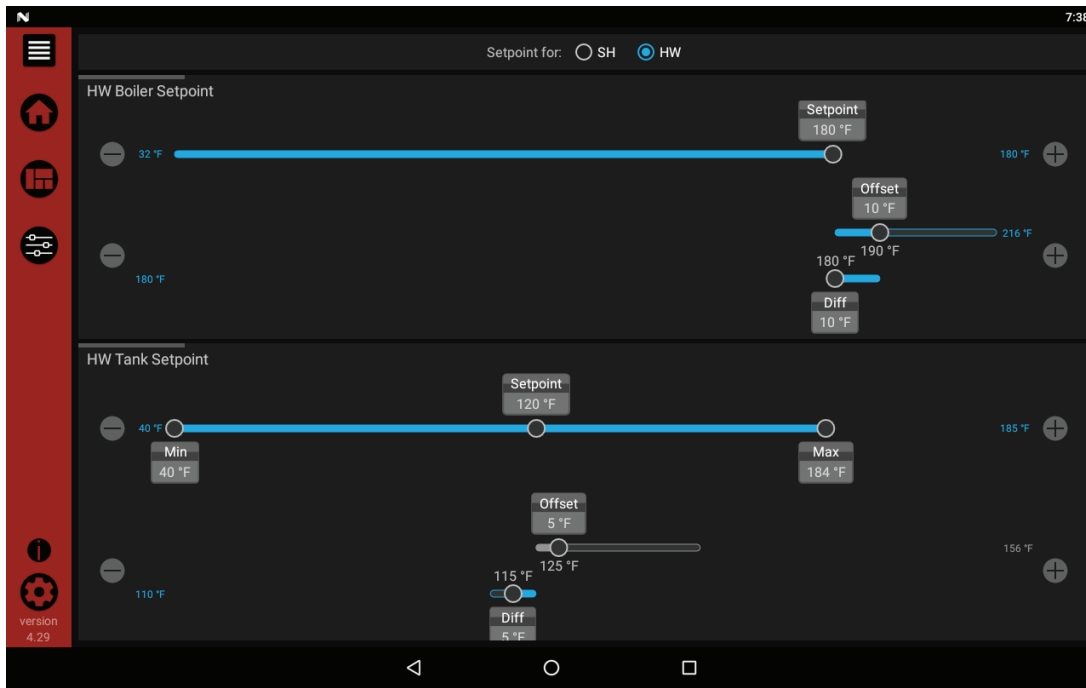
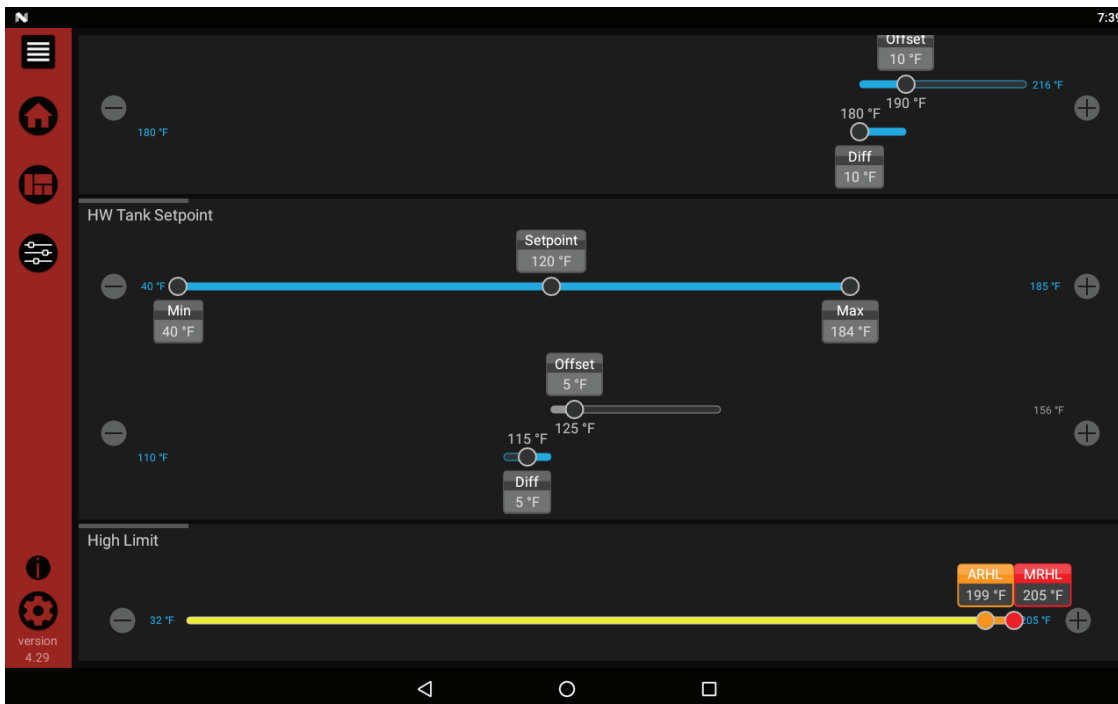

Figure 1-4 Set points DHW_Screen B



1 Service

Figure 1-5 Set points SH_Screen A

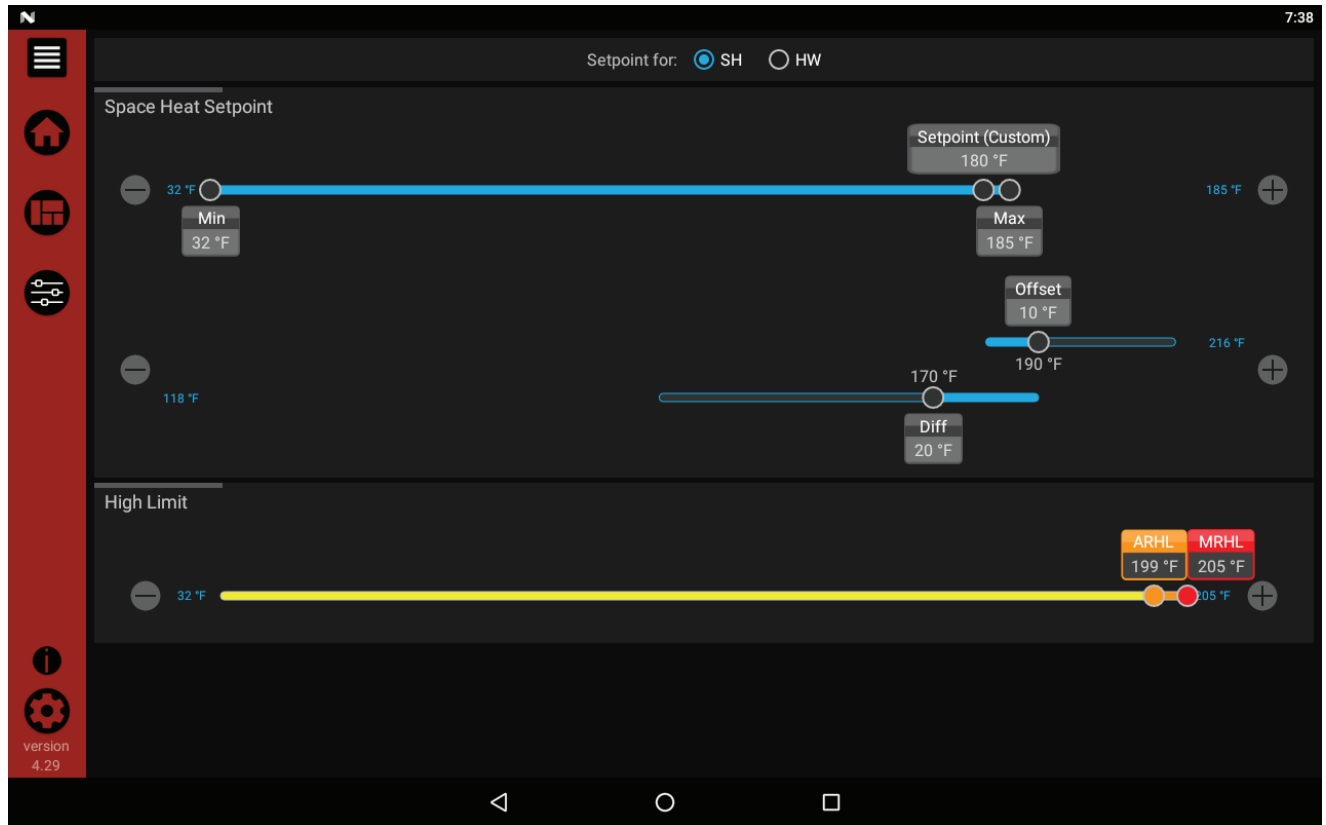

Table 1B Set Points (This table lists control module parameters; use the sub-tab under the Setup tab to access them.)

Menu	Parameter Name (as shown on the LCD screen)	Min	Max	Default
		Value	Value	Value
SET POINTS	Space Heat 1 Set point: Set point	32	185	120
	Space Heat 1 Set point: Min	32	185	32
	Space Heat 1 Set point: Max	32	185	185
	Space Heat 1 Set point: Offset	0	36	10
	Space Heat 1 Set point: Diff	0	72	20
	System Pump Anti-Seize Time	0	21	20
	High Limit: ARHL	32	200	199
	High Limit: MRHL	32	205	205
	DHW Boiler Set point: Set point	32	185	180
	DHW Boiler Set point: Offset	0	36	10
	DHW Boiler Set point: Differential	0	10	20
	DHW Tank Set pont: Set point	32	185	120
	DHW Tank Set point: Min	40	185	100
	DHW Tank Set point: Max	40	185	130
DHW Tank Set point: Diff	0	10	5	

1 Service *(continued)*

Set Points

Space Heat 1 Set Point: Set point

The SH set point sets the water temperature set point used during space heating calls.

Space Heat 1 Set Point: Min

The SH minimum set point determines the minimum value to which a user can adjust the Space Heat 1 set point without using the installer password. Note that with Outdoor Reset, BMS, and other control modes, the actual Space Heat set point can go below this value.

Space Heat 1 Set Point: Max

The SH maximum set point determines the maximum value to which a user can adjust the Space Heat 1 Set Point without using the installer password. Note that there are scenarios when a boiler outlet temperature or even active set point can exceed this value.

NOTICE

The SH maximum set point does not serve as a functional operating limit to the appliance. This setting only limits what adjustment a user can make without the installer password. If a certain application requires a hard limit on water temperature, the ARHL or MRHL features should be used.

Space Heat 1 Set Point: Offset

The SH offset sets how many degrees above set point the temperature can go before the boiler will shut off.

Space Heat 1 Set Point: Differential

The SH differential sets how many degrees below the offset the temperature has to drop before the boiler turns back on.

High Limit: ARHL

The SMART TOUCH control contains an integral Auto Reset High Limit (ARHL) on the outlet of the heat exchanger. Once the outlet temperature exceeds the ARHL set point, the boiler will shut down and lock out. Once the outlet temperature has dropped below this set point, the RESET button on the LCD display can be pressed to reset this lockout. If RESET is not pressed, the control will attempt to automatically reset the lockout after 15 minutes.

High Limit: MRHL

The SMART TOUCH control contains an integral Manual Reset High Limit (MRHL) on the outlet of the heat exchanger. Once the outlet temperature exceeds the MRHL set point, the boiler will shut down and lock out. Once the outlet temperature has dropped below this set point, the RESET button on the LCD display must be pressed to clear this lockout.

DHW Boiler Set Point: Set point

When a DHW call for heat becomes active, the control will use the DHW boiler set point to determine the firing rate of the boiler based on the boiler outlet water temperature or the system supply sensor depending on the DHW configuration (Normal or Zone).

DHW Boiler Set Point: Offset

This parameter reflects the degrees above DHW boiler set point the outlet temperature can go before the boiler will shut off.

DHW Boiler Set Point: Differential

This parameter reflects the degrees below DHW boiler offset the outlet temperature has to go before the boiler turns on.

DHW Tank Set Point: Set Point

By installing a tank sensor, the SMART TOUCH control can perform the tank thermostat function. The SMART TOUCH control automatically detects the presence of this sensor, and generates a call for heat when the tank temperature drops below the tank set point minus the differential, and finishes the call for heat when the tank temperature reaches tank set point.

DHW Tank Set Point: Min

This setting controls the minimum user set point for the tank temperature.

NOTICE

DHW Tank Set Point: Min setting does not constitute a minimum possible temperature of the tank, but rather a minimum allowable value of the DHW Tank Set Point that can be applied without the installer password.

DHW Tank Set Point: Max

This setting controls the maximum user set point for the tank temperature.

CAUTION

The DHW Tank Set Point: Max setting does not constitute a maximum possible temperature of the DHW tank. Proper scald protection is required regardless of the value of this setting.

DHW Tank Set Point: Differential

When a tank sensor is installed, the tank temperature must drop this amount below the tank set point before the boiler will turn on.

1 Service

Outdoor Reset Screen

Figure 1-6A Outdoor Reset A

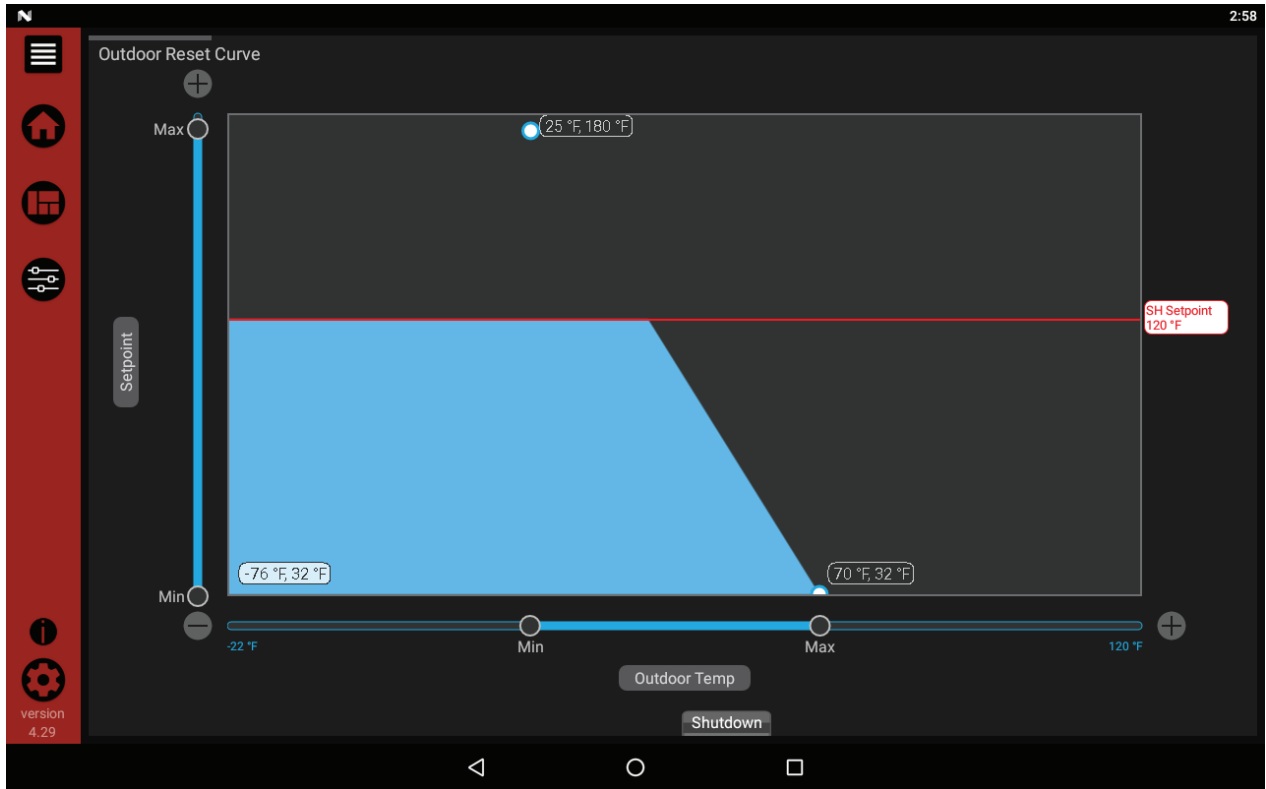
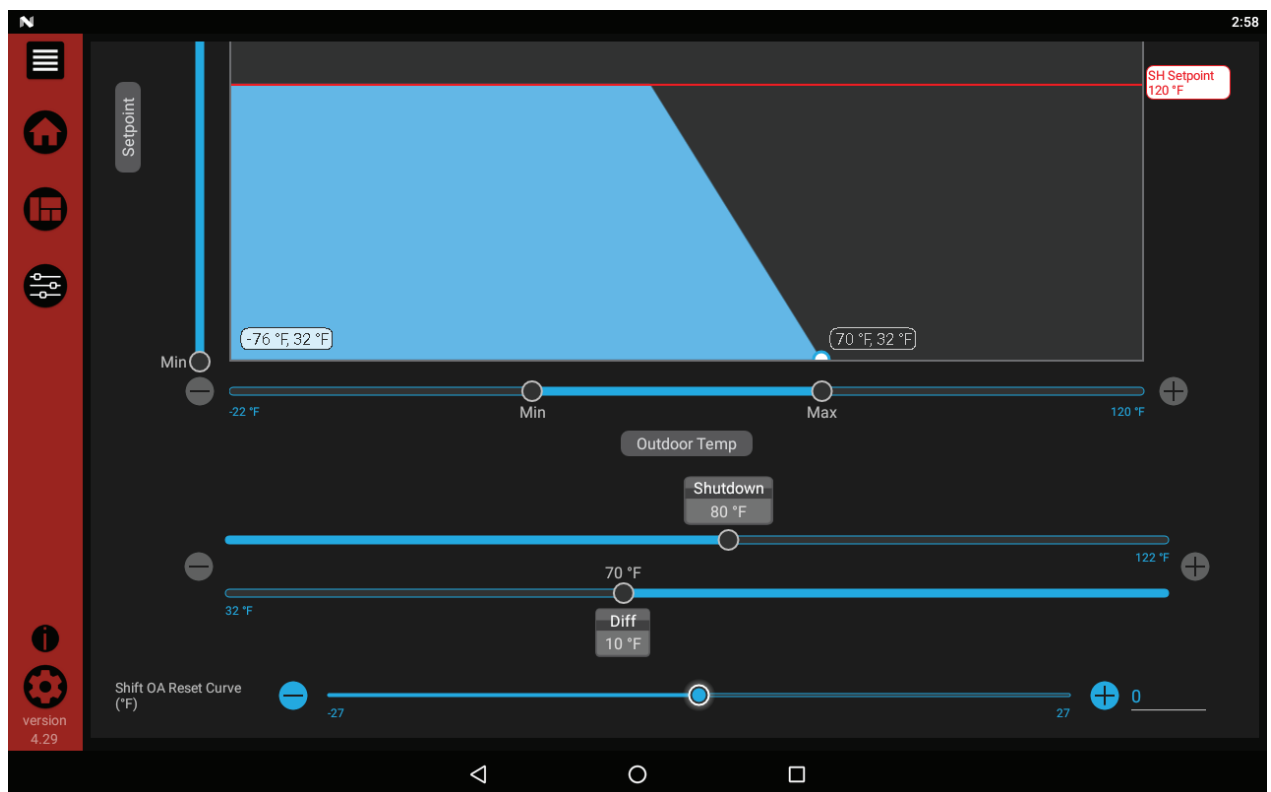

Figure 1-6B Outdoor Reset B



1 Service *(continued)*

Table 1C Outdoor Reset (This table lists control module parameters; use the sub-tab under the Setup tab to access them.)

Menu	Parameter Name (as shown on the LCD screen)	Min	Max	Default
		Value	Value	Value
OUTDOOR RESET	Set point: Cold Day	32	185	180
	Set point: Warm Day	32	185	110
	Outdoor Temperature: Cold Day	-22	120	25
	Outdoor Temperature: Warm Day	-22	120	70
	Outdoor Temp: Shutdown	32	122	80
	Outdoor Temp: Diff	0	48	10
	Shift OA Reset Curve	-27	27	0
	Boost Time	0	250	0
	Boost Temperature	0	30	0

Outdoor Reset

Outdoor Reset Curve

The Outdoor Temp Min and Set Point Max define the upper point of the Outdoor Reset Curve. The lower point is defined by the Outdoor Temp Max and Set Point Min. The curve will level out at Set Point Min for temperature warmer than Outdoor Temp Max. The Space Heat 1 Set Point (User Set Point) will serve as the maximum set point generated by the Outdoor Reset, regardless if this value is higher or lower than Set Point Max. The curve will continue increasing set point above Set Point Max as the outdoor temperature falls lower than the Outdoor Temp Min if the User Set Point is higher than the Set Point Max. The curve will be shortened such that the outdoor reset set point will not reach Set Point Max in case the User Set Point is below Set Point Max. In this case, the maximum set point will be achieved at some outdoor temperature higher than Outdoor Temp Min.

Outdoor Temperature: Shutdown

When the outdoor temperature rises above this point, the control will block all SH demands (DHW demands will still be active).

Outdoor Temperature: Differential

The outdoor temperature differential parameter is the number of degrees the outside air temperature must fall below the outdoor shutdown parameter setting before the boiler will respond to a SH demand.

Shift OA Reset Curve

The shift reset curve parameter shifts the actual set point above or below the calculated set point by the number of degrees in this parameter.

Boost Time

The boost time parameter sets the amount of time that must elapse with a SH demand before the water temperature calculated set point will be increased.

Boost Temperature

If a SH demand lasts longer than the programmed boost time delay setting and there have been no DHW demands, the control will increase the water temperature set point by the amount in this parameter. If the SH demand continues through another time period, the set point will be increased again. This will continue until either the SH demand ends, a maximum of 20 increases has occurred, or the maximum set point has been reached. Once the SH demand has been satisfied the set point will revert back to its calculated setting.

1 Service

Ramp Delay Screen

Figure 1-7A Ramp Delay

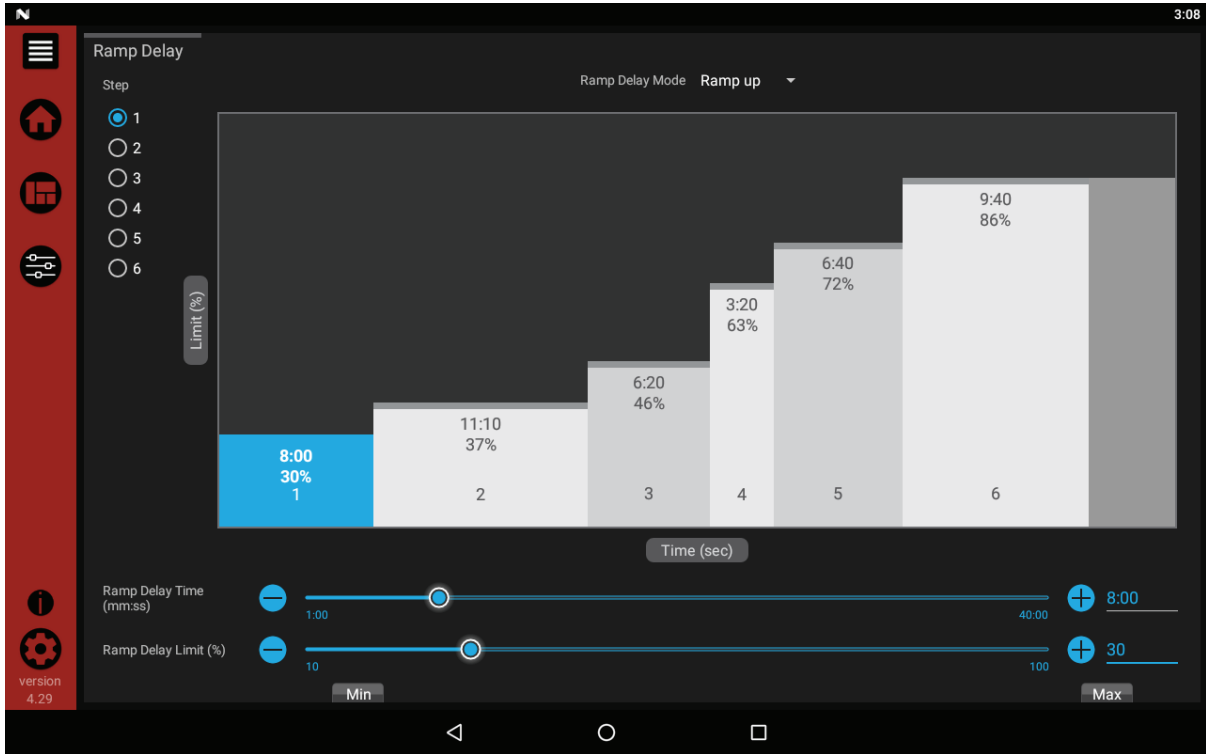
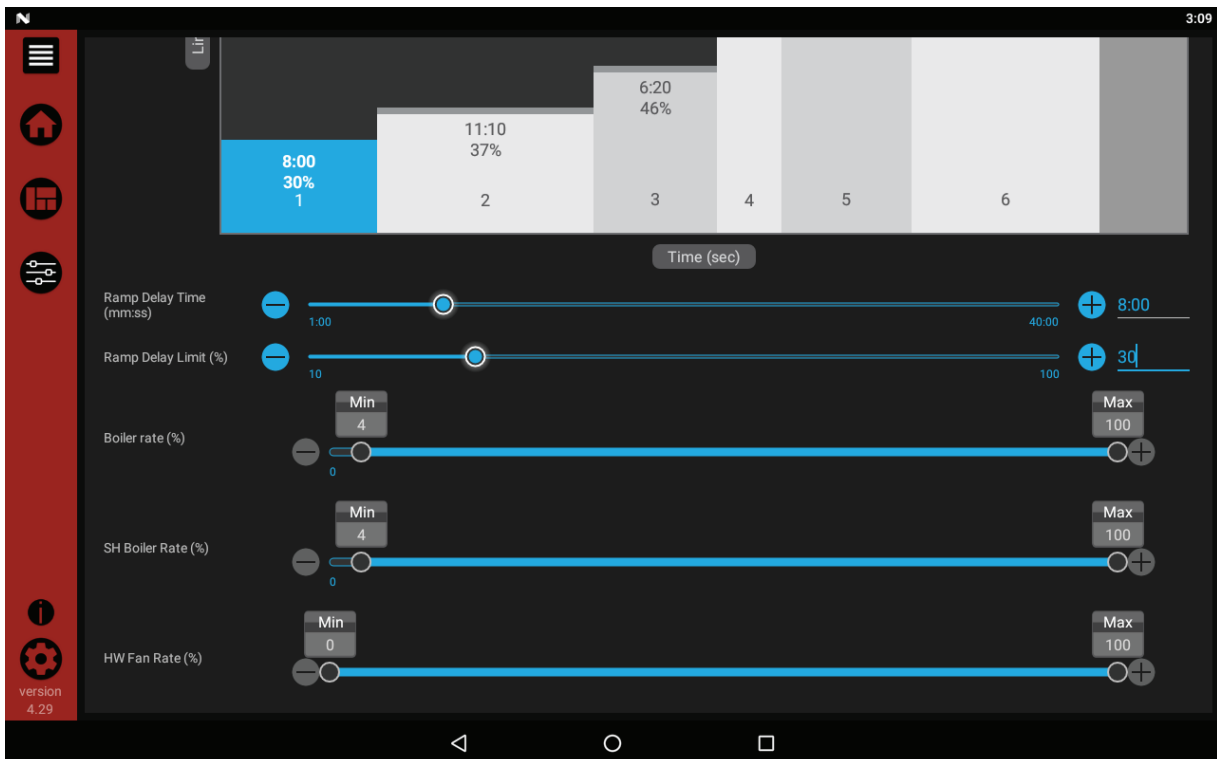

Figure 1-7B Ramp Delay



1 Service *(continued)*

Table 1D Ramp Delay (This table lists control module parameters; use the sub-tab under the Setup tab to access them.)

Menu	Parameter Name (as shown on the LCD screen)	Min	Max	Default
		Value	Value	Value
RAMP DELAY	Ramp Delay Mode	N/A	N/A	N/A
	Step 1: Ramp Delay Time	0	40	2
	Step 1: Ramp Delay Limit (%)	LF	100	15
	Step 2: Ramp Delay Time	0	40	1
	Step 2: Ramp Delay Limit (%)	LF	100	30
	Step 3: Ramp Delay Time	0	40	1
	Step 3: Ramp Delay Limit (%)	LF	100	45
	Step 4: Ramp Delay Time	0	40	1
	Step 4: Ramp Delay Limit (%)	LF	100	60
	Step 5: Ramp Delay Time	0	40	1
	Step 5: Ramp Delay Limit (%)	LF	100	75
	Step 6: Ramp Delay Time	0	40	1
	Step 6: Ramp Delay Limit (%)	LF	100	100

Ramp Delay

Ramp Delay (Enable / Disable)

This parameter allows the installer to enable or disable the SH ramp delay.

SH Ramp Delay

The SMART TOUCH CON•X•US Interface can be programmed to limit the target firing rate for a fixed period of time at the start of a space heating demand. There are six (6) possible limits, each with their own time delay. The first limit applies as soon as the burner starts. Once its time delay expires, the second limit is applied and its timer begins. The control steps through these limits until the 6th (sixth) limit expires, at which point SH Ramp Delay will no longer limit modulation.

Boiler Rate (%)

This parameter setting will define the minimum and maximum modulation of the boiler during normal operation. Boiler rate settings can be useful to limit high fire rate to increase the run times to reduce short cycling or to limit turndown for sites having minimum requirements for processing temperatures. **Note:** When commissioning or servicing the boiler, the minimum and maximum rate settings need to be set to their lowest and highest settings, respectively. This ensure the boiler has the full range of operation needed for commissioning and servicing the boiler.

SH Boiler Rate (%)

This parameter setting will define the minimum and maximum modulation for space heat demand.

DHW Fan Rate (%)

This parameter setting will set the minimum and maximum fan rates during hot water demands.

Note: Ramp Delay, Boiler Rate, SH Boiler Rate, or DHW Fan Rate, all serve to limit the minimum and maximum rate percentage settings, but they do not have assigned priorities. The overall modulation rate is determined by mode (SH / DHW / Ramp Delay / BMS / etc.), system setpoint(s), and boiler rate min/max limits in conjunction with the current operating conditions which could require a higher modulation rate to boost a weak flame signal or a lower modulation to reduce temperatures to avoid tripping the Manual Reset High Limit (MRHL).

1 Service

BMS Screens

Figure 1-8 BMS_Screen A

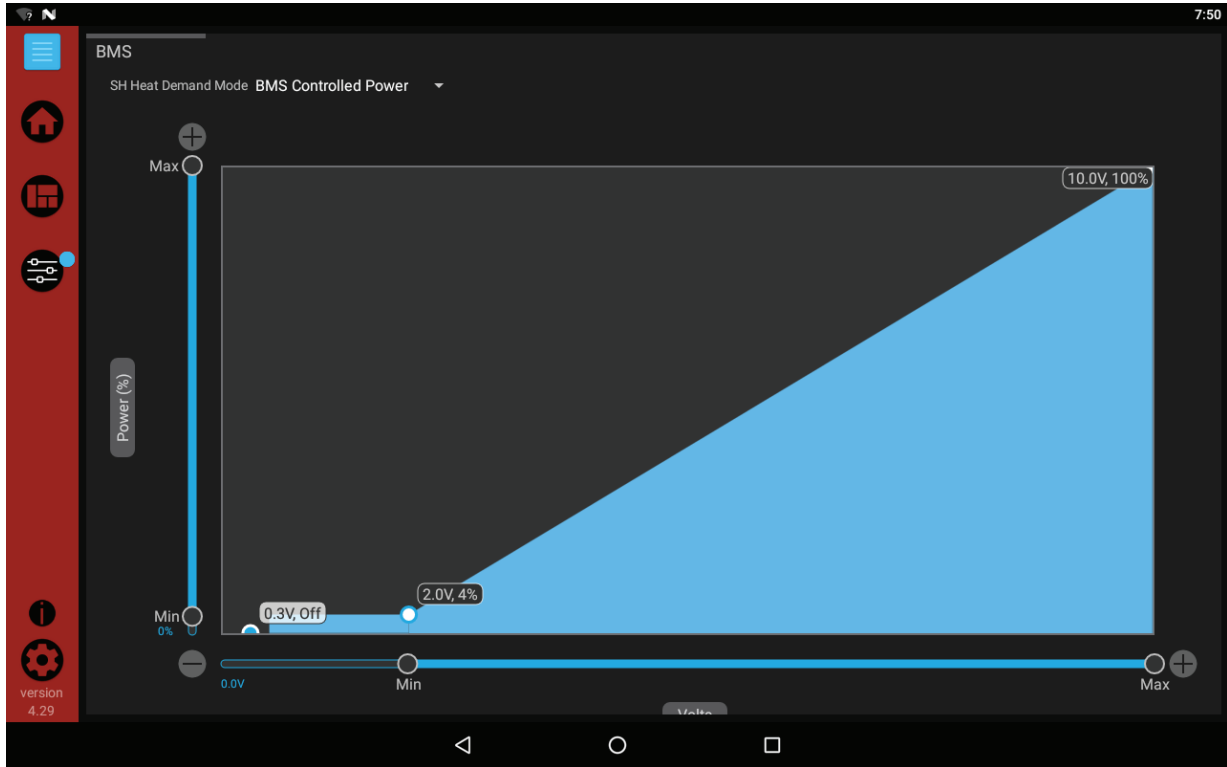
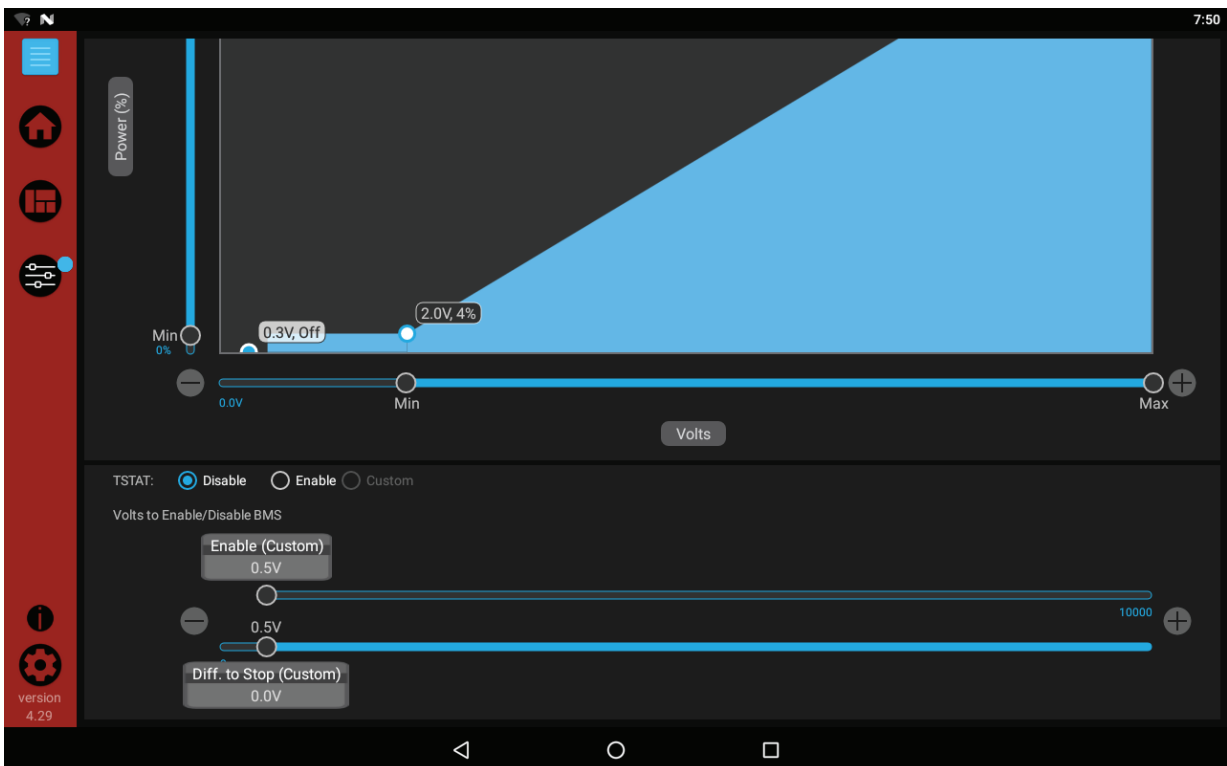

Figure 1-9 BMS_Screen B



1 Service *(continued)*

Table 1E BMS / BAS (This table lists control module parameters; use the sub-tab under the Setup tab to access them.)

Menu	Parameter Name (as shown on the LCD screen)	Min	Max	Default
		Value	Value	Value
BMS	BMS Status	ACTIVE	INACTIVE	INACTIVE
	BMS Mode	POWER	SETPOINT	POWER
	Power (%): Min	4	POWER MAX	4 or 5
	Power (%): Max	POWER MIN	100	100
	Volts: Min	0	VOLTS MAX	2
	Volts: Max	VOLTS MIN	10	10
	Set point (F): Min	32	SET POINT MAX	69.8
	Set point (F): Max	SET POINT MIN	185	179.6
	Volts: Min	0	VOLTS MAX	2
	Volts: Max	VOLTS MIN	10	10
	Volts to Enable / Disable BMS: Enable	0	10	2
	Volts to Enable / Disable BMS: Diff. to Stop	0	10	0.5
	BMS TSAT	ENABLE	DISABLE	DISABLE
	BAS	BAS Active / Inactive	ENABLE	DISABLE
BAS Out of Order Timer		5	120	30

BMS

BMS (Active / Inactive)

The set point or modulation of the boiler may be controlled through the 0 - 10V Building Management System (BMS) input. When the parameter is set to INACTIVE, the 0 - 10V input will be ignored. When set to ACTIVE, the set point or modulation will be controlled by the voltage on the 0 - 10V input, as described below.

BMS Mode (Power / Set Point)

When BMS is set to ACTIVE, this parameter will determine if the voltage on the 0 - 10V BMS input is converted to modulation or a set point. When set to POWER, the voltage determines the modulation of the boiler. When set to SETPOINT, voltage determines the set point used by the boiler.

BMS Volts at Minimum (Power or Set Point)

When BMS is set to ACTIVE, this parameter will determine the voltage on the 0 - 10V BMS input that represents the minimum modulation or set point. Any voltage less than this value will not change the modulation or set point used by the boiler.

BMS Volts at Maximum (Power or Set Point)

When BMS is set to ACTIVE, this parameter will determine the voltage on the 0 - 10V BMS input that represents the maximum modulation or set point. Any voltage above this value will not change the modulation or set point used by the boiler.

BMS Rate at Minimum Volts

This parameter is visible only when BMS Mode is set to POWER. The value of this parameter determines the modulation rate when the voltage on the 0 - 10V BMS input is equal to or less than the BMS Volts at Minimum parameter value.

BMS Rate at Maximum Volts

This parameter is visible only when BMS Mode is set to POWER. The value of this parameter determines the modulation rate when the voltage on the 0 - 10V BMS input is equal to or more than the BMS Volts at Maximum parameter value.

1 Service

BMS Set Point at Minimum Volts

This parameter is visible only when the BMS Mode is set to SETPOINT. The value of this parameter determines the set point when the voltage on the 0 - 10V BMS input is equal to or less than the BMS Volts at Minimum parameter value.

BMS Set Point at Maximum Volts

This parameter is visible only when BMS Mode is set to SETPOINT. The value of this parameter determines the set point when the voltage on the 0 - 10V BMS input is equal to or more than the BMS Volts at Maximum parameter value.

BMS Volts to Enable

When BMS is set to ACTIVE, the boiler may be enabled either through the ENABLE input, or by the voltage on the 0 - 10V BMS input (see BMS Tstat Enable Mode below). If enabled through the voltage on the 0 - 10V BMS input, the value of this parameter determines the voltage at which the boiler becomes enabled.

Differential to Stop BMS Demand

When BMS is set to ACTIVE, and the boiler is enabled through the voltage on the 0 - 10V BMS input, the voltage must go below the BMS Volts to Enable value by this amount in order to end the demand.

BMS Tstat Enable Mode

In order to use the ENABLE input to enable the boiler, this parameter must be set to ACTIVE. To use the voltage on the 0 - 10V BMS input to enable the boiler, this parameter must be set to INACTIVE.

BAS

BAS Active / Inactive

The boiler is capable of being monitored and/or controlled by a Building Automation System (BAS) through either a ModBus RTU or BACnet MS/TP communication system. In addition, it can communicate through a BACnet TCP/IP system with the use of an optional gateway. See the Crest ModBus Manual (100161012) for details on the points that are available. If the boiler is to be monitored by the BAS system, the BAS Active / Inactive parameter should be set to INACTIVE. If the boiler is to be controlled through a BAS system, the BAS Active / Inactive parameter must be set to ACTIVE.

BAS Out of Order Timer

When the boiler is being controlled by the BAS system, the commands it sends to the boiler must be refreshed periodically. If the boiler does not receive a command for too long, the boiler will revert to its local readings (e.g., enable input, temperatures, etc.) until a new command is received from the BAS system. For most commands, this timeout is fixed at 10 minutes. Certain commands (0 - 10V BMS voltage, system supply temperature, system return temperature, and tank temperature) can change quickly, so they need to be refreshed more often. The timeout for these commands is controlled by the BAS Out of Order Timer.

1 Service *(continued)*

Advanced Setup Screen

Figure 1-10 Advanced Setup Screen

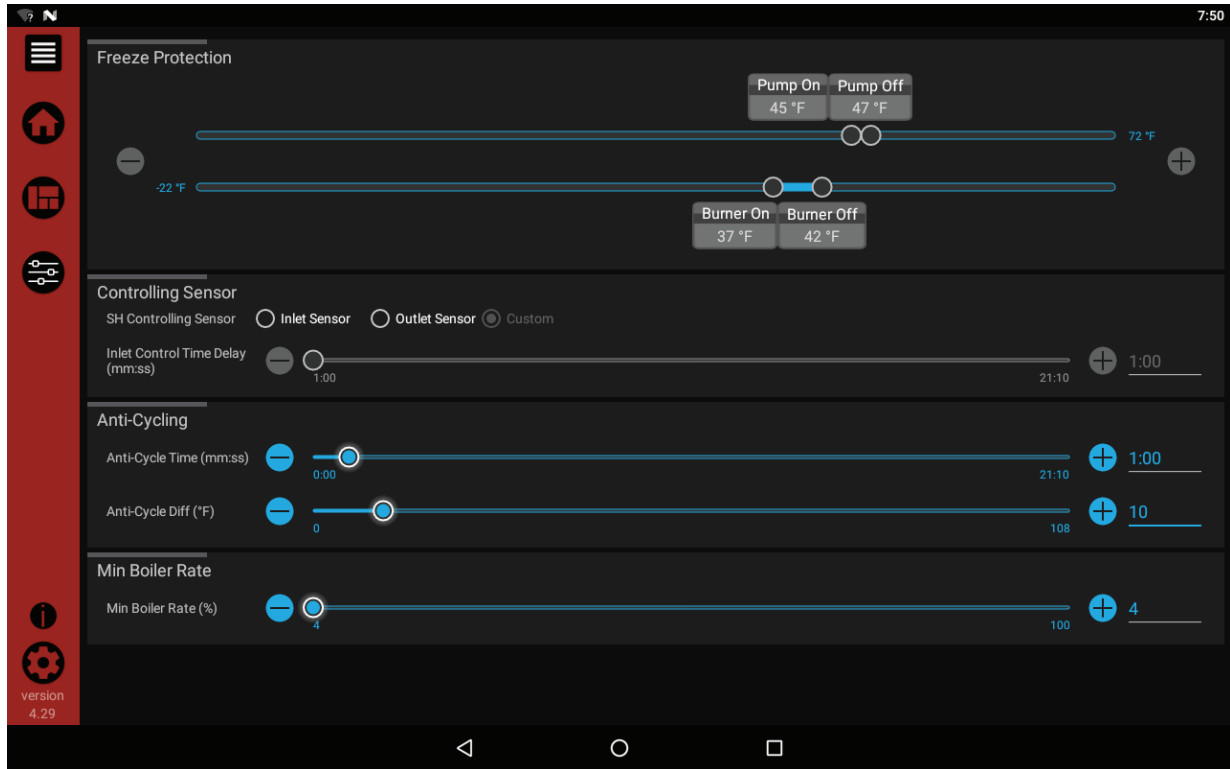

Table 1F Advanced Setup (This table lists control module parameters; use the sub-tab under the Setup tab to access them.)

Menu	Parameter Name (as shown on the LCD screen)	Min	Max	Default
		Value	Value	Value
ADVANCED SETUP	Freeze Protection; Pump On	-22	45	45
	Freeze Protection; Burner On	-22	45	37
	Freeze Protection; Burner Off	-22	45	5
	Anti-Cycling Time	0	40	10
	Anti-Cycling Diff	0	54	1
	Controlling Sensor	0	4	2
	Inlet Control Time Delay	0	21:10	0
	Minimum Boiler Rate (%)	MIN Modulation	100	MIN

1 Service

Advanced Setup

Freeze Protection Pump On

The SMART TOUCH control will turn on the boiler and system pump outputs whenever the inlet temperature drops below this setting. This is done to prevent the water in the heat exchanger from freezing. Certain low-temperature applications (such as snow melt) can operate at temperatures around freezing, so this setting needs to be lowered in these cases. The temperature at which the pump outputs are turned on, can be accessed through the Freeze Protection Pump On parameter.

Freeze Protection Burner Off

Once the burner has started firing due to a low inlet temperature, the inlet temperature must increase by this amount before the burner turns back off. The installer can adjust this differential by accessing the Freeze Protection Burner Off parameter.

Anti-Cycling Time

Once a SH demand has been satisfied, a set amount of time must elapse before the control will respond to a new SH demand. The control will block the new heat demand and anti-cycling will be shown in the display until the time has elapsed or the water temperature drops below the anti-cycling differential. This parameter can be changed by the installer by accessing the Anti-Cycling Time parameter.

Freeze Protection Burner On

If running the pumps does not prevent the inlet temperature from falling closer to freezing, the SMART TOUCH control will fire the burner at low fire if in the ON state. The installer can adjust the temperature at which the burner fires by adjusting the Freeze Protection Burner On parameter.

Anti-Cycling Differential

The control will bypass the anti-cycling time if the inlet water temperature drops too much. The control will use the inlet water temperature at the time the boiler shuts off as the starting point. If the inlet temperature drops below this temperature parameter the control will abort anti-cycling and allow the boiler to fire. This parameter can be changed by the installer by the Anti-Cycling Differential parameter.

Freeze Protection Burner On

If running the pumps does not prevent the inlet temperature from falling closer to freezing, the SMART TOUCH control will fire the burner at low fire if in the ON state. The installer can adjust the temperature at which the burner fires by adjusting the Freeze Protection Burner On parameter. the boiler firing rate. This parameter is adjustable by accessing the Controlling Sensor parameter. The sensor selections are as follows: The outlet sensor regulates the firing rate based on the outlet water temperature of the boiler and the inlet sensor regulates the firing rate based on the inlet water temperature of the boiler. If the outlet sensor is selected, and the optional system supply sensor is connected, the control will regulate the firing rate based on the system supply sensor temperature.

Inlet Control Time Delay

This parameter is the time allowed before the control switches from inlet to outlet control for space heating (SH).

Minimum Boiler Rate (%)

This parameter setting will define the minimum modulation of the boiler during normal operation.

1 Service *(continued)*

Night Setback Screen

Figure 1-11A SH Night Setback

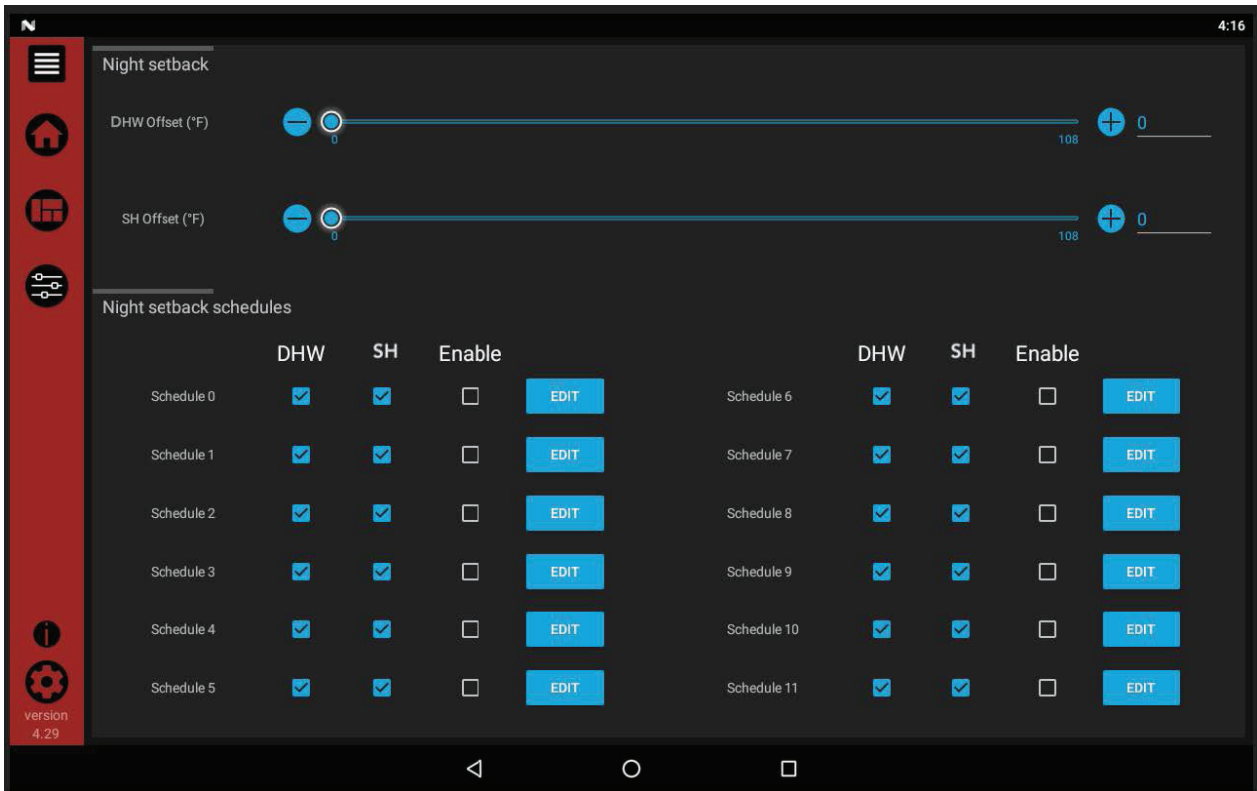

Table 1G DHW/SH Night Setback

Menu	Parameter Name (as shown on the LCD screen)	Min	Max	Default
		Value	Value	Value
DHW/SH NIGHT SETBACK	Offset Temperature (F)	0	90	0

Offset Temperature

Once the internal clock has been set correctly, the night setback feature can be used to program a lower set point. The value of this parameter will be subtracted from the normal set point to determine the set point used during night setback. The temperature range for this parameter is 0°F to 90°F (50°C). The feature is turned off with a setting of 0°F.

DWH/SH Night Setback Schedules

Night Setback allows DHW (domestic hot water) and SH (space heat) temperatures to be offset (lowered) during periods where the building is either unoccupied or seasonal use allows lower temperatures. Twelve schedules will allow the user to customize systems to maintain comfort while conserving energy during low-demand periods. Offsets can be scheduled for SH (space heat) or DHW (domestic hot water) settings either individually or together. From this screen you can enable/disable setbacks or press EDIT (FIG. 1-11A) to further customize schedules by month or day. If you enable or disable schedules from this screen, you will also need to apply the changes. The Menu drop-down and Setup/Configuration icons should be highlighted if changes are pending. Pressing the highlighted icon will show an option to APPLY or CLEAR changes. Pressing APPLY will allow the user to review changes prior to applying them. Pressing CANCEL will allow you to re-edit or clear the changes while pressing SEND will apply the changes.

- SH (Space Heat) is the set point for temperature used during space heating calls.
- DHW (Domestic Hot Water) is the set point used for temperature when heating water.

Figure 1-11B SH Night Setback Schedule

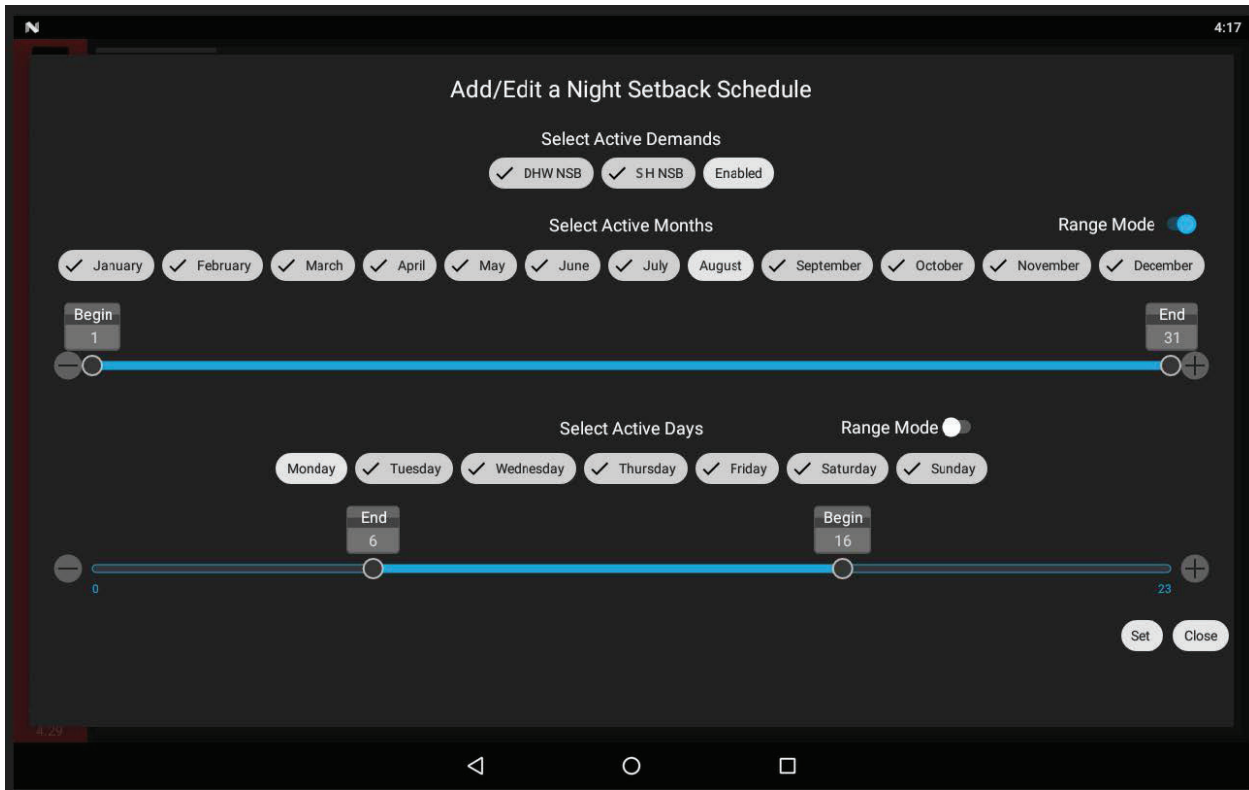

DWH/SH Night Setback Schedule Add / Delete

Active Months

Select or deselect active months by checking or unchecking the desired months. Slider or +/- can be used to select the beginning and ending dates.

Active Days

Select or deselect active weekdays by checking or unchecking desired days. Slider or +/- can be used to select ending or beginning weekdays.

Range Mode

Range Mode (enable/disable) toggles between individual and group scheduling. With Range Mode disabled, scheduling will begin and end within the individual month(s) checked on the begin and the end days selected. With Range Mode enabled, any checked adjacent months are grouped together, and scheduling will begin on the begin date of the first month and end on the end date of the last adjacent grouped month checked. When Range Mode is enabled, leaving a month unchecked between groupings will stop the scheduling for that month and resume with the next checked month. Range Mode function works the same for active days. The active button will be highlighted when enabled, reference the following examples:

Example for Active Months: Enabling Range Mode, checking March, April and May and then setting begin and end dates to 5 and 25, respectively, would begin the schedule on March 5th and end the schedule on May 25th.

Example for Active Days: Enabling Range Mode for Active Days and checking Monday, Tuesday and Wednesday with end/begin times set to 6 and 16, respectively, would end the offsets at 6 AM on Monday and begin the offset at 4PM Wednesday. A 24Hr time format is used for begin and end times.

1 Service *(continued)*

Pump Screen

Figure 1-12 Pump Screen

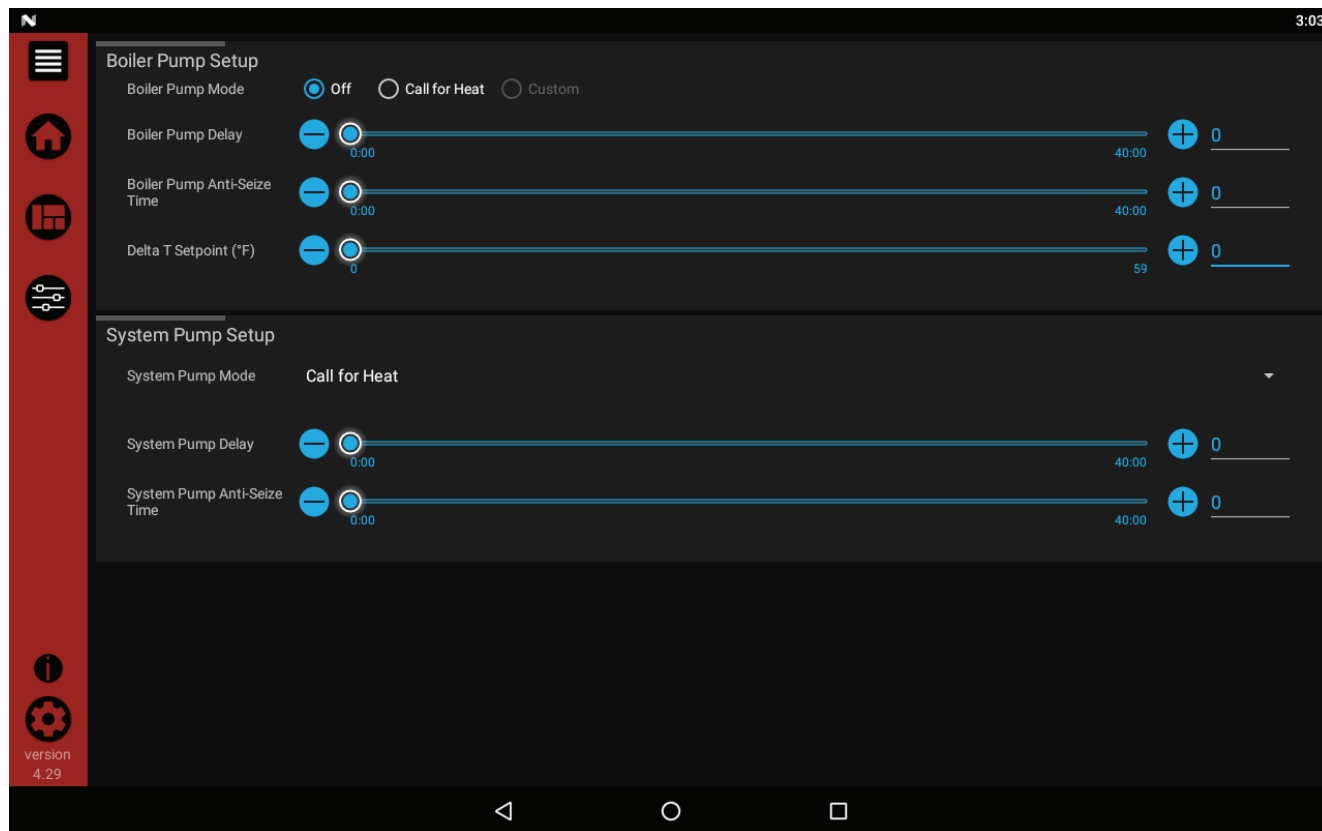

Table 1H Pumps (This table lists control module parameters; use the sub-tab under the Setup tab to access them.)

Menu	Parameter Name (as shown on the LCD screen)	Min	Max	Default
		Value	Value	Value
PUMPS	Boiler Pump Mode	N/A	N/A	N/A
	Boiler Pump Delay	0:00	40:00	0:30
	Boiler Pump Anti-Seize Time	0:00	40:00	0:33
	System Pump Mode	N/A	N/A	N/A
	System Pump Delay	0:00	40:00	0:30
	System Pump Anti-Seize Time	0	40:00	0:33
	Delta T Set point	0	60	0
DHW PUMP SETUP	DHW System Pump Mode	N/A	N/A	N/A
	DHW Pump Delay	0.5	2400	30
	DHW Pump Anti-Seize Time	0	40	0.33
HW SETUP	DHW Type	NORMAL	ZONE	NORMAL
	DHW/SH Switching Time	0	240	30
	SH/DHW Switching Time	0	240	30
	DHW Max Fan Speed	10	100	100

1 Service

Pumps

System Pump Mode

The SMART TOUCH control is able to control the system pump in 5 different ways. The options are as follows:

1. ON with a call for heat, with a constant speed.
2. ON with a call for heat, with a variable speed input.
3. Always ON, with a constant speed, except during outdoor shutdown.
4. Always ON, with a variable speed input, except during outdoor shutdown.
5. Always OFF (not connected).

For options 2 and 4, the speed of the system pump is controlled by a separate control system. The pump speed is sent to the 0-10V pump speed input on the boiler.

Boiler Pump Delay

The SH pump delay parameter sets the length of time the boiler pump will run after a SH demand has been satisfied.

Boiler Pump Anti-Seize Time

If the boiler pump does not run for 24 hours, it will be turned on briefly to prevent it from seizing. The length of time it runs is determined by the Boiler Pump Anti-Seize Time parameter.

Boiler Pump Mode

The SMART TOUCH control is able to control the boiler pump in 3 different ways. The options are as follows:

1. ON with a call for heat, with a constant speed.
2. ON with a call for heat, with a variable speed output.
3. Always OFF (not connected).

System Pump Delay

The system pump delay parameter sets the length of time the system pump (if connected) will run after a SH demand has been satisfied.

System Pump Anti-Seize Time

If the boiler pump does not run for 24 hours, it will be turned on briefly to prevent it from seizing.

ΔT Set Point

The SMART TOUCH control includes a 0 - 10Vdc output for controlling the speed of a variable speed boiler pump. This feature can be used with primary - secondary piping systems only. The speed is regulated in order to, among other things, maintain a minimum delta T across the heat exchanger. This helps reduce the electrical consumption of the boiler pump when the boiler is firing at less than its maximum rate. (This feature is active only when a system supply sensor is installed).

DHW System Pump Mode

This parameter allows the installer to determine how the system pump responds to a DHW call for heat. The parameter can be adjusted through the DHW System Pump Mode parameter. Select **Always Off** if you want the system pump to always turn off during a DHW call for heat. Select **Always On** if you want the system pump to always turn on during a DHW call for heat. Select **Normal** if you want the system pump to ignore the DHW call for heat and operate based on the System Pump Mode setting only.

DHW Pump Delay

The DHW pump delay parameter sets the length of time the DHW pump (if connected) will run after a DHW demand has been satisfied. This parameter is adjustable by the installer by accessing the DHW Pump Delay parameter.

DHW Pump Anti-Seize Time

If the boiler pump does not run for 24 hours, it will be turned on briefly to prevent it from seizing. The length of time it runs is determined by the DHW Pump Anti-Seize Time.

DHW Type

This parameter gives the installer a choice of piping directly to the boiler for use as a hot water generator for domestic hot water (DHW), or as a zone in the heating system. This parameter can be adjusted through the DHW Type parameter. For direct DHW select **Normal**, for treating the DHW as a zone, select **Zone**.

DHW/SH Switching Time

When a boiler has a DHW demand and it receives a space heating demand, the SMART TOUCH control will start a timer. Once the timer expires, it will stop the DHW demand and service the space heating demand. This feature does not apply when the DHW is programmed as a zone, or in Cascade. The installer can adjust the length of time the boiler will service the DHW demand by accessing the DHW/SH Switching Time parameter.

SH/DHW Switching Time

When a boiler has a space heating demand and it receives a DHW demand, it will immediately switch to the DHW demand and start a timer. Once the timer has expired, the boiler will switch back to the space heating demand and start another timer. Once this timer expires, it will switch back to the DHW demand. This feature does not apply when the DHW is programmed as a zone, or in Cascade. The installer can adjust the length of time the boiler will service the space heating demand by accessing the SH/DHW Switching Time parameter.

DHW Rate Limiting

This parameter determines the maximum rate to be used when heating a DHW tank. This setting may be used when the tank is unable to accept all of the BTU's available from the boiler. This parameter may be adjusted by the installer by accessing the DHW Rate Limiting parameter.

1 Service *(continued)*

Cascade Screens

Figure 1-13 Cascade Setup

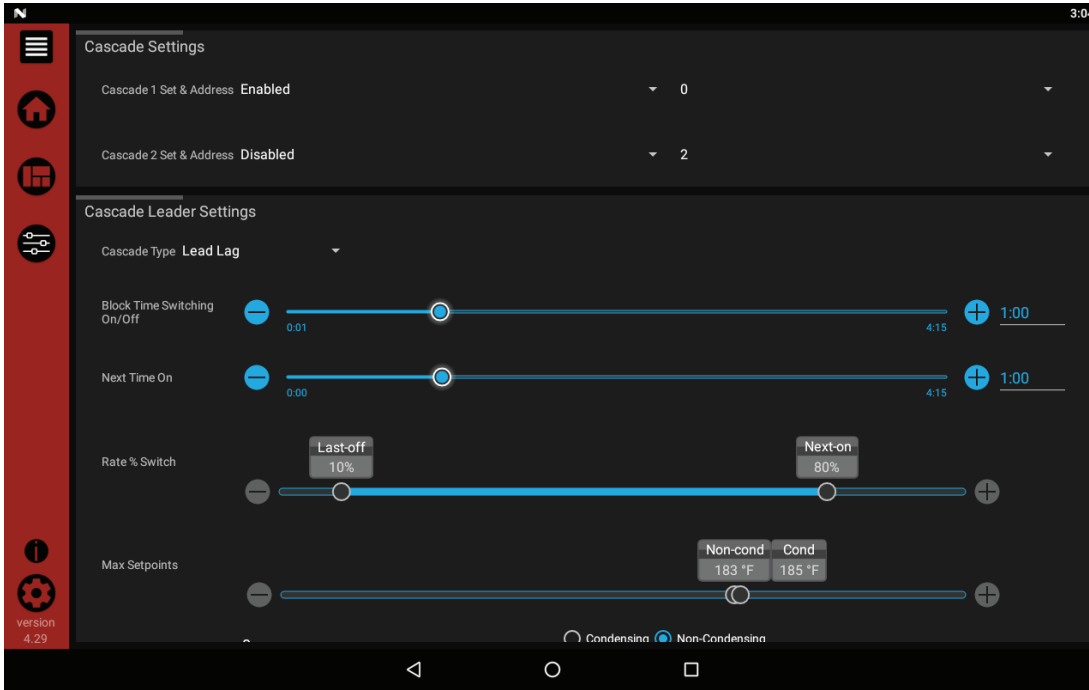
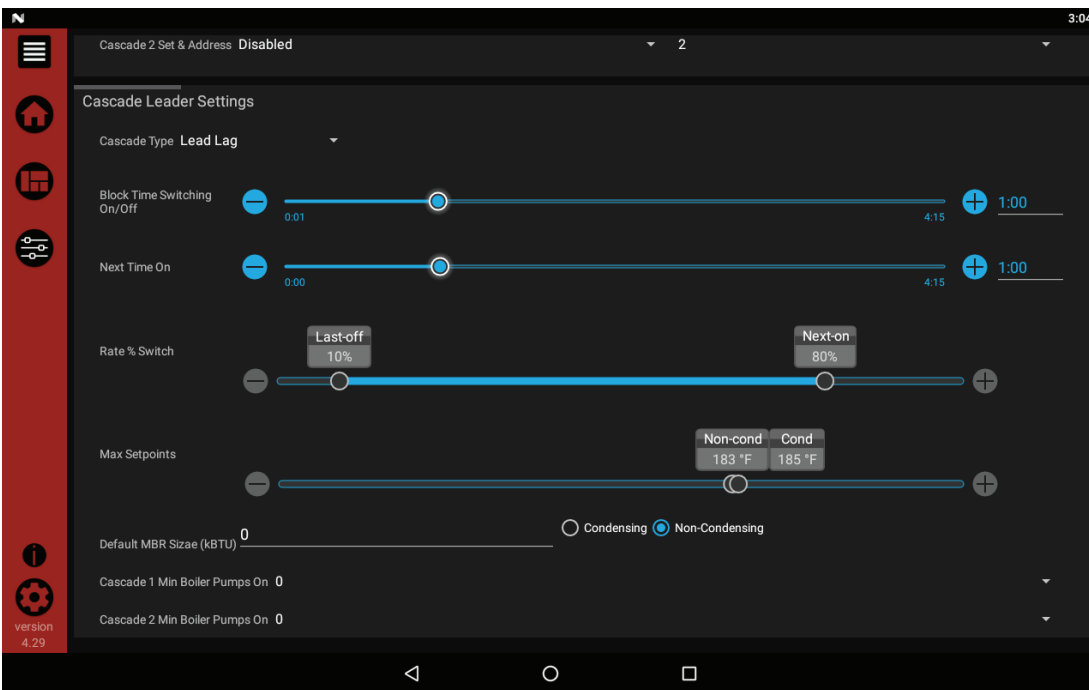

Figure 1-14 Cascade Leader Setup



1 Service

Table 11 Cascade (This table lists control module parameters; use the sub-tab under the Setup tab to access them.)

Menu	Parameter Name (as shown on the LCD screen)	Min	Max	Default
		Value	Value	Value
CASCADE	Cascade Address	0	7	1
	Cascade Status	ENABLE	DISABLE	DISABLE
	Cascade Type	N/A	N/A	N/A
	Cascade Set point: Offset	0	40	10
	Cascade Set point: Differential	0	72	20
	Max Cascade Cond. Set point (F)	32	185	185
	Max Cascade Non-Cond Set point (F)	68	260	185
	Block Time Switching Boiler On / Off	0	4:15	60
	Minimum Next On Time	0	4:15	60
	Rate % to Switch On Next Boiler	1	100	80
	Rate % to Switch Off Last Boiler	1	100	10
	Member Size Code*	0	255	0
	Redundant Leader	Disable	Enable	Disable

Cascade

Cascade Address

The boiler designated as the Leader needs to be programmed with address 0. All the Member boilers require addresses from 1 to 7, and the addresses must be different for each Member. The addresses can be in any order, regardless of the order in which the units are wired together. The outdoor air (if used) and system supply sensor must be connected to the Leader boiler.

Cascade Status

The boiler is part of a group of units sequenced together. The designated Leader unit determines the total output needed from the group based on the set point and controlling sensor reading. It assigns portions of the output to itself (Leader) and the Member units. When Cascade is active, each boiler in the group requires a unique address.

Cascade Type

The two (2) types of Cascade control are listed below:

Efficiency Optimization

This method is used when it is desired to have the most efficient system. When the first boiler reaches a certain rate (default = 80%), it lowers its rate to 40% and turns on the next boiler at 40%. The two (2) boilers then modulate at the same rate. As the calculated load increases further and both boilers ramp up to 80%, it lowers the rate of the first two (2) boilers to 53% and brings the next boiler on at 53%. The three (3) boilers then modulate together. As the calculated load decreases, the boilers will reach a lower threshold (default = 10%), at which time the last boiler (the third one in this example) will turn off and the Cascade will increase the rates of the remaining boilers to provide the equivalent total output as before $((3 \times 10\%) / 2 = 15\%$ in this example).

L/L: Lead/Lag

This method is used when it is desired to run the least number of boilers as possible. When the first boiler reaches 100% and calculated demand is still greater, the Cascade will bring on boiler number two. At the same time the first boiler will reduce its firing rate by an amount equal to the initial firing rate of the second boiler. As the calculated demand continues to increase, the first boiler will go to high fire, followed by ramping up the second boiler. If the calculated demand is still increasing once the second boiler reaches 100%, the Cascade will bring on boiler number three and reduce the firing rate of boiler number two by an amount equal to the initial firing rate of the third boiler.

This sequence will continue until the load is matched or all boilers are firing at 100%. When the load begins to decrease, the last boiler to fire will modulate down to low fire and hold there. As the calculated demand continues to decrease, the second to the last boiler will modulate down to low fire. If calculated demand is still decreasing, the last boiler will shut down and the next to the last boiler will increase its firing rate to make up the lost BTU's of the last boiler. If the calculated demand continues to decrease, it will modulate down to low fire and hold there while the next previous boiler starts to modulate down, as before. This will continue until either demand is matched or all boilers have shut down.

Cascade Set point Offset

This parameter determines how much the temperature can go above set point before the lead boiler will turn off.

Cascade Set point Differential

This parameter determines how much the temperature must go below the turn off temperature (Set point + Offset) before the lead boiler turns on.

1 Service *(continued)*

Maximum Cascade Cond and Non-Cond Set point (F)

These types of parameters determine the set point used by the individual boilers in a Cascade. When a boiler is commanded to fire by the Leader boiler, it will attempt to achieve this temperature at its outlet. If any of the boiler outlet temperatures reach the maximum cascade set point, the boiler will then modulate down on its own in order to keep its outlet temperature within the maximum cascade set point. Therefore, these parameters can be used to limit the outlet temperatures of all the boilers in a Cascade. Note that these parameters do not apply when the boiler is heating an indirect DHW tank.

Blocking Time Switching Boiler On / Off

In order to prevent units in a Cascade from short cycling, this parameter defines the minimum ON and OFF time for each unit. The installer can adjust this time by accessing the Blocking Time Switching Boiler On / Off parameter.

Minimum Next On Time

In order to reduce the risk of temperature overshoot with a Cascade, this parameter defines the minimum time delay from starting one unit until the next unit may be started.

Number of Boiler Pumps Always On

When multiple Crest boilers are connected in a Cascade, the SMART TOUCH control can keep a minimum number of the boiler pumps running, regardless of how many of the boilers are firing. This is useful in full flow systems where the system flow is provided by the individual boiler pumps.

Rate % to Switch on Next Boiler

When the Cascade is programmed in the Efficiency Optimization Mode, the currently running boilers must ramp up to a certain firing rate before the next boiler in the Cascade will start.

Rate % to Switch off Last Boiler

When the Cascade is programmed in the Efficiency Optimization Mode, the currently running boiler will stop at this rate.

Member Size Code

The member size code parameter is used to determine the maximum power and priority of legacy boilers (i.e., Power-fin) in cascade with the Crest Boiler. The default value for this parameter is 0. When this value is left unchanged, the SMART TOUCH control will automatically assume that any member(s) of the Cascade not communicating their size will be 1,500,000 Btu. The lowest priority will always be given to these units because the SMART TOUCH control will assume they are non-condensing boilers. Changing this parameter is not necessary for Cascade operation. However, the installer can adjust this code by using the PC program. The PC program will calculate the proper code based on the information provided.

Redundant Leader

This parameter allows the Member 1 boiler to automatically assume control of the Cascade should it lose communication with the Leader boiler. When programmed to YES, it is recommended that the Member 1 boiler have its own set of external sensors installed (such as the system supply sensor), to maintain the same level of temperature control as with the Leader boiler. Voltage signals (such as the 0 - 10V system pump speed input) can be connected to both boilers. DO NOT connect the sensors connected to the Leader boiler to the Member 1 boiler. The actual water temperatures will be higher than expected, which could lead to property damage, personal injury, or death. When communication is re-established with the Leader boiler, Member 1 will automatically relinquish control of the Cascade to the Leader boiler. The default value of this parameter is NO.

Figure 1-15A Cascade Redundant Leader Selected

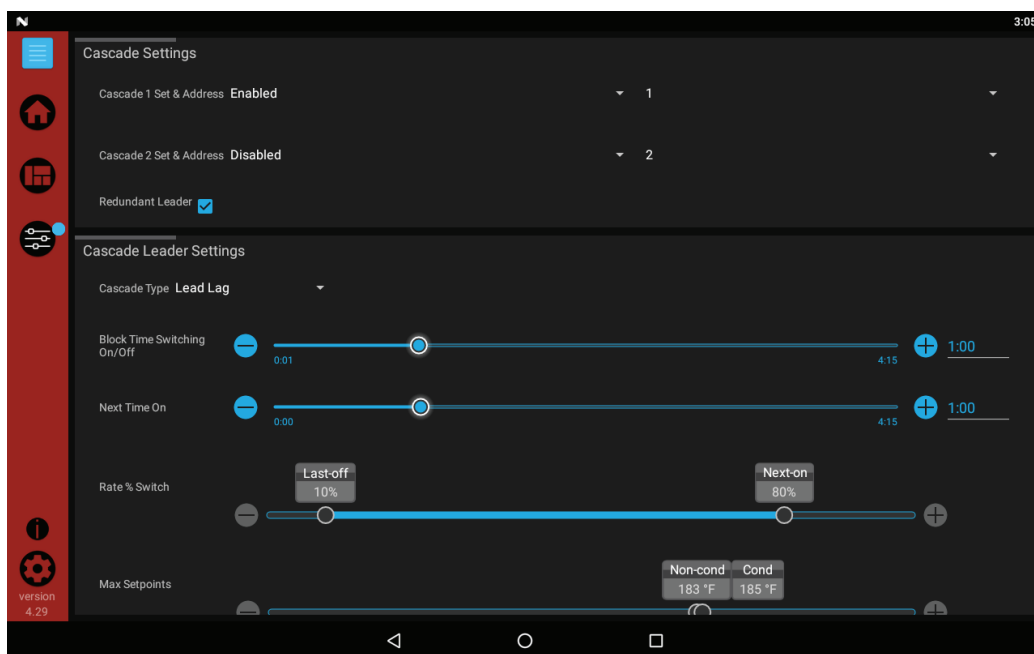

1 Service

Service Screens

Figure 1-15B Cascade Redundant Leader Selected

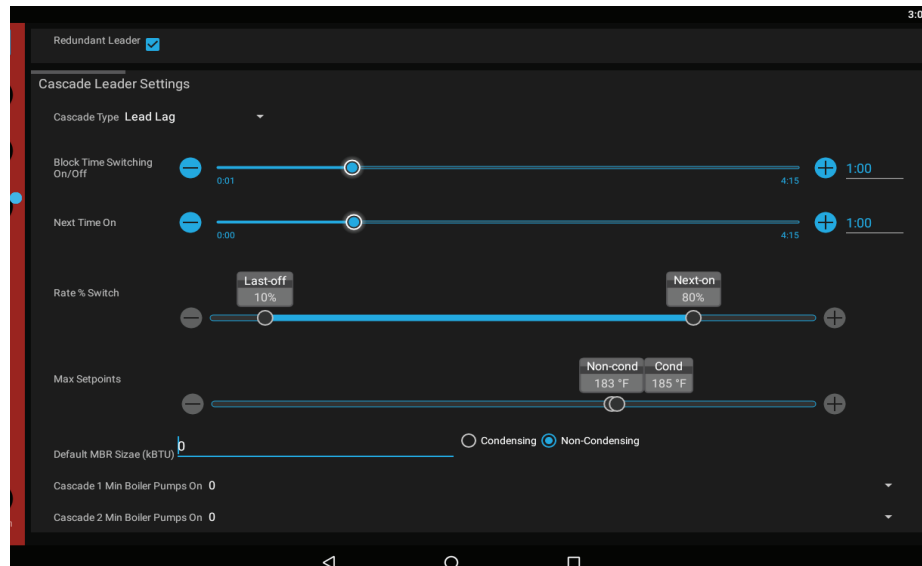
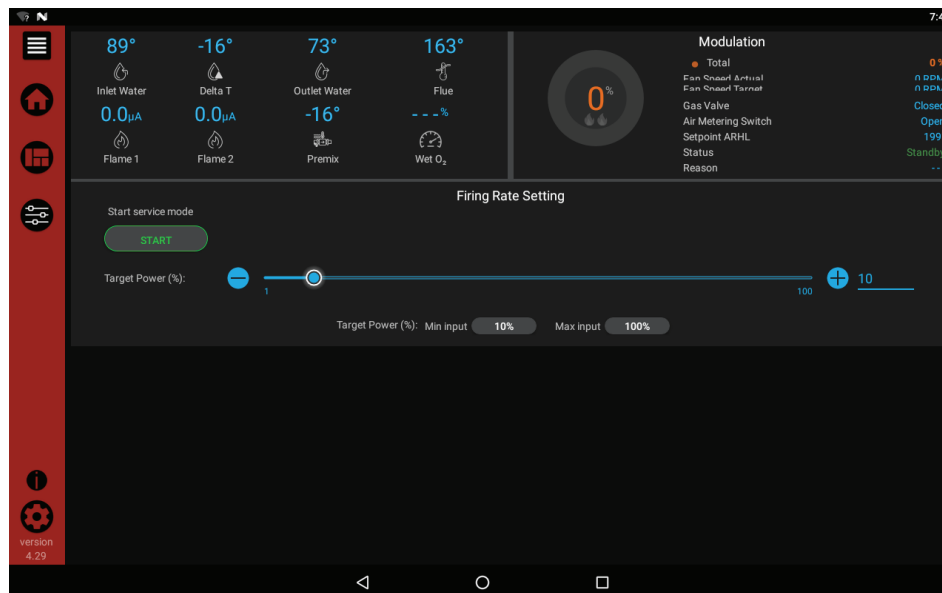

Figure 1-16 Service Maintenance



The Service Screen allows the integrated control to override all other heat demands and operates the combustion system manually through the complete modulation range. To place the boiler into Service Mode, press the START button. As specified above the integrated control will override all other heat demands, however, all safeties will be active. If no buttons are pressed, the integrated control will automatically revert back to its original status after the “Remaining time in Service” counter expires.

Once the boiler has been placed into Service Mode it will light and modulate to low fire. At any time after that point use the touch screen to adjust the firing rate. The first way is by pressing one of the six (6) preset buttons. The second way is by manually adjusting the firing percentage using the “+” and “-” buttons. When Service Mode is no longer needed press the STOP button to return to normal operation.

1 Service *(continued)*

Graph Screens

The Graph Screen consists of two (2) different types of screens. The first screen Short Term Data Screen (three minutes in one second intervals) and the Long Term Data Screen (32 days, 233 average minutes). If a parameter is selected by mistake, it can be de-selected by re-selecting the parameter. A maximum of eight (8) items can be graphed at one time.

Figure 1-17 Graph Select

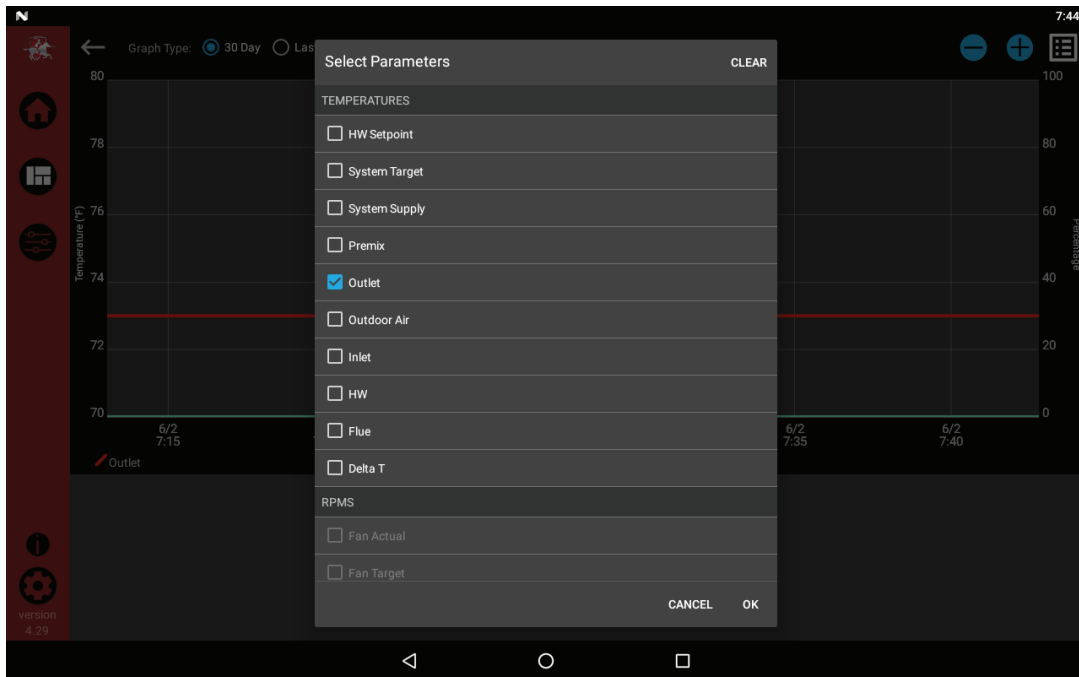

Once the items to be graphed are selected, press the OK button to view the graph. Each item graphed will have a different color line to represent it. The items selected will be shown below the graph along with their corresponding color.

Figure 1-18 Graph Screen

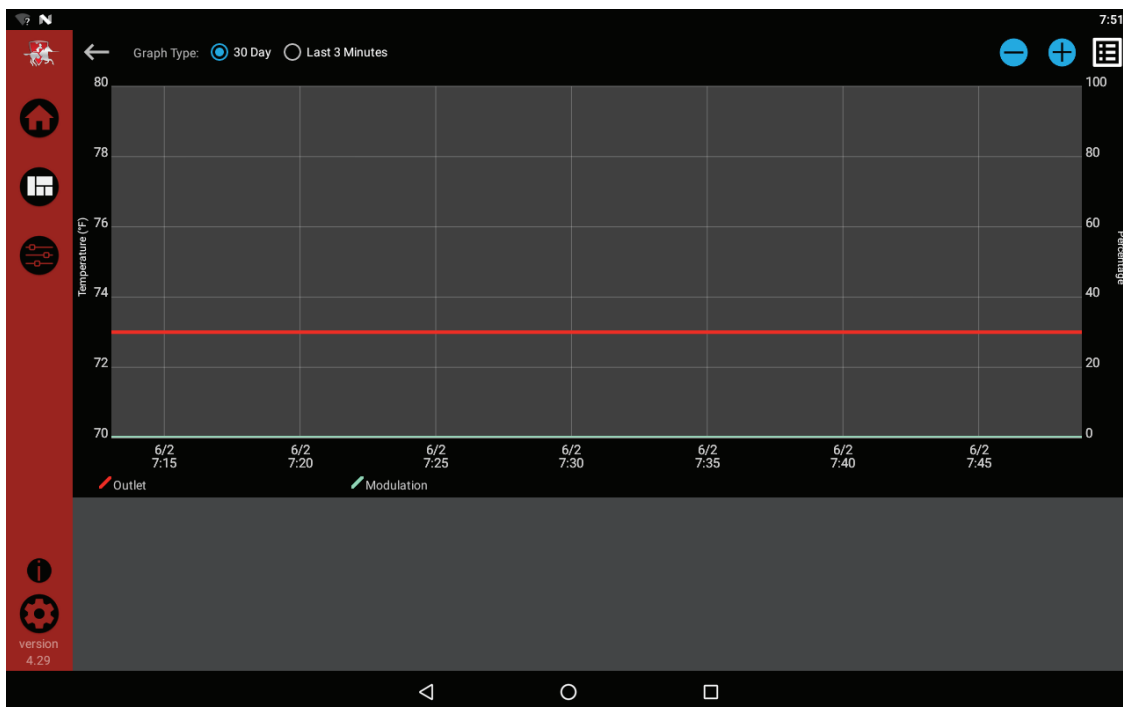

1 Service

History Screen

The History Screen shows the status of various counters and faults. Within the History Screen there are two separate sections, the “Lockout Blocking Fault” and “Runtime History”.

The left side of the screen reflects the “Lockout Blocking Fault” section which allows you to view the last 20 lockout/blocking faults. Succeeded by each fault is the date and time of when the fault occurred. A three (3) minute graph of sensor data before the fault can be viewed by selecting the VIEW button.

The “Runtime History” section includes the following information:

- Power hours – Shows the number of hours the control has been powered on since the last reset.
- Running hours – Shows the number of hours that the boiler has been firing since the last reset.
- Ignition attempts – Shows the number of times the control has attempted to ignite since the last reset.
- Successful Ignition attempts - Shows the number of times the control has successfully ignited since the last reset.
- Total Power hours – Show the total number of hours the control has been powered.
- Total Running hours – Show the total number of hours that the boiler has been firing.
- Total ignition attempts – Show the total number of times the control has attempted to ignite.
- Total Successful ignition attempts – Show the total number of times the control has successfully ignited.

The top right of this screen details the running hours based on 4 different running positions.

Figure 1-19 History Screen / Runtime History

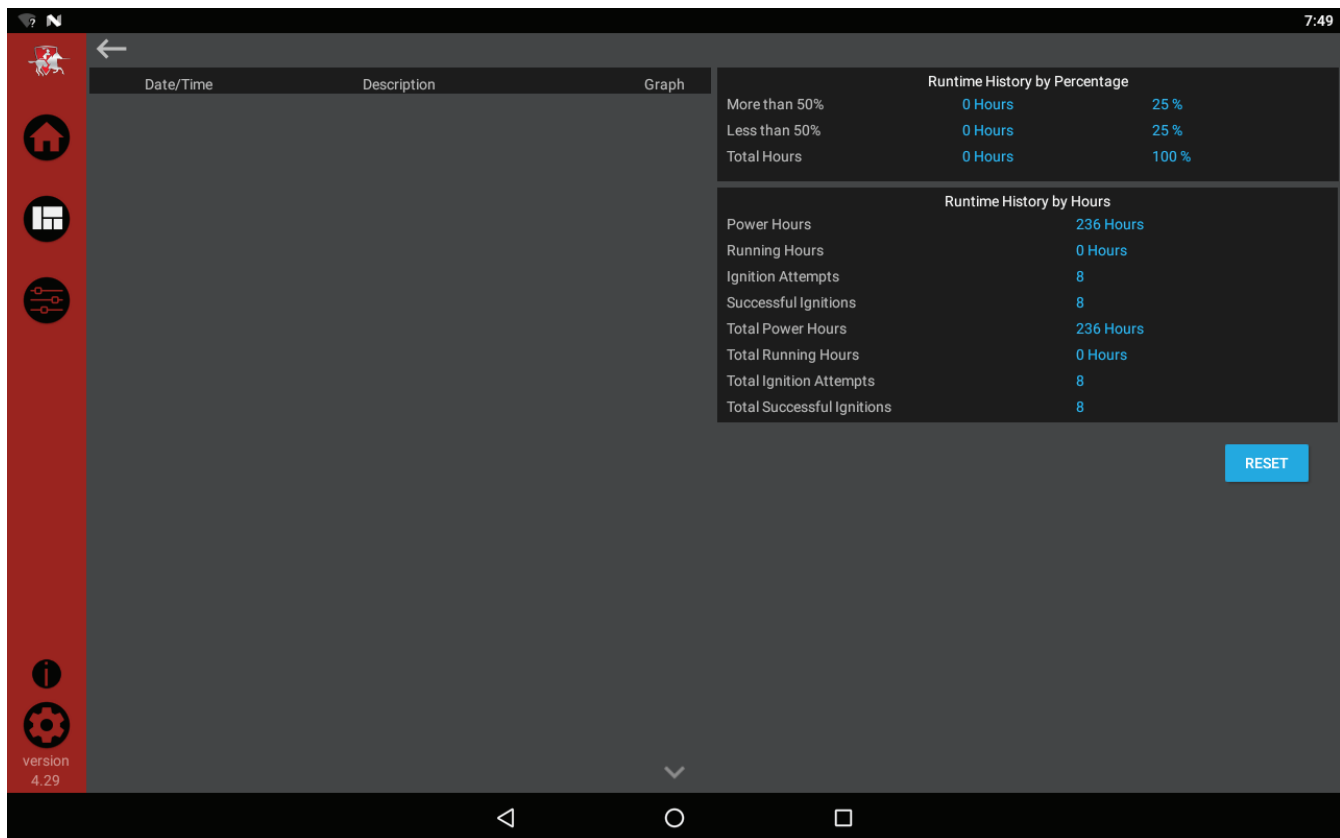

2 Maintenance

Maintenance and annual startup

Table 2A Service and Maintenance Schedules

Service technician (see the following pages for instructions)		Owner maintenance (see the Crest User's Information Manual for instructions)	
ANNUAL START-UP	General:	Daily	<ul style="list-style-type: none"> • Check boiler area • Check pressure/temperature gauge
	<ul style="list-style-type: none"> • Address reported problems, if any • Inspect interior; clean and vacuum if necessary; • Clean condensate trap and fill with fresh water • Check for leaks (water, gas, flue, condensate) • Verify flue and air lines in good condition and sealed tight • Check system water pressure/system piping/expansion tank • Check fill water meter • Test boiler water. When test indicates, clean system water with approved system restorer following manufacturer's information. • Check control settings • Check the ignition and both flame sense electrodes (sand off any deposits; clean and reposition) • Check wiring and connections • Perform start-up checkout and performance verification per Section 9. • Flame inspection (stable, uniform) • Check both flame signals (at least 10 microamps at high fire) • Clean the heat exchanger • Test low water cutoff. 	Monthly	<ul style="list-style-type: none"> • Check vent piping • Check air piping • Check air and vent termination screens • Check relief valve • Check condensate drain system • Check and replace filter as needed
	<p>If combustion or performance indicate need:</p> <ul style="list-style-type: none"> • Clean heat exchanger • Remove and clean burner using compressed air and vacuum cleaner • Clean the blower wheels 	Every 6 months	<ul style="list-style-type: none"> • Test low water cutoff • Reset button (low water cutoff) • Check boiler piping (gas and water) for leaks • Operate relief valve • Check boiler screen for O2 sensor error messages
		End of season months	<ul style="list-style-type: none"> • Shut boiler down (unless boiler used for domestic hot water)

2 Maintenance

⚠ WARNING Follow the service and maintenance procedures given throughout this manual and in component literature shipped with the boiler. Failure to perform the service and maintenance could result in damage to the boiler or system. Failure to follow the directions in this manual and component literature could result in severe personal injury, death, or substantial property damage.

⚠ WARNING The boiler should be inspected annually only by a qualified service technician. In addition, the maintenance and care of the boiler designated in Table 2A and explained on the following pages must be performed to assure maximum boiler efficiency and reliability. Failure to service and maintain the boiler and system could result in equipment failure.

⚠ WARNING Electrical shock hazard – Turn off power to the boiler before any service operation on the boiler except as noted otherwise in this instruction manual. Failure to turn off electrical power could result in electrical shock, causing severe personal injury or death.

Address reported problems

1. Inspect any problems reported by the owner and correct before proceeding.

Inspect boiler area

1. Verify that boiler area is free of any combustible materials, gasoline and other flammable vapors and liquids.
2. Verify that air intake area is free of any of the contaminants listed in Section 1 of this manual. If any of these are present in the boiler intake air vicinity, they must be removed. If they cannot be removed, reinstall the air and vent lines per this manual.

Inspect boiler interior

1. Remove the front access covers and inspect the interior of the boiler.
2. Vacuum any sediment from inside the boiler and components. Remove any obstructions.

Clean condensate trap

1. Inspect the condensate drain line, vent line, condensate PVC fittings, and condensate trap.

Flush condensate trap with water

1. Remove the four (4) screws securing the top cover to the condensate trap and remove the cover (FIG. 2-1).
2. Locate the plastic ball inside the float tube. Verify there is nothing under the ball causing it to not seat properly.
3. Fill with fresh water until the water begins to pour out of the drain.
4. Replace the top cover and the screws removed in Step 1.

Figure 2-1 Condensate Trap

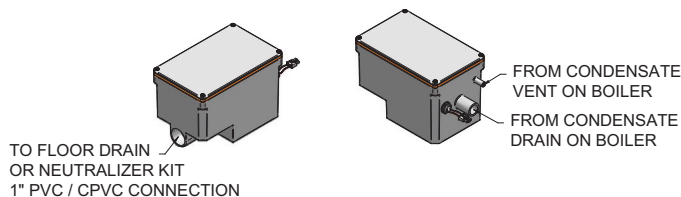

Check all piping for leaks

⚠ WARNING Eliminate all system or boiler leaks. Continual fresh makeup water will reduce boiler life. Minerals can build up, reducing heat transfer, overheating heat exchanger, and causing heat exchanger failure. Leaking water may also cause severe property damage.

1. Inspect all water and gas piping and verify to be leak free.
2. Look for signs of leaking lines and correct any problems found.
3. Check gas line using the procedure found in Section 6 - *Gas Connections of the Crest Installation and Operation Manual*.

Flue vent system and air piping

1. Visually inspect the entire flue gas venting system and air piping for blockage, deterioration or leakage. Repair any joints that show signs of leakage. Verify that air inlet pipe is connected and properly sealed.
2. Verify that boiler vent discharge and air intake are clean and free of obstructions.

⚠ WARNING Failure to inspect for the above conditions and have them repaired can result in severe personal injury or death.

Check water system

1. Verify all system components are correctly installed and operational.
2. Check the cold fill pressure for the system. Verify it is correct (must be a minimum of 12 psi (82.7 kPa)).
3. Watch the system pressure as the boiler heats up (during testing) to ensure pressure does not rise too high. Excessive pressure rise indicates expansion tank sizing or performance problem.
4. Inspect automatic air vents and air separators. Remove air vent caps and briefly press push valve to flush vent. Replace caps. Make sure vents do not leak. Replace any leaking vents.

2 Maintenance *(continued)*

Check expansion tank

1. Expansion tanks provide space for water to move in and out as the heating system water expands due to temperature increase or contracts as the water cools. Tanks may be open, closed or diaphragm or bladder type. See Section 5 - *Hydronic Piping* of the Crest Installation and Operation Manual for suggested best location of expansion tanks and air eliminators.

Check fill water meter

1. Check fill water meter for water usage. If the amount exceeds 5% of your system volume, you could have a leak. Have the system checked for leaks and fixed by a qualified service technician.

Test boiler water

1. Test boiler water. Reference the Crest Installation and Operation Manual for guidelines. When test indicates, clean system water with approved system restorer following the manufacturer's information.

Check boiler relief valve

1. Inspect the relief valve and lift the lever to verify flow. Before operating any relief valve, ensure that it is piped with its discharge in a safe area to avoid severe scald potential. Read Section 5 - *Hydronic Piping* of the Crest Installation and Operation Manual before proceeding further.

⚠ WARNING Safety relief valves should be re-inspected AT LEAST ONCE EVERY THREE YEARS, by a licensed plumbing contractor or authorized inspection agency, to ensure that the product has not been affected by corrosive water conditions and to ensure that the valve and discharge line have not been altered or tampered with illegally. Certain naturally occurring conditions may corrode the valve or its components over time, rendering the valve inoperative. Such conditions are not detectable unless the valve and its components are physically removed and inspected. This inspection must only be conducted by a plumbing contractor or authorized inspection agency – not by the owner. Failure to re-inspect the boiler relief valve as directed could result in unsafe pressure buildup, which can result in severe personal injury, death, or substantial property damage.

⚠ WARNING Following installation, the valve lever must be operated AT LEAST ONCE A YEAR to ensure that waterways are clear. Certain naturally occurring mineral deposits may adhere to the valve, rendering it inoperative. When manually operating the lever, water will discharge and precautions must be taken to avoid contact with hot water and to avoid water damage. Before operating lever, check to see that a discharge line is connected to this valve directing the flow of hot water from the valve to a proper place of disposal. Otherwise severe personal injury may result. If no water flows, valve is inoperative. Shut down the boiler until a new relief valve has been installed.

2. After following the above warning directions, if the relief valve weeps or will not seat properly, replace the relief valve. Ensure that the reason for relief valve weeping is the valve and not over-pressurization of the system due to expansion tank waterlogging or undersizing.

Inspect ignition and flame sense electrodes

1. Remove the ignition and both flame sense electrodes from the burner plate.
2. Remove any deposits accumulated on the ignition/flame sense electrodes using sandpaper. If the electrodes cannot be cleaned satisfactorily, replace with new ones.
3. Replace ignition/flame sense electrodes, making sure the gaskets are in good condition and correctly positioned.

Check ignition ground wiring

1. Inspect boiler ground wire from the heat exchanger access cover to ground terminal strip.
2. Verify all wiring is in good condition and securely attached.
3. Check ground continuity of wiring using continuity meter.
4. Replace ground wires if ground continuity is not satisfactory.

Check all boiler wiring

1. Inspect all boiler wiring, making sure wires are in good condition and securely attached.

Check control settings

1. Navigate to the Setup Screen and check all settings. See Section 1 of this manual. Adjust settings if necessary. See Section 1 of this manual for adjustment procedures.
2. Check settings of external limit controls (if any) and adjust if necessary.

Perform start-up and checks

1. Start boiler and perform checks and tests specified in Section 9 - *Start-up of the Crest Installation and Operation Manual*.
2. Verify cold fill pressure is correct and that operating pressure does not go too high.

Check burner flame

1. Inspect flame through observation windows.
2. If the flame is unsatisfactory at either high fire or low fire, remove and clean the burner. Clean the burner thoroughly using a vacuum cleaner or compressed air. Do not use compressed air to clean the burner if cleaning is performed inside a building.
 - Shut down the boiler:
 - Follow the "To Turn Off Gas to Appliance" instructions for the boiler in Section 9 - Startup of the Crest Installation and Operation Manual.
 - Do not drain the boiler unless it will be exposed to freezing temperatures. If using freeze prevention fluid in system, do not drain.
3. Allow time for the boiler to cool to room temperature if it has been firing.

2 Maintenance

4. Remove the top access panel(s) to gain access to the gas/air manifold assembly.
5. Remove the gas/air manifold burner access cover (FIG. 2-2).
6. Remove the nuts/washers holding the burner to the gas/air manifold assembly.
7. Remove the burner from the gas/air manifold assembly. There is no need to remove the manifold from the top plate for the burner removal. The manifold is designed to gain access by removing the manifold cover.

NOTICE

The burner gasket, burner, burner baffle, and gas/air manifold access cover can only be installed in one orientation. All of these parts will have to be re-installed correctly. To ensure all of these parts are re-installed correctly, align the logo on top of the gas/air manifold cover with the logo on the gas/air manifold as shown in FIG. 2-2. Be certain to pay close attention to the bolt pattern when re-installing the above parts.

8. When replacing the burner, ensure gaskets are in good condition and positioned correctly (FIG. 2-2).
9. Re-install burner assembly parts in the reverse order of disassembly.
10. When securing the burner and/or manifold, be sure to tighten the nuts as follows:
 - a. Tighten the nuts in a star pattern.
 - b. Tighten all nuts to the specified torques in FIG. 2-3.
11. After firing the unit, re-tighten the nuts to the torque specifications.
12. After final tightening of the nuts with the blower at high rpms, check for leaks around the burner assembly.

WARNING

Failure to follow the torquing specifications listed above could result in severe personal injury or death.

Figure 2-2 Burner Assembly

NOTE: Be sure to pay close attention to the Lochinvar logo. Align the logo with the Lochinvar logo on the gas/air manifold to ensure proper assembly. Pay close attention to the bolt pattern, as the gas/air manifold assembly can only be installed one way.

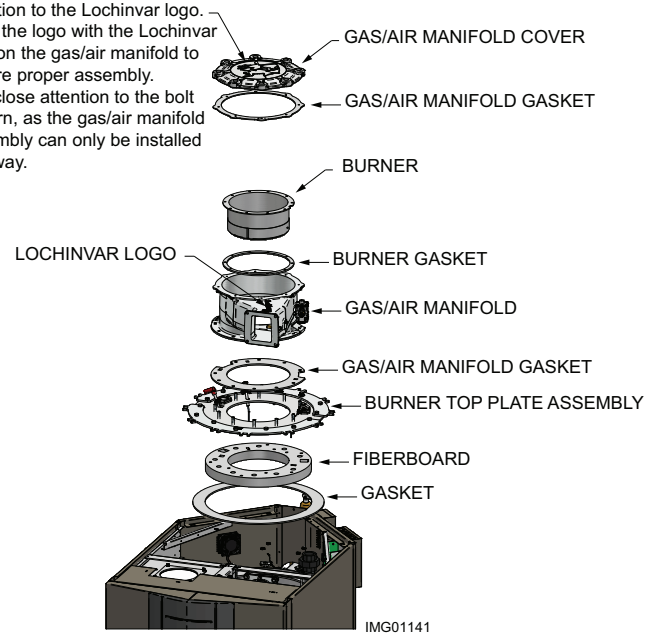
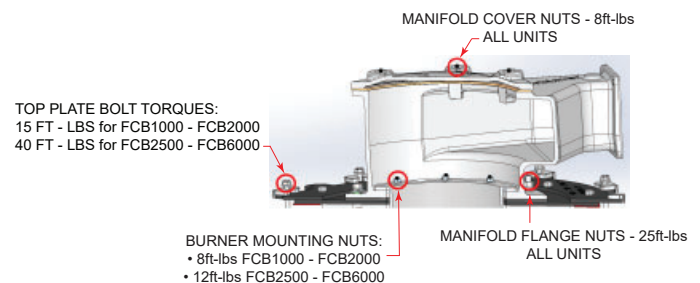

Figure 2-3 Burner Assembly Torque Values



Check flame signal

1. At high fire of each combustion system, the flame signal shown on the display should be at least 10 microamps.
2. A lower flame signal may indicate a fouled or damaged flame sense electrode. If cleaning the flame sense electrodes does not improve, ground wiring is in good condition, and ground continuity is satisfactory, replace the flame sense electrode.
3. See Section 3 - *Troubleshooting* in this manual for other procedures to deal with low flame signal.

Check O2 sensor

1. A self-diagnosis feature is programmed into the O2 sensor control. If there is a problem with the O2 sensor, the appropriate error will be displayed. The unit will continue to operate on the last known combustion curve. Contact a qualified service technician to inspect and replace the O2 sensor as needed.

2 Maintenance *(continued)*

Review with owner

1. Review the Crest User's Information Manual with the owner.
2. Emphasize the need to perform the maintenance schedule specified in the Crest User's Information Manual (and in this manual as well).
3. Remind the owner of the need to call a licensed contractor should the boiler or system exhibit any unusual behavior.
4. Remind the owner to follow the proper shutdown procedure and to schedule an annual start-up at the beginning of the next heating season.

Cleaning boiler heat exchanger

1. Shut down boiler:
 - Follow the "To Turn Off Gas to Appliance" instructions for the boiler in Section 9 - Startup.
 - Do not drain the boiler unless it will be exposed to freezing temperatures. If using freeze prevention fluid in system, do not drain.
2. Allow time for the boiler to cool to room temperature if it has been firing.
3. Remove the top access panel to gain access to the burner top plate assembly.
4. Access to the heat exchanger can be gained by removing the burner through the manifold cover or by removing the entire top plate assembly (reference FIG. 2-3 on page 38 of this manual).

NOTICE

It is recommended that care should be taken to avoid getting the fiber board wet in the cleaning process.

WARNING

The boiler contains ceramic fiber materials. Use care when handling these materials per instructions on this page. Failure to comply could result in severe personal injury.

5. Remove the necessary components to gain the needed access for heat exchanger cleaning, see FIG. 2-2.
6. Use a vacuum cleaner to remove any accumulation on the tube sheet surfaces. Do not use any solvent.
7. Brush the heat exchanger (tube sheet, combustion chamber walls, and tube entry) while dry using a nylon bristle brush. **Caution:** DO NOT use a metal brush. Re-vacuum the heat exchanger.
8. Finish cleaning using a clean cloth dampened with warm water.

9. Temporarily remove the condensate drain line from the condensate trap and route directly to a drain.
10. Rinse out debris with a low pressure water supply. The water will drain through the condensate connection.
11. Allow the heat exchanger to thoroughly dry.
12. Reconnect the condensate drain line to the condensate trap.
13. Close isolation valves on piping to isolate boiler from system. Attach a hose to the boiler drain and flush boiler thoroughly with clean water by using purging valves to allow water to flow through the water make-up line to the boiler.
14. Re-assemble all parts in the reverse order of disassembly ensuring all gaskets are in good condition and that all torque specifications are followed as depicted in FIG. 2-3.

Note: All seals should be leak checked and re-torqued after the unit heats up and cools down.
15. After firing the unit, re-tighten the nuts to the torque specifications in FIG. 2-3 on page 38. After the final tightening of the nuts with the blower at high RPMs, check for leaks around the burner assembly.
16. Restore boiler to operation.
17. Perform start-up and check-out procedures in the Check Flame and Combustion - Section 9 - Startup of the Crest Installation and Operation Manual.

2 Maintenance

Handling ceramic fiber materials REMOVAL OF COMBUSTION CHAMBER LINING

WARNING

The combustion chamber insulation in this appliance contains ceramic fiber material. Ceramic fibers can be converted to cristobalite in very high temperature applications. The International Agency for Research on Cancer (IARC) has concluded, "Crystalline silica in the form of quartz or cristobalite from occupational sources is carcinogenic to humans (Group 1)."

Normal operating temperatures in this appliance are below the level to convert ceramic fibers to cristobalite. Abnormal operating conditions would have to be created to convert the ceramic fibers in this appliance to cristobalite.

The ceramic fiber material used in this appliance is an irritant; when handling or replacing the ceramic materials it is advisable that the installer follow these safety guidelines.

- Avoid breathing dust and contact with skin and eyes.
 - Use NIOSH certified dust respirator (N95). This type of respirator is based on the OSHA requirements for cristobalite at the time this document was written. Other types of respirators may be needed depending on the job site conditions. Current NIOSH recommendations can be found on the NIOSH website at <http://www.cdc.gov/niosh/homepage.html>. NIOSH approved respirators, manufacturers, and phone numbers are also listed on this website.
 - Wear long-sleeved, loose fitting clothing, gloves, and eye protection.
- Apply enough water to the combustion chamber lining to prevent airborne dust.
- Remove the combustion chamber lining from the boiler and place it in a plastic bag for disposal.
- Wash potentially contaminated clothes separately from other clothing. Rinse clothes washer thoroughly.

NIOSH stated First Aid.

- Eye: Irrigate immediately.
- Breathing: Fresh air.

Test low water flow conditions

NOTICE

This test is to be carried out once the Crest boiler is completely piped in with adequate gas and water flow. Once the test is completed, ensure that the isolation valve is opened up to allow full water flow.

Test procedure

1. Place the unit into Service Mode. Navigate to the Setup Screen from the Home Screen by pressing the SETUP button along the left side of the screen. Enter the installer password.
2. Select the Service Maintenance Screen. The tabs will scroll (up and down) to reveal more options.

On the Service Maintenance Screen place heater into Service Mode by selecting the START button. In Service Mode the boiler will fire at ignition speed and will then modulate up to full fire.
3. Allow the unit to progress through its normal diagnostics and pre-purge programming.
4. Allow the unit to fire and operate until the temperatures stabilize. This occurs when the inlet and outlet temperatures are rising together and the Delta T (ΔT) is maintained.
5. When the unit stabilizes, begin to slowly shut off the isolation valve on the outlet piping of the boiler (see FIG. 2-4). This will begin to restrict the flow and simulate a low flow condition.
6. While slowly shutting off the isolation valve, refer to the Status Screen to watch the behavior of the boiler. This screen allows you to monitor the inlet temperature, outlet temperature, and ΔT .
7. When the ΔT reaches 70°F, the control will attempt to modulate the firing rate down to protect it from low flow conditions.
8. When the ΔT reaches 80°F, the control module will turn off the burner. If the control module shuts down, the test was successful.
9. Completely open the isolation valve on the outlet piping of the boiler.
10. Resume operation.

Figure 2-4 Adjust outlet isolation valve

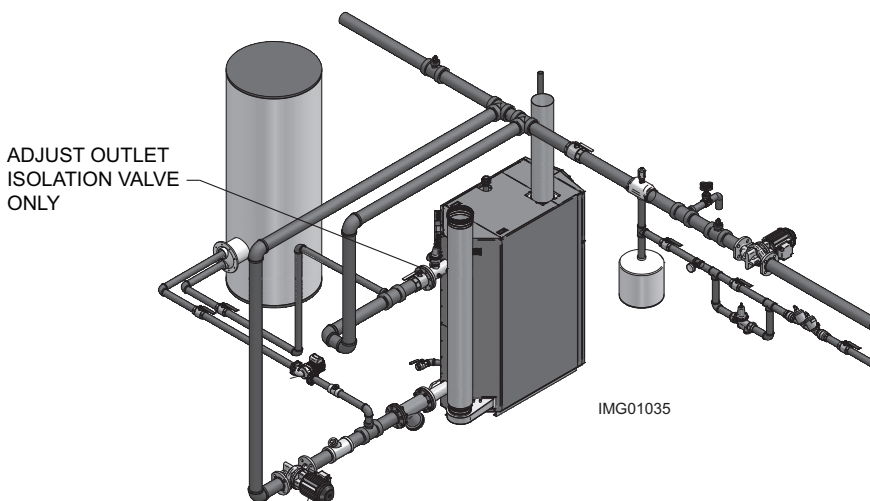

3 Troubleshooting

WARNING Label all wires prior to disconnection when servicing controls. Wiring errors can cause improper and dangerous operation. Always disconnect power to the boiler before servicing. Failure to comply could result in severe personal injury, death, or substantial property damage.

WARNING Never jumper (bypass) any device except for momentary testing as outlined in the Troubleshooting chart. Severe personal injury, death, or substantial property damage can result.

Before troubleshooting:

1. Have the following items:
 - a. Voltmeter that can check 120 vac, 24 vac, and 12 vdc.
 - b. Continuity checker.
 - c. Contact thermometer.
2. Check for 120 vac (minimum 102 vac to maximum 132 vac) to boiler.
3. Make sure thermostat is calling for heat and contacts are closed. Check for 24 vac between enable input and ground.
4. Make sure all external limit controls are installed and operating.

Check the following:

1. Wire connectors to control module are securely plugged in at the module and originating control.
2. Gas pressures:
 - Maximum: 14 inches w.c. (3.5 kPa) (natural and LP) with no flow (lockup) or with boiler on
 - Minimum: 4 inches w.c. (0.99 kPa) (NATURAL) or 8 inches w.c. (1.99 kPa) (PROPANE) with gas flowing (verify during boiler startup)

Check control module fuses

NOTICE ALWAYS check control module fuses before replacing control module or any major components (blower, etc.). If one of these fuses is blown, it can prevent the control module or other components from operating.

1. Turn OFF the power to the boiler at the external line switch.
2. Remove the upper and lower doors.
3. Remove the control panel cover.
4. Inspect fuses (reference FIG. 3-1).

Figure 3-1 Control Module Fuses

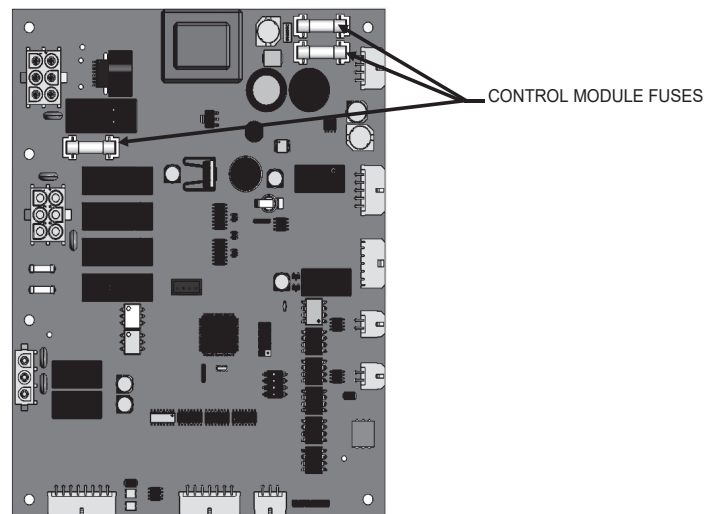

5. The boiler is shipped with replacement fuses in a plastic bag located inside the control panel.
6. If necessary, select the correct replacement fuse and replace any blown fuse(s).

WARNING Do not jumper fuse or replace with any fuse except as specified. Failure to comply could result in severe personal injury, death, or substantial property damage.

7. Re-install the control panel cover using the four (4) screws removed in Step 3. Re-install the upper and lower doors after fuse inspection.
8. Restore power to the boiler at the external line switch and verify boiler operation (Section 9 - Start-up in the Crest Installation and Operation Manual) after completing boiler service.

3 Troubleshooting

Table 3A Troubleshooting Chart - No Display

FAULT	CAUSE	CORRECTIVE ACTION
<p>No Display</p>	<ul style="list-style-type: none"> - No power supplied to the unit. - No LED's illuminated on the CON•X•US Interface control board. 	<ul style="list-style-type: none"> • Check external line switch, fuse, or breaker. • Check position of ON/OFF switch. Turn switch to the ON position. • Check 120 vac through the ON/OFF switch. • Check wiring harness connection between display board and main control board. Connect harness at both points.
	<ul style="list-style-type: none"> - Bad display, no LED's illuminated. 	<ul style="list-style-type: none"> • Check connection.
	<ul style="list-style-type: none"> - Bad display. 	<ul style="list-style-type: none"> • Replace the display.
<p>No Burner Operation</p>	<ul style="list-style-type: none"> - Main control board temperature set point satisfied. 	<ul style="list-style-type: none"> • Review temperature setting.
	<ul style="list-style-type: none"> - Remote thermostat satisfied. 	<ul style="list-style-type: none"> • Review remote thermostat setting.
	<ul style="list-style-type: none"> - Outside air temperature above Warm Weather Shutdown (WWSD) set point for main control board. 	<ul style="list-style-type: none"> • Check location of outside air sensor. Check resistance of outdoor air sensor and compare to Table 3C of this manual.
	<ul style="list-style-type: none"> - Unit locked out on fault. 	<ul style="list-style-type: none"> • Consult display for specific fault. Refer to fault descriptions in this manual for corrective actions.
<p>Unit Does Not Modulate Up to 100%</p>	<ul style="list-style-type: none"> - Ramp delay active. 	<ul style="list-style-type: none"> • Check ramp delay parameter settings.
		<ul style="list-style-type: none"> • Turn ramp delay feature off. See this manual for instructions on how to turn this feature off.
	<ul style="list-style-type: none"> - Boiler controlled by BMS. 	<ul style="list-style-type: none"> • Check BMS parameter settings.

3 Troubleshooting *(continued)*

Checking temperature sensors

The boiler temperature sensors (inlet water, outlet water, system water, flue, and outdoor air) are all resistance type devices. The following tables show the correct values for the sensors at various temperatures. Use an ohmmeter to read the resistance of the sensor at a known temperature. If the resistance of the sensor does not closely match its corresponding table, replace the sensor.

It is important to note that the flue and outlet water sensors each have two temperature sensing devices in one housing. These devices are designated as S1/S9 - outlet sensor and S3/S10 - flue sensor. Please reference the wiring diagram in the Crest Installation and Operation Manual for correct terminal location.

Table 3B - Inlet Water/System Sensor Resistance vs. Temperature

Temperature	Resistance	Temperature	Resistance
50	18,780	158	1,990
68	12,263	176	1,458
86	8,194	194	1,084
104	5,592	212	817
122	3,893		
140	2,760		

Table 3C - Outdoor Air Sensor Resistance vs. Temperature

Temperature	Resistance	Temperature	Resistance
-50	490,813	20	46,218
-40	336,606	30	34,558
-30	234,196	40	26,099
-20	165,180	50	19,900
10	118,018	60	15,311
0	85,362	70	11,883
10	62,465	80	9,299

Table 3D - Outlet Water & Pre-Mix Air Sensor Resistance vs. Temperature

Outlet	S1	R/Y		Outlet	S9	RW/Y	
Pre-Mix Air	S11	GY/Y				Temperature	Resistance
Temperature	Resistance	Temperature	Resistance	Temperature	Resistance	Temperature	Resistance
50	19,553	158	2,004	50	40,030	158	3,478
68	12,690	176	1,464	68	25,030	176	2,492
86	8,406	194	1,084	86	16,090	194	1,816
104	5,715	212	816	104	10,610	212	1,344
122	3,958			122	7,166		
140	2,786			140	4,943		

Table 3E - Flue Sensor Resistance vs. Temperature

Flue	S3	GY/Y		Flue	S10	W/Y	
Temperature	Resistance	Temperature	Resistance	Temperature	Resistance	Temperature	Resistance
50	40,030	158	3,478	50	258,500	158	16,870
68	25,030	176	2,492	68	125,500	176	12,000
86	16,090	194	1,816	86	80,220	194	8,674
104	10,610	212	1,344	104	52,590	212	6,369
122	7,166			122	35,270		
140	4,943			140	24,160		

3 Troubleshooting

Table 3F Troubleshooting Chart - Noisy System

FAULT	CAUSE	CORRECTIVE ACTION
<p>Noisy Operation</p>	<ul style="list-style-type: none"> - Supply gas problem. Natural gas pressures should be between 4 inches w.c. (1.0 kPa) and 14 inches w.c. and LP gas pressures should be between 8 inches w.c. (1.99 kPa) and 14 inches w.c. (3.5 kPa). 	<ul style="list-style-type: none"> • Refer to Section 6 - Gas Connections of the Crest Installation and Operation Manual for detailed information concerning the gas supply.
	<ul style="list-style-type: none"> - Gas/air mixture problem. 	<ul style="list-style-type: none"> • Refer to the Gas Valve Adjustment Procedure in this manual for the proper gas valve setting. Verify that the vent/air intake lengths do not exceed the maximum listed in the General Venting section of the Crest Installation and Operation Manual.
	<ul style="list-style-type: none"> - Dirty/damaged burner. 	<ul style="list-style-type: none"> • Refer to this manual for the burner removal and inspection procedure. Clean or replace the burner as necessary.
	<ul style="list-style-type: none"> - Air in the piping system. 	<ul style="list-style-type: none"> • Properly purge all air from the piping system.
	<ul style="list-style-type: none"> - Dirt or debris caught in the air intake that may be blocking inlet air. 	<ul style="list-style-type: none"> • Check or replace the filter.
<p>No Pump Operation - Boiler Pump System Pump or DHW Pump</p>	<ul style="list-style-type: none"> - Blown fuse. 	<ul style="list-style-type: none"> • Replace fuse F4 on the control board.
	<ul style="list-style-type: none"> - Faulty pump. 	<ul style="list-style-type: none"> • Replace pump.
	<ul style="list-style-type: none"> - Internal fault on control board. 	<ul style="list-style-type: none"> • Replace main control board.
	<ul style="list-style-type: none"> - Faulty pump relay. 	<ul style="list-style-type: none"> • Replace relay.
	<ul style="list-style-type: none"> - Incorrect parameter setting. 	<ul style="list-style-type: none"> • Reference the Boiler Pump Mode and System Pump Mode parameters in the Service section of this manual.
<p>No Blower Operation</p>	<ul style="list-style-type: none"> - Internal fault on control board. 	<ul style="list-style-type: none"> • Replace control board.
	<ul style="list-style-type: none"> - Faulty blower. 	<ul style="list-style-type: none"> • Replace blower.
	<ul style="list-style-type: none"> - Faulty blower relay. 	<ul style="list-style-type: none"> • Replace relay.
<p>Relief Valve Opening</p>	<ul style="list-style-type: none"> - System pressure exceeds relief valve setting. 	<ul style="list-style-type: none"> • Lower the system pressure below the rating of the supplied relief valve or replace the standard relief valve with a higher rated valve up to the maximum pressure of the heat exchanger 160 psi (40 kPa). • Improperly sized expansion tank.

3 Troubleshooting *(continued)*

Table 3G Troubleshooting Chart - Fault Messages Displayed on Boiler Interface

FAULT	DESCRIPTION	CORRECTIVE ACTION
<p>Gas Pressure SW Open (will require a manual reset once the condition has been corrected. Press the RESET button on the SMART TOUCH display to reset.)</p>	<p>Either the low gas pressure switch or the high gas pressure switches tripped.</p>	<ul style="list-style-type: none"> • Measure the supply gas pressure to determine cause of failure. Natural gas pressures should be between 4 inches w.c. (1.0 kPa) and 14 inches w.c. and LP gas pressures should be between 8 inches w.c. (1.99 kPa) and 14 inches w.c. (3.5 kPa). • Refer to Section 6 - Gas Connections of the Crest Installation and Operation Manual for detailed information concerning the gas supply. • Correct the supply gas pressure if necessary.
<p>Low Water Cutoff Open (will require a manual reset once condition has been corrected. Press the RESET button on the SMART TOUCH display to reset.)</p>	<p>The low water cutoff is not making.</p>	<ul style="list-style-type: none"> • Reset the LWCO from the RESET button on the front control panel. • Verify system is full of water and all air has been purged from the system. • Check for loose or misplaced jumpers if flow switch or LWCO is not installed.
	<p>Blown fuse.</p>	<ul style="list-style-type: none"> • Replace fuse F2 on the control board.
<p>Blocked Drain SW Open (will require a manual reset once condition has been corrected. Press the RESET button on the SMART TOUCH display to reset.)</p>	<p>The blocked drain switch has detected excessive condensate build up inside the unit.</p>	<ul style="list-style-type: none"> • Check condensate tube from unit to floor drain for proper installation and obstructions. • Inspect condensate trap for blockage. Clean if necessary. • Check for loose wiring connection at wire harness plug. • Bad blocked drain switch. Replace switch.
<p>APS Open (will require a manual reset once the condition has been corrected. Press the RESET button on the SMART TOUCH display to reset.)</p>	<p>Blocked flue/inlet pressure switch contacts are open.</p>	<ul style="list-style-type: none"> • Check the wiring connections to switch. Wires should be connected to the common and normally closed terminals. • Vent/air intake lengths exceed the maximum allowed lengths. Refer to Section 2 - General Venting of the Crest Installation and Operation Manual for proper lengths. • Check for obstruction or blockage in the vent/air intake pipes or at terminations. • Check reference hose and tubing connected to the pressure switch for blockage or obstruction. • Inspect the burner. Reference this manual for removal and cleaning procedures. Replace if necessary. • Inspect the heat exchanger. Reference this manual for removal and cleaning procedures. Replace if necessary. • Faulty air pressure switch. Replace switch. • Verify combustion air blower is operating. Replace if necessary. • Check/replace filter.

3 Troubleshooting

Table 3G (continued from previous page) *Troubleshooting Chart - Fault Messages Displayed on Boiler Interface*

FAULT	DESCRIPTION	CORRECTIVE ACTION
Anti-cycling	The main control board has received a call for heat too quickly after the previous call for heat has ended.	<ul style="list-style-type: none"> • The control board will release the call for heat after a set time period. • The control board will release the call for heat if the outlet temperature drops too quickly.
<p>Flame Failure (will require a manual reset once the condition has been corrected. Press the RESET button on the SMART TOUCH display to reset.)</p>	The unit has failed to prove main burner ignition. It will require a manual reset before attempting to fire again.	<ul style="list-style-type: none"> • Inspect spark electrode and associated wiring for damage and connection. Reference this manual for removal and cleaning procedures. Replace if necessary. • Visually check for presence of a spark from the view port. • Check for proper electrical grounding of the unit. • Check incoming supply gas pressure. Natural gas pressures should be between 4 inches w.c. (1.0 kPa) and 14 inches w.c. and LP gas pressures should be between 8 inches w.c. (1.99 kPa) and 14 inches w.c. (3.5 kPa). Refer to Section 6 - Gas Connections of the Crest Installation and Operation Manual for detailed information concerning the gas supply. • Verify that the vent/air intake pipes are correctly installed and that there are no obstructions. • If 120 vac is present at the main control board, check the wiring between the main control board and the gas valve. Replace the wiring if necessary. Do not disconnect the wiring from the gas valve and attempt to measure voltage at that point. The main control board can detect if the gas valve is not connected and will display the Gas Valve / Connection fault. • If 120 vac is present, check the outlet of the valve to ensure the valve is flowing gas. With a manometer connected to the outlet tap of the gas valve, when the unit is in the prepurge period, there should be a negative pressure present. When the valve is energized a change in pressure should occur. If the pressure change does not occur, the gas valve is not opening. Replace the gas valve. • Inspect flame sensors and associated wiring. Reference this manual for removal and cleaning procedures. Replace if necessary. • Inspect the burner. Reference this manual for removal and cleaning procedures. Replace if necessary. • Check/replace filter.

3 Troubleshooting *(continued)*

Table 3G (continued from previous page) *Troubleshooting Chart - Fault Messages Displayed on Boiler Interface*

FAULT	DESCRIPTION	CORRECTIVE ACTION
<p>Flame Fail Running (will require a manual reset once the condition has been corrected. Press the RESET button on the SMART TOUCH display to reset.)</p>	<p>The unit was running and lost the flame signal.</p>	<ul style="list-style-type: none"> • Inspect flame rods and associated wiring for damage and connection. Reference this manual for removal and cleaning procedures. Replace if necessary. • Check for proper electrical grounding of unit. • Check incoming supply gas pressure. Natural gas pressures should be between 4 inches w.c. (1.0 kPa) and 14 inches w.c. and LP gas pressures should be between 8 inches w.c. (1.99 kPa) and 14 inches w.c. (3.5 kPa). Refer to Section 6 - Gas Connections of the Crest Installation and Operation Manual for detailed information concerning the gas supply. • Verify that the vent/air intake pipes are installed correctly and there are no obstructions. • Inspect flame sensor and associated wiring. Reference this manual for removal and cleaning procedures. Replace if necessary. • Check combustion. • Inspect the burner. Reference this manual for removal and cleaning procedures. Replace if necessary. • Check/replace filter.
<p>Gas Valve / Relay Failure (will require a manual reset once the condition has been corrected. Press the RESET button on the SMART TOUCH display to reset.)</p>	<p>The main control board did not detect a gas valve.</p>	<ul style="list-style-type: none"> • Check wiring harness connection at the gas valve and at the main control board. • Replace the wire harness. • Replace the gas valve. • Replace the control board.

3 Troubleshooting

Table 3G (continued from previous page) Troubleshooting Chart - Fault Messages Displayed on Boiler Interface

FAULT	DESCRIPTION	CORRECTIVE ACTION
<p>Auto Reset High Limit</p>	<p>The outlet water temperature has exceeded the setting of the automatic reset high limit.</p>	<ul style="list-style-type: none"> • Verify that the system is full of water and that all air has been properly purged from the system. • Verify that the boiler is piped properly into the heating system. Refer to Section 5 - Hydronic Piping of the Crest Installation and Operation Manual for the proper piping methods for the Crest boiler. • Check 120 vac to boiler pump motor on a call for heat. If voltage is not present, check wiring back to the main control board. • Check the ARHL set point. • If 120 vac is present on a call for heat and the boiler pump is not operating, replace the pump. • If the system pump is a variable speed pump, ensure that the system flow is not less than the boiler flow. • If operating on something other than an outlet sensor, check temperature setting of the main control board. • If the optional manual reset high limit has tripped, check setting of the device. • Check resistance of water sensors and compare to Table 3B of this manual. Replace sensor if necessary. • Replace the main control board.

3 Troubleshooting *(continued)*

Table 3G (continued from previous page) *Troubleshooting Chart - Fault Messages Displayed on Boiler Interface*

FAULT	DESCRIPTION	CORRECTIVE ACTION
<p>Manual Reset High Limit Open (will require a manual reset once the condition has been corrected. Press the RESET button on the SMART TOUCH display to reset.)</p>	<p>The outlet water temperature has exceeded the setting of the high limit.</p>	<ul style="list-style-type: none"> • Verify that the system is full of water and that all air has been properly purged from the system. • Verify that the boiler is piped properly into the heating system. Refer to Section 5 - Hydronic Piping of the Crest Installation and Operation Manual for the proper piping methods for the Crest boiler. • Check voltage to boiler pump motor on a call for heat. If voltage is not present, check wiring back to the main control board. • Replace the pump relay if necessary. • If 120 vac is present on a call for heat and the boiler pump is not operating, replace the pump. • If the system pump is a variable speed pump, ensure that the system flow is not less than the boiler flow. • If operating on either an inlet or system supply sensor, check temperature setting of the main control board. • If the high limit has tripped, check setting of the device and the MRHL set point. • Check resistance of water sensors and compare to Table 3B of this manual. Replace sensor if necessary. • Replace high limit (if equipped). • Replace main control board.
<p>Fan Speed Low (will require a manual reset once the condition has been corrected. Press the RESET button on the SMART TOUCH display to reset.)</p>	<p>The actual fan RPM is 30% lower than what is being called for.</p>	<ul style="list-style-type: none"> • Vent/air intake lengths exceed the maximum allowed lengths. Refer to Section 2 - General Venting of the Crest Installation and Operation Manual for proper lengths. • Check for obstruction or blockage in the vent/air intake pipes or at terminations. • Check the wiring connections at the fan and at the main control board. • Replace the fan.
	<p>Blown fuse.</p>	<ul style="list-style-type: none"> • Replace fuse F2 on the control board.

3 Troubleshooting

Table 3G (continued from previous page) *Troubleshooting Chart - Fault Messages Displayed on Boiler Interface*

FAULT	DESCRIPTION	CORRECTIVE ACTION
<p>Fan Speed High (will require a manual reset once the condition has been corrected. Press the RESET button on the SMART TOUCH display to reset.)</p>	<p>The actual fan RPM is 30% higher than what is being called for.</p>	<ul style="list-style-type: none"> • Vent/air intake lengths exceed the maximum allowed lengths. Refer to Section 2 - General Venting of the Crest Installation and Operation Manual for proper lengths. • Check for obstruction or blockage in the vent/air intake pipes or at terminations. • Check the wiring connections at the fan and at the main control board. • Replace the fan.
<p>Louver Proving Sw Open</p>	<p>An optional remote proving switch is not making.</p>	<ul style="list-style-type: none"> • Check function of remote devices. • Check for loose or misplaced jumper if proving switch is not installed.
<p>Flue Temp High</p>	<p>The stack temperature has exceeded the set parameters for the boiler.</p>	<ul style="list-style-type: none"> • Inspect the heat exchanger. Reference this manual for the procedure on how to clean the flue side of the heat exchanger. • Inspect the flue sensor and associated wiring. Measure the resistance of the flue sensor and compare to Table 3E of this manual. Replace the sensor if necessary. • Verify that the vent/air intake pipes are properly installed and that there are no obstructions.
<p>Delta T High</p>	<p>The temperature rise across the heat exchanger has exceeded the set parameters for the boiler.</p>	<ul style="list-style-type: none"> • Verify that the system is full of water and that all air has been properly purged from the system. • Verify that the boiler is piped properly into the heating system. Refer to Section 5 - Hydronic Piping of the Crest Installation and Operation Manual for the proper piping methods for the Crest boiler. • Check for 120 vac to the boiler pump motor on a call for heat. If voltage is not present, check the wiring back to the main control board. Replace the main control board if necessary. • If 120 vac is present on a call for heat and the boiler pump is not operating, replace the pump. • Verify that the boiler pump is set to the proper speed or that the pump is the proper size. Reference Section 5 - Hydronic Piping of the Crest Installation and Operation Manual for boiler pump specifications. • Inspect the inlet and outlet sensors and associated wiring. Measure the resistance of the sensors and compare to the tables in this manual.

3 Troubleshooting *(continued)*

Table 3G *(continued from previous page) Troubleshooting Chart - Fault Messages Displayed on Boiler Interface*

FAULT	DESCRIPTION	CORRECTIVE ACTION
<p>Outlet Temp High</p>	<p>Outlet water temperature has exceeded the maximum outlet water temperature.</p>	<ul style="list-style-type: none"> • Verify that the system is full of water and that all air has been properly purged from the system. • Verify that the boiler is piped properly into the heating system. Refer to Section 5 - Hydronic Piping of the Crest Installation and Operation Manual for the proper piping methods for the Crest boiler. • Check for 120 vac to the boiler pump motor on a call for heat. If voltage is not present, check wiring back to the main control board. Replace the main control board if necessary. • If 120 vac is present on a call for heat and the boiler pump is not operating, replace the pump. • Verify that the boiler pump is set to the proper speed or that the boiler pump is the proper size. Reference Section 5 - Hydronic Piping of the Crest Boiler Installation and Operation Manual for boiler pump specifications. • Inspect the outlet sensors and associated wiring. Measure the resistance of the sensors and compare to the tables in of this manual.
<p>Parameter Programming Complete (will require a manual reset once the condition has been corrected. Press the RESET button on the SMART TOUCH display to reset.)</p>	<p>After downloading parameters from a laptop, the main control board must be reset.</p>	<ul style="list-style-type: none"> • Press the RESET button on the SMART TOUCH display panel.
<p>Sensor Open (will require a manual reset once the condition has been corrected. Press the RESET button on the display to reset.)</p>	<p>Either the inlet water or outlet water temperature sensor has been disconnected.</p>	<ul style="list-style-type: none"> • Check the sensors and their associated wiring. Repair or replace the sensor or wiring if damaged. • Measure the resistance of the sensors and compare the resistance to the tables in this manual. • Replace the sensor if necessary.
<p>Sensor Shorted (will require a manual reset once the condition has been corrected. Press the RESET button on the display to reset.)</p>	<p>Either the inlet water or outlet water temperature sensor has been shorted.</p>	<ul style="list-style-type: none"> • Check the sensors and their associated wiring. Repair or replace the sensor or wiring if damaged. • Measure the resistance of the sensors and compare the resistance to the tables in this manual. • Replace the sensor if necessary.
<p>Flue Sensor Open (will require a manual reset once the condition has been corrected. Press the RESET button on the display to reset.)</p>	<p>The flue sensor has been disconnected or removed from the flue.</p>	<ul style="list-style-type: none"> • Check the sensor and its associated wiring. Repair or replace the sensor or wiring if damaged. • Measure the resistance of the sensors and compare the resistance to the tables in this manual. • Replace the sensor in flue. • Replace the sensor if necessary.

3 Troubleshooting

Table 3G (continued from previous page) *Troubleshooting Chart - Fault Messages Displayed on Boiler Interface*

FAULT	DESCRIPTION	CORRECTIVE ACTION
<p>Flue Sensor Shorted (will require a manual reset once the condition has been corrected. Press the RESET button on the display to reset.)</p>	<p>The flue sensor has been shorted.</p>	<ul style="list-style-type: none"> • Check the sensor and its associated wiring. Repair or replace the sensor or wiring if damaged. • Measure the resistance of the sensors and compare the resistance to the tables in this manual. • Replace the sensor if necessary.
<p>Too Many Resets - Try Later</p>	<p>Too many manual resets have occurred during a 15 minute period.</p>	<ul style="list-style-type: none"> • Wait 15 minutes and try again. • Turn power off to unit, wait 30 seconds and then turn power back on.
<p>Internal Fault</p>	<p>The main control board has detected an internal fault.</p>	<ul style="list-style-type: none"> • Replace the main control board.
<p>Flue Temp Shutdown</p>	<p>The stack temperature has exceeded the set parameters for the boiler.</p>	<ul style="list-style-type: none"> • Inspect the heat exchanger. Reference this manual for the procedure on how to clean the flue side of the heat exchanger. • Inspect the flue sensor and associated wiring. Measure the resistance of the flue sensor and compare to Table 3E of this manual. Replace the sensor if necessary. • Verify that the vent/air intake pipes are properly installed and that there are no obstructions. • Replace the main control board.
<p>Delta T Shutdown</p>	<p>The temperature rise across the heat exchanger has exceeded the set parameters for the boiler.</p>	<ul style="list-style-type: none"> • Verify that the system is full of water and that all air has been properly purged from the system. • Verify that the boiler is piped properly into the heating system. Refer to Section 5 - Hydronic Piping of the Crest Installation and Operation Manual for the proper piping methods for the Crest boiler. • Check for voltage to the boiler pump motor on a call for heat. If voltage is not present, check the wiring back to the pump relay. Replace the pump relay if necessary. • If 120 VAC is present on a call for heat and the boiler pump is not operating, replace the pump. • Verify that the boiler pump is set to the proper speed or that the pump is the proper size. Reference Section 5 - Hydronic Piping of the Crest Installation and Operation Manual for boiler pump specifications.

3 Troubleshooting *(continued)*

Table 3G (continued from previous page) *Troubleshooting Chart - Fault Messages Displayed on Boiler Interface*

FAULT	DESCRIPTION	CORRECTIVE ACTION
Outlet Temp Shutdown	Outlet water temperature has exceeded the maximum outlet water temperature.	<ul style="list-style-type: none"> • Verify that the system is full of water and that all air has been properly purged from the system. • Verify that the boiler is piped properly into the heating system. Refer to Section 5 - Hydronic Piping of the Crest Installation and Operation Manual for the proper piping methods for the Crest boiler. • Check for voltage to the boiler pump motor on a call for heat. If voltage is not present, check wiring back to the pump relay. Replace the pump relay if necessary. • If 120 VAC is present on a call for heat and the boiler pump is not operating, replace the pump.
Writing/ Programming EEPROM Error	The main control board has detected an internal fault.	<ul style="list-style-type: none"> • Turn power OFF and back ON. • Replace the main control board.
CRC Parameter Error	The main control board has detected an internal fault.	<ul style="list-style-type: none"> • Turn power OFF and back ON. • Replace the main control board.
Wrong Error Code	The main control board has detected an internal fault.	<ul style="list-style-type: none"> • Press the RESET button on the SMART TOUCH display panel.
Flame Sense Out of Sequence 1 (will require a manual reset once the condition has been corrected. Press the RESET button on the display to reset.)	Flame Sensor 1 senses a flame while the gas valve is turned off.	<ul style="list-style-type: none"> • Clean Flame Sensor 1. • Replace control board.
Flame Sense Out of Sequence 2 (will require a manual reset once the condition has been corrected. Press the RESET button on the display to reset.)	Flame Sensor 2 senses a flame while the gas valve is turned off.	<ul style="list-style-type: none"> • Clean Flame Sensor 2. • Replace control board.
Flue Damper Switch Open	The flue damper proving switch is not closed when the flue damper is energized.	<ul style="list-style-type: none"> • Check that the flue damper is connected to the 3-pin connector on the rear of the boiler. • Check the wiring between the flue damper connector and the control board. • Check for 24VAC from the output of the flue damper transformer when the fan is running. • Check for 120VAC from the output of the flue damper transformer when the fan is running. • Check the wiring between the flue damper transformer and the control board. • Check fuse F4 on the control board. • Replace the flue damper. • Replace the control board.

3 Troubleshooting

Table 3G (continued from previous page) Troubleshooting Chart - Fault Messages Displayed on Boiler Interface

FAULT	DESCRIPTION	CORRECTIVE ACTION
<p>IO Expander Out Error</p>	<p>The control board detected an internal fault.</p>	<ul style="list-style-type: none"> • Turn the power OFF. Wait 15 seconds, then turn the power back ON. • Replace the control board.
<p>Failure ADC Controller (will require a manual reset once the condition has been corrected. Press the RESET button on the display to reset.)</p>	<p>A problem was detected with measuring one or more temperature sensors.</p>	<ul style="list-style-type: none"> • Check all connections between the temperature sensors and the control board. Make sure all connections are dry and secure. • Connect a PC to the control board and open the Status window. Look for temperature readings that are jumping by more than 1°F. • Check the resistance of all sensors (see this manual). • Replace the control board.
	<p>The control board has detected an internal fault.</p>	<ul style="list-style-type: none"> • Turn the power OFF. Wait 15 seconds, then turn the power back ON. • Replace the control board.
<p>Outlet Sensor Differential (will require a manual reset once the condition has been corrected. Press the RESET button on the display to reset.)</p>	<p>The readings from the two outlet temperature sensors are too far apart.</p>	<ul style="list-style-type: none"> • Check all connections between the outlet temperature sensors and the control board. Make sure all connections are dry and secure. • Check the resistance of the two outlet sensors (see this manual). • Replace the control board.
<p>Flue Sensor Differential (will require a manual reset once the condition has been corrected. Press the RESET button on the display to reset.)</p>	<p>The readings from the two flue temperature sensors are too far apart.</p>	<ul style="list-style-type: none"> • Check all connections between the flue temperature sensors and the control board. Make sure all connections are dry and secure. • Check the resistance of the two flue sensors (see this manual). • Replace the control board.

3 Troubleshooting *(continued)*

Combustion Analysis Procedure

1. Turn the main power off to the boiler by placing the “On/Off” switch in the OFF position.
2. Remove the fitting from the flue collector. **Note:** Combustion measurements will be made at this point.
3. Insert the probe from a combustion analyzer into the hole left by the removal of the fitting.
4. Turn the main power on to the boiler by placing the “On/Off” switch in the ON position.
5. Navigate to the Setup Screen from the Home Screen by pressing the SETUP button along the left side of the screen. Enter the installer password.
6. Select the Service Maintenance Screen. The tabs will scroll (up and down) to reveal more options.
On the Service Maintenance Screen place heater into Service Mode by selecting the START button, then selecting the low fire modulation point (FIG. 3-2).
7. Once the boiler has modulated to rate, measure the combustion. The values should be near the target listed in Table 3H (this page). CO levels should be less than 200 ppm for a properly installed unit. If the combustion is not near the target, reference the Troubleshooting Chart for possible causes and corrective actions.

8. Once the heater analysis is complete, test the safety shutoff device by turning the manual shutoff valve to the OFF position and ensuring the heater shuts down and registers an alarm. Open the manual shutoff valve and reset the control.
9. Turn the main power off to the boiler and replace the fitting into the flue pipe connection.
10. Ensure the boiler is placed back into normal operation.



WARNING You must replace the fitting to prevent flue gas spillage into the room. Failure to comply could result in severe personal injury, death, or substantial property damage.

Table 3H Flue Products

Natural Gas		
Units	*CO ₂ (Flue Port)	*O ₂ (Sensor)
ALL	9.5	3.6
Propane		
Units	*CO ₂ (Flue Port)	*O ₂ (Sensor)
ALL	10.5	4.4

*NOTE: The Hellcat Combustion System is designed to maintain constant combustion. CO₂ is the target combustion measured from the flue measurement port. O₂ is the target measurement of the active O₂ sensor in the combustion chamber. An O₂ measurement from the flue will vary from the O₂ measured in the combustion chamber.

Figure 3-2 Service Screen

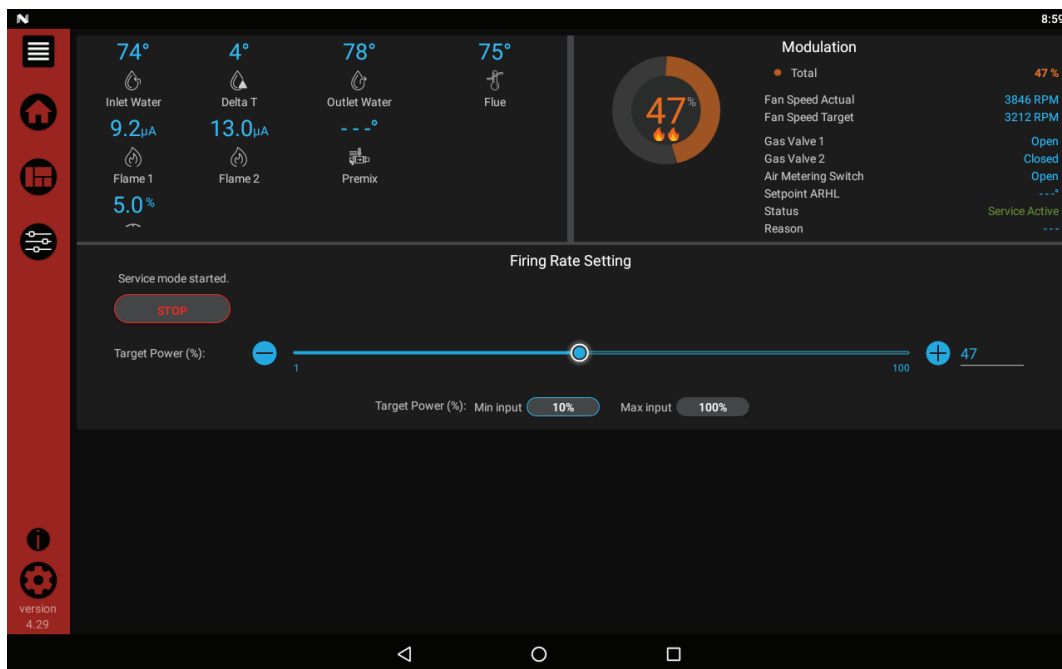

3 Troubleshooting

Table 3I Troubleshooting Chart - Combustion Levels

POSSIBLE CAUSE	CORRECTIVE ACTION
Vent/Air Intake Length or Obstruction	<ul style="list-style-type: none"> • Refer to Section 2 - General Venting of the Crest Installation and Operation Manual for the proper venting and air intake methods for the Crest boiler. • Check for obstructions at the vent/air intake terminals. • Check/replace filter.
Gas Supply Pressure	<ul style="list-style-type: none"> • Refer to Section 6 - Gas Connections of the Crest Installation and Operation Manual for the proper gas supply for the Crest boiler.
Dirty/Damaged Burner	<ul style="list-style-type: none"> • Refer to this manual for burner removal and cleaning procedures. • Replace burner if necessary.
Gas Valve Adjustment	<ul style="list-style-type: none"> • Refer to this manual for the gas valve adjustment procedure.

3 Troubleshooting *(continued)*

Gas valve adjustment procedure

CAUTION

Under normal operating conditions the gas valve should not need adjusting. Any adjustment should be done in conjunction with the commissioning sequence as detailed in the Start-up Section of the Crest Installation and Operation Manual.

Adjusting the gas valve's regulator adjustment screw (see FIG. 3-3) sets the manifold pressure used for the entire modulation range. The commissioning process allows each of the nine (9) control points to be adjusted individually.

Note: Turning the adjustment screw clockwise increases the CO₂ while decreasing the O₂ levels.

Note: Turning the adjustment screw counterclockwise decreases CO₂ while increasing the O₂ levels.

If combustion is still not within the specified range, repeat the procedure above. If after four (4) adjustments and the combustion is still not within the specified range, revisit the possible causes in Table 3I on page 56 or gas valve replacement may be required.

Figure 3-3 Gas Valve Adjustment_Regulator Adjustment Screw

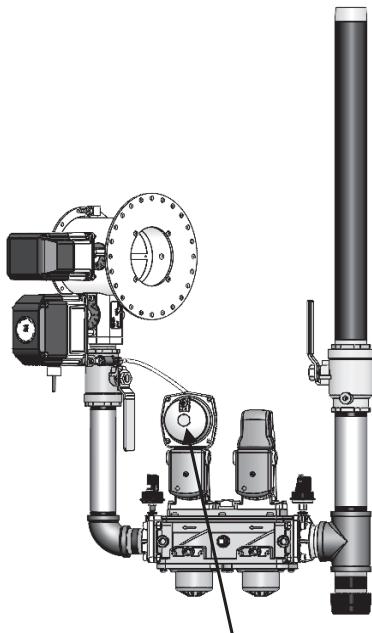

REGULATOR ADJUSTMENT SCREW

Revision Notes: Revision A (PCP #3000047204 / CN #500034581)
initial release.

MM #100343237_DIR #2000600598_Rev A
10/21