



PARTS & SERVICE MANUAL

Impinger 3270

Impinger 3270 CE

REV: 5/2/12

Lincoln Foodservice Products, LLC
1111 North Hadley Road
Fort Wayne, Indiana 46804
Telephone: 260.459.8200
Fax: 888.790.8193
Technical Support: 800.678.9511
lincolnfp.com

Table of Contents

MODEL NUMBER KEY.....	3
SEQUENCE OF OPERATION - DOMESTIC.....	4
SEQUENCE OF OPERATION - INTERNATIONAL.....	5
SCHEMATIC DIAGRAM - DOMESTIC.....	6
SCHEMATIC DIAGRAM - INTERNATIONAL.....	7
TROUBLESHOOTING GUIDE - DOMESTIC.....	8
TROUBLESHOOTING GUIDE - INTERNATIONAL.....	13
REMOVAL, INSTALLATION & ADJUSTMENTS.....	18
OVEN CONTROL – PROGRAMMING.....	25
GENERAL VIEW.....	27
CONTROL BOX, LEFT SIDE - DOMESTIC.....	29
CONTROL BOX, RIGHT SIDE - DOMESTIC.....	31
CONTROL BOX, LEFT SIDE - INTERNATIONAL.....	33
CONTROL BOX, RIGHT SIDE – INTERNATIONAL.....	35
REAR WALL MOTOR ASSEMBLY.....	37
CONVEYOR, FULL BELT.....	39
CONVEYOR, SPLIT BELT.....	41

MODEL NUMBER KEY

EXAMPLE: 3270-000-N-K1962 or 3270-000-NCE-K1962

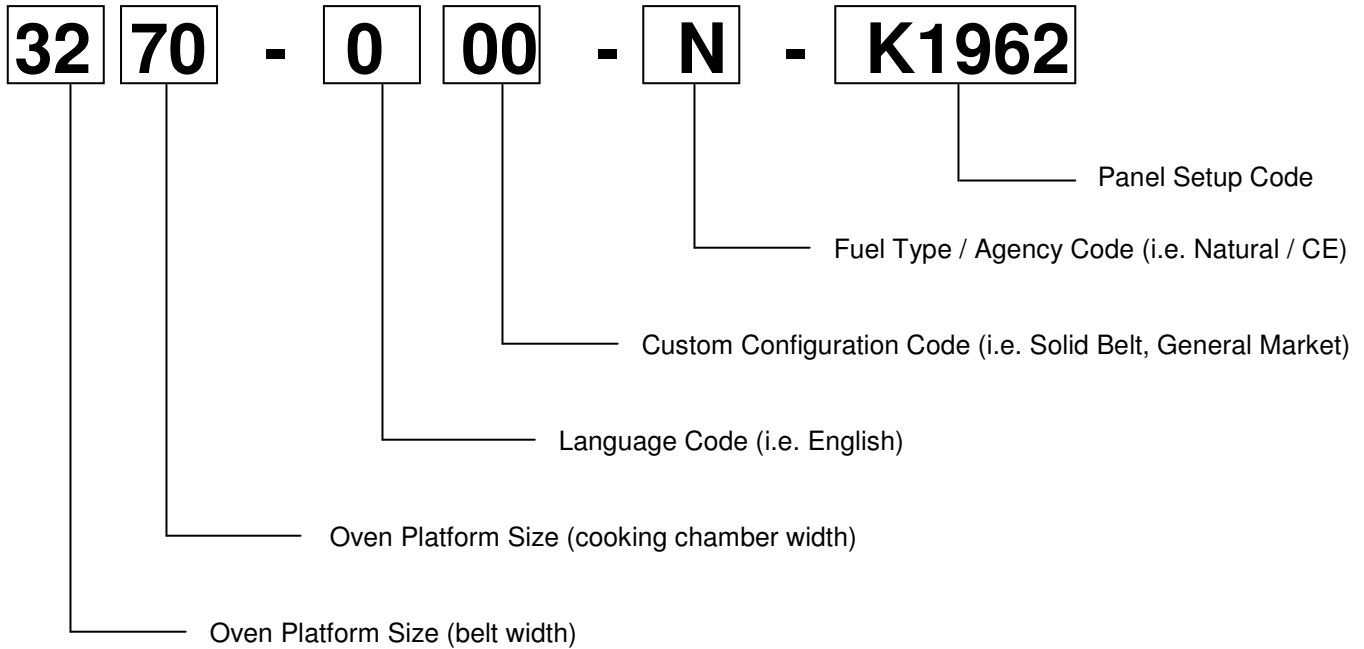

LANGUAGE CODE TABLE

CODE	LANGUAGE	COUNTRY		CODE	LANGUAGE	COUNTRY
0	English	Dom. & Int. Default		N	Finnish	Finland
B	French	France/Luxembourg		O	Restricted	---
C	German	Germany		P	Norwegian	Norway
D	Italian	Italy		Q	English	Japan
E	Spanish	Spain		R	Swedish	Sweden
F	English	UK/India/Africa/Hungary		S	English	Australia
G	Spanish	Mexico/Latin America		T	Mandarin	China
H	Portuguese	Portugal		U	Restricted	---
I	Not Used	---		V	English	Pacific Rim/Korea
J	Danish	Denmark		W	English	Middle East
K	Dutch & French	Belgium		X	Not Used	---
L	Dutch	Netherlands		Y	Not Used	---
M	Greek	Greece		Z	Not Used	---

FUEL TYPE TABLE

CODE	TYPE		CODE	TYPE
N	Natural Gas		S	480V 3PH 60Hz
L	LP Gas		V	120/240V 3PH 60Hz
J	208V 1PH 60Hz		B	230V 1PH 50Hz
M	220V 1PH 60Hz		D	380/220V 1PH 50Hz
P	240V 1PH 60Hz		G	415/240V 1PH 50Hz
R	208V 3PH 60Hz			

SEQUENCE OF OPERATION - DOMESTIC

Model	Gas Type	Voltage	Hz.	Phase
3270	Natural Gas	120 VAC	60 Hz	1 Phase
3270	LP Gas	120 VAC	60 Hz	1 Phase

POWER SUPPLY	Electrical power to be supplied to the oven by a three conductor cordset. Voltage from the black conductor to the white conductor to be 120VAC. <ul style="list-style-type: none"> - White conductor is Neutral - Green conductor is Ground
CONTROL BOX AUTO COOL DOWN	When the temperature in either one of the control boxes reaches 120°F ± 3°F (49°C ± 1.7°C), the cooling fan thermostats will switch power to the cooling fans. The thermostats will interrupt power to the cooling fans when the temperature falls to 100°F ± 3°F (37°C ± 1.7°C).
MAIN FAN CIRCUIT	120VAC is permanently supplied through a 15 amp fuse to the normally open double pole power switch, to a normally open set of contacts on the main fan relay and the normally open cooling fan thermostats. Closing the power switch supplies 120VAC to the coil of the time delay relay. These normally open contacts now close supplying 120VAC to the time delay which then supplies 120VAC to the main fan relay coil closing the normally open contacts, which then supplies 120VAC to the main fan motors.
BURNER CIRCUIT	Closing the Oven Power Switch also supplies 120VAC to the burner blower motors. NOTE: This oven utilizes two (2) complete Burner/Temperature Control systems. The sequence of operations is the same for each system. 120VAC is supplied, through the Centrifugal Switch of the Main Fan Motor (this switch closes when the Main Fan reaches approximately 900 R.P.M.) to the primary of Ignition Control Transformers. As the Burner Blower reaches approximately 1600 R.P.M., its internal centrifugal switch will close, supplying 24VAC to the ignition control. The Ignition Control operates on both 24VAC and 120VAC. When the control is energized by 24VAC, 120VAC is switched to the Hot Surface Igniter for 45 seconds for Hot Surface Igniter warm up. The igniter glows red, 24VAC is switched to the MV/PV gas valve which opens, and ignition should now occur. If ignition does not occur in 6 seconds, the control will lock out. To recycle after lockout, turn off the main oven switch for 45 seconds and then turn the switch back on.
TEMPERATURE CONTROL	When the Oven Power Switch closes, power is supplied to the Oven Control Transformers which supply 24VAC to the oven controls (TWO CONTROLS – one for the left side of oven, one for the right side of oven). The oven control is set to a desired temperature. Thermocouples will provide varying millivolts to the oven controllers. The oven controllers supply 3-24VDC to the modulating valve to maintain desired temperature.
CONVEYOR DRIVE	Line voltage (120VAC) is supplied to the conveyor motor. The conveyor speed is controlled by an increase or decrease in frequency for the conveyor controller. Secondary voltage, 24VAC, is supplied to the oven control. Setting the oven control to the desired time, outputs line voltage, through a reversing switch, to the conveyor motor. Speed is monitored via frequency output from the hall effect sensor.
NOTE: The conveyor control uses a hall effect sensor and magnet mounted in the conveyor motor that senses the motor speed. Any change in motor load (± R.P.M.) is detected by the sensor and the frequency to the motor is adjusted accordingly.	

SEQUENCE OF OPERATION - INTERNATIONAL

Model	Gas Type	Voltage	Hz.	Phase
3270 CE	Natural Gas	230 VAC	50 Hz	1 Phase
3270 CE	LP Gas	230 VAC	50 Hz	1 Phase

POWER SUPPLY	Electrical power to be supplied to the oven by a three conductor service.
CONTROL BOX AUTO COOL DOWN	When the temperature in either one of the Control Boxes reaches $49^{\circ}\text{C} \pm 1.7^{\circ}\text{C}$, ($120^{\circ}\text{F} \pm 3^{\circ}\text{F}$) the Cooling Fan Thermostats will switch power to the Cooling Fans. The thermostats will interrupt power to the Cooling Fans when the temperature falls to $37^{\circ}\text{C} \pm 1.7^{\circ}\text{C}$ ($100^{\circ}\text{F} \pm 3^{\circ}\text{F}$).
MAIN FAN CIRCUIT	Power is permanently supplied through a 10 amp fuse, through the normally closed emergency stop button, to the normally open double pole power switch, to a normally open set of contacts on the main fan relay and the normally open cooling fan thermostats. Closing the power switch supplies line voltage to the coil of the time delay relay. These normally open contacts now close enabling the time delay which then supplies line voltage to the main fan relay. As these normally open contacts close, line voltage is supplied to the main fan motors.
BURNER CIRCUIT	Closing the oven power switch supplies line voltage, through the main fan air pressure switch, through the normally closed oven cavity hi-limit thermostat, to the ignition control. The combustion motor is now energized; the normally open combustion air pressure switch closes upon sensing air. After a prepurge period between 30 and 60 seconds, the spark and main gas valve are energized. Ignition should now occur.
TEMPERATURE CONTROL	When the Oven Power Switch closes, power is supplied to the Oven Control transformers which supply 24 VAC to the Oven Controls (TWO CONTROLS one for the oven's left side, one for the oven's right side). The Oven Control is set to a desired temperature. Thermocouples will provide varying millivolts to the Oven Controllers. The Oven Controllers supply 3-24 VDC to the modulating valve to maintain desired temperature.
CONVEYOR DRIVE	Line voltage is supplied to the conveyor motor. The Conveyor speed is controlled by an increase or decrease in frequency from the Conveyor Controller. Secondary voltage, 24VAC, is supplied to the oven control. Setting the oven control to the desired time, outputs line voltage, through a reversing switch, to the conveyor motor. Speed is monitored via a frequency output from the hall effect sensor.
NOTE: The conveyor control uses a hall effect sensor and magnet mounted in the conveyor motor that senses the motor speed. Any change in motor load (\pm R.P.M.) is detected by the sensor and the frequency to the motor is adjusted accordingly.	

SCHEMATIC DIAGRAM - DOMESTIC MODEL 3270 120V 60HZ 1PH NATURAL or LP GAS

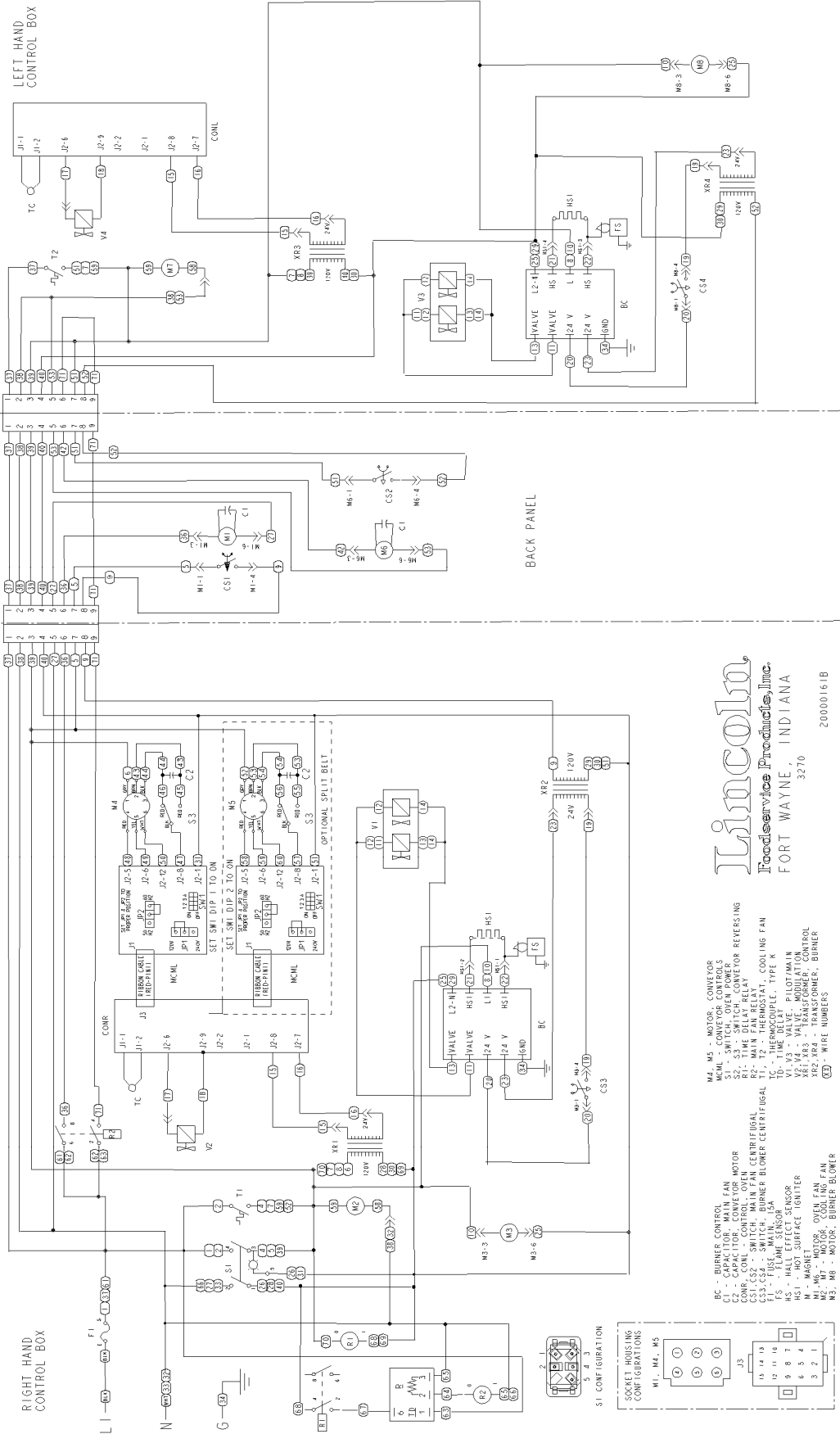

SCHEMATIC DIAGRAM - INTERNATIONAL MODEL 3270 CE 230V 50HZ 1PH NATURAL or LP GAS

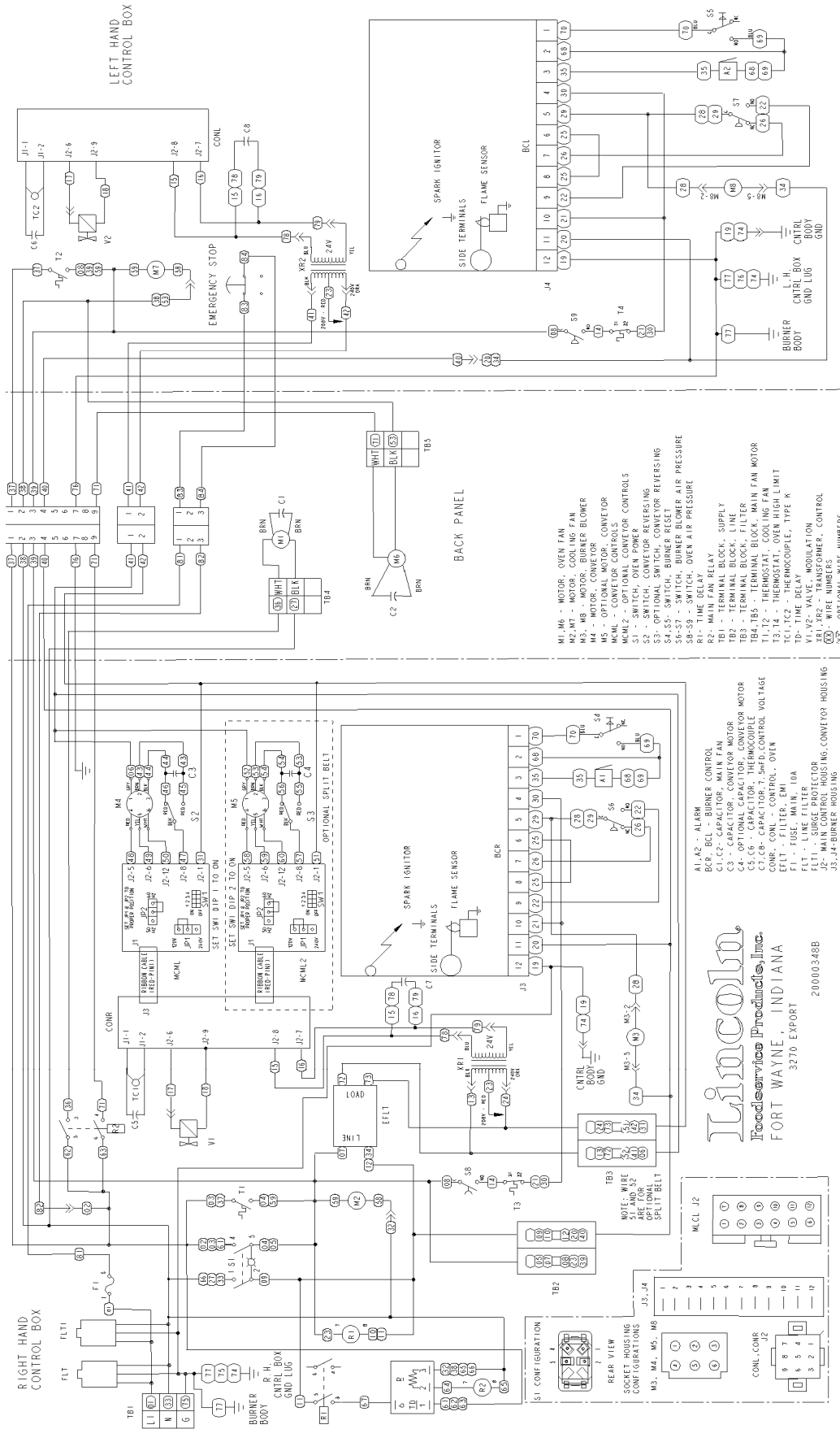

TROUBLESHOOTING GUIDE - DOMESTIC

Model Number	Gas Type	Voltage	Hz.	Phase
3270	Natural Gas	120 VAC	60 Hz	1 Phase
3270	LP Gas	120 VAC	60 Hz	1 Phase

SYMPTOM	POSSIBLE CAUSE	EVALUATION
Oven fan will not run	Incoming Power Supply	Check breakers, reset if required. Check power plug to be sure it is firmly in receptacle. Measure the incoming power. Call power company if needed.
	Fuse, 15 Amp	Check, replace if necessary.
	Fuse Holder	Check, replace if necessary.
	Main Oven Switch	Check continuity between switch terminals. Replace if necessary.
	Time Delay Relay	Check for 120 VAC to the relay coil. If voltage is not present, trace wiring back to the oven power switch. If voltage is present, check to insure contacts are closing.
	Time Delay	120 VAC is permanently supplied to the time delay. If no voltage is present, trace wiring back to fuse and incoming power. Neutral side of time delay coil is switched by the time delay relay. When the time delay is enabled, it supplies 120 VAC to coil of main fan relay.
	Main Fan Relay	Check for 120 VAC to main fan relay coil. If no voltage is present, trace back to time delay. If 120 VAC is supplied to main fan relay coil, ensure the contacts of main fan relay are closing by checking for 120 VAC on terminals #4 to a neutral and #8 to a neutral (these are the terminal numbers on the main fan relay). If contacts are not closing, replace the relay. Each terminal supplies a main fan motor with 120 VAC.
	Main Fan Motor	Check for 120 VAC at motor. If voltage is present and motor doesn't turn, WITH POWER OFF check for opens, shorts, or grounds. Turn fan blade to check for locked rotor. Replace as needed.
Capacitor	WARNING: Capacitor has a stored charge, discharge before testing. Check for shorts or grounds, replace as needed. Inspect for any visible damage. If the top of the capacitor appears to be swollen, replace capacitor.	
No control box cooling	Incoming Power	Check main circuit breakers and reset, if required. Call power company if needed.
	Fuse, 15 Amp	Check, replace if necessary.
	Fuse Holder	Check, replace if necessary.
	Main Oven Switch	Check continuity between switch terminals. Replace if necessary.
	Cooling Fan(s)	120 VAC should now be at the fan motor. If voltage is present and motor doesn't turn, WITH POWER OFF, check

		motors for shorts or opens. Check for locked rotor. Replace if necessary.
No automatic control box cooling	Incoming Power Supply	Check circuit breakers. Reset if required. Call power company if needed.
	Fuse, 15 Amp	Check, replace if necessary.
	Fuse Holder	Check, replace if necessary.
	Cooling Fan Thermostat	Check the cooling fan thermostat. (Thermostat closes at 120°F and opens at 100°F.) With the cooling fan thermostat preheated, check for continuity. If switch is open, replace.
	Cooling Fan(s)	120 VAC should be at the motor. If voltage is present, WITH POWER OFF, check for locked rotor. Check motor for shorts, opens, or grounds.
Oven will not heat	Gas Supply	Check manual gas valves and flexible gas line connection. Also check for adequate gas supply. NOTE: Natural Gas supply to oven – min. 7 in. W.C. LP Gas supply to oven – min. 11 in. W.C.
	Main Fan	If not operating, refer to “oven fan will not run”.
NOTE: These ovens utilize 2 complete burner/temperature control systems. Each system will follow the same troubleshooting sequence.		
Oven will not heat	Centrifugal Switch of Main Fan Motor	Check for 120 VAC supplied to the centrifugal switch. If voltage is not present, trace the wiring back to the oven power switch. Check for 120 VAC out of the centrifugal switch. If voltage is supplied to the centrifugal switch, and motor is running but there is no voltage out of the centrifugal switch, replace the fan motor. (NOTE: See Schematic Diagram of proper wire numbers on motors.)
	Burner Blower Motor	If no 120 VAC to blower motor, trace wiring back to oven power switch. Check for 120 VAC supply to the burner blower motor, if 120 VAC is present and motor does not turn, replace the motor.
	Burner Transformer	Check for 120 VAC to primary of the 24 VAC ignition control transformer. If voltage is not present, trace wiring back to the centrifugal switch of main fan motor. If voltage is present, check for 24 VAC at the secondary. If no secondary voltage is present, replace the transformer.
	Centrifugal Switch of Burner Blower Motor	Check for 24 VAC supply to the centrifugal switch of burner blower motor (see Schematic for proper wire numbers). If no voltage is present, trace wiring back to the transformer. If voltage is present, check for 24 VAC at the output of the centrifugal switch. If there is no output and the burner blower motor is running, replace the burner blower motor.
	Ignition Control	Check for 24 VAC supply to the ignition control at terminals marked 24V and 24V. If voltage is not present, trace wiring back to the centrifugal switch of burner blower motor. Check for 120VAC supply to the ignition control at

Oven will not heat (continued)		terminals L1 and L2. If no voltage is present, trace wiring back to oven power switch. If the above checks are okay, proceed. When 24 VAC is applied, the ignition control should switch 120VAC to the hot surface igniter for 45 seconds. Check across the (2) terminals marked HIS. If no voltage is present, replace the ignition control.
	Hot Surface Igniter (Located inside Burner Assembly)	If 120VAC is present at HSI terminals, visually check to see that the hot surface igniter is heating (igniter may be viewed through port glass in end of burner tube). The igniter should glow bright red. Check all connections to be sure they are tight. If the igniter does not heat, replace.
	Ignition Control	After 45 seconds of hot surface igniter pre-heat, the ignition control will switch 24 VAC to the gas control valves for 6 seconds. Check for 24 VAC output from the ignition control and across terminals marked "valve" and "valve". If no voltage is present, replace the ignition control. NOTE: The ignition control contains a safety lockout circuit. If a flame is not detected within 6 seconds after the gas control valve is energized, the ignition control will lockout. To reset, turn the power switch "off", wait 45 seconds and switch the system "on" to retry ignition.
	Gas Control Valves	Check for 24 VAC supplied to the pilot/main gas valves (dual valve). If voltage is present, the valves should open. Check the output gas pressure at the pressure tap located on the burner manifold. Gas pressure should measure approximately .6 in. W.C. If there is no gas pressure and the voltage is supplied to valves, check piping for obstructions.
Flame will not stay on	Hot Surface Igniter	The ignition control will keep the gas control valves energized for 6 seconds. At the end of 6 seconds the hot surface igniter must sense a flame or the ignition control will go to into lockout. (The ignition control requires a minimum of 0.8 micro-amps D.C.) If you detect a flame but only for the 6 second trial, check the flame sensing operation. Connect a digital multimeter (capable of measuring D.C. micro-amps) between the "ground" terminal on the ignition control and the ground lead. NOTE: This is a current measurement and the meter must be connected in series. NOTE: The D.C. micro-amp test must be conducted in series. NOTE: The D.C. micro amp test must be conducted with the oven in low flame (bypass) operation. Set the temperature control to its lowest setting.
	Power Supply	If there is sufficient micro-amp current and the 120VAC polarity is correct but the flame will not stay lit, check for proper ground connection for the ignition control. If ground is good, replace the ignition control.
NOTE: Flame should be lit at this time.		
Low flame is on but no main flame	Oven Control	Adjust temperature to maximum setting and check for 3-24 VDC at terminals J2-6 & J2-9 on oven control. If 3-24 VDC is present and unit is not heating, refer to "Modulating Valve" for next check. If 3-24 VDC is not present, proceed.
	Thermocouple Probe	WITH POWER ON AND THERMOCOUPLE LEADS

Low flame is on but no main flame (continued)		ATTACHED TO THE TEMPERATURE CONTROL BOARD: Measure the D.C. millivolt output of these leads. Refer to thermocouple chart in "Removal and Installation" section of service manual for proper readings. If these readings are not achieved, replace the thermocouple. If these readings are achieved with temperature at maximum setting, replace the oven control.
	Modulating Valve	With temperature at maximum setting, check for 3-24 VDC at the modulating valve. If no voltage is present, trace wiring back to the oven control terminals J2-6 & J2-9. If voltage is present, check the output gas pressure at the pressure tap located on the burner manifold. If voltage is present and gas pressure is not exceeding .6 in. W.C. at the burner manifold, replace modulating valve.
Intermittent heating	Thermal/Overload of Main Fan and Burner Blower Motors	The main fan motors and the burner blower motors are equipped with internal thermal protection and will cease to operate if overheating occurs. As the motors overheat and then cool, this will cause the units to cycle on and off intermittently. Improper ventilation or improper maintenance may cause this. Also, most of the problems listed under "oven will not heat" can cause intermittent failure.
Conveyor will not run	Power Supply	Check incoming voltage supply at line 1 to neutral. There should be a voltage reading of 120VAC. If not present, check breakers.
	15 Amp Fuse	Check and/or replace.
	Fuse Holder	Check and/or replace.
	Main Fan Switch	Check continuity between switch terminals.
	Oven Control Transformer	Check for supply voltage to primary of transformer. If no voltage is present, trace wiring back to the main oven switch. If voltage is present, check for 24VAC at transformer secondary. If there is primary voltage but no secondary voltage, replace transformer. If secondary voltage is present, proceed.
	Switch, Conveyor Reversing	Check for continuity between switch terminals. Replace switch as needed.
	Conveyor Motor	Check for supply voltage to the motor. If no voltage is present, trace wiring back to the reversing switch. If no voltage at switch, replace conveyor control. If voltage is present, check motor windings for opens or shorts. WITH POWER OFF: Check the motor windings as follows: Grey to Black – 38 ohm approx. Grey to Brown – 38 ohm approx. Brown to Black – 75 ohm approx. If any of the above fail, replace motor.
	Conveyor Motor Capacitor	Check for shorts or grounds. Replace capacitor as needed. WARNING: Capacitor has a stored charge. Discharge before testing!

Conveyor will not run (continued)	Conveyor	Check for any mechanical problems in the conveyor assembly. Check for damaged or torn belting. Check conveyor shaft bearings for damage or excessive wear. Repair or replace conveyor components as needed.
	Oven Control	Check output voltage from oven control to hall effect sensor (sensor is located in conveyor motor). Measure voltage at the motor connector, red wire and yellow wire. Voltage should be approx. 10VDC. If no voltage is present, trace wiring back to the oven control. If there is no voltage output present at the oven control, replace the oven control.
Conveyor runs but no speed control	Motor, Conveyor	If there is voltage supplied to the hall effect sensor, check for frequency output from the hall effect sensor. Measure frequency across the yellow and white wires at the motor connector. Frequency readings should be between 25 – 500 Hz. If these readings are not achieved, replace the conveyor motor. If these readings are achieved, proceed.
	Oven Control	If the hall effect sensor readings are correct but there is no speed indicated on the display, replace the oven control.

TROUBLESHOOTING GUIDE - INTERNATIONAL

Model Number	Gas Type	Voltage	Hz.	Phase
3270 CE	Natural Gas	230 VAC	50 Hz	1 Phase
3270 CE	LP Gas	230 VAC	50 Hz	1 Phase

SYMPTOM	POSSIBLE CAUSE	EVALUATION
Oven fan will not run	Incoming Power Supply	Check breakers, reset if required. Check power plug to be sure it is firmly in receptacle. Measure the incoming power. Call power company if needed.
	Fuse, 10 Amp	Check, replace if necessary.
	Fuse Holder	Check, replace if necessary.
	Emergency Stop Button	This is a normally closed switch. Be sure button is re-set. Check continuity between switch terminals. If switch is open, replace Emergency stop button.
	Main Oven Switch	Check continuity between terminals. Replace if necessary.
	Time Delay Relay	Check for line voltage to the relay coil. If voltage is not present, trace wiring back to the oven power switch. If voltage is present, check to insure contacts are closing. Replace as needed.
	Time Delay	Line voltage is permanently supplied to terminal #1 of the time delay. If no voltage present trace wiring back to fuse and incoming power. Neutral side of time delay coil is switched by the time delay relay. When the time delay is enabled, line voltage is supplied to coil of main fan relay.
	Main Fan Relay	Check for line voltage to main fan relay coil. If no voltage is present, trace wiring back to time delay. If line voltage is supplied to main fan relay coil, ensure the contacts of main fan relay are closing by checking for output voltage from relay contacts. If contacts are not closing, replace relay. Each terminal supplies a main fan motor with line voltage.
	Main Fan Motor	Check for line voltage at motor. If voltage is present and motor doesn't turn, WITH POWER OFF, check for opens, shorts, or grounds. Turn fan blade to check for locked rotor. Replace as needed.
Capacitor	WARNING: Capacitor has a stored charge, discharge before testing. Check for shorts or grounds, replace as needed. Inspect for any visible damage. If the top of the capacitor appears to be swollen, replace capacitor.	
No control box cooling	Incoming Power	Check main circuit breakers and reset, if required. Call power company if needed.
	Fuse, 10 Amp	Check, replace if necessary.
	Fuse Holder	Check, replace if necessary.
	Main Oven Switch	Check continuity between terminals. Replace if necessary.
	Cooling Fan(s)	Line voltage should now be at the fan motor. If voltage is

		present and motor doesn't turn, WITH POWER OFF, check motors for shorts or opens. Check for locked rotor. Replace if necessary.
No automatic control box cooling	Incoming Power Supply	Check circuit breakers. Reset if required. Call power company if needed.
	Fuse, 10 Amp	Check, replace if necessary.
	Fuse Holder	Check, replace if necessary.
	Cooling Fan Thermostat	Check the cooling fan thermostat. Thermostat closes at 49°C (120°F) and opens at 37°C (100°F). With the cooling fan thermostat preheated, check for continuity. If switch is open, replace.
	Cooling Fan(s)	Line voltage should be at the motor. If voltage is present, WITH POWER OFF, check for locked rotor. Check motor for shorts, opens, or grounds.
Oven will not heat	Gas Supply	Check manual gas valves and flexible gas line connection. Also check for adequate gas supply. NOTE: NAT Gas supply to oven – min. 7" W.C. (1.74kPa) LP Gas supply to oven – min. 11" W.C. (2.73kPa)
	Main Fan	If not operating, refer to "oven fan will not run".
NOTE: These ovens utilize 2 complete burner/temperature control systems. Each system will follow the same troubleshooting sequence.		
Oven will not heat	Air Pressure Switch of Main Fan Motor	Check air pressure switch terminals for supply voltage to terminals COM and NO. If voltage is present on one side only, check for air tube blockage or misalignment. If these are okay, adjust air pressure switch or replace switch as needed.
	Oven Cavity Hi-Limit Thermostat	Terminals are normally closed, opens at 350C (660F). If open, reset and test oven for proper operation. If thermostat will not hold for maximum temperature, and oven is not exceeding control setting, check for proper location of the capillary bulb in its spring holder. If above checks are okay. Replace hi-limit thermostat.
	Ignition Control	Check for supply voltage to ignition control at terminal #1 and neutral. If no voltage is present, trace wiring back to hi-limit thermostat. If voltage is present, check for supply voltage to burner blower motor at terminal #8 and neutral. If no voltage is present, wait 30 seconds reset ignition control, and re-try. If the above fails, replace ignition control.
	Burner Reset Switch	Switch is normally open. Check to see that the switch closes when reset button is pushed. Replace as needed.
	Burner Blower Motor	Check for supply voltage to burner blower motor. If no voltage is present, trace wiring back to ignition control. WITH POWER OFF: Turn blower wheel to check for locked rotor. If supply voltage is present, and motor does not run, replace burner blower motor.

Oven will not heat (continued)	Air Pressure Switch of Burner Blower Motor	Check for air pressure switch to be switching from “NC” to “NO”. Check for air tube blockage or misalignment. Adjust air pressure switch. If the above fails, replace air pressure switch.
	Ignition Control	A pre-purge time of 30 to 60 seconds occurs after burner blower motor starts. Check for high voltage spark output from the ignition control. If there is no high voltage spark output, check the reset button for the ignition control. If there is still no high voltage output, replace the ignition control.
	Spark Cable	Check spark cable for loose terminations. Verify resistance to be between 514Ω and 1068Ω. Replace if necessary.
	Igniter / Sensor Assembly (Located inside Burner Assembly)	Check for visible damage to the igniter/sensor assembly. If there is visible damage to the igniter/sensor assembly, replace. Check the spark gap (.096” 2.44mm). If there is no visible damage to the components, and no spark, replace the igniter/sensor assembly. Also check for frayed or damaged wires in burner tube. Replace components as needed.
	Ignition Control	Gas valve should open as the ignition control generates the high voltage spark. Check for supply voltage to pilot valve at terminal #5 and neutral. If no voltage is present, check reset button for the ignition control. If there is still no voltage to the pilot valve, replace ignition control.
	Gas Control Valves	Check for supply voltage to pilot valve at terminal #5 to neutral, if there is no voltage, trace wiring back to ignition control. If there is supply voltage, connect a manometer to the pressure tap fitting in the gas line. If there is voltage to the pilot valve, but there is no gas pressure, replace gas valve.
Flame will not stay on	Flame Sensor	To check flame sensor operation, connect a digital multimeter (capable of measuring D.C. microamps) between the flame sensor wire and flame sensor connection on the ignition control. Flame sensor current is to be 0.7 microamps, minimum. If these readings are not achieved, replace igniter/sensor assembly. Also check for any type of damage to flame sensor wire and connections. NOTE: The D.C. microamp test must be conducted with the oven in low flame (bypass) operation.
	Power Supply	Set the temperature to the lowest temperature setting. If there is sufficient microamp current, but the flame will not stay lit, check for proper polarity of the power supply.
	Ignition Control	If there is sufficient microamp current, and there is proper polarity of the power supply, but the burner will not stay lit, check the reset button for the ignition control. If the above test is okay, replace the ignition control.
NOTE: Flame should be lit at this time.		

Low flame is on but no main flame	Control Transformer	Check for supply voltage to primary of control transformer. If no voltage is present, trace wiring back to EMI filter. If voltage is present, check for 24VAC at transformer secondary. If there is primary voltage, but no secondary voltage, replace control transformer.
	Oven Control	Adjust temperature to maximum setting and check for 3-24 VDC at terminals J2-6 & J2-9 on oven control. If 3-24 VDC is present and unit is not heating, refer to "Modulating Valve" for next check. If 3-24 VDC is not present, proceed.
	Thermocouple Probe	WITH POWER ON AND THERMOCOUPLE LEADS ATTACHED TO THE TEMPERATURE CONTROL BOARD: Measure the D.C. millivolt output of these leads. Refer to thermocouple chart in "Removal and Installation" section of service manual for proper readings. If these readings are not achieved, replace the thermocouple. If these readings are achieved with temperature at maximum setting, replace the oven control.
	Modulating Valve	With temperature at maximum setting, check for 3-24 VDC at the modulating valve. If no voltage is present, trace wiring back to the oven control terminals J2-6 & J2-9. If voltage is present, check the output gas pressure at the pressure tap located on the burner manifold. If voltage is present and gas pressure is not exceeding .6 in. W.C. at the burner manifold, replace modulating valve.
Intermittent heating	Thermal/Overload of Main Fan and Burner Blower Motors	The main fan motors and the burner blower motors are equipped with internal thermal protection and will cease to operate if overheating occurs. As the motors overheat and then cool, this will cause the units to cycle on and off intermittently. Improper ventilation or improper maintenance may cause this. Also, most of the problems listed under "Oven will not heat" can cause intermittent failure.
Conveyor will not run	Power Supply	Check incoming voltage supply at line 1 to neutral. There should be a line voltage reading. If not present, check breakers.
	10 Amp Fuse	Check and/or replace.
	Fuse Holder	Check and/or replace.
	Main Fan Switch	Check continuity between switch terminals.
	Oven Control Transformer	Check for supply voltage to primary of transformer. If no voltage is present, trace wiring back to the main oven switch. If voltage is present, check for 24VAC at transformer secondary. If there is primary voltage but no secondary voltage, replace transformer. If secondary voltage is present, proceed.
	Switch, Conveyor Reversing	Check for continuity between switch terminals. Replace switch as needed.
Conveyor Motor	Check for supply voltage to the motor. If no voltage is present, trace wiring back to the reversing switch. If no	

Conveyor will not run (continued)		voltage at switch, replace conveyor control. If voltage is present, check motor windings for opens or shorts. WITH POWER OFF: Check the motor windings as follows: Grey to Black – 116 ohm approx. Grey to Brown – 116 ohm approx. Brown to Black – 230 ohm approx. If any of the above fail, replace motor.
	Conveyor Motor Capacitor	Check for shorts or grounds. Replace capacitor as needed. WARNING: Capacitor has a stored charge. Discharge before testing!
	Conveyor	Check for any mechanical problems in the conveyor assembly. Check for damaged or torn belting. Check conveyor shaft bearings for damage or excessive wear. Repair or replace conveyor components as needed.
	Oven Control	Check output voltage from oven control to hall effect sensor (sensor is located in conveyor motor). Measure voltage at the motor connector, red wire and yellow wire. Voltage should be approx. 10VDC. If no voltage is present, trace wiring back to the oven control. If there is no voltage output present at the oven control, replace the oven control.
Conveyor runs but no speed control	Motor, Conveyor	If there is voltage supplied to the hall effect sensor, check for frequency output from the hall effect sensor. Measure frequency across the yellow and white wires at the motor connector. Frequency readings should be between 25 – 500 Hz. If these readings are not achieved, replace the conveyor motor. If these readings are achieved, proceed.
	Oven Control	If the hall effect sensor readings are correct but there is no speed indicated on the display, replace the oven control.

REMOVAL, INSTALLATION & ADJUSTMENTS



WARNING: BEFORE REMOVING OR INSTALLING ANY COMPONENT IN THE IMPINGER OVEN, BE SURE TO DISCONNECT ALL ELECTRICAL POWER AND SHUT OFF GAS SUPPLY.

BURNER CONTROL – HONEYWELL – REPLACEMENT – DOMESTIC ONLY WITH POWER OFF:

- A. Remove appropriate control box cover.
- B. Remove wires from control while noting wire number and location for reassembly.
- C. Remove two (2) screws from control and replace.
- D. Reassemble in reverse order and check system operation.

IGNITION CONTROL – REPLACEMENT – INTERNATIONAL ONLY WITH POWER OFF:

- A. Remove appropriate control box cover.
- B. Remove wires from control while noting wire number and location for reassembly.
- C. Remove one (1) mounting screw and remove ignition control from gas valve.
- D. Reassemble in reverse order and check system operation.

BURNER BLOWER MOTOR – REPLACEMENT WITH POWER OFF:

- A. Remove appropriate control box cover.
- B. Unplug motor connector.
- C. Remove three (3) screws from blower tube at burner housing.
- D. Remove air shutter assembly from old motor for installation on new motor assembly.
- E. Reassemble in reverse order and check system operation.

NOTE: CHECK AIR SHUTTER ADJUSTMENT. It should be set at ½ open.

HOT SURFACE IGNITER – REPLACEMENT – DOMESTIC ONLY WITH POWER OFF:

- A. Remove appropriate control box cover.
- B. Disconnect gas line at union.
- C. Remove four (4) nuts from burner orifice bracket.
- D. Remove tube for bypass flame.
- E. Unplug connector at burner housing.
- F. Remove three (3) screws from burner housing end cap and remove hot surface igniter and burner tube assembly.
- G. Replace igniter assembly and reassemble in reverse order.
- H. CAUTION: USE CARE NOT TO DAMAGE NEW IGNITER. ALSO, NEVER TOUCH IGNITER WITH BARE HANDS.

NOTE: Check all gas line fittings for leaks. Make sure connector is seated properly.

IGNITOR SENSOR – REPLACEMENT – INTERNATIONAL ONLY WITH POWER OFF:

- A. Remove appropriate control box cover.
- B. Remove gas valve assembly (see gas valve).
- C. Remove screws from burner tube and pull burner assembly out.
- D. Remove wire connectors from igniter sensor assembly.
- E. Remove screws from mounting bracket and remove assembly.
- F. Reassemble in reverse order and check system operation.

NOTE: After installation, check all gas line fittings for leaks.

CONVEYOR DRIVE MOTOR – REPLACEMENT WITH POWER OFF:

- A. Shut off power at main breaker.
- B. Remove drive chain and drive sprocket from conveyor motor.
- C. Remove control panel top and front cover.
- D. Disconnect motor connector (6 pin connector).
- E. Remove 4 mounting bolts and remove conveyor motor.
- F. Reassemble in reverse order.

REVERSING SWITCH – REPLACEMENT WITH POWER OFF:

- A. Shut power off at main breaker.
- B. Remove control panel top.
- C. Disconnect wiring from reversing switch and mark all wiring for reassembly.
(See schematic diagram for wire numbers.)
- D. Remove mounting nut from reversing switch and remove reversing switch and reversing switch cover.
- E. Reassemble in reverse order.

REVERSING CONVEYOR DIRECTION

- A. Shut off power at oven switch.
- B. Set reversing switch in the other position.
- C. Turn oven “on” and check for proper operation.

BURNER RESET SWITCH – REPLACEMENT – INTERNATIONAL ONLY WITH POWER OFF:

- A. Remove appropriate control box cover.
- B. Disconnect wires from ignition control (see ignition control). Note wire number and location for reassembly.
- C. Pull off black operating knob and remove hex mounting nut.
- D. Reassemble in reverse order.

BURNER ALARM – REPLACEMENT – INTERNATIONAL ONLY WITH POWER OFF:

- A. Remove appropriate control box cover.
- B. Remove 2 wires from alarm. Note wire number and location for reassembly.
- C. Remove retainer cover from alarm and remove assembly from control box.
- D. Reassemble in reverse order and check system operation.

AIR PRESURE SWITCH – REPLACEMENT – INTERNATIONAL ONLY WITH POWER OFF:

- A. Remove appropriate control box cover.
- B. Disconnect wires from switch making note of wire number and location for reinstallation.
- C. Remove air tube from switch assembly.
- D. Remove mounting screws to remove air pressure switch.
- E. Reassemble in reverse order. Make sure air tube is not blocked or misaligned.
To adjust air pressure switch, remove cover from the switch to expose adjusting screw. To increase sensitivity, turn screw counter-clockwise. To decrease sensitivity, turn screw clockwise. Check for proper line voltage switching from N.C. to N.O. as the air pressure switch closes.

FUSEHOLDER – REPLACEMENT WITH POWER OFF:

- A. Remove appropriate control box cover.
- B. Remove two (2) wires, note wire number and location.
- C. Remove mounting nut on back side of fuse holder and push out.
- D. Reinstall in reverse order and check system operation.

BURNER CONTROL GAS VALVE (DUAL VALVE) – REPLACEMENT – DOMESTIC ONLY

WITH POWER OFF:

- A. Remove appropriate control box cover.
 - B. Remove incoming gas line.
 - C. Remove screws from incoming nipple mounting bracket.
 - D. Remove incoming nipple.
 - E. Remove bypass tube assembly.
 - F. Disconnect pipe union.
 - G. Disconnect wiring from control valve (four [4] push-on connectors). Disconnect wiring from modulating valve (2 wires) making note of wire numbers and location for reinstallation.
 - H. Remove both valves. Replace control valve (valves are connected by a ½ inch pipe nipple).
 - I. Reassemble in reverse order and check system operation. Set manifold pressure on gas valve. Pressure should be 3.5 in. W.C. Nat., 10 in. W.C. L.P. on a cool oven heating up on full flame.
- NOTE: INLET GAS PRESSURE MUST BE A MINIMUM OF 7 IN. W.C. NATURAL AND 11 IN. W.C. L.P. After installation, check all gas line fittings for leaks.

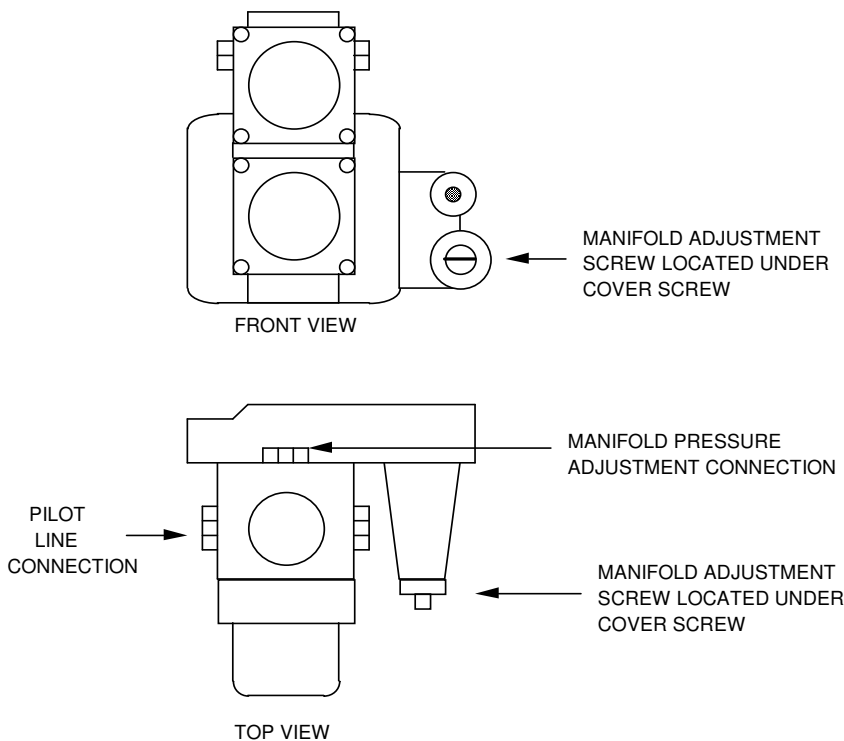

IGNITION CONTROL GAS VALVE (DUAL VALVE) – REPLACEMENT – INTERNATIONAL ONLY

WITH POWER OFF:

- A. Remove appropriate control box cover.
 - B. Remove incoming gas line.
 - C. Remove screws from incoming nipple mounting bracket.
 - D. Remove incoming nipple.
 - E. Remove wiring from ignition control (mounted on gas valve). Mark all wiring for reassembly.
 - F. Remove gas valve and piping assembly.
 - G. Remove piping from gas valve.
 - H. Reassemble in reverse order and check system operation. Set manifold pressure on gas valve. Pressure should be 3.5 in. W.C. Nat., 10 in. W.C. L.P. on a cool oven heating up on full flame.
- NOTE: INLET GAS PRESSURE MUST BE A MINIMUM OF 7 IN. W.C. NATURAL AND 11 IN. W.C. L.P. After installation, check all gas line fittings for leaks.

MODULATING GAS VALVE – REPLACEMENT WITH POWER OFF:

- A. Remove appropriate control box cover.
 - B. Remove incoming gas line.
 - C. Remove screws from incoming nipple mounting bracket.
 - D. Remove incoming nipple.
 - E. Disconnect pipe union.
 - F. Disconnect wiring from control valve. Disconnect wiring from modulating valve (2 wires/screw connections) making note of wire numbers and location for reinstallation.
 - G. Remove both valves. Replace modulating valve (valves are connected by a ½ inch pipe nipple).
 - H. Reassemble in reverse order and check system operation. Verify manifold pressure on control gas valve. Pressure should be 3.5 in. W.C. Nat., 10 in. W.C. L.P. at control (dual) valve on a cool oven heating up on full flame.
 - I. Disconnect 1 wire from modulating valve. Remove cap from valve adjustment screw and adjust manifold pressure to .6 in. W.C. for NAT and .5 in. W.C. for LP. Replace cap and supply wire.
- NOTE: INLET GAS PRESSURE MUST BE A MINIMUM OF 7 IN. W.C. NATURAL AND 11 IN. W.C. L.P. After installation, check all gas line fittings for leaks.

Remove cap and adjust screw until pressure is .6 in. W.C. for NAT and .5 in. W.C. for LP. Turn screw CW to increase pressure and CCW to decrease pressure.

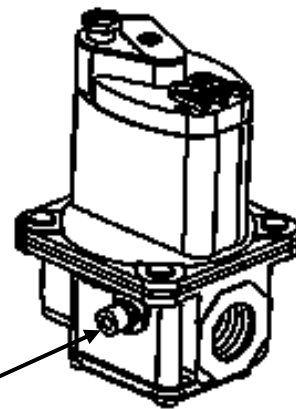

MAIN ORIFICE – REPLACEMENT WITH POWER OFF:

- A. Remove appropriate control box cover.
 - B. Remove bypass tube assembly.
 - C. Remove four (4) nuts from burner orifice bracket.
 - D. Disconnect pipe union.
 - E. Remove assembly and replace main orifice.
 - F. Reassemble in reverse order and check system operation.
- NOTE: Check all gas line fittings for leaks.

ON – OFF SWITCH (POWER) – REPLACEMENT WITH POWER OFF:

- A. Remove control box cover.
 - B. Remove wires from back of switch being sure to note wire number and location.
 - C. Depress spring clips on side of switch and push out.
 - D. Reassemble in reverse order and check system operation.
- NOTE: Make sure switch housing is fully seated in control box housing.

OVEN CONTROL TRANSFORMER – REPLACEMENT

WITH POWER OFF:

- A. Remove control box cover and front panel.
- B. Remove wires from transformer being sure to note color and location of wires for reinstallation.
- C. Remove two (2) screws from transformer base and replace assembly.
- D. Reassemble in reverse order and check system operation.

BURNER CONTROL TRANSFORMER – REPLACEMENT – DOMESTIC ONLY

WITH POWER OFF:

- A. Remove appropriate control box cover.
- B. Remove wires on primary side, note color and location.
- C. Remove wires on secondary side at ignition control (Honeywell) being sure to note color and location.
- D. Remove two (2) screws from transformer base and replace assembly.
- E. Reinstall in reverse order and check system operation.

CAPACITOR, MAIN FAN MOTOR (7.5 MFD/370V) – REPLACEMENT

WITH POWER OFF:

- A. Remove appropriate control box cover.
WARNING: Capacitor has a stored charge. Discharge before handling or testing.
- B. Remove two (2) wires from capacitor being sure to note the wire number and location.
- C. Cut two (2) tyrapts securing capacitor to base and replace.
- D. Reinstall in reverse order and check system for operation.

RELAY – REPLACEMENT

WITH POWER OFF:

- A. Remove control box cover.
- B. Remove wires from relay being sure to note the wire numbers and location for reinstallation.
- C. Remove two (2) screws from relay base and replace relay.
- D. Reassemble in reverse order making sure wire connectors are properly seated.
- E. Check system operation.

THERMOSTAT, COOLING FAN – REPLACEMENT

WITH POWER OFF:

- A. Remove appropriate control box cover.
- B. Remove two (2) wires from thermostat, note wire number and location.
- C. Remove two (2) mounting screws and replace thermostat.
- D. Reassemble in reverse order and check system operation.

OVEN CAVITY HI-LIMIT THERMOSTAT – REPLACEMENT – INTERNATIONAL ONLY

WITH POWER OFF:

- A. Remove appropriate control box cover. Remove motor cover and remove oven back to access high limit thermostat.
- B. Remove wires from thermostat, note wire numbers and location for reinstallation.
- C. Remove screws from bracket and remove thermostat.
- D. Reassemble in reverse order and check system operation.

NOTE: Depress reset button to insure thermostat is set for operation.

COOLING FAN MOTOR – REPLACEMENT

WITH POWER OFF:

- A. Remove appropriate control box cover.
- B. Remove mounting screws.
- C. Unplug electrical connector and remove fan motor assembly.
- D. Reassemble in reverse order and check system operation.

**MAIN FAN MOTOR – REPLACEMENT
WITH POWER OFF:**

- A. Shut off gas supply and remove gas line and manifold lines from back of oven.
- B. Remove screws from motor cover housing and lift off.
- C. Unplug power connector, Thermocouple, and motor connectors.
- D. Remove eight (8) bolts from oven back (4 left, 4 right) and lift out.
- E. Remove one (1) screw from fan hub and slide fan blade off of motor shaft.
- F. Remove eight (8) mounting bolts and remove motor assembly from back assembly.
- G. Remove four (4) mounting nuts, loosen band clamp, and remove motor from mounting assembly.
- H. Reinstall mounting assembly to new motor.
- I. Reassemble in reverse order.

NOTE:

- Make sure motor is centered in back of housing.
 - Position of the fan on the motor shaft will be 2.0" from the top of the oven-back cone to the blade spider assembly on the fan hub (see illustration below).
 - Make sure all connectors are properly seated and making good contact.
 - When reinstalling gas manifold across back of oven, check all fittings for leaks.
- J. Check system operation (allow 30-minute preheat for all checks).

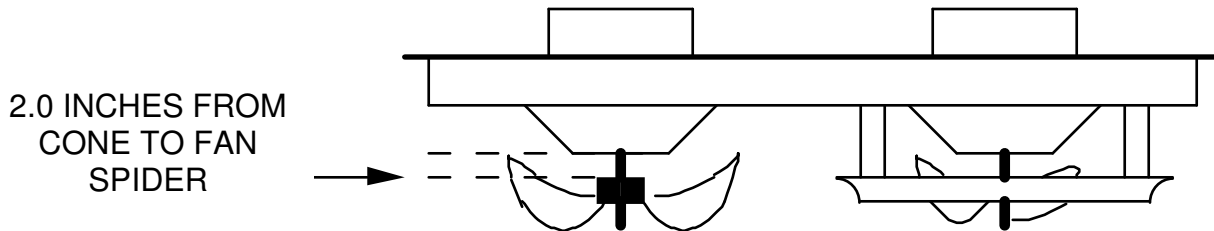

**THERMOCOUPLE (TYPE K) – REPLACEMENT
WITH POWER OFF:**

- A. Remove appropriate control box cover. Remove motor cover and remove oven back to access thermocouple. NOTE: Removal of oven back assembly is required to replace thermocouples.
- B. Thermocouple is connected directly to the oven control board, remove wire connection.
- C. Remove thermocouple from wire form in oven chamber and remove from chamber through control box.
- D. Reassemble in reverse order making sure bulb is placed securely in the wire form in the oven chamber.
- E. Check System operation, recalibrate as needed.

Note: Right hand and left hand thermocouples have different connectors on the wire ends and must be ordered accordingly.

THERMOCOUPLE MEASUREMENT

TEMPERATURE °F (°C)	D.C. MILLIVOLTS (APPX.)
200° (93°)	3.82
250° (121°)	4.96
300° (149°)	6.09
350° (177°)	7.20
400° (204°)	8.31
450° (232°)	9.43
500° (260°)	10.56
550° (288°)	11.70
600° (316°)	12.85

**BEARING, CONVEYOR – REPLACEMENT
WITH POWER OFF:**

- A. Remove conveyor from oven and place on a flat work surface.
- B. Remove connecting links from conveyor belting. See Operator Manual.
- C. Remove conveyor belting from conveyor.
- D. Remove mounting screws that holds bearing assembly to the conveyor frame. Move drive shaft or idle shaft toward center of conveyor and shaft with bearing will slip out of holding bracket.
- E. Replace bearing and reassemble.

**OVEN CONTROL – REPLACEMENT (SEE OVEN CONTROL PROGRAMMING SECTION)
WITH POWER OFF:**

- A. Shut off power at main switch and unplug unit from wall.
- B. Remove appropriate control box cover and front panel.
- C. Remove all wiring connections and mark for reassembly.
- D. Remove oven control by removing 2 nuts and pulling control from the mounting pins.
- E. Before installing new oven control, set voltage jumper (located at the bottom center of the oven control) to the proper voltage (120V / 240V) position. Install the four pushbutton extensions (included with the oven control) by pushing the extensions onto the four set buttons on control.
- F. Reassemble in reverse order and check system operation.

NOTE: Temperature calibration now required. Please see “Oven Control Programming” section.

**CONVEYOR CONTROL – REPLACEMENT
WITH POWER OFF:**

- A. Shut off power at main breaker.
- B. Remove control box cover.
- C. Remove wiring from appropriate conveyor control and mark all wiring for reassembly.
- D. Remove conveyor control by pulling control from the mounting pins. Remove control from oven.
- E. Reassemble in reverse order and set the new control dipswitch settings. See “Oven Control Programming” for more information.
- F. Test system for proper operation.
 - Single Belt or Front Belt – Dip Switch 1 will be ON and 2, 3, and 4 are OFF.
 - Back Belt – (ON SECOND CONVEYOR CONTROL) Dip Switch 2 ON and 1, 3, and 4 are OFF.

OVEN CONTROL – PROGRAMMING

NOTE: All bake times should be within 10 seconds of set bake time. Cavity temperature should be calibrated to within 5°F of set temperature. For temperature calibration, allow oven temperature to stabilize for, at minimum, 30 minutes. Before checking conveyor speed, allow conveyor to run for 10 minutes.

1. **BEFORE APPLYING POWER TO THE OVEN, ENSURE PROPER VOLTAGE JUMPER SETTING FOR 120V OR 240V AND THAT THE 50 HZ / 60 HZ JUMPER SETTING IS CORRECT. JUMPERS ARE LOCATED ON CONVEYOR CONTROL BOARDS.**

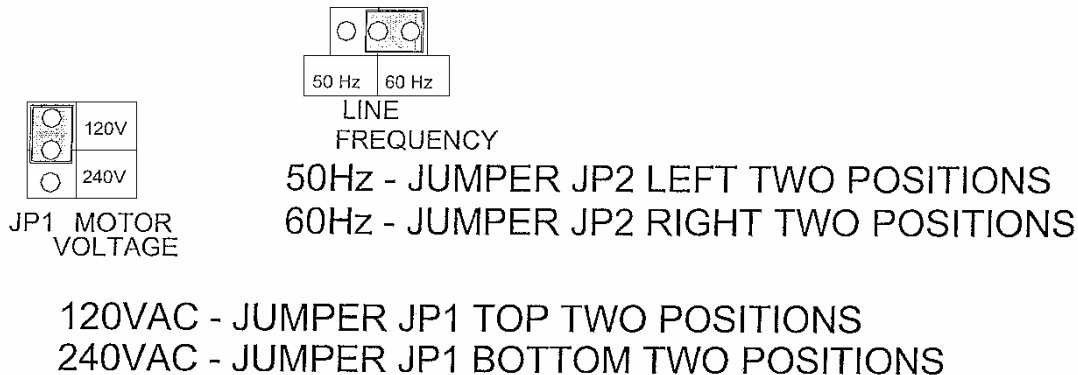

2. **To initialize a new control, hold the two center buttons in then turn unit on. Release buttons.**
 - A. Select the correct oven model number (e.g. 3255 or 3270) by toggling the (+) or (-) buttons. When correct model # is selected, press the TEMP button to store.
 - B. Select the proper belt configuration for this oven by toggling the (+) or (-) buttons. Press the TEMP button to store.
 - C. Allow control sufficient time to update programming. Shut off main fan switch. Initialization of control is now complete.
3. **Set digital control for proper temperature scale °F or °C.**
 - A. Press and hold the 2RH buttons to enter sub-level program. The prompt “**Technicians Only**” will be displayed. Momentarily, a second prompt “**Please Release Buttons**” will be displayed. After releasing the buttons, quickly press the **TIME** button and the **(+)** button to enter the program. After **Sub Program Menu** is displayed, press and release the **TEMP** button. Pressing the **(+)** or **(-)** buttons will toggle choices between °F and °C. After desired scale is selected, allow control to revert back to normal operating mode.
4. **Set bake time and oven temperature – Set Point Menu**
 - A. Press and hold the TIME and TEMP buttons to enter Set Point Menu. Once in Set Point Menu, press TEMP button and adjust temperature using (+) or (-) buttons. Press TIME button while still in Set Point Menu and adjust time using the (+) or (-) buttons. Pressing the TIME or TEMP button will show the respective setting. Once desired settings are programmed, allow control to revert back to normal operating mode.
 - B. While in this mode, continue to press the TIME button to toggle between different conveyors.

5. Adjust temperature offset.

- A. Follow the instructions in Step 3 to enter the Sub Level Program. After Sub Program Menu is displayed, press the TEMP button to access the following temperature features: SCALE (°F or °C), HI TEMP, LOW TEMP, OFFSET (+ or -) MANUFACTURE MODE (Inactive or Active).
NOTE: DO NOT change SCALE after it has been set in step 3A or settings will reset to default values.
- B. To adjust the temperature offset, access the OFFSET display in the Sub Level Program Menu. If cavity temperature is above the set temperature, decrease (- button) the offset value. If cavity temperature is below the set temperature, increase (+ button) the offset value. The amount of offset needed should be the difference between the cavity temperature and the set temperature. Allow oven to reach set temperature and verify cavity temperature. Readjust offset as necessary.
- C. HI TEMP and LOW TEMP are not normally changed unless requested by the customer. Accessing these displays and pressing the (+) or (-) buttons will change indicated setting accordingly.
- D. MANUFACTURE MODE is not normally used and, as such, the feature should be set to “clear”.
- E. While in the Sub Program Menu, pressing the TIME button will access the time features: HI TIME and LOW TIME. These are not normally changed unless requested by the customer. Accessing these displays and pressing the (+) or (-) buttons will change each indicated setting accordingly.

GENERAL VIEW

LETTER	PART NUMBER	DESCRIPTION
A	371013	BAFFLE, INLET & OUTLET
B	370964	PANEL SIDE CONTROL BOX
C	371456	CONTROL BOX TOP, WELDING ASM, LH
D	370963	CONTROL BOX TOP, WELDING ASM, RH
E	7005	TOP, OVEN 3270
F	370965	CHAIN GUARD ASSY
G	371455	FINGER SUPPORT ASSY, 3270
H	370016	NAMEPLATE IMPINGER
I	371474	ACCESS DOOR FRAME ASM, 3270
J	371171	WINDOW RETAINER 304S/S
K	371115	ACCESS DOOR GLASS 3200
L	370966	DOOR KNOB ASSY
M	371140	BRACKET ASSEMBLY LH, ACCESS DOOR SS
N	371459	ACCESS DOOR FRAME ASM
O	371458	ACCESS DOOR GLASS
P	370722	HEX HEAD SCREW
Q	371143	SCR HEX SER FLNG8-32X3/8
R	370725	DOWEL THREAD
S	371141	BRACKET ASSEMBLY RH, ACCESS DOOR SS
T	371457	DOWEL, ACCESS DOOR
U	370976	FINGER HOUSING, TOP ASSY
V		
W	369707	FINGER COVER
X	370977	FINGER HOUSING, BOTTOM ASSY
Y	371068	LEG ASSEMBLY
Z	369030	CASTER

GENERAL VIEW

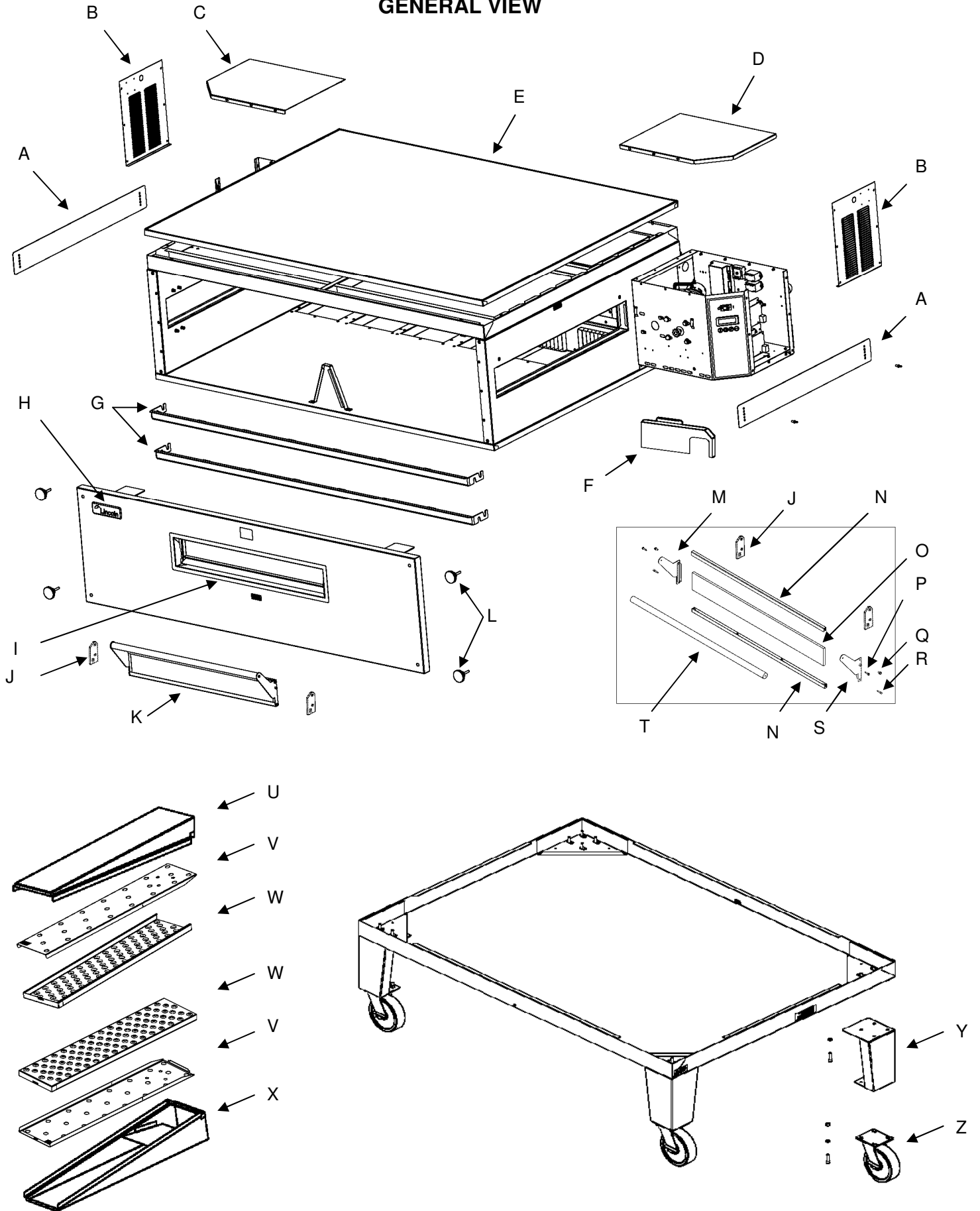

CONTROL BOX, LEFT SIDE - DOMESTIC

LETTER	PART NUMBER	DESCRIPTION
A	370364	LUG GROUND
B	369532	IGNITION CONTROL 2FT
C	369331	FINGER GUARD
D	369124	COOLING FAN
E	369263	NATURAL GAS CONT ASSY
F	371062	VALVE GAS 24VDC 1/2 INCH LH NAT
	371170	VALVE GAS 24VDC 1/2 INCH LH LP
G	369552	IGNITOR HOT SURFACE
H	371008	THERMOCOUPLE TYPE K W/PLUG
I	369366	KIT BURNER BLOWER MTR
J	369401	SHUTTER AIR-ASSY(4071149)
K	390131	SNAP BUSHING HEYCO WP750
L	369568	VENTURI HOT SURFACE NAT
	369938	VENTURI HOT SURFACE LP
M	371460	MAIN ORIFICE .159" NG
	371461	MAIN ORIFICE .098 LP
N	369507	THERMOSTAT BI-METAL
O	371168	CONTROL BOARD MAIN
P	371065	FRONT FACIA, CONTROL BOX
Q	369531	TRANSFORMER GAS
R	371437	VFD DRIVE
S	371438	EMI FILTER
T	371432	DISTANCE SENSOR
U		

CONTROL BOX, LEFT SIDE - DOMESTIC

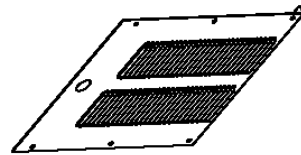
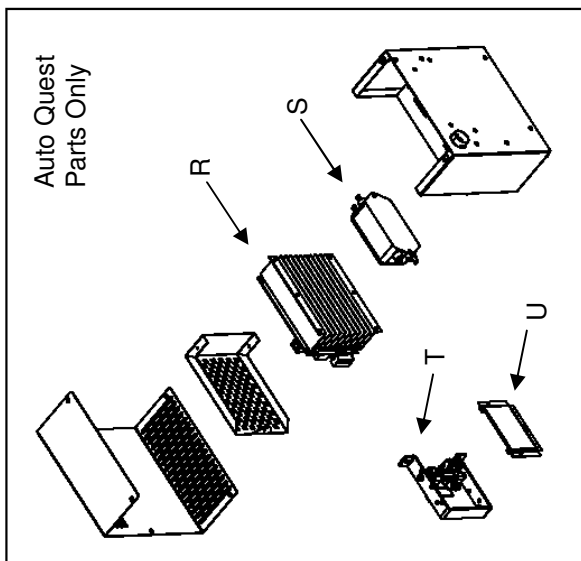
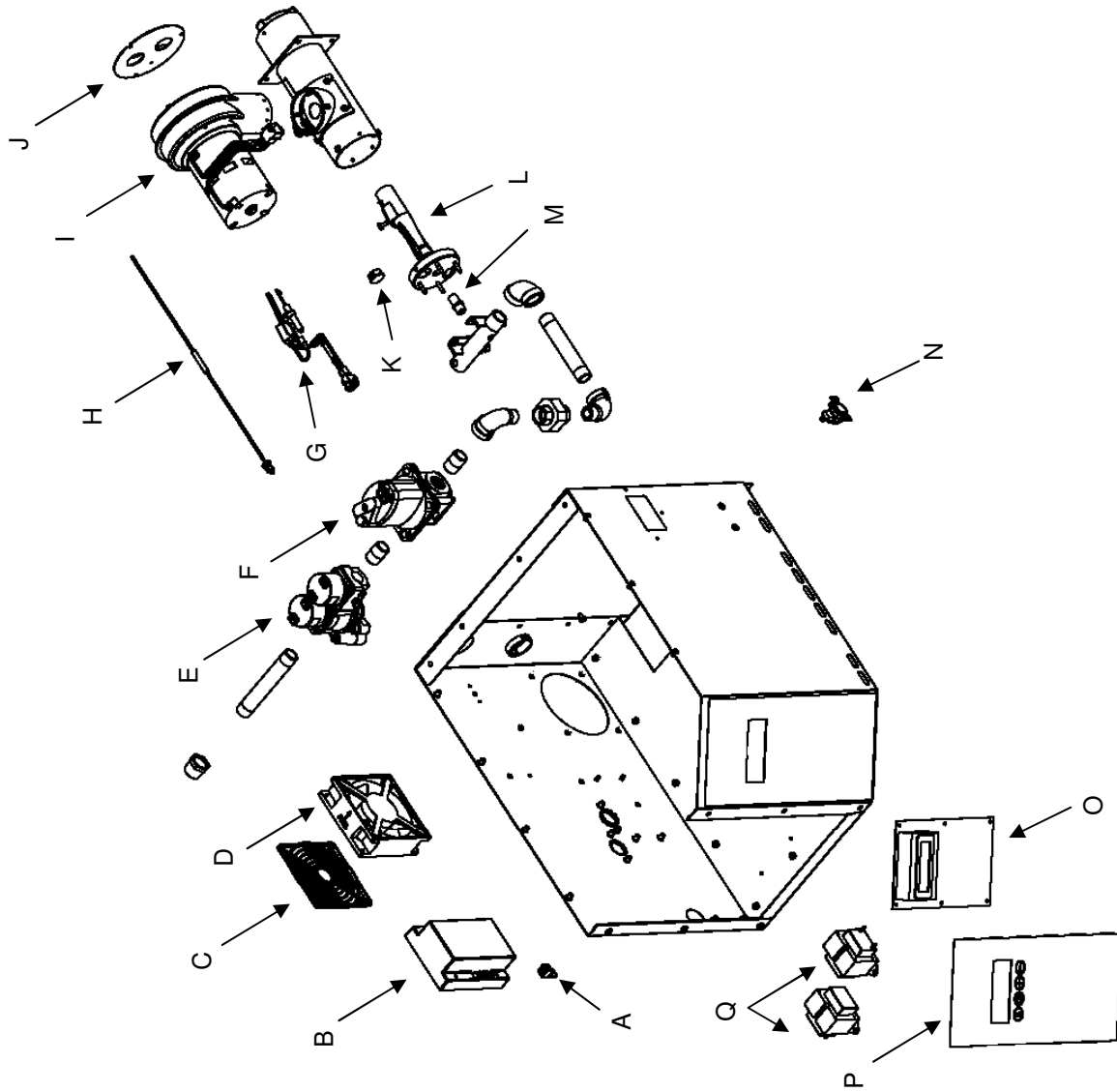

CONTROL BOX, RIGHT SIDE - DOMESTIC

LETTER	PART NUMBER	DESCRIPTION
A	369366	KIT BURNER BLOWER MTR
B	369401	SHUTTER AIR-ASSY(4071149)
C	371008	THERMOCOUPLE TYPE K W/
D	369552	IGNITOR HOT SURFACE
E	369568	VENTURI HOT SURFACE NAT
	369938	VENTURI HOT SURFACE LP
F	371460	MAIN ORIFICE .159" NG
	371461	MAIN ORIFICE .098 LP
G	390131	SNAP BUSHING HEYCO WP750
H	371063	VALVE GAS 24VDC 1/2 INCH RH NAT
	371169	VALVE GAS 24VDC 1/2 INCH RH LP
I	369263	NATURAL GAS CONT ASSY
J	369124	COOLING FAN
K	369331	FINGER GUARD
L	369532	IGNITION CONTROL 2FT
M	370359	SWITCH CNVYR REVRS ASSY
N	369508	TIMER 20 MIN
O	370352	CAPACITOR 115V DIGITAL
P	369523	MOTOR RELAY
Q	390090	CONVEYOR CONTROL
R	369130	FUSE 15A
S	369129	FUSE HOLDER 15A
T	369531	TRANSFORMER GAS
U	369805	SWITCH ROCKER LIGHTED
V	371168	CONTROL BOARD MAIN
W	371061	FRONT FACIA, CONTROL BOX
X	369507	THERMOSTAT BI-METAL
Y	370983	115V 3255 MOTOR ASSY
Z	371415	SPROCKET 10T CHAIN
AA	371437	VFD DRIVE
AB	371438	EMI FILTER
AC	371432	DISTANCE SENSOR
AD	371433	SENSOR BOARD
AE	371436	RELAY,DPDT,24VAC COIL
AF	371439	ESM LIGHT
AG	371434	EMULATOR BOARD

CONTROL BOX, RIGHT SIDE - DOMESTIC

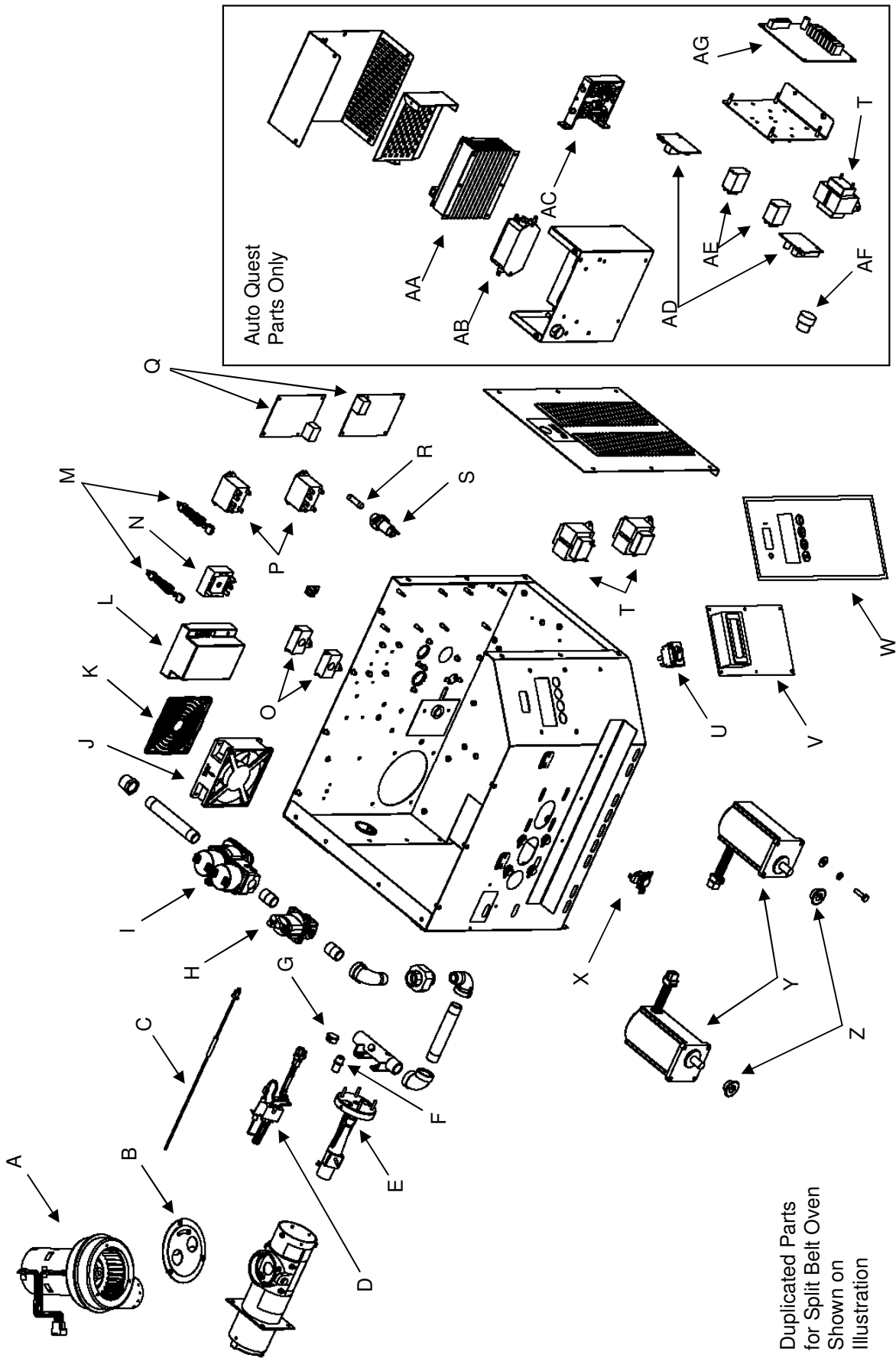

Duplicated Parts
for Split Belt Oven
Shown on
Illustration

CONTROL BOX, LEFT SIDE - INTERNATIONAL

LETTER	PART NUMBER	DESCRIPTION
A	370401	IGNITOR PLUG-IN MODULE
B	370400	VALVE VK4115 A 1000
C	371062	VALVE GAS 24VDC 1/2 INCH LH NAT
	371170	VALVE GAS 24VDC 1/2 INCH LH LP
D	369689	PRESSURE TAP FITTING
E	369757	ORIFICE LOW PRO NAT
	369758	ORIFICE LOW PRO LP
F	369937	VENTURI SPARK NAT
	369773	VENTURI SPARK LP
G	390131	SNAP BUSHING HEYCO WP750
H	370397	SPARK IGNITOR ASSY
I	369401	SHUTTER AIR-ASSY(4071149)
J	369589	MOTOR BLOWER
K	369579	ALARM 250V SOLID STAT
L	370673	AIRSWITCH PS100 GOLDTEC
M	369368	TSTAT HILIM B&C GERM
N	371350	AIR SENSOR TUBE
O	369771	SWITCH PUSH BUTTON
P	369331	FINGER GUARD
Q	369378	MOTOR FAN 230VAC
R	369507	THERMOSTAT BI-METAL
S	369105	CAPACITOR TERMINAL CVR
T	369192	CAPACITOR
U	371345	AIR SENSOR TUBE
V	371466	EMERGENCY STOP PUSH BUTTON
W	370241	TRANSFORMER ASSY 9901082
X	371168	CONTROL BOARD MAIN
Y		FRONT FASCIA, CONTROL BOX

CONTROL BOX, LEFT SIDE - INTERNATIONAL

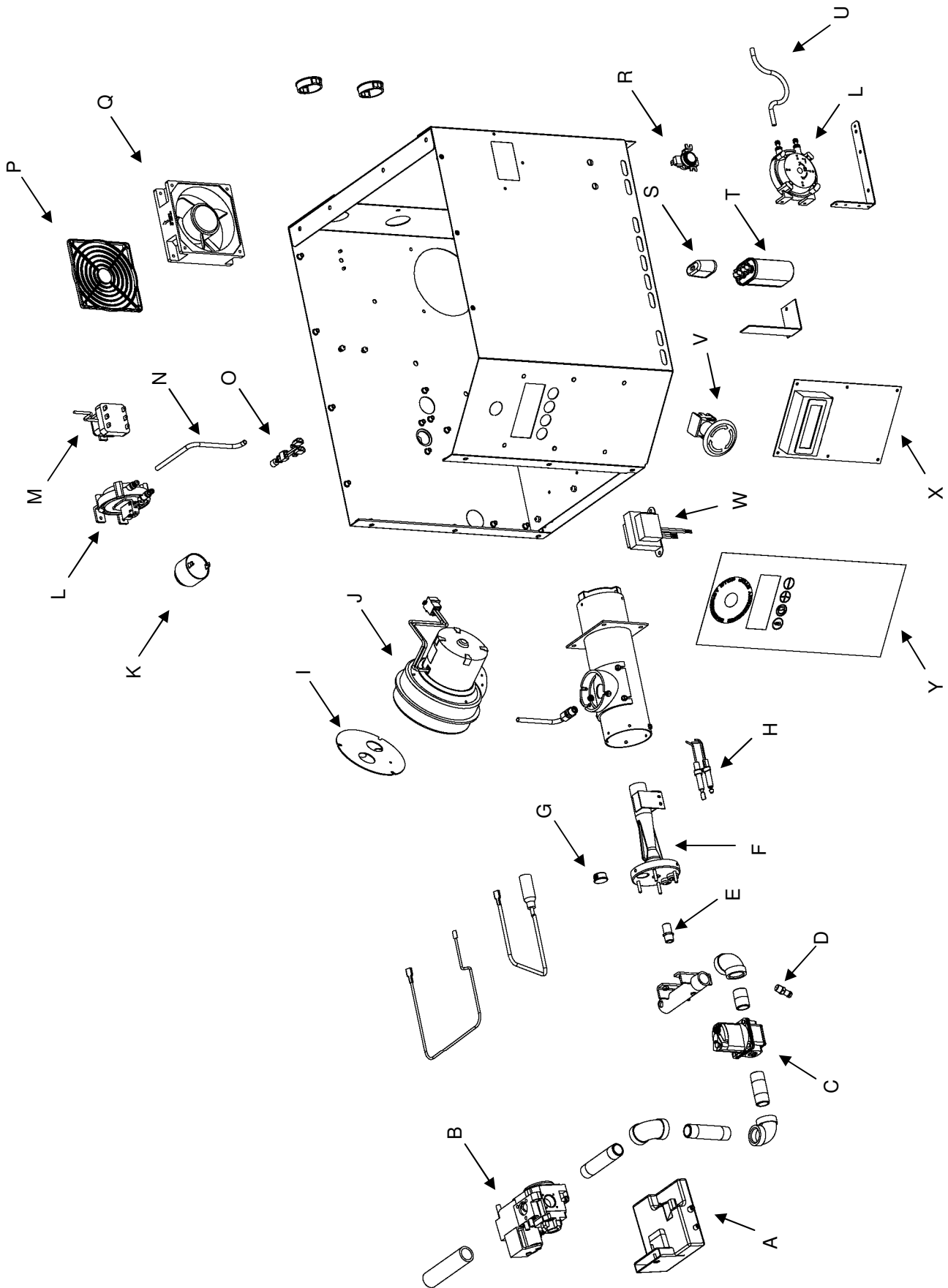

CONTROL BOX, RIGHT SIDE – INTERNATIONAL

LETTER	PART NUMBER	DESCRIPTION
A	370117	TERMINAL BLOCK 5POLE
B	369368	TSTAT HILIM B&C GERM
C	369331	FINGER GUARD
D	370673	AIRSWITCH PS100 GOLDTEC
E	370466	TIMER COOL DOWN 30MIN
F	369422	RELAY DPST 240V
G	390090	CONVEYOR CONTROL
H	369378	MOTOR FAN 230VAC
I	371350	TUBE AIR SENSOR
J	369771	SWITCH PUSH BUTTON
K	370359	SWITCH CNVYR REVRS ASSY
L	370342	FUSE HOLDER HTB-361
M	369014	FUSE 10 AMP
N	369579	ALARM 250V SOLID STAT
O	370387	FILTER EMI
P	369589	MOTOR BLOWER
Q	369401	SHUTTER AIR-ASSY(4071149)
R	370674	SURGE PROTECTOR
S	370360	CAPACITOR 230V DIGITAL
T	370184	FILTER RFI
U	369125	TERMINAL BLOCK
V	370397	SPARK IGNITOR ASSY
W	390131	SNAP BUSHING HEYCO WP750
X	369937	VENTURI SPARK NAT
	369773	VENTURI SPARK LP
Y	369757	ORIFICE LOW PRO NAT
	369758	ORIFICE LOW PRO LP
Z	369689	PRESSURE TAP FITTING
AA	371063	VALVE GAS 24VDC 1/2 INCH RH NAT
	371169	VALVE GAS 24VDC 1/2 INCH RH LP
AB	370400	VALVE VK4115 A 1000
AC	370401	IGNITOR PLUG-IN MODULE
AD	369432	SWITCH ON-OFF
AE	371168	CONTROL BOARD MAIN
AF	371061	FRONT FACIA, CONTROL BOX
AG	371211	230V 3255/3270 CE MOTOR ASSY
AH	370241	TRANSFORMER ASSY 9901082
AI	369192	CAPACITOR
AJ	369105	CAPACITOR TERMINAL CVR
AK	371415	SPROCKET 10T CHAIN
AL	369507	THERMOSTAT BI-METAL
AM	371345	AIR SENSOR TUBE

CONTROL BOX, RIGHT SIDE - INTERNATIONAL

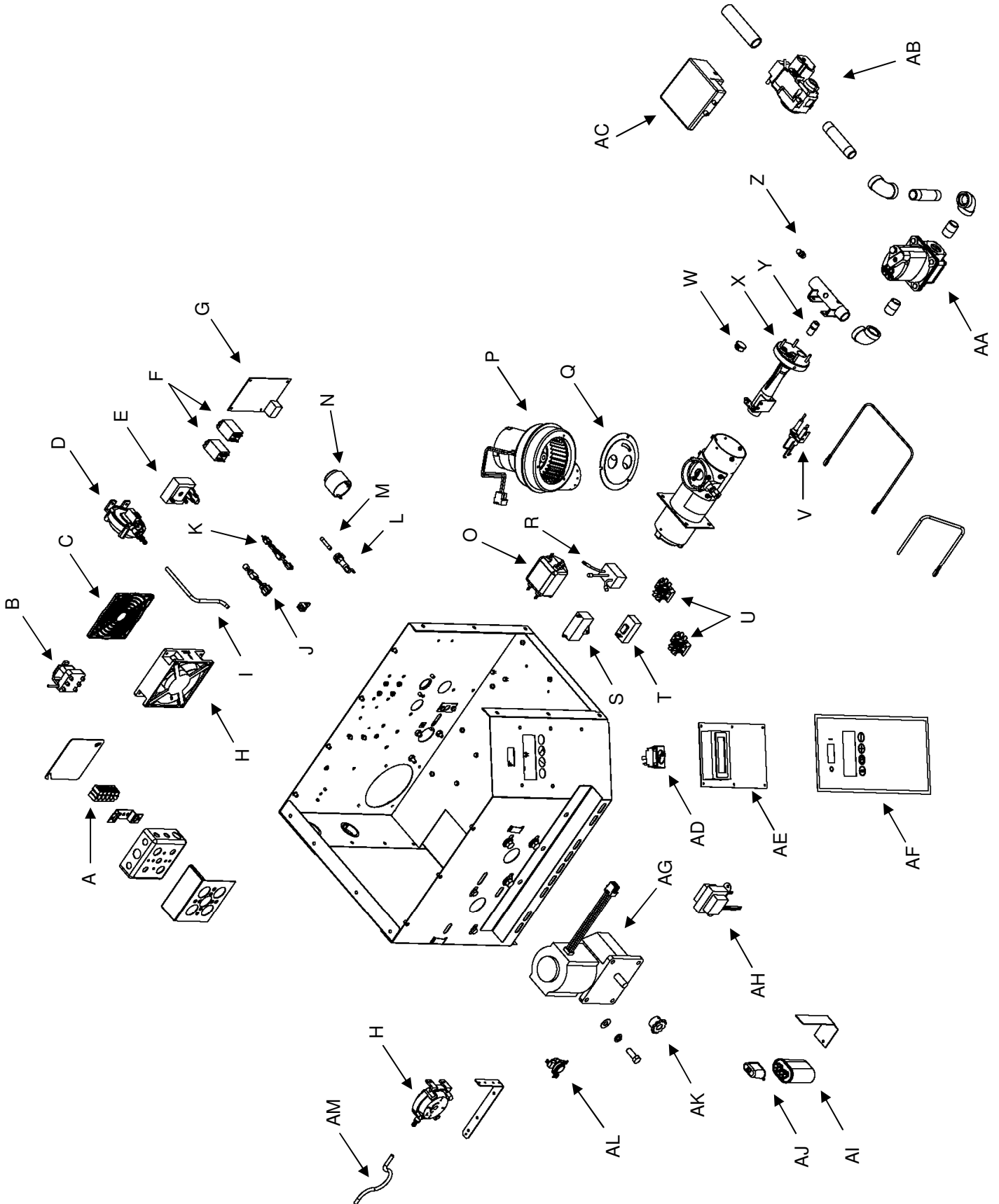

REAR WALL MOTOR ASSEMBLY

LETTER	PART NUMBER	DESCRIPTION
A	371462	SHROUD FAN 3270
B	369213	FAN ASSY 3FT
C	369777	ROD STAND-OFF L/P
D	371473	REAR WALL ASM
E	369215	MOTOR SUPPORT ASSY
F	369800	MOTOR BLOWER ADV 3' 60HZ 120V
	369214	MOTOR 50HZ 230V
G	369033	CLAMP MOTOR
H	357003	CLAMP HOSE
I	369192	CAPACITOR
J	369105	CAPACITOR TERMINAL CVR
K	371463	FAN COVER, 3270
L	371342	RACEWAY
M	371362	3270-CE MANIFOLD ASSY KIT

REAR WALL MOTOR ASSEMBLY

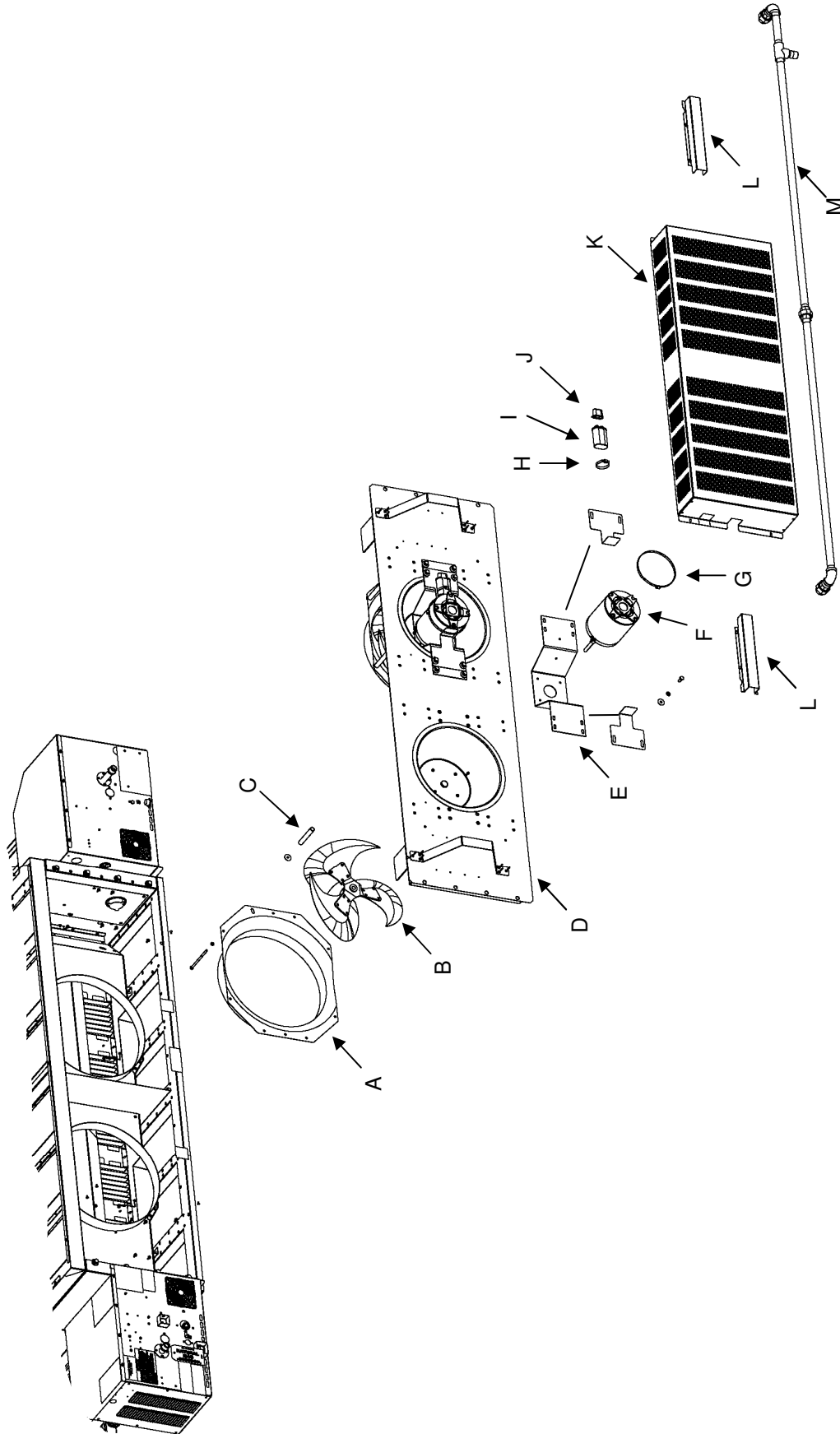

CONVEYOR, FULL BELT

LETTER	PART NUMBER	DESCRIPTION
A	390119	ZERO STOP SB 32
B	369002	CONVEYOR TENSION KNOB
C	371001	TENSIONER FULL BELT ASSEMBLY
D	370990	BEARING BLOCK ASSY 3255
E	371004	SHAFT DRIVE END 32
F	371464	CONVEYOR FRAME WELD FULL BELT
G	371006	CONVEYOR BUSHING ASSY
H	369039	GEAR DRIVE BLANK
I	369038	GEAR DRIVE NOTCHED
J	370994	SHAFT IDLE END 32
K	369161	ROLLER CHAIN SPROCKET
L	371003	ROLLER CHAIN, FULL BELT
M		
N		
O	371002	SPLICE CLIP, FULL BELT
P	371007	BELT FULL 3262

CONVEYOR, FULL BELT

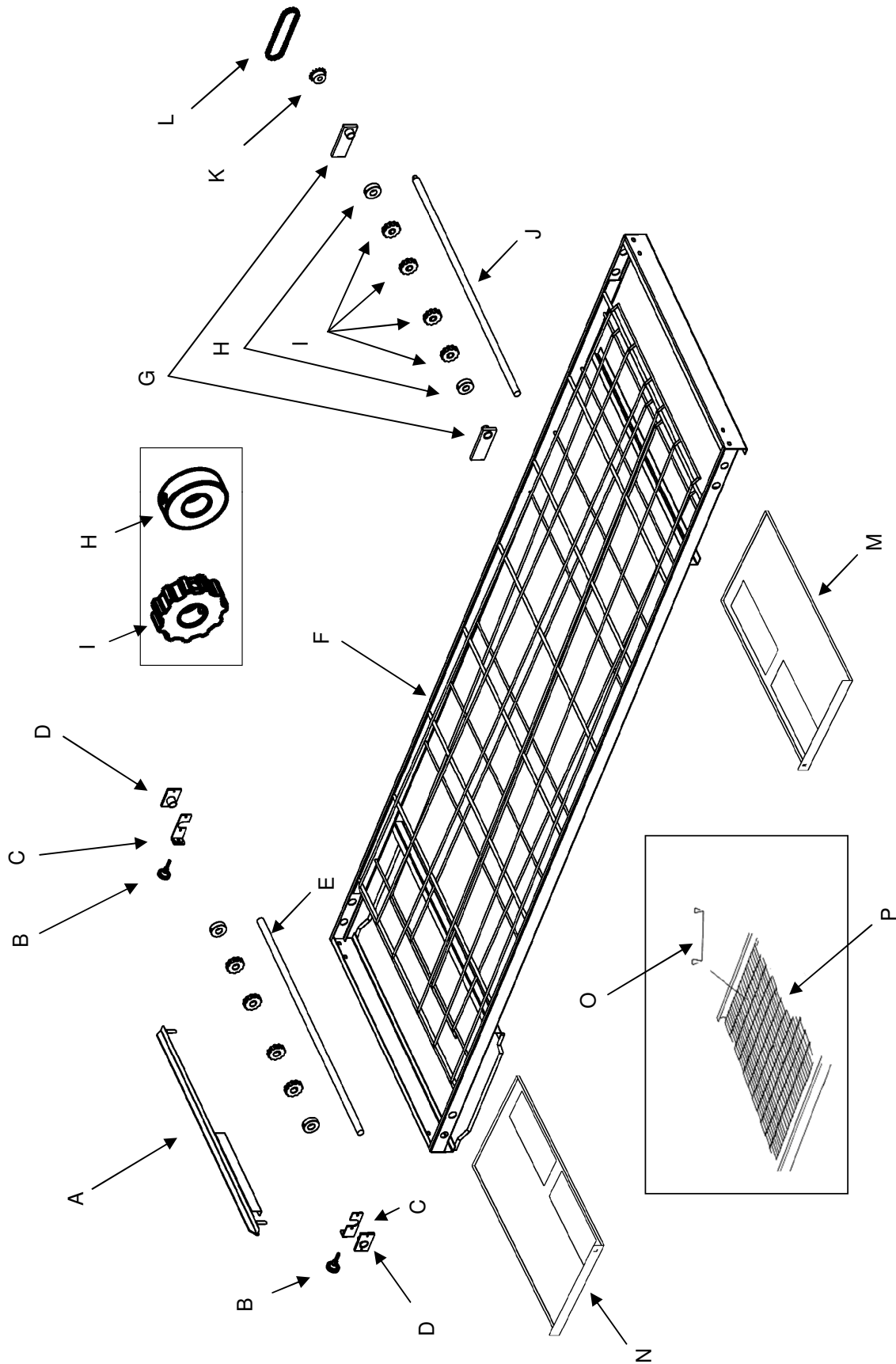

CONVEYOR, SPLIT BELT

LETTER	PART NUMBER	DESCRIPTION
A	370990	BEARING BLOCK ASSY 3255
B	370988	TENSIONER SPLIT OUTER ASSY
C	371337	TENSIONER SPLIT INNER ASSY
D	369002	CONVEYOR TENSION KNOB
E	369038	GEAR DRIVE NOTCHED
F	369039	GEAR DRIVE BLANK
G	370994	SHAFT IDLE END 32
H		
I	390119	ZERO STOP SB 32
J	370996	CONVEYOR BUSHING ASSY
K	371204	SPROCKET 1/2 BORE 23N 3255/3270 SPLIT
L	370998	DRIVE SHAFT OUTER SPLIT BELT
M	370995	DRIVE SHAFT INNER SPLIT BELT
N	5508	VENTED CRUMB TRAY RIGHT
O	5507	VENTED CRUMB TRAY LEFT
P	370985	SPLICE CLIP SB
Q		

CONVEYOR, SPLIT BELT

