

SERVICE MANUAL

(DOMESTIC & INTERNATIONAL)

IMPINGER CONVEYOR OVENS

LOW PROFILE - 1600 SERIES



Lincoln Foodservice Products, Inc.
1111 North Hadley Road
P.O. Box 1229
Fort Wayne, Indiana 46801-1229

Phone: (800) 374-3004 • Fax: (260) 436-0735

Technical Service Hot Line
(800) 678-9511

www.lincolnfp.com

TABLE OF CONTENTS

TABLE OF CONTENTS.....	2
SEQUENCE OF OPERATIONS 1600 / 1601 / 1652.....	3
SEQUENCE OF OPERATIONS 1622 / 1623.....	4
SEQUENCE OF OPERATIONS / 1628 / 1629.....	5
SEQUENCE OF OPERATIONS / 1646, 1647, 1650, 1651.....	7
SCHEMATIC / 1600, 1601, 1652.....	9
SCHEMATIC / 1622, 1623.....	10
SCHEMATIC / 1628, 1629.....	11
SCHEMATIC / 1646, 1647, 1650, 1651.....	12
TROUBLESHOOTING GAS OVENS.....	13
TROUBLESHOOTING / 1622, 1623, 1628, 1629.....	20
TROUBLESHOOTING / 1646, 1647, 1650, 1651.....	26
REMOVAL, INSTALLATION & ADJUSTMENTS.....	32
PARTS / GENERAL - 1600 SERIES.....	48
BLOW UP / GENERAL – 1600 SERIES.....	49
PARTS / CONTROL BOX, RIGHT- 1600 - 1601 - 1652.....	50
BLOW UP / CONTROL BOX RIGHT – 1600, 1601, 1652.....	51
PARTS / CONTROL BOX, LEFT - 1600 - 1601 - 1652.....	52
BLOW UP / CONTROL BOX LEFT – 1600, 1601, 1652.....	53
PARTS / CONTROL BOX, RIGHT –1622,1623,1628,1629.....	54
BLOW UP / CONTROL BOX RIGHT – 1622,1623,1628,1629.....	55
PARTS / CONTROL BOX, LEFT 1622,1623,1628,1629.....	56
BLOW UP / CONTROL BOX LEFT – 1622, 1623, 1628, 1629.....	57
PARTS / CONTROL BOX RIGHT – 1646, 1647, 1650, 1651.....	58
BLOW UP / CONTROL BOX RIGHT – 1646,1647,1650,1651.....	59
PARTS / CONTROL BOX LEFT – 1646, 1647, 1650, 1651.....	60
BLOW UP / CONTROL BOX LEFT – 1646,1647,1650,1651.....	61
PARTS / BACK - 1600 SERIES.....	62
BLOW UP / BACK – 1600 SERIES.....	63
PARTS / CONVEYOR - 1600 SERIES.....	64
BLOW UP / CONVEYOR – 1600 SERIES.....	65

SEQUENCE OF OPERATIONS 1600 / 1601 / 1652

MODEL 1600 / 120 VAC / 60 HZ / NATURAL GAS

MODEL 1601 / 120 VAC / 60 HZ / L.P. GAS

MODEL 1652 / 120 VAC / 60 HZ / TOWN GAS

POWER SUPPLY	<p>Electrical power to be supplied to the oven by a three conductor cordset. Voltage from the black conductor to the white conductor is 120 VAC.</p> <p>White conductor is Neutral. Green conductor is Ground.</p>
CONTROL BOX AUTO COOL DOWN	<p>When the temperature in either one of the Control Boxes reaches 120°F ± 3°F (49°C ± 1.7°C), the Cooling Fan Thermostats will switch power to the Cooling Fans. The thermostats will interrupt power to the Cooling Fans when the temperature falls to 100°F ± 3°F (37°C ± 1.7°C).</p>
MAIN FAN CIRCUIT	<p>120 VAC is permanently supplied to the normally open contacts of the Oven Power Relay, to terminal #1 of the 20-Minute Time Delay Module, the normally open contacts of the Fan Relay and to the (2) normally open Cooling Fan Thermostats. Closing the normally open Power Switch supplies 120 VAC to the coil of the Oven Power Relay. These normally open contacts now close, enabling the 20-Minute Time Delay Module. The 20 Minute Time Delay Module supplies 120 VAC to the Oven Fan Relay, these normally open contacts now close, supplying 120 VAC, through a 10 Amp fuse, to the (2) Main Fan Motors and, through a 3 Amp fuse, to the (2) Control Box Cooling Fans.</p>
BURNER CIRCUIT	<p>Closing the Oven Power Relay energizes the coil of the Burner Relay. The (2) normally open contacts now close supplying 120 VAC to the (2) burner systems.</p> <p>NOTE: This oven utilizes (2) complete Burner/Temp. Control Systems. The sequence of operations is the same for each system. 120 VAC is supplied, through the Centrifugal Switch of the Main Fan Motor (this switch closes when the Main Fan reaches approximately 1600 R.P.M.) through the 10 Amp Fuse, to the Ignition Control, the Electronic Temperature Control, and to the Burner Blower Motor. As this Blower reaches approximately 1600 R.P.M., its internal centrifugal switch will close, supplying 120 VAC through the cooling fan sail switch to the Burner Transformer.</p> <p>NOTE: The Cooling Fan Sail Switch is mounted in front of the cooling fan and is activated by the air flow of the Cooling Fan. The secondary of the Transformer supplies 24 VAC to the Ignition Control. The Ignition Control operates on both 24 VAC and 120 VAC. When the control is energized by 24 VAC, 120 VAC is switched to the Hot Surface Ignitor for 45 seconds for Hot Surface Igniter warm up 24 VAC is now switched to the Gas Valves which open. Ignitor glows red, and ignition should now occur. The red Indicator Light is also now energized. If ignition does not occur within 6 seconds, the control will lock out. To retry after lockout, turn off the burner switch, wait 45 seconds, and then turn the switch back on.</p>
TEMPERATURE CONTROL	<p>When the Centrifugal Switch of the Burner Blower Motor closes, power is applied to the Temperature Control. The 2.5 K ohm Temperature Pot is adjusted to desired temperature. The thermocouple will provide varying millivolts to the Temperature Controller. The Temperature Controller supplies 120 VAC to Temperature Regulation Valve at intermittent intervals to maintain desired temperature.</p>
CONVEYOR DRIVE	<p>Closing the Power Switch supplies 120 VAC, through the contact of the Oven Power Relay, to the primary of the (2) Time/Temp. Transformers. The secondary output of the Transformers, 12.5 to 15 VAC with a center tap, is supplied to terminals 1, 2, and 3 of the Time/Temp. Display. The Display works on a balanced input, and center tap voltage to each leg must be 1/2 the total reading.</p>
TIME/TEMP DISPLAY	<p>The speed side of the Time/Temp. Display is supplied, by the Conveyor Control, with the frequency of the pulses to the Conveyor Motor. This frequency is converted by the Time/ Temp. Display into a read out of minutes and seconds.</p>
NOTE	<p>The Conveyor Control uses a sensor and magnet, mounted on the Conveyor Motor, that senses when the motor is turning. If the motor is not turning, the Time/Temp. Display will show "--:--" in the window.</p> <p>The temperature portion of the display uses a Thermistor Probe to sense oven temperature. The Thermistor outputs a resistance proportional to oven temperature. This resistance is then converted by the Display into a temperature reading.</p>

	<p>OR: The temperature portion of the display uses a "J" type thermocouple to measure oven temperature. The thermocouple generates D.C. millivolts proportional to oven temperature. This millivolt reading is then converted by the display into a temperature reading.</p> <p>The oven utilizes (2) Temperature Display systems, one each for the left and right sides of the cooking chamber.</p>
--	--

SEQUENCE OF OPERATIONS 1622 / 1623

MODEL 1622 / 120/208 VAC./3 PHASE 60 HZ
MODEL 1623 / 120/240 VAC / 3 PHASE. / 60 H

POWER SUPPLY	<p>Electrical power to be supplied to the oven by a five conductor service.</p> <p>Voltage from the black conductor to the white conductor is 120 VAC.</p> <p style="padding-left: 40px;">Black conductor is Hot. Red conductor is Hot. Orange conductor is Hot. White conductor is Dedicated Neutral. Green conductor is Ground.</p>
CONTROL BOX AUTO COOL DOWN	<p>When the temperature in either one of the Control Boxes reach 120°F± 3°F (49°C± 1.7°C), the Cooling Fan Thermostats will switch power to the Cooling Fans. The thermostats will interrupt power to the Cooling Fans when the temperature falls to 100°F± 3°F (37°C ± 1.7°C).</p>
MAIN FAN CIRCUIT	<p>Electrical power is permanently supplied through (6)- 50 A. fuses to the normally open contacts of the mercury contactors. Power is also supplied, through a 10A fuse, to the Oven Power Switch , through a 3A fuse to a normally open contact of the Oven Fan Relay, term. # 1 of the 20 minute Time Delay Module and the (2) normally open Cooling Fan Thermostats. Power is also supplied to a normally open contact of the the Oven Power Relay. Closing the normally open Oven Power Switch supplies 120 VAC to the coil of the Oven Power Relay. These normally open contacts now close, enabling the 20 minute Time Delay Module. The 20 minute Time Delay Module supplies 120 VAC to the coil of the oven fan relay, these normally open contacts now close, supplying 120 VAC to the (2) Main Fans and to the (2) Control Box Cooling Fans.</p>
HEAT CIRCUIT	<p>Closing the Oven Power Relay, supplies 120 VAC, through a 3 A fuse, to the (2) heat systems.</p> <p>NOTE: This oven utilizes (2) complete Heat/Temp control systems. The sequence of operations is the same for each system. 120 VAC is supplied, through the Centrifugal Switch of the Main Fan Motor, (This switch closes when the Main Fan reaches approximately 1600 R.P.M.) through the normally closed High Limit Thermostat (manually re-settable which opens at 660° F, 350°C) through the normally open Cooling Fan Sail Switch to the Electronic Temperature Control and the Heat Indicator Light.</p> <p>NOTE: The Cooling Fan Sail Switch is mounted in front of the Cooling Fan and is activated by the air flow of the Cooling Fan.</p>
TEMPERATURE CONTROL	<p>When the Cooling Fan Sail Switch closes, 120 VAC is supplied to the Temperature Control. The Temperature Control Potentiometer (2.5K ohm) is adjusted to desired temperature. The Thermocouple will provide varying millivolts to the Temperature Controller. The Temperature Controller supplies 120 VAC to the contactor coil at intermittent intervals, (closing the Contactor and supplying 208 or 240 VAC to the Heating Elements) to maintain desired temperature.</p>
CONVEYOR DRIVE	<p>Closing the Oven Power Switch supplies 120 VAC, through the contact of the Oven Power Relay, to the normally open Conveyor Switch. Closing the Conveyor Switch supplies 120 VAC, through a 3 Amp Fuse, to the primary of the Conveyor Control Transformer. The secondary of this Transformer supplies 10 VAC and 29 VAC to the</p>

	Conveyor Control. The Conveyor Control supplies voltage pulses to the Conveyor Motor. The ConveyorControl Potentiometer varies the frequency of these pulses. The motor speed will increase or decrease, as the frequency of the pulses increase or decrease respectively.
TIME/TEMP DISPLAY	Closing the Oven Power Switch supplies 120 VAC, through the contact of the Oven Power Relay, to the primary of the (2) Time/TempTransformers. The secondary output of the Transformers, 12.5 to 15 VAC with a center tap, is supplied to terminals 1, 2, and 3 of the Time/Temp. Display. The display works on a balanced input, and center tap voltage to each leg must be 1/2 the total reading. The speed side of the Time/Temp. Display is supplied, by the Conveyor Control, with the frequency of the pulses to the Conveyor Motor. This frequency is converted by the Time/Temp. Display into a read out of minutes and seconds.
NOTE:	<p>The Conveyor Control uses a Sensor and Magnet, mounted on the Conveyor Motor, that senses when the motor is turning. If the motor is not turning, the Time/Temp. Display will show "- - : -" in the window.</p> <p>The temperature portion of the display uses a Thermistor Probe to sense oven temperature. The Thermistor outputs a resistance proportional to oven temperature. This resistance is then converted by the Display into a temperature reading.</p> <p style="text-align: center;">OR:</p> <p>The temperature portion of the display uses a "J" type thermocouple to measure oven temperature. The thermocouple generates D.C. millivolts proportional to oven temperature. This millivolt reading is then converted by the display into a temperature reading. The oven utilizes (2) Temperature Display systems, one each for the left and right sides of the cooking chamber.</p>

SEQUENCE OF OPERATIONS / 1628 / 1629

MODEL 1628 / 380/220 VAC / 3 PHASE / 50 HZ
MODEL 1629 / 415/240 VAC / 3 PHASE / 50 HZ

POWER SUPPLY	Electrical power to be supplied to the oven by a five conductor service. Brown conductor is hot. Black conductor is hot. Black conductor is hot. Blue conductor is neutral. Green/yellow conductor is ground.
CONTROL BOX AUTO COOL DOWN	When the temperature in either one of the Control Boxes reaches 120°F ± 3°F (49°C ± 1.7°C), the Cooling Fan Thermostats will switch power to the Cooling Fans. The thermostats will interrupt power to the Cooling Fans when the temperature falls to 100°F ± 3°F (37°C ± 1.7°C).
MAIN FAN CIRCUIT	Line voltage is permanently supplied through (6) 50 A. fuses, to the normally open merco contactors, through a 10A fuse, to a normally open contact of the Oven Fan Relay, through a 3A fuse to the primary of the circuit step down transformer. (The transformer steps the voltage down to 120 VAC for the control circuit). 120 VAC is supplied to a normally open contact of the Oven Fan Relay, the (2) normally open cooling thermostats, a normally open contact of the Oven Power Relay, terminal #1 of the 20 minute Time Delay Module and to the normally open Power Switch. Power Switch supplies 120 VAC to the Oven Power Relay, its contacts now close, enabling the 20 minute Time Delay Module. The 20 -minute Time Delay Module supplies 120 VAC to the Oven Fan Relay, its contacts now close. supplying line voltage to the (2) Main Fan Motors and 120 VAC to the (2) cooling fans. 120 VAC is also supplied to the (2) Time/Temp Transformers, the (2) electronic temperature controls and to the normally

	open Conveyor Switch.
HEAT CIRCUIT	<p>Closing the Oven Power Relay supplies 120 VAC, through a 3A fuse, to the (2) Heat/Temp Control systems</p> <p>NOTE: This oven utilizes (2) complete Heat/Temperature Control systems. The sequencing operations is the same for both systems, 120 VAC is supplied through a normally open Air Pressure Switch, (closed by air pressure Main Fan), through the normally closed Hi-limit Thermostat, (manually re-settable opens at 350°C (662°F)) through the Sail Switch to the Electronic Temperature Control Board.</p> <p>NOTE: The Cooling Fan Sail Switch is mounted in front of the Cooling Fan and is activated by the air flow of the Cooling Fan</p>
TEMPERATURE CONTROL	<p>When the Sail Switch closes, power is applied to the Electronic Temperature Control. The 2.5 K Ohm Temperature Pot. is adjusted to the desired temperature. The Thermocouple will provide varying millivolts to the Temperature Controller. The Temperature Controller supplies 120 VAC to the contactor coil at intermittent intervals (closing the contactor and supplying 220 or 240 VAC to the heating elements) to maintain desired temperature</p>
CONVEYOR DRIVE	<p>Closing the Oven Power Switch supplies 120 VAC, through the contact of the Oven Power Relay, to the normally open Conveyor Switch. Closing the Conveyor Switch supplies 120 VAC, through a 3 Amp Fuse, to the primary of the Conveyor Control Transformer. The secondary of this Transformer supplies 10 VAC and 29 VAC to the Conveyor Control. The conveyor control supplies voltage pulses to the Conveyor Motor. The Conveyor Control Potentiometer varies the frequency of these pulses. The motor speed will increase or decrease, as the frequency of the pulses increase or decrease respectively.</p>
TIME/TEMP DISPLAY	<p>Closing the Oven Power Switch supplies 120 VAC to the primaries of the (2) Time/Temp. Transformers. The secondary output of the Transformers, 12.5 to 15 VAC with a center tap, is supplied to terminals 1, 2, and 3 of the Time/Temp. Display. The Display works on a balanced input, and center tap voltage to each leg must be 1/2 the total reading. The speed side of the Time/Temp. Display is supplied, by the Conveyor Control, with the frequency of the pulses to the Conveyor Motor. These pulses are converted by the Time/Temp. Display into a read out of minutes and seconds.</p>
NOTE:	<p>The Conveyor Control uses a sensor and magnet, mounted on the Conveyor Motor, that senses when the motor is turning. If the motor is not turning, the Time/Temp. Display will show"--:--" in the window.</p> <p>The temperature portion of the display uses a Thermistor Probe to sense oven temperature. The Thermistor outputs a resistance proportional to oven temperature. This resistance is then converted by the Display into a temperature reading.</p> <p style="text-align: center;">OR:</p> <p>The temperature portion of the display uses a "J" type thermocouple to measure oven temperature. The thermocouple generates D.C. millivolts proportional to oven temperature. This millivolt reading is then converted by the display into a temperature reading.</p> <p>The oven utilizes (2) Temperature Display systems, one each for the left and right sides of the cooking chamber.</p>

SEQUENCE OF OPERATIONS / 1646, 1647, 1650, 1651

MODEL 1646 / 220-240 VAC / 50 HZ / NATURAL GAS
 MODEL 1647 / 220-240 VAC / 50 HZ / L.P. GAS
 MODEL 1650 / 220-240 VAC / 50 HZ / TOWN GAS
 MODEL 1651 / 220-240 VAC / 50 HZ / TOWN GAS

POWER SUPPLY	<p>Electrical power to be supplied to the oven by a three conductor service.</p> <p>Brown conductor is hot. Blue conductor is neutral. Green conductor is ground.</p>
CONTROL BOX AUTO COOL DOWN	<p>When the temperature in either one of the Control Boxes reaches 120°F ± 3°F (49°C ± 1.7°C), the Cooling Fan Thermostats will switch power to the Cooling Fans. The thermostats will interrupt power to the Cooling Fans when the temperature falls to 100°F ± 3°F (37°C ± 1.7°C).</p>
MAIN FAN CIRCUIT	<p>Line voltage is permanently supplied to a normally open contact of the oven power switch, through a 10A fuse to the normally open oven fan relay, and through a 3A fuse to the primary of the control circuit step down transformer (The transformer steps the voltage down to 120 VAC for the control circuit). 120 VAC is permanently supplied to the (2) normally open cooling fan thermostats, a normally open contact of the cool down relay, terminal #1 of the 20 -minute time delay module and to the normally open oven power switch. Closing the oven power switch supplies 120 VAC to the cool-down relay, its contacts now close, supplying 120 VAC to the (2) cooling fans. and enabling the 20 minute time delay module. The 20-minute time delay module supplies 120 VAC to the oven fan relay, its contact now closes supplying line voltage to the (2) main fan motors. 120 VAC is also supplied to the (2) time/temp transformers, the conveyor switch and the (2) electronic temperature controls.</p>
BURNER CIRCUIT	<p>NOTE: This oven utilizes (2) complete Burner/Temp. Control Systems. The sequence of operations is the same for each system. Closing the normally open oven power switch supplies line voltage through a 3A fuse, through the sail switch, through the gas pressure switch, through the Main Fan Air Pressure Switch, through the Hi-limit Thermostat, to the Ignition Control. The combustion motor is energized. The normally open combustion air switch closes upon sensing air pressure. After a pre-purge period of between 30 and 60 seconds, the Ignition Transformer and the Main Gas Valve are energized. Ignition should now occur.</p> <p>NOTE: The Cooling Fan Sail Switch is mounted in front of the cooling fan and is activated by the air flow of the Cooling Fan.</p>
TEMPERATURE CONTROL	<p>Closing the Oven Power Switch supplies 120 VAC (through the Step Down Transformer) to the Temperature Control Board. The 2.5k ohm Temperature Pot is adjusted to desired temperature. The Thermocouple will provide varying millivolts to the Temperature Controller. The Temperature Controller supplies 120 VAC to the Solenoid Valve at intermittent intervals to maintain desired temperature.</p>
CONVEYOR DRIVE	<p>Closing the Oven Power Switch supplies 120 VAC, through the contact of the Oven Power Relay, to the normally open Conveyor Switch. Closing the Conveyor Switch supplies 120 VAC, through a 3 Amp Fuse, to the primary of the Conveyor Control Transformer. The secondary of this Transformer supplies 10 VAC and 29 VAC to the Conveyor Control. The conveyor control supplies voltage pulses to the Conveyor Motor. The Conveyor Control Potentiometer varies the frequency of these pulses. The motor speed will increase or decrease, as the frequency of the pulses increase or decrease respectively.</p>
TIME/TEMP DISPLAY	<p>Closing the Oven Power Switch supplies 120 VAC, through the contact of the Oven Power Relay, to the primary of the (2)Time/Temp. Transformers. The secondary output of the Transformers, 12.5 to 15 VAC with a center tap, is supplied to terminals 1, 2, and 3 of the Time/Temp. Display. The Display works on a balanced input, and center tap voltage to each leg must be 1/2 the total reading. The speed side of the Time/Temp. Display is supplied, by the Conveyor Control, with the frequency of the pulses to the Conveyor Motor. These pulses are converted by the Time/Temp. Display into a read out of minutes and seconds.</p>
NOTE:	<p>The Conveyor Control uses a sensor and magnet, mounted on the Conveyor Motor, that senses when the motor is turning. If the motor is not turning, the Time/Temp. Display will show "--:--" in the window. The temperature portion of the display uses a</p>

	<p>Thermistor Probe to sense oven temperature. The Thermistor outputs a resistance proportional to oven temperature. This resistance is then converted by the Display into a temperature reading.</p> <p style="text-align: center;">OR:</p> <p>The temperature portion of the display uses a "J" type thermocouple to measure oven temperature. The thermocouple generates D.C. millivolts proportional to oven temperature. This millivolt reading is then converted by the display into a temperature reading.</p> <p>The oven utilizes (2) Temperature Display systems, one each for the left and right sides of the cooking chamber.</p>
--	---

SCHEMATIC / 1628, 1629

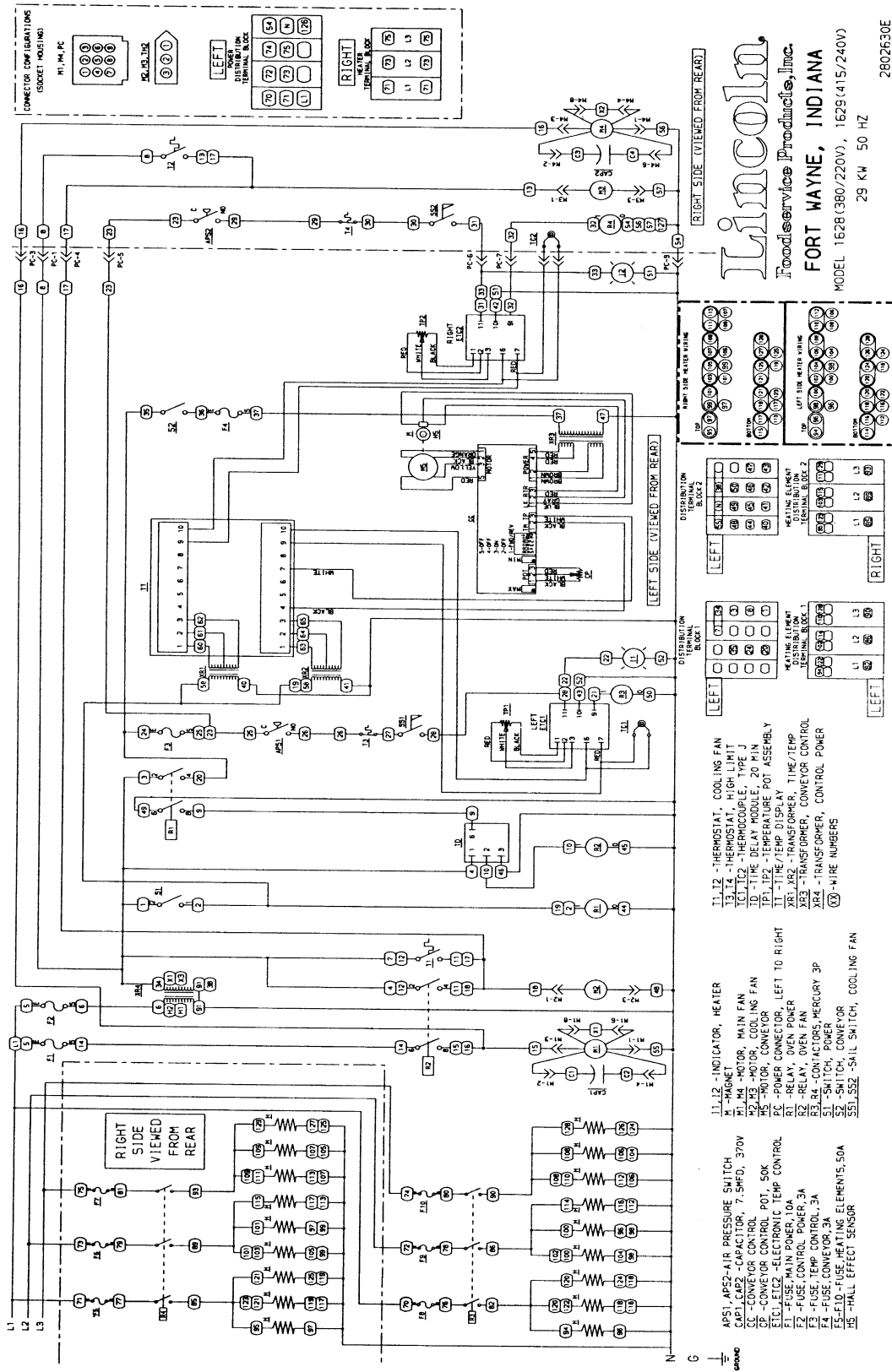

Lincoln
 Foodservice Products, Inc.
 FORT WAYNE, INDIANA
 MODEL 1628 (380/220V), 1629 (415/240V)
 29 KW 50 HZ
 2802630E

- AP51 - APS2-AIR PRESSURE SWITCH
- CAP1, CAP2 - CAPACITOR, 7.5MFD, 370V
- CC - CONVEYOR CONTROL POT. 50K
- CP - CONVEYOR CONTROL POT. 50K
- E1, E2, E3 - ELECTRONIC TEMP CONTROL
- F1 - FUSE, MAIN POWER, 10A
- F2 - FUSE, MAIN POWER, 3A
- F3 - FUSE, TEMP CONTROL, 3A
- F4 - FUSE, CONVEYOR 3A
- F5 - FUSE, HEATING ELEMENTS, 50A
- HS - HALL EFFECT SENSOR
- I1, I2 - INDICATOR, HEATER
- M - MAGNET
- M1, M4 - MOTOR, MAIN FAN
- M2, M3 - MOTOR, COOLING FAN
- M5 - MOTOR, CONVEYOR
- PC - POWER CONNECTOR, LEFT TO RIGHT
- R1 - RELAY, OVEN FAN
- R2 - RELAY, CONVEYOR, MERCURY 3P
- S1 - SWITCH, CONVEYOR
- S2 - SWITCH, CONVEYOR
- S51, S52 - SA-IL SWITCH, COOLING FAN
- T1, T2 - THERMOSTAT, COOLING FAN
- T1, T2 - THERMOCOUPLE, TYPE J
- TD - TIME DELAY MODULE, 20 MIN
- TP1, TP2 - TEMPERATURE POT ASSEMBLY
- TI - TIME/TEMP DISPLAY
- TR1, TR2 - TRANSFORMER, TIME/TEMP
- TR3 - TRANSFORMER, CONVEYOR CONTROL
- TR4 - TRANSFORMER, CONTROL POWER
- (X) - WIRE NUMBERS

SCHEMATIC / 1646, 1647, 1650, 1651

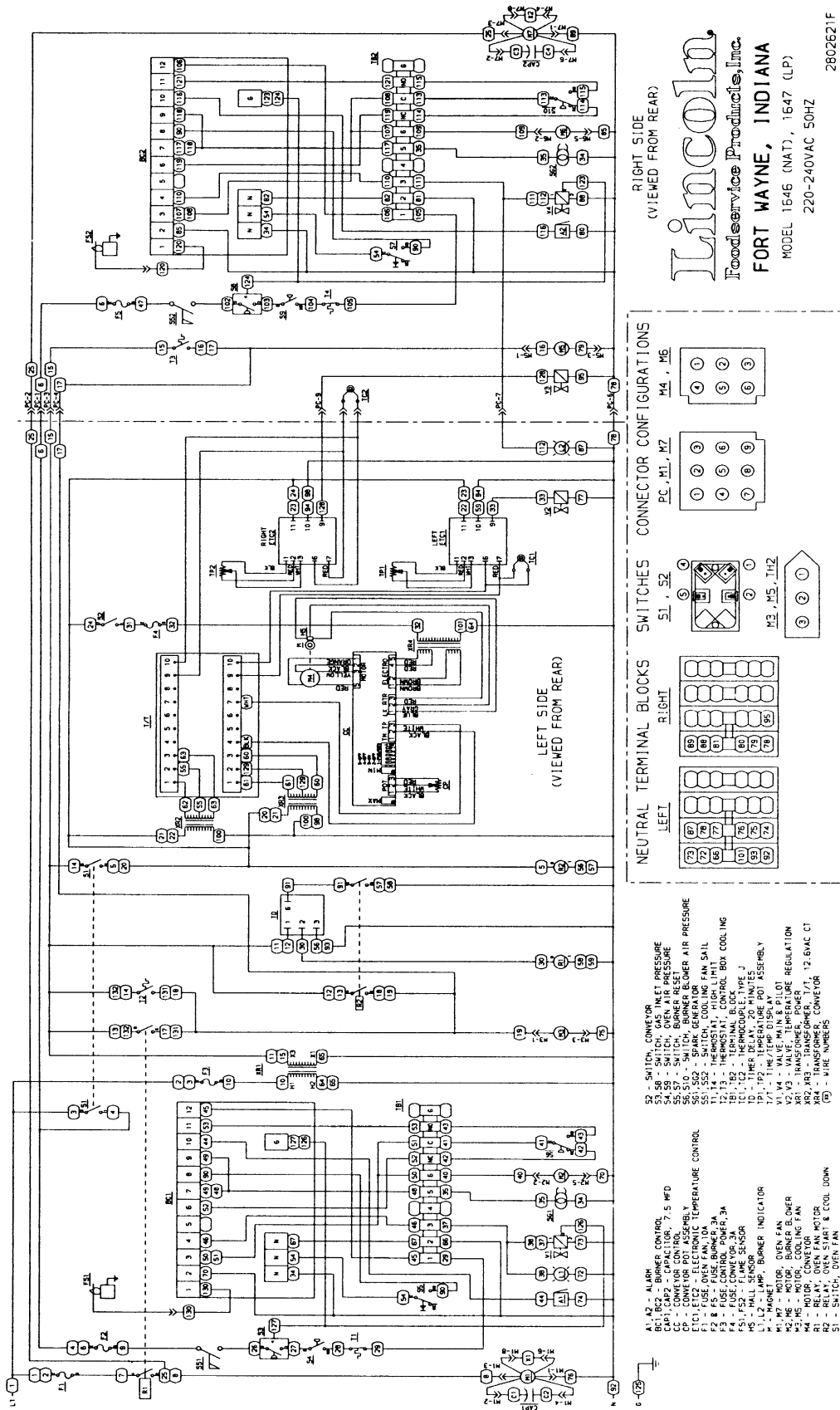

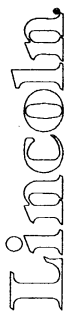
Foodservice Products, Inc.
FORT WAYNE, INDIANA
 MODEL 1646 (NAT), 1647 (LP)
 220-240VAC 50HZ
 2802621F

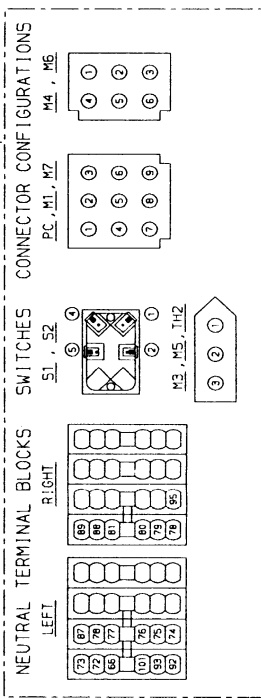

- S1 - SWITCH, CONDENSER
- S2 - SWITCH, GAS INLET PRESSURE
- S4, S5 - SWITCH, BURNER RESER AIR PRESSURE
- S5, S7 - SWITCH, BURNER RESER AIR PRESSURE
- S6, S8 - SWITCH, BURNER RESER AIR PRESSURE
- S9, S10 - SPARK GENERATOR
- S11, S12 - SWITCH, COOLING FAN SAIL
- T1, T2 - THERMISTAT, CONTROL BOX COOLING
- T3 - THERMISTAT, CONTROL BOX COOLING
- TR1, TR2 - THERMAL BLOCK, W/ J
- TR3 - THERMAL BLOCK, W/ J
- U1, U2 - THERMOCOUPLE, W/ J
- U3 - THERMOCOUPLE, W/ J
- U4 - THERMOCOUPLE, W/ J
- U5 - THERMOCOUPLE, W/ J
- U6 - THERMOCOUPLE, W/ J
- U7 - THERMOCOUPLE, W/ J
- U8 - THERMOCOUPLE, W/ J
- U9 - THERMOCOUPLE, W/ J
- U10 - THERMOCOUPLE, W/ J
- U11 - THERMOCOUPLE, W/ J
- U12 - THERMOCOUPLE, W/ J
- U13 - THERMOCOUPLE, W/ J
- U14 - THERMOCOUPLE, W/ J
- U15 - THERMOCOUPLE, W/ J
- U16 - THERMOCOUPLE, W/ J
- U17 - THERMOCOUPLE, W/ J
- U18 - THERMOCOUPLE, W/ J
- U19 - THERMOCOUPLE, W/ J
- U20 - THERMOCOUPLE, W/ J
- U21 - THERMOCOUPLE, W/ J
- U22 - THERMOCOUPLE, W/ J
- U23 - THERMOCOUPLE, W/ J
- U24 - THERMOCOUPLE, W/ J
- U25 - THERMOCOUPLE, W/ J
- U26 - THERMOCOUPLE, W/ J
- U27 - THERMOCOUPLE, W/ J
- U28 - THERMOCOUPLE, W/ J
- U29 - THERMOCOUPLE, W/ J
- U30 - THERMOCOUPLE, W/ J
- U31 - THERMOCOUPLE, W/ J
- U32 - THERMOCOUPLE, W/ J
- U33 - THERMOCOUPLE, W/ J
- U34 - THERMOCOUPLE, W/ J
- U35 - THERMOCOUPLE, W/ J
- U36 - THERMOCOUPLE, W/ J
- U37 - THERMOCOUPLE, W/ J
- U38 - THERMOCOUPLE, W/ J
- U39 - THERMOCOUPLE, W/ J
- U40 - THERMOCOUPLE, W/ J
- U41 - THERMOCOUPLE, W/ J
- U42 - THERMOCOUPLE, W/ J
- U43 - THERMOCOUPLE, W/ J
- U44 - THERMOCOUPLE, W/ J
- U45 - THERMOCOUPLE, W/ J
- U46 - THERMOCOUPLE, W/ J
- U47 - THERMOCOUPLE, W/ J
- U48 - THERMOCOUPLE, W/ J
- U49 - THERMOCOUPLE, W/ J
- U50 - THERMOCOUPLE, W/ J
- U51 - THERMOCOUPLE, W/ J
- U52 - THERMOCOUPLE, W/ J
- U53 - THERMOCOUPLE, W/ J
- U54 - THERMOCOUPLE, W/ J
- U55 - THERMOCOUPLE, W/ J
- U56 - THERMOCOUPLE, W/ J
- U57 - THERMOCOUPLE, W/ J
- U58 - THERMOCOUPLE, W/ J
- U59 - THERMOCOUPLE, W/ J
- U60 - THERMOCOUPLE, W/ J
- U61 - THERMOCOUPLE, W/ J
- U62 - THERMOCOUPLE, W/ J
- U63 - THERMOCOUPLE, W/ J
- U64 - THERMOCOUPLE, W/ J
- U65 - THERMOCOUPLE, W/ J
- U66 - THERMOCOUPLE, W/ J
- U67 - THERMOCOUPLE, W/ J
- U68 - THERMOCOUPLE, W/ J
- U69 - THERMOCOUPLE, W/ J
- U70 - THERMOCOUPLE, W/ J
- U71 - THERMOCOUPLE, W/ J
- U72 - THERMOCOUPLE, W/ J
- U73 - THERMOCOUPLE, W/ J
- U74 - THERMOCOUPLE, W/ J
- U75 - THERMOCOUPLE, W/ J
- U76 - THERMOCOUPLE, W/ J
- U77 - THERMOCOUPLE, W/ J
- U78 - THERMOCOUPLE, W/ J
- U79 - THERMOCOUPLE, W/ J
- U80 - THERMOCOUPLE, W/ J
- U81 - THERMOCOUPLE, W/ J
- U82 - THERMOCOUPLE, W/ J
- U83 - THERMOCOUPLE, W/ J
- U84 - THERMOCOUPLE, W/ J
- U85 - THERMOCOUPLE, W/ J
- U86 - THERMOCOUPLE, W/ J
- U87 - THERMOCOUPLE, W/ J
- U88 - THERMOCOUPLE, W/ J
- U89 - THERMOCOUPLE, W/ J
- U90 - THERMOCOUPLE, W/ J
- U91 - THERMOCOUPLE, W/ J
- U92 - THERMOCOUPLE, W/ J
- U93 - THERMOCOUPLE, W/ J
- U94 - THERMOCOUPLE, W/ J
- U95 - THERMOCOUPLE, W/ J
- U96 - THERMOCOUPLE, W/ J
- U97 - THERMOCOUPLE, W/ J
- U98 - THERMOCOUPLE, W/ J
- U99 - THERMOCOUPLE, W/ J
- U100 - THERMOCOUPLE, W/ J

- A1 - ALARM
- B1 - BURNER CONTROL
- CB1, CAP2 - CAPACITOR, 7.5 MFD
- CC - CONVERTOR CONTROL ASSEMBLY
- CT1, CT2 - ELECTRONIC TEMPERATURE CONTROL
- F1 - FUSE, OVEN FAN, 10A
- F2 - FUSE, OVEN FAN, 10A
- F3 - FUSE, OVEN FAN, 10A
- F4 - FUSE, OVEN FAN, 10A
- F5 - FUSE, OVEN FAN, 10A
- F6 - FUSE, OVEN FAN, 10A
- F7 - FUSE, OVEN FAN, 10A
- F8 - FUSE, OVEN FAN, 10A
- F9 - FUSE, OVEN FAN, 10A
- F10 - FUSE, OVEN FAN, 10A
- F11 - FUSE, OVEN FAN, 10A
- F12 - FUSE, OVEN FAN, 10A
- F13 - FUSE, OVEN FAN, 10A
- F14 - FUSE, OVEN FAN, 10A
- F15 - FUSE, OVEN FAN, 10A
- F16 - FUSE, OVEN FAN, 10A
- F17 - FUSE, OVEN FAN, 10A
- F18 - FUSE, OVEN FAN, 10A
- F19 - FUSE, OVEN FAN, 10A
- F20 - FUSE, OVEN FAN, 10A
- F21 - FUSE, OVEN FAN, 10A
- F22 - FUSE, OVEN FAN, 10A
- F23 - FUSE, OVEN FAN, 10A
- F24 - FUSE, OVEN FAN, 10A
- F25 - FUSE, OVEN FAN, 10A
- F26 - FUSE, OVEN FAN, 10A
- F27 - FUSE, OVEN FAN, 10A
- F28 - FUSE, OVEN FAN, 10A
- F29 - FUSE, OVEN FAN, 10A
- F30 - FUSE, OVEN FAN, 10A
- F31 - FUSE, OVEN FAN, 10A
- F32 - FUSE, OVEN FAN, 10A
- F33 - FUSE, OVEN FAN, 10A
- F34 - FUSE, OVEN FAN, 10A
- F35 - FUSE, OVEN FAN, 10A
- F36 - FUSE, OVEN FAN, 10A
- F37 - FUSE, OVEN FAN, 10A
- F38 - FUSE, OVEN FAN, 10A
- F39 - FUSE, OVEN FAN, 10A
- F40 - FUSE, OVEN FAN, 10A
- F41 - FUSE, OVEN FAN, 10A
- F42 - FUSE, OVEN FAN, 10A
- F43 - FUSE, OVEN FAN, 10A
- F44 - FUSE, OVEN FAN, 10A
- F45 - FUSE, OVEN FAN, 10A
- F46 - FUSE, OVEN FAN, 10A
- F47 - FUSE, OVEN FAN, 10A
- F48 - FUSE, OVEN FAN, 10A
- F49 - FUSE, OVEN FAN, 10A
- F50 - FUSE, OVEN FAN, 10A
- F51 - FUSE, OVEN FAN, 10A
- F52 - FUSE, OVEN FAN, 10A
- F53 - FUSE, OVEN FAN, 10A
- F54 - FUSE, OVEN FAN, 10A
- F55 - FUSE, OVEN FAN, 10A
- F56 - FUSE, OVEN FAN, 10A
- F57 - FUSE, OVEN FAN, 10A
- F58 - FUSE, OVEN FAN, 10A
- F59 - FUSE, OVEN FAN, 10A
- F60 - FUSE, OVEN FAN, 10A
- F61 - FUSE, OVEN FAN, 10A
- F62 - FUSE, OVEN FAN, 10A
- F63 - FUSE, OVEN FAN, 10A
- F64 - FUSE, OVEN FAN, 10A
- F65 - FUSE, OVEN FAN, 10A
- F66 - FUSE, OVEN FAN, 10A
- F67 - FUSE, OVEN FAN, 10A
- F68 - FUSE, OVEN FAN, 10A
- F69 - FUSE, OVEN FAN, 10A
- F70 - FUSE, OVEN FAN, 10A
- F71 - FUSE, OVEN FAN, 10A
- F72 - FUSE, OVEN FAN, 10A
- F73 - FUSE, OVEN FAN, 10A
- F74 - FUSE, OVEN FAN, 10A
- F75 - FUSE, OVEN FAN, 10A
- F76 - FUSE, OVEN FAN, 10A
- F77 - FUSE, OVEN FAN, 10A
- F78 - FUSE, OVEN FAN, 10A
- F79 - FUSE, OVEN FAN, 10A
- F80 - FUSE, OVEN FAN, 10A
- F81 - FUSE, OVEN FAN, 10A
- F82 - FUSE, OVEN FAN, 10A
- F83 - FUSE, OVEN FAN, 10A
- F84 - FUSE, OVEN FAN, 10A
- F85 - FUSE, OVEN FAN, 10A
- F86 - FUSE, OVEN FAN, 10A
- F87 - FUSE, OVEN FAN, 10A
- F88 - FUSE, OVEN FAN, 10A
- F89 - FUSE, OVEN FAN, 10A
- F90 - FUSE, OVEN FAN, 10A
- F91 - FUSE, OVEN FAN, 10A
- F92 - FUSE, OVEN FAN, 10A
- F93 - FUSE, OVEN FAN, 10A
- F94 - FUSE, OVEN FAN, 10A
- F95 - FUSE, OVEN FAN, 10A
- F96 - FUSE, OVEN FAN, 10A
- F97 - FUSE, OVEN FAN, 10A
- F98 - FUSE, OVEN FAN, 10A
- F99 - FUSE, OVEN FAN, 10A
- F100 - FUSE, OVEN FAN, 10A

- M1 - MAGNETIC OVEN FAN
- M2 - MOTOR, BURNER BLOWER
- M3 - MOTOR, COOLING FAN
- M4 - MOTOR, COOLING FAN
- M5 - MOTOR, COOLING FAN
- M6 - MOTOR, COOLING FAN
- M7 - MOTOR, COOLING FAN
- M8 - MOTOR, COOLING FAN
- M9 - MOTOR, COOLING FAN
- M10 - MOTOR, COOLING FAN
- M11 - MOTOR, COOLING FAN
- M12 - MOTOR, COOLING FAN
- M13 - MOTOR, COOLING FAN
- M14 - MOTOR, COOLING FAN
- M15 - MOTOR, COOLING FAN
- M16 - MOTOR, COOLING FAN
- M17 - MOTOR, COOLING FAN
- M18 - MOTOR, COOLING FAN
- M19 - MOTOR, COOLING FAN
- M20 - MOTOR, COOLING FAN
- M21 - MOTOR, COOLING FAN
- M22 - MOTOR, COOLING FAN
- M23 - MOTOR, COOLING FAN
- M24 - MOTOR, COOLING FAN
- M25 - MOTOR, COOLING FAN
- M26 - MOTOR, COOLING FAN
- M27 - MOTOR, COOLING FAN
- M28 - MOTOR, COOLING FAN
- M29 - MOTOR, COOLING FAN
- M30 - MOTOR, COOLING FAN
- M31 - MOTOR, COOLING FAN
- M32 - MOTOR, COOLING FAN
- M33 - MOTOR, COOLING FAN
- M34 - MOTOR, COOLING FAN
- M35 - MOTOR, COOLING FAN
- M36 - MOTOR, COOLING FAN
- M37 - MOTOR, COOLING FAN
- M38 - MOTOR, COOLING FAN
- M39 - MOTOR, COOLING FAN
- M40 - MOTOR, COOLING FAN
- M41 - MOTOR, COOLING FAN
- M42 - MOTOR, COOLING FAN
- M43 - MOTOR, COOLING FAN
- M44 - MOTOR, COOLING FAN
- M45 - MOTOR, COOLING FAN
- M46 - MOTOR, COOLING FAN
- M47 - MOTOR, COOLING FAN
- M48 - MOTOR, COOLING FAN
- M49 - MOTOR, COOLING FAN
- M50 - MOTOR, COOLING FAN
- M51 - MOTOR, COOLING FAN
- M52 - MOTOR, COOLING FAN
- M53 - MOTOR, COOLING FAN
- M54 - MOTOR, COOLING FAN
- M55 - MOTOR, COOLING FAN
- M56 - MOTOR, COOLING FAN
- M57 - MOTOR, COOLING FAN
- M58 - MOTOR, COOLING FAN
- M59 - MOTOR, COOLING FAN
- M60 - MOTOR, COOLING FAN
- M61 - MOTOR, COOLING FAN
- M62 - MOTOR, COOLING FAN
- M63 - MOTOR, COOLING FAN
- M64 - MOTOR, COOLING FAN
- M65 - MOTOR, COOLING FAN
- M66 - MOTOR, COOLING FAN
- M67 - MOTOR, COOLING FAN
- M68 - MOTOR, COOLING FAN
- M69 - MOTOR, COOLING FAN
- M70 - MOTOR, COOLING FAN
- M71 - MOTOR, COOLING FAN
- M72 - MOTOR, COOLING FAN
- M73 - MOTOR, COOLING FAN
- M74 - MOTOR, COOLING FAN
- M75 - MOTOR, COOLING FAN
- M76 - MOTOR, COOLING FAN
- M77 - MOTOR, COOLING FAN
- M78 - MOTOR, COOLING FAN
- M79 - MOTOR, COOLING FAN
- M80 - MOTOR, COOLING FAN
- M81 - MOTOR, COOLING FAN
- M82 - MOTOR, COOLING FAN
- M83 - MOTOR, COOLING FAN
- M84 - MOTOR, COOLING FAN
- M85 - MOTOR, COOLING FAN
- M86 - MOTOR, COOLING FAN
- M87 - MOTOR, COOLING FAN
- M88 - MOTOR, COOLING FAN
- M89 - MOTOR, COOLING FAN
- M90 - MOTOR, COOLING FAN
- M91 - MOTOR, COOLING FAN
- M92 - MOTOR, COOLING FAN
- M93 - MOTOR, COOLING FAN
- M94 - MOTOR, COOLING FAN
- M95 - MOTOR, COOLING FAN
- M96 - MOTOR, COOLING FAN
- M97 - MOTOR, COOLING FAN
- M98 - MOTOR, COOLING FAN
- M99 - MOTOR, COOLING FAN
- M100 - MOTOR, COOLING FAN

TROUBLESHOOTING GAS OVENS

MODEL 1600, 1601, 1652
1600-000-DB, 1601-000-DB

NOTE: When checking components on left side of unit, be sure to check wire harness across back of oven for proper connections in power connector, (marked P. C. on Schematic Diagram, inside control box cover).

SYMPTOM	POSSIBLE CAUSE	EVALUATION
Oven fan(s) will not run	Incoming Power Supply	Check breakers/Reset if required/ Call Power Company if needed.
	Power Switch	Check continuity between switch terminals.
	Oven Power Relay	Check for 120 VAC to the relay coil. If voltage is not present, trace wiring back to the fan switch. If voltage is present, check to insure contacts are closing. Check for 120 VAC supplied t terminal #2 of the relay.
	20 Minute Time Delay	Check for 120 VAC at terminal #1 to neutral on the 20 minute timer. If no voltage is present, trace wiring back to the power supply. If voltage is present at terminal #1, check for 120 VAC at terminal #2 to neutral. If no voltage is present, and the oven power relay is closed, replace the 20 minute timer.
	Oven Fan Relay	Check for 120 VAC to coil of the oven fan relay. If no voltage is present, trace wiring back to terminal #2 of the 20minute timer. Check for 120 VAC at terminals #2 and #6 of the relay, if no voltage is present, trace wiring back to the power supply. If voltage is present at the relay coil, check to insure the contacts are closing.
	Fuse, Fan, 10A	Check, replace if necessary.
	Fuseholder	Check, replace if necessary
	Capacitor(s)	Check for opens, shorts, or grounds.
No main fan cool down	Motor(s)	Check for opens, shorts, or grounds. WITH POWER OFF: turn the fan blade(s) to check for locked rotor.
	20 Minute Time Delay	Check for 120 VAC at terminal #2 to neutral while oven is "on". Turn off the main fan switch, 120 VAC should continue to be present for 20 minutes. If voltage is not present for approx. 20 minutes, replace the timer.
Oven Fan Relay	Oven Fan Relay	Check if relay is operating and that the contacts remain closed during the 20 minute cool down.
	20 Minute Time Delay	120 VAC at terminal #2 should discontinue approximately 20 minutes after main fan is switched off. If the oven power relay contacts are open, and the voltage continues at terminal #2 of the 20 minute timer, for more than 20 mins., replace the timer.
Main fan runs after 20 minute cool down	Oven Power Relay	Contacts should open when main fan switch is turned off.
	20 Minute Time Delay	120 VAC at terminal #2 should discontinue approximately 20 minutes after main fan is switched off. If the oven power relay contacts are open, and the voltage continues at terminal #2 of the 20 minute timer, for more than 20 mins., replace the timer.
	Oven Fan Relay	Check to insure that the contacts are opening after the coil is de-energized.
No control box cooling	Power Switch Oven Power Relay 20 Minute Time Delay Oven Fan Relay	(SEE MAIN FAN WILL NOT RUN)
	Fuse, Cooling Fans (3A)	Check, replace if necessary.
	Fuseholder	Check, replace if necessary
	Cooling Fan(s)	120 VAC should now be at these motors. If voltage is present, check motor(s) for shorts, opens, or grounds WITH POWER OFF: check for locked rotor.

No automatic control box cooling	Incoming Power Supply	Check circuit breakers, reset if required. Call the Power Company if needed.
	Cooling Fan Thermostat(s)	Check the cooling fan thermostat. (Thermostat closes at 120°F and opens at 100°F.) With the cooling fan thermostat pre-heated, check for continuity. If switch is open, replace.
	Fuse, Cooling Fans (3A) Fuseholder Cooling Fan(s)	Check, replace if necessary. Check, replace if necessary. 120 VAC should now be at these motors. If voltage is present, check motor(s) for shorts, opens, or grounds. WITH POWER OFF: check for locked rotor .
Cooling fans continue to run after 20 minute cool down	Cooling Fan Thermostat(s)	Thermostat is normally open and may have closed if control box temperature is 120°F or above.
	Oven Fan Relay	Check to insure contacts are opening after the 20 minute cool down.
Oven will not heat	Gas Supply	Check for adequate gas supply and closed manual gas shut-off.
	Main Fan(s)	If not operating, refer to "Oven fan will not run." Page 13 "
	Burner relay	120 VAC should be present at the coil of burner relay. If voltage is not present, trace wiring back to the oven power relay and back to power supply if needed. If voltage is present, check to insure the relay contacts are closing. Replace as necessary

NOTE: These ovens utilize 2 complete Burner/Temperature control systems. Each system will follow the same Troubleshooting Sequence.

	Centrifugal Switch of Main Fan	Check for 120 VAC supplied to the centrifugal switch, if voltage is not present, trace the wiring back to the burner relay. Check for 120 VAC out of the centrifugal switch. If voltage is supplied to the centrifugal switch, and motor is running, but there is no voltage out of the centrifugal switch, replace the fan motor. (NOTE: see Schematic Diagram for proper wire numbers on motors)
	Fuse, Burner 10A	Check, replace if necessary.
	Fuseholder	Check, replace if necessary.
	Burner Blower Motor	Check for 120 VAC supply to the burner blower motor, if present and motor does not run, replace the motor. WITH POWER OFF: turn blower wheel to check for locked rotor.
	Centrifugal Switch of Burner Blower Motor	Check for 120 VAC supply to the centrifugal switch of burner blower motor (see Schematic for proper wire numbers). If no voltage is present, trace wiring back to the fuseholder. If voltage is present, check for 120 VAC at the output of the centrifugal switch. If there is no output, and the burner blower motor is running, replace the burner blower motor.

	Control Box Cooling Fan	Check to insure the control box cooling fan is operating properly. If the cooling fan is not operating, refer to "No control box cooling" Page 14".
	Cooling Fan Sail Switch	(NOTE: the cooling fan sail switch is located in front of the cooling fan and is activated by the air flow from the cooling fan.) Check for 120 VAC supply to the sail switch (see Schematic for proper wire numbers). Visually check to see the sail switch is closing as cooling fan is running, if the sail switch is not closing, check for obstructions or damage to the sail switch. If the sail switch is closing, check for 120 VAC out of the sail switch. If there is no voltage, and the sail switch is closed, replace the sail switch.
	Burner Transformer	Check for 120 VAC to primary of the 24 VAC burner transformer. If voltage is not present, trace wiring back to the sail switch. If voltage is present, check for 24 VAC at the secondary, if no secondary voltage is present, replace the transformer.
	Ignition Control	Check for 24 VAC supply to the ignition control at terminals marked 24V and 24Vgnd. If voltage is not present, trace wiring back to the 24 VAC transformer. Check for 120 VAC supply to the ignition control at terminals L1 and L2. If no voltage is present, trace wiring back to terminal #11 on the temperature control. If the above checks are okay, proceed. The ignition control should switch 120 VAC to the hot surface igniter, across the (2) terminals marked HSI. If no voltage is present, replace ignition control.
	Hot Surface Igniter(located inside Burner Assy.)	If 120 VAC is present at HSI terminals, visually check to see that the hot surface igniter is heating (igniter may be viewed through port glass in end of burner tube). The igniter should glow bright red. Check all connections to be sure they are tight. If the igniter does not heat, replace.
	Ignition Control	After 45 seconds of hot surface igniter pre-heat, the ignition control will switch 24 VAC to the gas control valves. Check for 24 VAC output from the ignition control, and across terminals marked "valve" and "valve gnd". If no voltage is present, replace the ignition control. NOTE: the ignition control contains a safety lock-out circuit. If a flame is not detected within 6 seconds after the gas control valve is energized, the ignition control will lock-out. To reset, turn the burner switch "off", wait 45 seconds and switch the burner system "on" to retry ignition
	Gas Control Valves	Check for 24 VAC supplied to the gas control valves. If voltage is present, the valves should open. Check for gas pressure at the pressure tap, located in the gas piping just prior to the burner. If there is no gas pressure, and the voltage is supplied to valves, check piping for obstructions. If there are no obstructions, replace gas control valves. NOTE: the red burner indicator light is wired in parallel with the gas control valves. When 24 VAC is supplied to the gas control valves the red burner indicator light is also energized.

Flame will not stay lit	Hot Surface Igniter	The ignition control will keep the gas control valves energized for 6 seconds. At the end of 6 seconds, the hot surface igniter must sense a flame, or, the ignition control will go into lock- out. (The ignition control requires a minimum of 0.8 microamps D.C.) To check the flame sensing operation, connect a digital multimeter (capable of measuring D.C. micro-amps) between the "ground" terminal on ignition control and the ground lead. NOTE: This is a current measurement and the meter must be connected in series. If these readings are not achieved, check bypass orifice for obstructions, if bypass orifice is clear, replace the hot surface igniter. NOTE: The D.C. micro amp test must be conducted with the oven in low flame (bypass) operation. Turn the temperature control to its lowest setting
	Power Supply	If there is sufficient micro-amp current, but the flame will not stay lit, check for proper polarity of the 120 VAC power supply
	Ignition Control	If there is sufficient micro-amp current, and the 120 VAC polarity is correct, but the flame will not stay lit, replace the ignition control. NOTE: Check for proper ground connection of the ignition control.
Low flame is on, but no main flame.	NOTE: Flame should be present at this time	Check for 120 VAC supply at terminal #11 to neutral on the temperature control. If no voltage is present, trace the wiring back to 10 A fuse. Turn the temperature adjustment knob to its maximum temperature position and check for 120 VAC at the load terminal (#9) and neutral. If 120 VAC is present and unit is not heating, refer to "Temperature Regulation Valve" for next check. If 120 VAC is not present, proceed.
	Thermocouple Probe	WITH POWER ON AND THERMOCOUPLE LEADS ATTACHED TO THE TEMPERATURE CONTROL BOARD: measure the D. C. millivolt output of these leads. Refer to the thermocouple chart page 43 for proper readings. If these readings are not achieved, replace the thermocouple.
	Temperature Control Potentiometer	WITH POWER OFF: remove the potentiometer leads from the temperature control board and measure ohms from black to white leads. The reading should be from 0 to 2.5k ohms \pm 10% as the dial of the potentiometer is turned throughout its full rotation. From black to red leads, the reading should be 2.5k ohms \pm 10% (constant) throughout the full rotation of the dial. If these readings are not achieved, replace the potentiometer. If the thermocouple probe and the control potentiometer check good, then the problem is usually with the temperature control board.
	Temperature Regulation Valve	If 120 VAC is present on the temperature control board at load terminal (#9) to neutral, check for voltage at the temperature regulation valve. If voltage is present, listen for the valve to open and close. Also check for opens or shorts in the coil. Replace as necessary.

Intermittent Heating	Thermal/Overload	The main fan motors, burner blower motors, and cooling fan motors are equipped with internal thermal protection and will cease to operate if overheating occurs. As the motors overheat and then cool, this will cause the units to cycle on and off intermittently. Improper ventilation or preventive maintenance may cause this. Also, most of the problems listed under "Oven will not heat" on Page 14 can cause intermittent failure.
----------------------	------------------	---

NOTE: The 1600-000-DB series ovens utilize 2 complete conveyor drive systems.

Conveyor will not run	Conveyor Switch	Check for 120 VAC to conveyor switch. If no voltage is present, trace wiring back to the oven fan switch. WITH POWER OFF: Check continuity between switch terminals.
	Conveyor Fuse (3A)	Check, replace if necessary.
	Fuseholder	Check, replace if necessary.
	Conveyor Control (Stepper) Transformer	Check for 120 VAC supply to primary of transformer, if voltage is not present, trace wiring back to the fuseholder. If voltage is present check for output voltage from the transformer secondary NOTE: this control transformer outputs (2) secondary voltages Red Leads 29 VAC Brown Leads 10 VAC If BOTH secondary voltages are not present, replace the transformer.
	Speed Adjustment Potentiometer	This is a 0 to 50k ohm, 10 turn Brown Leads 10 VAC potentiometer. WITH POWER OFF: remove the 3 pin potentiometer cable plug from the motor control board. With a digital multimeter, check the ohm reading across the red lead to the black lead, this reading should be 50k ohms \pm 5% as the potentiometer is rotated through its 10 turn rotation. Place the meter leads on the red lead and white lead. Rotating the potentiometer slowly, from low to high, the meter should show an even transition from 0 to 50k ohms \pm 5% through the 10 turn rotation of the potentiometer. There should be no dead or open spots through the 10 turns of the potentiometer. Check all three leads to ground. There should be no continuity to ground. If any of the above checks fail, replace the potentiometer.
	Conveyor Motor (Stepper) Control	NOTE: if the conveyor drive motor becomes jammed or begins to run at an uncontrolled speed, the conveyor motor will stop running. To reset, turn off the conveyor switch, wait 30 seconds, turn the conveyor switch on. If the motor does not run after attempting re-set, check for 2 to 29 VAC across the motor terminals 1 to 2 and 3 to 5 on the conveyor motor control. If voltage is not present at both sets of terminals, replace control.
Conveyor Drive(Stepper) Motor	Check the drive sprocket on motor output shaft to insure that it is tight. Check motor windings; measurements should be approximately 2 ohms. Terminal 1-5, 2-6, 3-7, 4-8. WITH POWER OFF: Turn the motor shaft to check for jammed gear box. If motor shaft will not turn, replace conveyor drive (stepper) motor.	

Time/Temp. Display inoperative NOTE: these units utilize (2) complete temperature display systems containing like components.	12 VAC Power Supply(Transformer)	Measure the transformer primary for a nominal 120 VAC input, if voltage is not present, trace wiring back to the power supply. Measure the secondary output, which will normally be 12-15 VAC. Voltage across terminals 1 and 3 on the time/temp. display should read 12-15 VAC. Terminals 1-2 and 2-3 should be 1/2 the voltage reading 1 to 3. If the above secondary readings are not achieved, replace transformer.
	Time/Temp. Display	If proper voltage is present at terminals 1, 2, and 3 on time/temp. display, but the display is not lighted, recheck all connections for tightness. If time/temp. display is still not operating, replace the time/temp. display
Temp. display out or erratic	NOTE: Time/Temp displays uses two types of temperature sensor, Thermistor Probe2 yellow wires, Thermo- couple Probe 1 red wire and 1 white wire	Connect the thermocouple of a pyrometer to the thermocouple on the temperature control board. (Be sure to maintain proper polarity of thermocouple leads- see Adjustment Section for proper procedure .) The pyrometer will now indicate oven temperature
	Thermistor Probe	Disconnect the yellow tipped thermistor leads from the time/temp. terminals 9 and 10. Measure the resistance of the thermistor probe. See chart on page 43 for proper resistance readings. Inspect the thermistor bulb for its proper location in its spring holder. Check for short in leads where they enter the sensor bulb. Also check each thermistor lead for short to ground.
	Thermocouple Probe	Measure D.C. millivolts at terminals 9 and 10 on the time/temp display. See thermocouple chart on page 43 for proper readings. Replace thermocouple if proper readings are not achieved. If readings are correct on the thermocouple, replace time/temp display.
	Power Supply	If a strange or unusual behavior is experienced, such as a rolling of numbers, or lock-up at a given number, first check for a display circuit lock-up. A voltage spike or surge in the incoming power lines may cause this. To eliminate this condition, remove power from the time/temp. display by shutting off the main fan switch for 15 seconds. This should eliminate the problem. If this does not solve the problem, it may be coming in through the Commercial power lines. Suggest that customer contact their power company for evaluation.
Temp. display inaccurate, erratic, or inoperative	Time/Temp. Display	Perform the power supply check, the thermistor probe check, and then perform the time/temp. simulator test. Refer to page 36 & 37 for instructions. Remember, when using the time/temp. simulator, remove all leads from the back of the time/temp. display except the 3 power leads. After completion of the test, and if re-installing time/temp. display back in the oven, the dip switches must be reset for oven operation, and the time/temp. display must be recalibrated. If readings are not achieved, replace display.

Time Display inaccurate, erratic, or inoperative		Perform all checks as in the above evaluation. If the time check is okay, refer to the next section.
	Conveyor Drive (Stepper) Motor	Check to see if the conveyor drive (stepper) motor is running. If motor is not running, refer to "Conveyor will not run" on Page 23.
	Magnet	Check to insure that the magnet (cemented to shaft of conveyor drive [stepper] motor) has not been damaged, or come loose from motor shaft. Replace as needed.
	Hall Effect Sensor	Check for any physical damage to Hall Effect sensor (mounted on conveyor drive [stepper] motor). Check all wiring and connections for damage.
	Conveyor Drive (Stepper) Control	Check all connections for tightness or proper location and check all wiring for visible damage. Replace as needed. If there is still no time display, wire in (temporarily) a new conveyor drive control. If there is still no time display, reconnect original conveyor drive control. Replace Hall Effect Sensor.

TROUBLESHOOTING / 1622, 1623, 1628, 1629

ELECTRIC OVENS

NOTE: When checking components on left side of unit, be sure to check wire harness across back of oven for proper connections in power connectors, (marked P.C. on Schematic Diagram, located inside motor cover).

SYMPTOM	POSSIBLE CAUSE	EVALUATION
Oven fan(s) will not run	Incoming Power Supply	Check breakers/Reset if required/ Call Power Company if needed.
	Fuse, Main Fan 10A	Check, replace if necessary.
	Fuseholder	Check, replace if necessary.
	Fuse, Transformer 3A 1628	Check, replace if necessary
	Fuseholder 1629	Check, replace if necessary
	Transformer Power Only	120 VAC +_ 10% should be present at secondary of transformer. If proper voltage is not present, check transformer primary for proper input.
	Power Switch	Check for 120 VAC to switch Check continuity between switch terminals.
	Oven Power Relay	Check for 120 VAC to the relay coil. If voltage is not present, trace wiring back to the oven power switch. If voltage is present, check to insure contacts are closing. Check for 120 VAC supplied to terminal #2 of the relay. If power is not present, trace wiring back to transformer.
	20 Minute Time Delay	Check for 120 VAC at terminal #1 to neutral on the 20-minute timer. If no voltage is present, trace wiring back to the power supply. If voltage is present at terminal #1, check for 120 VAC at terminal #2 to neutral. If no voltage is present, and the oven power relay is closed, replace the 20-minute timer.
	Oven Fan Relay	Check for 120 VAC to coil of the oven fan relay. If no voltage is present, trace wiring back to terminal #2 of the 20 minute timer. Check for 120 VAC at terminal #2 and supply voltage at #6 of the relay, if no voltage is present, trace wiring back to the power supply. If voltage is present at the relay coil, check to insure the contacts are closing.
	Capacitor(s) Motor(s)	Check for opens, shorts, or grounds. WITH POWER OFF: turn the fan blade(s) to check for locked rotor.
Main fan runs after 20 minute cool down	20 Minute Time Delay	Check for 120 VAC at terminal #2 to neutral while oven is "on". Turn off the power switch, 120 VAC should continue to be present for approx. 20 minutes. If voltage is not present for approx. 20 minutes, replace the timer.
	Oven Fan Relay	Check if relay is operating and that the contacts remain closed during the 20 minute cool down.
	Oven Power Relay	Contacts should open when power switch is turned off and coil is de-energized.
	20 Minute Time Delay	120 VAC at terminal #2 should discontinue approximately 20 minutes after main fan is switched off. If the oven power relay contacts are open, and the voltage continues at terminal #2 of the 20 minute timer, replace the timer.
	Oven Fan Relay	Check to insure that the contacts are opening after the coil is de-energized.
	Fuse, Transformer 3A	Check, replace if necessary.
	Fuseholder 1628	Check, replace if necessary.

No control box cooling	Transformer, Power 1629 Only	120 VAC +_ 10% should be present at secondary of transformer. If proper voltage is not present, check transformer primary for proper input.
	Power Switch Oven Power Relay 20 Minute Time Delay Oven Fan Relay	(SEE MAIN FAN WILL NOT RUN)
	Cooling Fan(s)	Check for 120 VAC at the motor(s). If voltage is present, check motor(s) for shorts, opens, or grounds. If voltage is not present, trace wiring back to Oven Fan Relay. WITH POWER OFF: check for locked rotor.
No automatic control box cooling	Incoming Power Supply	Check circuit breakers, reset if required. Call the Power Company if needed.
	Fuse, Transformer 3A	Check, replace if necessary.
	Fuseholder 1628	Check, replace if necessary
	Transformer, Power 1629 Only	120 VAC +_ 10% should be present at secondary of transformer. If proper voltage is not present, check transformer primary for proper input.
	Cooling Fan Thermostat(s)	Check the cooling fan thermostat(s). (Thermostat closes at 120°F and opens at 100°F) With the cooling fan thermostat pre-heated, check for continuity. If switch is open, replace.
	Cooling Fan (s)	Check for 120 VAC at the motor. If voltage is present, check motor(s) for shorts, opens, or grounds. WITH POWER OFF: check for locked rotor.
Cooling fans continue to run after 20 minute cool down	Cooling Fan Thermostat(s)	Thermostat is normally open and may have closed if control box temperature is 120°F or above.
	Oven Fan Relay	Check to insure contacts are opening after the 20 minute cool down.
Oven will not heat	Incoming Power Supply	Check circuit breakers. Reset if required. Call the Power Company if needed.
	Main Fan(s)	If not operating, Refer to "Oven Fan Will Not Run" Page 13.
	Oven Power Relay	Check for 120 VAC at terminal #2. If no voltage is present, trace wiring back to power supply. Check to insure the contacts are closing.
	Fuse, Temp. Control (3A)	Check, replace if necessary.
	Fuseholder	Check, replace if necessary.

NOTE: These ovens utilize 2 complete heating and temperature control systems. Each system will follow the same trouble shooting sequence.

Low Profile --1600 Series Service Manual – Dom & Int'l	Oven Air Pressure Switch (1628, 1629 only)	Check for 120 VAC on both sides of switch. If voltage is present on one side only, check for air tube blockage. Adjust air switch. If above fails, replace air pressure switch.
	Thermostat, High Limit	Terminals are normally closed. If open, reset and test oven for proper operation. If thermostat will not hold for maximum oven temperature, and oven is not exceeding temperature dial setting, check for proper location of capillary bulb in its spring holder. If above checks okay, replace Hi-Limit thermostat.
	Control Box Cooling Fan	Check to insure the control box cooling fan is operating properly. If the cooling fan is not operating, Refer to "No Control Box Cooling" Page 13.

	Cooling Fan Sail Switch	(NOTE: the cooling fan sail switch is located in front of the cooling fan and is activated by the air flow from the cooling fan.) Check for 120 VAC supply to the sail switch (see Schematic for proper wire numbers). Visually check to see that the sail switch is closing as cooling fan is running, if the sail switch is not closing check for obstructions or damage to the sail switch. Replace as needed.
	Electronic Temperature Control	Check for 120 VAC input to temperature control board. If not present, check wiring from sail switch to temperature control board. Turn the temperature adjustment dial to the maximum temperature position. Check for 120 VAC at coil of mercury contactor(s). Next, short the leads of thermocouple on the temperature control board, check for 120 VAC at coil of mercury contactor(s). If voltage is not present, replace temperature control board. If voltage is present proceed.
	Temperature Control Potentiometer	Potentiometer is 0 to 2.5K ohm. WITH POWER OFF: remove the leads from the temperature control board terminals 1,2, and 3 and measure ohms from black to white leads. The ohm reading should be 0 to approximately 2.5K \pm 5% ohms as the dial is rotated. Check from black, to red leads, the reading should be approximately 2.5K \pm 5% ohms and remain steady throughout the full turn of the temperature control dial. If these readings are not achieved, replace potentiometer.
	Thermocouple Probe	With power on and thermocouple leads attached to the temperature control board, measure the millivolt output of the leads. Refer to chart in adjustment section for proper millivolt readings.
	Mercury Contactor(s)	Check for 120 VAC to the contactor coil. If voltage is present and contactor will not activate, replace the contactor (s). Also check each contactor for proper high voltage input and output.
	50 Amp Fuses	If there is no high voltage input to the mercury contactor(s), check the 50 amp fuses and replace if necessary.
	Heater Elements	Check the Amp draw on each hot leg for proper load. Check the specifications plate for rating information. If the Amp draw is low or high, check the individual elements for opens, shorts, and proper resistance. To check resistance of the elements, TURN OFF THE POWER! Remove all leads from the elements and use an accurate digital VOM. 208V - 25 ohms approx. 220V- 29 ohms approx. 240V - 34 ohms approx. If all readings are not correct, replace elements as needed.
Oven heats with switch off	Mercury Contactor(s)	The mercury contactor has probably malfunctioned in the closed position. If there is no voltage to the operating coil, but there is high voltage at the contactor output, replace the mercury contactor.

Intermittent Heating	Thermal/Overload of Motors	The main fan motors and cooling fan motors are equipped with internal thermal protection and will cease to operate if overheating occurs. As the motors overheat and then cool, this will cause the units to cycle on and off intermittently. Improper ventilation or preventive maintenance may cause this. Also, most of the problems listed under "Oven will not Heat" on Page 21 can cause intermittent failure.
Conveyor will not run	Oven Power Relay	Check to insure that the relay contacts are closed.
	Conveyor Switch	Check for 120 VAC to conveyor switch. If no voltage is present, trace wiring back to the oven power relay. WITH POWER OFF: Check continuity between switch terminals.
	Conveyor Fuse (3A)	Check, replace if necessary.
	Fuseholder	Check, replace if necessary.
	Conveyor Control (Stepper) Transformer	Check for 120 VAC supply to primary of transformer, if voltage is not present, trace wiring back to the fuseholder. If voltage is present, check for output voltage from the transformer secondary NOTE: this control transformer outputs (2) secondary voltages Red Leads 29 VAC Brown Leads 10 VAC If BOTH secondary voltages are not present, replace the transformer.
	Speed Adjustment Potentiometer	This is a 0 to 50K ohm, 10 turn potentiometer. WITH POWER OFF: remove the 3-pin potentiometer cable plug from the motor control board. With a digital multimeter, check the ohm reading across the red lead to the black lead, this reading should be 50K ohms \pm 5% as the potentiometer is rotated through its 10 turn rotation. Place the meter leads on the red lead and white lead. Rotating the potentiometer slowly, from low to high, the meter should show an even transition from 0 to 50K ohms \pm 5% through the 10 turn rotation of the potentiometer. There should be no dead or open spots through the 10 turns of the potentiometer. Check all three leads to ground. There should be no continuity to ground. If any of the above checks fail, replace the potentiometer.
	Conveyor Motor(Stepper) Control	NOTE: if the conveyor drive motor becomes jammed or begins to run at an uncontrolled speed, the conveyor motor will stop running. To reset, turn off the conveyor switch, wait 30 seconds, turn the conveyor switch on. If the motor does not run after attempting re-set, check for 2 to 29 VAC across the motor terminals 1 to 2 and 3 to 5 on the conveyor motor control. If voltage is not present at both sets of terminals, replace control.
Conveyor Drive (Stepper) Motor	Check the drive sprocket on motor output shaft to insure that it is tight. Check motor windings; measurements should be approximately 2 ohms. Terminal 1-5, 2-6, 3-7, 4-8. WITH POWER OFF: Turn the motor shaft to check for jammed gear box. If motor shaft will not turn, replace conveyor drive (Stepper) motor.	

Time/Temp. Display inoperative	12 VAC Power Supply (Transformer)	NOTE: these units utilize (2) complete temperature display systems containing like components. Measure the transformer primary for a nominal 120 VAC input, if voltage is not present, trace wiring back to the oven power relay. Measure the secondary output voltage across terminals 1 and 3 on the time/ temp. display which should read 12-15 VAC. Terminals 1-2 and 2-3 should be 1/2 the voltage reading of 1 to 3. If the above secondary readings are not achieved, check and/or replace transformer.
	Time/Temp. Display	If proper voltage is present at terminals 1,2, and 3 on time/temp. display, but the display is not lighted, recheck all connections for tightness. If time/temp. is still not operating, replace time/temp. display.
Temp. display out or erratic	NOTE: Time/Temp displays use two types of temperature sensors, Thermistor Probe 2 yellow wires, Thermocouple Probe - 1 red wire and 1 white wire.	Connect the thermocouple of a pyrometer to the thermocouple on the temperature control board. (Be sure to maintain proper polarity of thermocouple leads- see Adjustment Section for proper procedure.) The pyrometer will now indicate oven temperature.
	Thermistor Probe	Disconnect the yellow tipped thermistor leads from the time/temp. terminals 9 and 10. Measure the resistance of the thermistor probe. See chart on page 4 for proper resistance reading. Inspect the thermistor bulb for its proper location in its spring holder. Check for short in leads where they enter the sensor bulb. Also check each thermistor lead for short to ground.
	Thermocouple Probe	Measure D.C. millivolts at terminals 9 and 10 on the time/temp display. See thermocouple chart on page 43 for proper readings. Replace thermocouple if proper readings are not achieved. If readings are correct on the thermocouple, replace time/temp display.
	Power Supply	If a strange or unusual behavior is experienced, such as a rolling of numbers, or a lock-up at a given number, first check for a display circuit lock-up. A voltage spike or surge in the incoming power lines may cause this. To eliminate this condition, remove power from the time/ temp. display by shutting off the power switch for 15 seconds. This should eliminate the problem. If this does not solve the problem, it may be coming in through the Commercial power lines. Suggest that customer contact their power company for evaluation.
Temp. display inaccurate, erratic, or inoperative	Time/Temp. Display	Perform the power supply check, inaccurate, erratic, or thermistor probe check, and then perform the time/temp. simulator test. Refer to page 36 & 37 for instructions. Remember, when using the time/temp. simulator, remove all leads from the back of the time/temp. display except the 3 power leads. After completion of the test, and if re- installing time/temp. display back in the oven, the dip switches must be reset for oven operation, and the time/temp. display must be recalibrated. If readings are not achieved, replace display.
	Conveyor Drive (Stepper) Motor	Perform all checks as in the above evaluation. If the time check is okay, refer to the next section. Check to see if the conveyor drive (stepper) motor is running. If motor is not running, refer to "Conveyor Will Not Run" on Page 23.
Time Display inaccurate, erratic, or inoperative		

Magnet	Check to insure that the magnet (cemented to shaft of conveyor drive (stepper) motor) has not been damaged, or come loose from motor shaft. Replace as needed.
Hall Effect Sensor	Check for any physical damage to Hall Effect Sensor (mounted on conveyor drive (stepper) motor). Check all wiring and connections for damage.
Conveyor Drive (Stepper) Control	Check all connections for tightness or proper location and check all wiring for visible damage. Replace as needed. If there is still no time display, wire in (temporarily) a new conveyor drive control. If there is still no time display, reconnect original conveyor drive control. Replace Hall Effect Sensor.

TROUBLESHOOTING / 1646, 1647, 1650, 1651

GAS OVENS

NOTE: When checking components on left side of unit, be sure to check for proper connections in power connector, (marked P.C. on Schematic Diagram.) located inside motor cover.

SYMPTOM	POSSIBLE CAUSE	EVALUATION
Oven fan will not run	Incoming Power Supply	Check breakers/Reset if required/ Call Power Company if needed.
	Transformer Fuse	Check and/or replace
	Fuseholder	Check and/or replace.
	Transformer, Power	120 VAC \pm 10% should be present at secondary of transformer. If proper voltage is not present, check transformer primary for proper input.
	Oven Fan Switch	Check continuity between switch terminals.
	Oven Start Relay	Check for 120 VAC to the relay coil. If voltage is not present, trace wiring back to the oven fan switch. If voltage is present, check to insure contacts are closing.
	20 Minute Time Delay	Check for 120 VAC at terminal #1 to neutral on the 20-minute timer. If no voltage is present, trace wiring back to the power supply. If voltage is present at terminal #1, check for 120 VAC at terminal #2 to neutral. If no voltage is present, and the oven start relay is closed, replace the 20 minute timer.
	Fan Fuse	Check, replace if necessary.
	Fuseholder	Check, replace if necessary.
	Oven Fan Relay	Check for 120 VAC to coil of the oven fan relay. If no voltage is present, trace wiring back to terminal #2 of the 20-minute timer. Check for supply voltage at terminal #4 of the relay, if no voltage is present, trace wiring back to the power supply. If voltage is present at the relay coil, check to insure the contacts are closing.
	Capacitor(s)	Check for opens, shorts, or grounds.
	Motor(s)	Check for opens, shorts, or grounds. WITH POWER OFF: turn the fan blade(s) to check for locked rotor.
No main fan cool down	20 Minute Time Delay	Check for 120 VAC at terminal #2 to neutral while oven is "on". Turn off the main fan switch, 120 VAC should continue to be present for 20 minutes. If voltage is not present for approx. 20 minutes, replace the timer.
	Oven Fan Relay	Check if relay is operating and that the contacts remain closed during the 20 minute cool down.
Main fan runs after 20 minute cool down	Oven Start Relay	Contacts should open when main fan switch is turned off.
	20 Minute Time Delay	120 VAC at terminal #2 should discontinue approximately 20 minutes after main fan is switched off. If the oven start relay contacts are open, and the voltage continues at terminal #2 of the 20-minute timer, replace the timer.
	Oven Fan Relay	Check to insure that the contacts are opening after the coil is de-energized.

No control box cooling	Fan Switch Oven Start Relay 20 Minute Time Delay	(SEE MAIN FAN WILL NOT RUN)
	Cooling Fans	120 VAC should now be at these motors. If voltage is present, check motor for shorts, opens, or grounds. WITH POWER OFF: check for locked rotor.
No automatic control box cooling	Incoming Power Supply	Check circuit breakers, reset if required. Call the Power Company if needed.
	Fuse, Transformer	Check, replace if necessary.
	Fuse Holder	Check, replace if necessary.
	Transformer, Power	120 VAC± 10% should be present at secondary of transformer. If proper voltage is not present, check transformer primary for proper input.
	Cooling Fan Thermostat(s)	Check the cooling fan thermostat. (Thermostat closes at 120°F and opens at 100°F.) With the cooling fan thermostat pre-heated, check for continuity. If switch is open, replace.
	Cooling Fan(s)	120 VAC should now be at these motors. If voltage is motor(s) for shorts, opens, or grounds. WITH POWER OFF: check for locked rotor .
Cooling fans continue to run after 20 minute cool down	Cooling Fan Thermostat(s)	Thermostat is normally open and may have closed if control box temperature is 120°F or above.
Oven will not heat	Gas Supply	Check for adequate gas supply to oven..
	Manual Gas Shut-Off Valve	Check to see that manual shut-off valve is open
	Fan Switch	Check to see that the fan switch is on.
	Main Oven Fan	Check if main oven fan is operating. If not, refer to "Oven fan will not run."

NOTE: These ovens utilize 2 complete Burner/Temperature control systems. Each system will follow the same Troubleshooting Sequence.

	Fuse, Burner 3A	Check, Replace if necessary.
	Fuseholder	Check, Replace if necessary.
	Control Box Cooling Fan	Check to insure the control box cooling fan is operating properly. If the cooling fan is not operating, refer to "No control box cooling" Page 21.
	Cooling Fan Sail Switch	(NOTE: the cooling fan sail switch is located in front of the cooling fan and is activated by the air flow from the cooling fan.) Check for supply voltage to the sail switch (see Schematic for proper wire numbers). Visually check to see that the sail switch is closing as cooling fan is running, if the sail switch is not closing check for obstructions or damage to the sail switch.
	Gas Pressure Switch (internal to gas valve)	Check for supply voltage to neutral on both sides of switch. If voltage is present on one side of switch only, check the following. Check for proper gas pressure supply to gas valve. (Marked on oven spec. plate). Check for proper adjustment of gas pressure switch. Should be set at 8.8 Nat., 23 for L.P., or 4.5 for town gas on dial. Check gas filter in gas valve for blockage or damage. (See Adjustment Section for location). If the above checks okay, but switch is still not closed, replace gas valve.

Oven Air Pressure Switch	Check for supply voltage on both sides of switch. If voltage is present on one side only, check for air tube blockage. Adjust air switch. If above fails, replace air pressure switch.
Hi-Limit Thermostat	Terminals are normally closed. If open, reset and test oven for proper operation. If thermostat will not hold for maximum oven temperature, and oven is not exceeding temperature dial setting, check for proper location of capillary bulb in its spring holder. If above checks okay, replace hi-limit thermostat.
Ignition Control	Check for supply voltage to ignition control at terminal #1 and neutral. If voltage is not present, retrace wiring back to hi-limit thermostat. Check for supply voltage at terminal #6 to neutral. (Power to burner motor). If voltage is present, proceed. If no voltage is present, wait 30 seconds and check reset button. If above fails, replace ignition control.
Burner Reset Switch	Switch is normally open. Check to see that the switch closes when reset button is pushed. Replace as needed.
Burner Blower Motor	Check for supply voltage to burner blower motor. WITH POWER OFF: turn blower wheel to check for locked rotor. If supply voltage is present and motor does not run, replace motor.
Burner Blower Motor Air Pressure Switch	Check for supply voltage switching to terminal "N.O." as the air pressure switch closes. Check for air tube blockage or miss-alignment, adjust air pressure switch. If the above fails, replace air pressure switch.
Spark Generator	After a pre-purge time of 30 to 60 seconds after blower motor starts, check for supply voltage to spark generator. If voltage is not present, check reset button located on rear of control box. If voltage still not present, replace ignition control. If voltage is present, visually check for spark at ignitor head.
Ignitor/Sensor Assembly	Check for visible damage to ignitor/ sensor assembly. If there is no visible damage to the components, and no spark, replace the spark generator. If there is visible damage to the ignitor/ sensor assembly, replace. Also check for frayed or damaged wires in burner tube.
Gas Valve	Check for supply voltage to gas valve. If there is no voltage present, check reset button, check all connections for tightness. If there still is no voltage at gas valve, replace ignition control. If there is voltage present, check for gas pressure at gas pressure tap located in gas piping at Burner manifold. If there is no gas pressure, replace gas valve.
Flame will not stay on	<p>Flame Sensor</p> <p>To check for flame sensor operation, connect a digital multimeter (capable of measuring D.C. micro amps) in series with the flame sensor wire and Ignition Control. Sensor current is 3 micro amps D. C. minimum.</p> <p>NOTE: The D.C. micro amp test must be conducted with the oven in low flame (bypass) operation. Turn the temperature control to its lowest setting. If these readings are not achieved, replace ignitor/sensor assembly. Also check for any type of damage to flame sensor wire and connections.</p>

	Ignition Control	If there is sufficient flame sensor current, but the burner will not remain ignited, check the reset button on ignition control. Note: Check for proper polarity of the power supply. If all above are okay, replace ignition control.
Pilot lamp is on, but no main flame	Temperature Control	Check for 120 VAC across terminals 10 and 11 on temperature control board. If no voltage is present, check wiring back to the Main Fan Switch. Turn the temperature adjustment knob to the maximum temperature position and check for 120 VAC at the load terminal (# 9), and to neutral(#10). If 120 VAC is present and unit is not heating, refer to "Temperature Regulation Valve" for next check. If 120 VAC is not present, proceed.
	Thermocouple Probe	With power on and thermocouple leads attached to board, measure the millivolt output of these leads. Refer to the thermocouple chart in Section D for proper readings.
	Temperature Control Potentiometer	WITH POWER OFF: Remove the potentiometer leads from the temperature control board and measure ohms from black to white leads. The reading should be from approximately 0 to approximately 2.5K ohms as the dial of the potentiometer is turned through its full rotation. From black to red leads, the reading should be approximately 2.5K ohms and remain steady throughout the full rotation of the potentiometer. If the thermocouple probe and the control potentiometer check good, then the problem is usually with the temperature control board.
	Temperature Regulation Valve	If 120 VAC is present on the temperature control board at load terminal to neutral, check for voltage at Temperature regulation valve. If voltage is present, listen for valve to open and close. Also check for opens or shorts in the coil. Replace if required
Intermittent heating	Thermal Overload of Main Fan, Burner Blower and Cooling Fan Motors	The Main Fan Motors the Burner Blower Motors and cooling fan motors are equipped with internal thermal protection and will cease to operate if overheating occurs. As the motors overheat and then cool, this will cause the units to cycle on and off intermittently. This may be caused by improper ventilation or preventive maintenance. Also, most of the problems listed under "Oven Will Not Heat" can cause intermittent failure.
Conveyor will not run	Conveyor Switch	Check for 120 VAC to conveyor switch. If no voltage is trace wiring back to the power supply. WITH POWER OFF: Check continuity between switch terminals.
	Conveyor Fuse (3A)	Check, replace if necessary.
	Fuseholder	Check, replace if necessary.
	Conveyor Control (Stepper) Transformer	Check for 120 VAC supply to primary of transformer, if voltage is not present, trace wiring back to the fuseholder. If voltage is present check for output voltage from the transformer secondary NOTE: this control transformer outputs (2) secondary voltage Red Leads 29 VAC Brown Leads 10 VAC If BOTH secondary voltages are not present, replace the transformer.

Speed Adjustment Potentiometer	This is a 0 to 50k ohm, 10 turn potentiometer. WITH POWER OFF: remove the 3-pin potentiometer cable plug from the motor control board. With a digital multimeter, check the ohm reading across the red lead to the black lead, this reading should be 50k ohms \pm 5% as the potentiometer is rotated through its 10 turn rotation. Place the meter leads on the red lead and white lead. Rotating the potentiometer slowly, from low to high, the meter should show an even transition from 0 to 50k ohms \pm 5% through the 10 turn rotation of the potentiometer. There should be no dead or open spots through the 10 turns of the potentiometer. Check all three leads to ground. There should be no continuity to ground. If any of the above checks fail, replace the potentiometer.
Conveyor Motor (Stepper) Control	NOTE: if the conveyor drive motor becomes jammed or begins to run at an uncontrolled speed, the conveyor motor will stop running. To reset, turn off the conveyor switch, wait 30 seconds, turn the conveyor switch on. If the motor does not run after attempting re-set, check for 2 to 29 VAC across the motor terminals 1 to 2 and 3 to 5 on the conveyor motor control. If voltage is not present at both sets of terminals, replace control.
Conveyor Drive (Stepper) Motor	Check the drive sprocket on motor out- put shaft to insure that it is tight. WITH POWER OFF: Turn the motor shaft to check for jammed gear box. Check motor windings ohm readings on motor terminals. 1-5, 2-6, 3-7, 4-8, each reading should be approx. 2 ohms. If motor shaft will not turn, replace conveyor drive (stepper) motor.

NOTE: These units utilize (2) complete Temperature Display systems containing like components.

Time/Temp. Display inoperative	12 VAC Power Supply (Transformer)	Measure the transformer primary for a nominal 120 VAC input, if voltage is not present, trace wiring back to the oven fan switch. Measure the secondary output, which will normally be 12-15 VAC. Voltage across terminals 1 and 3 on the time/temp. display should read 12-15 VAC. Terminals 1-2 and 2-3 should be 1/2 the voltage reading 1 to 3. If the above secondary readings are not achieved, replace transformer.
	Time/Temp. Display	If proper voltage is present at terminals 1, 2, and 3 on time/temp. display, but the display is not lighted, recheck all connections for tightness. If time/temp. display is still not operating, replace the time/temp. display .
Temp. Display out or inaccurate	NOTE: Time/Temp displays uses two types of temperature sensors, Thermistor Probe – 2 yellow wires, Thermocouple Probe - 1 red wire and 1 white wire	Connect the thermocouple of a pyrometer to the thermocouple on the temperature control board. (Be sure to maintain proper polarity of thermocouple leads-see Adjustment Section for proper procedure.) The pyrometer will now indicate oven temperature.

	Thermistor Probe	Disconnect the yellow tipped thermistor leads from the time/temp terminals 9 and 10. Measure the resistance of the thermistor probe. See chart in Section D for proper resistance readings. Inspect the thermistor bulb for its proper location in its spring holder. Check for short in leads where they enter the sensor bulb. Also check each thermistor lead for short to ground.
	Thermocouple Probe	Measure D.C. millivolts at terminals 9 and 10 on the time/temp display. See thermocouple chart in Section D for proper readings. Replace thermocouple if proper readings are not achieved. If readings are correct on the thermocouple, replace time/temp display.
	Power Supply	If a strange or unusual behavior is experienced, such as a rolling of numbers, or lock-up at a given numbers, first check for a display circuit lock-up. A voltage spike or surge in the incoming power lines may cause this. To eliminate this condition, remove power from the time/temp. display by shutting off the main fan switch for 15 seconds. This should eliminate the problem. If this does not solve the problem, it may be coming in through the Commercial power lines. Suggest that customer contact their power company for evaluation.
Temp. display inaccurate, erratic, or inoperative	Time/Temp. Display	Perform the power supply check, the thermistor probe check, and then perform the time/temp. simulator test. Refer to Section D for instructions. Remember, when using the time/temp. simulator, remove all leads from the back of the time/temp. display except the 3 power leads. After completion of the test, and if re-installing time/temp. display back in the oven, the dip switches must be reset for oven operation, and the time/temp. display must be recalibrated. If readings are not achieved, replace display.
Time Display inaccurate, erratic, or inoperative		Perform all checks as in the above evaluation. If the time check is okay, refer to the next section.
	Conveyor Drive(Stepper) Motor	Check to see if the conveyor drive (stepper) motor is running. If motor is not running, refer to "Conveyor will not run" on Page 23
	Magnet	Check to insure that the magnet (cemented to shaft of conveyor drive [stepper] motor) has not been damaged, or come loose from motor shaft. Replace as needed.
	Hall Effect Sensor	Check for any physical damage to Hall Effect sensor (mounted on conveyor drive [stepper] motor). Check all wiring and connections for damage.
	Conveyor Drive (Stepper) Control	Check all connections for tightness or proper location and check all wiring for visible damage. Replace as needed. If there is still no time display. Wire in (temporarily) a new conveyor drive control. If there is still no time display, reconnect original conveyor drive control. Replace Hall Effect Sensor.

REMOVAL, INSTALLATION & ADJUSTMENTS

MODEL SERIES 1600

CAUTION !

BEFORE REMOVING OR INSTALLING ANY COMPONENT IN THE IMPINGER OVEN BE SURE TO DISCONNECT ELECTRICAL POWER AND GAS SUPPLY

SAIL SWITCH, COOLING FAN - REPLACEMENT

- A. Remove conveyor.
- B. Remove appropriate control box cover - Front.
- C. Remove two (2) wires from switch assy. note wire number and location.
- D. Remove switch assy.
- E. Reassemble in reverse order and check system operation.

BURNER CONTROL - HONEYWELL - REPLACEMENT

- A. Remove conveyor.
- B. Remove appropriate control box cover - Front.
- C. Remove wires from control, note wire number and location for reassembly.
- D. Remove four(4) screws from control and replace.
- E. Reassemble in reverse order and check system operation.

BURNER BLOWER MOTOR - REPLACEMENT

- A. Remove appropriate control box cover - Rear.
- B. Unplug motor connector.
- C. Remove three (3) screws from blower tube at burner housing.
- D. Remove air shutter assy. from old motor for installation on new motor assy.
- E. Reassemble in reverse order and check system operation.

NOTE: CHECK AIR SHUTTER ADJUSTMENT- Should be set at 1/2 open.

HOT SURFACE IGNITER - REPLACEMENT

- A. Remove appropriate control box cover - Rear.
- B. Remove pipe union.
- C. Remove four (4) nuts from burner orifice bracket.
- D. Remove tube for bypass flame.
- E. Unplug connector at burner housing.
- F. Remove three (3) screws from burner housing end cap and remove hot surface igniter and burner tube assy. Replace igniter assembly and reassemble in reverse order. CAUTION: USE CARE NOT TO DAMAGE NEW IGNITER.

NOTE: Check all gas line fittings for leaks. Make sure connector is seated properly.

BURNER INDICATOR LIGHT (GAS) - REPLACEMENT HEAT INDICATOR LIGHT (ELECTRIC)

- A. Remove conveyor.
- B. Remove control box cover - Front.
- C. Remove two (2) wires from light housing.
- D. Slide light housing sideways to remove.
- E. Reassemble in reverse order and check system operation.

CONVEYOR CONTROL POTENTIOMETER (50K OHM) - REPLACEMENT

- A. Remove conveyor.
- B. Remove control box cover - Front.
- C. Loosen two (2) allen screws and remove knob by sliding off shaft.
- D. Remove shaft lock from potentiometer shaft and push out.
- E. Unplug wire connector from conveyor control board.
- F. Reassemble in reverse order and check system operation.

NOTE: Install the shaft lock on the speed pot shaft so the threads go on first. THIS IS A TIGHT FITTING COLLAR DO NOT DRILL OUT THE HOLE. Slide the collar down the shaft and screw it onto the mounting threads. Install the knob on the shaft and tighten the set screws. Before re-installing the control box cover, check the operation of the speed pot through its full range to insure that the shaft lock doesn't come loose.

- G. Recalibrate conveyor control board.

20 MINUTE TIMER (COOL DOWN) - REPLACEMENT

- A. Remove conveyor.
- B. Remove control box cover - Front.
- C. Remove four (4) wires, note wire numbers and location for reinstallation.
- D. Remove one (1) hold down screw and replace timer.
- E. Reassemble in reverse order and check system operation.

CONVEYOR CONTROL BOARD - REPLACEMENT AND CALIBRATION

- A. Remove conveyor.
- B. Remove control box cover - Front.
- C. Remove three (3) screws from control assembly.
- D. Disconnect wiring (Push on connectors) from control board.
NOTE: Proper location of connectors for reinstallation.
- E. Reassemble in reverse order and check system operation.
- F. Recalibrate conveyor control board.

- 1. With power off, the five (5) dip switches located on the conveyor control (see drawing, next page) should be set as listed.

DIP SWITCHES

CONTROL	1	2	3	4	5
SWITCH POSITION	OFF	OFF	ON	OFF	OFF

- 2. With power off, the ten (10) dip switches located on rear of Time/Temp Display (see drawing on page 38) should be set (See Below)

NOTE: For time/temp displays using a thermistor probe (2 yellow wires in terminals 9 and 10, set dip switches as follows.

DISPLAY	1	2	3	4	5	6	7	8	9	10
SWITCH POSITION	OFF	*	*	ON	OFF	OFF	ON	ON	OFF	ON

*SWITCH 2 - OFF FOR 60HZ, ON FOR 50 HZ
SWITCH 3 - OFF FOR °F, ON FOR ° C

For time/temp displays using a thermocouple (red wire on #9 and white wire on #10), set the dip switches as follows:

DISPLAY	1	2	3	4	5	6	7	8	9	10
SWITCH POSITION	OFF	OFF	*	ON	OFF	OFF	ON	ON	OFF	ON

*OFF for °F *ON for °C

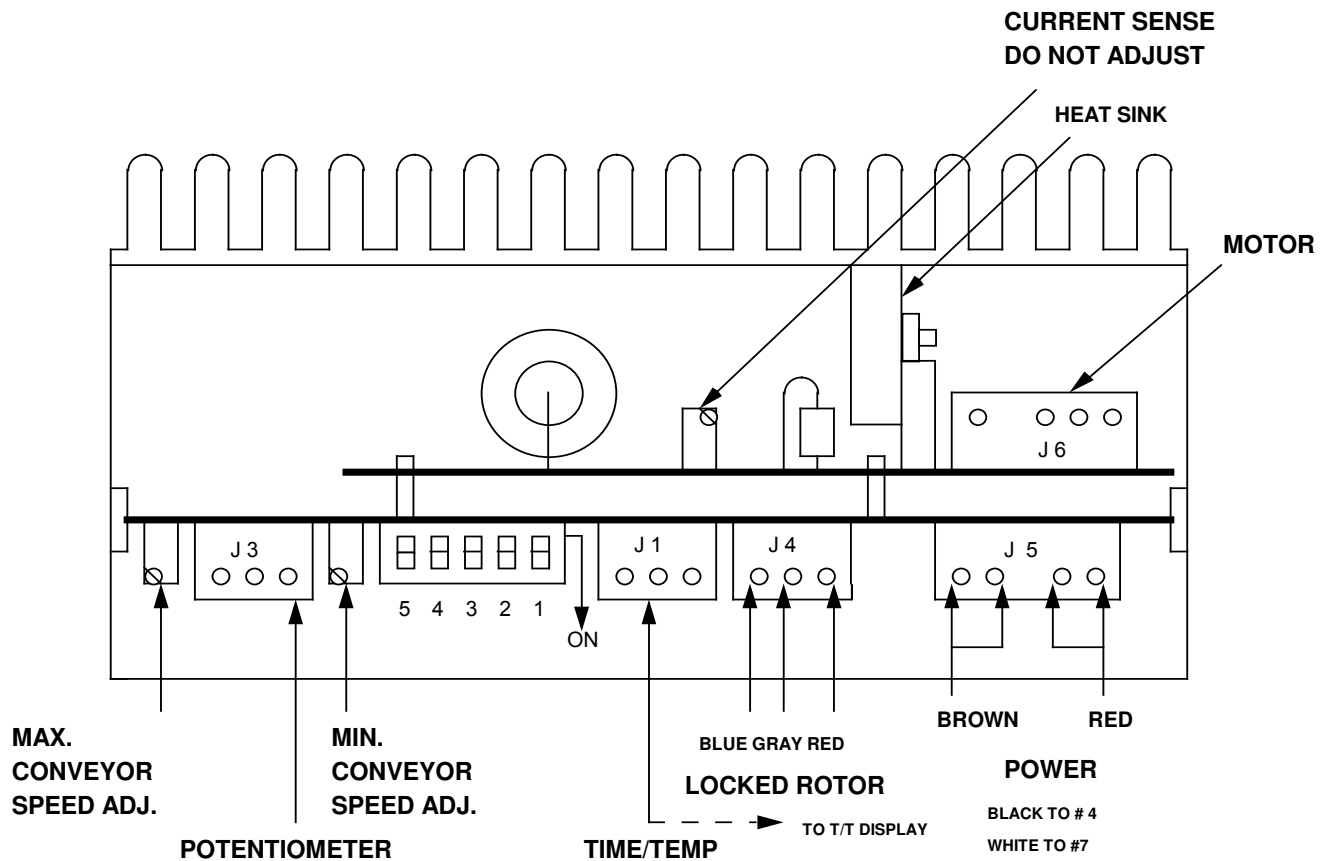

- With conveyor running, set conveyor speed control so Time/Temp. Display indicates 5:00 minutes. Place a pan on the conveyor, measure (STOPWATCH) the time (SPEED OF PAN) of the leading edge in to leading edge out of oven. Turn the time adjustment pot. on the rear of the Time/Temp. Display so display agrees with time measured by the stop watch. (See drawing on Page 38)
- Turn conveyor speed control fully counterclockwise and adjust the stepper control maximum speed pot (refer to drawing above) so the display indicates 50 seconds.
- Turn conveyor speed control fully clockwise and adjust the stepper control minimum speed pot so the display indicates 30 minutes.

NOTE: Repeat 4 and 5 to be sure settings are accurate.

- Turn power off and set #1 dip switch to the (ON/OFF) other position and verify that the conveyor reverses direction when power is applied. Set conveyor travel direction as customer requests.

CAUTION: ALWAYS REMOVE POWER BEFORE CHANGING CONVEYOR DIRECTION.

FUSEHOLDER - REPLACEMENT

- Remove control box cover - Rear.
- Remove two (2) wires, note wire number and location.
- Remove locknut on back side of fuseholder and push out.
- Reinstall in reverse order and check system operation.

GAS VALVE, DUAL SAFETY - REPLACEMENT

- A. Remove appropriate control box cover - Rear.
- B. Remove incoming gas line.
- C. Remove screws from incoming nipple mounting bracket.
- D. Remove incoming nipple.
- E. Remove bypass tube assy.
- F. Disconnect pipe union.
- G. Disconnect wiring from control valve (four [4] push on connectors), make note of wire numbers and location for reinstallation.
- H. Remove gas piping from old valve and install on new one.
- I. Reassemble in reverse order and check system operation. Set manifold pressure on gas valve. Pressure should be 3.5 in W.C. Nat., 10 in W.C. L.P., and 2.0 in W.C. Town Gas. NOTE: Check all gas line fittings for leaks, check and adjust manifold pressure.

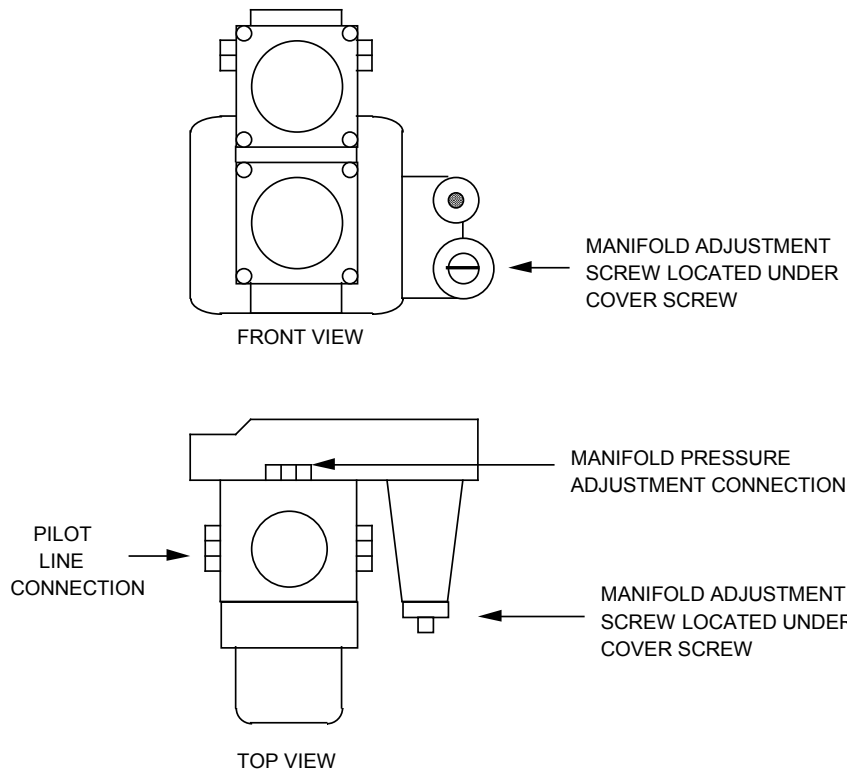

TEMPERATURE REGULATING VALVE - REPLACEMENT

- A. Remove appropriate control box cover - Rear.
- B. Remove bypass tube assy.
- C. Remove four (4) nuts from burner orifice bracket.
- D. Disconnect pipe union.
- E. Disconnect two (2) wires from valve and remove assembly.
- F. Remove gas piping from old valve and install on new one.
- G. Reassemble in reverse order and check system operation. NOTE: Check all gas line fittings for leaks and insure valve gas flow is in proper direction .

MAIN ORIFICE - REPLACEMENT

- A. Remove appropriate control box cover - Rear.
 - B. Remove bypass tube assembly.
 - C. Remove four (4) nuts from burner orifice bracket.
 - D. Disconnect pipe union.
 - E. Remove assembly and replace main orifice.
 - F. Reassemble in reverse order and check system operation.
- NOTE: Check all gas line fittings for leaks.

TEMPERATURE CONTROL POTENTIOMETER - REPLACEMENT

- A. Remove conveyor.
- B. Remove control box cover - Front.
- C. Loosen screw and slide knob off potentiometer shaft.
- D. Remove locknut and push out.
- E. Remove three (3) wires from electronic temperature control, note wire color and location for reinstallation.
- F. Reassemble in reverse order and check system operation.

ON-OFF SWITCH (POWER/CONVEYOR) - REPLACEMENT

- A. Remove conveyor.
 - B. Remove control box cover - Front.
 - C. Depress spring clips on side of switch and push out.
 - D. Remove wires from back of switch, note wire number and location.
 - E. Reassemble in reverse order and check system operation.
- NOTE: Make sure switch housing is fully seated in control box housing.

DUAL TIME/TEMPERATURE DISPLAY - REPLACEMENT

- A. Remove conveyor.
- B. Remove control box cover - Front.
- C. Remove wires from terminal strips on back of assembly (5 wires on top 7 wires on bottom), note wire location for reinstallation.
- D. Remove two (2) screws from display case and remove display.
- E. Reassemble in reverse order. (Make sure all wires are properly seated and secure in terminal strip.) Check system operation and calibrate (Insure that dip switches are properly set.)
- F. Apply power to unit and perform the following checks: Check for color and intensity match on displays and colons. Observe for display stability
- G. (NOTE: At temperature below 150°F "LLL" should be illuminated on the temperature display section). Adjust the conveyor speed control knob to effect a large change in motor speed and observe display response. (NOTE: Display updates will lag the induced change by approx. 3 seconds.)

CALIBRATE TEMPERATURE

- A. (See Page 37 for connection of Temperature Sensor.) Set Temp. Control to 500°F. Allow temperature to stabilize.
- B. "Fine Tune" temperature setting to achieve measured temperature swings from 497°F to 503°F. When actual temperature falls between 497°F and 503°F, the display must show 500°F.
- C. Adjust temperature calibration pot on Time/Temp Display to achieve a display reading of 500°F (260°C). NOTE: D, E, and F are for displays with thermistor probe only.
- D. Reset the temperature control to maximum and allow temperature to stabilize.
- E. Observe displayed number and compare to actual monitored temperature; if displayed temperature is within 5°F (5°C) of actual, calibration is complete.
- F. If displayed temperature is in error by 10°F (10°C) or more then set the high

temperature adjustment pot to achieve a displayed temperature equal to the actual temperature.

- G. Reset temperature control to 500°F and repeat Steps B and C to complete calibration; seal adjustment pots with Glyptol or nail polish.

CALIBRATE TIME

- A. Activate conveyor and set display time to 10 minutes (NOTE: In setting time, make small adjustments in conveyor speed and observe the time display; allow 3-5 seconds for the display to stabilize before effecting further changes in belt speed).
- B. Place an object on the conveyor belt and time with a stopwatch the elapsed time for the object to travel through the oven (Leading edge in to leading edge out).
- C. If actual time is not within 5 seconds, adjust the time calibration pot to update time display to match the measured time.
- D. Time calibration completed; seal adjustment pot with Glyptol or nail polish.

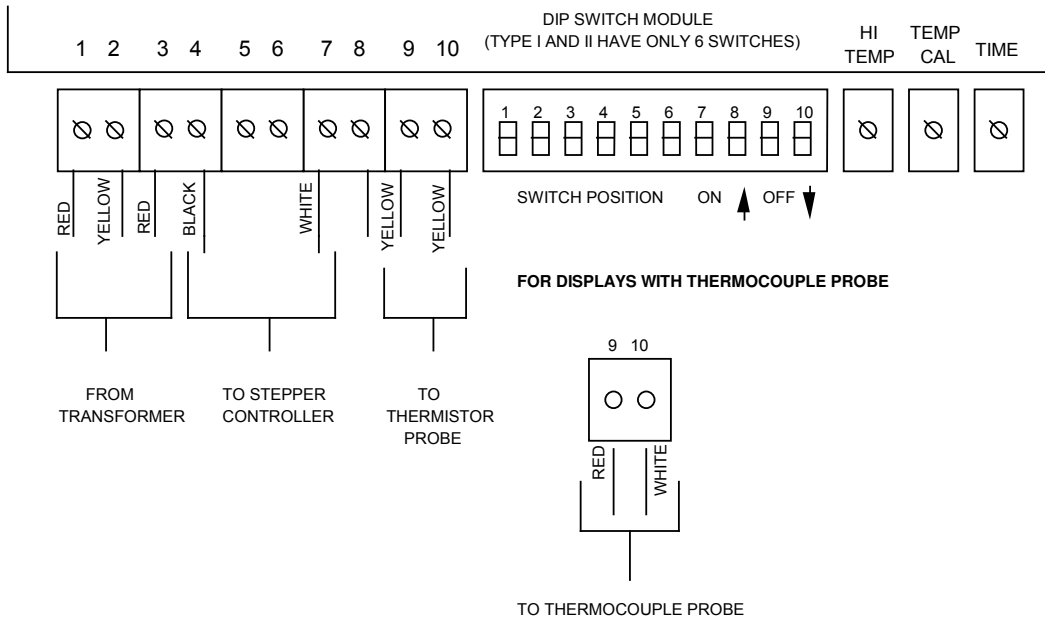

PROCEDURE FOR USE OF TIME/TEMP. SIMULATOR

NOTE: For displays with Thermocouple, simulator will not work.

DO NOT CHANGE HI TEMP POT

- A. Check incoming power to display at Terminals 1, 2, and 3. Approx. 13 VAC at 1-3, 6.5 VAC at 1-2, 6.5 VAC at 2-3.
- B. With power OFF, remove all leads except 1,2, and 3. Install Time/Temp. Simulator to Terminals 4, 7, 9, 10.
- C. To set dip switches:

Dip Switch

1	2	3	4	5	6	7	8	9	10
off	off	off	off	off	off	off	on	off	on

With power ON turn time and temp. cal. pot. fully counterclockwise.

Display should read: (Wait 15-20 seconds) 9:35 ± 10 sec. 635°F ± 10°F

- D. Turn time and temp. cal. pot. fully clockwise.
- E. Display should read: (Wait 15-20 seconds) 10:20 ± 10 sec. 475°F ± 10°F
- F. Turn time pot to 10:00 minutes and temp. pot. to 540°F.
Time reading 10:00 ± 5 seconds.
- G. Temperature reading should be steady at 540°F ± 10°F.
- H. If these readings are not achieved, replace display.

For displays with thermistor probe--continue.

If temperature is still inaccurate after above calibration and troubleshooting, use the following to check the High Temp. Pot. normally the High Temp. Pot. does not require adjustment. Occasionally the pot. is accidentally moved or needs adjustment. Refer to the following proper adjustment of the High Temp. Pot.

FOR DISPLAYS WITH THERMISTOR PROBE ONLY

BOTTOM OF TIME TEMP DISPLAY

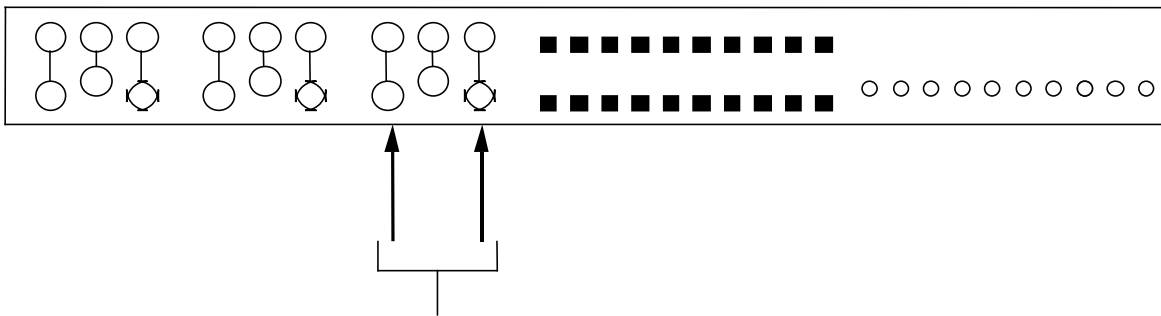

test leads here
reading should be 26 ± .5 ohms if not, adjust.
pot. range 0-34 ohms

DUAL TIME/TEMPERATURE DISPLAY - DIP SWITCH SETTING

- A. Before applying power to unit, check all connections for proper tightness and connections.
- B. Check and set dip switch programming to match the application as outlined below.
- C. Check connections and speed pot connections at stepper motor and board.

<u>SWITCH</u>	<u>MEANING/POSITION</u>
1	Switch Off
2 Thermistor	Switch Off for 60 HZ/switch on for 50 HZ
2 Thermocouple	Off

3 Switch Off for °F/switch on for °C
 4-10 See programming chart

NOTE: If dip switches 3 through 10 are turned on, the display will show all eight's / i.e. (88:88:888). This is for checking display.

MOTOR PROGRAMMING CHART

TIME TEMP POS.	DIP SWITCH							
	4	5	6	7	8	9	10	
TOP	OFF	OFF	OFF	OFF	OFF	OFF	OFF	
BOTTOM	ON	OFF	OFF	ON	ON	OFF	ON	

TRANSFORMER-TIME/TEMPERATURE DISPLAY - REPLACEMENT

- A. Remove conveyor.
- B. Remove control box cover - Front.
- C. Remove five (5) wires (2 primary side, 3 secondary side), note color and location of wires for reinstallation.
- D. Remove two(2) screws from transformer base and replace assembly.
- E. Reassemble in reverse order and check system operation.

BURNER CONTROL TRANSFORMER - REPLACEMENT

- A. Remove conveyor.
- B. Remove appropriate control box cover- Front.
- C. Remove two (2) wires on primary side, note color and location.
- D. Remove two (2) wires on secondary side at burner control (Honeywell).
- E. Remove two (2) screws from transformer base and replace assembly.
- F. Reinstall in reverse order and check system operation

CONVEYOR CONTROL TRANSFORMER - REPLACEMENT

- A. Remove conveyor.
- B. Remove control box cover - Front.
- C. Remove two (2) wires on primary side, note color and location.
- D. Remove four (4) wires on secondary side by unplugging connector at conveyor control board.
- E. Remove two (2) screws from transformer base and replace assembly.
- F. Reinstall in reverse order and check system operation.

CAPACITOR, MAIN FAN MOTOR (7.5 MFD/370V) - REPLACEMENT

- A. Remove conveyor.
- B. Remove appropriate control box cover - Front.
- C. Remove two (2) wires from capacitor, note wire number and location.
 WARNING: Capacitor has a stored charge, discharge before handling or testing.
- D. Cut two (2) tie raps securing capacitor to base and replace.
- E. Reinstall in reverse order and check system operation.

RELAY (OVEN POWER, FAN, BURNER & CONVEYOR)- REPLACEMENT

- A. Remove conveyor.
- B. Remove control box cover - Front.
- C. Identify correct relay and remove six (6) wires, note wire numbers and location for reinstallation.
- D. Remove two (2) screws from relay base and replace relay.
- E. Reassemble in reverse order making sure wire connectors are properly seated.
- F. Check system operation.

THERMOSTAT, COOLING FAN - REPLACEMENT

- A. Remove conveyor.
- B. Remove appropriate control box cover - Front.

- C. Remove two (2) wires from thermostat, note wire number and location.
- D. Remove two (2) mounting screws and replace thermostat.
- E. Reassemble in reverse order and check system operation.

MERCURY CONTACTOR

- A. Shut off power at main breaker.
- B. Remove appropriate control box cover-rear.
- C. Disconnect contactor wires and mark for reinstallation.
- D. Remove screws from mounting bracket and replace contactor.
- NOTE:** Be sure contactor is not mounted upside down as this will cause a constant on condition.
- E. Reassemble in reverse order.

ELECTRONIC TEMPERATURE CONTROL - REPLACEMENT

- A. Remove conveyor.
- B. Remove control box cover - Front.
- C. Identify correct control and remove eight (8) wires.
- NOTE:** Potentiometer leads are color coded red, white, and black, note location for reinstallation. Thermocouple leads are red and white (terminal #6 is white + and terminal #7 is red-), note location; do not reverse polarity.
- D. Remove two (2) mounting screws and replace control.
- E. Reassemble in reverse order and check system operation.

TEMPERATURE SETTING FOR NEW TEMPERATURE CONTROL BOARD

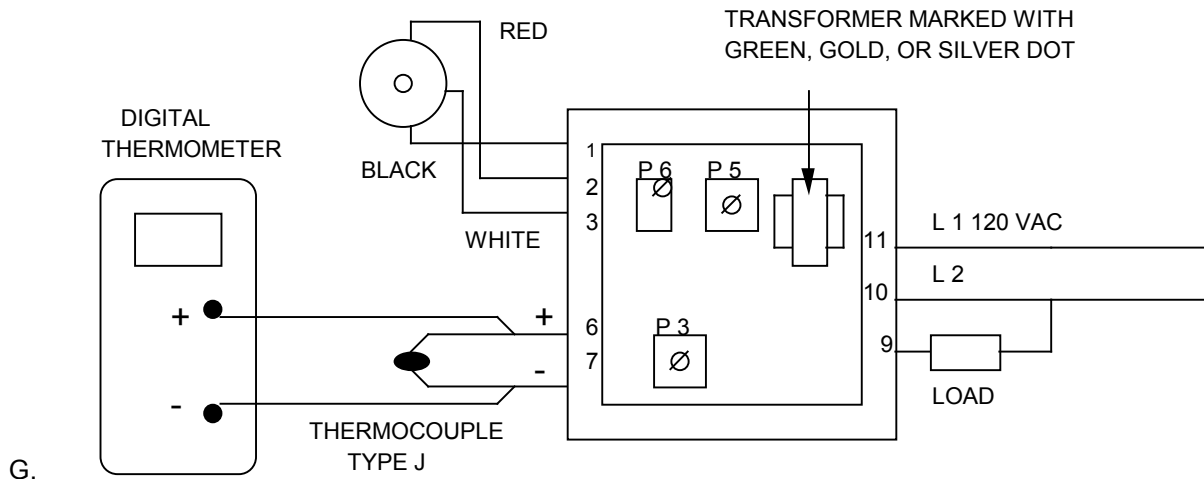

PROCEDURE FOR SETTING MAXIMUM TEMPERATURE POTENTIOMETER (P6)

NOTE: When replacing P/N [369728](#), turn oven temperature control to its maximum heat position and allow 30 minute preheat before calibrating. Connect temperature probe to the oven thermocouple leads at the temperature control board and adjust potentiometer P6 to a maximum temperature of 600°F (315°C). (See Diagram Above)

HIGH LIMIT THERMOSTAT - REPLACEMENT

- A. Remove appropriate control box cover - front
- B. Remove appropriate control box cover - rear
- C. Remove conveyor and fingers.
- D. Remove capillary bulb from wire form in oven chamber and pull through tube into control box.
- E. Remove two (2) wires from thermostat, note wire numbers and location for reinstallation.
- F. Remove screws from bracket and remove thermostat.
- G. Reassemble in reverse order making sure capillary tube is placed securely in the wire form.
- NOTE:** Depress reset button to insure thermostat is set for operation.

HEATING ELEMENT - REPLACEMENT

- A. Shut off power at main breaker.
 - B. Remove appropriate control box cover - rear.
 - C. Disconnect heater element wire and mark for reassembly.
 - D. Remove two (2) mounting screws and remove heating element.
 - E. Reassemble in reverse order.
- NOTE:** Be sure that leading edge of heating element is located in heating element mounting bracket located in oven cavity.

COOLING FAN MOTOR - REPLACEMENT

- A. Remove conveyor.
 - B. Remove appropriate control box cover - Front.
 - C. Remove appropriate control box cover - Rear.
 - D. Remove three (3) screws along control box wall.
 - E. Unplug electrical connector and remove fan motor assembly.
 - F. Reassemble in reverse order and check system operation.
- NOTE:** Cooling fan motors for left and right control box are internally wired to run in opposite directions and are not interchangeable.

MAIN FAN MOTOR - REPLACEMENT

- A. Shut off gas supply and remove gas line and manifold lines from back of oven.
 - B. Remove screws from motor cover housing and lift off.
- NOTE:** When ovens are stacked, all motor cover housings are fastened together.
- C. Unplug power connector.
 - D. Unplug thermocouple and thermistor connectors.
 - E. Unplug two (2) motor connectors.
 - F. Remove eight (8) bolts from oven back (4 left, 4 right) and lift out.
 - G. Remove one (1) screw from fan hub and slide fan blade off of motor shaft.
(Note location of fan blade for reinstallation).S/N 15183 & Below
 - H. Remove hose clamp from around motor. Loosen bolts on motor support legs and swing out of the way. Remove four (4) hex head screws from motor mount bracket and remove fan motor from back housing.
 - I. Remove motor mount from motor and reinstall on new motor.
 - J. Reassemble in reverse order.
S/N 15184 & Above
 - K. Loosen locknuts on cone. Remove two mounting bolts and remove motor from back assy.
 - L. Remove four (4) hex head screws from motor mount bracket.
Remove motor mount from motor and reinstall on new motor.
 - M. Reassemble in reverse order.
- NOTE:**
- 1. Make sure motor is centered in back housing.
 - 2. Verify correct location of fan blade and that it is not hitting fan shroud.
 - 3. Make sure all connectors are properly seated and making good contact.
 - 4. When reinstalling gas manifold across back of oven, check all fittings for leaks.
- N. Check system operation (allow 30 minute preheat for all checks).
- NOTE:** Position of the fan on the motor shaft will be 1.875" from the top of the oven back cone to the blade spider assembly on the fan hub. (See drawing below.)

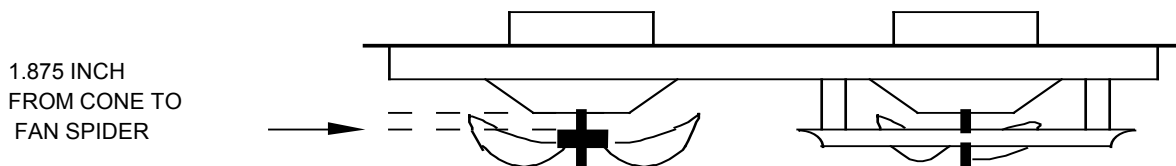

THERMOCOUPLE (TYPE J) - REPLACEMENT

- A. Remove conveyor.
- B. Remove bottom fingers.

- C. Remove appropriate control box covers (Front & Rear).
NOTE: For ovens serial number L21545 and above, the oven back must be removed to replace the thermocouple.
- D. Remove thermocouple from wire form in oven chamber and remove from chamber. NOTE: R. H. Thermocouple (viewed from front) is connected directly to the temperature control board, remove two (2) wires, make note of wire colors (terminal #6 is White + and terminal #7 is Red-) and location for reinstallation. When changing L.H. Thermocouple (viewed from front), the back motor cover must also be removed to gain access to the thermocouple connector plug.
- E. Reassemble in reverse order making sure bulb is placed securely in the wire form in the oven chamber.
- F. Check system operation, recalibrate as needed. NOTE: The R.H. and L.H. Thermocouples have different connectors on the wire ends and must be ordered accordingly.

INFORMATION:

When two wires composed of dissimilar metals are joined together and one of the ends is heated, a continuous current flow is generated. We use an iron constant (Type J) thermocouple. The iron wire increases the number of dissimilar junctions in the circuit.

It is possible to check a thermocouple with a properly calibrated D.C. millivolt meter. At 32°F, the millivolt reading should be 0.00. This can be checked by inserting the thermocouple into an ice bath.

The millivolt reading at 72°F should be 1.134.

When using the following chart, the temperature at the terminal connections must be noted. This temperature is call the Junction Temperature.

The following chart lists the thermocouple millivolt readings from 200°F to 600°F.

		O V E N T E M P										
		200°F	250°F	300°F	325°F	350°F	400°F	425°F	450°F	500°F	550°F	600°F
J U N C T I O N	90°F	3.26	4.77	6.30	7.06	7.83	9.37	10.14	10.91	12.46	14.00	15.53
	88°F	3.32	4.83	6.36	7.12	7.89	9.43	10.20	10.97	12.51	14.05	15.59
	86°F	3.37	4.88	6.41	7.17	7.94	9.49	10.26	11.03	12.57	14.11	15.65
	84°F	3.43	4.94	6.47	7.23	8.00	9.54	10.31	11.09	12.63	14.19	15.71
	82°F	3.49	5.00	6.53	7.29	8.06	9.60	10.37	11.14	12.69	14.23	15.76
	80°F	3.55	5.06	6.59	7.35	8.12	9.66	10.43	11.20	12.74	14.28	15.82
	78°F	3.60	5.11	6.64	7.40	8.17	9.72	10.49	11.26	12.80	14.34	15.86
	76°F	3.66	5.17	6.70	7.46	8.23	9.77	10.55	11.32	12.86	14.40	15.94
	75°F	3.69	5.20	6.73	7.49	8.26	9.80	10.57	11.35	12.89	14.43	15.97
	74°F	3.72	5.23	6.76	7.52	8.29	9.83	10.60	11.37	12.92	14.46	15.99
T E M P	72°F	3.78	5.29	6.82	7.58	8.35	9.89	10.66	11.43	12.97	14.51	16.05
	70°F	3.83	5.34	6.87	7.63	8.40	9.95	10.72	11.49	13.03	14.57	16.11
	68°F	3.89	5.40	6.93	7.69	8.46	10.00	10.78	11.55	13.09	14.63	16.17
	66°F	3.95	5.46	6.99	7.75	8.52	10.06	10.83	11.61	13.15	14.69	16.23
	64°F	4.01	5.52	7.05	7.81	8.58	10.12	10.89	11.66	13.20	14.74	16.28
	62°F	4.06	5.57	7.10	7.86	8.63	10.18	10.95	11.72	13.26	14.80	16.34
	60°F	4.12	5.63	7.16	7.92	8.69	10.24	11.01	11.78	13.32	14.86	16.40

OVEN TEMPERATURE

	300°F	325°F	350°F	400°F	425°F	450°	500°F	550°F
OHMS	182	138	102	62	48	38	24	16

THERMISTOR, 10K OHM - REPLACEMENT

- Remove conveyor.
- Remove bottom fingers.
- Remove appropriate control box covers - Front & Rear.
- Remove thermistor probe from wire form in oven chamber and remove from chamber.
NOTE: R. H. Thermistor (viewed from front) is connected directly to the Time/Temp. Display (Bottom, #9 & #10). When changing L. H. Thermistor (viewed from front), the back motor cover must also be removed to gain access to the thermistor connector plug.
- Reassemble in reverse order, making sure bulb is placed securely in the wire form in the oven chamber.
- Check system operation, recalibrate as needed.

INFORMATION:

With the oven set at 500°F and your pyrometer reading the same, check the thermistor as follows:

- Disconnect the two yellow thermistor leads, position #9 and #10, from the terminal strip on the back side of the time/temp. display. **NOTE:** When the thermistor is disconnected, the display should show "LLL".
- Take an ohm reading across the thermistor leads. At a setting of 500°F, the reading should be 24 to 25 ohms. When checking the reading at 550°F, the reading should be 16 ohms. If the readings can not be attained, replace the thermistor. If the readings are present, then replace the time/temp. display.

HALL EFFECT SENSOR - REPLACEMENT

NOTE: There are two (2) styles of hall effect sensors - (See drawing below).

- Remove conveyor.
- Remove control box cover - Front & Rear
- Remove three (3) wire connector from conveyor control board. Old Style
- Remove two (2) screws from conveyor drive motor and break away hall effect sensor from around motor shaft.
- To install new sensor, cut sensor bracket through center hole and install sensor half with one (1) screw. New Style

- F. Remove two (2) mounting screws and remove sensor from conveyor motor.
- G. Reinstall plug on conveyor control and check conveyor system operation. Recalibrate as needed.
- H. Replace control box covers and check system operation.

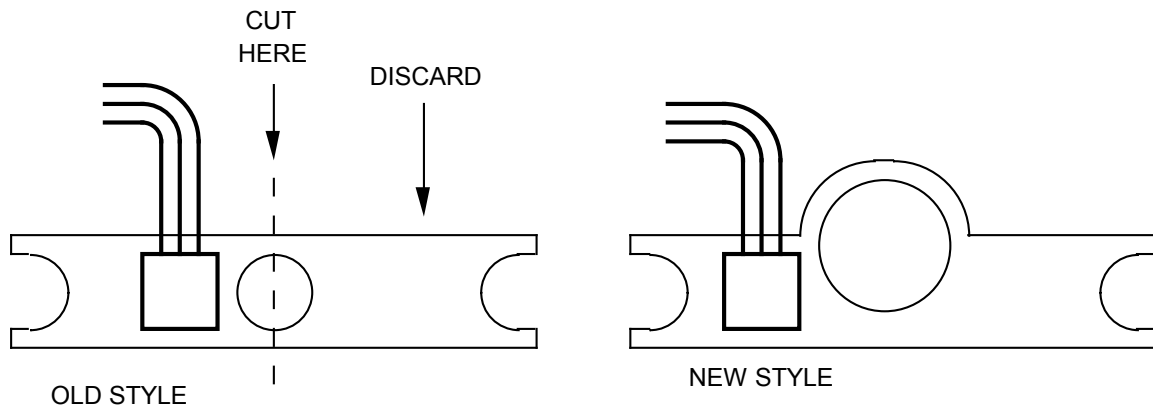

CONVEYOR DRIVE MOTOR - REPLACEMENT

- A. Remove conveyor.
- B. Remove control box cover - Front and Rear.
- C. Loosen set screw on conveyor drive sprocket and slide sprocket off shaft.
- D. Disconnect motor plug and wiring for Hall Effect Sensor.
- E. Remove four (4) screws from motor frame, on control box side, and remove motor assembly.
- F. Reassemble in reverse order making sure to align chain sprockets and adjust motor for proper chain tension (1/2" SAG).

NOTE: New drive motors will come as an assembly with Magnet and Hall Effect Sensor. The magnet and sensor are available as replaceable spare parts. (When replacing the magnet, be sure to clean shaft and locate new magnet up against the shoulder on shaft.)

BEARING, CONVEYOR - REPLACEMENT

- A. Remove conveyor from oven and place on a flat work surface.
- B. Remove connecting links from conveyor belting. See Installation and Operating Instructions Manual.
- C. Remove conveyor belting from conveyor.

DRIVE END

- D. Remove drive sprocket from drive shaft.
- E. Remove two (2) allen head bolts.
- F. Remove drive shaft and bearing assembly from conveyor frame.
- G. Reassemble in reverse order.
- H. Apply silicone sealant to bolt heads.

IDLER END

- I. Remove idler shaft/bearing/mounting plate assembly from conveyor frame.
- J. Remove bearing/mounting plate assembly from conveyor.
- K. Remove bearing from mounting plate.
- L. Reassemble in reverse order.

THE FOLLOWING ITEMS ARE USED IN THE MODEL 1646,1647, 1650 & 1651 IMPINGER OVEN

AIR PRESSURE SWITCH - REPLACEMENT AND ADJUSTMENT

- A. Remove appropriate control box cover - rear.
 - B. Disconnect wires from switch making note of wire number and location for reinstallation.
 - C. Remove air tube from switch assembly.
 - D. Remove switch from hanger.
 - E. Install new switch in reverse order, make sure air tube is not blocked or misaligned. Adjust as needed.
- To adjust the air pressure switch, remove snap on cover on the side of the switch to expose adjusting screw. To increase sensitivity, turn screw counter clockwise; to decrease sensitivity, turn screw clockwise. Check for proper line voltage switching from N.C. to N.O. as the air pressure switch closes.

GAS VALVE - REPLACEMENT AND ADJUSTMENTS

- A. Remove appropriate control box cover - rear.
- B. Disconnect the gas piping from the back of the unit.
- C. Remove the four (4) screws from the incoming nipple-mounting bracket.
- D. Remove incoming nipple.
- E. Disconnect two (2) plugs, (1) 3 prong and (1) 4 prong - Note location.
- F. Disconnect pipe union just above gas valve and remove assembly.
- G. Reassemble in reverse order (check all pipe fittings for leaks). After assembled, check for proper adjustment of gas pressure switch, 8.8 on dial for natural gas, 23 for L.P. Gas, and 4.5 for town gas.
- H. Check and adjust manifold pressure. Remove pressure tap located in gas piping above the gas valve prior to the burner orifice and install manometer. Adjustment screw is located on the front of the valve, remove plastic cap and adjust as needed: 3.5" WC for Natural Gas, 10" WC for L.P., and 2.0" WC for Town gas.
- I. Check gas filter by removing cover plate (located on either side of valve). Remove four(4) screws and slide filter out of valve housing and inspect. Reassemble in reverse order and check for leaks around cover.

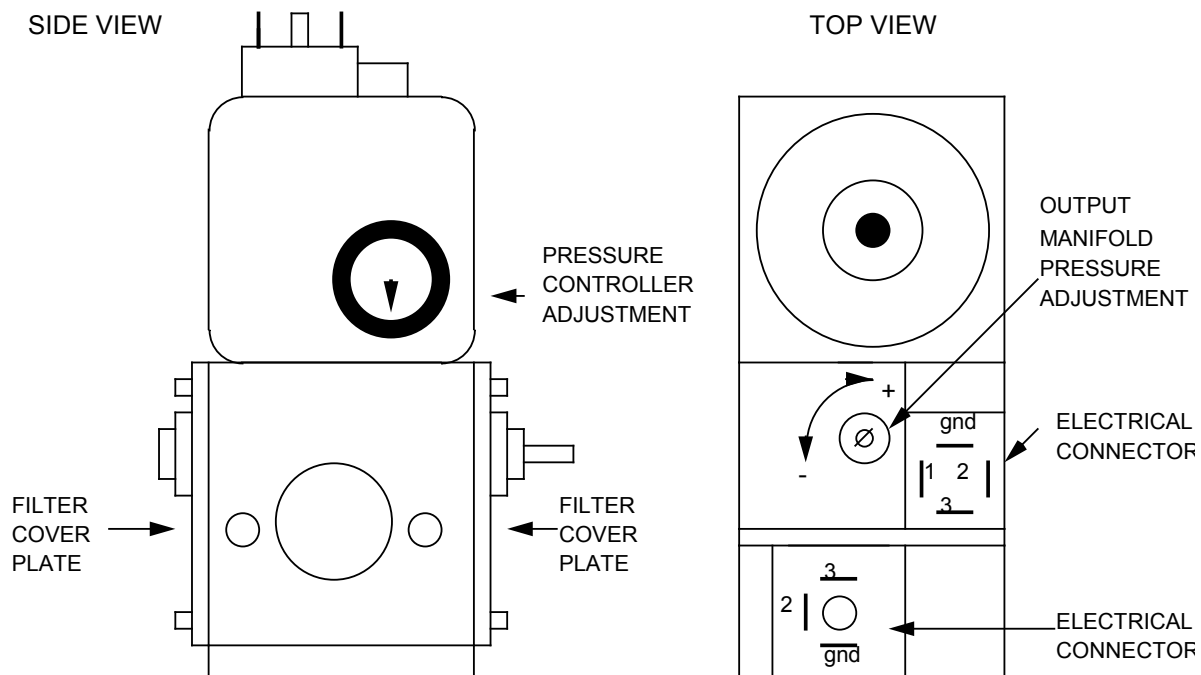

BURNER ALARM - REPLACEMENT

- A. Remove appropriate control box cover - rear.

- B. Remove two (2) wires from alarm, note wire numbers and location.
- C. Remove retainer cover from alarm and remove assembly from control box.
- D. Reassemble in reverse order and check operation.

SPARK GENERATOR - REPLACEMENT

- A. Remove appropriate control box cover - rear.
- B. Remove two (2) wires for spark generator.
- C. Unplug connector on bottom of spark generator.
- D. Remove two (2) mounting screws and remove generator assembly.
- E. Reassemble in reverse order and check system operation.

IGNITION CONTROL - REPLACEMENT

- A. Remove appropriate control box cover - rear.
- B. Remove front portion of relay by releasing tabs on side pulling straight out (rocking motion).
- C. Remove wires from plug-in terminal strip, note wire numbers and location.
- D. Remove two(2) screws from mounting bracket and remove.
- E. Reassemble in reverse order. Check system operation.

IGNITER SENSOR ASSEMBLY - REPLACEMENT

- A. Remove appropriate control box cover - rear.
- B. Remove gas valve assembly (See Gas Valve).
- C. Remove screws from burner tube and pull burner assembly out.
- D. Remove wire connectors from igniter sensor assembly.
- E. Remove screws from mounting bracket and remove assembly.
- F. Reassemble in reverse order and check system operation.

NOTE: After installation, check all pipe fittings for leaks.

This page intentionally left blank.

PARTS / GENERAL - 1600 SERIES

LETTER	PART	DESCRIPTION
A	369708	Drive Chain Cover
B	369781	Cover, Right Rear (Gas)
	370057	Cover, Right Rear (Electric)
C	369782	Cover, Right Front-S/N 16837 & Below
	369789	Cover, Right Front-S/N 16838 & Above
D	369745	Hinge Assy., Right
E	369723	Door Assy., Small
F	369783	Latch, Spring
G	369328	Leg
H	369030	Caster, High Stand
	369390	Caster, Low Stand
J	369501	Latch
K	369717	Finger Retaining Bracket
L	369712	Finger Housing, Left Hand
	369711	Finger Housing, Right Hand
M		Columnating Plate - See Installation & Operations Manual
N	369707	Finger Cover
O	369057	Screw, Finger Retaining Bracket
P	369740	Handle Assy.
Q	369718	Door Assy., Large
R	369746	Hinge Assy., Left Hand
S	369741	Window Retainer, Left S/N 17825 & Below
	369929	Retainer, Window S/N 17826 & Above
T	369762	Access Window, Bottom S/N 17825 & Below
	369926	Window Frame, Bottom S/N 17826 & Above
U	369722	Window Frame, Top S/N 17825 & Below
	369927	Window Frame, Top S/N 17826 & Above
V	369721	Dowel, Access Door S/N 17825 & Below
	369928	Dowel, Access Door S/N 17826 & Above
X	369742	Window, Retainer, Right S/N 17825 & Below
	369929	Retainer, Window S/N 17826 & Above
Y	369739	Glass, Access Door S/N 17825 & Below
	369925	Glass, Access Window S/N 17826 & Above
Z	369784	Cover, Left Front-S/N 16837 & Below
	369790	Cover, Left Front-S/N 16838 & Above
AA	369785	Cover, Left Rear (Gas)
	370056	Cover, Left Rear (Electric)
BB	1609	Oven Top
CC	370090	Stand off, Control Box (Electric)
DD	369911	Control Panel, Right
EE	369913	Label, Control Panel, Right
FF	369239	Label, Finger Plate
GG	370088	Label, Instruction
HH	369914	Label, Control Panel, Left
JJ	369912	Control Panel, Left

BLOW UP / GENERAL – 1600 SERIES

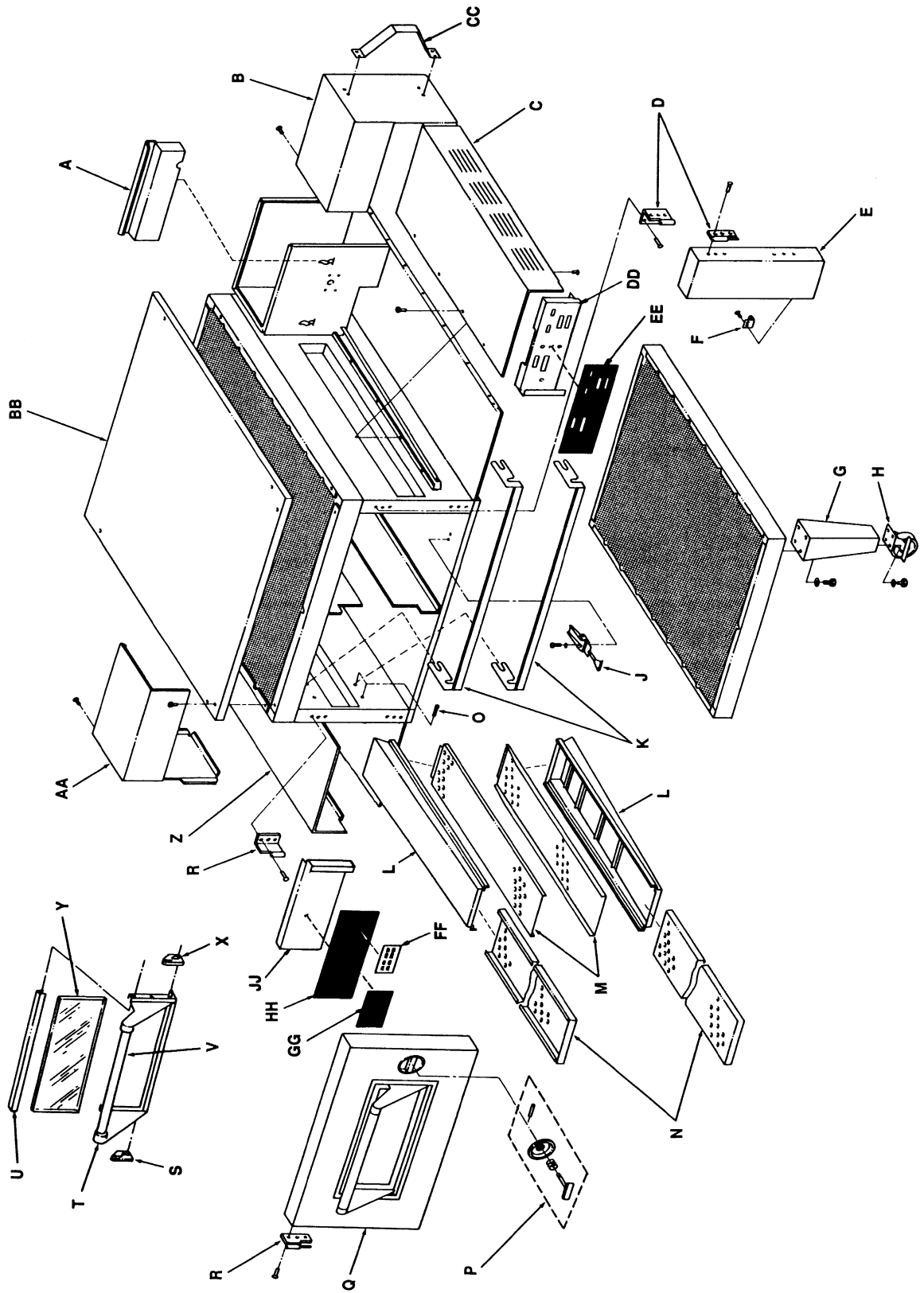

PARTS / CONTROL BOX, RIGHT- 1600 - 1601 - 1652

LETTER	PART #	DESCRIPTION
A	369173	Transformer, Time/Temp. Display
B	369189	Terminal Block, 4-Pole
C	369728	Temperature Control
D	369192	Capacitor
E	369531	Transformer 24 VAC, Burner
F	369605	Transformer, Stepper Control
G	369703	Blower Motor, Right Hand
H	369640	Control, Stepper
J	369603	Motor, Gear Box Assembly (Includes K & L)
K	369737	Hall Effect Sensor
L	369736	Magnet
M	369538	Strain Relief
N	369556	Orifice, Bypass - Natural - 1600
	369557	Orifice, Bypass - L. P.- 1601
	370054	Bypass Orifice - 1652
O	369263	Gas Control Valve - Natural/LP
P	369398	Solenoid Valve
Q	369924	Power Cord
R	369757	Orifice, Main - Natural - 1600
	369758	Orifice, Main - L.P. - 1601
	370055	Main Orifice - 1652
S	369552	Hot Surface Igniter
T	369366	Burner Blower Motor
U	369401	Air Shutter Assy.
V	369012	Fuse Holder
	369013	Fuse, 3A (NOT SHOWN)
	369014	Fuse, 10A (NOT SHOWN)
W	369066	Sprocket
X	369735	Thermistor
Y	369705	Thermocouple, Right Hand
Z	369376	Terminal Block, 3 Pole
AA	369508	Timer, 20 Minute
BB	369523	Relay
CC	369532	Ignition Control
DD	369738	Sail Switch Assy.
EE	369260	Switch
FF	357036	Knob (Temperature Control)
GG	369248	Knob
HH	369247	Shaft Lock
JJ	350225	Lens, Red
KK	369704	Time/Temp. Display
LL	369104	Pilot Light
MM	369520	Potentiometer (Temperature Control)
NN	369391	Potentiometer (Conveyor Control)
OO	369507	Thermostat, Cooling Fan
PP	369747	Stand Off

BLOW UP / CONTROL BOX RIGHT – 1600, 1601, 1652

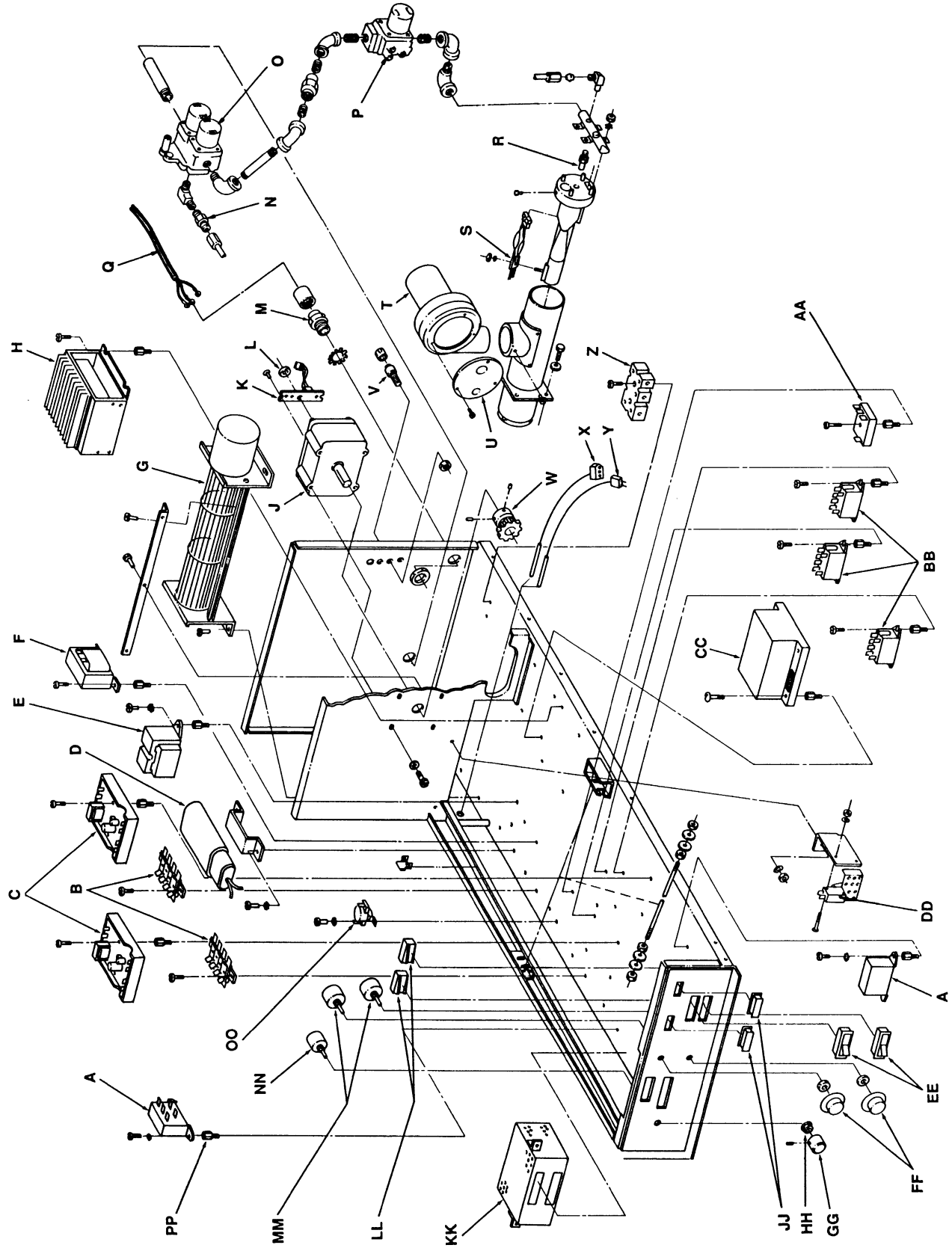

PARTS / CONTROL BOX, LEFT - 1600 - 1601 - 1652

LETTER	PART #	DESCRIPTION
A	369702	Blower Motor, Left Hand
B	369531	Transformer 24 VAC, Burner
C	369747	Stand-Off
D	369192	Capacitor
E	369507	Thermostat, Cooling Fan
F	369738	Sail Switch Assy.
G	369532	Ignition Control
H	369706	Thermocouple Assy., Left Hand
J	369735	Thermistor Assy., Left Hand
K	369401	Air Shutter Assy.
L	369366	Burner Blower Motor
M	369552	Hot Surface Igniter
N	369757	Main Burner Orifice - Natural, 1600
	369758	Main Burner Orifice - L.P. 1601
	370055	Main Orifice, 1652
P	369398	Solenoid Valve
Q	369263	Gas Control Valve - Natural/L.P.
R	369556	Bypass Orifice - Natural, 1600
	369557	Bypass Orifice - L.P., 1601
	370054	By Pass Orifice, 1652
S	369012	Fuse Holder
	369013	Fuse, 3A (NOT SHOWN)
	369014	Fuse, 10A (NOT SHOWN)

BLOW UP / CONTROL BOX LEFT – 1600, 1601, 1652

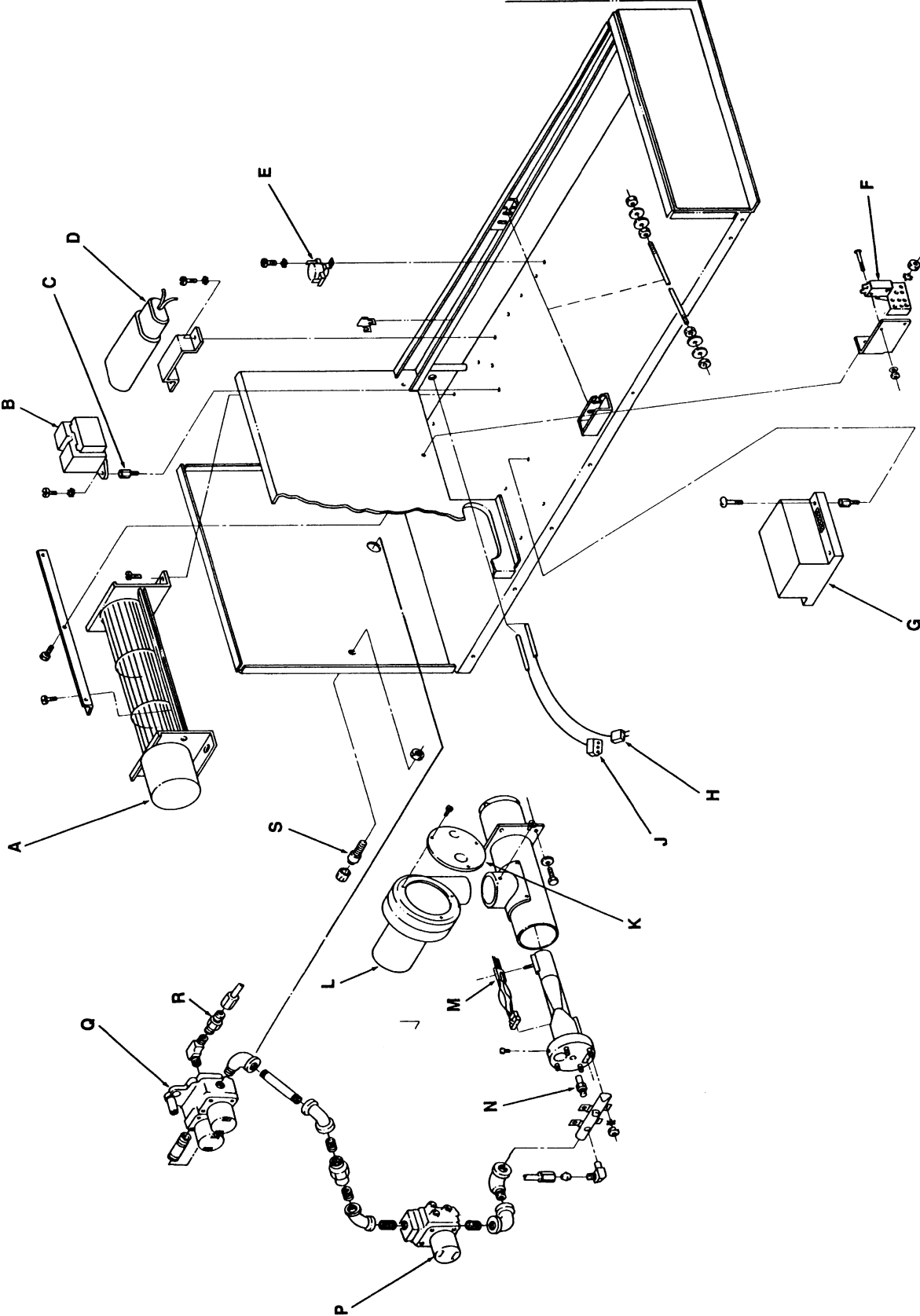

PARTS / CONTROL BOX, RIGHT –1622,1623,1628,1629

LETTER	PART #	DESCRIPTION
A	369704	Time/Temp. Display
B	369128	Pilot Light 125V
C	369520	Potentiometer (Temp. Control)
D	369391	Potentiometer (Conveyor Control)
E	369173	Transformer, Time/Temp. Display
F	369507	Thermostat, Cooling Fan
G	369192	Capacitor
H	369189	Terminal Block, 4-Pole
J	369728	Temperature Control
K	369134	Fuse, 50A.
L	369119	Fuseholder
M	369605	Transformer, Stepper Control
N	357067	Thermostat, Hi-Limit
O	369066	Sprocket
P	369603	Motor, Gear Box Assy. (Includes Q & R)
Q	369737	Hall Effect Sensor
R	369736	Magnet (2 Pole)
S	369772	Terminal Block
T	369013	Fuse 3A. (AGC3)
	369014	Fuse 10A. (MDL10) (1628,1629)
	369166	Fuse 10A. (SC10) (1622,1623)
	369012	Fuseholder (3A-1622,1623)
	369129	Fuseholder (10A-1622,1623)
	357107	Fuseholder (1628,1629)
U	369765	Heating Element, Top 208V, Red
	369766	Heating Element, Top 220V, Yellow
	369768	Heating Element, Top 24-V, Blue
V	369302	Contact, 50A, 120V
W	369703	Blower Motor, Right Hand
X	369118	Power Terminal Block
Y	369764	Heating Element, Bottom, 208V, Red
	369767	Heating Element, Bottom, 220V, Yellow
	369769	Heating Element, Bottom, 240V, Blue
Z	369735	Thermistor
AA	369705	Thermocouple, Right Hand
BB	369640	Control, Stepper
CC	354258	Transformer, Power (1628,1629)
DD	369508	Time Delay, 20 Minute
EE	369523	Relay
FF	369738	Sail Switch Assy.
GG	369260	Switch, On/Off
HH	357036	Knob, (Temperature Control)
JJ	369248	Knob
KK	369247	Shaft Lock
LL	350225	Lens, Red (1622,1623)
	350224	Lens, Yellow (1628,1629)
MM	369575	Air Pressure Switch (1628,1629)

BLOW UP / CONTROL BOX RIGHT – 1622,1623,1628,1629

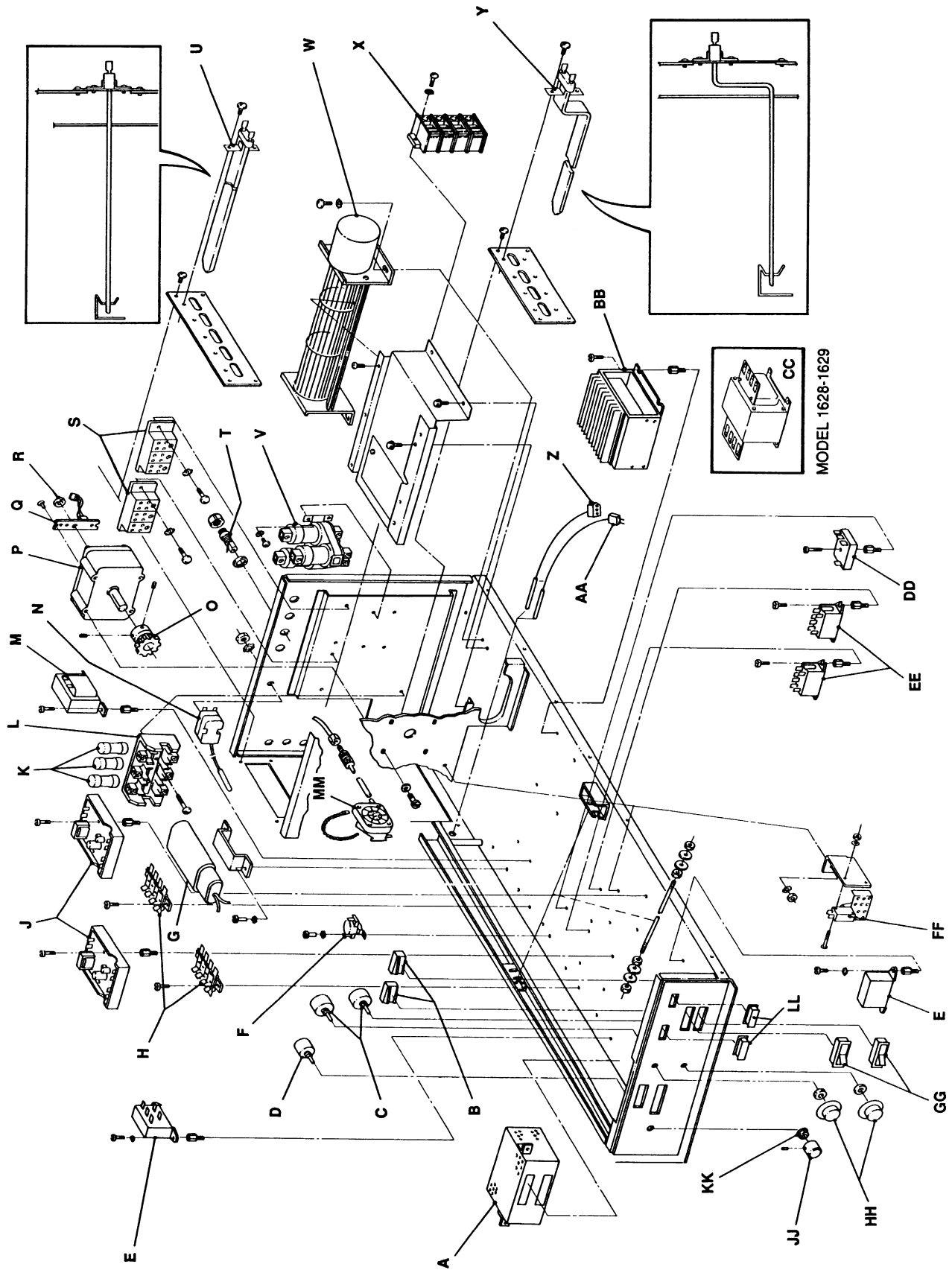

MODEL 1628-1629

PARTS / CONTROL BOX, LEFT 1622,1623,1628,1629

LETTER	PART #	DESCRIPTION
A	369134	Fuse, 50A.
B	369119	Fuseholder
C	369706	Thermocouple Assy., Left Hand
D	369735	Thermistor Assy., Left Hand
E	369764	Heating Element, Bottom 208V, Red
	369767	Heating Element, Bottom 220V, Yellow
	369769	Heating Element, Bottom 240V, Blue
F	369765	Heating Element, Top 208V, Red
	369766	Heating Element, Top 220V, Yellow
	369768	Heating Element, Top 240V, Blue
G	369702	Blower Motor, Left Hand
H	357067	Thermostat, Hi-Limit
J	369772	Terminal Block
K	369302	Contacto, Mercury
L	369192	Capacitor
M	369507	Thermostat, Cooling Fan
N	369738	Sail Switch Assy.
O	369575	Air Pressure Switch (1628,1629)

BLOW UP / CONTROL BOX LEFT – 1622, 1623, 1628, 1629

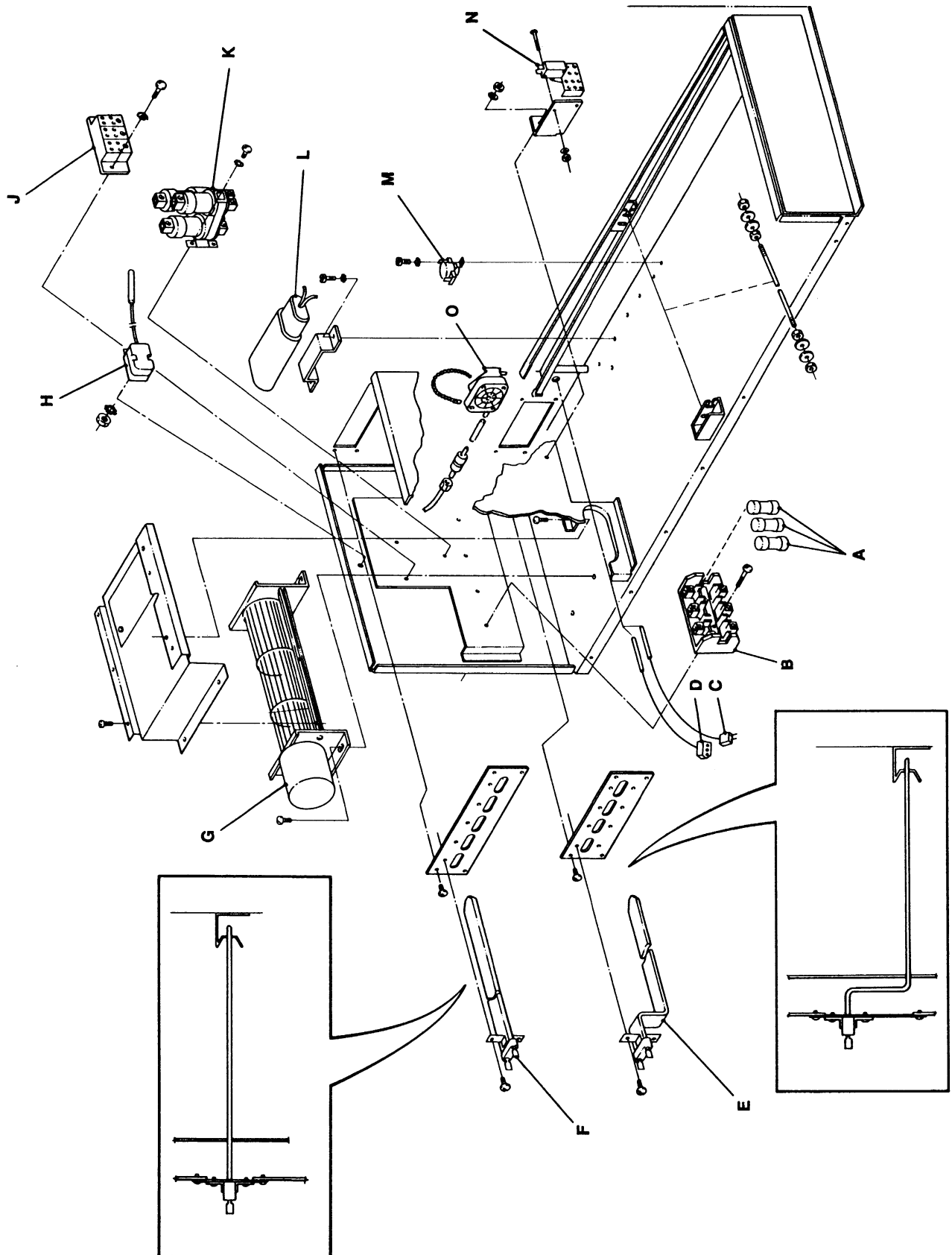

PARTS / CONTROL BOX RIGHT – 1646, 1647, 1650, 1651

LETTER	PART #	DESCRIPTION
A	369248	Knob
B	369247	Shaft Lock
C	350224	Lens, Yellow
D	369704	Time/Temp. Display
E	369467	Light, Burner
F	369520	Potentiometer(Temperature Control)
G	369391	Potentiometer (Conveyor Control)
H	369507	Thermostat, Cooling Fan
J	369579	Alarm, Burner
K	369173	Transformer, Time/Temp. Display
L	369189	Terminal Block, 4-Pole
M	369192	Capacitor
N	369728	Temperature Control
O	369575	Air Pressure Switch
P	369786	Chain
Q	369605	Transformer, Stepper Control
R	369573	Ignition Control
S	369066	Sprocket
T	369603	Motor, Gear Box Assy (Includes U & V)
U	369737	Hall Effect Sensor
V	369736	Magnet
W	369771	Switch, Burner Reset
X	369368	Thermostat, Hi-Limit
Y	357107	Fuseholder
Z	369013	Fuse, 3A
	369014	Fuse, 10A
AA	369085	Junction Box
BB	369376	Terminal Block, 3-Pole
CC	369589	Burner Blower Motor
DD	369580	Gas Valve, Multi-Block
EE	369571	Connector, 4-Pole
FF	369570	Connector, 3-Pole
GG	369556	Orifice By-Pass, 1646
	369557	Orifice By-Pass, 1647
	370053	Orifice, By-Pass, 1650, 1651
HH	369398	Solenoid Valve
JJ	369757	Main Burner Orifice - 1646
	369758	Main Burner Orifice - 1647
	370052	Main Burner Orifice - 1650
	370051	Main Burner Orifice - 1651
KK	369689	Pressure Tap Fitting
LL	369937	Burner Venturi & End Cap, 1646 Only
	369773	Burner Venturi & End Cap, 1647 Only
MM	369590	Igniter Sensor Assy.
NN	369401	Air Shutter Assy.
OO	369574	Spark Generator
PP	369703	Blower Motor, Right Hand
QQ	354258	Transformer, Control
RR	369640	Control, Stepper
SS	369747	Stand-Off
TT	369735	Thermistor
UU	369705	Thermocouple, Right Hand
VV	369508	Timer, 20 Minute
WW	369523	Relay
XX	369738	Sail Switch Assy.
YY	369260	Switch, On/Off
ZZ	357036	Knob (Temperature Control)

BLOW UP / CONTROL BOX RIGHT – 1646,1647,1650,1651

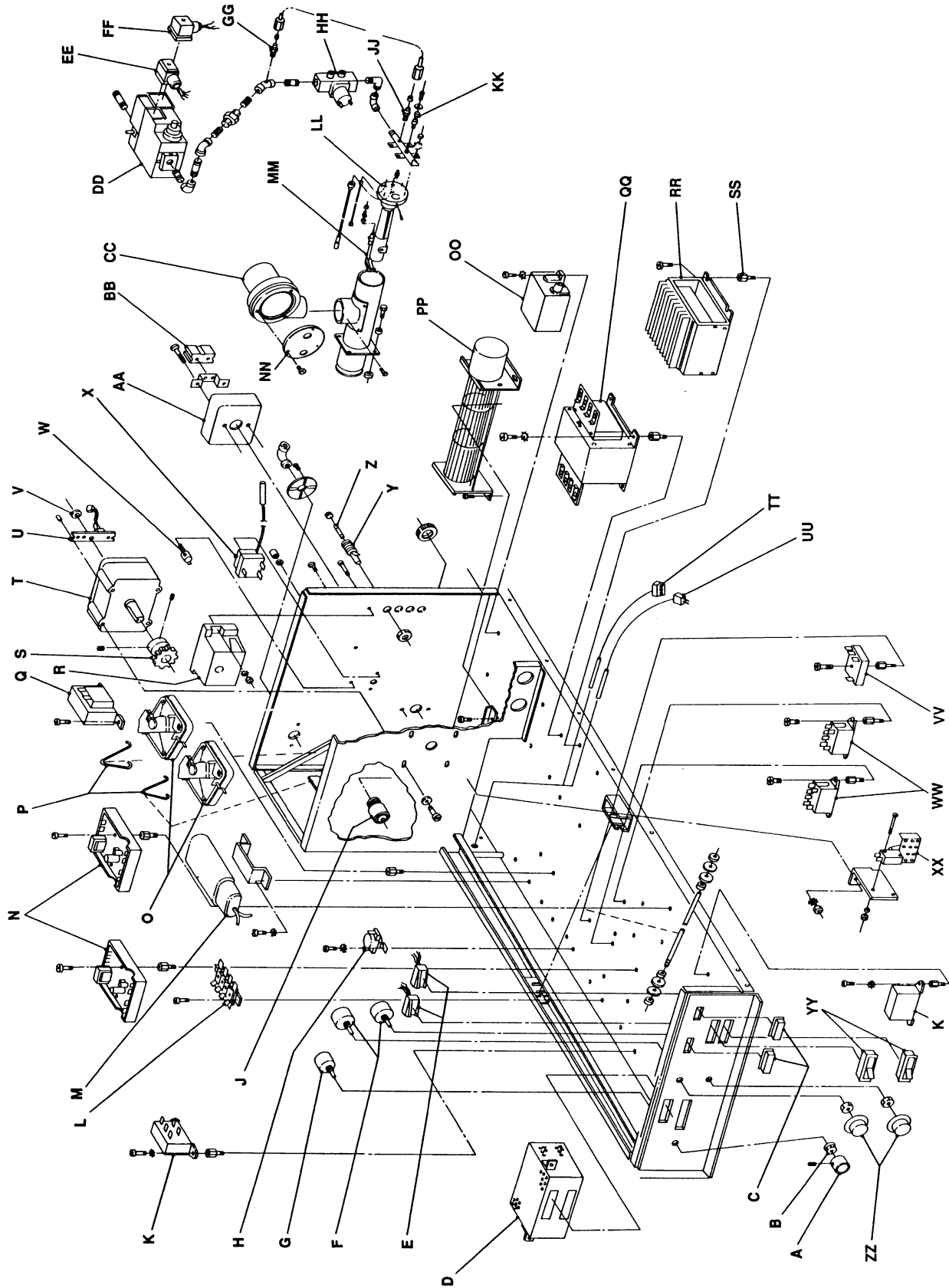

PARTS / CONTROL BOX LEFT – 1646, 1647, 1650, 1651

LETTER	PART #	DESCRIPTION
A	369706	Thermocouple Assy. Left Hand
B	369735	Thermistor Assy. Left Hand
C	369702	Blower Motor, Left Hand
D	369574	Spark Generator
E	369937	Burner Venturi & End Cap 1646 Only
	369773	Burner Venturi & End Cap 1647 Only
F	369757	Main Burner Orifice - 1646
	369758	Main Burner Orifice - 1647
	370052	Main Burner Orifice - 1650
	370051	Main Burner Orifice - 1651
G	369689	Pressure Tap Fitting
H	369398	Solenoid Valve
J	369556	By-Pass Orifice - Natural
	369557	By-Pass Orifice - L.P
	370053	By-Pass Orifice 1650-1651
K	369570	Connector, 3-Pole
L	369571	Connector, 4-Pole
M	369580	Gas Valve, Multi-Block
N	369590	Igniter Sensor Assy.
O	369589	Burner Blower Motor
P	369013	Fuse, 3 Amp
Q	357107	Fuseholder
R	369368	Thermostat, Hi-Limit
S	369771	Switch, Burner Reset
T	369573	Ignition Control
U	369575	Air Pressure Switch
V	369786	Chain
W	369579	Alarm, Burner
X	369192	Capacitor
Y	369189	Terminal Block, 4-Pole
Z	369507	Thermostat, Cooling Fan
AA	369738	Sail Switch Assy.

BLOW UP / CONTROL BOX LEFT – 1646,1647,1650,1651

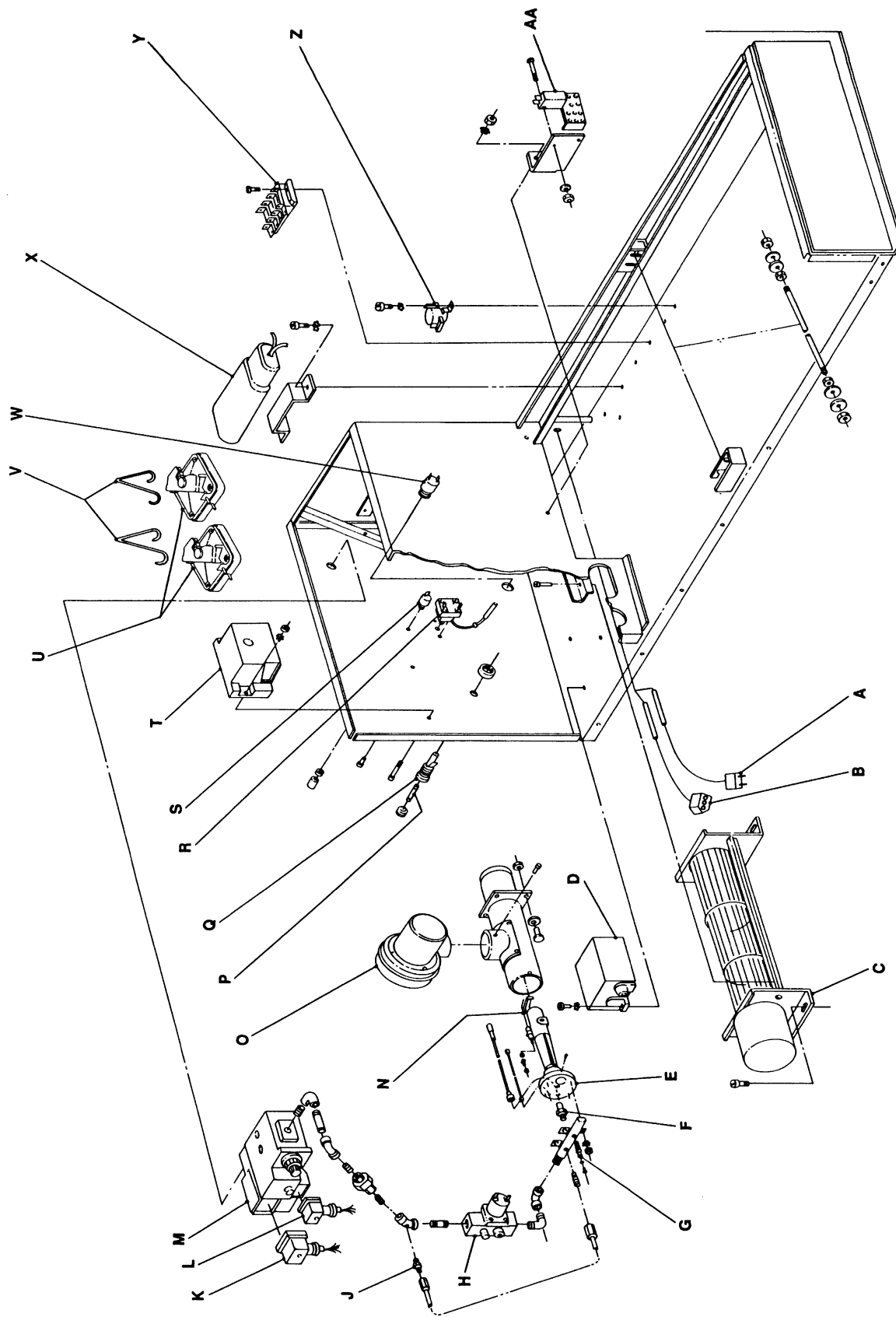

PARTS / BACK - 1600 SERIES

LETTER	PART #	DESCRIPTION
A	369724	Fan, Clockwise Rotation
B	369776	Fan Shroud
C	369777	Stand-Off
D	369778	Rear Wall Assy.
E	369761	Motor Mount (S/N 15184 & Above)
F	369726	Motor, Main Fan 120V 60 Hz
	369759	Motor, Main Fan 220/240V 50 Hz
G	369033	Motor Clamp
H	1608	Top Cap (Gas S/N 16837 & Below)
J	369750	Duct Assy. (Rear Cover) S/N 16837 & Below
K	369732	Motor Cover Flue (S/N 16837 & Below)
L	369725	Fan, Counter Clockwise Rotation
M	369779	Baffle, Right Hand (Gas Ovens)
	369787	Baffle, Right Hand (Electric Ovens)
N	369547	Wire Form, Thermostat
O	369780	Baffle, Left Hand (Gas Ovens)
	369788	Baffle, Left Hand (Electric Ovens)
P	369760	Motor Mount (S/N 15183 & Below)
Q	369791	Duct Assy. (Rear Cover) S/N 16838 & Above
R	1607	Top Cap - Gas (S/N16838 & Above)
	1627	Top Cap - Electric (S/N 16838 & Above)

BLOW UP / BACK – 1600 SERIES

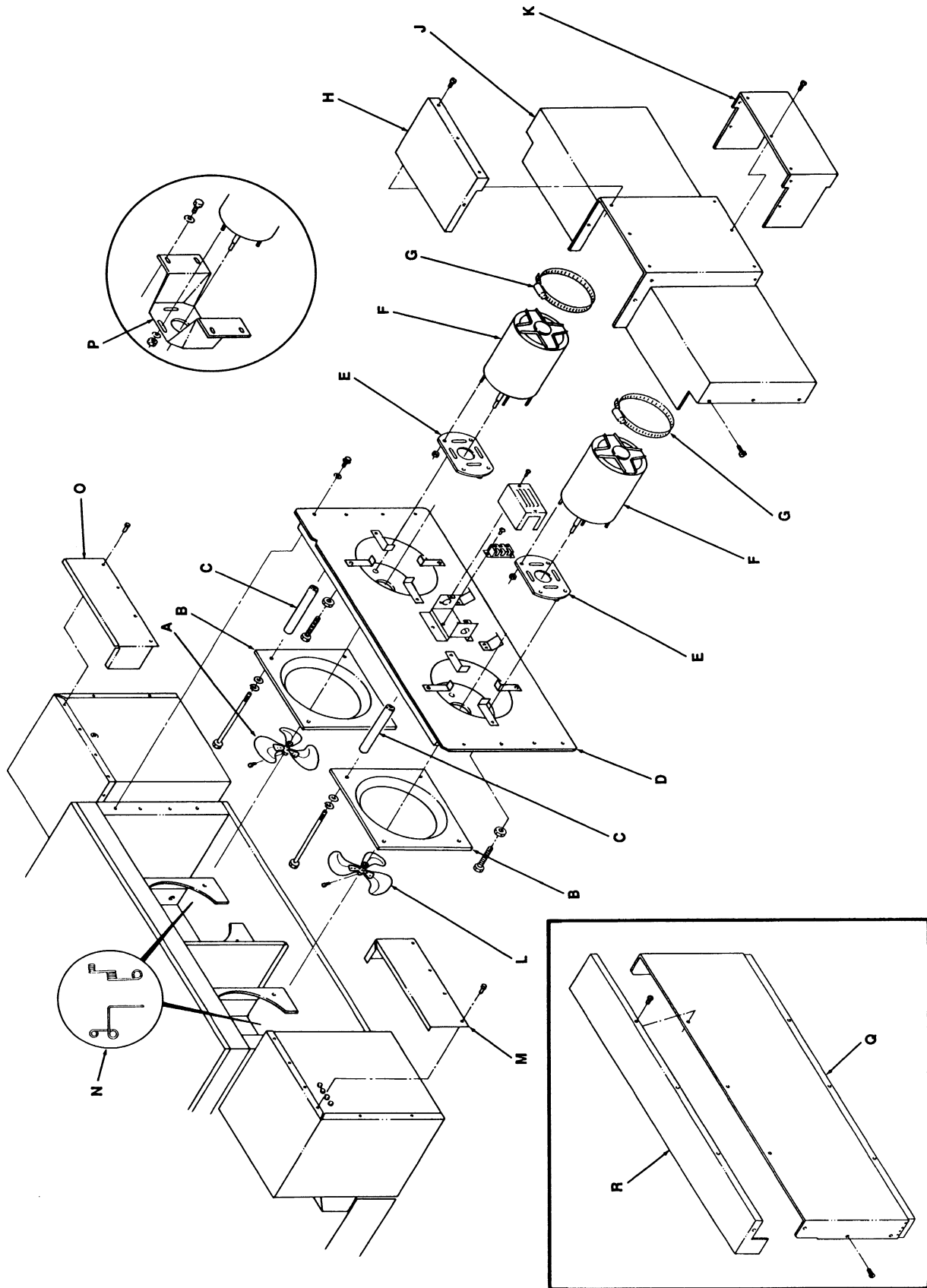

PARTS / CONVEYOR - 1600 SERIES

LETTER	PART #	DESCRIPTION
A	369117	Complete Conveyor Assy.
	369002	Tension Knob, Conveyor
B	369314	Roller - Notched
C	370089	Jam Nut
D	369312	Shaft, Idler
E	369160	Conveyor Pan Stop
F	369641	Idle Bearing Bracket
G	369220	Idle Bearing
H	369005	Conveyor Belt Connecting Links
I	369237	Drive Shaft
J	369066	Drive Sprocket
K	369219	Rod End, Female
L	369644	Screw 1/2-20 x 3/4
M	369206	Crumb Pan
N	369163	Conveyor Belt
	369362	Conveyor Belting (1 Foot Section)
O	369835	Conveyor Frame Assy.
(Not Shown)	369731	Drive Chain
(Not Shown)	369017	Master Link for Drive Chain

BLOW UP / CONVEYOR – 1600 SERIES

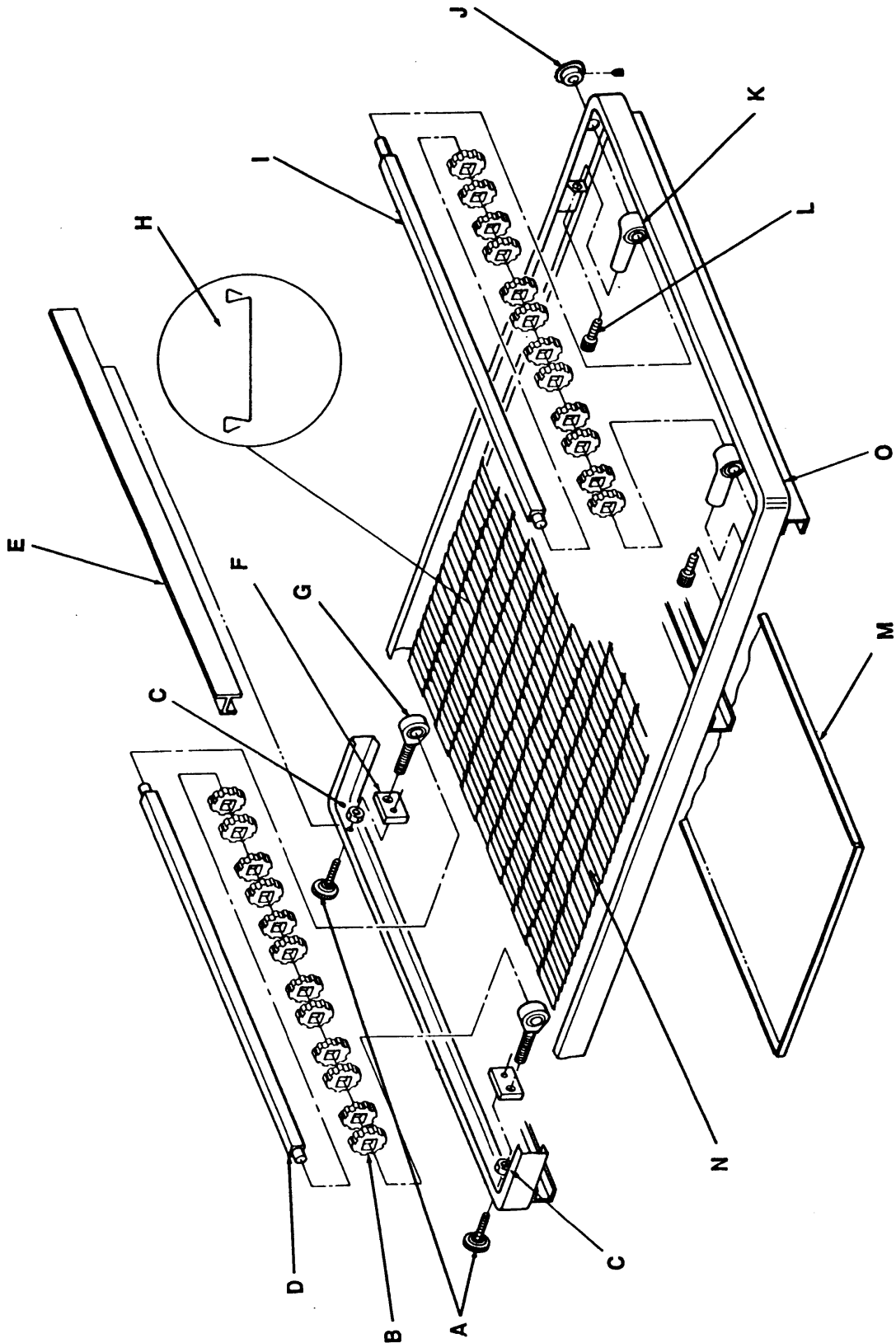

This page intentionally left blank.

This page intentionally left blank.

