

SERVICE MANUAL

(DOMESTIC)

IMPINGER CONVEYOR OVENS

MODEL 1100 SERIES



Lincoln Foodservice Products, LLC
1111 North Hadley Road
Fort Wayne, Indiana 46804
United States of America

Phone: (260) 459-8200

U.S. Fax: (888) 790-8193 • Int'l Fax: (260) 436-0735

Technical Service Hot Line
(800) 678-9511

www.lincolnfp.com



TABLE OF CONTENTS

SEQUENCE OF OPERATIONS 1100 thru 1103	3
SEQUENCE OF OPERATIONS 1116 - 1117	4
SEQUENCE OF OPERATIONS 1130 - 1133 & 1160 - 1163.....	6
SCHEMATIC 1100 – 1101	8
SCHEMATIC 1102-1103	9
SCHEMATIC 1116 – 1117 S/N 2011383 & BELOW	10
SCHEMATIC 1116 – 1117 S/N 2011384 & ABOVE	11
SCHEMATIC 1130 – 1131 S/N 2011383 & BELOW & 1160 – 1161 S/N 2011978 & BELOW.....	12
SCHEMATIC 1130 – 1131 S/N 2011384 & ABOVE	13
SCHEMATIC 1160 – 1161 S/N 2011978 & ABOVE	14
SCHEMATIC 1132 – 1133 S/N 2011383 & BELOW & 1162 – 1163 S/N 2011979 & BELOW.....	15
SCHEMATIC 1132 – 1133 S/N 2011384 & ABOVE	16
SCHEMATIC 1162 – 1163 S/N 2011978 & ABOVE	17
TROUBLESHOOTING GUIDE 1116 - 1117.....	18
TROUBLESHOOTING GUIDE 1100 THRU 1103.....	22
TROUBLESHOOTING GUIDE 1130 THRU 1133 / 1160 THRU 1163.....	24
REMOVAL, INSTALLATION, AND ADJUSTMENT	31
PARTS / GENERAL –1100 SERIES	50
BLOW UP / GENERAL – 1100 SERIES.....	51
PARTS / CONTROL COMPARTMENT FRONT 1100 - 1106, 1130 - 1136, 1150,1151,1160 – 1163	52
BLOW UP / CONTROL COMPARTMENT FRONT 1100 – 1106,1130 – 1136, 1150,1151,1160 – 1163	53
PARTS / CONTROL COMPARTMENT FRONT 1116,1117	54
BLOW UP / CONTROL COMPARTMENT FRONT 1116, 1117.....	55
PARTS / CONTROL COMPARTMENT REAR 1100 – 1106, 1130 – 1136, 1150,1151, S/N 2011373 & BELOW, 1160 – 1163 S/N 2011978 & BELOW	56
BLOW UP / CONTROL COMPARTMENT REAR 1100 – 1106, 1130 – 1136, 1150,1151, S/N 2011373 & BELOW, 1160 – 1163 S/N 2011978 & BELOW	57
PARTS / CONTROL COMPARTMENT REAR 1130 - 1136, 1150, 1151, S/N2011383 AND ABOVE, 1160 – 1163 S/N 3011978 AND ABOVE.....	58
BLOW UP / CONTROL COMPARTMENT REAR 1130 - 1136, 1150, 1151, S/N2011383 AND ABOVE, 1160 – 1163 S/N 3011978 AND ABOVE.....	59
PARTS / CONTROL COMPARTMENT REAR 1116, 1117, S/N 2000200 TO 2011383	60
BLOW UP / CONTROL COMPARTMENT REAR 1116, 1117, S/N 2000200 TO 2011383.....	61
PARTS / CONTROL COMPARTMENT REAR 1116, 1117 S/N 2011383 & ABOVE	62
BLOW UP / CONTROL COMPARTMENT REAR 1116, 1117 S/N 2011383 & ABOVE.....	63
PARTS / OVEN BACK ASSEMBLY 1100 SERIES.....	64
BLOW UP / OVEN BACK ASSEMBLY 1100 SERIES	65
PARTS / GEARMOTOR ASSEMBLY 1100 SERIES	66
BLOW UP / GEARMOTOR ASSEMBLY 1100 SERIES.....	67
PARTS / CONVEYOR & DOOR 1100 SERIES	68
BLOW UP / CONVEYOR & DOOR 1100 SERIES.....	69

SEQUENCE OF OPERATIONS 1100 THRU 1103

MODEL 1100 / ELECTRIC / 120/208 VAC / 60 HZ / 1 PHASE
 MODEL 1101 / ELECTRIC / 120/240 VAC / 60 HZ / 1 PHASE
 MODEL 1102 / ELECTRIC / 120/208 VAC / 60 HZ / 3 PHASE
 MODEL 1103 / ELECTRIC / 120/240 VAC / 60 HZ / 3 PHASE

POWER SUPPLY	<p>Electrical Power to be supplied to the oven by a four conductor cord set on single phase and a five conductor cord set on three phase.</p> <p>Voltage from the black conductor to the white conductor is 120 VAC.</p> <p>Black conductor is Hot.</p> <p>Red conductor is Hot.</p> <p>Orange conductor is Hot. (Used on 3Ø only)</p> <p>White conductor is dedicated neutral.</p> <p>Green conductor is ground.</p>
MAIN FAN CIRCUIT	<p>Power is permanently supplied to the normally open contacts of the main fan relay, through a 10A fuse, to the normally open cool down thermostat, and to the normally open main fan switch. Closing the main fan switch energizes the coil of the main fan relay. Its normally open contacts now close energizing the main fan motor. Closing the main fan switch energizes the cooling fan, the time/temp transformer, the heat and conveyor switches.</p>
HEATER CIRCUIT	<p>Closing the Heater Switch provides power through the normally open Air Pressure Switch, through the 3 Amp Fuse, to the Temperature Control Board and to the Heater Lamp.</p>
TEMPERATURE CONTROL	<p>Closing the Heat Switch supplies 120 VAC to the Electronic Temperature Control. The 2.5K ohm Potentiometer is adjusted to achieve the desired temperature. The Thermocouple will provide varying millivolts to the Temperature Control. The temperature control board then supplies 120 VAC to the coil of the Contactor at intermittent intervals to maintain the desired temperature.</p> <p>NOTE: Units with Serial Number prior to 2000782 were equipped with a Fenwall Temperature Control and used a Temperature Control Potentiometer rated at 5K ohms.</p>
CONVEYOR DRIVE	<p>Closing the Conveyor Switch supplies 120 VAC to the DC Motor Control Board at terminals L1 and L2. A.C.volts are converted to DC volts and are supplied to the Conveyor Motor at terminals A+ and A-. Adjustment of the Speed Control Potentiometer (5,000 ohm, 10 turn) will change resistance at terminals P1, P2, and P3 varying the DC voltage to the Conveyor Motor. The speed of the conveyor motor will increase or decrease as the DC voltage from the board increases or decreases respectively. As the motor turns, it drives both the reducer gear box and the tach. generator. The tach. generator is a DC voltage generator which supplies a voltage to the DC Motor Control Board which is used as a reference for maintaining a constant conveyor speed.</p>
TIME/TEMP DISPLAY	<p>The secondary output of the Transformer, is supplied to terminals 1, 2, and 3 of the Time/Temp. Display. The secondary output of the Transformer is nominally 12.5 to 15 VAC with a center tap. The voltage from the center tap to each leg is 1/2 the secondary voltage. The speed side of the Time/Temp. Display uses a slotted disc (cemented to tach. coupling) to break the infra-red light beam of the optical encoder (mounted on gear motor), producing electrical pulses that are transmitted to the display. The display converts these pulses into a read-out of minutes and seconds. The temperature portion of the Time/Temp Display thermistor outputs a resistance proportional to the oven temperature. This resistance is then converted by the display into a temperature reading.</p>
AUTOMATIC COOL DOWN	<p>When the oven reaches operating temperature the normally open Oven Cool Down Thermostat closes. After oven is switched OFF, the Thermostat bypasses the Fan Switch, keeping the Cooling Fan and Main Fan operating until the oven cools down to approximately 200°F (93.3°C).</p>

SEQUENCE OF OPERATIONS 1116 - 1117

MODEL 1116 / NATURAL GAS / 120 VAC / 60 HZ / 1 PHASE
 MODEL 1117 / L.P GAS / 120 VAC / 60 HZ / 1 PHASE

POWER SUPPLY	Electrical power is supplied to the oven by a three conductor cord set. Voltage from the black conductor to the white conductor is 120 VAC. The white conductor is neutral. The green conductor is ground.
CONTROL BOX AUTO	When the temperature in the control box reaches 120°F ± COOL DOWN 3°(48.9°C ± 1.7°C), the Cooling Fan Thermostat will switch power to the Control Box Cooling Fans. The thermostat will interrupt power to the fans when the control box temperature falls to 100°F ± 3° (37.8°C ± 1.7°C).
MAIN FAN CIRCUIT	Power is permanently supplied to the normally open contacts of the oven fan relay, the normally open cooling fan thermostat, terminal #1 of the time delay relay and the normally open main fan switch. Closing the main fan switch enables the 20 minutes time delay relay. The time delay relay supplies 120 VAC to the coil of the main fan relay. These normally open contacts now close energizing the main fan motor and the cooling fans. Closing the fan switch also energizes the time/temp display, the heat and conveyor switches.
BURNER CIRCUIT	Closing the Burner Switch supplies 120 VAC through the 10 Amp Fuse, through the Main Fan Motor Centrifugal Switch, and oven cavity High Limit Thermostat to terminal L1 of the Ignition Control. The Centrifugal Switch of the Main Fan Motor closes when the fan motor reaches 1600 RPM. The High Limit Thermostat opens at 662°F(350°C) and may be manually reset after the sensing bulb temperature drops 18°F(10°C). Power (120 VAC) is also supplied to the Burner Blower Motor. As this motor reaches approximately 1600 RPM, its Internal Centrifugal Switch closes, supplying 120 VAC through the normally closed Control Box High Limit Thermostat, to the primary of the 24 VAC Transformer and the Temperature Control. The Control Box High Limit Thermostat is manually re-settable and opens when the control box reaches 170°F ± 5°(76°C ± 3°C). (Discontinued at S/N 2011383)
IGNITION CONTROL	The Ignition Control operates on both 24 VAC and 120 VAC. When the control is energized by 24 VAC from the Transformer, 120 VAC is switched by the Ignition Control to the Hot Surface Ignitor for 45 seconds for Hot Surface Ignitor warm up. The Ignitor glows red, 24 VAC is switched to the gas valve which opens, and ignition should now occur. If ignition does not occur in 6 seconds, the control will lock out. To recycle after lockout, turn off the burner switch for 45 seconds and then turn the switch back on.
TEMPERATURE CONTROL	When the Centrifugal Switch of the Burner Blower Motor closes, power is applied to the Temperature Control. The 2.5K ohm Temperature Pot is adjusted to desired temperature. The Thermocouple will provide varying millivolts to the Temperature Controller. The Temperature Controller supplies 120 VAC to the Solenoid Valve at intermittent intervals to maintain desired temperature.
CONVEYOR DRIVE	Closing the Fan Switch and the Conveyor Switch, supplies 120 VAC through 3 Amp Fuse to L1 and L2 of the Motor Control Board. AC volts are converted to DC by the Control Board and are supplied to the Motor from Board terminals A+ and A-. Adjustment of the Speed Control Pot (5,000 ohm 10 turn pot) will change resistance at terminals P1, P2, and P3 varying S/N 2011383 and above the DC voltage to the motor. The speed of the Conveyor Motor Refer to page 26 will increase or decrease as the DC voltage from the board increases or decreases respectively. As the motor turns, it drives both the Reducer Gear Box and the Tach. Generator. The Tach. Generator is a DC voltage Generator that supplies a voltage to the DC Motor Control Board and is used as a reference for maintaining a constant conveyor speed.
TIME/TEMP DISPLAY	The secondary output of the Transformer, is supplied to terminals 1, 2, and 3 of the Time/Temp. Display. The secondary output of Transformer is nominally 12.5 to 15 VAC with a center tap. The voltage from center tap to each leg is 1/2 the secondary voltage.

S/N 2011383 and above	<p>The speed side of the Time/Temp. Display uses a slotted disc Refer to page 27 (cemented to tach. coupling) to break the infra-red light beam of the optical encoder (mounted on gear motor), producing electrical pulses that are transmitted to the display. The display converts these pulses into a read-out of minutes and seconds.</p> <p>The temperature portion of the Time/Temp Display uses a Thermistor Probe to sense oven temperature. The thermistor This resistance is then converted by the display into a temperature reading.</p>
AUTOMATIC COOL DOWN	<p>When this oven is started, the time delay relay timing circuit is enabled, permitting the oven fans to run for approximately 20 minutes after the oven is shutoff, to cool the oven. The Time Delay Relay will keep the coil of the Main Fan Relay closed, maintaining operation of main fan and Cooling Fan Motors.</p>

SEQUENCE OF OPERATIONS 1130 - 1133 & 1160 - 1163

MODEL 1130 / ELECTRIC / 120/208 VAC / 1 PHASE
 MODEL 1131 / ELECTRIC / 120/240 VAC / 1 PHASE
 MODEL 1132 / ELECTRIC / 120/208 VAC / 3 PHASE
 MODEL 1133 / ELECTRIC / 120/240 VAC / 3 PHASE
 MODEL 1160 / ELECTRIC / 120/208 VAC / 1 PHASE
 MODEL 1161 / ELECTRIC / 120/240 VAC / 1 PHASE
 MODEL 1162 / ELECTRIC / 120/208 VAC / 3 PHASE
 MODEL 1163 / ELECTRIC / 120/240 VAC / 3 PHASE

POWER SUPPLY	<p>Electrical Power to be supplied to the oven by a four conductor service on single phase and a five conductor service on three phase.</p> <p>Voltage from the black conductor to the white conductor is 120 VAC. Black conductor is Hot. Red conductor is Hot. Orange conductor is Hot. (Used on 3Ø only) White conductor is dedicated neutral. Green conductor is ground.</p> <p>NOTE: A 20 Amp Receptacle, NEMA STYLE L6-20, is provided on Models 1160, 1161, 1162, and 1163 for accessory plug in. Rated at 208 or 240 VAC.</p>
CONTROL BOX AUTO COOL DOWN	<p>When the temperature in the control box reaches 120°F ±3°F(48.9°F ± 1.7°C), the Cooling Fan Thermostat will switch power to the Cooling Fans. The thermostat will interrupt power to the fans when the temperature falls to 100°F ± 3°F(37°C ± 1.7°C).</p>
MAIN FAN CIRCUIT	<p>Electrical power is permanently supplied through a 10 amp fuse to terminal 1 of the 20 Minute Timer, through the normally closed Hi Limit Thermostat to the fan switch. Closing fan switch energizes the coil of the oven start relay, its contacts close enabling the 20 minute time delay module. The 20 minute time delay module supplies 120 VAC to the oven fan relay, these normally open contacts now close supplying 208/240 VAC to the main fan motor. The cooling fans are also energized. Closing the fan switch also supplies 120 VAC to the Heater Switch/Conveyor Switch, and the display Transformer.</p>
HEATER CIRCUIT	<p>Closing the Heat Switch supplies 120 V AC through the normally open Air Pressure Switch (closed by air pressure from the Main Fan), the 3 Amp Fuse, to L1 terminal of the Temperature Control Board, and the Heat Indicator Light.</p>
TEMPERATURE CONTROL	<p>Closing the Heat Switch supplies 120 VAC to the Electronic Temperature Control. The 2.5K ohm Potentiometer is adjusted to achieve the desired temperature. The Thermocouple will provide varying millivolts to the Temperature Control. The temperature control board then supplies 120 VAC to the coil of the Contactor at intermittent intervals to maintain the desired temperature.</p>
CONVEYOR DRIVE (S/N 2011383 and above Models 1130 through 1133). S/N 2011978 and above Models 1160 through 1163 Refer to Page 26)	<p>Closing the Conveyor Switch supplies 120 VAC to the DC Motor Control Board at terminals L1 and L2. AC volts are converted to DC volts and are supplied to the Conveyor Motor at terminals A+ and A-. Adjustment of the Speed Control Potentiometer (5,000 ohm, 10 turn) will change resistance at terminals P1, P2, and P3 (varying the DC voltage to the Conveyor Motor. The through speed of the conveyor motor will increase or decrease as the DC voltage from the board increases or decreases respectively. As the motor turns, it drives both the reducer gear box and the tach. generator. The tach. Generator is a DC voltage generator which supplies a voltage to the DC Motor Control Board and is used as a reference for maintaining a constant conveyor speed.</p>
TIME/TEMP DISPLAY	<p>The secondary output of the Transformer, is supplied to terminals 1, 2, and 3 of the Time/Temp. Display. The secondary output of Transformer is nominally 12.5 to 15 VAC with a center tap. The voltage from center tap to each leg is 1/2 the secondary voltage. The speed side of the Time/Temp. Display uses a slotted disc (S/N 2011383 and above on (cemented to tach. coupling) to break the infra-red light beam Models 1130 through 1133 of the optical encoder (mounted on gear motor), producing electrical pulses that are</p>

	transmitted to the display. The display converts these pulses into a read-out of minutes and seconds. The temperature portion of the Time/Temp Display uses a thermistor probe to sense oven temperature. The thermistor outputs a resistance proportional to the oven temperature. This resistance is then converted by the display into a temperature reading.
AUTOMATIC COOL DOWN	When this oven is started, the time delay relay timing circuit is enabled, permitting the oven fans to run for approximately 20 minutes after the oven is shut off, to cool the oven. The Time Delay Relay will keep the coil of Relay closed, maintaining operation of main fan and Cooling Fan Motors.

SCHEMATIC 1100 - 1101

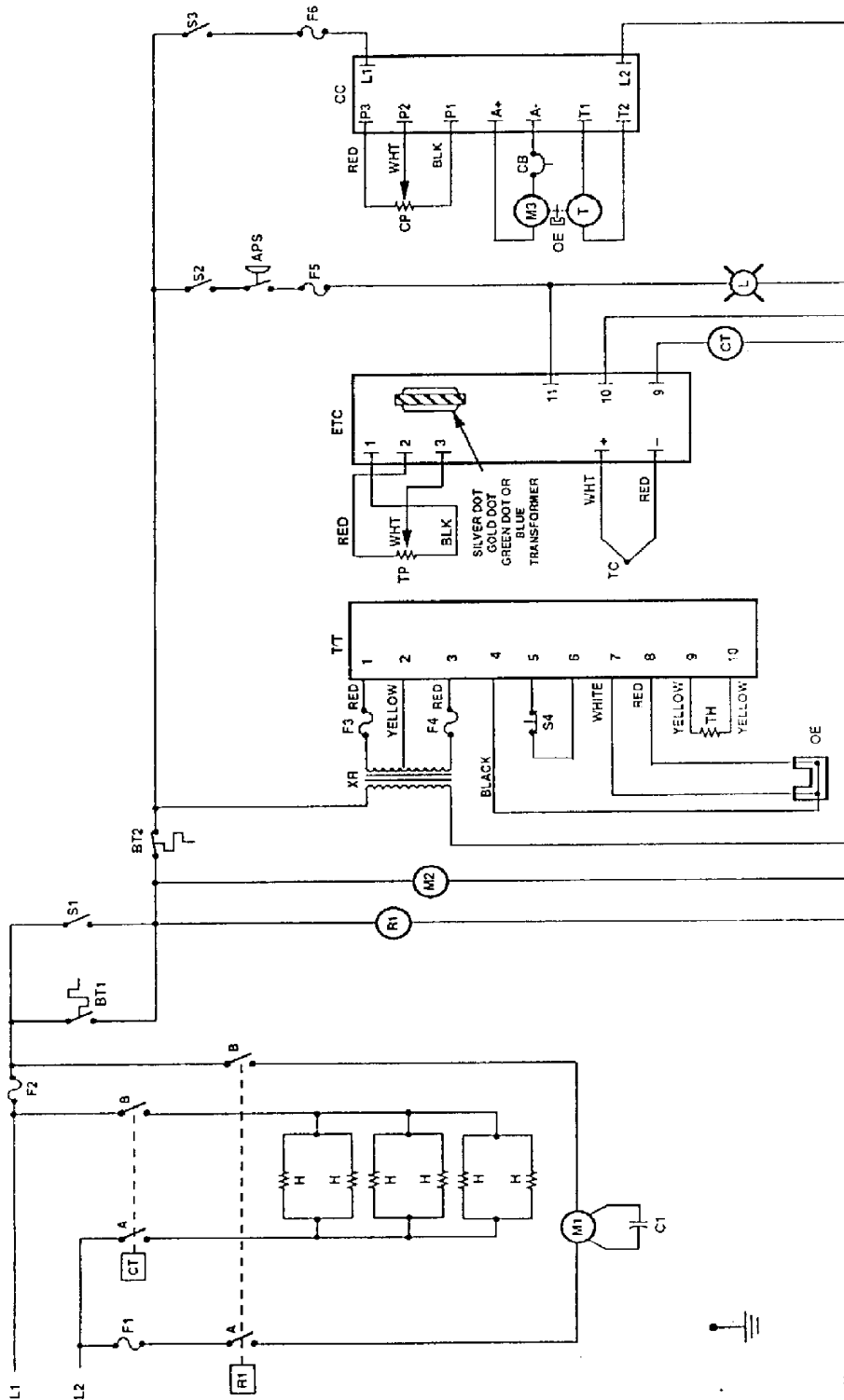

- AP5 - SWITCH AIR PRESSURE
- BT1 - SWITCH COOL DOWN
- BT2 - THERMOSTAT OVER CAVITY HIGH LIMIT
- C1 - CAPACITOR, 7.5 MFD 375V MAIN FAN MOTOR
- CB - CIRCUIT BREAKER, 5.2 AMP
- CC - CONTROL BOARD, D.C. MOTOR
- CP - MOTOR BOARD, 1/2 AMP, 10 TURN
- CT - POTENTIOMETER, 250 OHMS, 10 TURN
- H - HEATING ELEMENTS
- M - MOTOR COOLING FAN
- M1 - MOTOR COOLING FAN
- M2 - MOTOR COOLING FAN
- M3 - GEAR MOTOR
- OE - OPTICAL ENCODER
- R1 - RELAY MAIN FAN SPST
- R2 - SWITCH MAIN FAN SPST
- S1 - SWITCH HEATING SPST
- S2 - SWITCH CONVEYOR SPST
- S3 - SWITCH CONVEYOR SPST
- S4 - SWITCH DISP. AT SET
- T - TACHOMETER
- TH - THERMOSTAT
- TP - THERMISTOR PROBE
- TC - THERMISTOR
- TP - POTENTIOMETER 0.2-3K OHMS
- T1 - DISPLAY, TIME TEMP.
- TR - TRANSFORMER, 12.6 VAC
- XR - FUSE, 10 AMP, MAIN FAN MOTOR
- F1 - FUSE, 10 AMP, MAIN FAN MOTOR CONTROLS
- F2 - FUSE, 1 AMP
- F3 - FUSE, 1 AMP
- F4 - FUSE, 1 AMP
- F5 - FUSE, 3 AMP, HEATER CIRCUIT
- F6 - FUSE, 3 AMP, CONVEYOR CIRCUIT
- M - MOTOR COOLING FAN
- M1 - MOTOR COOLING FAN
- M2 - MOTOR COOLING FAN
- M3 - GEAR MOTOR
- OE - OPTICAL ENCODER
- R1 - RELAY MAIN FAN SPST
- R2 - SWITCH MAIN FAN SPST
- S1 - SWITCH HEATING SPST
- S2 - SWITCH CONVEYOR SPST
- S3 - SWITCH CONVEYOR SPST
- S4 - SWITCH DISP. AT SET
- T - TACHOMETER
- TH - THERMOSTAT
- TP - POTENTIOMETER 0.2-3K OHMS
- TC - THERMISTOR
- TP - DISPLAY, TIME TEMP.
- TR - TRANSFORMER, 12.6 VAC

* Units with serial number 2000860 and below were originally equipped with a firewall temperature control which is deleted from parts inventory. Replace with firewall temperature control with part number 2000860. See SK1000 for control panel and adjustment instructions.

MODELS 1100 and 1101

SCHEMATIC 1102-1103

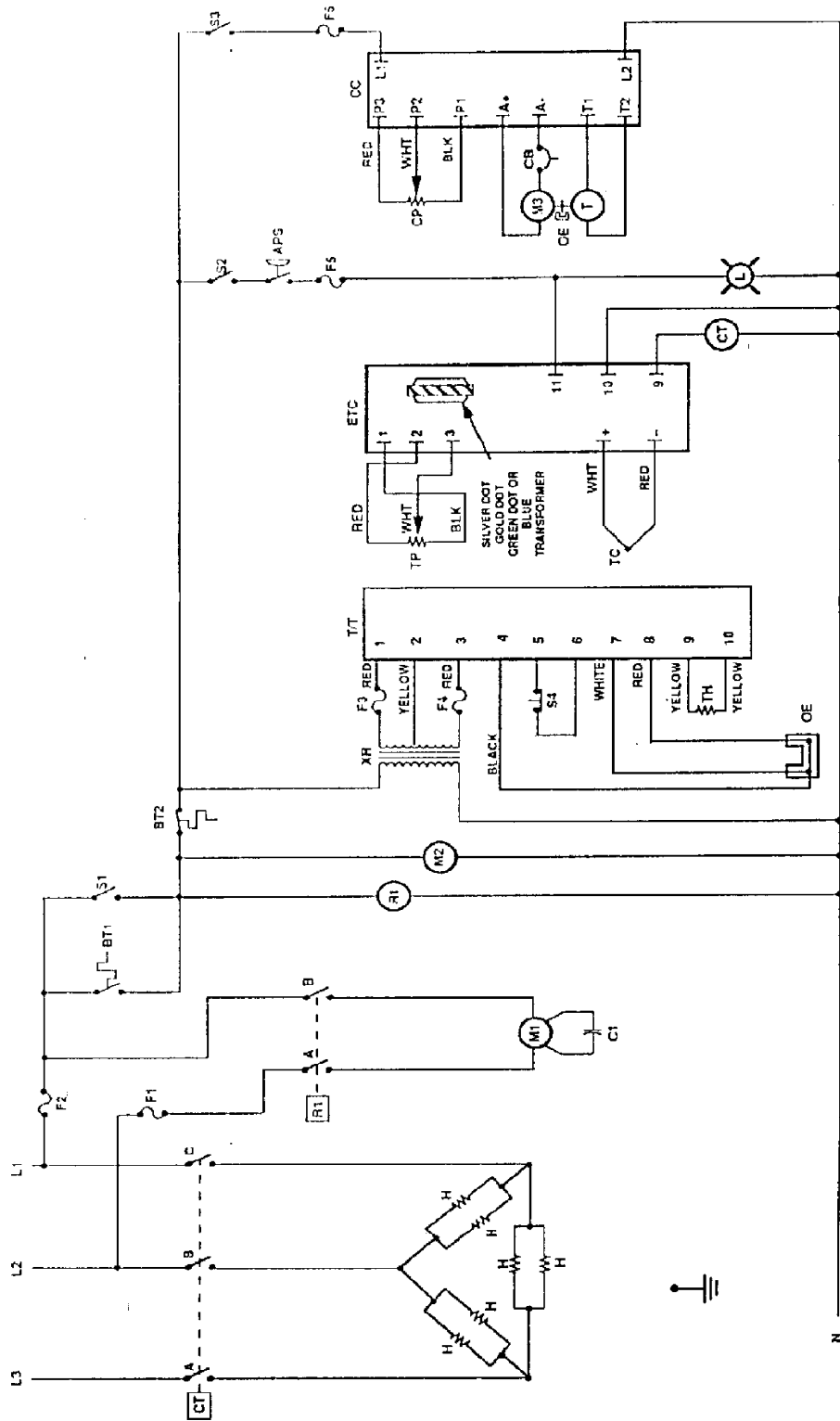

- APG - SWITCH, AIR PRESSURE
 BT1 - THERMOSTAT, OVER CAVITY HIGH LIMIT
 BT2 - THERMOSTAT, OVER CAVITY HIGH LIMIT
 C1 - CAPACITOR, 1.5 MFD 275V, MAIN FAN MOTOR
 CB - CONTACTOR, 30 AMP D.C. MOTOR
 CP - CONTACTOR, 30 AMP D.C. MOTOR
 CT - MERCURY CONTACTOR, 3 POLE
 H - HEATING ELEMENTS
 M1 - MOTOR, COOLING FAN
 M2 - MOTOR, MAIN FAN
 M3 - MOTOR, COOLING FAN
 M4 - MOTOR, COOLING FAN
 N - NEUTRAL
 OE - OPTICAL TROUSER
- F1 - FUSE, 10 AMP, MAIN FAN MOTOR
 F2 - FUSE, 1 AMP
 F3 - FUSE, 1 AMP
 F4 - FUSE, 1 AMP
 F5 - FUSE, 1 AMP
 L - LAMP, PILOT, HEATER CIRCUIT
 M1 - MOTOR, MAIN FAN
 M2 - MOTOR, COOLING FAN
 M3 - MOTOR, COOLING FAN
 M4 - MOTOR, COOLING FAN
 OE - OPTICAL TROUSER
- R1 - RELAY, MAIN FAN, 20V
 R2 - SWITCH, MAIN FAN, 20V
 S1 - SWITCH, HEATER, 20V
 S2 - SWITCH, COOLING, 20V
 S3 - SWITCH, PILOT, 20V
 T/T - THERMOSTAT
 TP - THERMISTOR PROBE
 TC - THERMOCOUPLE
 T1 - POTENTIOMETER, 0-5K OHMS
 T2 - POTENTIOMETER, 0-5K OHMS
 T3 - POTENTIOMETER, 0-5K OHMS
 T4 - POTENTIOMETER, 0-5K OHMS
 T5 - POTENTIOMETER, 0-5K OHMS
 T6 - POTENTIOMETER, 0-5K OHMS
 T7 - POTENTIOMETER, 0-5K OHMS
 T8 - POTENTIOMETER, 0-5K OHMS
 T9 - POTENTIOMETER, 0-5K OHMS
 T10 - POTENTIOMETER, 0-5K OHMS
 T11 - POTENTIOMETER, 0-5K OHMS
 T12 - POTENTIOMETER, 0-5K OHMS
 T13 - POTENTIOMETER, 0-5K OHMS
 T14 - POTENTIOMETER, 0-5K OHMS
 T15 - POTENTIOMETER, 0-5K OHMS
 T16 - POTENTIOMETER, 0-5K OHMS
 T17 - POTENTIOMETER, 0-5K OHMS
 T18 - POTENTIOMETER, 0-5K OHMS
 T19 - POTENTIOMETER, 0-5K OHMS
 T20 - POTENTIOMETER, 0-5K OHMS
 T21 - POTENTIOMETER, 0-5K OHMS
 T22 - POTENTIOMETER, 0-5K OHMS
 T23 - POTENTIOMETER, 0-5K OHMS
 T24 - POTENTIOMETER, 0-5K OHMS
 T25 - POTENTIOMETER, 0-5K OHMS
 T26 - POTENTIOMETER, 0-5K OHMS
 T27 - POTENTIOMETER, 0-5K OHMS
 T28 - POTENTIOMETER, 0-5K OHMS
 T29 - POTENTIOMETER, 0-5K OHMS
 T30 - POTENTIOMETER, 0-5K OHMS
 T31 - POTENTIOMETER, 0-5K OHMS
 T32 - POTENTIOMETER, 0-5K OHMS
 T33 - POTENTIOMETER, 0-5K OHMS
 T34 - POTENTIOMETER, 0-5K OHMS
 T35 - POTENTIOMETER, 0-5K OHMS
 T36 - POTENTIOMETER, 0-5K OHMS
 T37 - POTENTIOMETER, 0-5K OHMS
 T38 - POTENTIOMETER, 0-5K OHMS
 T39 - POTENTIOMETER, 0-5K OHMS
 T40 - POTENTIOMETER, 0-5K OHMS
 T41 - POTENTIOMETER, 0-5K OHMS
 T42 - POTENTIOMETER, 0-5K OHMS
 T43 - POTENTIOMETER, 0-5K OHMS
 T44 - POTENTIOMETER, 0-5K OHMS
 T45 - POTENTIOMETER, 0-5K OHMS
 T46 - POTENTIOMETER, 0-5K OHMS
 T47 - POTENTIOMETER, 0-5K OHMS
 T48 - POTENTIOMETER, 0-5K OHMS
 T49 - POTENTIOMETER, 0-5K OHMS
 T50 - POTENTIOMETER, 0-5K OHMS
 T51 - POTENTIOMETER, 0-5K OHMS
 T52 - POTENTIOMETER, 0-5K OHMS
 T53 - POTENTIOMETER, 0-5K OHMS
 T54 - POTENTIOMETER, 0-5K OHMS
 T55 - POTENTIOMETER, 0-5K OHMS
 T56 - POTENTIOMETER, 0-5K OHMS
 T57 - POTENTIOMETER, 0-5K OHMS
 T58 - POTENTIOMETER, 0-5K OHMS
 T59 - POTENTIOMETER, 0-5K OHMS
 T60 - POTENTIOMETER, 0-5K OHMS
 T61 - POTENTIOMETER, 0-5K OHMS
 T62 - POTENTIOMETER, 0-5K OHMS
 T63 - POTENTIOMETER, 0-5K OHMS
 T64 - POTENTIOMETER, 0-5K OHMS
 T65 - POTENTIOMETER, 0-5K OHMS
 T66 - POTENTIOMETER, 0-5K OHMS
 T67 - POTENTIOMETER, 0-5K OHMS
 T68 - POTENTIOMETER, 0-5K OHMS
 T69 - POTENTIOMETER, 0-5K OHMS
 T70 - POTENTIOMETER, 0-5K OHMS
 T71 - POTENTIOMETER, 0-5K OHMS
 T72 - POTENTIOMETER, 0-5K OHMS
 T73 - POTENTIOMETER, 0-5K OHMS
 T74 - POTENTIOMETER, 0-5K OHMS
 T75 - POTENTIOMETER, 0-5K OHMS
 T76 - POTENTIOMETER, 0-5K OHMS
 T77 - POTENTIOMETER, 0-5K OHMS
 T78 - POTENTIOMETER, 0-5K OHMS
 T79 - POTENTIOMETER, 0-5K OHMS
 T80 - POTENTIOMETER, 0-5K OHMS
 T81 - POTENTIOMETER, 0-5K OHMS
 T82 - POTENTIOMETER, 0-5K OHMS
 T83 - POTENTIOMETER, 0-5K OHMS
 T84 - POTENTIOMETER, 0-5K OHMS
 T85 - POTENTIOMETER, 0-5K OHMS
 T86 - POTENTIOMETER, 0-5K OHMS
 T87 - POTENTIOMETER, 0-5K OHMS
 T88 - POTENTIOMETER, 0-5K OHMS
 T89 - POTENTIOMETER, 0-5K OHMS
 T90 - POTENTIOMETER, 0-5K OHMS
 T91 - POTENTIOMETER, 0-5K OHMS
 T92 - POTENTIOMETER, 0-5K OHMS
 T93 - POTENTIOMETER, 0-5K OHMS
 T94 - POTENTIOMETER, 0-5K OHMS
 T95 - POTENTIOMETER, 0-5K OHMS
 T96 - POTENTIOMETER, 0-5K OHMS
 T97 - POTENTIOMETER, 0-5K OHMS
 T98 - POTENTIOMETER, 0-5K OHMS
 T99 - POTENTIOMETER, 0-5K OHMS
 T100 - POTENTIOMETER, 0-5K OHMS

MODELS 1102 and 1103

SCHEMATIC 1116 – 1117 S/N 2011383 & BELOW

MODELS 1116 and 1117

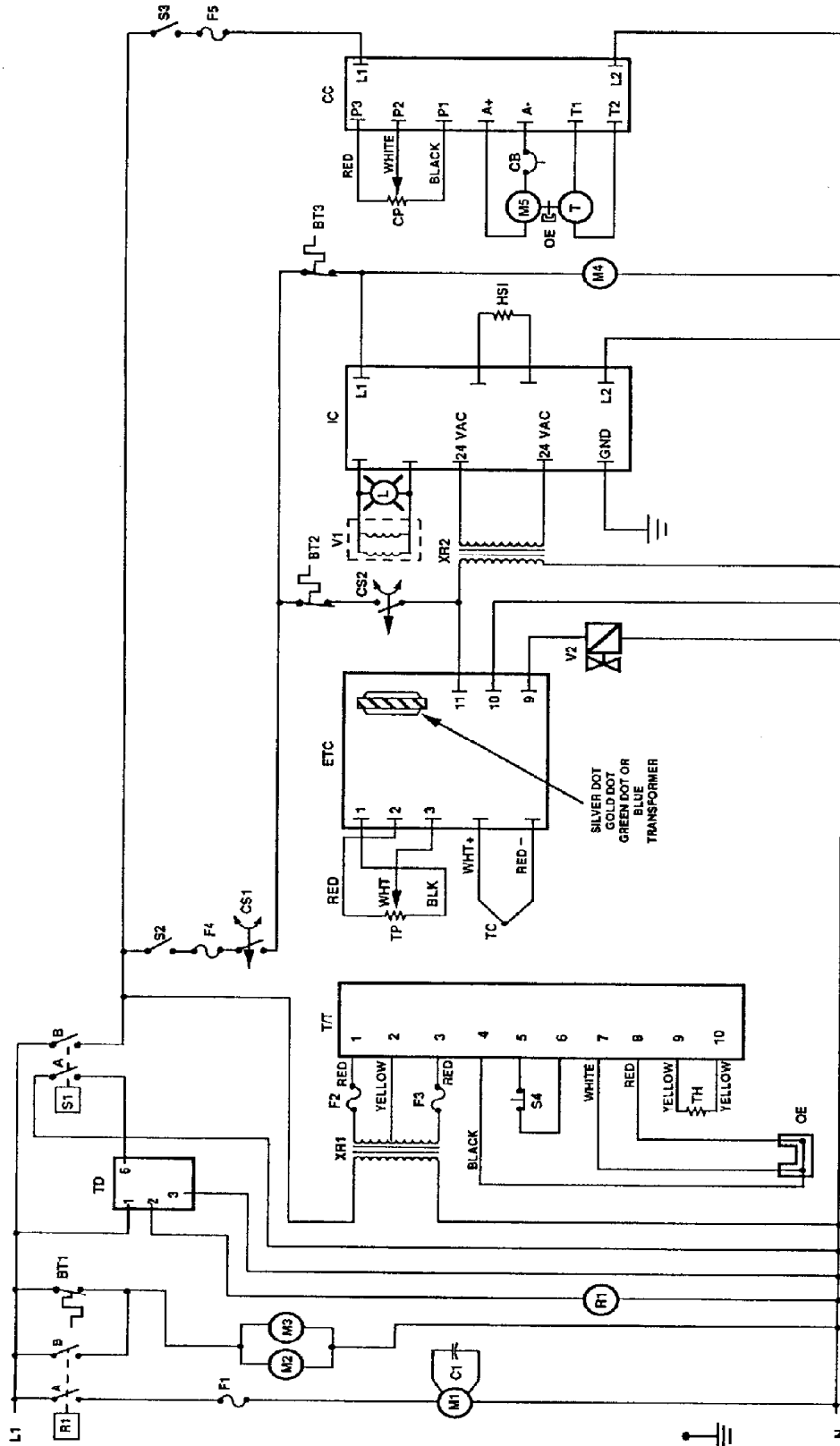

- TD - THERMOSTAT, CONTROL BOX HIGH LIMIT
- BT1 - THERMOSTAT, OVER CAVITY HIGH LIMIT
- C - CAPACITOR, 7.5 MFD 370 V, MAIN FAN MOTOR
- M1 - MOTOR, MAIN FAN, 0.2 AMP
- M2 - MOTOR, COOLING FAN, 0.2 AMP
- M3 - MOTOR, COOLING FAN, 0.2 AMP
- M4 - MOTOR, MAIN FAN BLOWER
- M5 - GEAR MOTOR
- OE - OPTICAL ENCODER
- R1 - RELAY, DPST, MAIN FAN
- S1 - SWITCH, MAIN FAN, SPST
- S2 - SWITCH, MAIN FAN, SPST
- S3 - SWITCH, MAIN FAN, SPST
- S4 - SWITCH, DISPLAY, SET
- T - TACHOMETER
- BT2 - TIME DEL. 30 MINUTE
- TC - THERMOCOUPLE
- TH - THERMISTOR PROBE
- TP - POTENTIOMETER, 0-2.5K OHMS
- TT - DISPLAY, TIME/TEMP
- V1 - SOLENOID, MAIN VALVE, WITH JOHNSON GAS VALVE, NATURAL GAS
- V2 - SOLENOID, MAIN VALVE, WITH JOHNSON GAS VALVE, NATURAL GAS
- XR1 - TRANSFORMER, 120 VAC WITH JOHNSON GAS VALVE (NATURAL GAS ONLY)
- XR2 - TRANSFORMER, 24 VAC
- XR3 - TRANSFORMER, 24 VAC

- BT1 - HOT SURFACE IGNITOR
- K - IGNITION CONTROL
- L - LAMP, FLUO, HEATING CIRCUIT
- M1 - MOTOR, MAIN FAN
- M2 - MOTOR, COOLING FAN
- M3 - MOTOR, COOLING FAN
- M4 - MOTOR, MAIN FAN BLOWER
- M5 - GEAR MOTOR
- OE - OPTICAL ENCODER
- R1 - RELAY, DPST, MAIN FAN
- S1 - SWITCH, MAIN FAN, SPST
- S2 - SWITCH, MAIN FAN, SPST
- S3 - SWITCH, MAIN FAN, SPST
- S4 - SWITCH, DISPLAY, SET
- T - TACHOMETER

- BT1 - THERMOSTAT, COOLING FAN
- BT2 - THERMOSTAT, CONTROL BOX HIGH LIMIT
- BT3 - THERMOSTAT, OVER CAVITY HIGH LIMIT
- C - CAPACITOR, 7.5 MFD 370 V, MAIN FAN MOTOR
- M1 - MOTOR, MAIN FAN, 0.2 AMP
- M2 - MOTOR, COOLING FAN, 0.2 AMP
- M3 - MOTOR, COOLING FAN, 0.2 AMP
- M4 - MOTOR, MAIN FAN BLOWER
- M5 - GEAR MOTOR
- OE - OPTICAL ENCODER
- R1 - RELAY, DPST, MAIN FAN
- S1 - SWITCH, MAIN FAN, SPST
- S2 - SWITCH, MAIN FAN, SPST
- S3 - SWITCH, MAIN FAN, SPST
- S4 - SWITCH, DISPLAY, SET
- T - TACHOMETER

SCHEMATIC 1130 – 1131 S/N 2011383 & BELOW & 1160 – 1161 S/N 2011978 & BELOW

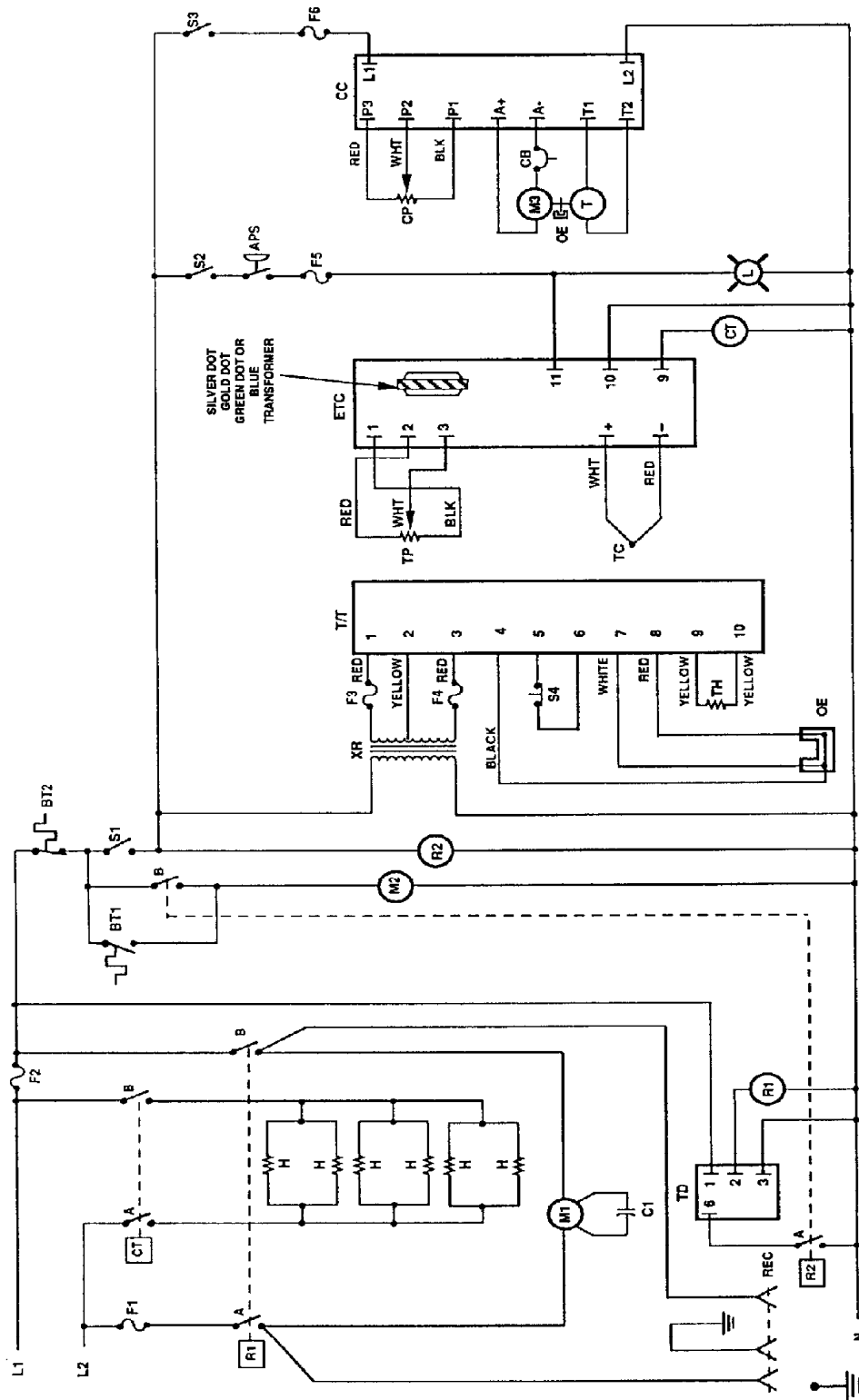

* Units with serial number 200880 and below were originally equipped with a Fanwell temperature control which is deleted from parts inventory. Replace with board 389728 plus a new potentiometer, part number 58300. See Section D for conversion and adjustment instructions.

NOTE: Used on 1189, 11E1 only.
REC - Receptacle, 20 AMP, 250 V NEMA LE-50

- R2 - RELAY, COOLING FAN
- S1 - SWITCH, MAIN FAN, SPST
- S2 - SWITCH, HEATING, SPST
- S3 - SWITCH, CONVEYOR, SPST
- S4 - SWITCH, DISPLAY, SPST
- T - THERMISTOR, 20 MINUTE
- TC - THERMISTOR PROBE
- TH - THERMISTOR
- TP - THERMISTOR PROBE, 0.2 BK OHMS
- T7 - DISPLAY, TIME/TEMP
- XR - TRANSFORMER, 12.5 VAC

- F1 - FUSE, 10 AMP, MAIN FAN MOTOR
- F2 - FUSE, 10 AMP, MAIN FAN MOTOR AND CONTROLS
- F3 - FUSE, 4 AMP
- F4 - FUSE, 4 AMP
- F5 - FUSE, 4 AMP
- F6 - FUSE, 3 AMP, TEMP CONTROL
- M1 - MOTOR, MAIN FAN, 1/2 HP
- M2 - MOTOR, COOLING FAN
- M3 - GEAR MOTOR
- OE - OPTICAL ENCODER
- R1 - RELAY, MAIN FAN, SPST

- APS - SWITCH, AIR PRESSURE
- BT1 - THERMISTAT, COOLING FAN
- BT2 - THERMISTAT, OVER CAVITY HIGH LIMIT
- C1 - CAPACITOR, 7.5 MFD 370V, MAIN FAN MOTOR
- CB - CIRCUIT BREAKER, 0.3 AMP
- CC - CONTROL BOARD, 0.3 AMP
- CP - POTENTIOMETER, 0.25 OHMS, 10 TURN
- H - HEATING ELEMENTS, 240 V
- TD - CONTROL BOARD, TEMPERATURE

MODELS 1130, 1131, 1160 and 1161

SCHEMATIC 1130 - 1131 S/N 2011384 & ABOVE

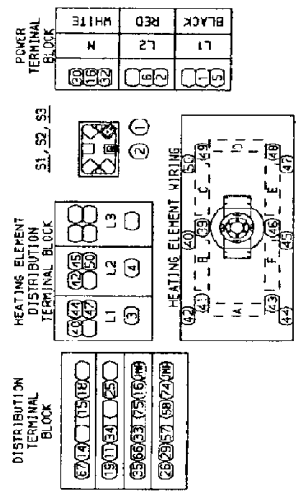
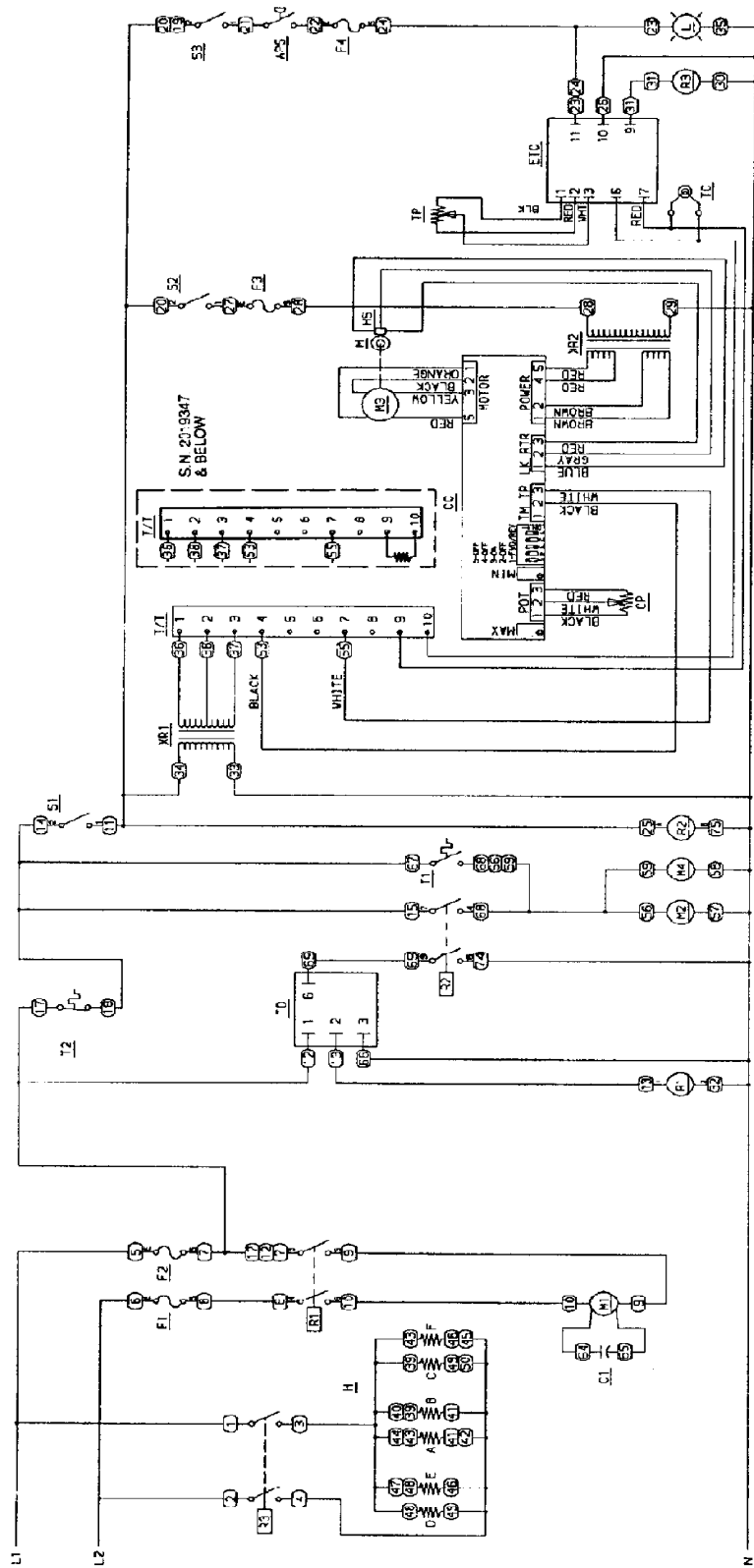

- APS - AIR PRESSURE SWITCH
- C1 - CAPACITOR, 2.5 MFD
- CP - CONVEYOR CONTROL
- ETC - ELECTRONIC TEMPERATURE CONTROL
- F1, F2 - FUSE, FAN MOTOR, CA
- F3 - FUSE, CONVEYOR CONTROL, 3A
- F4 - FUSE, TEMPERATURE CONTROL, 3A
- H - HALL EFFECT SENSOR, EACH (6 PCS)
- H - LAMP, HEATER INDICATOR
- M - MOTOR, OVEN FAN
- M1 - MOTOR, OVEN FAN
- M2, M4 - MOTOR, COOLING FAN
- M2 - MOTOR, CONVEYOR
- R1 - RELAY, OVEN FAN MOTOR
- R2 - RELAY, OVEN START & COOL DOWN
- RT - CONTACTOR, MERCURY
- S1 - SWITCH, OVEN FAN
- S2 - SWITCH, CONVEYOR
- S3 - SWITCH, OVEN HEAT
- T1 - THERMOSTAT, FLP - LIMIT
- T2 - THERMOCOUPLE, 20° F/10 MINUTES
- TP - TEMPERATURE POT ASSEMBLY
- T/P - TIME / TEMP TRANSFORMER
- TR1 - TRANSFORMER, TIME/TEMP
- TR2 - TRANSFORMER, CONVEYOR
- W - WIRE NUMBERS

MODELS 1130-1131

SCHEMATIC 1160 - 1161 S/N 2011978 & ABOVE

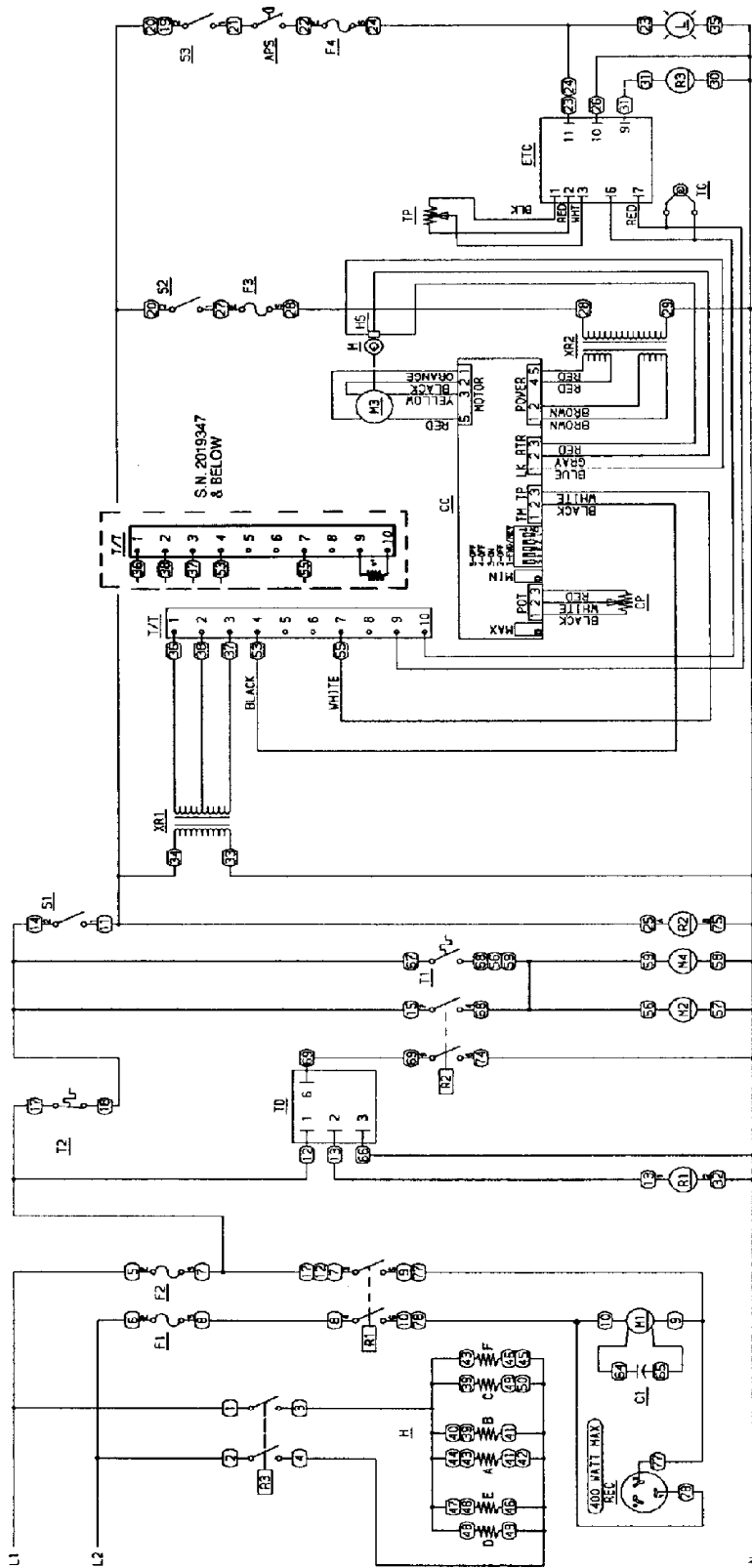

POWER TERMINAL BLOCK	HEATING ELEMENT TERMINAL BLOCK	DISTRIBUTION TERMINAL BLOCK
1 BLUE	1 L1	1 BLACK
2 BROWN	2 L2	2 BLACK
3 N	3 L3	3 BLACK
4 N	4 L4	4 BLACK
5 N	5 L5	5 BLACK
6 N	6 L6	6 BLACK
7 N	7 L7	7 BLACK
8 N	8 L8	8 BLACK
9 N	9 L9	9 BLACK
10 N	10 L10	10 BLACK

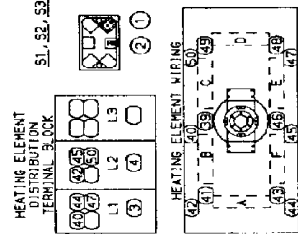

- R2 - RELAY, OVEN START & COOL DOWN
- REC - RECTIFIER, 16-20 20A, 250V
- S1 - SWITCH, OVEN FAN
- S2 - SWITCH, OVEN HEAT
- S3 - SWITCH, OVEN HEAT
- T1 - THERMOSTAT, CONTROL BOX COOLING
- TC - THERMOCOUPLE, HIGH LIMIT
- TD - THERMOCOUPLE, TYPE J
- TD - TIMER DELAY, 20 MINUTES
- TR - TRANSFORMER, POT ASSEMBLY
- TR1 - TRANSFORMER, TIME/TEMP
- TR2 - TRANSFORMER, CONVEYOR
- W1 - WIRE NUMBERS

- APS - AIR PRESSURE SWITCH
- C1 - CONVEYOR CONTROL
- CP - CONVEYOR POT ASSEMBLY
- ETC - ELECTRONIC TEMPERATURE CONTROL
- F1, F2 - FUSE, FAN MOTOR, 10A
- F3 - FUSE, CONVEYOR CONTROL, 3A
- F4 - FUSE, TEMPERATURE CONTROL, 3A
- H - HEAT/TEMP ELEMENTS 1000W (6 PCS)
- L - LAMP HEATER INDICATOR
- M1 - MOTOR, OVEN FAN
- M2, M4 - MOTOR, COOLING FAN
- M3 - MOTOR, CONVEYOR
- RT - RELAY, OVEN FAN MOTOR

MODELS 1160 and 1161

SCHEMATIC 1132 – 1133 S/N 2011383 & BELOW & 1162 – 1163 S/N 2011979 & BELOW

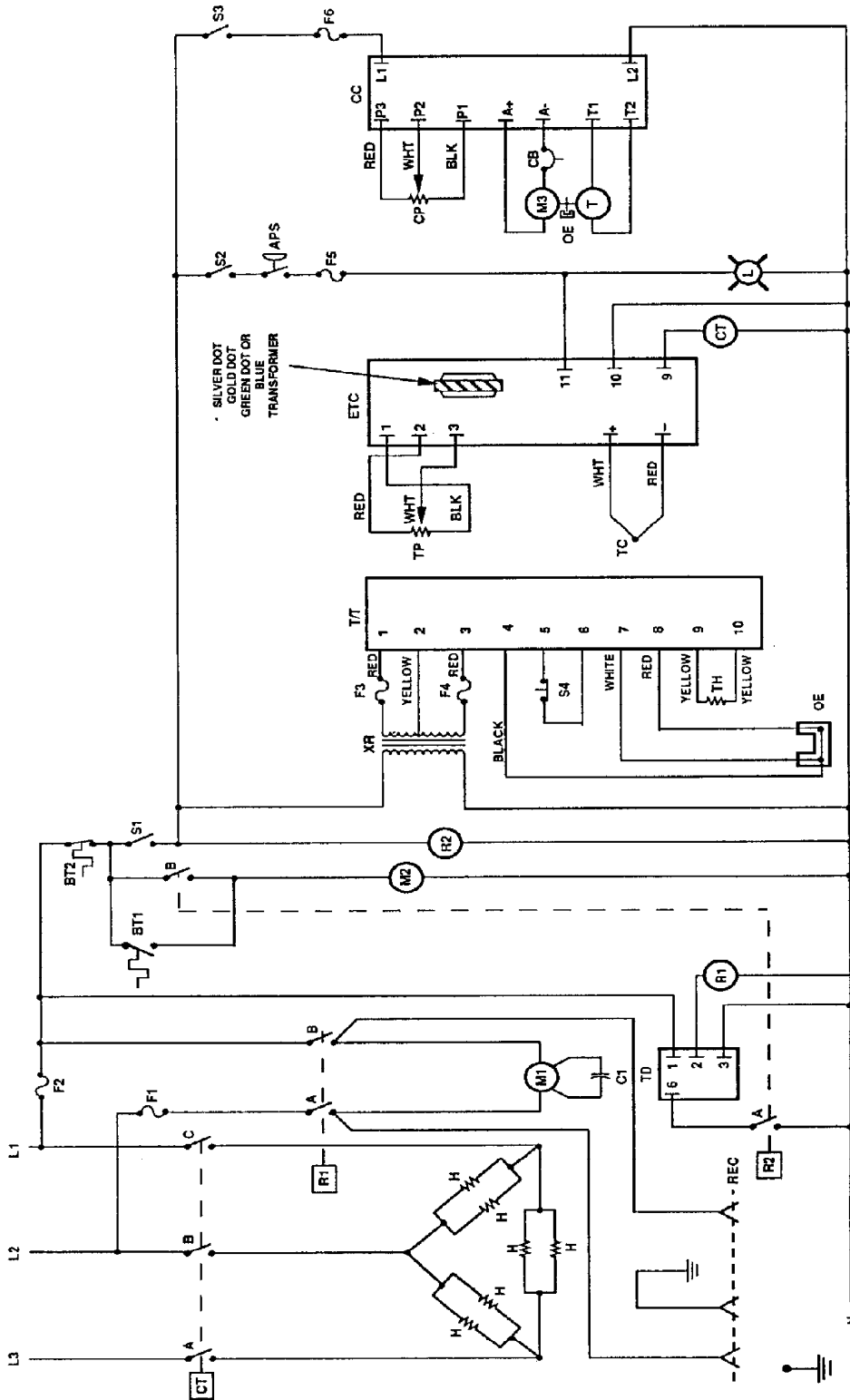

* Units with serial number 200620 and below were originally equipped with a thermal temperature control which is deleted from parts inventory. Replace with board 368723 plus a new potentiometer, part number 348620. See Section D for conversion and adjustment instructions.

NOTE: UMG 05 1162, 1163 00K;
REC - Replace; 20 AMP, 250 V NEMA LS-20

- S1 - SWITCH, MAIN FAN, SPST
- S2 - SWITCH, HEATING, SPST
- S3 - SWITCH, HEATING, SPST
- S4 - SWITCH, DISPLAY, SPST
- T - TACHOMETER
- TD - TIME DELAY, 20 MINUTE
- TC - THERMOCOUPLE
- TH - THERMISTOR
- TP - POTENTIOMETER, 0.5 K OHMS
- TT - DISPLAY, TIME/TEMP
- XR - TRANSFORMER, 12.5 VAC

- F2 - FUSE, 10 AMP, MAIN FAN MOTOR AND CONTROLS
- F3 - FUSE, 4 AMP
- F4 - FUSE, 3 AMP, TRAMP CONTROL
- F5 - FUSE, 3 AMP, CONVEYOR CONTROL
- F6 - FUSE, 3 AMP, HEATING CONTROL
- L - LAMP, PILOT, HEATING CIRCUIT
- M1 - MOTOR, MAIN FAN
- M2 - MOTOR, COOLING FAN
- M3 - MOTOR, COOLING FAN
- OE - DISPLAY UNDOOR
- R1 - RELAY, MAIN FAN, 20ST
- R2 - RELAY, COOLING FAN

- APS - SWITCH, AIR PRESSURE
- BT1 - THERMOSTAT, COOLING FAN
- BT2 - THERMOSTAT, OVEN CAVITY, HIGH LIMIT
- CA - CIRCUIT BREAKER, MAIN FAN MOTOR
- CC - CONTROL BOARD, D.C. MOTOR
- CP - POTENTIOMETER, 0.5 K OHMS, 10 TURN
- H - HEATING ELEMENTS
- R1 - RELAY, MAIN FAN, 20ST
- R2 - RELAY, COOLING FAN
- R3 - RELAY, MAIN FAN, 10ST
- R4 - RELAY, COOLING FAN

MODELS 1132, 1133, 1162 and 1163

SCHEMATIC 1132 - 1133 S/N 2011384 & ABOVE

MODELS 1132-1133

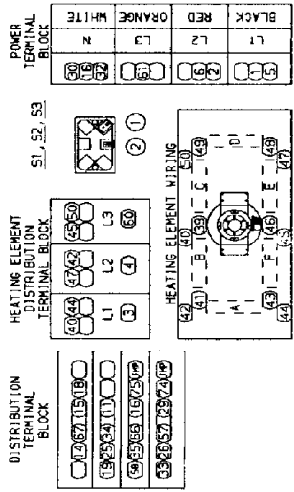
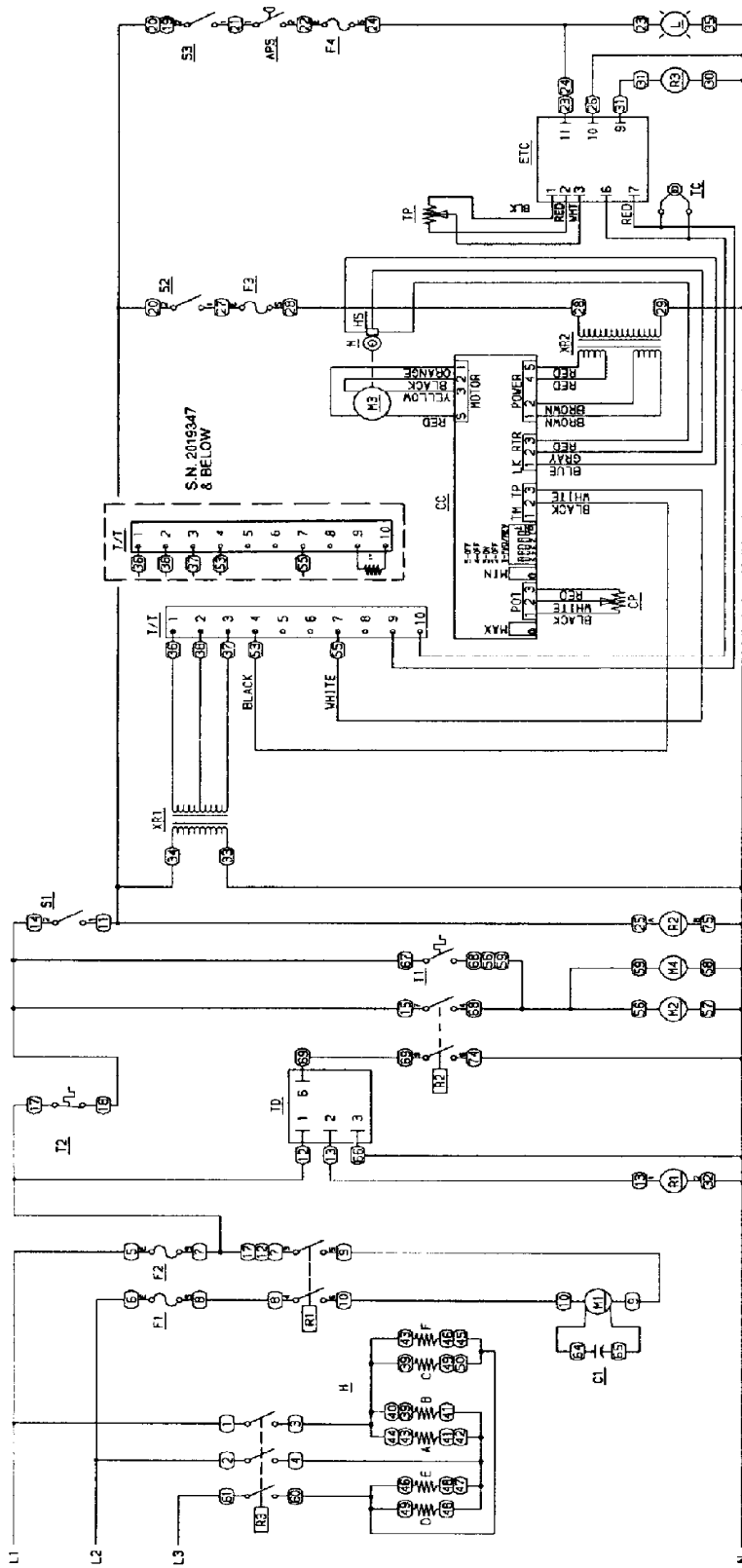

- R1 - RELAY, OVEN FAN MOTOR
- R2 - RELAY, OVEN START & COOL DOWN
- R3 - CONTACTOR, REFRIG
- S1 - SWITCH, OVEN HEAT
- S2 - SWITCH, CONVEYOR
- S3 - SWITCH, OVEN HEAT
- T1 - THERMOSTAT, CONTROL BOX COOLING
- T2 - THERMOSTAT, HIGH LIMIT
- TC - THERMOCOUPLE, TYPE J
- TD - TIMER DELAY, 20 MINUTES
- TP - TEMPERATURE POT ASSEMBLY
- T1 - THERMOCOUPLE, TYPE J
- TR - TRANSFORMER, 115V/250V
- X2 - TRANSFORMER, CONVEYOR
- WIRE NUMBERS

- APS - AIR PRESSURE SWITCH
- C1 - CAPACITOR, 7.5 MFD
- CC - CONVEYOR CONTROL
- ETC - ELECTRIC TEMPERATURE CONTROL
- F1, F2 - FUSE, FAN MOTOR, 10A
- F3 - FUSE, CONVEYOR CONTROL, 3A
- F4 - FUSE, TEMPERATURE CONTROL, 3A
- H5 - HEATING ELEMENTS, 1600W (6 PCS)
- L - LAMP, HEATER INDICATOR
- M1 - MAGNET, OVEN FAN
- PC - MOTOR, COOLING FAN
- M2 - MOTOR, CONVEYOR

TROUBLESHOOTING GUIDE 1116 - 1117

GAS OVENS

MODEL 1116 / NATURAL GAS / 120VAC / 60 HZ / 1 PHASE

MODEL 1117 / L.P. GAS / 120VAC / 60 HZ / 1 PHASE

REFER TO PROPER SCHEMATIC FOR IDENTIFIED COMPONENTS

SYMPTOM	POSSIBLE CAUSE	EVALUATION
Oven fan will not run	Incoming Power Supply	Check breakers/Reset if required Check power plug to be sure it is firmly in receptacle. Measure incoming power/call Power Co. if needed.
	Main Fan Switch	Check continuity between switch terminal.
	20 Minute Time Delay	Check for 120 VAC at terminal #1 to neutral on 20 minute Time Delay Relay. If no voltage is present, trace wiring back to power source. If voltage is present at terminal #1, check for 120 VAC at terminal #2 to neutral. If no voltage is present, and Main Fan Switch is closed, replace Time Delay
	Main Fan Relay	Check for 120 VAC to coil of the Relay, if no voltage is present, trace wiring back to 20 minute Time Delay Relay. If voltage is present, check to insure contacts are closing.Fuse, 10 Amp Check, replace if necessary
	Fuse Holder	Check, replace if necessary.
	Main Fan Motor	Check for opens, shorts, or grounds. <u>WITH POWER OFF</u> : turn fan blade to check for locked rotor.
	Capacitor	Check for shorts or grounds. WARNING : Capacitor has a stored charge, discharge before testing.
No main fan cool down	20 Minute Time Delay Relay	Check for 120 VAC at pin #2 and #3 while main fan is running. Turn off main fan switch and 120 VAC should continue to be present for 20 minutes at terminal 2. Check if relay is operating and terminals are remaining closed for main fan cool down of 20 minutes NOTE : The time delay relay will keep the coil of main fan closed, maintaining main fan operation for cool down for approximately 20 minutes.
Main fan runs after 20 minute cool down	Main Fan Relay	
20 minute cool down	Time Delay Relay	
No control box cooling	Incoming Power	Check main circuit breakers, reset if required, call power company if needed.
	Main Fan Switch	Check continuity between switch terminals.
	20 Minute Time Delay	With fan switch on, check for 120 VAC at terminal 2 of Time Delay.
	Main Fan Relay	Check continuity of 120 VAC coil. Check for power to the relay coil (120 VAC).
	Cooling Fans	120 VAC should now be at the fan motors. If voltage is present, check motors for shorts or opens WITH POWER OFF : Check for locked rotor.

Cooling fans continue to run after 20 minute cool	Cooling Fan Thermostat	Thermostat should close at 120°F± 5°F and open at 100°F± 5°F.
	Main Fan Relay	Check to insure that contacts of main fan relay are opening after 20 minute cool down
Oven will not heat	Gas Supply	Check for adequate gas supply and manual gas shut off valve is open. Also, check flexible gas line connection.
	Main Fan	If not operating, refer to "Oven fan will not run".
	Heat Switch	Check for continuity, replace if necessary
	Fuse 10 amp	Replace if necessary.
	Fuseholder	Replace if necessary
	Centrifugal Switch of Main Fan Motor	Check for 120 VAC at lead #47 (located at 6 pin connector in raceway near the main fan motor) to neutral. If no voltage is present, and motor is running, replace motor.
	(Oven Cavity) High Limit	Terminals are normally closed, opens at Thermostat 660°F (350°C). If open, push in reset button and retest. If thermostat will not hold for maximum oven temperature, and oven is not exceeding temperature dial setting, check for proper location of capillary bulb in its spring holder. If above checks okay, replace hi-limit thermostat.
	Burner Blower Motor	Visually check to see if motor is running. If not, check for 120 VAC to motor at motor connector (wire #40 and #41). If voltage is not present, trace wiring back to oven cavity High Limit. If voltage is present and motor is not running, check for opens, shorts, or grounds. Also, WITH POWER OFF: check for locked rotor.
	Control Box High Limit thermostat NOTE: Discontinued S/N 2011383	Terminals are normally closed, and open at 170°F ± 5°F (76.6°C ± 2.8°C). Check for proper operation. If it will not reset and hold, replace thermostat.
	Centrifugal Switch of Burner Blower Motor	Check for 120 VAC at motor connector wire #42 to neutral. If voltage is not present, trace wiring back to control box High Limit. If voltage is present, check #43 to neutral. If voltage is not present and motor is running, replace the Burner Blower Motor.
	Burner Transformer	Primary is 120 VAC with 24 VAC secondary. If 120 VAC is not present, trace wiring back to Burner Blower Centrifugal Switch. If 120 VAC is present, check for 24 VAC at secondary of transformer. If no voltage is present, replace transformer.
	Ignition Control	Note: The ignition control contains a safety lock-out circuit. If a flame is not detected within 6 seconds after the gas control valve is energized, the ignition control will lock-out. To reset, turn the burner switch "off", wait 45 seconds and switch the burner system "on" to retry ignition. 24 volts should be present at 24 volt terminals. If not present, trace wiring back to burner transformer. When 24 VAC is supplied, the control switches 120 VAC from L1 and L2 to the Hot Surface Ignitor. If 120 VAC is not present at L1 and L2, trace wiring back to oven cavity High Limit Thermostat. If 24 VAC and 120 VAC are present and 120 VAC is not across the Hot Surface Igniter terminals, replace the ignition control

	Hot Surface Igniter	If 120 VAC is present at Hot Surface Igniter terminals, visually check to see that the igniter is heating. (Igniter may be viewed through the port glass in end of the burner tube.) The Igniter should glow bright red. If the igniter does not heat, replace the Igniter.
	Ignition Control	After 45 seconds of hot surface igniter pre-heat, the ignition control will switch 24 VAC to the gas control valves. Check for 24 VAC output from ignition control, across terminals marked "valve" and "valve ground". If no voltage is present, replace ignition control
	Gas Control Valves	When 24 VAC is supplied to the gas control valve, the valves should open Check for gas pressure at the manifold tap located just before the burner. If there is no pressure, check the incoming gas supply to be sure all manual valves are open and flexible gas hose is properly connected. If gas is present at the oven and coils of gas valve are energized, the gas valve is defective. When 24 VAC is supplied to the gas control valve the red burner indicator.
Flame will not stay lit	Hot Surface Igniter/ Flame Sensor	Six seconds after the gas valve opens, ignition must occur. If flame is not detected, the ignition control will shutoff and lock out. To reset the ignition control, turn off the burner switch for 45 seconds then turn on the burner switch to retry ignition. The ignition control requires a minimum of 0.8 D.C. microamps To check flame sensing operation, connect a digital multimeter (capable of measuring D.C. micro-amps) between the "ground" terminal on ignition control and the ground lead. NOTE: This is a current measurement and the meter must be connected in series. If these readings are not achieved, check bypass orifice for obstructions. If bypass orifice is clear, replace the hot surface igniter/flame sensor. NOTE: The D.C. micro amp test must be conducted with the oven in low flame (bypass) operation. Turn the temperature control to the lowest setting.
	Power Supply	If there is sufficient micro-amp current, but the flame will not stay lit, check for proper polarity of the 120 VAC power supply.
	Ignition Control	If there is sufficient micro-amp current, and the 120 VAC polarity is correct, but the flame will not stay lit, replace ignition control. NOTE: check for proper ground connection on ignition control.
Low flame is on, but no main flame	NOTE: flame should be present at this time	Check for 120 VAC at terminal #11 to neutral on temperature control. If no voltage, trace voltage back to Centrifugal Switch.
	Temperature Control	Turn the temperature adjustment knob to maximum temperature position and check for 120 VAC at the load terminal (#9) and neutral. If 120 VAC is present and unit is not heating, refer to "Temperature Solenoid Valve" for next check. If 120 VAC is not present, proceed.

	Thermocouple Probe	WITH POWER ON AND THERMOCOUPLE LEADS ATTACHED TO THE TEMPERATURE CONTROL BOARD: Measure the D. C. millivolt output of these leads. Refer to thermocouple chart on page 36 for proper readings. If these readings are not achieved, replace the thermocouple
	Temperature Control Potentiometer	WITH POWER OFF: remove the potentiometer leads from the temperature control board and measure ohms from black to white leads. The reading should be from approximately 0 to 2.5 K ohms as the dial of the potentiometer is turned throughout its full rotation. From black to red leads, the reading should be approximately 2.5 K ohms (constant) throughout the full rotation of the dial. If these readings are not achieved, replace potentiometer. If the thermocouple probe and the control potentiometer check good, then the problem is usually with the temperature control board.
	Temperature Solenoid	If 120 VAC is present on the Valve temperature control board at load terminal (#9) to neutral, check for voltage at temperature regulation valve. If voltage is present, listen for valve to open and close. Also check for opens or shorts in the coil. Replace as necessary.
Intermittent Heating	Thermal/Overload of Main Fan and Burner Blower Motors	

Conveyor will not run REFER TO PAGE 26

From S/N 2011383 and up REFER TO PAGE 29

Conveyor speed varying or intermittent REFER TO PAGE 26

From S/N 2011383 and up REFER TO PAGE 29

Time/Temp Display inoperative REFER TO PAGE 27

From S/N 2011383 and up REFER TO PAGE 29

Temp Display out or erratic REFER TO PAGE 27

From S/N 2011383 and up REFER TO PAGE 29

TROUBLESHOOTING GUIDE 1100 THRU 1103

ELECTRIC OVENS

MODEL 1100 / 120/208 VAC / SINGLE PHASE / 60 HZ
 MODEL 1101 / 120/240 VAC / SINGLE PHASE / 60 HZ
 MODEL 1102 / 120/208 VAC / THREE PHASE / 60 HZ
 MODEL 1103 / 120/240 VAC / THREE PHASE / 60 HZ

REFER TO PROPER SCHEMATIC FOR IDENTIFIED COMPONENTS

SYMPTON	POSSIBLE CAUSE	EVALUATION
Oven fan will not run	Incoming Power Supply	Check circuit breakers. Reset if required. Call Power Co. needed.
	Fuses, 10 Amp,	Check, replace if necessary
	Fuseholder	Check, replace if necessary
	Switch, Main Fan	Check for continuity between switch terminals.
	Main Fan Relay	Check continuity of 120 VAC coil. Check for power to relay coil (120 VAC). Check for 208/240 VAC to the relay terminals
	Main Fan Motor	Check for opens, shorts, or grounds. WITH POWER OFF: Turn fan blade to check for locked rotor
No control box cooling	Capacitor	Check for opens, shorts, or grounds.
		Check for main fan operation. If not operating, refer to "Oven fan will not run". Cooling Fan Motor 120 VAC should be present at the fan motor. If voltage is present, check for opens or shorts. WITH POWER OFF: Check for locked rotor of the fan motor.
No main fan cool down	Cool Down Thermostat	Check cool down thermostat (thermostat closes at 160°F and opens at 140°F). Check for power (120 VAC) at cool down thermostat. With cool down thermostat preheated, check for continuity. If switch is open, replace.
Oven will not heat	Main Fan Motor	Check for main fan operation. If it is not operating, refer to "Oven fan will not run".
	High Limit Thermostat, Oven Cavity	Terminals are normally closed. If open, reset the thermostat and test for proper operation. If it will not reset and hold, then replace.
	Switch, Heat	With switch on, check for 120 VAC on both terminals to neutral. Replace if defective
	Air Pressure Switch	This normally open switch should close when the main fan is activated. If adjustment is necessary (Refer to Section D). Replace if defective.
	Fuse, 3 Amp	Check, replace if necessary.
	Fuseholder	Check, replace if necessary
	Temperature Control	Check for 120 VAC supply at terminal #11 to neutral on temperature control. If no voltage is present, trace wiring back to 3 amp fuse. Turn the temperature adjustment knob to maximum temperature position and check for 120 VAC at the load terminal (#9) and neutral. If 120 VAC is present and unit is not heating, refer to "Mercury Contactor" for next check. If 120 VAC is not present, proceed.
	Thermocouple Probe	WITH POWER ON AND THERMOCOUPLE LEADS ATTACHED TO THE TEMPERATURE CONTROL BOARD: measure D. C. millivolt output of these leads. Refer to thermocouple chart on page 36 for proper readings. If these readings are not achieved, replace thermocouple.

	Temperature Control Potentiometer	WITH POWER OFF: remove the potentiometer leads from the temperature control board and measure ohms from black to white leads. The reading should be from approximately 0 to 2.5k ohms as the dial of the potentiometer is turned throughout its full rotation. From black to red leads, the reading should be approximately 2.5k ohms (constant) throughout the full rotation of the dial. If these readings are not achieved, replace potentiometer. If the thermocouple probe and the control potentiometer checks good, then the problem is usually with the temperature control board.
	Mercury Contactor	Check for 120 VAC to the contactor coil. If voltage is present and contact will not activate, replace the contactor. Also, check each contactor for proper high voltage input and output
	Heater Elements	Check the Amp. draw on each leg for proper load. Check the specification plate for rating information. If the Amp. draw is low or high, check the individual elements for opens, shorts, and proper resistance. WITH POWER OFF: check resistance of the elements, remove all leads from the elements and use an accurate digital VOM. The element resistance should be as follows: 208V - 27 ohms approximately, 240V - 36 ohms approximately.
Oven heats with switch off	Mercury Contactor	The mercury contactor has probably malfunctioned in the closed position. If there is no voltage to the operating coil, but there is high voltage at the contactor output, replace the mercury contactor.
Intermittent Heating	Thermal/Overload of motor	The main fan motor is equipped with internal thermal protection and will cease to operate if overheating occurs. As the motor overheats and then cools, this will cause the ovens to cycle on and off intermittently. This may be caused by improper ventilation or preventative maintenance. Also, most of the problems listed under "Oven will not heat" can cause intermittent failure.

Conveyor will not run / REFER TO PAGE 26

Conveyor speed varying / REFER TO PAGE 26
or intermittent

Time/Temp Display / REFER TO PAGE 27
inoperative

Temp Display out or / REFER TO PAGE 27
inaccurate

TROUBLESHOOTING GUIDE 1130 THRU 1133 / 1160 THRU 1163

ELECTRIC OVENS

MODEL 1130, 1160 / 120/208 VAC / SINGLE PHASE / 60 HZ
 MODEL 1131, 1161 / 120/240 VAC / SINGLE PHASE / 60 HZ
 MODEL 1132, 1162 / 120/208 VAC / THREE PHASE / 60 HZ
 MODEL 1133, 1163 / 120/240 VAC / THREE PHASE / 60 HZ

REFER TO PROPER SCHEMATIC FOR IDENTIFIED COMPONENTS

SYMPTON	POSSIBLE CAUSE	EVALUATION
Oven fan will not run	Incoming Power Supply	Check circuit breakers. Reset if required. Call Power Co. if needed. NOTE: On Models 1160, 1161, 1162 and 1163, disconnect any accessory from receptacle in the rear of the oven and check for shorts or overloads.
	Fuses, 10 Amp, Fuseholder	Check, replace if necessary Check, replace if necessary
	High Limit Thermostat, Oven Cavity	Terminals are normally closed. If open, reset the thermostat and test for proper operation. If it will not reset and hold, replace thermostat.
	Switch, Main Fan	Check for continuity between switch terminals.
	Relay, Oven Start	Check for continuity at relay coil, and visually check for pull in of contacts.
	20 Minute Time Delay	Check for 120 VAC at terminal #1 to neutral on 20 minute Time Delay Relay. If no voltage is present, trace wiring back to 10A fuse. If voltage is present at terminal #1, check for 120 VAC at terminal #2 to neutral. If no voltage is present, and oven start relay is closed, replace Time Delay.
	Main Fan Relay	Check for 120 VAC to coil of the Relay. If no voltage is present, trace wiring back to 20 minute Time Delay Relay. If voltage is present, check to insure contacts are closing.
	Main Fan Motor	Check for opens, shorts, or grounds. WITH POWER OFF: Turn fan blade to check for locked rotor.
	Capacitor	Check for opens, shorts, or grounds
No main fan cool down	20 Minute Time Delay	Check for 120 VAC at terminal #2 to neutral while oven is "on". Turn off the main fan switch, 120 VAC should continue to be present for 20 minutes. If voltage is not present for approx. 20 minutes, replace the timer.
	Oven Fan Relay	Check if relay is operating and that the contacts remain closed during the 20 minute cool down.
Main fan runs after 20 minute cool down	Oven Start Relay	Contacts should open when main fan switch is turned off.
	20 Minute Time Delay	120 VAC at terminal #2 should discontinue approximately 20 minutes after main fan is switched off. If the oven start relay contacts are open, and the voltage continues at terminal #2 of the 20 minute timer, for more than 20 minutes, replace the timer.
	Oven Fan Relay	Check to insure that the contacts are opening after the coil is de-energized
	20 Minute Time Delay	NOTE: ON/OFF operation of the fan switch will set the timer to 20 minutes. If the timer is accidentally reset, turn off main breaker for 15 seconds to cancel

No control box cooling		Check for main fan operation. If not operating, refer to "Oven Fan Will Not Run".
	Oven Start Relay	Check relay contacts. 120 VAC should be present.
	Cooling Fan Motor(s)	120 VAC should be present at the fan motor. If voltage is present, check for opens or shorts. WITH POWER OFF: Check for locked rotor of the fan motor.
No automatic control	Thermostat, Cooling	Check the cooling fan thermostat. box cooling Fan (Thermostat closes at 120°F and opens at 100°F.). With the cooling fan thermostat pre-heated, check for continuity. If switch is open, replace.
	Cooling Fan Motor(s)	120 VAC should be present at the fan motor. If voltage is present, check for opens or shorts. WITH POWER OFF: check for locked rotor of the fan motor.
Control box cooling fan continues to run	Thermostat, Cooling Fan	This normally open thermostat should close at 120°F (48.9°C) and reopen at 100°F (37.8°C).
Oven will not heat	Main Fan Motor	Check for main fan operation. If it is not operating, refer to "Oven fan will not run".
	Heat Switch	With switch on, check for 120 VAC on both terminals to neutral. Replace if defective.
	Air Pressure Switch	This normally open switch should close when the main fan is activated. Adjust if necessary (Refer to page 23). Replace if defective.
	Fuse, 3 Amp	Check, replace if necessary
	Fuseholder	Check, replace if necessary
	Temperature Control	Check for 120 VAC supply at terminal #11 to neutral on temperature control. If no voltage is present, trace wiring back to 3-amp fuse. Turn the temperature adjustment knob to maximum temperature position and check for 120 VAC at the load terminal (#9) and neutral. If 120 VAC is present and unit is not heating, refer to "Mercury Contactor" for next check. If 120 VAC is not present, proceed.
	Thermocouple Probe	WITH POWER ON AND THERMOCOUPLE LEADS ATTACHED TO THE TEMPERATURE CONTROL BOARD: measure D. C. millivolt output of these leads. Refer to thermocouple chart on page 36 for proper readings. If these readings are not achieved, replace thermocouple.
	Temperature Control Potentiometer	WITH POWER OFF: remove the potentiometer leads from the temperature control board and measure ohms from black to white leads. The reading should be from approximately 0 to 2.5k ohms as the dial of the potentiometer is turned throughout its full rotation. From black to red leads, the reading should be approximately 2.5k ohms (constant) throughout the full rotation of the dial. If these readings are not achieved, replace the potentiometer. If the thermocouple probe and the control potentiometer check good, then the problem is usually with the temperature control board.
	Mercury Contactor	Check for 120 VAC to the contactor coil. If voltage is present and the contactor will not activate, replace the contactor. Also, check each contactor for proper high voltage input and output.
	Heater Elements	Check the Amp. draw on each hot leg for proper load. Check the specifications plate for rating information. If the Amp. draw is low or high, check the individual elements for opens, shorts, and proper resistance. WITH POWER OFF: To check resistance of the elements, remove all leads from the elements and use an accurate digital VOM. The element resistance should be as follows: 208V - 27 ohms approximately

		240V - 36 ohms approximately.
Oven heats with switch off	Mercury Contactor	The mercury contactor has probably malfunctioned in the closed position. If there is no voltage to the operating coil, but there is high voltage at the contactor output, replace the mercury contactor.
Intermittent Heating	Thermal/Overload of Motor	The main fan motor is equipped with internal thermal protection and will cease to operate if overheating occurs. As the motor overheats and then cools, this will cause the units to cycle on and off intermittently. This may be caused by improper ventilation or preventative maintenance. Also, most of the problems listed under "Oven will not heat" can cause intermittent failure.
Conveyor Will Not Run	Conveyor Switch	Check for continuity between switch terminals
	3 Amp Fuse	Check, replace as needed
	Fuseholder	Check, replace as needed
S/N 2011383 and above 1130 through 1133 – S/N 2011978 and above Models 1160 through 1163 Refer to Page 29	Speed Adjustment Potentiometer	This is a 0 to 5 K ohm, 10 turn potentiometer. WITH POWER OFF: Remove the red, black and white pot leads from the motor control board at terminals P1, P2 and P3. With a digital multimeter, check the ohm reading across the red lead (P3) to the black lead (P1). This reading should be 5 K ohms \pm 5% as the pot is rotated from low to high. Place the meter leads on the red lead (P3) and on the white lead (P2) Rotating the pot. slowly, from low to high, the meter reading should show an even transition from 0 to 5 K ohms \pm 5%. There should be no dead or open spots through out the 10 turns of the pot. Check all three leads to ground. There should be no continuity to ground. If any of the above checks fail, replace the pot.
	DC Motor Control Board	Check for 120 VAC input to the control board at terminals L1 and L2. If not present, check the conveyor switch and wiring back to 3 amp fuse and then back to power source if necessary. If 120 VAC is present at L1 and L2, check the VDC output at terminals A+ and A-. If a DC voltage is not present, check the 4 amp and the 1 amp fuses on the control board. If 120 VAC is present at terminals L1 and L2, but DC Voltage is not present at A+ and A-, providing the fuses are good, replace the board. If DC voltage is present at A+ and A-, but motor does not run, check gear motor as follows.
	Conveyor Gear Motor	If DC voltage is present at A+ and A- and the motor does not run, first check the mini breaker and then the conveyor. As described below under "conveyor." WITH POWER OFF: Check the leads to the motor for evidence of any shorts or opens, and each lead to ground. Remove dust cover from the top of the motor and rotate motor shaft to determine if there is a locked rotor or a locked gear box (use care so encoder disc is not damaged). If the motor fails the above tests, replace motor.
	Conveyor	Check for any mechanical misalignment or improper adjustment. Also check for worn bearings. The Installation and Operations Manual shows proper conveyor belt position. A conveyor belt that is too tight will contribute to excessive load, bearing wear, and wearing of slider bed rods.
Conveyor speed varying or intermittent	Power Supply	Check power supply at the DC control board for the 120 VAC at board terminals L1 and L2. If voltage is not present and steady, check the main circuit

		breakers and call power company if necessary.
S/N 21011383 and above Models 1130 through 1133 – 2011978 and above Models 1160 through 1163 – Refer to page 29	Tach. generator and DC Motor Control Board	WITH POWER OFF: Remove the leads from terminals T1 and T2. Place the test leads of a digital test meter on the tach. leads, turn power on, and the meter reading should be approximately 20 to 25 VDC. This reading is normally steady within ± 0.2 to 0.3 VDC. If this reading is not within required VDC, place the test meter probes on terminals A+ and A-. The meter reading should be approximately 150 to 160 VDC and steady within approximately 4 to 5 VDC. If the tach. voltage is unsteady, and the board output is steady, check the coupling for loose set screws or any type of damage. If the coupling checks good, the tach. is usually bad. If the board voltage output is unsteady beyond limits, then the board is probably bad. Always check the speed pot. Be sure it is okay before changing a board or tach. This test is not always 100% accurate as this test is not performed at operating speeds. However, this test is the best method currently available. Readjustment should always be attempted at least once before replacement. See procedure for board adjustment on page 41.
	DC Gearmotor	If the problem seems to be the motor or gearbox. Check the brushes in the motor for excessive arching and/or unusual wear. Check the motor and gearbox from instruction located on page 26 under "possible cause" listing "Conveyor gear motor".
Time/Temp Display inoperative S/N 2011383 and above Models 1130 through 1133 Refer to Page 29	12.6 VAC Power Supply	Measure the transformer primary for a nominal 120 VAC input. Measure the secondary voltage output which will be 12.5 to 15 VAC normally. Recheck secondary output at rear of Time/Temp Display. Terminals 1 to 3 should read 12.5 to 15 VAC. Terminals 1 to 2 and 2 to 3 should be 1/2 of the reading across 1 to 3. If you do not get the above secondary readings, replace the transformer. If 120 VAC primary voltage is not available, refer to the schematic and trace circuit for incoming power failure. The older units have a 4 amp ambient fuse in each red secondary lead. These may be jumpered to determine if they are burnt out or intermittent.
Temp Display out or inaccurate	NOTE: Time/Temp displays use two types of temperature sensors thermistor probe-2 yellow wires, thermocouple probe-1 red wire and 1 white wire	Insert the thermocouple of your pyrometer into a finger hole in the top center of the oven. Be sure the tip of the thermocouple is not touching metal. The pyrometer will indicate oven temperature.
From S/N 2011383 and up Models 1130 through 1133 S/N 2011978 and up Models 1160 through 1163 Refer to Page 29	Thermistor Probe	Disconnect the yellow tipped thermistor leads from the time/temp. terminals 9 and 10. Measure the resistance of the thermistor probe and temperature of oven. See the chart on page 44 for proper resistance readings. Inspect the thermistor bulb for its proper location in its spring holder. Check for short in leads where they enter the sensor bulb. Also check each thermistor lead for short to ground.

	Thermocouple Probe	Place your pyrometer thermocouple into the center of top finger. Connect temperature meter to thermocouple at terminals 9 & 10 on back of the time/temp display. (Be sure to maintain proper polarity on thermocouple connections.) Compare actual oven temperature with the reading at the time/temp display. If the temperature readings match, re-calibrate or replace time/temp display. If the readings do not match, replace thermocouple probe.
	Erratic time/temp display	If strange or unusual behavior is experienced such as a rolling of numbers, or lock up at a given number, first check for a display circuit lock up. This can be caused by a voltage spike or surge in the incoming power lines. To eliminate this condition remove power from the time/temp. display by shutting off the main fan switch for 15 seconds, or if display stays on, (older models) circuit breaker interruption may be required. This should eliminate the problem. If the problem continues, jumper the two fuses in the red wires leading from the 12.6 VAC transformer to the display on older units. If this does not solve the problem, it may be coming in through the commercial power lines. Suggest that customer contact his power company for evaluation.
	Temp Display inaccurate, erratic or inoperative	Perform the power supply check, the thermistor probe check, and then perform the time/temp simulator test. Refer to Removal, Installation, and Adjustment section for instructions (see page 42). Remember, when using the time/temp simulator, remove all the leads from the back of the display except the 3 power leads. After completion of this test and if reinstalling display back into the oven, the dip switches must be reset for oven operation.
	Time Display inaccurate, erratic	Perform all checks as in the above evaluation. If the time check is okay, or inoperative refer to the next section, optical encoder.
	Optical Encoder	The above time/temp test should have already been performed. Remove dust cover from the gear motor and inspect the coupling and encoder disc. The coupling set screws should be tight and not slipping on the motor shaft or the tach. generator shaft. The encoder disc should be firmly attached to the coupling and not warped. Check the positioning of the optical encoder disc. The disc should not be touching the optical encoder assembly and the encoder assembly should be mounted so it is squarely facing the coupling shaft. This is to allow the infrared light beams to be broken by the encoder disc. If all this is okay, then replace the optical encoder assembly.

STEPPER MOTOR DRIVE

Conveyor will not run	Conveyor Switch	Check for 120 VAC to conveyor switch. If no voltage is present, trace wiring back to the oven power source. WITH POWER OFF: Check continuity between switch terminals.
	Conveyor Fuse 3AMP	Check, replace if necessary. (Not used on Model 1151)
	Fuseholder Conveyor Control (Stepper) Transformer	Check, replace if necessary. Check for 120 VAC supply to primary of transformer, if voltage is not present, trace wiring back to the fuseholder. If voltage is present, check for output voltage from the transformer secondary. NOTE: This control transformer outputs (2) secondary voltages. Red Leads 29 VAC Brown Leads 10 VAC If BOTH secondary voltages are not present, replace the transformer.
	Speed Adjustment Potentiometer	This is a 0 to 50k ohm, 10 turn potentiometer. WITH POWER OFF: remove the 3 pin potentiometer cable plug from the motor control board. With a digital multimeter, check the ohm reading across the red lead to the black lead, this reading should be 50k ohms \pm 5% as the potentiometer is rotated through its 10 turn rotation. Place the meter leads on the red lead and white lead. Rotating the potentiometer slowly, from low to high, the meter should show an even transition from 0 to 50k ohms \pm 5% through the 10 turn rotation of the potentiometer. There should be no dead or open spots through the 10 turns of the potentiometer. Check all three leads to ground. There should be no continuity to ground. If any of the above checks fail, replace the potentiometer.
	Conveyor Motor (Stepper) Control	NOTE: if the conveyor drive motor becomes jammed, the motor will stop turning. To reset, turn off conveyor switch, wait 10 seconds and turn the conveyor switch on. If the motor does not run, check for 2 to 29 VAC across the motor terminals 1 to 2 and 3 to 5 on the conveyor motor control. If voltage is not present at both sets of terminals, replace control.
	Conveyor Drive (Stepper) Motor	Check the drive sprocket on motor output shaft to insure that it is tight. WITH POWER OFF: Turn the motor shaft to check for jammed gear box. Check motor windings. Ohm readings on motor terminal -1-5, 2-6, 3-7, 4-8, each reading should be approximately 2 ohms. If motor shaft will not turn, replace conveyor drive (stepper) motor.
Time/Temp Display inoperative	12 VAC Power Supply (Transformer)	Measure the transformer primary for a nominal 120 VAC input, if voltage is not present, trace wiring back to the oven power source. Measure the secondary output, which will normally be 12-15 VAC. Voltage across terminals 1 and 3 on the time/temp. display should read 12-15 VAC. Terminals 1-2 and 2-3 should be 1/2 the voltage reading to 1-3. If the above secondary readings are not achieved, replace transformer.
	Time/Temp Display	If proper voltage is present at terminals 1, 2, and 3 on time/temp display, but the display is not lighted, recheck all connections for tightness. If time/temp display is still not operating, replace the time/temp display
Temp display out or inaccurate	NOTE: Time/Temp displays use two types of temperature sensors thermistor probe-2 yellow wires thermocouple probe probe-1 red wire and 1 white wire	Place the thermocouple of a pyrometer into the center of the top finger. Be sure the tip of the thermocouple is not touching metal. The pyrometer will indicate oven temperature.
	Thermistor Probe	Disconnect the thermistor probe leads from the

		time/temp display terminals #9 and 10. Measure the resistance of the thermistor probe. See chart on page 44 showing probe resistance at various oven temperatures. If these readings are not achieved, replace the thermistor probe.
	Thermocouple Probe	Place your pyrometer thermocouple into the center of the top finger. Measure D.C. millivolts at terminals 9 and 10 on the time/temp display. See thermocouple chart on page 36 for proper readings. Connect temperature meter to thermocouple at terminals 9 & 10 on back of the time/temp display. (Be sure to maintain proper polarity on thermocouple connections.) Compare actual oven temperature with the reading at the time/temp display. If the temperature readings match, recalibrate or replace time/temp display. If the readings do not match, replace thermocouple probe.
	Power Supply	If a strange or unusual behavior is experienced, such as a rolling of numbers, or lock-up at a given number, first check for a display circuit lock-up. This may be caused by a voltage spike or surge in the incoming power lines. To eliminate this condition, remove power from the time/temp display by shutting off the main fan switch for 15 seconds. This should eliminate the problem. If this does not solve the problem, it may be coming in through the Commercial power lines. Suggest that customer contact their power company for evaluation.
Temp display inaccurate erratic, or inoperative	Time/Temp Display	Perform the power supply check, the thermistor probe check, and then perform the time/temp simulator test. Refer to page 45 for instructions. Remember, when using the time/temp simulator, remove all leads from the back of the time/temp display except the 3 power leads. After completion of the test, and if re-installing time/temp display back in the oven, the dip switches must be reset for oven operation, and the time/temp display must be re-calibrated. If readings are not achieved, replace display
Time Display inaccurate erratic, or inoperative		Perform all checks as in the above evaluation. If the time check is okay, refer to the next section.
	Conveyor Drive (Stepper) Motor	Check to see if the conveyor drive (stepper) motor is running. If motor is not running, refer to "Conveyor will not run" on page 29.
	Magnet	Check to insure that the magnet (cemented to shaft of conveyor drive [stepper] motor) has not been damaged,
	Hall Effect Sensor	Check for any physical damage to Hall Effect sensor (mounted on conveyor drive [stepper] motor). Check all wiring and connections for damage. If the motor is running, the magnet is in place, but the display shows"-- :--" the Hall Effect Sensor may be defective or improperly connected.
	Conveyor Drive (Stepper Control)	Check all connections for tightness or proper location and check all wiring for visible damage. Replace as needed. If there is still no time display and all the above have checked out, replace the stepper control.

REMOVAL, INSTALLATION, AND ADJUSTMENT

IMPINGER II CONVEYOR OVEN

MOTOR, MAIN FAN

1. Shut off power at main breaker.
2. Disconnect motor wiring of main fan motor, note wire colors for reassembly, and remove entire oven back from the oven. Refer to "main fan" (See Below) for removal information.
3. Remove the main fan.
4. Remove 4 screws from the motor support assembly.
5. Remove the motor mounting clamp and pull the motor away from the oven back assembly.
6. Remove motor mounting fixture.
7. Install the motor in reverse order insuring that the motor shaft is centered in the
8. Shaft tube of the oven back.

CAPACITOR, MOTOR

Model 1100-1106

Capacitor is located under motor cover in rear of unit and held in place by a plastic wire tie.

- 1 Discharge capacitor, remove and replace.

FOR ALL OTHER 1100 MODELS

Capacitor is located under rear control box cover and held in place by a plastic wire tie.

MAIN FAN

1. Shut off power at main breaker.
2. Remove motor cover from back of oven.
3. Disconnect and mark motor wiring of main fan motor and remove entire oven back from oven.
NOTE: Turning the oven back bolts back and forward while applying a spray lubricant or penetrating oil will help minimize breakage.
4. Loosen and remove set screw in hub of fan.
5. Remove fan. The motor shaft has a flat making removal of fan fairly easy. If trouble is encountered, apply a spray lubricant or penetrating oil in set screw hole and on motor shaft.
NOTE: This fan is balanced by the manufacturer and must be handled carefully.
Suggested storage is by suspending the fan through the shaft hole.
6. Reinstall fan with the tips of the fan blade closest to the oven back.
7. Position of the fan on the motor shaft will be 1 1/2" (3.81cm) from the top of the oven back cone to the bottom of the fan hub. Refer to drawing. The oven back must be removed to make this measurement.
8. Align set screw with motor shaft flat and tighten.
9. Reassemble in reverse order.

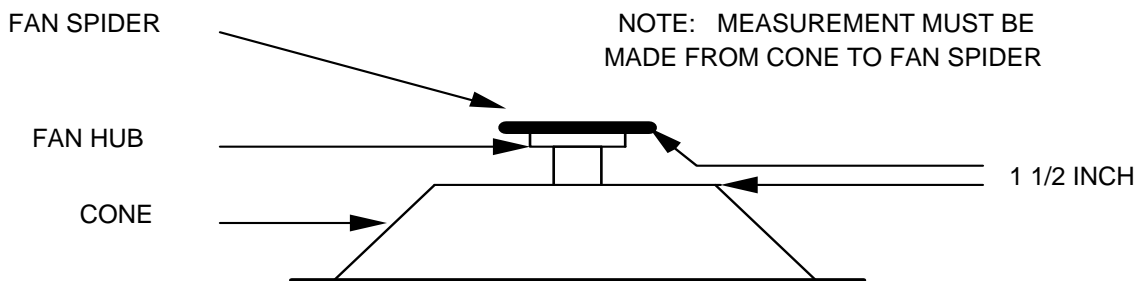

RELAY, DPST

1. Shut off power at main breaker.
2. Remove conveyor.
3. Remove control compartment covers.
4. Remove leads from relay and mark for reassembly.
5. Remove mounting screws and lift out relay.
6. Reassemble in reverse order.

TIME DELAY, 20 MINUTE

1. Shut off power at main breaker.
2. Remove conveyor.
3. Remove front control compartment cover.
4. Unplug all wires and mark for replacement.
5. Remove center mounting screw.
6. Reassemble in reverse order.

NOTE: Do not over tighten the mounting screw as this may damage the internal potted electronic components.

COOLING FAN

1. Shut off power at main breaker.
2. Remove conveyor.
3. Remove front control compartment cover.
4. Remove 4 screws from fan frame.
5. Remove fan and unplug female cord receptacle.
6. Reassemble in reverse order.

NOTE: All current models have 2 of these cooling fans.

7. The second cooling fan is located in the rear of the rear control compartment. On older models of the 1116,1117,1152 through 1158 the fan was attached to a metal box on rear of oven. Metal box was removed first. Newer ovens have fan mounted on inside of oven back and are removed from inside.

THERMOSTAT, COOL DOWN

Model 1100-1106 only

1. Shut off power at main breaker.
2. Remove conveyor.
3. Remove control compartment covers.
4. Remove 2 screws from holding bracket located in upper rear of the control compartment.
5. Remove the 2 leads and remove thermostat.
6. Reassemble in reverse order.

RELAY, DPST

1. Shut off power at main breaker.
2. Remove conveyor.
3. Remove front control compartment cover.
4. Remove leads and mark for reassembly.
5. Loosen mounting screws and remove.
6. Reassemble in reverse order.

THERMOSHETAT, COOLING FAN

1. Shut off power at main breaker.
2. Remove conveyor.
3. Remove front control compartment cover.
4. Remove lead wires and mark for reassembly.
5. Remove 2 screws and remove thermostat.
6. Reassemble in reverse order.

MOTOR, BURNER BLOWER

This unit comes equipped to be used for other models of ovens. For use on the Impinger II Series, the mating plug with the loose wires may be discarded.

TO REMOVE BLOWER MOTOR:

1. Shut off power at main breaker.
2. Remove conveyor.
3. Remove control compartment covers.
4. Disconnect the plug on blower motor. Plastic locks on side of plug need to be depressed.
5. Remove three screws holding blower horn to burner.
6. Remove air shutter from old unit and install on new unit. If air shutter of old unit is damaged or lost, replace with new air shutter [369401](#).
7. Reassemble in reverse order.
8. Adjust air shutter opening if necessary. Set air shutter at 50% open and adjust to get a blue flame with an occasional tip of yellow under high flame. A glass view port in the burner assembly should be used to observe flame.

CLEANING OF THE BLOWER FAN IS NECESSARY ON A PREVENTIVE MAINTENANCE SCHEDULE.

See Blower Wheel, Burner below

BLOWER WHEEL, BURNER

This is part of the burner blower motor assembly

TO REMOVE THE BLOWER WHEEL FOR PERIODIC CLEANING:

1. Disconnect power and remove control compartment covers.
 2. Remove air shutter held by 3 screws.
 3. Loosen set screw on blower wheel hub and pull straight out.
 4. Reassemble in reverse order.
- NOTE:** There is no critical placement of the blower wheel on the motor shaft. Just back as far as it will go and then spin the blower to be sure it is not rubbing.

AIR PRESSURE SWITCH

1. Shut off power at main breaker.
2. Remove conveyor.
3. Remove front control compartment cover.
4. Remove air switch cover plate.
5. Disconnect wiring and mark for reassembly.
6. Loosen 2 screws and remove air switch.
7. Disconnect 1/4" air tube.
8. Reassemble in reverse order.
9. Turn on power and calibrate air switch as follows:
 - a) Turn adjusting screw counter clockwise to full out position.
 - b) Turn main fan and heat switch on.
 - c) Turn adjusting screw clockwise until heat shuts off.
 - d) Turn adjusting screw (counterclockwise) 1/4 turn and unit should heat.

NOTE: Test as follows

 - e) Oven must be tested in heated condition.
 - f) Remove main fan fuse. Main fan should shut down, deactivating air switch causing heat to shut off in approximately 5 to 25 seconds.
 - g) Fine tune adjustment as needed.

TEMPERATURE CONTROL BOARD

NOTE: If your unit contains a Fenwal temperature control board, (see below) replace it with a thermologic control board.

TEMPERATURE CONTROL BOARD CONVERSION - FENWAL TO THERMOLOGIC (FOUND ONLY IN ELECTRIC UNITS BELOW S/N 2000861)

1. Remove Fenwal board.
2. Remove 5K ohm potentiometer
3. Remove wire #63 from oven. This wire is connected to Fenwal board at terminal #5.
4. Install new thermologic board with 2 screws.
5. Install new 2.5K ohm potentiometer.
6. Attach leads to thermologic board as shown in drawings. See pages 34 & 35.

Located in control compartment below drive end of the conveyor

1. Shut off power at main breaker and remove conveyor.
2. Remove front control compartment cover.
3. Remove the two mounting screws.
4. Remove the electrical leads and replace the control board.
5. Identify the style of thermologic board by looking at the top of the transformer on the board. There are five styles of boards, each identified by a color marked on the transformer, either RED, BLUE, GREEN, GOLD, OR A SILVER DOT. Refer to Pages 34 & 35 showing proper wiring connection.
6. **NOTE:** When mounting a new temperature control board, DO NOT over tighten the two mounting screws.
7. Turn the potentiometer fully counterclockwise.
8. Loosen the Dial/Knob set screw and position the 50°F mark at the pointer.
NOTE: The thermocouple of your test meter should be inserted through a finger hole in the top center of the oven, and the oven pre-heated for 30 minutes to stabilize the oven at set temperature. The thermocouple probe must not touch metal, it must sense air temperature only.
9. Adjustment of the GREEN, GOLD OR SILVER dot control board may be required when installing a new board. Adjustment is seldom required on RED and BLUE boards.
10. For RED or BLUE control boards with the temperature control dial at maximum, the reading on your temperature test meter should be between 555°F (290°C) and 575°F (302°C). If not at this temperature adjust pot P3 to achieve these figures. Refer to page 35.
11. For the GREEN, GOLD OR SILVER dot control board, place the test probe of your meter in position as indicated in prior note. Set the oven temperature control dial 500°F(260°C), adjust pot P6 (see page 34) to achieve a temperature reading on test meter of 500°F(260°C). CCW to increase, CW to decrease.
12. Adjust Time/Temp Display Pot. "Temp Cal" for 500°F(260°C).

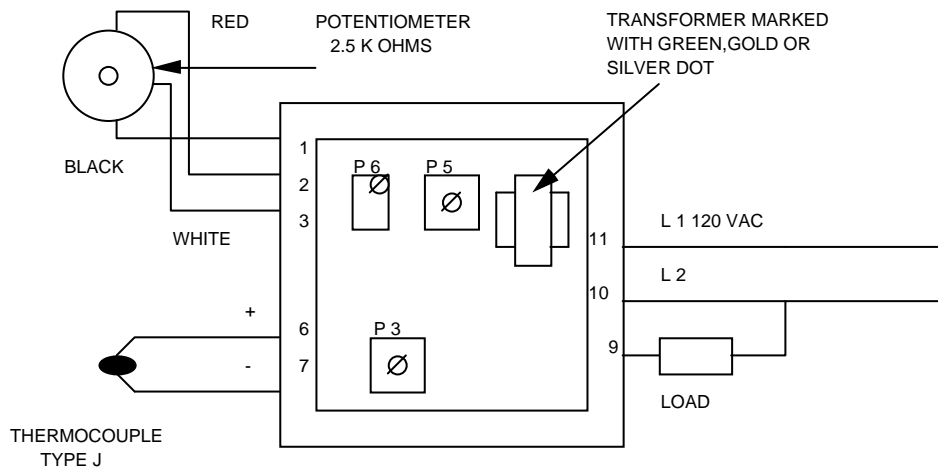

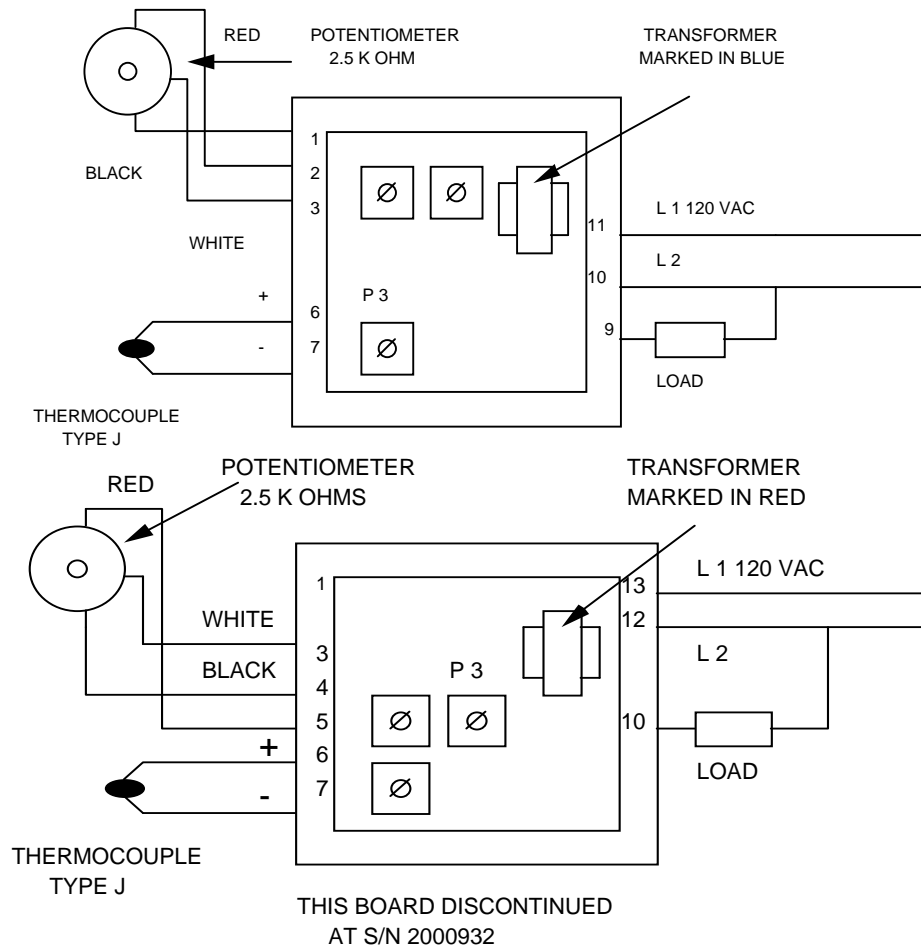

TEMPERATURE CONTROL POTENTIOMETER, 0-2.5K OHMS, 1 TURN

1. Shut off power at main breaker.
2. Remove front control box cover.
3. Loosen and remove temperature control knob.
4. Remove hex nut and washer then remove pot from rear of compartment.
5. Remove and mark wiring for replacement.
6. Replace in reverse order.
7. Recalibrate the dial. (See "Temperature Control")

THERMOCOUPLE PROBE

The sensor bulb is located in the oven compartment behind the lower finger, and held in position by a wire form holder.

CAUTION: ALLOW OVEN TO COOL

1. Shut off power.
2. Remove conveyor and lower finger.
3. Remove control compartment covers.
4. Remove sensor bulb from the wire form holder, pull thermocouple out of the oven through the access tube and disconnect leads from terminals 6 and 7 of the temperature control board.
5. To install, push thermocouple bulb through the access tube and place in wire form holder. Be sure that wire form holder is exerting enough pressure on the sensor bulb to hold it in place. If sensor bulb is not held securely, replace the wire form holder or bend the holder slightly to hold sensor bulb in place.
6. Reconnect RED lead to terminal 7(-) and WHITE lead to terminal 6(+).
7. Replace conveyor and fingers.

THERMOCOUPLE MEASUREMENT CHART:

EXPLANATION: The junction temperature is the ambient air temperature where the thermocouple fastens to the electronic temperature control board.

		O	V	E	N	T	E	M	P			
		200°F	250°F	300°F	325°F	350°F	400°F	425°F	450°F	500°F	550°F	600°F
J U N C T I O N	90°F	3.26	4.77	6.30	7.06	7.83	9.37	10.14	10.91	12.46	14.00	15.53
	88°F	3.32	4.83	6.36	7.12	7.89	9.43	10.20	10.97	12.51	14.05	15.59
	86°F	3.37	4.88	6.41	7.17	7.94	9.49	10.26	11.03	12.57	14.11	15.65
	84°F	3.43	4.94	6.47	7.23	8.00	9.54	10.31	11.09	12.63	14.19	15.71
	82°F	3.49	5.00	6.53	7.29	8.06	9.60	10.37	11.14	12.69	14.23	15.76
	80°F	3.55	5.06	6.59	7.35	8.12	9.66	10.43	11.20	12.74	14.28	15.82
	78°F	3.60	5.11	6.64	7.40	8.17	9.72	10.49	11.26	12.80	14.34	15.86
	76°F	3.66	5.17	6.70	7.46	8.23	9.77	10.55	11.32	12.86	14.40	15.94
	75°F	3.69	5.20	6.73	7.49	8.26	9.80	10.57	11.35	12.89	14.43	15.97
	74°F	3.72	5.23	6.76	7.52	8.29	9.83	10.60	11.37	12.92	14.46	15.99
T E M P	72°F	3.78	5.29	6.82	7.58	8.35	9.89	10.66	11.43	12.97	14.51	16.05
	70°F	3.83	5.34	6.87	7.63	8.40	9.95	10.72	11.49	13.03	14.57	16.11
	68°F	3.89	5.40	6.93	7.69	8.46	10.00	10.78	11.55	13.09	14.63	16.17
	66°F	3.95	5.46	6.99	7.75	8.52	10.06	10.83	11.61	13.15	14.69	16.23
	64°F	4.01	5.52	7.05	7.81	8.58	10.12	10.89	11.66	13.20	14.74	16.28
	62°F	4.06	5.57	7.10	7.86	8.63	10.18	10.95	11.72	13.26	14.80	16.34
	60°F	4.12	5.63	7.16	7.92	8.69	10.24	11.01	11.78	13.32	14.86	16.40

MERCURY CONTACTOR

1. Shut off power at the main breaker.
2. Remove conveyor.
3. Remove control compartment covers.
4. Disconnect contactor wires and mark for reinstallation.
5. Remove screws from mounting bracket and replace contactor.
NOTE: Be sure contactor is not mounted upside down at this will cause a constant on condition.
6. Reassemble in reverse order.

GAS VALVE

1. Shut off power at main breaker.
2. Shut off the gas supply in the main line to the oven.
3. Disconnect the flexible gas hose.
4. Remove the control compartment covers.
5. Remove the manual gas shut off valve from piping.
6. Remove screws from the bulkhead plate located on rear of oven at the gas pipe.
7. Remove the section of gas pipe to gas valve.
8. Disconnect the electrical leads from the solenoid valve.
9. Loosen the gas line union located near the burner and remove the gas valve and solenoid valve assembly.
10. Finish removal of the gas piping from gas valve.
11. Replace in reverse order.
12. Check all gas fittings for leaks.
13. Adjust the gas manifold pressure on the gas valve. "Refer to the specification plate on the oven for proper rating".

SOLENOID VALVE

1. Shut off power at main breaker.
2. Shut off gas supply.
3. Remove rear control box cover.
4. Disconnect wires from solenoid valve. Mark wires for reassembly.
5. Loosen pipe union in piping assembly.
6. Remove 4 nuts from burner manifold and remove valve assembly.

7. Remove piping from solenoid valve.
 8. Reassemble in reverse order.
- NOTE:** Some piping changes may be required. See instructions supplied with replacement part.

HEATING ELEMENTS

1. Shut off power at main breaker.
2. Remove back cover.
3. Disconnect heater element wire and mark for reassembly.
4. Disconnect motor wiring and mark for reassembly.
5. Remove oven back from oven.
6. Remove fan shroud.
7. Heater element may now be unbolted and removed.
8. Check heater elements to be sure they are the proper replacement.
9. Reassemble in reverse order.

NOTE: Be sure the lead terminals are tight.

IGNITION CONTROL

1. Shut off power at main breaker.
 2. Shut of the gas supply in the main line to the oven.
 3. Remove conveyor.
 4. Remove the front control compartment cover.
- Note: After S/N 2011383 a removable drip tray is located above the ignition control.
5. Disconnect the wires from the ignition control and mark their location for reinstallation.
 6. Remove the 4 mounting screws and remove the control.
 7. Reassemble in reverse order.
 8. Turn on electrical power and gas supply, then check the system for proper operation.

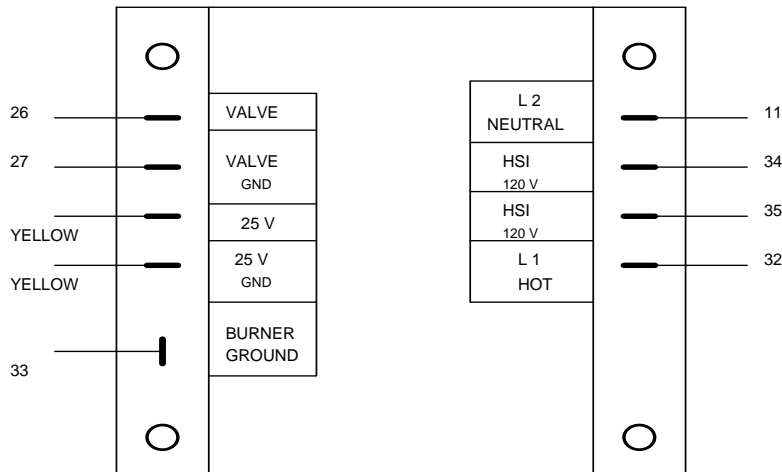

IGNITION CONTROL

TRANSFORMER, STEP DOWN 24 VAC

1. Shut off power at the main breaker.
2. Remove conveyor.
3. Remove front control compartment cover.
4. Remove wires from transformer and mark for reassembly.
5. Remove 2 mounting screws and replace transformer.
6. Reassemble in reverse order.

BURNER VENTURI

See "Hot Surface Igniter"

HOT SURFACE IGNITER

1. Shut off the electrical power at main breaker.
2. Shut off the gas supply in the main line to the oven.
3. Remove conveyor.
4. Remove rear control compartment cover.
5. Remove Conveyor Motor.
6. Remove electrical plug from the burner cap.
7. Loosen the pipe union in the gas line.
8. Remove 3 screws holding burner cap to burner tube.
9. Pull out on burner cap removing cap and burner venturi.
10. The hot surface igniter is held in place on the burner venturi by a screw, loosen screw and remove igniter.
11. Replace in reverse order.

NOTE: Care must be used when handling the hot surface igniter as they are quite fragile and may be easily broken if dropped or bumped.

ORIFICE, MAIN BURNER

1. Shut off power at main breaker.
2. Shut off gas at main line to the oven.
3. Remove conveyor.
4. Remove control compartment covers.
5. Loosen 4 nuts holding manifold to burner cap.
6. Loosen pipe union. Remove valve and manifold.
7. Remove main orifice
8. Reassemble in reverse order.

ORIFICE, BYPASS

1. Loosen flare nut and remove bypass orifice.
2. Reassemble in reverse order.

THERMOSTAT, HIGH LIMIT, OVEN CAVITY

1. Shut off power at main breaker.
2. Remove conveyor.
3. Remove control compartment covers.
4. Remove screws from bracket.
5. Remove the mounting nut from the threaded shaft.
6. Remove the capillary tube bulb from the wire holder in the oven heating chamber.
NOTE: Access to the capillary tube bulb is through the front door, after removing the conveyor and fingers.
7. Insert the new capillary tube bulb through the tube into the oven cavity and into the wire form holder
NOTE: The wire form must hold the bulb firmly. If it does not, compress the wire form slightly to increase the pressure.
8. Reassemble in reverse order.
9. Push the reset button. Test system for proper operation.

THERMOSTAT, HIGH LIMIT

1. Shut off power at main breaker.
2. Remove conveyor.
3. Remove control compartment covers.
4. Remove 2 screws from holding bracket located in upper rear of the control compartment.
5. Remove the 2 leads and remove thermostat.
NOTE: Push reset button
6. Insure that aluminum probe and teflon washer are in place (if applicable), then reassemble in reverse order.
7. Insure that thermostat is in firm contact with the aluminum probe (if applicable).

LAMP, PILOT BURNER

LENS, PILOT LAMP

1. Shut off power at main breaker.
2. Remove conveyor.
3. Remove front control compartment cover.
4. Remove terminals from pilot lamp.
5. Grasp body of the light assembly and slide to the side disengaging body from light lens.
6. Remove lens by pushing out from rear.
7. Reassemble in reverse order.

COUPLING, CONVEYOR DRIVE

FOR ALL 1100 MODELS

This coupling has a plastic or rubber sleeve connecting two metal drive ends. The metal drive end on the conveyor side is secured by a ball plunger screw. This is not a set screw and should never be over tightened.

PROCEDURE FOR ADJUSTING DRIVE COUPLING:

1. Place one metal end on conveyor shaft.
2. Install ball plunger and adjust so the spring loaded ball will drop into the dimple on the flat of the conveyor drive shaft. To test, apply pressure on metal end towards the conveyor. The ball detent should pop up out of the dimple and coupling end will slide back to conveyor frame.
3. Place other drive end on motor shaft,
4. Push conveyor frame to front side of oven conveyor opening.
5. Adjust the metal drive end on conveyor shaft so ball detent is in the dimple.
6. Lift the conveyor drive side slightly and place sleeve on conveyor side metal drive end.
7. Adjust motor side coupling drive end so sleeve is now held in place between the drive ends and tighten set screw on motor side firmly.

To remove conveyor, simply grasp the coupling sleeve and pull towards conveyor. The sleeve and drive end will slide towards the conveyor and separate from the motor drive.

GEARMOTOR, D.C., CONVEYOR

1. Shut off power at main breaker.
2. Remove conveyor.
3. Remove control compartment covers.
4. Remove metal drive end from the motor shaft.
5. Remove electrical leads from gearmotor assembly and mark for proper reassembly.
6. Remove 4 screws holding gearmotor to the side wall of control compartment.
7. To remove tach., optical encoder assembly, and coupling and encoder disc refer to the following instructions.
8. Reassemble in reverse order using care to readjust motor properly to be in line with conveyor coupling.

NOTE: If a new gearmotor is installed, the D.C. motor control board must be recalibrated.

COUPLING AND ENCODER DISC

1. Remove gearmotor assembly (See "GEARMOTOR")
2. Remove dust cover above motor.
3. Loosen both allen set screws (.050 inch allen wrench) located on coupling hub.
4. Remove 3 screws from tach. bracket, loosen the 4th.
5. Remove encoder assembly, see "OPTICAL ENCODER ASSEMBLY" in following procedure.
6. Push coupling down on motor shaft. Swivel tach. bracket aside and remove coupling.
7. To install, push coupling on to motor shaft. The encoder disc must be nearest motor.
8. Refasten tach. bracket in proper alignment.
9. Tighten the set screw on the tach. side first maintaining the .010 minimum dimension between the coupling hub and tach.
10. Pull the coupling apart (approximately 1/8",3.2mm) and fasten the motor side set screw.

11. Install the optical encoder, refer to "OPTICAL ENCODER" in this section for adjustment.

NOTE: The thin, slotted encoder disc must be handled with care so not to bend it.

12. Recheck tightness on the set screws to be sure they are tight. If available, LOC TITE (the removable kind) should be used to secure set screws.

OPTICAL ENCODER ASSEMBLY

1. Remove gearmotor assembly (see "GEARMOTOR") Above.
2. If replacing with new assembly, cut wires to remove as new wires and plug are provided. If only removing for access to coupling, see step 3.
3. Remove pins from connector with pin extractor tool, P/N 369600.
4. Loosen dust cover screws and pull dust cover away from motor.
5. Remove 2 screws from optical encoder and remove encoder.
6. Reassemble in reverse order.
7. To adjust optical encoder:
 - a. Position the encoder assembly so it does not rub the coupler hub and is square with the encoder disc. The infrared light beam will be broken by slots in the encoder disc. The encoder disc should not touch the bottom or top of the optical encoder, if it does, readjust the coupling. The digital speed readout may be observed to check proper adjustment of the optical

TACH. GENERATOR

1. Turn off power at main breaker.
 2. Remove gearmotor assembly (see "GEARMOTOR")
 3. Remove tach. cover plate and tach. leads. Mark wires for reassembly.
 4. Remove 2 slotted screws from dust cover base and remove dust cover.
 5. Loosen coupling set screw (.050 inch allen wrench).
 6. Remove tach. bracket from motor. (4 screws)
 7. Remove 4 screws from base of tach. and tach. is now free for removal.
 8. Reassemble in reverse order. Maintain spacing of .010 minimum between tach.bracket and coupler hub.
- NOTE:** If a new tach. generator is installed, the D.C. motor control board MUST BERECALIBRATED. There is no repair procedure for the tach. If defective, replace.

D. C. MOTOR CONTROL BOARD

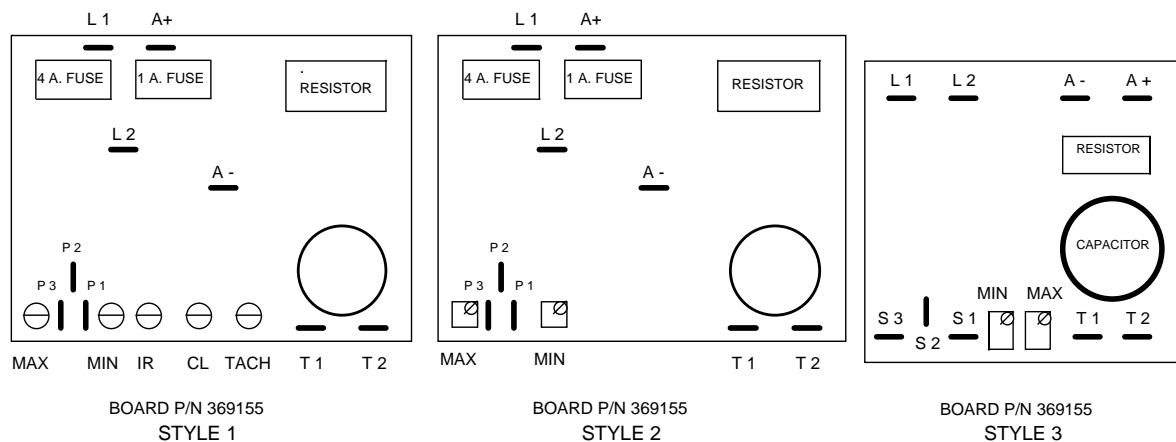

Three different styles of control boards have been used and all three are still usable. All three were supplied under the same part number.

TO REPLACE THE CONTROL BOARD:

1. Turn off power at main breaker and remove front control compartment cover.
2. Remove conveyor.
3. Remove and mark all wires from board
4. Remove control board bracket and board from unit, 3 screws.
5. Remove control board from mounting bracket. Remove 4 screws, lockwashers, and nuts.

6. Install new control board and bracket.
7. Attach wires to their proper terminals, refer to the drawings for proper terminal identification.
8. Perform calibration on the control board as specified using the calibration procedure for your style of board.
NOTE: When a control board, motor, tach. generator, or speed adjustment potentiometer is replaced, the control board must be calibrated. When calibration of control board is complete, seal the adjustment pots. (See "Control Board Adjustment")

STYLE 1 CONTROL BOARD ADJUSTMENT

NOTE: A digital meter must be used for this adjustment.

1. Voltage at L1 and L2 terminals of the control board is to be 120 VAC \pm 10%.
2. Connect a digital volt meter to terminals A+ and A-, set meter on 200 VDC scale.
3. Turn speed control pot. (on oven control panel) to its maximum speed setting.
4. Turn "MAX", "MIN", and "IR" pots counter clockwise until they stop. (DO NOT turn CL pot.)
5. Adjust "TACH" pot. so the volt meter indicates 130 VDC \pm 0.5 volts.
6. Adjust "IR" pot. to read between 1.5 and 2 VDC above tach. reading. (Example: If tach. reading would be 130.3 then adjust IR to between 131.8 VDC and 132.3 VDC.)
7. Turn speed control pot. to its minimum speed setting.
8. Adjust "MIN" pot. so the voltmeter indicates between 6 and 10 VDC.
9. Turn speed control dial to obtain a reading of 22 VDC on your meter. Observe for approx. 30 seconds to see if stable within \pm 0.5 VDC. Repeat at 35 VDC.
10. Check speed of conveyor and adjust time/temp. display if necessary.
11. Seal pots with Glyptol or nail polish.

STYLE 2 AND STYLE 3 CONTROL BOARD ADJUSTMENT

NOTE: A digital meter must be used.

1. Voltage at L1 and L2 terminals of the control board is to be 120 VAC \pm 10%.
2. Connect a Digital voltmeter to terminal T1 and T2, set the meter on DC scale.
3. Turn the speed control pot. (on oven control panel) to its maximum speed setting.
4. Adjust the "MAX" pot. so the voltmeter indicates 15.8 to 15.9 VDC.
5. Turn the speed control pot. to its minimum speed setting.
6. Adjust the "MIN" pot. so the volt meter indicates 0.7 to 0.9 VDC.
7. Reset the speed control pot. to its maximum speed setting and check if voltage is still at 15.8 to 15.9 VDC. Readjust if necessary.
8. Reset the speed control pot. to its minimum speed setting and check if voltage is still at 0.7 to 0.9 VDC. Readjust if necessary.
9. If readjustment of either the "MAX" or "MIN" pot. was necessary, the opposite must always be checked until both "MIN" and "MAX" are in proper adjustment.
10. Measure the speed of the conveyor and adjust the time/temp. display if necessary.
11. Seal pots with Glyptol or nail polish.

NOTE: Occasionally a new board (Style 2 and 3 only) is so far out of adjustment that you will be unable to adjust to the correct voltage. To correct, turn both the "MAX" and "MIN" pots 10 turns in either direction and then 5 turns in opposite direction. This will center the pots and allow them to be calibrated. If after this procedure, the board will not adjust, it is probably defective.

REVERSAL OF CONVEYOR BELT - D.C. Motor

All ovens leaving our plant are wired to operate conveyors from left to right. To reverse conveyor direction, use the following procedure.

1. Turn off power and remove conveyor.
2. Remove front control compartment cover.
3. Refer to control board drawing to identify terminal connections.
4. Reverse wires fastened to terminals A+ and A-.
5. Reverse wires fastened to terminals T1 and T2.

Both set of leads must be reversed or oven will run at maximum speed with no speed adjustment possible.

POTENTIOMETER, CONVEYOR SPEED CONTROL

1. Turn off power.
2. Remove conveyor.

3. Remove front control compartment cover.
4. Remove adjustment knob. Two allen set screws.
5. Remove exterior friction shaft retainer from pot shaft. Turn counter-clockwise to loosen.
6. Remove pot shaft from hole and disconnect leads from motor control board.
7. Assemble in reverse order.
8. If a new pot. is installed, the motor control board must be calibrated.

MINI BREAKER 0.2 AMP

1. Shut off power at main breaker.
2. Remove conveyor.
3. Remove control box covers.
4. Remove knurled mounting ring and disconnect wiring.
5. Reassemble in reverse order.
6. Push button to set.

BEARING, CONVEYOR

1. Remove conveyor from oven and place on a flat work surface.
2. Remove connecting links from conveyor belting. See Installation and Operating Instructions manual.
3. Move drive shaft or idle shaft toward end of conveyor, and shaft with bearings will now slip out of holding bracket.
4. Replace bearing and reassemble.

TRANSFORMER, TIME/TEMP. DISPLAY

1. Shut off power at the main breaker.
2. Remove conveyor.
3. Remove front control compartment cover.
4. Remove transformer wires and mark for replacement.
5. Remove the 2 mounting screws and replace transformer.
6. Reassemble in reverse order.

TIME/TEMP. DISPLAY

1. Shut off power at main breaker.
2. Remove conveyor.
3. Remove front control box cover.
4. Mark all leads for proper reinstallation and then remove wires from all terminals at rear of the display.
5. Remove 2 screws from top of Time/Temp. case holding the case to the front panel.
NOTE: On some of the more recent Model 1100 units, the time/temp. display may now be removed. If it is not free, continue.
6. Remove 3 screws from the front panel, lift up the front panel and remove 2 screws from the bottom of the display case. Display should now be free to remove.
7. Replace in reverse order.
NOTE: BEFORE TURNING ON POWER, SET THE DIP SWITCHES TO THE PROPER SETTING.

DIP SWITCH SETTING CHART:

To identify the module, measure the width of the case.
 Type I is 5 1/8 inches wide x 4 1/2 inches deep
 Type II is 5 5/8 inches wide x 4 1/2 inches deep
 Type I & II have a 6 position dip switch module
 Type III has a 10 position dip switch module
 Type IV is 5 5/8 inches wide x 3 1/4 inches deep
 Type IV has adjustment pots. in the center of the board

*THESE SWITCHES ARE FOR HERTZ SETTINGS - OFF=60HZ or ON=50HZ

**THESE SWITCHES ARE FOR TEMPERATURE SETTINGS - OFF=°F or ON=°

MODEL 1100 SERIES OVENS

	1	2	3	4	5	6	7	8	9	10
Type 1	Off	* Off	On	On	** Off	Off				
Type II	Off	*	**	On	Off	On				
Type III (Baldor)	Off	*	**	Off	On	On	On	Off	On	On
Type III (Stepper)	Off	*	**	On	On	Off	Off	On	Off	On
Type IV (Baldor)	Off	Off	**	Off	On	On	On	Off	On	On
Type IV (Stepper)	Off	Off	**	On	On	Off	Off	On	Off	On

Stepper Motor - Conveyor Speed 23 Seconds to 30 Minutes

Type III	Off	* Off	** Off	On	On	Off	On	Off	On	On
Type IV	Off	Off	** Off	On	On	Off	On	Off	On	On

TIME TEMP DISPLAY FOR D.C. DRIVE

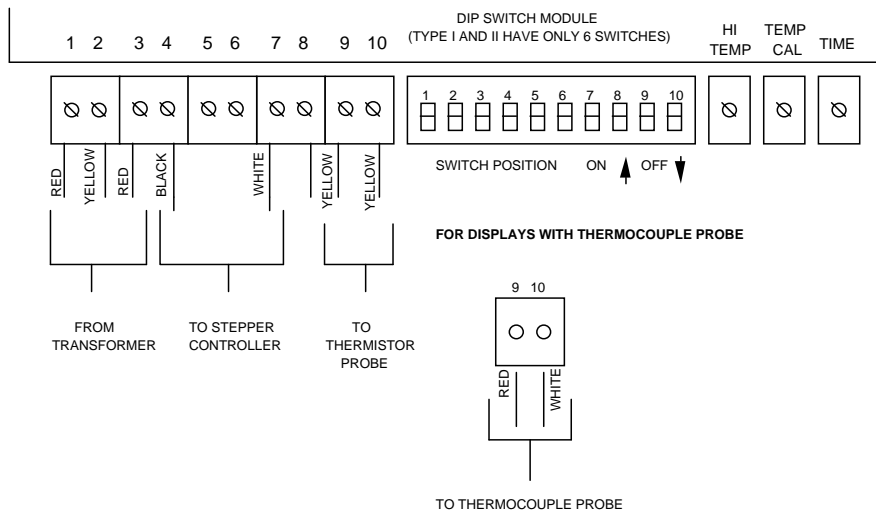

TEMPERATURE CALIBRATION

1. Set dip switches per chart on page 43.
2. Place a thermocouple from your test pyrometer through a hole in the center of the top finger. Tip of pyrometer must not touch metal!
3. Set oven at 500°F (260°C) and allow to preheat for 30 minutes.
4. Adjust temperature calibration pot. so display agrees with your test meter.
5. Seal pot. with Glyptol or nail polish.
6. If display will not adjust properly, check your pyrometer for accuracy and if necessary, refer to troubleshooting section.

If temperature is still inaccurate after above calibration and troubleshooting, use the following to check the High Temp. Pot. normally the High Temp. Pot. does not require adjustment. Occasionally the pot. is accidentally moved or needs adjustment. Refer to the following drawing showing proper adjustment of the High Temp. Pot.

FOR DISPLAYS WITH THERMISTOR PROBE ONLY

BOTTOM OF TIME TEMP DISPLAY

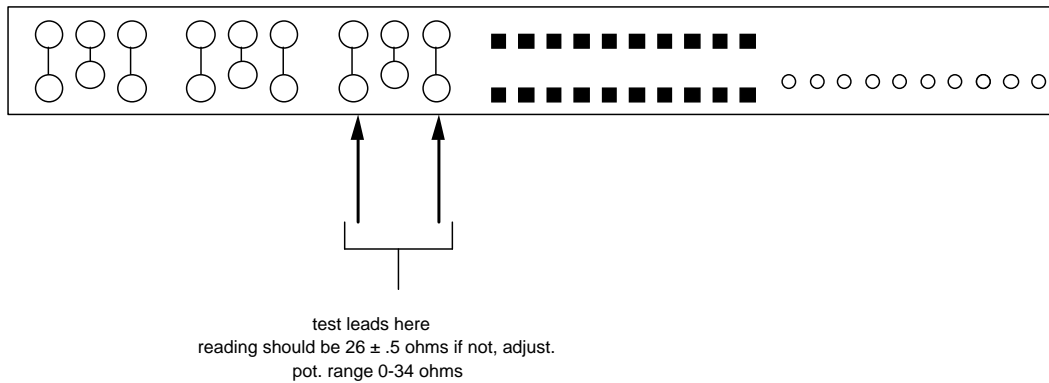

TIME CALIBRATION

1. Be sure dip switch settings are proper.
2. Turn power on.
3. Turn conveyor on.
4. Place an object on the conveyor belt and time with a stopwatch, the elapsed time for the object to travel through the oven (leading edge in to leading edge out).
5. Push in and hold the set button. (Discontinued on newer models)
6. Adjust time pot. (rear of display) so display agrees with your stop watch time.
7. Seal pot. with Glyptol or nail polish.

THERMISTOR PROBE REPLACEMENT

1. Shut off power at the main breaker.
 2. Remove conveyor and fingers from oven.
 3. Remove control compartment covers.
 4. Disconnect the 2 yellow thermistor leads from terminals 9 and 10 on the rear of the time/temp. display.
 5. Remove the sensing bulb of the thermistor probe from its wire form holder located at right inside rear of the oven.
 6. Install in reverse order.
- NOTE:** Be sure that the spring holder is holding the sensor bulb firmly. If the sensor is not held firmly, compress the wire form slightly to increase pressure.

To test the thermistor probe, refer to the following chart and instructions:

	OVEN TEMPERATURE							
	300°F	325°F	350°F	400°F	425°F	450°F	500°F	550°F
OHMS	182	138	102	62	48	38	24	16

1. Place test pyrometer thermocouple and preheat oven as specified under temperature calibration on page 43.
 2. Disconnect the thermistor probe from terminals 9 and 10 and measure the resistance across the 2 yellow leads.
 3. Refer to the above chart to determine if probe is producing the proper resistance.
- EXAMPLE:** The probe resistance at 500°F(260°C) should be 24 ohms.

SWITCH, DISPLAY, SET

1. Shut off power at main breaker.
2. Remove conveyor.
3. Remove front control compartment cover.
4. Disconnect wires from time/temp. display terminals 5 and 6.
5. Pull off black operating knob and remove hex mounting nut.
6. Reassemble in reverse order.

PROCEDURE FOR USE OF TIME/TEMP SIMULATOR

NOTE: For displays with Thermocouple, simulator will not work.

This is a test device used to check the Time/Temp. Display

1. Procedure for use:
Check incoming power to display at following terminals.
 - a) Terminal 1 to 3 should have approximately 12.5 to 15 VAC.
 - b) Terminal 2 to 1 should be 1/2 of the reading from 1 to 3.
 - c) Terminal 2 to 3 should also be 1/2 of the reading from 1 to 3.
2. Identify Display type:
 - a) Type 1 has 6 dip switches and display case is 5 1/8" wide (12.8cm).
 - b) Type 2 has 6 dip switches and display case is 5 5/8" wide (14 cm).
 - c) Type 3 has 10 dip switches.
3. Set Dip Switches as follows:

	1	2	3	4	5	6	7	8	9	10
TYPE 1	OFF	OFF	OFF	ON	OFF	OFF				
TYPE 2	OFF	OFF	OFF	OFF	OFF	OFF				
TYPE 3	OFF	OFF	OFF	OFF	OFF	OFF	OFF	ON	OFF	ON

4. WITH POWER OFF: Remove all leads from T/T display except power input on 1,2 and 3. Install simulator to terminals 4, 7, 9, 10.
NOTE: When on 50 Hz power dip switch number 2 must be on.
5. **WITH POWER ON:** Turn time and temperature adjustment pot. fully counter clockwise. Display should read (wait 15 seconds after turning):

	SPEED	TEMPERATURE
TYPE 1	9:30 ± 10 SEC	475° ± 10°F
TYPE 2	9:20 ± 10 SEC.	HHH
TYPE 3	9:35 ± 10 SEC.	635° ± 10°F

6. Turn time and temperature pot. fully clockwise.
Display should read (wait 15 seconds after turning):

	SPEED	TEMPERATURE
TYPE 1	10:20 ± 10 SEC	615° ± 10°F
TYPE 2	10:10 ± 10 SEC	475° ± 10°F
TYPE 3	. 10:20 ± 10 SEC	475° ± 10°F

7. For performance test, turn time pot. to 10:00 and temp. adjustment pot. To 540° ± 10°F.
 - a) Time reading on display of 10:00 should not fluctuate more than ± 5 seconds.
 - b) Temperature on display reading should not fluctuate.

SWITCH, ON/OFF

1. Shut off power at main breaker.
2. Remove conveyor.
3. Remove front control compartment cover.
4. Remove wires from switch and mark for reassembly.
5. Depress spring clips on the side of switch and push out.
6. Reinstall in reverse order.

TRANSFORMER, STEP DOWN/120 VAC

1. Shut off power at main breaker.
2. Remove Conveyor.
3. Remove control compartment covers.
4. Remove wires from transformer and mark for reassembly.
5. Remove 4 mounting screws from transformer base and replace.
6. Reassemble in reverse order.

FUSEHOLDER

1. Shut off power at main breaker.
2. Remove conveyor.
3. Remove control compartment covers.
4. Remove wires and mark for reassembly.
5. Remove fuseholder.
6. Reassemble in reverse order.

POWER CORD

1. Shut off power at main breaker.
2. Remove conveyor.
3. Remove control compartment covers.
4. Unfasten and mark for reassembly power cord wires.
5. Remove locknut from strain relief and pull cord from oven.
6. Reassemble in reverse order.

STEPPER CONTROL-REPLACEMENT-ADJUSTMENT

Removal and Installation

1. Remove conveyor.
2. Remove control box cover - front.
3. Remove three (3) screws from control assembly.
4. Disconnect wiring (push on connectors) from control board.
NOTE: Proper location of connectors for reinstallation.
5. Reassemble in reverse order and check system operation.
6. Recalibrate conveyor control board.

WARNING: THIS CONTROL MUST NOT BE OPERATED WITH HEAT SINK DISCONNECTED OR BURNOUT WILL OCCUR IN SECONDS.

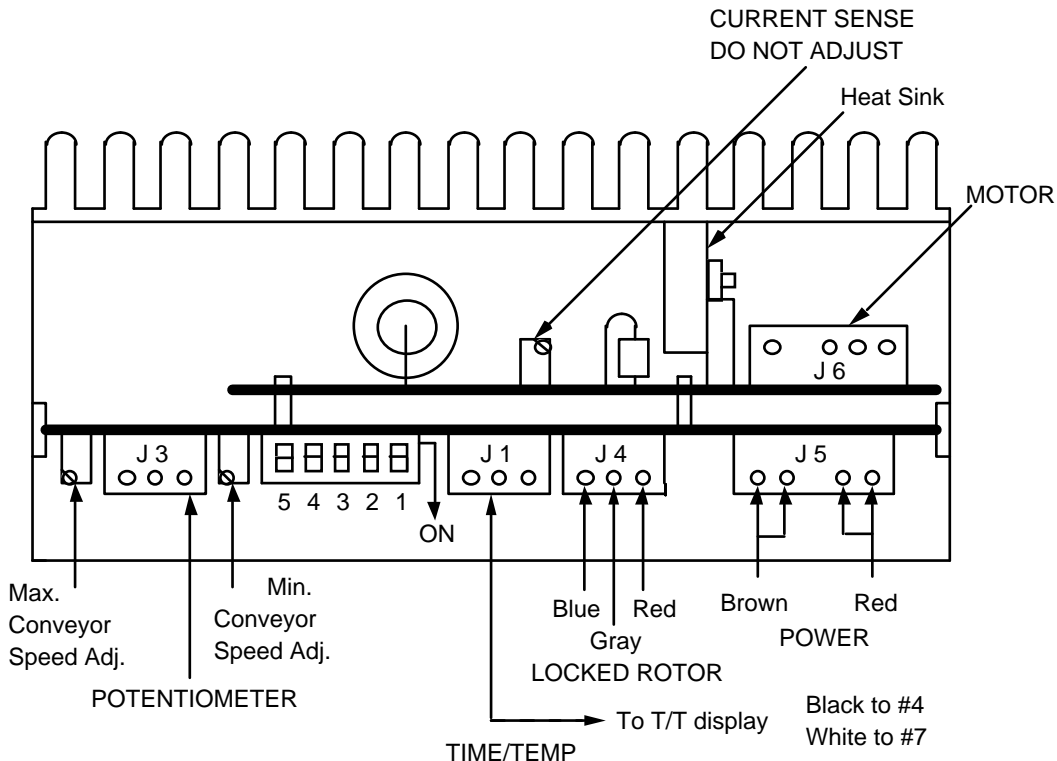

1. With power off, the five (5) dip switches located on the conveyor control (see drawing above) should be set as below.

DIP SWITCHES FOR 50 SEC. TO 30 MIN. TIMES

CONTROL	1	2	3	4	5
SWITCH POSITION	OFF	OFF	ON	OFF	OFF

DIP SWITCHES FOR 23 SEC. TO 30 MIN. TIMES

CONTROL	1	2	3	4	5
SWITCH POSITION	OFF	ON	OFF	OFF	OFF

1. With power off, the ten (10) dip switches located on rear of Time/Temp Display (see drawing on page 43) should be set as below.

NOTE: For time/temp displays using a thermistor (2 yellow wires on Terminals 9 & 10), set the dip switches as follows:

FOR 50 SEC TO 30 MIN CONVEYOR TIMES

DISPLAY	1	2	3	4	5	6	7	8	9	10
SWITCH POSITION	OFF	*	*	ON	ON	OFF	OFF	ON	OFF	ON

For time/temp displays using a thermocouple (red wire on #9 and white wire on #10), set the dip switches as follows:

DISPLAY	1	2	3	4	5	6	7	8	9	10
SWITCH POSITION	OFF	OFF	*	ON	OFF	OFF	ON	ON	OFF	ON

- * Off for °F
- * On for °C

FOR 23 SEC. TO 30 MIN. CONVEYOR TIMES

NOTE: For time/temp displays using a thermistor (2 yellow wires on Terminals 9 & 10), set the dip switches as follows:

DISPLAY	1	2	3	4	5	6	7	8	9	10
SWITCH POSITION	OFF	*	*	ON	ON	OFF	ON	OFF	ON	ON

- *SWITCH 2 - OFF FOR 60HZ, ON FOR 50HZ
- *SWITCH 3 - OFF FOR °F, ON FOR °C

For time/temp displays using a thermocouple (red wire on #9 and white wire on #10), set the dip switches as follows:

DISPLAY	1	2	3	4	5	6	7	8	9	10
SWITCH POSITION	OFF	OFF	*	ON	OFF	OFF	ON	ON	OFF	ON

- * Off for °F
- * On for °C

1. With conveyor running, set conveyor speed control so Time/Temp. Display indicates 5:00 minutes. Place a pan on the conveyor, measure (STOPWATCH) the time (SPEED OF PAN) of the leading edge in to leading edge out of oven. Turn the time adjustment pot. on the rear of the Time/Temp. Display so display agrees with time measured by the stop watch.
 2. Turn conveyor speed control fully counterclockwise and adjust the stepper control maximum speed pot(refer to drawing Pg. D-19) so the display indicates 50 seconds.
 3. Turn conveyor speed control fully clockwise and adjust the stepper control minimum speed pot so the display indicates 30 minutes.
- NOTE:** Repeat 4 and 5 to be sure settings are accurate.
4. Turn power off and set #1 dip switch to its (ON/OFF) other position and verify that the conveyor reverses direction when power is applied. Set conveyor travel direction as customer requests.

CAUTION: ALWAYS REMOVE POWER BEFORE CHANGING CONVEYOR DIRECTION.

TO REVERSE CONVEYOR DIRECTION ON STEPPER DRIVE SYSTEM

1. Shut off power at main breaker.
2. Remove conveyor.
3. Remove front control box cover.
4. Change position of dip switch #1 on stepper control board as described on page 46.
5. Reassemble in reverse order.

TRANSFORMER - STEPPER MOTOR CONTROL

1. Shut off power at main breaker.
2. Remove conveyor.
3. Remove front cover.
4. Disconnect transformer wire harness.
5. Remove two (2) mounting screws.
6. Reassemble in reverse order.

HALL EFFECT SENSOR - REPLACEMENT

Remove two (2) mounting screws and remove sensor from conveyor motor. Reinstall in reverse order.

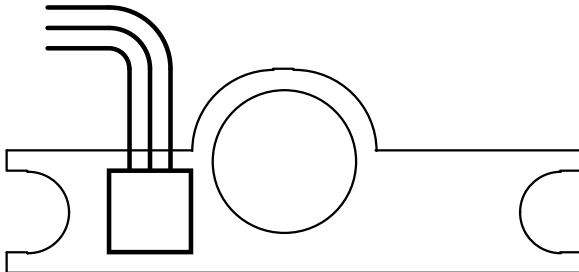

TYPE OF GAS	INCHES of WATER COLUMN	CENTIMETERS of WATER COLUMN	kPa	Mbar
NATURAL GAS	3.5" WC	8.9 cm WC	.87kPa	8.70Mbar
L..P. GAS	10"WC	25.4 cm WC	2.48kPa	24.8Mbar
CITY/TOWN GAS	1.4"WC	3.56 cm WC	.35kPa	3.5Mbar

AIR PRESSURE SWITCH, BURNER OR OVEN CAVITY

TO REPLACE AIR SWITCH:

1. Shut off power at main breaker.
2. Remove conveyor.
3. Remove rear control compartment cover.
4. Remove cover of air switch exposing adjustment screw.
5. Disconnect and mark wires for proper reassembly.
6. Remove air tube and remove switch from hanger.
7. Reinstall in reverse order, making sure wires are properly attached and air tube is properly attached, unblocked and aligned properly to avoid crimping.

TO CALIBRATE AIR SWITCH:

1. If switch will not activate when blower pressure is supplied, turn adjustment screw counter clockwise (-).
2. If switch will not deactivate when blower pressure is eliminated, turn adjustment clockwise (+).

SPARK GENERATOR

1. Turn off power.
2. Remove conveyor.
3. Remove control compartment covers.
4. Disconnect 2 power leads to ignition control. (Located in bottom front of rear control compartment).
5. Disconnect high voltage cable.
6. Remove 2 screws and lift out generator.
7. Replace in reverse order.

IGNITER SENSOR PROBE

1. See page 38 to remove "**hot surface ignitor**".
2. Unfasten screws and remove probe.
3. Disconnect wires and replace probe in reverse order.

IGNITION CONTROL

1. Shut off power at main breaker.
2. Remove control compartment covers.
3. For Honeywell Ignition Control, loosen 2 screws and remove control from base. For Landis & Gyr Ignition Control, depress 2 clips and remove control from base.
4. If replacing the control and base, remove the control first and then 2 screws holding the base. Mark wires prior to removal.
5. Reassemble in reverse order. Be sure base is correctly mounted or reset will not align with cover hole.

MOTOR, BURNER BLOWER

1. Shut off power at main breaker.
2. Remove conveyor.
3. Remove control compartment covers.
4. Remove conveyor gear motor.
5. Loosen 4 burner nuts holding burner flange to oven wall.
6. Unplug burner blower motor. This plug has built in locking clips on 2 sides of the plug. Push in to release.
7. Loosen 3 screws holding the blower air horn to burner.
8. Remove top control compartment brace.
9. Spring back side of control box out slightly, push burner to side, and you should now be able to pull the right side of the motor to the front, which should free the air horn from the burner. In some extreme cases the cooling fan may have to be removed.
10. Assemble in reverse order.

BURNER ALARM - REPLACEMENT

1. Remove control compartment covers.
2. Remove two (2) wires from alarm, note wire numbers and location.
3. Remove retainer cover from alarm and remove assembly from mounting bracket.
4. Reassemble in reverse order and check.

PARTS / GENERAL –1100 SERIES

LETTER	P/N	DESCRIPTION
A	369390	4" Caster w/ Mounting Plate
B	369502	Bottom Finger Cover
C		Columnating Plate, See Install, Operations Manual
D		Bottom Finger Housing
	369505	S/N 2018676 & Below
	370010	S/N 2018677 & Above
E	369504	Top Finger Housing
F		Columnating Plate, See Install, Operations Manual
G	369503	Top Finger Cover
H	369669	Front Panel Label (with set button)
	369907	Front Panel Label (without set button)
J	369511	Oven Top
K	369659	Conveyor Hole Cover
L	369228	Conveyor Hole Cover
M	369227	Catch Spring
N	369588	Ball Stud
	369693	Spacer for Ball Stud
O	371066	Baffle, Inlet/Outlet
P	369211	Thumb Screw
Q	370118	Cross Support
R	369919	Stand Side
S	369231	4" Caster w/ Threaded Stem
T	369232	Adjustable Leg

BLOW UP / GENERAL – 1100 SERIES

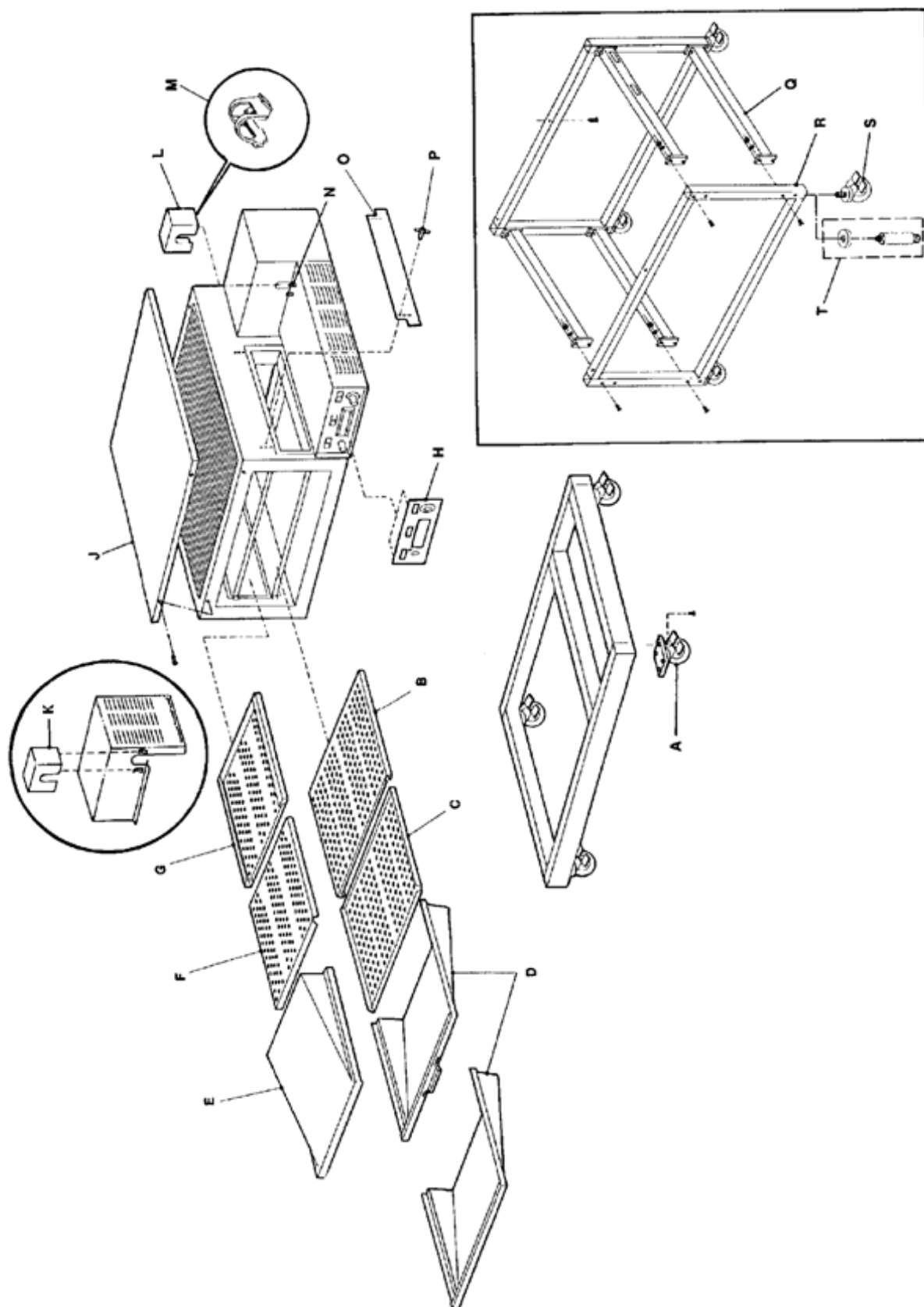

**PARTS / CONTROL COMPARTMENT FRONT 1100 - 1106, 1130 - 1136, 1150,1151,
1160 – 1163**

LETTER	P/N	DESCRIPTION
A	369173	Transformer,12.6 VAC
B	369536	Cordset, Cooling Fan
C	369124	Cooling Fan
D	350224	Lens, Yellow
	350225	Lens, Red
E	369522	Knob & Dial, Thermostat
F	369669	Front Panel Label w/Set Button Except 1150
	369907	Front Panel Label w/o Set Button Except 1150
G	369248	Knob, Speed Control
H	369247	Shaft Lock
I	370046	Button Only
J	369260	Switch, On/Off
K	369167	Switch, Display, Set
L	369680	Front Cover Assembly
M	369152	Potentiometer, Conveyor, All models prior to S/N 2011383 and Models 1160 thru 1163 prior to S/N 2011978
	369391	Potentiometer, Conveyor S/N 2011383 & Up. 1160-1163 S/N 2011978 & Up
N	369172	Display, Time/Temp
O	369128	Lamp, Pilot
P	369520	Potentiometer, Temperature
Q	369728	Temperature Control
R	369155	Conveyor Control, All Models prior to S/N 2011383 Except Model 1160-1163 prior to S/N 2011978
S	369240	High Hat (used with 369155)
T	369509	Relay Cooling Fan, Not Used On 1100-1106
U	369193	Thermistor Probe, Yellow Leads
V	369131	Thermocouple Probe, 1 Red & 1 White Lead
W	369025	Air Pressure Switch
X	369189	Terminal Block
Y	369508	Time Delay , 20 Minute Not Used On Models 1100-1106
Z	369507	Thermostat, Cooling Fan Not Used On Models 1100-1106
AA	369640	Stepper Control, Models 1130 thru 1136, 1150,1151 S/N 2011383 and Up. Models 1160thru 1163 S/N 2011978 and Up
BB	369685	Drain Assembly
CC	369605	Transformer, Stepper Controller

**BLOW UP / CONTROL COMPARTMENT FRONT 1100 – 1106,1130 – 1136, 1150,1151,
1160 – 1163**

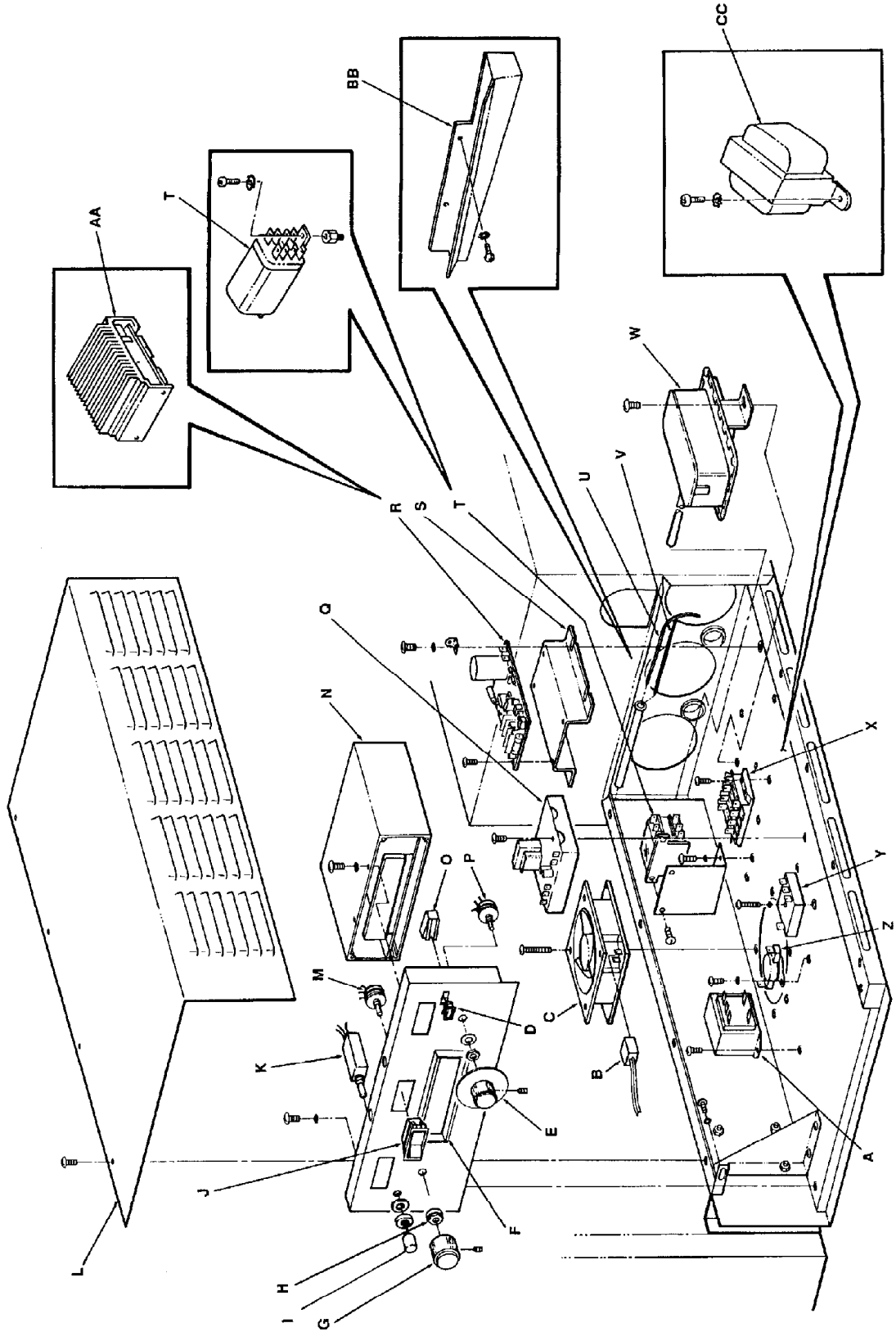

PARTS / CONTROL COMPARTMENT FRONT 1116,1117

LETTER	P/N	DESCRIPTION
A	369173	Transformer, 12.6 VAC
B	369536	Cordset, Cooling Fan
C	369124	Cooling Fan
D	350225	Lens, Red
E	369522	Knob & Dial, Thermostat
F	369669	Front Panel Label Ovens w/ Set Button
	369907	Front Panel Label Ovens w/o Set Button
G	369248	Knob, Speed Control
H	369247	Shaft Lock
I	370046	Button Only
J	369260	Switch, On/Off
K	*369167	Switch, Display, Set
L	*369152	Potentiometer, Conveyor
	**369391	Potentiometer, Conveyor
M	369680	Front Cover Assembly
N	369104	Lamp, Pilot, 24 VAC
O	369520	Potentiometer, Temperature
P	369172	Display, Time/Temp
Q	369728	Temperature Control Resistor)
Not shown	370136	Assembly (2K ohms
R	*369155	Control, Conveyor
S	*369240	High Hat
T	369193	Thermistor Probe, Yellow Leads
U	369131	Thermocouple Probe, 1 Red & 1 White Lead
V	369532	Ignition Control
W	369531	Transformer, 24 VAC
X	369189	Terminal Block
Y	357067	Thermostat, Oven Cavity, High Limit
Z	369523	Relay, Motor
AA	369508	Time Delay, 20 Minute
BB	369507	Thermostat, Cooling Fan
CC	**369640	Control, Stepper
DD	**369685	Drain Assembly
EE	**369605	Transformer, Stepper Control

* Used On S/N 2000200 Thru 2011383

** Used On S/N 2011383 And Above

BLOW UP / CONTROL COMPARTMENT FRONT 1116, 1117

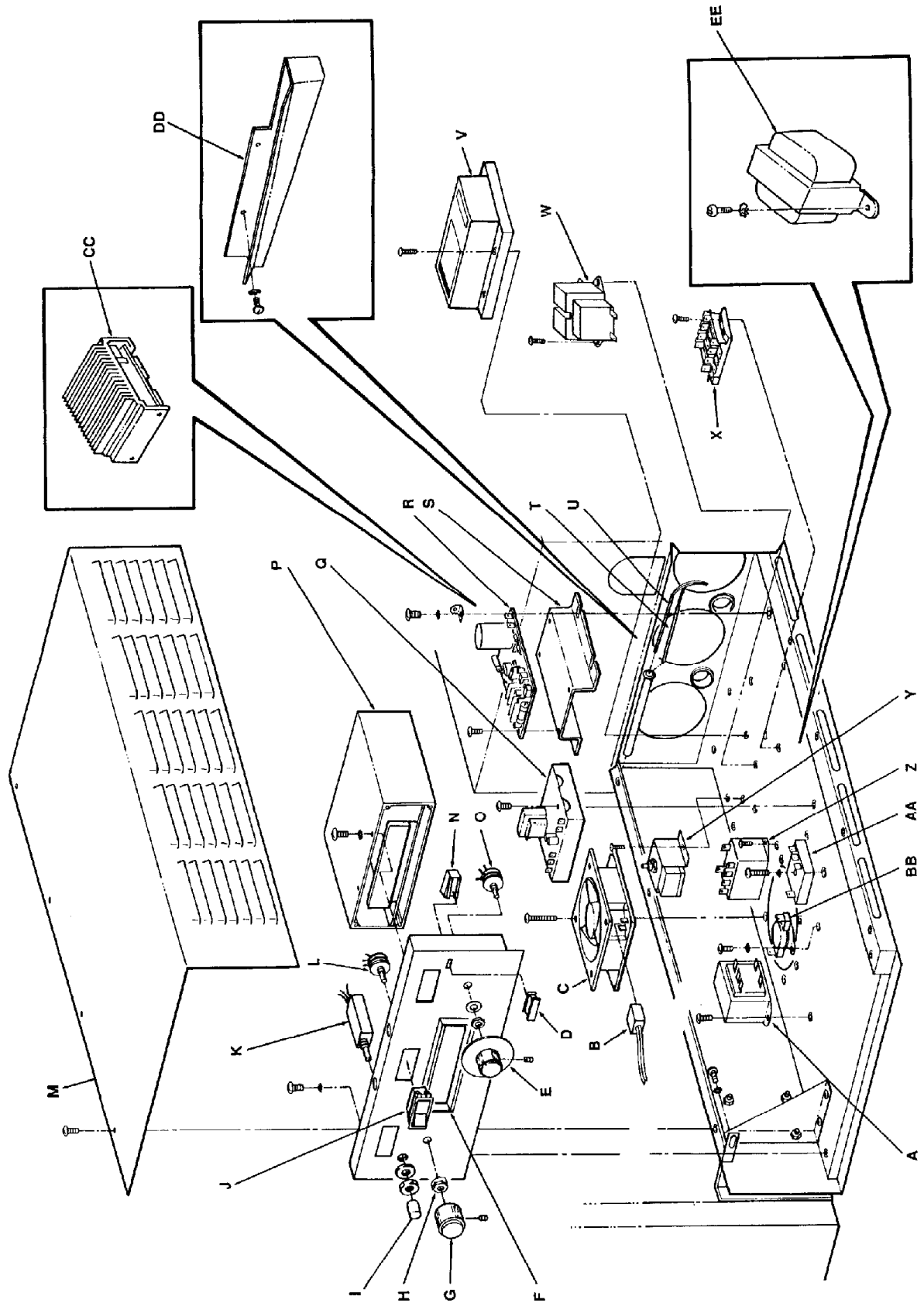

**PARTS / CONTROL COMPARTMENT REAR 1100 – 1106, 1130 – 1136, 1150,1151, S/N
2011373 & BELOW, 1160 – 1163 S/N 2011978 & BELOW**

LETTER	P/N	DESCRIPTION
A	369628	Set Screw
B	369190	Drive Coupling, Complete
C	369512	Rubber Sleeve
D	369269	`Ball Plunger
E		Gear Motor Assembly. (Refer to Page 67 for Exploded View)
F	369137	Circuit Breaker, 0.2 Amp
G	369192	Capacitor, 7.5 MFD
H	369200	Relay
I	369185	Terminal Block For 1 Phase Models (3 Required)
	369187	For 3 Phase Models (4 Required)
J	369186	Terminal Block End For 1 Phase Models
	369188	For 3 Phase Models
K	369120	Contactors For 1 Phase Models (2 Pole)
	369178	For 3 Phase Models (3 Pole)
L	354258	Transformer, Control
	354257	Transformer, Control Model 1151 Only
M	369506	Thermostat, High Limit For Models 1130,1131,1132,1133,1134,1135,1136, 1151,1160,1161,1162,1163
	369127	For Models 1100,1101,1102,1103,1104,1105,1106
N	369832	Back Cover
O	369583	Thermostat High-Limit For Model 1150
P	369772	Terminal Block
Q	370062	Electrical Box
R	370063	Cover
S	Fuses	See Chart On Page 70
T	Fuse Holders	See Chart On Page 70
U	369007	Thermostat, Cool Down For Models 1100, 1101, 1102, 1103, 1104, 1105, 1106

BLOW UP / CONTROL COMPARTMENT REAR 1100 – 1106, 1130 – 1136, 1150,1151, S/N 2011373 & BELOW, 1160 – 1163 S/N 2011978 & BELOW

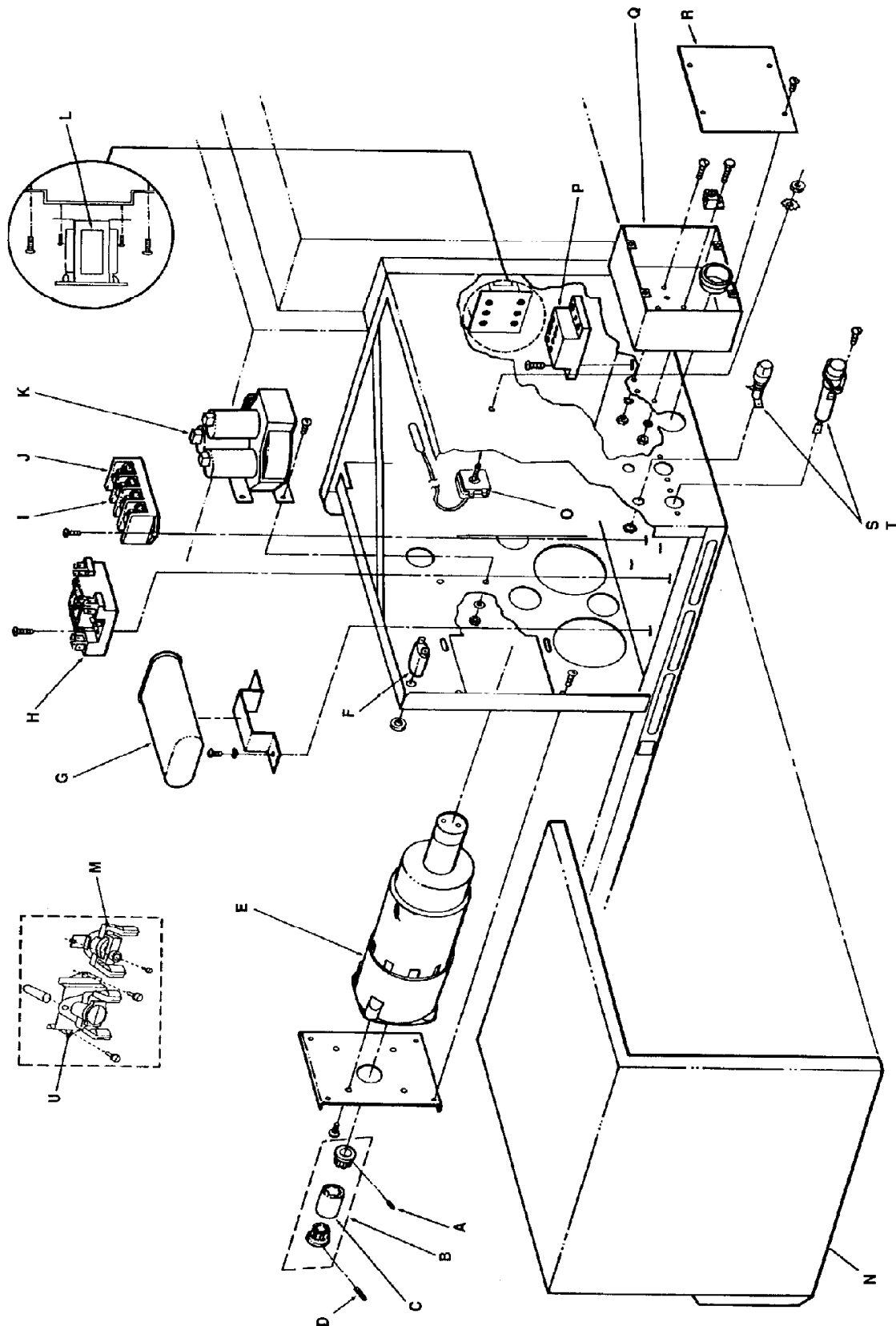

PARTS / CONTROL COMPARTMENT REAR 1130 - 1136, 1150, 1151, S/N2011383 AND ABOVE, 1160 – 1163 S/N 2011978 AND ABOVE

LETTER	P/N	DESCRIPTION
A		Terminal Block End
	369186	For 1 Phase Models
	369188	For 3 Phase Models
B		Terminal Block
	369185	1 Phase Models (3 Required)
	369187	3 Phase Models (4 Required)
C		Contactors
	369120	1 Phase (2 Pole)
	369178	3 Phase (3 Pole)
D	354258	Transformer, For Models 1134,1135,1136,1150
	354257	Transformer, For Model 1151 Only
E	369124	Cooling Fan
F	369331	Finger Guard
G	370062	Electrical Box
H	370063	Cover
I	Fuses	See Chart On Page 70
J	Fuse Holders	See Chart On Page 70
K	369200	Relay
L	369603	Conveyor Motor Assy. See Page 67 for Breakdown
M	369268	Set Screw
N	369664	Sleeve only, Conveyor Drive Coupling
O	369269	Ball Plunger
P	369611	Coupling, Conveyor Drive, Complete
Q	357067	Thermostat, Hi-Limit, All Models except 1150
	369583	Thermostat, Hi-Limit, Model 1150 only
R	369192	Capacitor, 7.5 MFD
S	353014	Ground Lug
T	369682	Back Cover Assembly

BLOW UP / CONTROL COMPARTMENT REAR 1130 - 1136, 1150, 1151, S/N2011383 AND ABOVE, 1160 - 1163 S/N 2011978 AND ABOVE

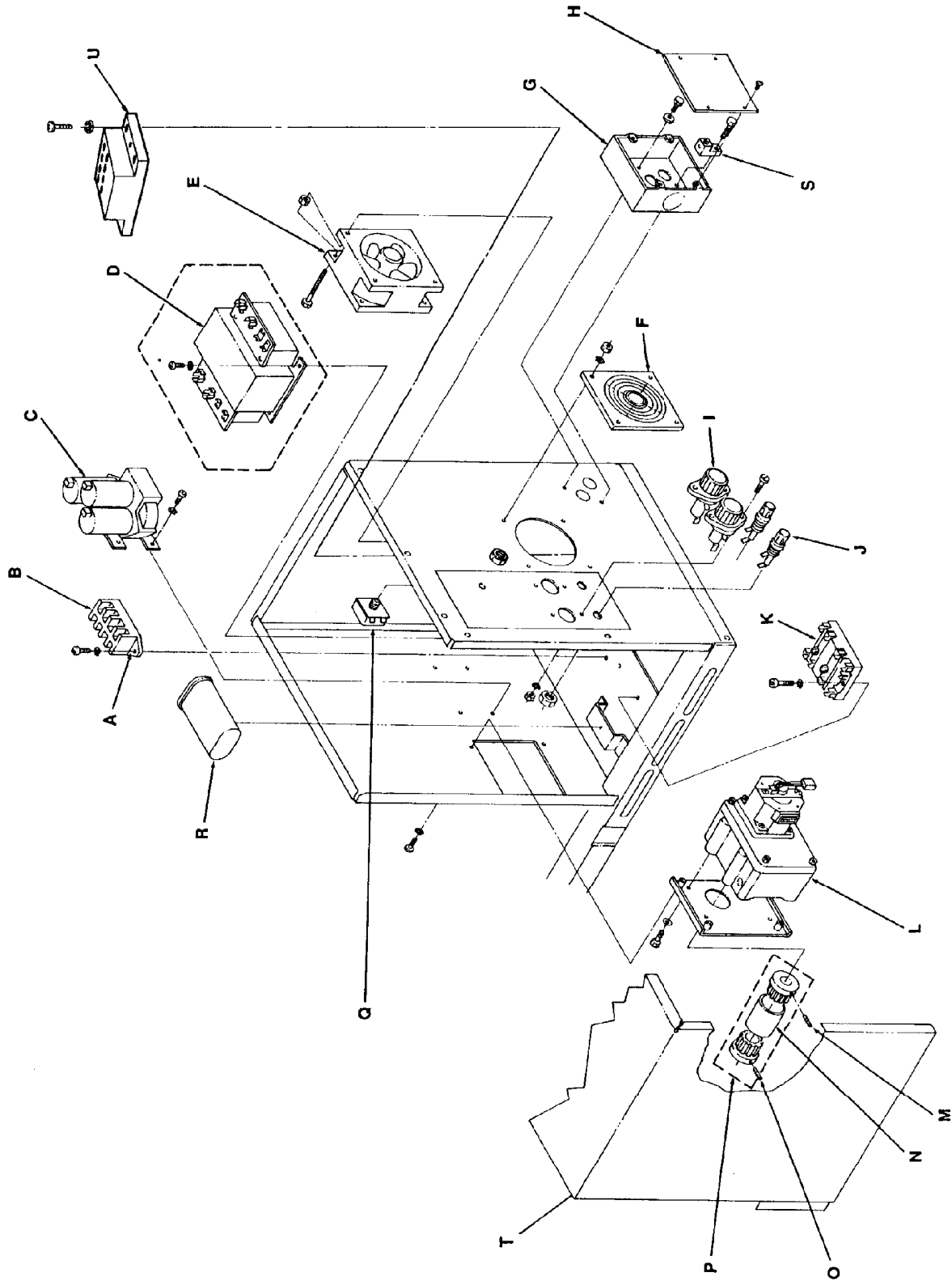

PARTS / CONTROL COMPARTMENT REAR 1116, 1117, S/N 2000200 TO 2011383

LETTER	P/N	DESCRIPTION
A		See Gear Motor Assembly on Page 67.
B	369192	Capacitor
C	369559	90 Degree Connector
D		Bypass Tube Assembly
	369561	Model 1116 (includes 369559 and 369556)
	369562	Model 1117 (includes 369559 and 369557)
E	369398	Solenoid Valve
G	370143	Back Cover Assembly
H	369567	Manifold Assembly, Burner
I	369552	Hot Surface Igniter
J	369556	Orifice, Main Burner – Natural
	369524	Orifice, Main Burner – LP
K	369568	Venturi Tube, Natural
	369938	Venturi Tube, LP
L	369556	Bypass Orifice – Natural
	369557	Bypass Orifice - LP
M	369529	Model 1116 using Honeywell Gas Valve
	369263	Johnson Gas Valve Nat/LP
N	369401	Air Shutter Assembly
O	369366	Burner Blower
P	369533	Thermostat, Control Box High Limit
Q	369124	Cooling Fan
	369535	Cooling Fan Cordset
R	353014	Ground Lug
S	369331	Finger Guard
T	369013	Fuse, 3 Amp
U	369012	Fuse Holder
V	369166	Fuse, 10 Amp
W	369129	Fuse Holder
X	369538	Strain Relief
Y	369537	Power Cord
Z	369137	Mini Breaker 0.2 Amp
AA	369190	Conveyor Coupling Complete
BB	369512	Sleeve Only, Coupling
CC	369269	Ball Plunger
DD	369268	Set Screw

BLOW UP / CONTROL COMPARTMENT REAR 1116, 1117, S/N 2000200 TO 2011383

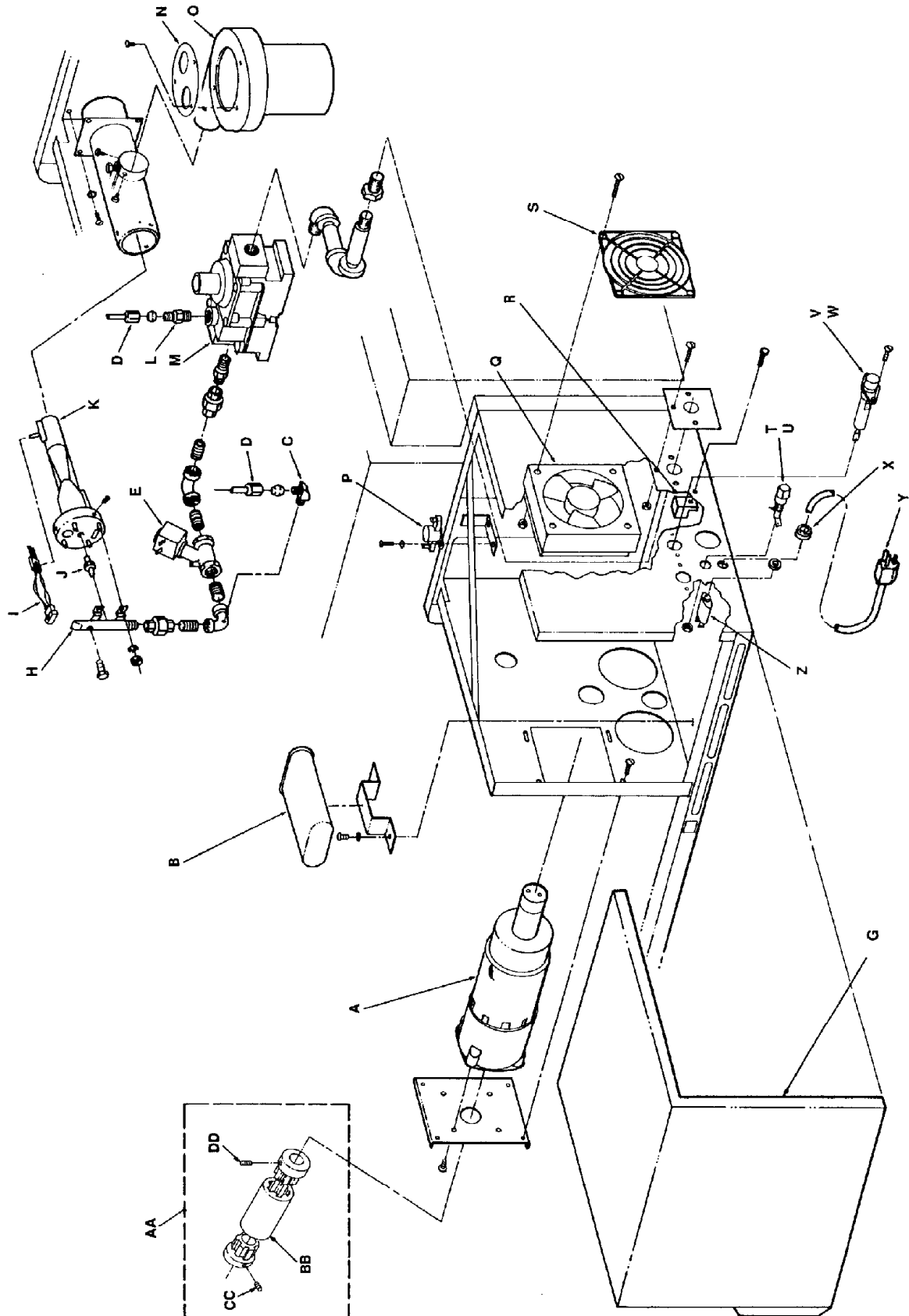

PARTS / CONTROL COMPARTMENT REAR 1116, 1117 S/N 2011383 & ABOVE

LETTER	P/N	DESCRIPTION
A	369682	Back Cover Assembly
B	369901	Manifold Assembly, Burner
C	369398	Solenoid Valve
D	369566	Orifice, Main Burner – Natural
	369524	Orifice, Main Burner – L.P.
E	369552	Hot Surface Igniter
F	369263	Gas Valve, Natural/LP
G	369556	Bypass Orifice Natural
	369557	Bypass Orifice L.P.
H		Bypass Tube Assembly
	369561	Model 1116
	369562	Model 1117
I	369559	90 Degree Connector
J	369568	Venturi Tube, Natural
	369938	Venturi Tube, L.P.
K	369401	Air Shutter Assembly
L	369366	Burner Blower
M	369124	Cooling Fan
N	369331	Finger Guard
O	357067	Thermostat, Hi-Limit
P	369192	Capacitor
Q	369537	Power Cord
R	369538	Strain Relief
S	369129	Fuse Holder
	369166	Fuse, 10 Amp
T	369012	Fuse Holder
	369013	Fuse, 3 Amp
U	353014	Ground Lug
V	369603	Stepper Motor Assembly See Page 67 for Breakdown
W	369268	Set Screw
X	369664	Sleeve Only, Conveyor Drive Coupling
Y	369611	Coupling, Conveyor Drive, Complete
Z	369269	Ball Plunger, Only

BLOW UP / CONTROL COMPARTMENT REAR 1116, 1117 S/N 2011383 & ABOVE

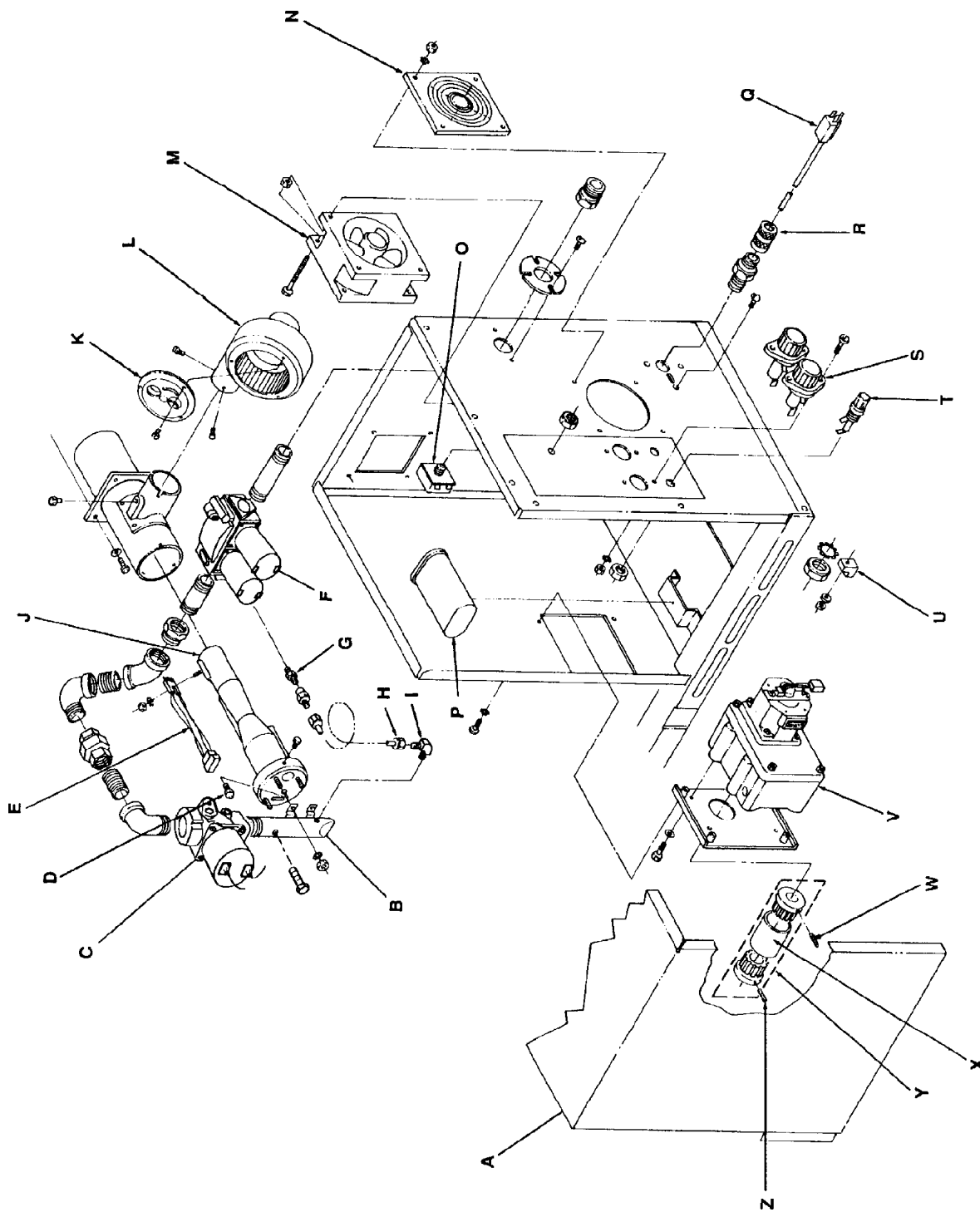

PARTS / OVEN BACK ASSEMBLY 1100 SERIES

LETTER	P/N	DESCRIPTION
A	369182	Fan
B	369899	Shroud, Fan
C	369655	Stand Off
D	369560	Heating Element (200V) Orange
	369183	Heating Element (208V) Red
	369521	Heating Element (220V) Yellow
	369184	Heating Element (240V) Blue
E	369549	Rear Wall Electric Oven
	369976	Rear Wall Gas Oven
F	369581	Motor Support Assembly
G	369181	Motor, Main Fan 208/240V 60HZ
	369196	Motor, Main Fan 240V 50 HZ
	369539	Motor, Main Fan 120V 60 HZ
H	369695	Clamp, Bracket
I	369033	Clamp, Motor
J	369674	Rear Cover Assembly Electric Ovens S/N 2011383 and Below
	370049	Rear Cover Assembly All Ovens S/N 2017384 to 2019884
	369681	Rear Cover Assembly All Ovens S/N 2019885 and Above
	369540	Rear Cover Assembly, Model 1116,1117 S/N 2011383 and below
	369675	Rear Cover Assembly Model 1152-1158 S/N 2011383 and Below
K	369979	High Limit Bracket
L	369227	Catch Spring
M	369541	Thermocouple/Thermistor Bracket

BLOW UP / OVEN BACK ASSEMBLY 1100 SERIES

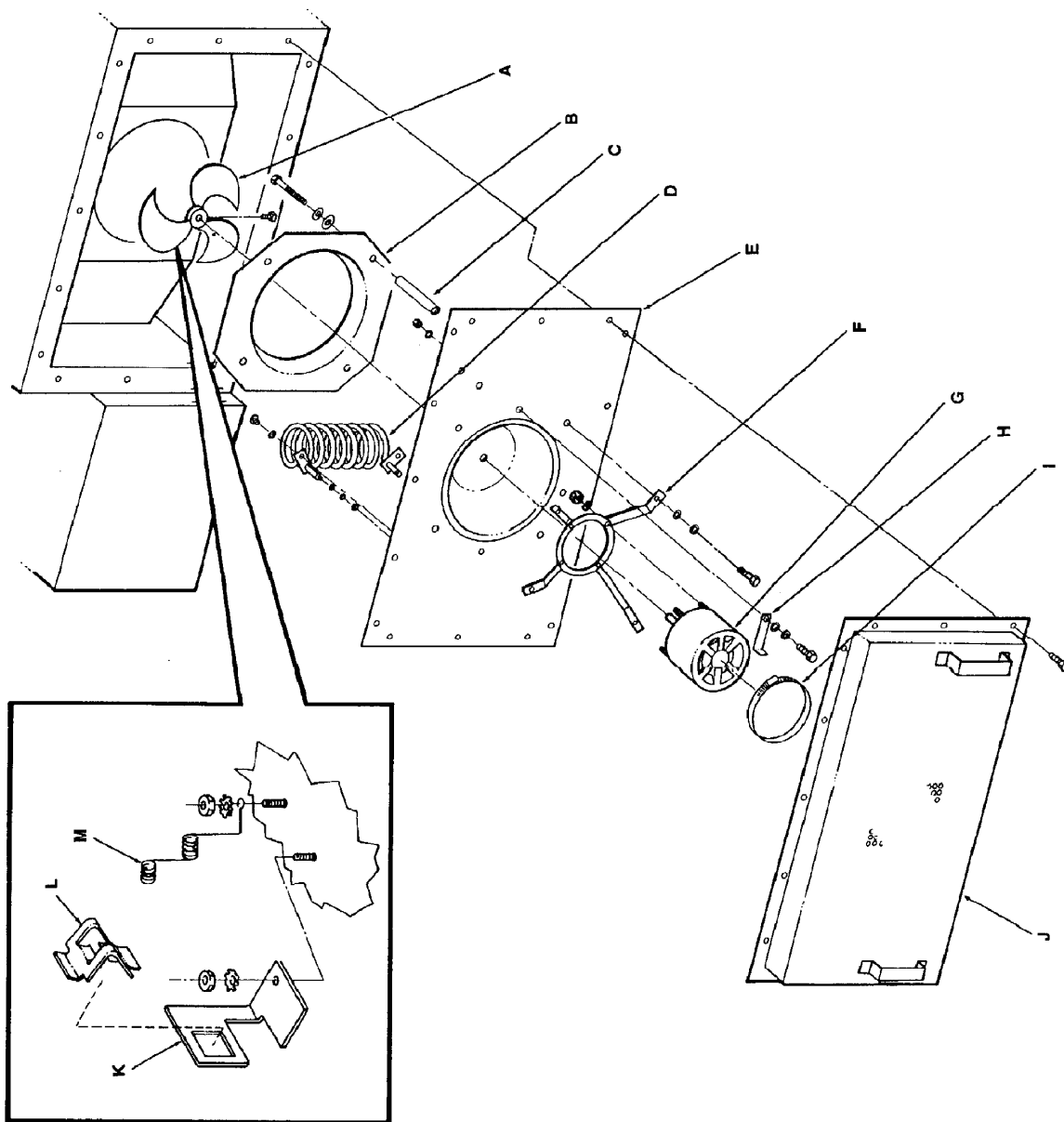

PARTS / GEARMOTOR ASSEMBLY 1100 SERIES

LETTER	P/N	DESCRIPTION
A	369519	Motor, DC –Conveyor
	369384	Motor Brush
B	369294	#4 Lock Washer
C	369296	Screw, 4-40 x ¼
D	369290	Optical Encoder Assembly
E	369151	Coupling And Encoder Disc (.050" Allen Wrench Included)
F	369146	Hex Nut, 4-40
G	369294	#4 Lock Washer
H	369292	Bracket, Tach. Generator
I	369297	Screw, 6-32 x ¼
J	369156	#6 Lock Washer
K	369293	Screw, 4-40 x 3/8
L	NLA	Tach Generator (Replace with 370216)
M	369298	Dust Cover
N	369299	Bushing
O	350247	Screw, 10-32 x 3/8
P	369295	#10 Lock Washer
Q	369603	Stepper Motor Gearbox Assembly (Includes R,S,T)
R	369737	Hall Effect Sensor
S	369658	Screw, 8-32 x ¼
T	369736	Magnet 2 Pole

BLOW UP / GEARMOTOR ASSEMBLY 1100 SERIES

STEPPER GEARMOTOR ASSEMBLY

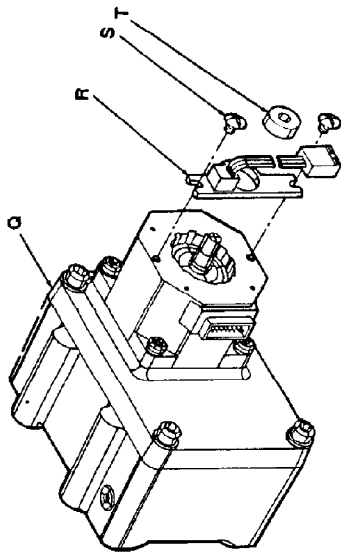

D.C. GEARMOTOR ASSEMBLY

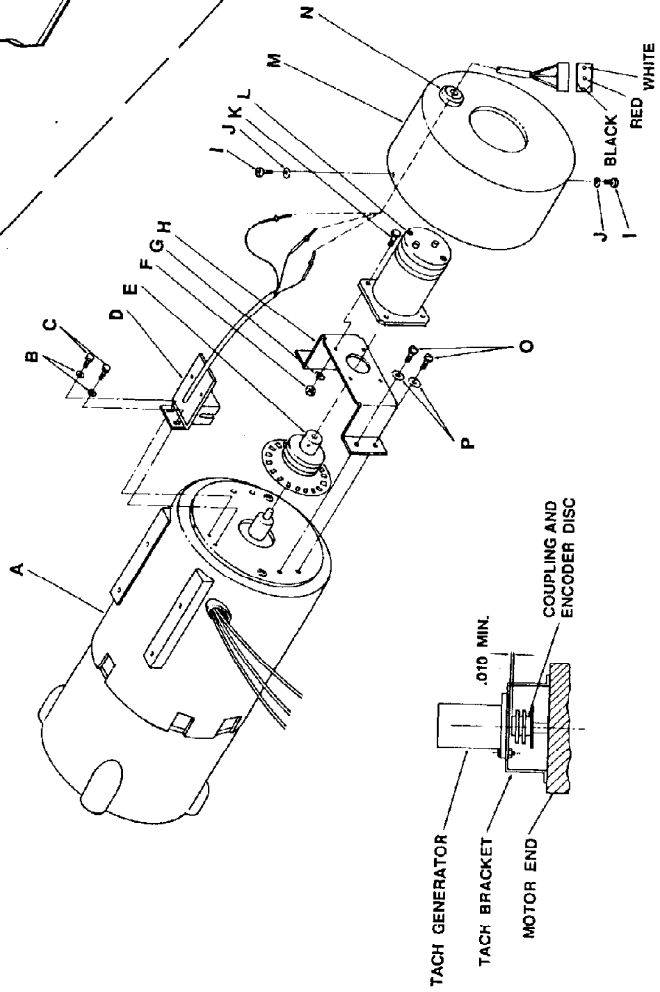

PARTS / CONVEYOR & DOOR 1100 SERIES

LETTER	P/N	DESCRIPTION
A	369190	Conveyor Drive Coupling Model 1100-1106 All Model 1116-1117 S/N 2011382 and Below Model 1130-1151 S/N 2011382 and Below Model 1152-1158 S/N 2011820 and Below Model 1160-1163 S/N 2011977 and Below
	369611	Conveyor Drive Coupling Model 1116-1117 S/N 2011383 and Above Model 1130-1151 S/N 2011383 and Above Model 1152-1158 S/N 2011821 and Above Model 1160-1163 S/N 2011978 and Above
B	369512	Coupling Center Model 1100-1106 All Model 1116-1117 S/N 2011382 and Below Model 1130-1151 S/N 2011382 and Below Model 1152-1158 S/N 2011820 and Below Model 1160-1163 S/N 2011977 and Below
	369664	Coupling Center Model 1116-1117 S/N 2011383 and Above Model 1130-1151 S/N 2011383 and Above Model 1152-1158 S/N 2011821 and Above Model 1160-1163 S/N 2011978 and Above
C	369269	Ball Plunger
D	369268	Set Screw
E	369223	Crumb Pan, Right
F	369224	Crumb Pan, Left
G	369666	Conveyor Frame Assembly
H	369226	Pan Stop
J	369516	Conveyor Bearing
K	369514	Idler Shaft
L	369515	Sprocket
	369978	Set Screw
M	369238	Drive Shaft
N	369513	Hinge
O	369510	Door Assembly, Includes N,P,& Q
P	370016	Impinger Nameplate
Q	369501	Door Latch & Catch
R	1123D	Door with Window Includes N,P,& Q
S	369927	Window Frame Top
T	369925	Glass Access Window
U	369926	Window Frame Bottom
W	369929	Retainer, Window
X	369165	Splice Clips
Y	369194	Conveyor Belt, Complete
	369394	Conveyor Belt, 1 Foot Section

BLOW UP / CONVEYOR & DOOR 1100 SERIES

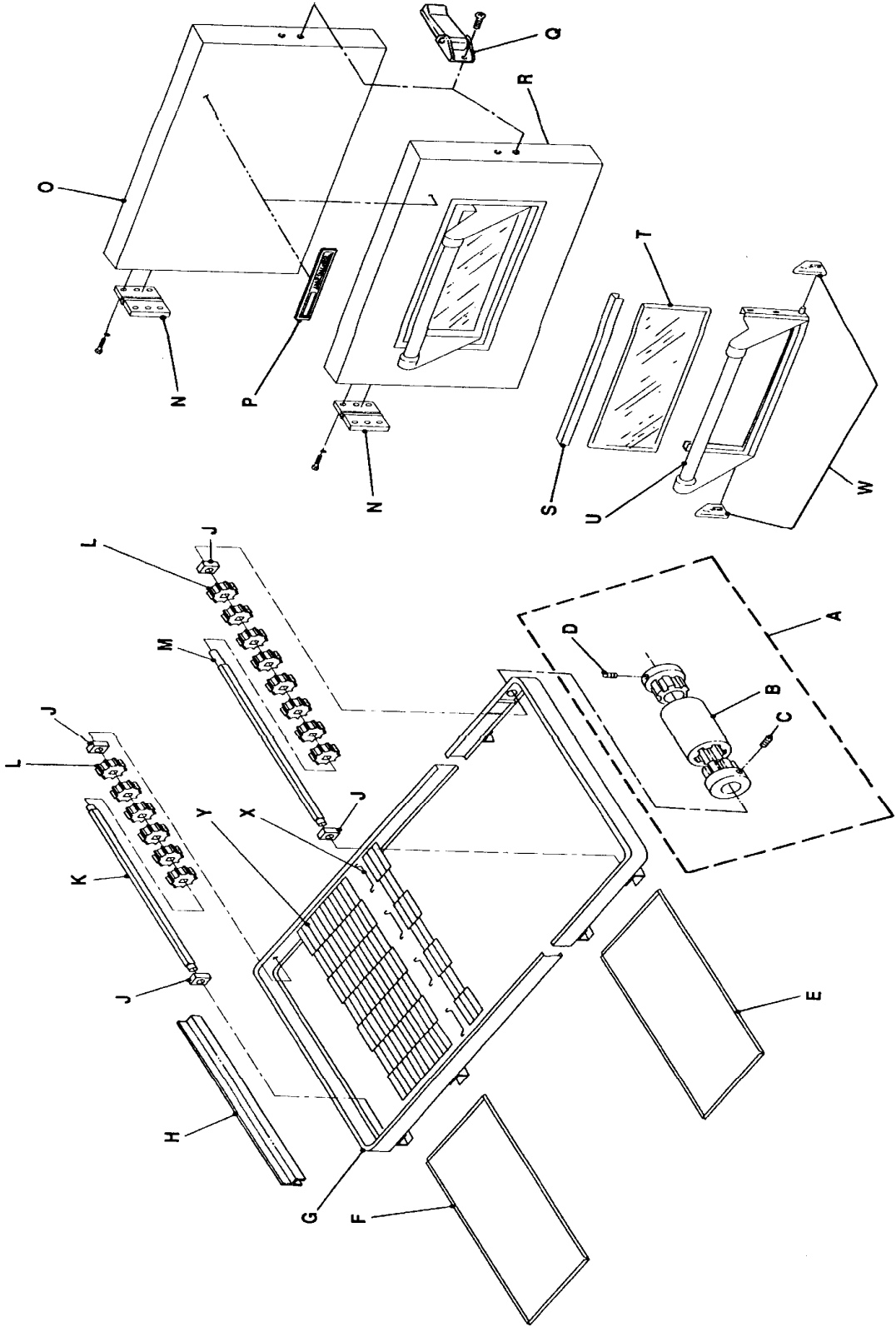

FUSE CHART

MODELS	S. FUSES				
	1 AMP 369195	1 AMP 369335	3 AMP 369013	10 AMP 369166	10 AMP 369014
1100			2	2	
1101			2	2	
1102			2	2	
1103			2	2	
1104	1		2	1	
1105	1		2	1	
1106	1		2	1	
1130			2	2	
1131			2	2	
1132			2	2	
1133			2	2	
1134 BELOW S/N 2003880	1		2	1	
1134 ABOVE S/N 2003879		1	2		1
1135 BELOW S/N 2003880	1		2	1	
1135 ABOVE S/N 2003879		1	2		1
1136 BELOW S/N 2003880	1		2	1	
1136 ABOVE S/N 2003879		1	2		1
1150 BELOW S/N 2003880	1		2	1	
1150 ABOVE S/N 2003879		1	2		1
1151 BELOW S/N 2003880	2			2	
1151 ABOVE S/N 2003879		2			2
1160			2	2	
1161			2	2	
1162			2	2	
1163			2	2	

T. FUSEHOLDERS			
369304	369012	369129	357107
	2	2	
	2	2	
	2	2	
	2	2	
1	2	1	
1	2	1	
1	2	1	
	2	2	
	2	2	
	2	2	
	2	2	
1	2	1	
			4
1	2	1	
			4
1	2	1	
			4
1	2	1	
			4
2		2	
			4
	2	2	
	2	2	
	2	2	
	2	2	

This page intentionally left blank.



Lincoln Foodservice Products, LLC
1111 North Hadley Road
Fort Wayne, Indiana 46804
United States of America

Telephone: (260) 459-8200
U.S. Facsimile: (888) 790-8193
Int'l Facsimile: (260) 436-0735

Technical Service Hotline: (800) 678-9511

www.lincolnfp.com

