



Multi V™, Multi F, and Single Zone Wall Mounted Indoor Units Install Tips

The following pages present an overview of LG's Multi V, Multi F, and Single Zone Wall Mounted indoor units, and is intended to supplement the technical and installation information provided with each product and through www.lghvac.com. The review of basic operation and maintenance skills must reinforce industry established practices and provide helpful tips to make equipment operation successful.

Note:

⊘ *The installation guide is NOT intended to be a replacement for LG installation manuals, nor is it intended to cover ALL the logistics of operating and maintenance of LG wall mounted indoor units. For detailed information on the procedures mentioned here, refer to the installation manual specific to your product. Always comply with applicable local, state, and federal codes.*

Safety Instructions - Installation

⚠ DANGER

⊘ Do not store or use flammable gas or combustibles near the unit.
There is risk of fire, explosion, and physical injury or death.

⚠ WARNING

An authorized, trained technician licensed locally and at the state level must install the unit.
Improper installation by the user may result in fire, explosion, electric shock, physical injury or death.

Wear protective gloves when handling equipment. Sharp edges may cause personal injury.

Always check for system refrigerant leaks after the unit has been installed or serviced.
Exposure to high concentration levels of refrigerant gas may lead to illness or death.

Note:

⊘ Do not install the product where it is exposed directly to ocean winds.
Sea salt in the air may cause the product to corrode. Corrosion, particularly on the condenser and evaporator fins, could cause product malfunction or inefficient operation.

Properly insulate all cold surfaces to prevent "sweating."
Cold surfaces such as uninsulated piping can generate condensate that may drip and cause a slippery surface condition and / or water damage to interior surfaces.

Always check for system refrigerant leaks after the unit has been installed.
Low refrigerant levels may cause product failure.

⚠ CAUTION

Be very careful when transporting the product. There is a risk of the product falling and causing physical injury.
Use appropriate moving equipment to transport each frame; ensure the equipment is capable of supporting the weight of the equipment.

Dispose the packing materials safely.
Packing materials, such as nails and other metal or wooden parts, may cause puncture wounds or other injuries. Tear apart and throw away plastic packaging bags so that children may not play with them and risk suffocation and death.

Install the unit considering the potential for strong winds or earthquakes.
Improper installation may cause the unit to fall over, resulting in physical injury or death.

Keep the unit upright during installation to avoid vibration or water leakage.

When connecting refrigerant tubing, remember to allow for pipe expansion.
Improper piping may cause refrigerant leaks and system malfunction.

⊘ Do not install the unit in a noise-sensitive area. Periodically check that the outdoor frame is not damaged.
There is a risk of equipment damage.

Install the unit in a safe location where nobody can step on or fall onto it. ⊘ Do not install the unit on a defective stand.
There is a risk of unit and property damage.

Install the unit in a safe location where nobody can step on or fall onto it. ⊘ Do not install the unit on a defective stand.
It may result in an accident that causes physical injury or death.

Properly insulate all cold surfaces to prevent "sweating."
Cold surfaces such as uninsulated piping can generate condensate that could drip, causing a slippery surface that creates a risk of slipping, falling, and personal injury.

Install the drain hose to ensure adequate drainage.
There is a risk of water leakage and property damage.

⊘ Do not store or use flammable gas / combustibles near the unit.
There is a risk of product failure.

⊘ Do not use this equipment in mission critical or special-purpose applications such as preserving foods, works of art, wine coolers or refrigeration. This equipment is designed to provide comfort cooling and heating.

Safety Instructions - Wiring

⚠ DANGER

High voltage electricity is required to operate this system. Adhere to the U.S. National Electric Code (NEC) and these instructions when wiring.
Improper connections and inadequate grounding can cause accidental injury or death.

⚠ WARNING

The information contained in this manual is intended for use by an industry-qualified, experienced, certified electrician familiar with the NEC who is equipped with the proper tools and test instruments.
Failure to carefully read and follow all instructions in this manual can result in equipment malfunction, property damage, personal injury or death.

Refer to local, state, and federal codes, and use power wires of sufficient current capacity and rating.
Wires that are too small may generate heat and cause a fire.

Note:

⊘ Do not supply power to the unit until all electrical wiring, controls wiring, piping, installation, and refrigerant system evacuation are completed.

Always ground the unit following local, state, and NEC codes.
There is risk of fire, electric shock, and physical injury or death.

All electric work must be performed by a licensed electrician and conform to local building codes or, in the absence of local codes, with the NEC, and the instructions given in this manual.
If the power source capacity is inadequate or the electric work is not performed properly, it may result in fire, electric shock, physical injury or death.

Secure all field wiring connections with appropriate wire strain relief.
Improperly securing wires will create undue stress on equipment power lugs. Inadequate connections may generate heat, cause a fire and physical injury or death.

Properly size all circuit breakers or fuses.
There is risk of fire, electric shock, explosion, physical injury or death.

Properly tighten all power lugs.
Loose wiring may overheat at connection points, causing a fire, physical injury or death.

⊘ Do not change the settings of the protection devices.
If the pressure switch, thermal switch, or other protection devices are bypassed or forced to work improperly, or parts other than those specified by LG are used, there is risk of fire, electric shock, explosion, and physical injury or death.

Wall Mounted Indoor Units Installation Tips

This document contains general installation tips for installing LG Wall Mounted indoor units (IDU). Follow all applicable local and national codes during installation. For more detailed information, refer to the individual unit's installation manual on www.lghvac.com/resources.

The typical unit installation includes:

- Selecting the installation location
- Installing the unit
- Connecting refrigerant pipes
- Connecting drain pipe
- Connecting communication and power wiring
- Installing the remote controller (if applicable)

Note:

Always follow your system diagrams, including the LATS diagram (if applicable).

⚠ DANGER

⊗ To avoid the possibility of fire, do not install the unit in an area where combustible gas may generate, flow, stagnate, or leak. Failure to do so will cause serious bodily injury or death.

Note:

Select a location for installing the Wall Mounted IDU that meets the following conditions:

- Where there is enough structural strength to bear the weight of the unit.
- Operating sound from the unit will not disturb occupants.
- Include enough space for service access.
- Include space for drainage to ensure condensate flows properly out of the unit when it is in cooling mode.
- Use a level indicator to ensure the unit is installed on a level plane.
- Includes space for drainage to ensure condensate flows properly out of the unit when it is in cooling mode.

Note:

The unit may be damaged, may malfunction, and / or will not operate as designed if installed in any of the conditions listed.

- ⊗ Do not install the unit near a heat or steam source, or where considerable amounts of oil, iron powder, or flour are used. These materials may generate condensate, cause a reduction in heat exchanger efficiency, or malfunction of the condensate drain. If this is a potential problem, install a ventilation fan large enough to vent out these materials.
- ⊗ Do not install the unit where it will be subjected to direct thermal radiation from other heat sources.
- ⊗ Do not install the unit in an area where combustible gas may generate, flow, stagnate, or leak. There is the possibility of fire.
- ⊗ Do not install the unit in a location where acidic solution and spray (sulfur) are often used.
- ⊗ Do not use the unit in environments where oil, steam, or sulfuric gas are present.
- ⊗ Do not install additional ventilation products on the chassis of the unit.
- ⊗ Do not install the unit near high-frequency generator sources.
- ⊗ Do not install the unit near a doorway.

⊗ Indoor units (IDUs) must not be placed in an environment where the IDUs may be exposed to harmful volatile organic compounds (VOCs) or in environments where there is improper air make up or supply or inadequate ventilation. If there are concerns about VOCs in the environment where the IDUs are installed, proper air make up or supply and/or adequate ventilation must be provided. Additionally, in buildings where IDUs will be exposed to VOCs, consider a third party factory-applied epoxy coating to the fan coils for each IDU where the entire coil is dipped, not sprayed.

• If the unit is installed near a body of water, the installation parts are at risk of corroding. Appropriate anti-corrosion methods must be taken for the unit and all installation parts.

Installing in an Area Exposed to Unconditioned Air

In some installation applications, areas (floors, walls) in some rooms may be exposed to unconditioned air (room may be above or next to an unheated garage or storeroom). To countermeasure:

- Verify that carpet is or will be installed (carpet may increase the temperature by three [3] degrees).
- Add insulation between the floor joists.
- Install radiant heat or another type of heating system to the floor.

Typical Art Cool Gallery IDU minimum clearances.

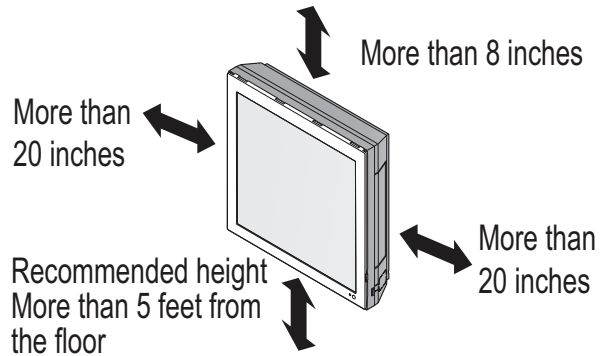

Typical Wall Mounted IDU minimum clearances.

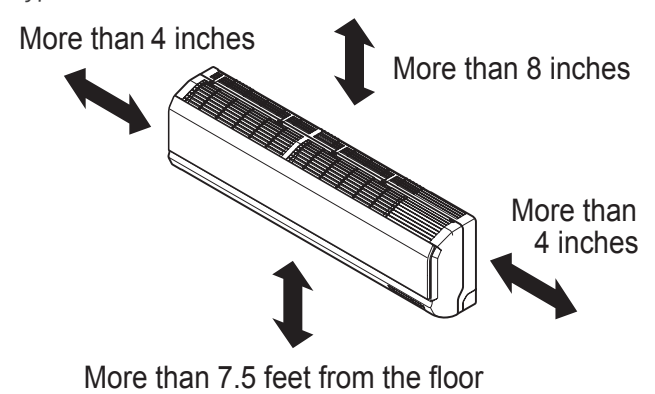

Installing IDU near a heat or steam source.

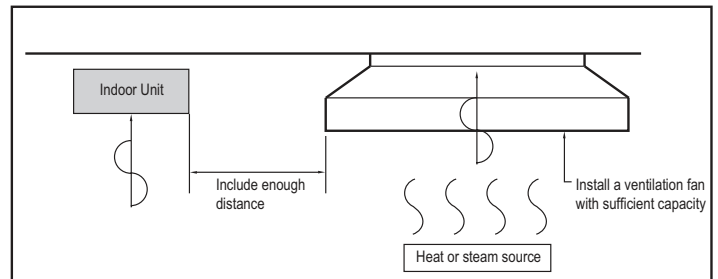

▲WARNING

- When choosing a location for the indoor unit, be sure to take into consideration routing of wiring for power outlets within the wall. Contacting wiring can cause serious bodily injury or death.
- Use caution when drilling holes through the walls for the purposes of piping connections. Power wiring can cause serious bodily injury or death.
- Mounting hardware must be securely installed to prevent the unit falling from its installation location. There is risk of injury or property damage from falling equipment.
- Installation work must be performed by trained personnel and in accordance with all local or other applicable codes. There is risk of injury to personnel from incorrect installation.

General Guidelines for Wall Mounted Indoor Units

1. Mount the installation plate horizontally by aligning the center line using a leveling tool. Use the type "A" screws that are factory-supplied with the plate.
- If mounting the unit on concrete, consider using anchor bolts. Use a level to ensure the plate is level.
2. Observe all rear piping clearances when drilling into the wall.
3. To mount the indoor unit to the installation plate, attach the three hooks on the top of the indoor unit to the top edge of the installation plate.
4. Verify the hooks are properly attached to the installation plate by gently shaking the indoor unit from side to side.
5. To fully anchor the indoor unit to the wall, push the bottom of the indoor unit against the installation plate until the bottom hooks snap into their slots (a click will be heard).

Typical Wall Mounted IDU Installation Plate.

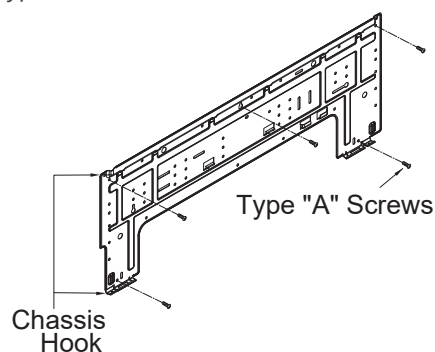

Locking the Wall Mounted IDU onto the Installation Plate.

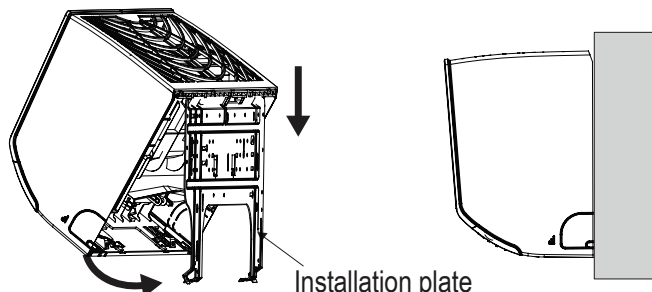

General Guidelines for Art Cool Gallery Indoor Units

1. Choose an appropriate location for the indoor unit. To hang the installation guide, verify that it is level and plumb, and then tape it to the wall.
2. Drill holes for the mounting screws. Drill hole for the field-installed refrigerant and drain piping.
3. To hang the Gallery indoor unit, remove the installation guide and hang the indoor unit on the top two screws. Verify the indoor unit is hanging securely on the screws.
4. Align the holes at the bottom of the indoor unit to the mounting holes. Tighten first the top screws, then tighten the bottom screws.
5. Verify that the Gallery indoor unit is completely secured to the wall by gently shaking it up and down.

Typical Art Cool Gallery IDU Installation.

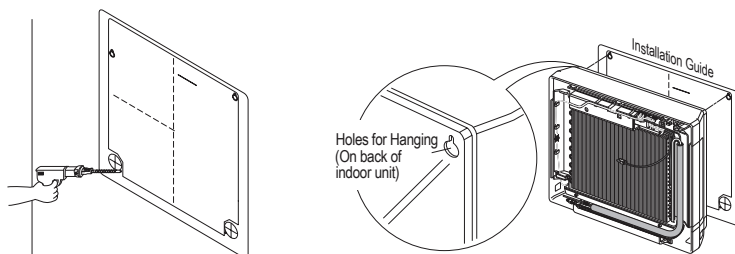

For detailed installation information, refer to the individual unit's installation manual on www.lghvac.com/resources.

Piping and Wiring

Wall-mounted indoor units have several options on how the piping and wiring can be routed.

- Whichever way the piping and wiring are routed out of the indoor units, the mounting wall on which the indoor unit is installed should be strong and solid enough to protect it from vibration.

Note:

- Bending in a violent right-to-left motion could damage the piping.
- Bending the piping directly left or right, without bending it downward first, may cause damage.
- Do not twist the piping.
- Do not bend the piping towards the front of the unit because this may damage the indoor unit.

Typical Wall Mounted Indoor Unit Piping/Wiring Routes.
Piping / Drain Hose Holder

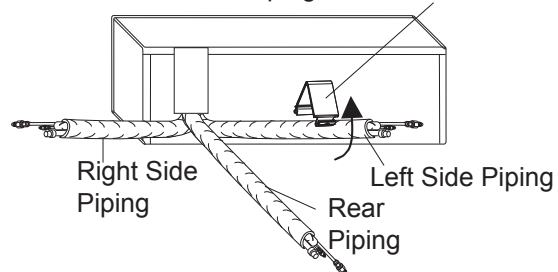

Typical Art Cool Gallery Indoor Unit Right Side Piping Access.

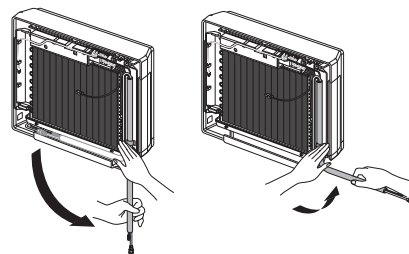

Connecting Refrigerant Pipes

Refrigerant Pipe Connections

Indoor units come with flare type connections. It is the installer's option to use the flare fittings provided or braze the indoor unit to the refrigerant piping system.

Flare Fittings

- All unit flare fittings are 45° and are rated for high-pressure R410A refrigerant.
- Properly form all flare fittings using best practices.
- Place a drop of PVE oil on the outside of flare fitting before tightening.

Note:

- Do not use any other type of oil (including traditional POE refrigeration oil) as a lubricant. Failure to follow this procedure may lead to restrictions in the refrigeration components.
- Do not over-tighten flare nuts. Excessive tightening will cause fittings to crack.

Typical Refrigerant Line Flare Fitting Insulation Detail

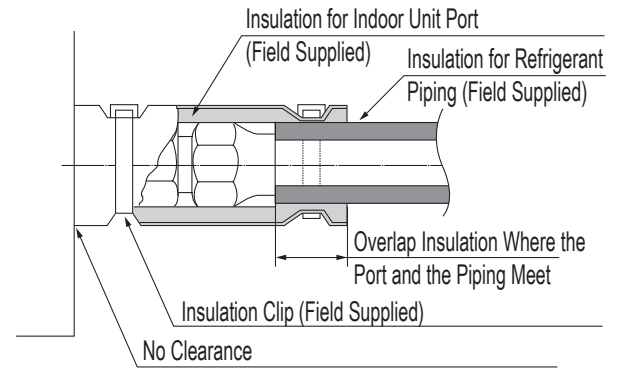

Brazing

Use a dry nitrogen purge operating at a minimum pressure of three (3) psig and maintain a steady flow.

Use a 15% silver phosphorous copper brazing alloy to avoid overheating and produce good flow.

Protect isolation valves, electronic expansion valves, and other heat-sensitive components from excessive heat with a wet rag or heat barrier spray.

Note:

Multi V refrigeration system components contain very small capillary tubes, small orifices, electronic expansion valves, oil separators, and heat exchangers that can easily become blocked.

Insulate Refrigerant Pipes

Sufficiently insulate all cold surfaces to prevent moisture forming. All pipes must be insulated and each pipe must be separately wrapped. Use field-provided one-half (1/2) inch thick (or thicker) closed-cell insulation. The thickness may need to be increased based on ambient conditions and local codes.

Wrap all refrigerant and condensate piping. Glue all insulation joints with no air gaps between insulation segments, and between insulation segments and the unit case. Ensure insulation material fits snugly against the refrigeration pipe with no air space between the pipe surface and the surrounding insulation.

Protect insulation inside hangers and supports with a second insulation layer. Ensure insulation on all pipe passing through pipe hangers, inside conduit, and/or sleeves is not compressed.

Connecting the Drain Pipe

Gravity Drain Pipe

All Gallery and Wall Mounted indoor units apply the gravity drain method. Depending on the location of the indoor unit, condensation can be drained directly to the outside of the building, or a common indoor unit drainage piping system can be installed.

Drain Hose

Gallery and Wall Mounted indoor units have a built-in drain hose. If necessary, the drain hose can be extended.

- When the bottom surface of the indoor unit is at an elevation below the receiving building drain line connection, install an inverted trap at the top of the condensate pump discharge riser before connection to the building drain pipe.
- When the receiving drain line is mounted horizontal, connect the inverted trap to the top half of the pipe. The connection point of the inverted trap to the building drain pipe should always be to the top half of the pipe and should never be over 45° either side of the upper most point of the horizontal building drain line.
- If connecting to a vertical drain line or plumbing system vent line, connect the IDU condensate pump discharge line using a Y-45 fitting with the double end of the Y-45 fitting facing up. When connecting to a vertical drain line include an inverted trap at the top of the IDU condensate pump discharge riser before connection to the Y-45 fitting.

Drain Piping

- Drain piping must have down slope (1/50 to 1/100).
- Any holes through the ceilings, walls, etc., must be large enough to accommodate the drain piping and insulation.

- To prevent reversal flow, do not provide up and down slope.
- Do not exert extra force on the drain port on the indoor unit during drain piping connection.

Typical Indoor Unit with a Gravity Drain.

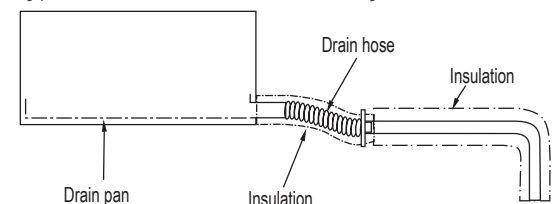

Typical Indoor Unit Drain Piping Slope.

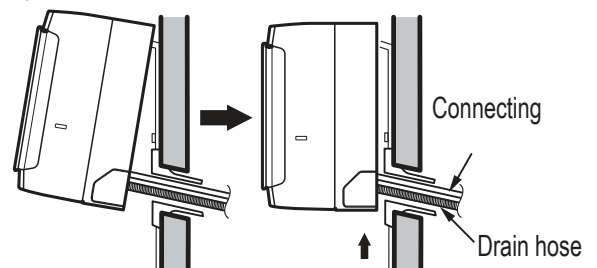

Multi V Indoor Unit Wiring Configuration

Indoor unit installation best practices are to connect control wiring (low voltage) and then connect power wiring (high voltage). Multi VIDUs require separate power and communication cables. The IDU requires single-phase, 208-230 volt facility power. Be sure the power cables meet applicable local and national codes.

Communications cable from the outdoor unit must be minimum 18 AWG, 2-conductor, twisted, stranded and shielded.

- Polarity matters for communication cable. When connecting the communications cable conductors at each Multi V system component, be careful the conductor connected to the IDU(A) terminal on the outdoor unit is connected to the A/3(A) terminal at each indoor unit. The conductor connected to the IDU(B) terminal on the outdoor unit must be connected to the B/4(B) terminals at each indoor unit. Cross connecting the A/3(A) and B/4(B) terminals will cause communications errors and system malfunction.
- Keep communications cables away from line voltage wiring, lighting ballasts, and other devices emitting EMF energy. Maintain a minimum of two (2) inches between line voltage wires and communications or zone controller cables.
- The outdoor/indoor unit communications cable must be run between components in a daisy chain configuration. Ⓞ Star or wye configurations are not allowed.
- Connect the communications cables to the A/3(A) and B/4(B) terminals at indoor units and/or heat recovery units. Maintain polarity throughout the communications bus. Be sure A/3(A) terminals are connected to A/3(A) terminals and B/4(B) terminals are connected to B/4(B) terminals.
- Ensure the communication cable shield is properly grounded to the Master ODU chassis only.
- Ⓞ Do not ground the ODU to IDUs / HRUs communication cable at any other point. Wiring must comply with all applicable local and national codes.

▲WARNING

Connect the indoor unit input power cable but Ⓞ do not apply power to the indoor unit until authorized to do so by the system commissioning agent.
Inappropriate power connection can result in personal injury or death.

Terminal screws may loosen during transport. Properly tighten the terminal connections during installation or risk electric shock, physical injury or death.

Loose wiring may cause unit the wires to burnout or the terminal to overheat and catch fire. There is a risk of electric shock, physical injury or death.

Typical Multi V Wall Mounted IDU Power Wiring / Communications Cable Terminals.

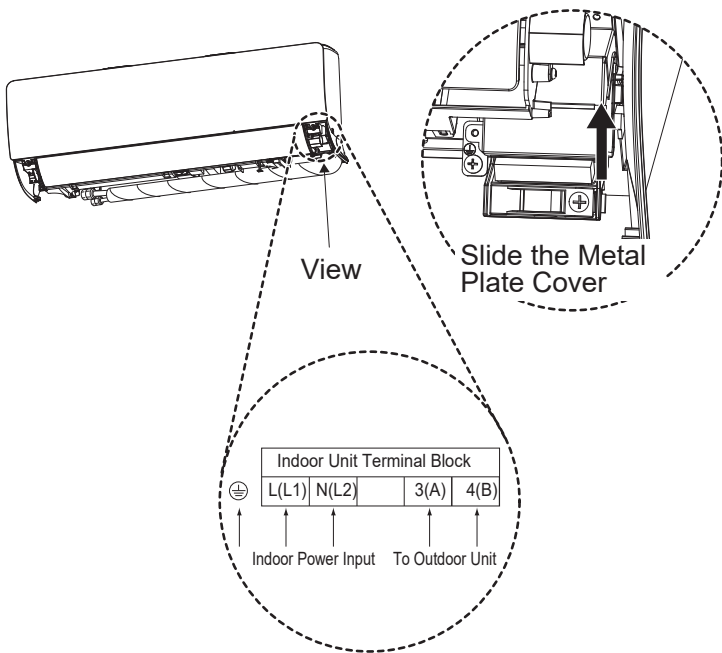

Typical Multi V Art Cool Gallery IDU Power Wiring / Communications Cable Terminals.

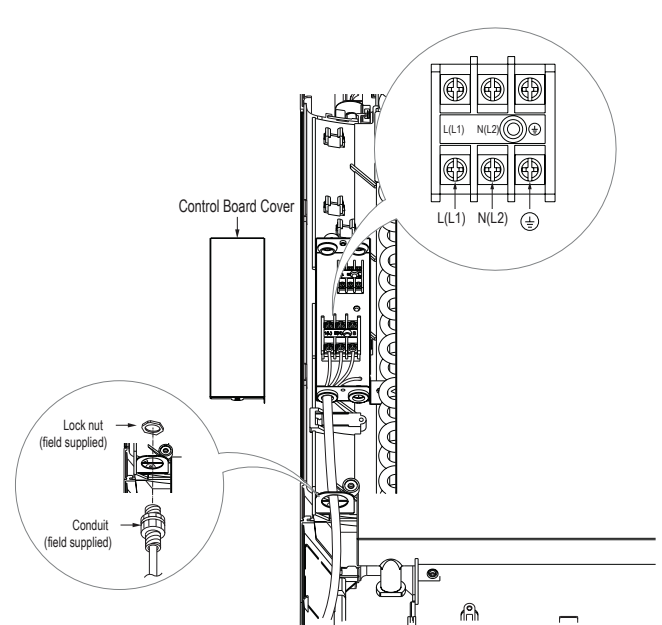

Multi F and Single Zone Indoor Unit Wiring Configuration

Multi F and Single Zone IDUs have a single cable from the outdoor unit that supplies both power and communication.

This field-supplied cable must be minimum 14 AWG, 4-conductor, stranded, and shielded. Wiring must comply with all applicable local and national codes.

- Ensure that the power conductors are connected to the line power terminals of the IDU.
- Ensure that the communication conductor is connected to the communication terminal of the IDU and ground is connected to ground.

Note:

- Ⓞ Never connect zone controllers or other central control products such as AC Smart, PDI, or LG building management system gateway products to the IDU/ODU communications cable.
- Ⓞ Never use wire caps and never splice communications cables.

Typical Multi F and Single Zone IDU Power Wiring and Communications Cable Terminals.

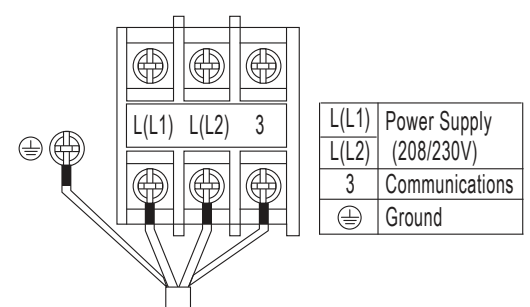

Single Zone Communication / Connection (Power) Cable Specifications: Outdoor Unit to Indoor Unit

- For communication / connection (power) wires between the Single Zone outdoor unit and the indoor unit for lengths up to 130 feet, use a minimum 14 AWG, 4-conductor, stranded, shielded or unshielded wire. If shielded, the wire must be grounded to the chassis at the outdoor unit only. Wiring must comply with all applicable local and national codes.
 - When the communication / connection (power) wires between the indoor unit and outdoor unit is GREATER THAN 130 feet, use:
 - A two (2) conductor wire for power.
 - A two (2) conductor wire for communication / ground.
 - Separate the power AT LEAST two (2) inches away from the communication / ground wire.
 - All wiring must be a minimum 14 AWG, stranded, shielded, or unshielded as cited above.
- Insulation material as required by local code.
- Firmly attach the cable; provide slack but secure in a way to prevent external forces from being imparted on the terminal block.
- Wiring must be completed without splices.

Typical Single Zone System when wiring is greater than 130 feet.

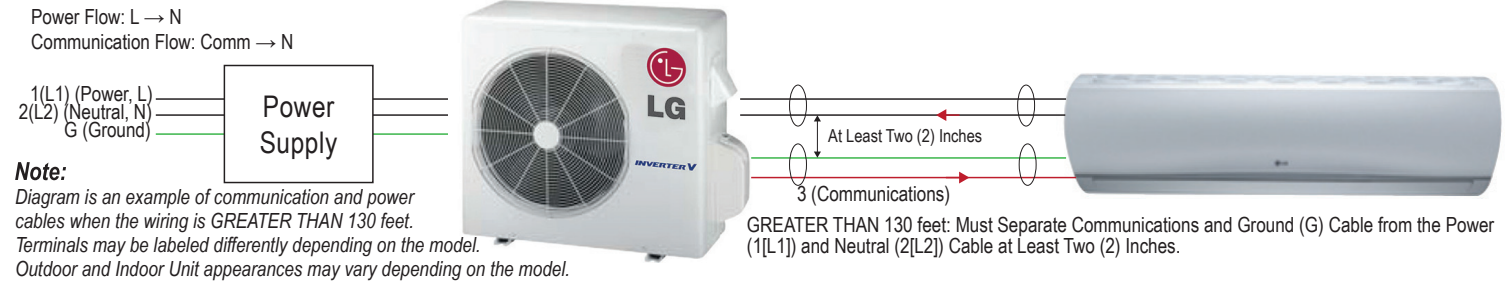

Wired Wall Controller Installation.

Since the room temperature sensor is inside the remote controller, the remote controller should be installed in a place away from direct sunlight, high humidity and direct supply of hot or cold air to maintain proper space temperature. Install the remote controller about 5 ft above the floor in an area with good air circulation and an average temperature.

⊘ Do not install the remote controller where it can be affected by the following:

- Drafts or dead spots behind doors and in corners
- Hot or cold air from ducts
- Radiant heat from sun or appliances
- Concealed pipes and chimneys
- Uncontrolled areas such as an outside wall behind the remote controller

1. Pull communications cable between the zone controller handy box (if used) and the indoor unit. Use field supplied 22 AWG, 3-conductor, twisted, stranded and unshielded cable or LG supplied cable. Wiring must comply with all applicable local and national codes.
2. Store a minimal amount of cable in the handy box. Any additional cable should be coiled and stored near the indoor unit control panel.
3. If using LG cable and additional cable length is needed, order a thirty-three (33) foot LG Wired Remote Group Control Extension cable (Model No. PZCWRC1).
4. If using LG supplied cable and the cable between the zone controller and the indoor unit is too long, ⊘ do not cut the cable and shorten. Coil any spare communications cable, tie-wrap it, and leave it next to the indoor unit location.

Typical Wired Remote Controller Installation.

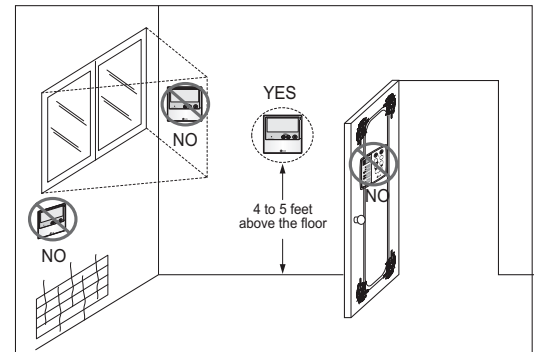

To access the complete Installation Manual for each unit, visit:
www.lghvac.com/resources

This document, as well as all reports, illustrations, data, information, and other materials are the property of LG Electronics U.S.A., Inc., and are disclosed by LG Electronics U.S.A., Inc. only in confidence.

Due to our policy of continuous product innovation, some specifications may change without notification.

©LG Electronics U.S.A., Inc., Englewood Cliffs, NJ. All rights reserved. "LG" is a registered trademark of LG Corp."