



MULTI VTM

WALL MOUNTED INDOOR UNIT ENGINEERING MANUAL



Art CoolTM Mirror Wall Mounted
5,500 to 24,200 Btu/h



Standard Wall Mounted
5,500 to 35,500 Btu/h



Art CoolTM Gallery Wall Mounted
9,600 and 12,300 Btu/h

PROPRIETARY DATA NOTICE





**This document, as well as all reports, illustrations, data, information, and other materials are the property of LG Electronics U.S.A., Inc., and are disclosed by LG Electronics U.S.A., Inc. only in confidence.
This document is for design purposes only.**

A summary list of safety precautions is on page 3.

To access additional technical documentation such as submittals, outdoor unit engineering manuals, installation, service, product data performance, general best practice, and building ventilation manuals, as well as white papers, catalogs, LATS software programs, and more, log in to www.lghvac.com.

Unit Nomenclature.....	4	Standard Wall-Mounted Indoor Units	65-113
LATS Overview	5-6	<i>Mechanical Specifications</i>	66-67
Refrigerant Charge Worksheet.....	7-9	<i>General Data</i>	68-69
Art Cool™ Gallery Indoor Units	10-23	<i>Electrical Data</i>	70
<i>Mechanical Specifications</i>	11	<i>External Dimensions</i>	71-73
<i>General Data</i>	12	<i>Electrical Wiring Diagram</i>	74-75
<i>Electrical Data</i>	13	<i>Refrigerant Flow Diagram</i>	76
<i>External Dimensions</i>	14	<i>Acoustic Data</i>	77-80
<i>Electrical Wiring Diagram</i>	15	<i>Air Velocity / Temperature Distribution</i>	81-95
<i>Refrigerant Flow Diagram</i>	16	<i>Capacity Tables</i>	96-113
<i>Acoustic Data</i>	17-18	Application Guidelines.....	114-122
<i>Air Velocity / Temperature Distribution</i>	19	<i>Selecting the Best Location</i>	115
<i>Capacity Tables</i>	20-23	<i>General Mounting</i>	116-117
Art Cool™ Mirror Wall-Mounted Indoor Units	24-64	<i>General Drain Piping Information</i>	118-119
<i>Mechanical Specifications</i>	25-26	<i>Wiring Guidelines</i>	120-122
<i>General Data</i>	27	<i>Wired Controller Placement</i>	122
<i>Electrical Data</i>	28	Acronyms	123
<i>External Dimensions</i>	29-30		
<i>Electrical Wiring Diagram</i>	31		
<i>Refrigerant Flow Diagram</i>	32		
<i>Acoustic Data</i>	33-36		
<i>Air Velocity / Temperature Distribution</i>	37-50		
<i>Capacity Tables</i>	51-64		

TABLE OF SYMBOLS

 DANGER	<i>This symbol indicates an imminently hazardous situation which, if not avoided, will result in death or serious injury.</i>
 WARNING	<i>This symbol indicates a potentially hazardous situation which, if not avoided, could result in death or serious injury.</i>
 CAUTION	<i>This symbol indicates a potentially hazardous situation which, if not avoided, may result in minor or moderate injury.</i>
Note	<i>This symbol indicates situations that may result in equipment or property damage accidents only.</i>
	<i>This symbol indicates an action must not be completed.</i>

UNIT NOMENCLATURE

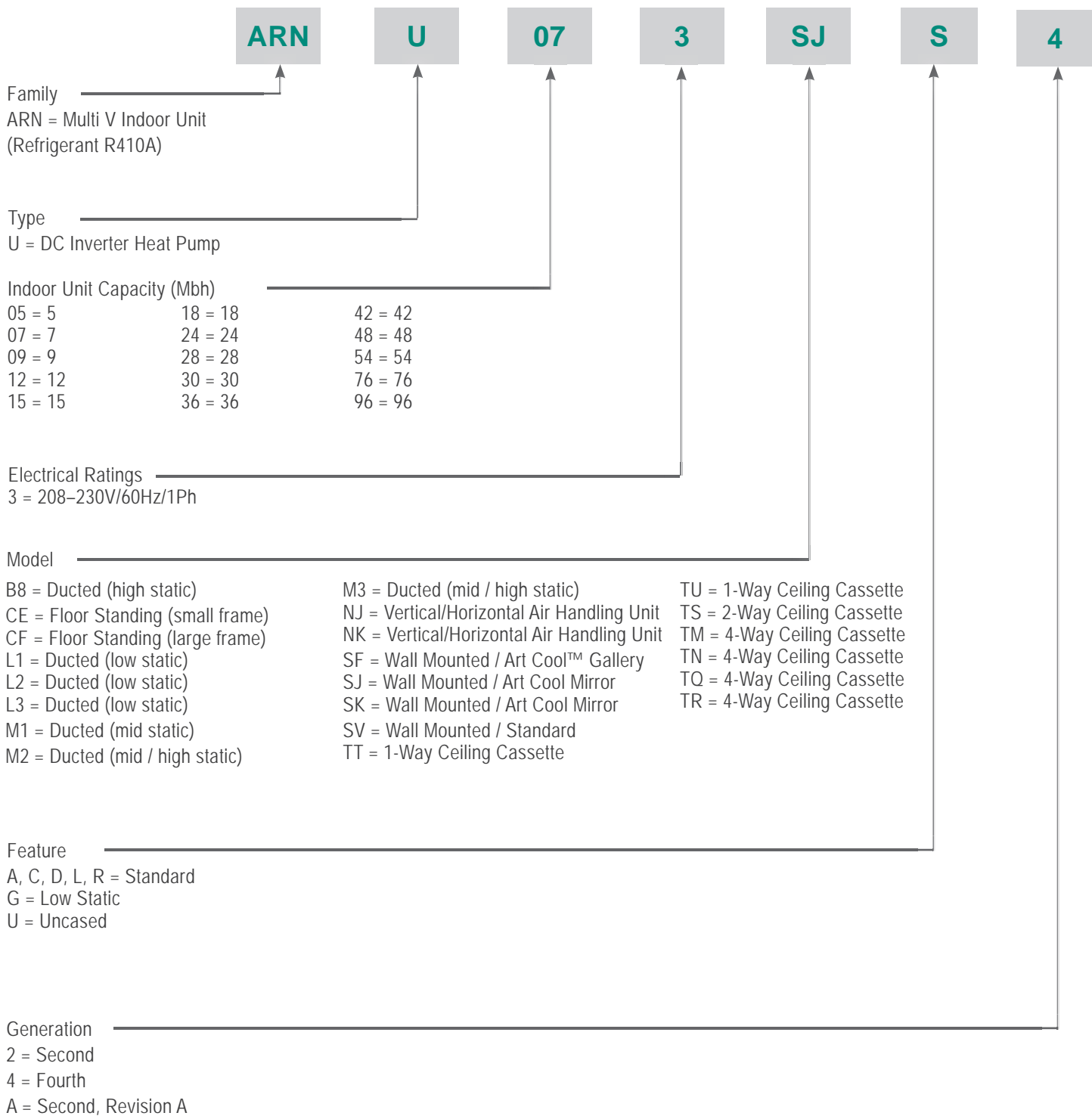

LG Air Conditioner Technical Solution (LATS) Software

A properly designed and installed refrigerant piping system is critical to the optimal performance of LG air-conditioning systems. To assist engineers, LG offers, free of charge, LG Air Conditioner Technical Solution (LATS) software—a total design solution for LG air conditioning systems.

Note:

To reduce the risk of designing an improper applied system or one that will not operate correctly, LG requires that LATS software be used on all projects.

Formats

LATS is available to LG customers in two user interfaces: LATS HVAC and LATS REVIT. Both LATS formats are available at www.myLGHVAC.com, or contact an LG Sales Representative.

LATS HVAC is a Windows®-based application that aids engineers in designing LG Variable Refrigerant Flow (VRF), Multi F / Multi F MAX, Single-Zone, and Energy Recovery Ventilator (ERV) systems.

**Windows® is a registered mark of Microsoft® Corporation.*

LATS Revit integrates the LG LATS program with Revit® software**. It permits engineers to layout and validate Multi V VRF systems directly into Revit drawings.

***AutoCAD® and Revit® are both registered marks of Autodesk, Inc.*

Features

All LG product design criteria have been loaded into the program, making LATS simple to use: double click or drag and drop the component choices. Build systems in Tree Mode where the refrigerant system can be viewed. Switch to a Schematic diagram to see the electrical and communications wiring.

LATS software permits the user to input region data, indoor and outdoor design temperatures, modify humidity default values, zoning, specify type and size of outdoor units and indoor units, and input air flow and external static pressure (ESP) for ducted indoor units.

The program can also do the following:

- Import building loads from a separate Excel file.
- Present options for outdoor unit auto selection.
- Automatically calculate component capacity based on design conditions for the chosen region.
- Verify if the height differences between the various system components are within system limits.
- Provide the correct size of each refrigerant piping segment and LG Y-Branches and Headers.
- Adjust overall piping system length when elbows are added.
- Check for component piping limitations and flag if any parameters are broken.
- Factor operation and capacity for defrost operation.
- Calculate refrigerant charge, noting any additional trim charge.
- Suggest accessories for indoor units and outdoor units.
- Run system simulation.

Note:

Features depend on which LATS program is being used, and the type of system being designed.

Figure 1: Example of LATS CAD2.



LG AIR CONDITIONER TECHNICAL SOLUTION (LATS)



LATS Generates a Complete Project Report

LATS software also generates a report containing project design parameters, cooling and heating design data, system component performance, and capacity data. The report includes system combination ratio and refrigerant charge calculations; and provides detailed bill of material, including outdoor units, indoor units, control devices, accessories, refrigerant pipe sizes segregated by building, by system, by pipe size, and by pipe segments. LATS can generate an Excel GERP report that can imported into the LG SOPS pricing and ordering system.

Proper Design to Install Procedure

LG encourages a two report design-to-install-procedure. After the design engineer determines building / zone loads and other details, the engineer opens the LATS program and inputs the project's information. When the design is complete, the "Auto Piping" and "System Check" functions must be used to verify piping sizes, limitations, and if any design errors are present. If errors are found, engineers must adjust the design, and run Auto Piping and System Check again. When the design passes the checks, then the engineer prints out a project "Shop Drawing" (LATS Tree Diagram) and provides it to the installing contractor. The contractor must follow the LATS Tree Diagram when building the piping system, but often-times the design changes on the building site:

- Architect has changed location and/or purpose of room(s).
- Outdoor unit cannot be placed where originally intended.
- Structural elements prevent routing the piping as planned.
- Air conditioning system conflicts with other building systems (plumbing, gas lines, etc.).

Figure 2: Example of a LATS Tree Diagram.

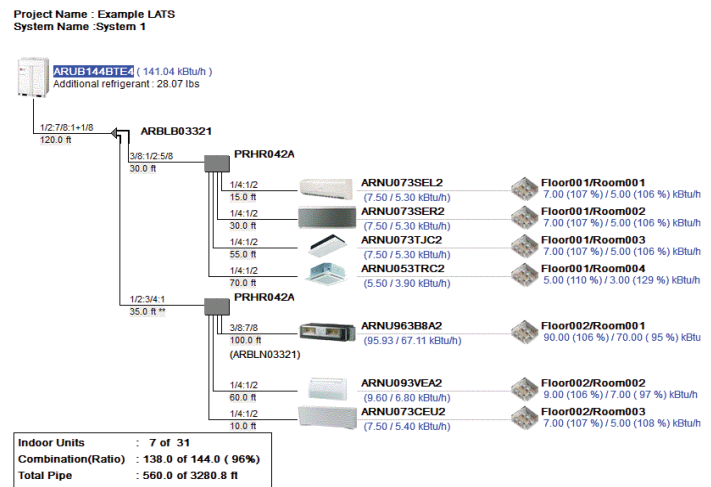

The contractor must mark any deviation from the design on the Shop Drawing, including as-built straight lines and elbows. This "Mark Up" drawing must be returned to the design engineer or Rep, who must input contractor changes into the LATS file. (Copy the original LATS software file, save and rename as a separate file, and modify all piping lengths by double-clicking on each length and editing information.) Like the shop drawing, the Auto Piping and System Check must also be run on this new "As Built" drawing. The design engineer or Rep must then provide the final As Built file to the contractor.

The Mark Up version must be compared to the As Built version for the following:

- Differences in pipe diameter(s). If incorrect diameters have been installed, the piping must be changed out. If pipe diameters have changed, check to see if Y-Branches will also need to be changed.
- Changes to outdoor unit and indoor unit capacities. Capacities changes may impact line length changes.
- Additional refrigerant charge quantity ("Trim Charge"). Trim charge will change if piping lengths and diameters change. The As Built version must reflect installed piping lengths to ensure correct trim charge.

All documents submitted by the contractor, as well as the Shop Drawing and the As Built Drawing files must be provided for commissioning purposes. Model and serial numbers for all system components must also be submitted. If the steps previously detailed are not followed, and all documents are not provided to the commissioning agent, the project runs the risk of not being commissioned and voiding any limited warranty LG offers on the equipment.





REFRIGERANT CHARGE WORKSHEET

Multi V 5 System R410A Refrigerant Charge Calculator (lbs.)

System Tag or ID:		Job Name: _____				
		Project Manager: _____			Date: _____	
Line #	Description	Chassis I.D.	Size	Quantity	CF (Ref.) ¹	Total (lbs.)
1	Linear feet of 1/4" liquid line tubing ²	—	—		0.015	
2	Linear feet of 3/8" liquid line tubing ²	—	—		0.041	
3	Linear feet of 1/2" liquid line tubing ²	—	—		0.079	
4	Linear feet of 5/8" liquid line tubing ²	—	—		0.116	
5	Linear feet of 3/4" liquid line tubing ²	—	—		0.179	
6	Linear feet of 7/8" liquid line tubing ²	—	—		0.238	
7	Linear feet of 1" liquid line tubing ²	—	—		0.323	
8	Standard + Art Cool Mirror	SJ, SK	5k to 15k		0.53	
9	Standard + Art Cool Mirror	SJ, SK	18k to 24k		0.62	
10	Standard	SV	30k to 36k		1.01	
11	Art Cool Gallery	SF	9k to 12k		0.22	
12	1-Way Cassette	TU	7k to 12k		0.44	
13	1-Way Cassette	TT	18k to 24k		0.64	
14	2-Way Cassette	TS	18k to 24k		0.75	
15	4-Way 2' x 2' Cassette	TR	5k to 7k		0.40	
16	4-Way 2' x 2' Cassette	TR	9k to 12k		0.55	
17	4-Way 2' x 2' Cassette	TQ	15k to 18k		0.71	
18	4-Way 3' x 3' Cassette	TN	7k to 24k		0.88	
19	4-Way 3' x 3' Cassette	TM	28k to 36k		1.08	
20	4-Way 3' x 3' Cassette	TM	42k to 48k		1.41	
21	Mid Static Ducted	M1	7k to 24k		0.57	
22	High Static Ducted	M2	7k to 24k		0.77	
23	Mid Static Ducted	M2	28k to 42k		1.15	
24	Mid / High Static Ducted	M3	28k to 54k		1.35	
25	High Static Ducted	B8	36k to 96k		2.20	
26	Low Static Ducted, Low Static Ducted Bottom Return	L1	5k to 9k		0.31	
27	Low Static Ducted, Low Static Ducted Bottom Return	L2	12k to 18k		0.42	
28	Low Static Ducted, Low Static Ducted Bottom Return	L3	21k to 24k		0.55	
29	Vertical / Horizontal Air Handling Unit	NJ	12k to 30k		1.04	
30	Vertical / Horizontal Air Handling Unit	NJ	36k		1.57	
31	Vertical / Horizontal Air Handling Unit	NK	42k to 54k		2.00	
32	Floor Standing	CE (U)	7k to 15k		0.37	
33	Floor Standing	CF (U)	18k to 24k		0.82	
34	HRU: PRHR022A/023A, 032A/033A, 042A/043A	—	—		1.1	
35	HRU: PRHR063A, 083A	—	—		2.2	
36	ADDITIONAL Refrigerant Charge Required (Sum of lines 1 – 35)					
37	Outdoor Unit Factory Refrigerant Charge	37A	ARUM072*TE5	72k	14.3	
		37B	ARUM096*TE5	96k	23.2	
		37C	ARUM121*TE5	121k	23.2	
		37D	ARUM144*TE5	144k	26.5	
		37E	ARUM168*TE5	168k	26.5	
		37F	ARUM192*TE5	192k	30.9	
		37G	ARUM216*TE5	216k	37.5	
		37H	ARUM241*TE5	241k	37.5	
38	Total ODU FACTORY Refrigerant Charge (Sum of factory refrigerant charges for all ODUs in the system, lines 37A -37H)					
39	TOTAL SYSTEM CHARGE Sum of Additional Refrigerant Charge Required (line 36) and Total ODU Factory Refrigerant Charge (line 38)					

Introduction

¹CF (Ref.) = Correction Factor for Refrigerant Charge. ²For refrigerant charge purposes, consider only the liquid line; ignore the vapor line(s).



REFRIGERANT CHARGE WORKSHEET



Water IV System R410A Refrigerant Charge Calculator (lbs.)

MULTI V Wall-Mounted Indoor Unit Engineering Manual

System Tag or ID:		Job Name: _____				
		Project Manager: _____			Date: _____	
Line #	Description	Chassis I.D.	Size	Quantity	CF (Ref.) ¹	Total (lbs.)
1	Linear feet of 1/4" liquid line tubing ²	—	—		0.015	
2	Linear feet of 3/8" liquid line tubing ²	—	—		0.041	
3	Linear feet of 1/2" liquid line tubing ²	—	—		0.079	
4	Linear feet of 5/8" liquid line tubing ²	—	—		0.116	
5	Linear feet of 3/4" liquid line tubing ²	—	—		0.179	
6	Linear feet of 7/8" liquid line tubing ²	—	—		0.238	
7	Linear feet of 1" liquid line tubing ²	—	—		0.323	
8	Standard + Art Cool Mirror	SJ, SK	5k to 15k		0.53	
9	Standard + Art Cool Mirror	SJ, SK	18k to 24k		0.62	
10	Standard	SV	30k to 36k		1.01	
11	Art Cool Gallery	SF	9k to 12k		0.22	
12	1-Way Cassette	TU	7k to 12k		0.44	
13	1-Way Cassette	TT	18k to 24k		0.64	
14	2-Way Cassette	TS	18k to 24k		0.75	
15	4-Way 2' x 2' Cassette	TR	5k to 7k		0.40	
16	4-Way 2' x 2' Cassette	TR	9k to 12k		0.55	
17	4-Way 2' x 2' Cassette	TO	15k to 18k		0.71	
18	4-Way 3' x 3' Cassette	TN	7k to 24k		0.88	
19	4-Way 3' x 3' Cassette	TM	28k to 36k		1.08	
20	4-Way 3' x 3' Cassette	TM	42k to 48k		1.41	
21	Mid Static Ducted	M1	7k to 24k		0.57	
22	High Static Ducted	M2	7k to 24k		0.77	
23	Mid Static Ducted	M2	28k to 42k		1.15	
24	Mid / High Static Ducted	M3	28k to 54k		1.35	
25	High Static Ducted	B8	36k to 96k		2.20	
26	Low Static Ducted, Low Static Ducted Bottom Return	L1	5k to 9k		0.31	
27	Low Static Ducted, Low Static Ducted Bottom Return	L2	12k to 18k		0.42	
28	Low Static Ducted, Low Static Ducted Bottom Return	L3	21k to 24k		0.55	
29	Vertical / Horizontal Air Handling Unit	NJ	12k to 30k		1.04	
30	Vertical / Horizontal Air Handling Unit	NJ	36k		1.57	
31	Vertical / Horizontal Air Handling Unit	NK	42k to 54k		2.00	
32	Floor Standing	CE (U)	7k to 15k		0.37	
33	Floor Standing	CF (U)	18k to 24k		0.82	
34	HRU: PRHR022A/023A, 032A/033A, 042A/043A	—	—		1.1	
35	HRU: PRHR063A, 083A	—	—		2.2	
36	ADDITIONAL Refrigerant Charge Required (Sum of lines 1 – 35)					
37	Water-Source Unit Factory Refrigerant Charge	ARW*072BAS4, ARW*096BAS4, ARW*121BAS4, ARW*144BAS4			10.42	
		ARW*072DAS4, ARW*096DAS4, ARW*121DAS4			10.42	
		ARW*144DAS4, ARW*192DAS4			11.66	
38	Total WSU FACTORY Refrigerant Charge (Sum of factory refrigerant charges for all WSUs in the system)					
39	TOTAL SYSTEM CHARGE					
	Sum of Additional Refrigerant Charge Required (line 36) and Total WSU Factory Refrigerant Charge (line 38)					

¹CF (Ref.) = Correction Factor for Refrigerant Charge. ²For refrigerant charge purposes, consider only the liquid line; ignore the vapor line(s).





REFRIGERANT CHARGE WORKSHEET

Multi V S System R410A Refrigerant Charge Calculator (lbs.)

System Tag or ID:		Job Name: _____				
		Project Manager: _____			Date: _____	
Line #	Description	Chassis I.D.	Size	Quantity	CF (Ref.) ¹	Total (lbs.)
1	Linear feet of 1/4" liquid line tubing ²	—	—		0.015	
2	Linear feet of 3/8" liquid line tubing ²	—	—		0.041	
3	Linear feet of 1/2" liquid line tubing ²	—	—		0.079	
4	Linear feet of 5/8" liquid line tubing ²	—	—		0.116	
5	Linear feet of 3/4" liquid line tubing ²	—	—		0.179	
6	Linear feet of 7/8" liquid line tubing ²	—	—		0.238	
7	Linear feet of 1" liquid line tubing ²	—	—		0.323	
8	Standard + Art Cool Mirror	SJ, SK	5k to 15k		0.53	
9	Standard + Art Cool Mirror	SJ, SK	18k to 24k		0.62	
10	Standard	SV	30k to 36k		1.01	
11	Art Cool Gallery	SF	9k to 12k		0.22	
12	1-Way Cassette	TU	7k to 12k		0.44	
13	1-Way Cassette	TT	18k to 24k		0.64	
14	2-Way Cassette	TS	18k to 24k		0.75	
15	4-Way 2' x 2' Cassette	TR	5k to 7k		0.40	
16	4-Way 2' x 2' Cassette	TR	9k to 12k		0.55	
17	4-Way 2' x 2' Cassette	TQ	15k to 18k		0.71	
18	4-Way 3' x 3' Cassette	TN	7k to 24k		0.88	
19	4-Way 3' x 3' Cassette	TM	28k to 36k		1.08	
20	4-Way 3' x 3' Cassette	TM	42k to 48k		1.41	
21	Mid Static Ducted	M1	7k to 24k		0.57	
22	High Static Ducted	M2	7k to 24k		0.77	
23	Mid Static Ducted	M2	28k to 42k		1.15	
24	Mid / High Static Ducted	M3	28k to 54k		1.35	
25	High Static Ducted	B8	36k to 96k		2.20	
26	Low Static Ducted, Low Static Ducted Bottom Return	L1	5k to 9k		0.31	
27	Low Static Ducted, Low Static Ducted Bottom Return	L2	12k to 18k		0.42	
28	Low Static Ducted, Low Static Ducted Bottom Return	L3	21k to 24k		0.55	
29	Vertical / Horizontal Air Handling Unit	NJ	12k to 30k		1.04	
30	Vertical / Horizontal Air Handling Unit	NJ	36k		1.57	
31	Vertical / Horizontal Air Handling Unit	NK	42k to 54k		2.00	
32	Floor Standing	CE (U)	7k to 15k		0.37	
33	Floor Standing	CF (U)	18k to 24k		0.82	
34	HRU: PRHR022A/023A, 032A/ 033A, 042A/ 043A	—	—		1.1	
35	HRU: PRHR063A, 083A	—	—		2.2	
36	ADDITIONAL Refrigerant Charge Required (Sum of lines 1 – 35)					
37	Total ODU FACTORY Refrigerant Charge (Choose One)	37A	ARUN024GSS4		0	
		37B	ARUN038GSS4		0	
		37C	ARUN048GSS4		0	
		37D	ARUN053GSS4		0	
		37E	ARUN060GSS4		0	
37F	ARUN060GSS4		0			
37G	ARUB060GSS4		0			
38	TOTAL SYSTEM CHARGE					
Sum of Additional Refrigerant Charge Required (line 36) and Total ODU Factory Refrigerant Charge (from lines 37A through 37G)						

Introduction

¹CF (Ref.) = Correction Factor for Refrigerant Charge. ²For refrigerant charge purposes, consider only the liquid line; ignore the vapor line(s).



ART COOL™ GALLERY

Mechanical Specifications on page 11

General Data on page 12

Electrical Data on page 13

External Dimensions on page 14

Electrical Wiring Diagram on page 15

Refrigerant Flow Diagrams on page 16

Acoustic Data on page 17

Air Velocity / Temperature Distribution on page 19

Capacity Tables on page 20



Casing

Units are designed to mount on a vertical surface and come complete with an installation mounting guide and a separate hanging bracket. The unit case is manufactured with coated metal. Cold surfaces are covered with a coated polystyrene insulating material.

Finish

The unit case has a light gray / silver matte finish. The front surface of the unit has a flat glass panel and frame that can accommodate a 20" x 20" photograph, picture or artwork.

Fan Assembly and Control

The indoor unit has a single, direct-drive, turbo fan. The fan wheel is made of high strength ABS HT-700 polymeric resin. The fan motor is a Brushless Digitally Controlled (BLDC) design with permanently lubricated and sealed ball bearings. The fan motor includes thermal, overcurrent and low RPM protection. The fan/motor assembly is mounted on vibration attenuating rubber grommets. The fan impeller is statically and dynamically balanced. The fan speed is controlled using a microprocessor-based, direct digital control algorithm that provides a high fan speed in cooling thermal ON and low fan speed in cooling thermal OFF, high fan speed in heating thermal ON and fan off in heating thermal OFF. The fan speeds can be field adjusted between low, medium, and high speeds. The fan speed algorithm provides a field selectable, fixed-speed or auto-speed setting that adjusts the fan speed to simulate natural airflow.

Air Filter

Return air is filtered with a removable, washable filter with anti-fungal treatment. Filter access is from the front of the unit without the use of tools.

Airflow Guide Vanes

The indoor unit is provided with motorized sweeping guide vanes that automatically change the direction of airflow from side-to-side and up-and-down.

Microprocessor Control

The unit is provided with an integrated microprocessor controller capable of performing functions necessary to operate the system without the use of a wall-mounted controller. A temperature thermistor is factory mounted in the return air stream. All unit operation parameters, excluding the operating schedule, are stored in non-volatile memory resident on the unit microprocessor. Operating schedules are stored in select models of the optional, wall-mounted, local or central controllers. The field-supplied communication cable between the indoor unit(s) and outdoor unit is to be a minimum of 18 AWG, 2 conductor, stranded, and shielded cable (RS-485), terminated via screw terminals on the control boards. The microprocessor control provides the following functions: auto addressing, self-diagnostics, auto restart following power restoration, test run, and will operate the indoor unit using one of five operation modes:

- Auto Changeover (Heat Recovery only)
- Heating
- Cooling
- Dry
- Fan Only

For Heat Recovery systems the Auto Changeover setting automatically switches control of the indoor unit between Cooling and Heating modes based on space temperature conditions. For Heat Pump

systems, heated or cooled air delivery is dependent upon outdoor unit operating mode. In Heating mode, the microprocessor control will activate indoor unit operation when the indoor room temperature falls below set-point temperature. At which point, a signal is sent to the outdoor unit to begin the heating cycle. The indoor unit fan operation is delayed until coil pipe temperature reaches 76°F. Significant airflow is generated when pipe temperature reaches 80°F. A field-selectable option maintains fan operation for 30 minutes following cooling cycle operations. The unit is equipped with an infrared receiver designed to communicate with an LG wireless remote controller. In lieu of wireless remote or factory return air thermistor, screw terminals on the microprocessor circuit board accommodate various models of wall-mounted local controllers. The unit microprocessor is capable of accepting space temperature readings concurrently or individually from either:

- Wall-mounted wired controller(s), or
- Factory-mounted return air thermistor

A single indoor unit has the capability of being controlled by up to two local wired controllers. The microprocessor controls space temperature using the value provided by the temperature sensor sensing a space temperature that is farthest away from the temperature set-point. The microprocessor control provides a cooling or heating mode test cycle that operates the unit for eighteen (18) minutes without regard to the space temperature. If the system is provided with an optional wall-mounted local or central controller, displayed diagnostic codes are specific, alpha-numeric, and provide the service technician with a reason for the code displayed.

Handling Condensate

The unit is designed for gravity draining of condensate. LG provides a factory insulated flexible drain hose. If condensate lift/pumps are needed for the application, they are to be field provided.

Condensate Drain Pan

The condensate drain pan is constructed of expandable polystyrene resin (EPS).

Coil

The indoor unit coil is constructed with grooved design copper tubes with slit coil fins, two (2) rows, eighteen (18) fins per inch.

Controls Features

- Auto changeover (Heat Recovery only)
- Auto operation
- Auto clean (coil dry; requires wireless controller)
- External on/off control
- Dual thermistor control
- Dual setpoint control*
- Filter life display*
- Group control
- Forced operation
- Hot start
- Self diagnostics
- Timer (on/off)
- Weekly schedule
- Auto direction/swing (up/down)
- Fan speed control
- Jet cool (fast cooling)
- Wi-Fi
- Auto Fan
- Leak Detection

**To enable Generation 4 features, outdoor unit DIP Switch No. 3 must be set to ON. Please refer to the Multi V 5, Multi V IV, Multi V Water IV, Multi V S Engineering Manual for additional information.*



ART COOL GALLERY



General Data

Table 1: Art Cool Gallery (SF Frames) Indoor Unit General Data.

Model No.	ARNU093SFA4	ARNU123SFA4
<i>Cooling Mode Performance</i>		
Capacity (Btu/h)	9,600	12,300
Max. Power Input ¹ (W)	35	35
H / M / L Power Input at Factory Default (W)	28 / 16 / 10	32 / 20 / 12
<i>Heating Mode Performance</i>		
Capacity (Btu/h)	10,900	13,600
Max. Power Input ¹ (W)	35	35
H / M / L Power Input at Factory Default (W)	28 / 16 / 10	32 / 20 / 12
<i>Entering Mixed Air</i>		
Cooling Max (°F WB) ²	76	76
Heating Min (°F DB) ²	59	59
<i>Unit Data</i>		
Refrigerant Type ³	R410A	R410A
Refrigerant Control	EEV	EEV
Sound Pressure ⁴ dB(A) (H / M / L)	38 / 32 / 27	44 / 38 / 32
Net Unit Weight (lbs.)	33.1	33.1
Shipping Weight (lbs.)	38.1	38.1
Communication Cable ⁵ (No. x AWG)	2 x 18	2 x 18
<i>Fan</i>		
Type	Turbo Fan	Turbo Fan
Quantity	1	1
Motor/Drive	Brushless Digitally Controlled / Direct	
Airflow Rate H / M / L (CFM)	286 / 222 / 148	328 / 272 / 212
<i>Piping</i>		
Liquid Line (in., O.D.)	1/4 Flare	1/4 Flare
Vapor Line (in., O.D.)	1/2 Flare	1/2 Flare
Condensate Line (in., I.D.)	5/8	5/8

EEV: Electronic Expansion Valve

Power wiring is field supplied and must comply with the applicable local and national codes.

This unit comes with a dry nitrogen charge.

All capacities are net with a combination ratio between 95-105%.

Rated capacity is certified under AHRI Standard 1230. Ratings are subject to change without notice. Current certified ratings are available at www.ahridirectory.org.

¹Max. power input is rated at maximum setting value.

²Low ambient performance with LGRED[®] heat technology is included in Multi V 5 Air

Source Units produced after February 2019.

³Take appropriate actions at the end of HVAC equipment life to recover, recycle, reclaim or destroy R410A refrigerant according to applicable regulations (40 CFR Part 82, Subpart F) under section 608 of CAA.

⁴Sound Pressure levels are tested in an anechoic chamber under ISO Standard 3745.

⁵All communication cable to be minimum 18 AWG, 2-conductor, twisted, stranded, shielded and must comply with applicable local and national codes. Ensure the communication cable is properly grounded at the main outdoor unit only. Ⓞ Do not ground the ODU-IDU communication cable at any other point.

Table 2: Art Cool Gallery Wall-Mounted Indoor Unit Electrical Data.

Model Number	Voltage Range	MCA	MOP	Rated Amps (A)	Power Supply			Power Input (W)		
					Hz	Volts	Phase	Max. Cooling	Max. Heating	H / M / L at Factory Default
<i>SF Frames</i>										
ARNU093SFA4	187-253	0.4	15	0.3	60	208-230	1	35	35	28 / 16 / 10
ARNU123SFA4		0.4	15	0.3				35	35	32 / 20 / 12

MCA : Minimum Circuit Ampacity.

MOP : Maximum Overcurrent Protection.

Units are suitable for use on an electrical system where voltage supplied to unit terminals is within the listed range limits.

Select wire size based on the larger MCA value.

Instead of fuse, use the circuit breaker.

Max. power input is rated at maximum setting value.

ART COOL GALLERY



External Dimensions

SF Frame

Figure 3: ARNU093SFA4 and ARNU123SFA4 Dimensions.

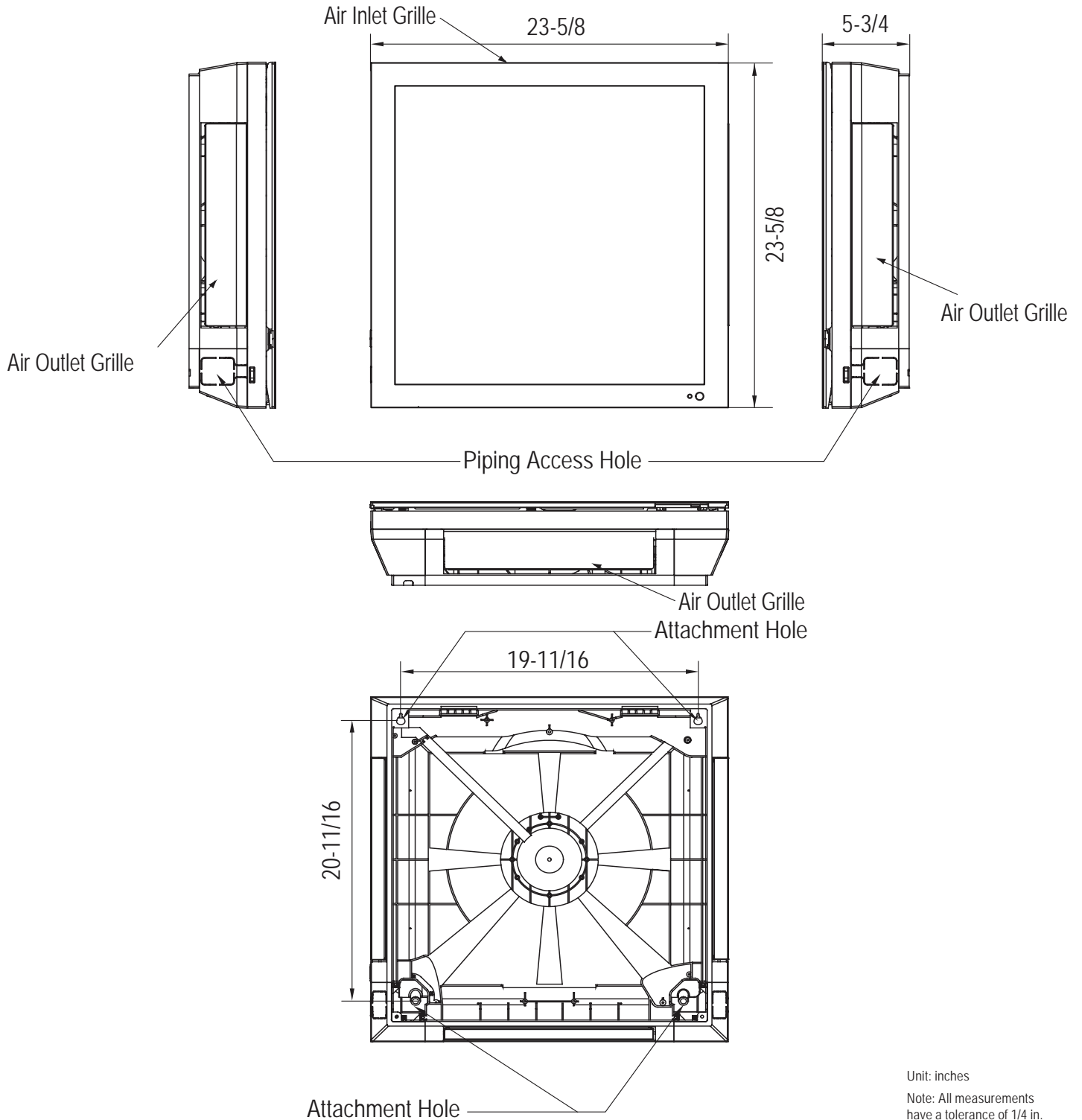

Unit: inches
Note: All measurements have a tolerance of 1/4 in.

Figure 4: ARNU093SFA4 and ARNU123SFA4 Wiring Diagram.

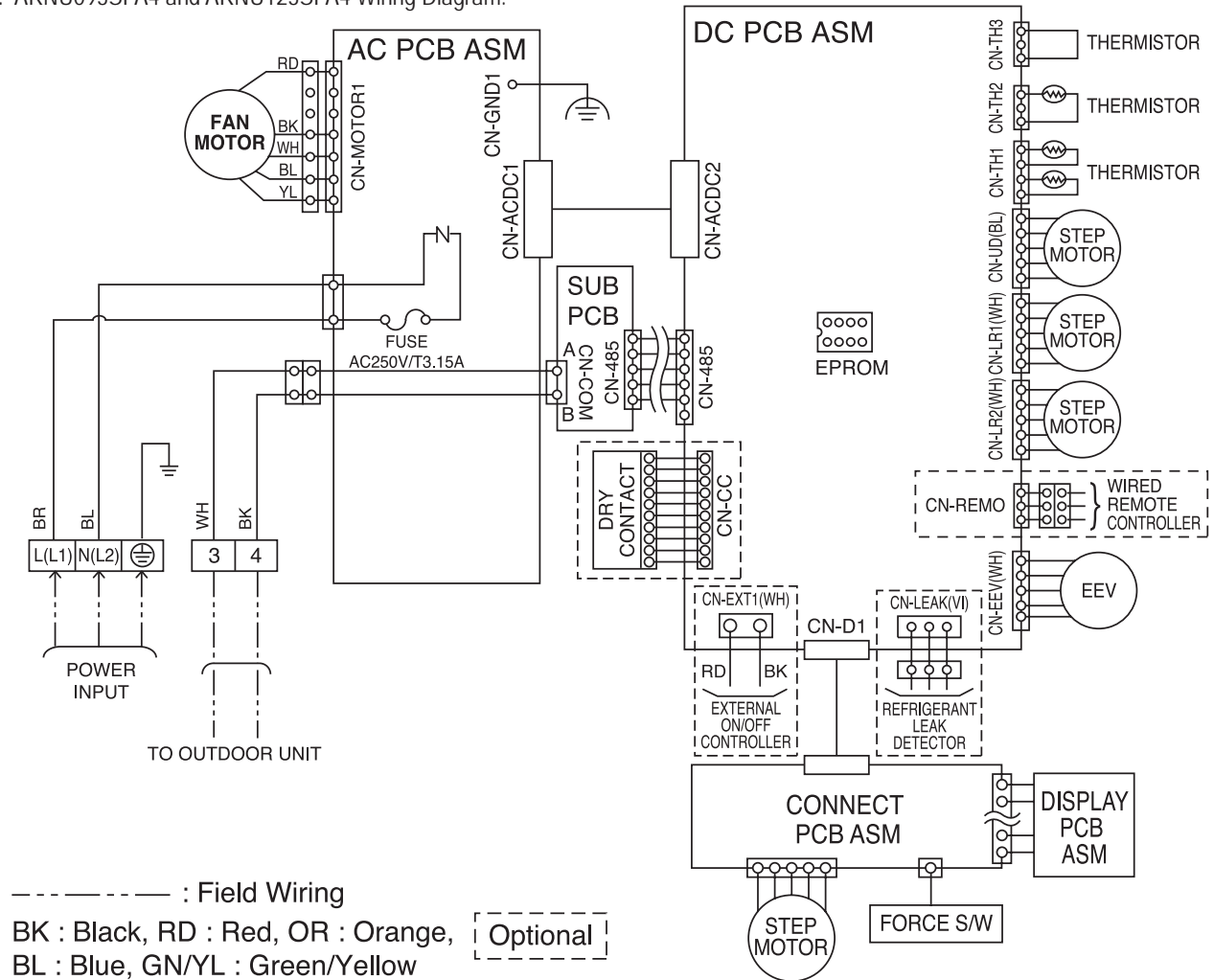

Table 3: SF Frame Wiring Diagram Legend.

PCB Connection	Purpose	Function
CN-TH3	Pipe out thermistor	Pipe out thermistor connection
CN-TH2	Pipe in thermistor	Pipe in thermistor connection
CN-TH1	Return air thermistor	Return air thermistor connection
CN-UD	Step motor	Step motor output
CN-LR1	Step motor	Step motor output
CN-LR2	Step motor	Step motor output
CN-REMO	Wired remote controller	Wired remote controller connection
CN-EEV	EEV output	EEV control output
CN-EXT1	External on/off controller	External on/off controller connection
CN-CC	Dry contact	Dry contact connection
CN-485	Communication	Connection between indoor and outdoor units

*To enable Generation 4 features, outdoor unit DIP switch no. 3 must be set to ON. Please refer to the Multi V 5, Multi V IV, Multi V Water IV, Multi V S Engineering Manual for additional information.

Refrigerant Flow Diagram SF Frame

Figure 5: SF Frame Piping Diagram.

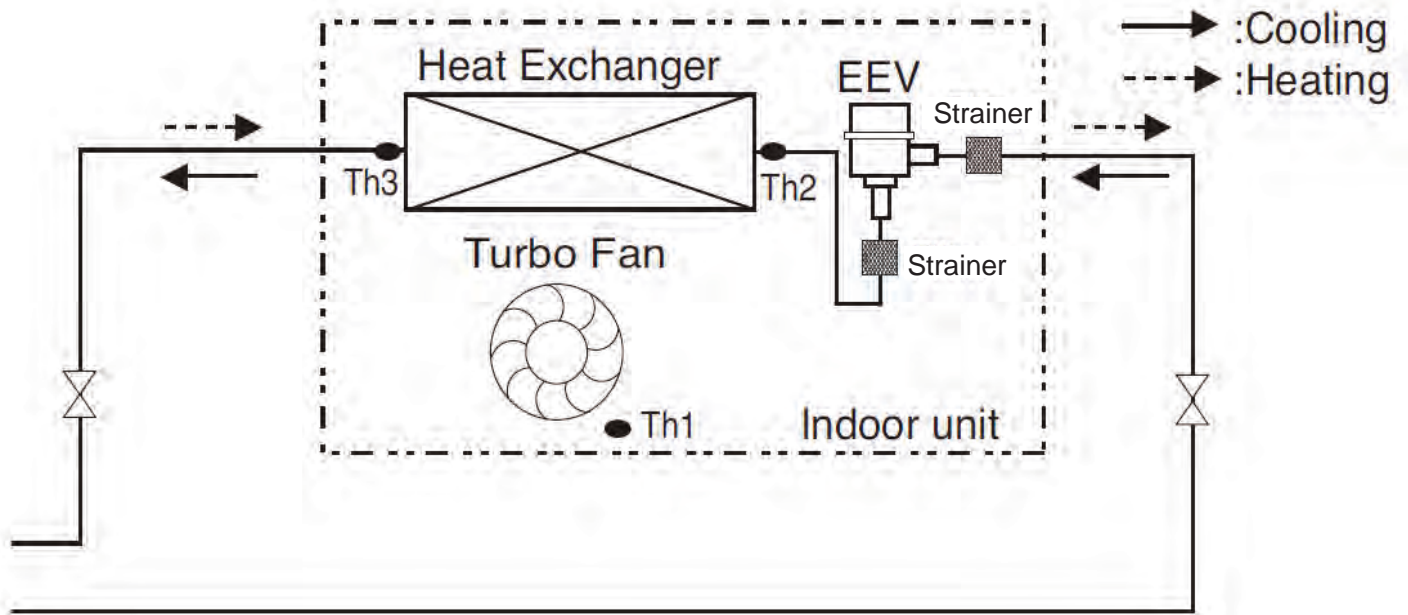

Table 4: SF Frame Refrigerant Pipe Connection Port Diameters.

Model	Liquid (inch)	Vapor (inch)
<i>SF Frames</i>		
ARNU093SFA4	1/4 Flare	1/2 Flare
ARNU123SFA4	1/4 Flare	1/2 Flare

Table 5: SF Frame Thermistors.

Thermistor	Description
TH1	Return air thermistor
TH2	Pipe in thermistor
TH3	Pipe out thermistor

Figure 6: Sound Pressure Measurement Location.

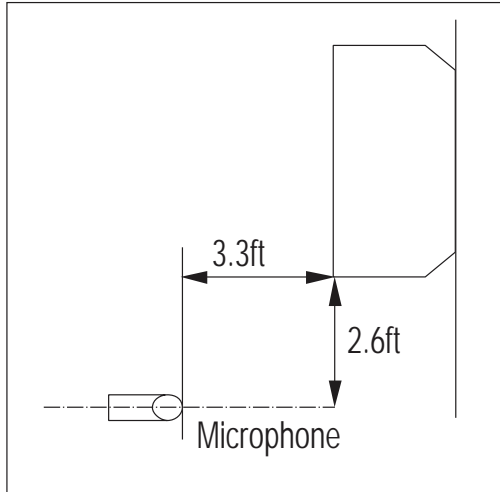

- Measurements are taken 3.3 ft away from the front of the unit.
 - Sound pressure levels are measured in dB(A) with a tolerance of ± 3 .
 - Sound pressure levels are tested in an anechoic chamber under ISO Standard 3745.
- Operating Conditions:
- Power source: 220V/60 Hz
 - Sound level will vary depending on a range of factors including the construction (acoustic absorption coefficient) of a particular room in which the unit was installed.

Table 6: Art Cool Gallery Indoor Unit Sound Pressure Levels.

Model	Sound Pressure Levels dB(A)		
	High Fan Speed	Medium Fan Speed	Low Fan Speed
SF Frames			
ARNU093SFA4	38.0	32.0	27.0
ARNU123SFA4	44.0	38.0	32.0

Figure 7: ARNU093SFA4 and ARNU123SFA4 Sound Pressure Level Diagrams.

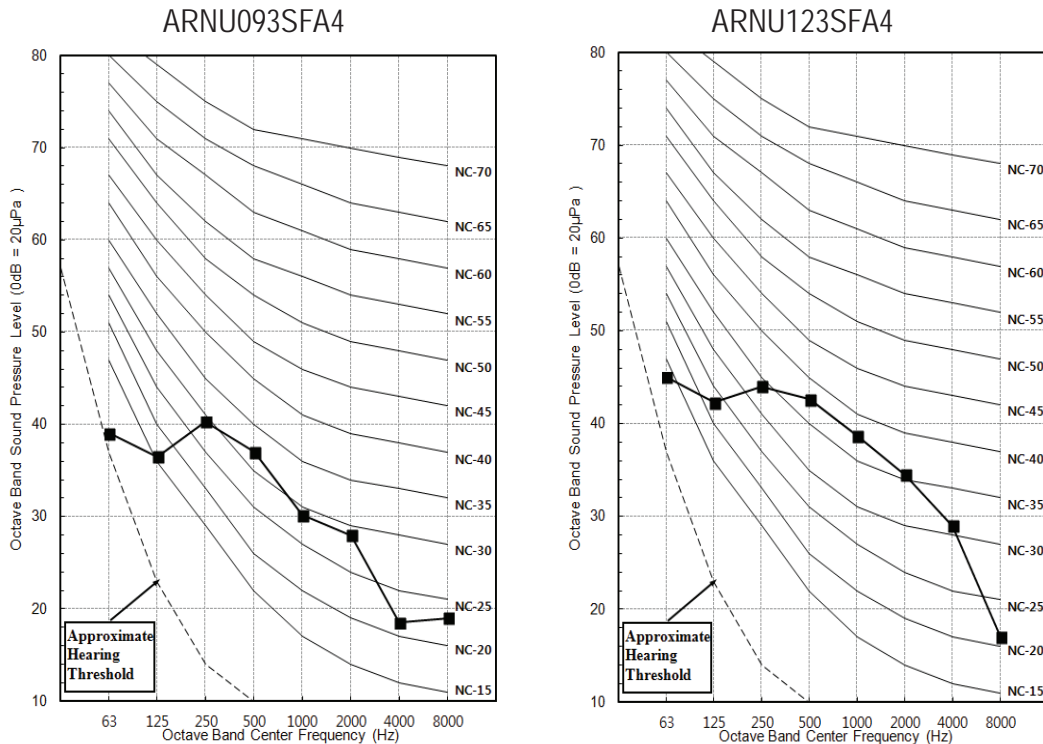

ART COOL GALLERY



Acoustic Data

Sound Power Levels

Table 7: Art Cool Gallery Indoor Unit Sound Power Levels.

Model	Sound Power Levels dB(A)
	High Fan Speed
<i>SF Frames</i>	
ARNU093SFA4	48.0
ARNU123SFA4	54.0

- Data is valid under diffuse field conditions.
- Data is valid under nominal operating conditions.
- Sound power level is measured using rated conditions, and tested in a reverberation room per ISO 3741 standards.
- Sound level will vary depending on a range of factors such as construction (acoustic absorption coefficient) of particular area in which the equipment is installed.
- Reference acoustic intensity: 0dB = 10E-6μW/m²

Figure 8: ARNU093SFA4 and ARNU123SFA4 Sound Power Level Diagrams.

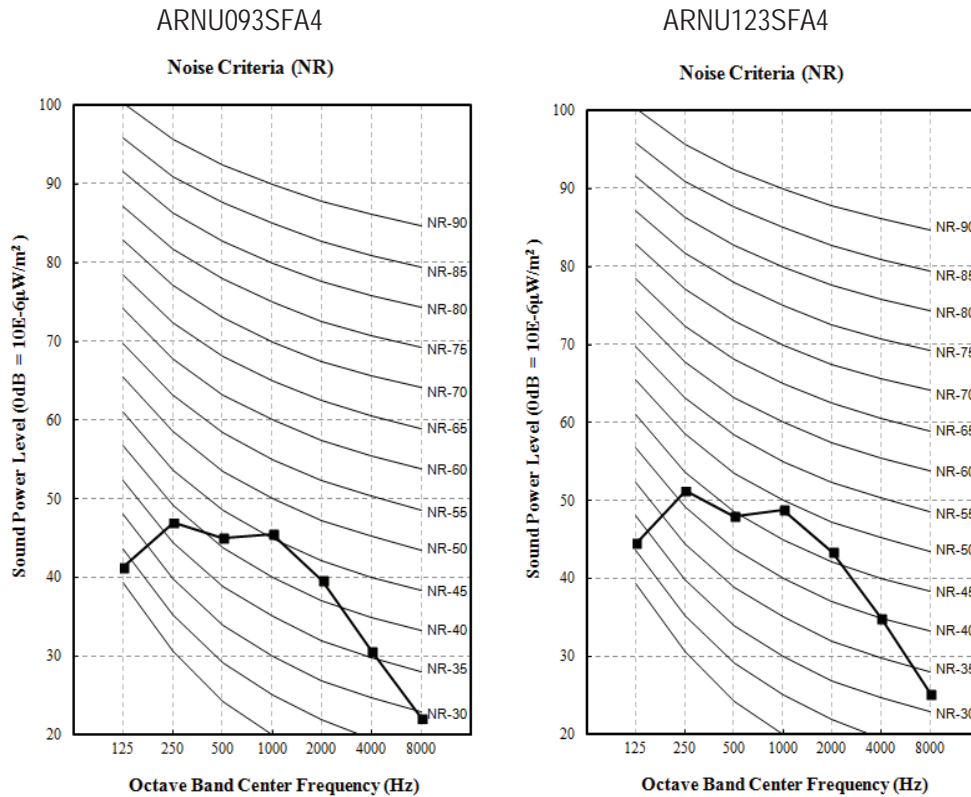

Figure 9: ARNU093SFA4.

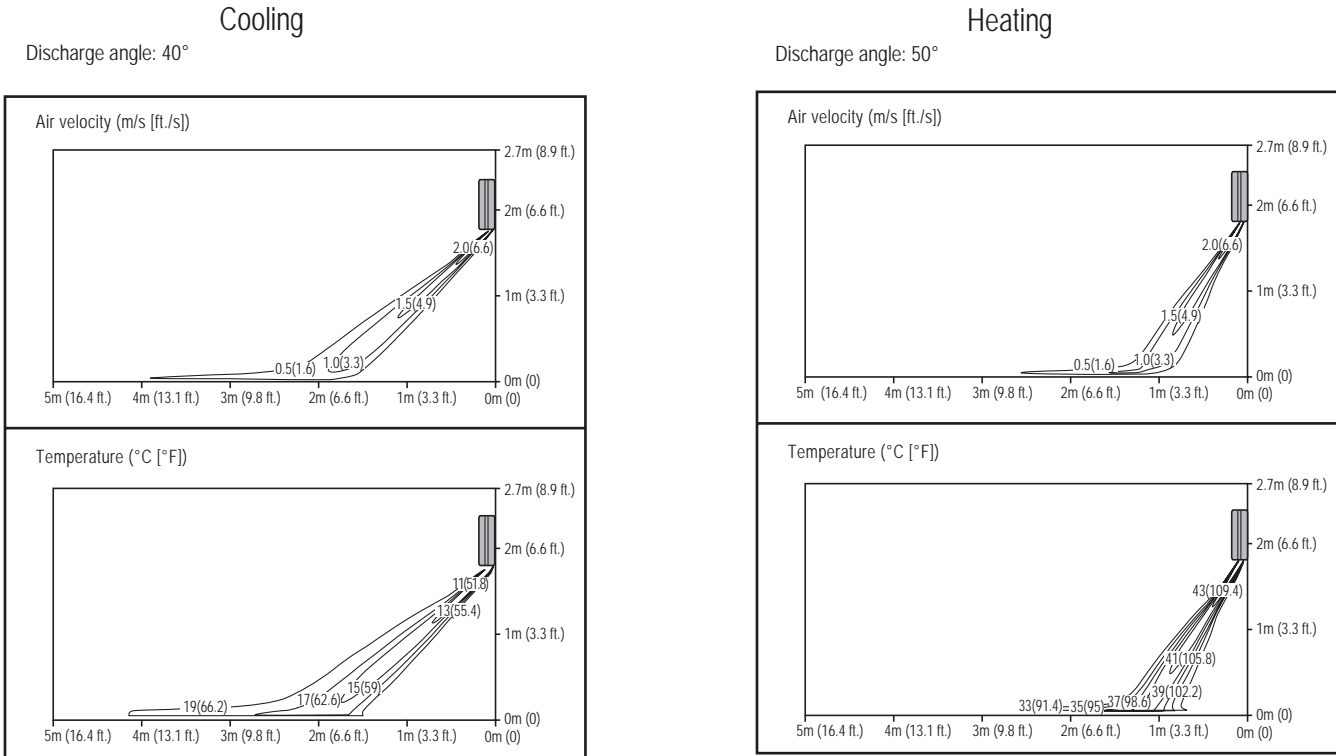
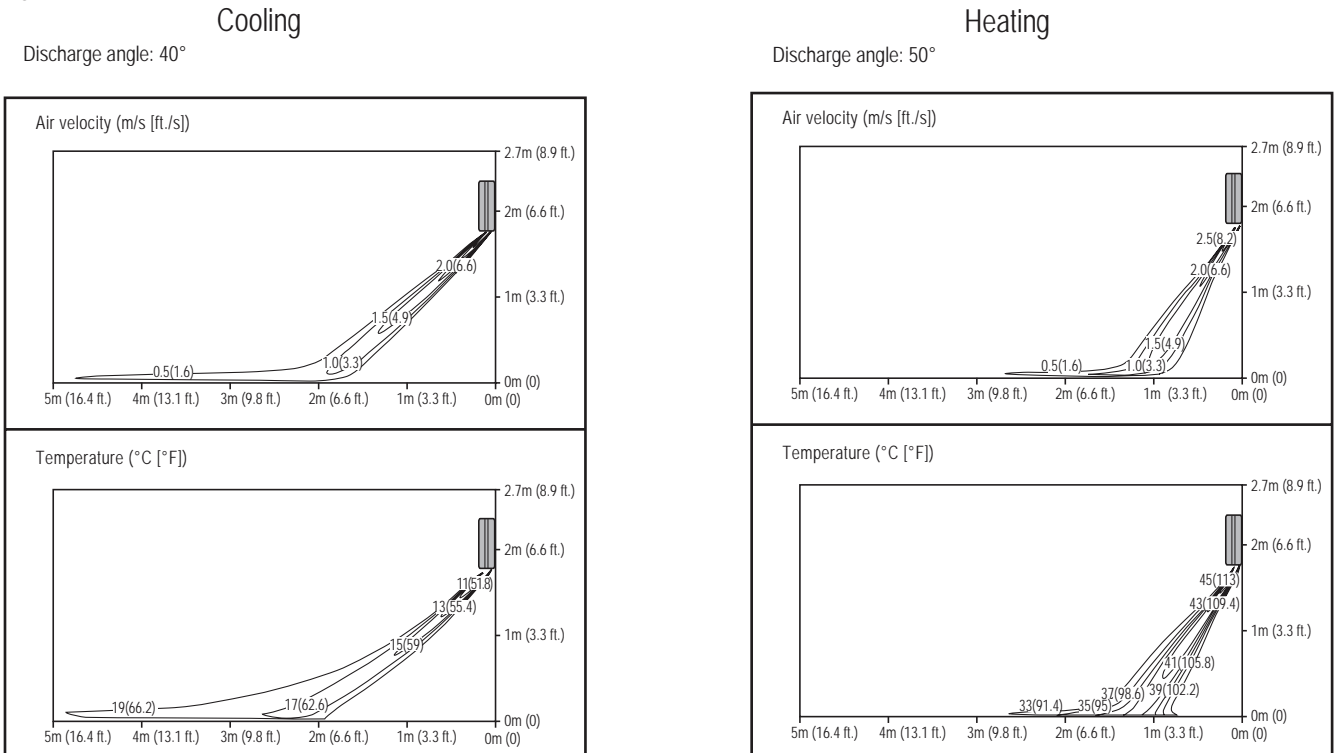

Figure 10: ARNU123SFA4.



ART COOL GALLERY



Cooling Capacity Tables

ARNU093SFA4

Table 8: ARNU093SFA4 Cooling Capacity Table.

Model No. / Capacity Index	Outdoor Air Temp. (°F DB)	Indoor Air Temperature (°F DB / WB)													
		68 / 57		73 / 61		79 / 64		80 / 67		85 / 70		88 / 73		91 / 76	
		TC	SHC	TC	SHC	TC	SHC	TC	SHC	TC	SHC	TC	SHC	TC	SHC
ARNU093SFA4/ 9.6	-9.9	6.3	5.3	7.7	6.1	8.6	6.5	9.6	6.9	10.8	7.4	11.4	7.3	12.4	7.3
	-5	6.3	5.3	7.7	6.1	8.6	6.5	9.6	6.9	10.8	7.4	11.4	7.3	12.4	7.3
	0	6.3	5.3	7.7	6.1	8.6	6.5	9.6	6.9	10.8	7.4	11.4	7.3	12.4	7.3
	5	6.3	5.3	7.7	6.1	8.6	6.5	9.6	6.9	10.8	7.4	11.4	7.3	12.4	7.3
	10	6.3	5.3	7.7	6.1	8.6	6.5	9.6	6.9	10.8	7.4	11.4	7.3	12.4	7.3
	14	6.3	5.3	7.7	6.1	8.6	6.5	9.6	6.9	10.8	7.4	11.4	7.3	12.4	7.3
	20	6.3	5.3	7.7	6.1	8.6	6.5	9.6	6.9	10.8	7.4	11.4	7.3	12.4	7.3
	23	6.3	5.3	7.7	6.1	8.6	6.5	9.6	6.9	10.8	7.4	11.4	7.3	12.4	7.3
	25	6.3	5.3	7.7	6.1	8.6	6.5	9.6	6.9	10.8	7.4	11.4	7.3	12.4	7.3
	30	6.3	5.3	7.7	6.1	8.6	6.5	9.6	6.9	10.8	7.4	11.4	7.3	12.4	7.3
	35	6.3	5.3	7.7	6.1	8.6	6.5	9.6	6.9	10.8	7.4	11.4	7.3	12.4	7.3
	40	6.3	5.3	7.7	6.1	8.6	6.5	9.6	6.9	10.8	7.4	11.4	7.3	12.4	7.3
	45	6.3	5.3	7.7	6.1	8.6	6.5	9.6	6.9	10.8	7.4	11.4	7.3	12.4	7.3
	50	6.3	5.3	7.7	6.1	8.6	6.5	9.6	6.9	10.8	7.4	11.4	7.3	12.4	7.3
	55	6.3	5.3	7.7	6.1	8.6	6.5	9.6	6.9	10.8	7.4	11.4	7.3	12.4	7.3
	60	6.3	5.3	7.7	6.1	8.6	6.5	9.6	6.9	10.8	7.4	11.4	7.3	12.3	7.3
	65	6.3	5.3	7.7	6.1	8.6	6.5	9.6	6.9	10.8	7.4	11.4	7.3	12.1	7.2
	70	6.3	5.3	7.7	6.1	8.6	6.5	9.6	6.9	10.8	7.4	11.4	7.3	11.9	7.1
	75	6.3	5.3	7.7	6.1	8.6	6.5	9.6	6.9	10.8	7.4	11.4	7.3	11.6	6.9
	80	6.3	5.3	7.7	6.1	8.6	6.5	9.6	6.9	10.8	7.4	11.1	7.3	11.3	6.9
85	6.3	5.3	7.7	6.1	8.6	6.5	9.6	6.9	10.6	7.3	10.8	7.0	11.0	6.6	
90	6.3	5.3	7.7	6.1	8.6	6.5	9.6	6.9	10.5	7.2	10.6	6.9	10.8	6.5	
95	6.3	5.3	7.7	6.1	8.6	6.5	9.6	6.9	10.3	7.2	10.5	6.8	10.6	6.4	
100	6.3	5.3	7.7	6.1	8.6	6.5	9.6	6.9	10.1	7.1	10.3	6.7	10.5	6.4	
105	6.3	5.3	7.3	5.8	8.2	6.2	9.2	6.6	9.6	6.6	9.9	6.5	10.2	6.2	
110	6.2	5.1	6.9	5.5	7.7	5.8	8.6	6.2	9.0	6.2	9.4	6.2	9.8	6.0	
115	6.0	5.0	6.6	5.2	7.2	5.4	8.1	5.9	8.5	5.9	8.9	5.9	9.4	5.8	
118	5.9	4.8	6.2	4.9	6.9	5.1	7.8	5.6	8.1	5.6	8.5	5.6	9.0	5.6	
122	5.7	4.7	5.9	4.7	6.5	4.8	7.4	5.3	7.7	5.3	8.1	5.3	8.7	5.3	

TC: Total Capacity (MBh); SHC: Sensible Heat Capacity (MBh).
 Cooling range with the Low Ambient Baffle Kit (sold separately) installed on the outdoor unit(s) is -9.9°F to +122°F, and is achieved only when all indoor units are operating in cooling mode. Does not impact heat recovery system synchronous operating range. The System Combination Ratio must be between 50–130%.

Rated capacity is certified under AHRI Standard 1230. Ratings are subject to change without notice.
 Current certified ratings are available at www.ahridirectory.org.
 For outdoor unit performance data, see the respective outdoor unit performance data manuals on <https://lghvac.com/commercial>.

Note:

Low ambient performance with LGRED° heat technology is included in Multi V 5 Air Source Units produced after February 2019.



Table 9: ARNU123SFA4 Cooling Capacity Table.

Model No./ Capacity Index	Outdoor Air Temp. (°F DB)	Indoor Air Temperature (°F DB / WB)													
		68 / 57		73 / 61		79 / 64		80 / 67		85 / 70		88 / 73		91 / 76	
		TC	SHC	TC	SHC	TC	SHC	TC	SHC	TC	SHC	TC	SHC	TC	SHC
ARNU123SFA4/ 12.3	-9.9	8.1	6.8	9.8	7.9	11.1	8.4	12.3	8.9	13.8	9.6	14.7	9.5	15.9	9.5
	-5	8.1	6.8	9.8	7.9	11.1	8.4	12.3	8.9	13.8	9.6	14.7	9.5	15.9	9.5
	0	8.1	6.8	9.8	7.9	11.1	8.4	12.3	8.9	13.8	9.6	14.7	9.5	15.9	9.5
	5	8.1	6.8	9.8	7.9	11.1	8.4	12.3	8.9	13.8	9.6	14.7	9.5	15.9	9.5
	10	8.1	6.8	9.8	7.9	11.1	8.4	12.3	8.9	13.8	9.6	14.7	9.5	15.9	9.5
	14	8.1	6.8	9.8	7.9	11.1	8.4	12.3	8.9	13.8	9.6	14.7	9.5	15.9	9.5
	20	8.1	6.8	9.8	7.9	11.1	8.4	12.3	8.9	13.8	9.6	14.7	9.5	15.9	9.5
	23	8.1	6.8	9.8	7.9	11.1	8.4	12.3	8.9	13.8	9.6	14.7	9.5	15.9	9.5
	25	8.1	6.8	9.8	7.9	11.1	8.4	12.3	8.9	13.8	9.6	14.7	9.5	15.9	9.5
	30	8.1	6.8	9.8	7.9	11.1	8.4	12.3	8.9	13.8	9.6	14.7	9.5	15.9	9.5
	35	8.1	6.8	9.8	7.9	11.1	8.4	12.3	8.9	13.8	9.6	14.7	9.5	15.9	9.5
	40	8.1	6.8	9.8	7.9	11.1	8.4	12.3	8.9	13.8	9.6	14.7	9.5	15.9	9.5
	45	8.1	6.8	9.8	7.9	11.1	8.4	12.3	8.9	13.8	9.6	14.7	9.5	15.9	9.5
	50	8.1	6.8	9.8	7.9	11.1	8.4	12.3	8.9	13.8	9.6	14.7	9.5	15.9	9.5
	55	8.1	6.8	9.8	7.9	11.1	8.4	12.3	8.9	13.8	9.6	14.7	9.5	15.9	9.5
	60	8.1	6.8	9.8	7.9	11.1	8.4	12.3	8.9	13.8	9.6	14.7	9.5	15.7	9.4
	65	8.1	6.8	9.8	7.9	11.1	8.4	12.3	8.9	13.8	9.6	14.7	9.5	15.5	9.3
	70	8.1	6.8	9.8	7.9	11.1	8.4	12.3	8.9	13.8	9.6	14.7	9.5	15.3	9.1
	75	8.1	6.8	9.8	7.9	11.1	8.4	12.3	8.9	13.8	9.6	14.7	9.5	14.9	8.9
	80	8.1	6.8	9.8	7.9	11.1	8.4	12.3	8.9	13.8	9.6	14.2	9.4	14.5	8.9
85	8.1	6.8	9.8	7.9	11.1	8.4	12.3	8.9	13.6	9.5	13.8	9.0	14.0	8.5	
90	8.1	6.8	9.8	7.9	11.1	8.4	12.3	8.9	13.4	9.3	13.5	8.9	13.8	8.4	
95	8.1	6.8	9.8	7.9	11.1	8.4	12.3	8.9	13.2	9.3	13.4	8.8	13.6	8.3	
100	8.1	6.8	9.8	7.9	11.1	8.4	12.3	8.9	12.9	9.1	13.2	8.7	13.4	8.3	
105	8.1	6.8	9.3	7.5	10.6	8.0	11.8	8.5	12.3	8.5	12.7	8.4	13.0	8.1	
110	7.9	6.6	8.9	7.1	9.8	7.5	11.1	8.0	11.6	8.0	12.0	8.0	12.6	7.8	
115	7.7	6.4	8.4	6.7	9.2	7.0	10.4	7.6	10.9	7.6	11.4	7.6	12.1	7.5	
118	7.5	6.2	8.0	6.4	8.8	6.6	10.0	7.2	10.4	7.2	10.9	7.2	11.6	7.2	
122	7.3	6.0	7.6	6.0	8.3	6.2	9.4	6.9	9.8	6.9	10.3	6.9	11.1	6.9	

TC: Total Capacity (MBh); SHC: Sensible Heat Capacity (MBh).
 Cooling range with the Low Ambient Baffle Kit (sold separately) installed on the outdoor unit(s) is -9.9°F to +122°F, and is achieved only when all indoor units are operating in cooling mode. Does not impact heat recovery system synchronous operating range.
 The System Combination Ratio must be between 50–130%.

Rated capacity is certified under AHRI Standard 1230. Ratings are subject to change without notice.
 Current certified ratings are available at www.ahridirectory.org.
 For outdoor unit performance data, see the respective outdoor unit performance data manuals on <https://lghvac.com/commercial>.

Note:

Low ambient performance with LGRED° heat technology is included in Multi V 5 Air Source Units produced after February 2019.

ART COOL GALLERY



Heating Capacity Tables

ARNU093SFA4

Table 10: ARNU093SFA4 Heating Capacity Table.

Model No./ Capacity Index	Outdoor Air Temp.		Indoor Air Temperature (°F DB)							
			59	61	64	67	70	73	76	80
	°F DB	°F WB	TC	TC	TC	TC	TC	TC	TC	TC
		MBh	MBh	MBh	MBh	MBh	MBh	MBh	MBh	MBh
ARNU093SFA4/ 9.6	-21.6	-22.0	5.5	5.5	5.5	5.5	5.5	5.5	5.5	5.5
	-17.1	-17.5	6.2	6.2	6.2	6.2	6.1	6.1	6.1	6.1
	-12.6	-13	6.9	6.9	6.9	6.9	6.8	6.8	6.8	6.8
	-7	-7.6	7.1	7.1	7.1	7.1	7.0	7.0	7.0	7.0
	-4	-4.4	7.3	7.3	7.3	7.3	7.2	7.2	7.2	7.2
	0	-0.4	7.5	7.5	7.5	7.5	7.5	7.4	7.4	7.4
	5	4.5	8.5	8.4	8.3	8.3	8.3	8.3	8.3	8.3
	10	9	8.8	8.8	8.8	8.7	8.7	8.7	8.7	8.7
	15	14	9.4	9.4	9.4	9.4	9.4	9.4	9.3	9.2
	20	19	9.9	9.9	9.9	9.9	9.7	9.7	9.5	9.4
	25	23	10.4	10.4	10.4	10.4	10.4	10.1	10.0	9.5
	30	28	10.6	10.6	10.6	10.6	10.6	10.4	10.0	9.5
	35	32	10.9	10.9	10.9	10.9	10.8	10.6	10.0	9.5
	40	36	11.3	11.3	11.3	11.3	10.9	10.6	10.0	9.5
	45	41	11.8	11.8	11.8	11.5	10.9	10.6	10.0	9.5
	47	43	12.2	12.1	12.0	11.5	10.9	10.6	10.0	9.5
50	46	13.1	12.5	12.0	11.5	10.9	10.6	10.0	9.5	
55	51	13.4	12.6	12.0	11.5	10.9	10.6	10.0	9.5	
60	56	13.4	12.6	12.0	11.5	10.9	10.6	10.0	9.5	

TC: Total Capacity (MBh).

The System Combination Ratio must be between 50–130%.

Rated capacity is certified under AHRI Standard 1230. Ratings are subject to change without notice.

Current certified ratings are available at www.ahridirectory.org.

For outdoor unit performance data, see the respective outdoor unit performance data manuals on <https://lghvac.com/commercial>.

Note:

Low ambient performance with LGRED® heat technology is included in Multi V 5 Air Source Units produced after February 2019.

Table 11: ARNU123SFA4 Heating Capacity Table.

Model No./ Capacity Index	Outdoor Air Temp.		Indoor Air Temperature (°F DB)							
			59	61	64	67	70	73	76	80
	°F DB	°F WB	TC	TC	TC	TC	TC	TC	TC	TC
		MBh	MBh	MBh	MBh	MBh	MBh	MBh	MBh	MBh
ARNU123SFA4/ 12.3	-21.6	-22.0	6.9	6.9	6.9	6.9	6.8	6.8	6.8	6.8
	-17.1	-17.5	7.7	7.7	7.7	7.7	7.6	7.6	7.6	7.6
	-12.6	-13	8.6	8.6	8.6	8.6	8.5	8.5	8.5	8.5
	-7	-7.6	8.8	8.8	8.8	8.8	8.7	8.7	8.7	8.7
	-4	-4.4	9.1	9.1	9.1	9.1	9.0	9.0	9.0	9.0
	0	-0.4	9.4	9.4	9.4	9.4	9.4	9.3	9.3	9.3
	5	4.5	10.6	10.5	10.3	10.3	10.3	10.3	10.3	10.3
	10	9	11.0	11.0	11.0	10.9	10.9	10.9	10.9	10.9
	15	14	11.7	11.7	11.7	11.7	11.7	11.7	11.6	11.4
	20	19	12.4	12.4	12.4	12.4	12.1	12.1	11.9	11.8
	25	23	12.9	12.9	12.9	12.9	12.9	12.7	12.5	11.9
	30	28	13.2	13.2	13.2	13.2	13.2	12.9	12.5	11.9
	35	32	13.6	13.6	13.6	13.6	13.5	13.2	12.5	11.9
	40	36	14.1	14.1	14.1	14.1	13.6	13.2	12.5	11.9
	45	41	14.7	14.7	14.7	14.3	13.6	13.2	12.5	11.9
	47	43	15.2	15.1	15.0	14.3	13.6	13.2	12.5	11.9
50	46	16.3	15.6	15.0	14.3	13.6	13.2	12.5	11.9	
55	51	16.7	15.8	15.0	14.3	13.6	13.2	12.5	11.9	
60	56	16.7	15.8	15.0	14.3	13.6	13.2	12.5	11.9	

TC: Total Capacity (MBh).

The System Combination Ratio must be between 50–130%.

Rated capacity is certified under AHRI Standard 1230. Ratings are subject to change without notice.

Current certified ratings are available at www.ahridirectory.org.

For outdoor unit performance data, see the respective outdoor unit performance data manuals on <https://lghvac.com/commercial>.

Note:

Low ambient performance with LGRED° heat technology is included in Multi V 5 Air Source Units produced after February 2019.

ART COOL™ MIRROR WALL-MOUNTED

[Mechanical Specifications on page 25](#)

[General Data on page 27](#)

[Electrical Data on page 28](#)

[External Dimensions on page 29](#)

[Electrical Wiring Diagram on page 31](#)

[Refrigerant Flow Diagram on page 32](#)

[Acoustic Data on page 33](#)

[Air Velocity / Temperature Distribution on page 37](#)

[Capacity Tables on page 51](#)



Casing

Units are designed to mount on a vertical surface and come complete with an installation mounting guide and a separate hanging bracket. The unit case is manufactured with coated metal. Cold surfaces are covered with a coated polystyrene insulating material.

Finish

The unit case has a light gray / silver matte finish. The front surface of the unit has an architectural flat panel smoked mirror finish.

Fan Assembly and Control

The unit has a single, direct-drive, crossflow tangential Sirocco fan made of high strength ABS BSN-7530 polymeric resin. The fan motor is a Brushless Digitally Controlled (BLDC) design with permanently lubricated and sealed ball bearings. The fan motor includes thermal, overcurrent and low RPM protection. The fan / motor assembly is mounted on vibration attenuating rubber grommets. The fan impeller is statically and dynamically balanced. The fan speed is controlled using a microprocessor-based direct digital control algorithm that provides a high fan speed in cooling thermal ON and low fan speed in cooling thermal OFF, high fan speed in heating thermal ON and fan off in heating thermal OFF. The fan speeds can be field adjusted between low, medium, and high speeds. The fan speed algorithm provides a field-selectable fixed-speed or auto-speed setting that changes the fan speed to simulate natural airflow.

Air Filter

Return air is filtered with a removable, washable filter with anti-fungal treatment. Filter access is from the front of the unit without the use of tools.

Airflow Guide Vanes

5–15 MBh

The indoor unit is provided with a motorized oscillating guide vane that automatically changes the direction of up-and-down airflow. The indoor unit includes factory installed, manually adjustable guide vanes that control the side-to-side direction of supplied airflow.

18-24 MBh

The indoor unit is provided with a motorized sweeping guide vane that automatically changes the direction of airflow from side-to-side and up-and-down.

Microprocessor Control

The unit is provided with an integrated microprocessor controller capable of performing functions necessary to operate the system without the use of a wall-mounted controller. A temperature thermistor is factory mounted in the return air stream. All unit operation parameters, excluding the operating schedule, are stored in non-volatile memory resident on the unit microprocessor. Operating schedules are stored in select models of the optional, wall-mounted, local or central controllers.



The field-supplied communication cable between the indoor unit(s) and outdoor unit is to be a minimum of 18 AWG, 2 conductor, stranded, and shielded cable (RS-485), terminated via screw terminals on the control boards. The microprocessor control provides the following functions: auto addressing, self-diagnostics, auto restart following power restoration, test run, and will operate the indoor unit using one of five operation modes:

1. Auto Changeover (Heat Recovery only)
2. Heating
3. Cooling
4. Dry
5. Fan Only

For Heat Recovery systems the Auto Changeover setting automatically switches control of the indoor unit between Cooling and Heating modes based on space temperature conditions.

For Heat Pump systems, heated or cooled air delivery is dependent upon outdoor unit operating mode. In Heating mode, the microprocessor control will activate indoor unit operation when the indoor room temperature falls below set-point temperature. At which point, a signal is sent to the outdoor unit to begin the heating cycle. The indoor unit fan operation is delayed until coil pipe temperature reaches 76°F. Significant airflow is generated when pipe temperature reaches 80°F. A field-selectable option maintains fan operation for 30 minutes following cooling cycle operations. The unit is equipped with an infrared receiver designed to communicate with an LG wireless remote controller. In lieu of wireless remote or factory return air thermistor, screw terminals on the microprocessor circuit board accommodate various models of wall-mounted local controllers. The unit microprocessor is capable of accepting space temperature readings concurrently or individually from either:

1. Wall-mounted wired controller(s)
2. Factory-mounted return air thermistor

A single indoor unit has the capability of being controlled by up to two local wired controllers. The microprocessor controls space temperature using the value provided by the temperature sensor sensing a space temperature that is farthest away from the temperature set-point. The microprocessor control provides a cooling or heating mode test cycle that operates the unit for 18 minutes without regard to the space temperature. If the system is provided with an optional wall-mounted local or central controller, displayed diagnostic codes are specific, alpha-numeric, and provide the service technician with a reason for the code displayed.

ART COOL MIRROR

Mechanical Specifications



Indoor units have built-in Wi-Fi and can be controlled by LG ThinQ app on a smart device. A field-supplied Wi-Fi network and smart device are required. The ThinQ app is free, and is available for Android™ and iOS. (Android is a trademark of Google LLC.)

Handling Condensate

The unit is designed for gravity draining of condensate. LG provides a factory insulated flexible drain hose. If condensate lift / pumps are needed for the application, they are to be field provided.

Condensate Drain Pan

The condensate drain pan is constructed of expandable polystyrene resin (EPS).

Coil

The indoor unit coil is constructed with grooved design copper tubes with slit coil fins, two (2) rows, eighteen (18) fins per inch.

Controls Features

- Auto changeover (Heat Recovery only)
- Auto operation
- Auto clean (coil dry; requires wireless controller)
- External on/off control
- Dual thermistor control
- Dual setpoint control
- Filter life display
- Group control
- Forced operation
- Hot start
- Self diagnostics
- Timer (on/off)
- Weekly schedule
- Auto direction/swing (up/down)
- Wi-Fi (built-in)
- Auto Fan
- Leak detection

**To enable Generation 4 features, outdoor unit DIP Switch No. 3 must be set to ON. Please refer to the Multi V 5, Multi V IV, Multi V Water IV, Multi V S Engineering Manual for additional information.*

Table 12: Art Cool Mirror Wall-Mounted (SJ, SK Frames) Indoor Unit General Data.

Model No.	ARNU053SJR4	ARNU073SJR4	ARNU093SJR4	ARNU123SJR4	ARNU153SJR4	ARNU183SKR4	ARNU243SKR4
Cooling Mode Performance							
Capacity (Btu/h)	5,500	7,500	9,600	12,300	15,400	19,100	24,200
Max. Power Input ¹ (W)	30	30	30	30	30	53	53
H / M / L Power Input at Factory Default (W)	11 / 10 / 9	12 / 11 / 9	13 / 12 / 9	15 / 13 / 11	23 / 18 / 11	32 / 26 / 16	39 / 26 / 16
Heating Mode Performance							
Capacity (Btu/h)	6,100	8,500	10,900	13,600	17,100	21,500	25,600
Max. Power Input ¹ (W)	30	30	30	30	30	53	53
H / M / L Power Input at Factory Default (W)	11 / 10 / 9	12 / 11 / 9	13 / 12 / 9	15 / 13 / 11	23 / 18 / 11	32 / 26 / 16	39 / 26 / 16
Entering Mixed Air							
Cooling Max (°F WB) ²	76	76	76	76	76	76	76
Heating Min (°F DB) ²	59	59	59	59	59	59	59
Unit Data							
Refrigerant Type ³	R410A	R410A	R410A	R410A	R410A	R410A	R410A
Refrigerant Control	EEV	EEV	EEV	EEV	EEV	EEV	EEV
Sound Pressure ⁴ dB(A) (H / M / L)	30 / 29 / 28	32 / 30 / 28	34 / 32 / 28	37 / 34 / 30	42 / 39 / 32	43 / 39 / 34	46 / 41 / 34
Net Unit Weight (lbs.)	21.6	21.6	21.6	21.6	21.6	30.6	30.6
Shipping Weight (lbs.)	23.8	23.8	23.8	23.8	23.8	34.2	34.2
Communication Cable ⁵ (No. x AWG)	2 x 18	2 x 18	2 x 18	2 x 18	2 x 18	2 x 18	2 x 18
Fan							
Type	Cross Flow	Cross Flow	Cross Flow	Cross Flow	Cross Flow	Cross Flow	Cross Flow
Quantity	1	1	1	1	1	1	1
Motor / Drive	Brushless Digitally Controlled / Direct						
Airflow Rate H / M / L (CFM)	240 / 230 / 208	254 / 240 / 208	275 / 254 / 208	300 / 254 / 240	371 / 336 / 240	494 / 424 / 371	537 / 449 / 371
Piping							
Liquid Line (in., O.D.)	1/4 Flare	1/4 Flare	1/4 Flare	1/4 Flare	1/4 Flare	1/4 Flare	3/8 Flare
Vapor Line (in., O.D.)	1/2 Flare	1/2 Flare	1/2 Flare	1/2 Flare	1/2 Flare	1/2 Flare	5/8 Flare
Condensate Line (in., I.D.)	5/8	5/8	5/8	5/8	5/8	5/8	5/8

EEV: Electronic Expansion Valve

Power wiring is field supplied and must comply with the applicable local and national codes.

This unit comes with a dry nitrogen charge.

All capacities are net with a combination ratio between 95-105%.

Rated capacity is certified under AHRI Standard 1230. Ratings are subject to change without notice. Current certified ratings are available at www.ahridirectory.org.

¹Max. power input is rated at maximum setting value.

²Low ambient performance with LGRED[®] heat technology is included in Multi V 5 Air

Source Units produced after February 2019.

³Take appropriate actions at the end of HVAC equipment life to recover, recycle, reclaim or destroy R410A refrigerant according to applicable regulations (40 CFR Part 82, Subpart F) under section 608 of CAA.

⁴Sound Pressure levels are tested in an anechoic chamber under ISO Standard 3745.

⁵All communication cable to be minimum 18 AWG, 2-conductor, twisted, stranded, shielded and must comply with applicable local and national codes. Ensure the communication cable is properly grounded at the main outdoor unit only. Ⓢ Do not ground the ODU-IDU communication cable at any other point.

ART COOL MIRROR



Electrical Data

Table 13: Art Cool Mirror Wall-Mounted Indoor Unit Electrical Data.

Model Number	Voltage Range	MCA	MOP	Rated Amps (A)	Power Supply			Power Input (W)		
					Hz	Volts	Phase	Max. Cooling	Max. Heating	H / M / L at Factory Default
<i>SJ Frames</i>										
ARNU053SJR4	187-253	0.31	15	0.25	60	208-230V	1	30	30	11 / 10 / 9
ARNU073SJR4		0.31		0.25				30	30	12 / 11 / 9
ARNU093SJR4		0.31		0.25				30	30	13 / 12 / 9
ARNU123SJR4		0.31		0.25				30	30	15 / 13 / 11
ARNU153SJR4		0.31		0.25				30	30	23 / 18 / 11
<i>SK Frames</i>										
ARNU183SKR4	187-253	0.65	15	0.52	60	208-230V	1	53	53	32 / 26 / 16
ARNU243SKR4		0.65		0.52				53	53	39 / 26 / 16

MCA : Minimum Circuit Ampacity.

MOP : Maximum Overcurrent Protection.

Units are suitable for use on an electrical system where voltage supplied to unit terminals is within the listed range limits.

Select wire size based on the larger MCA value.

Instead of fuse, use the circuit breaker.

Max. power input is rated at maximum setting value.

Figure 11: ARNU053SJR4, ARNU073SJR4, ARNU093SJR4, ARNU123SJR4, ARNU153SJR4 Dimensions.

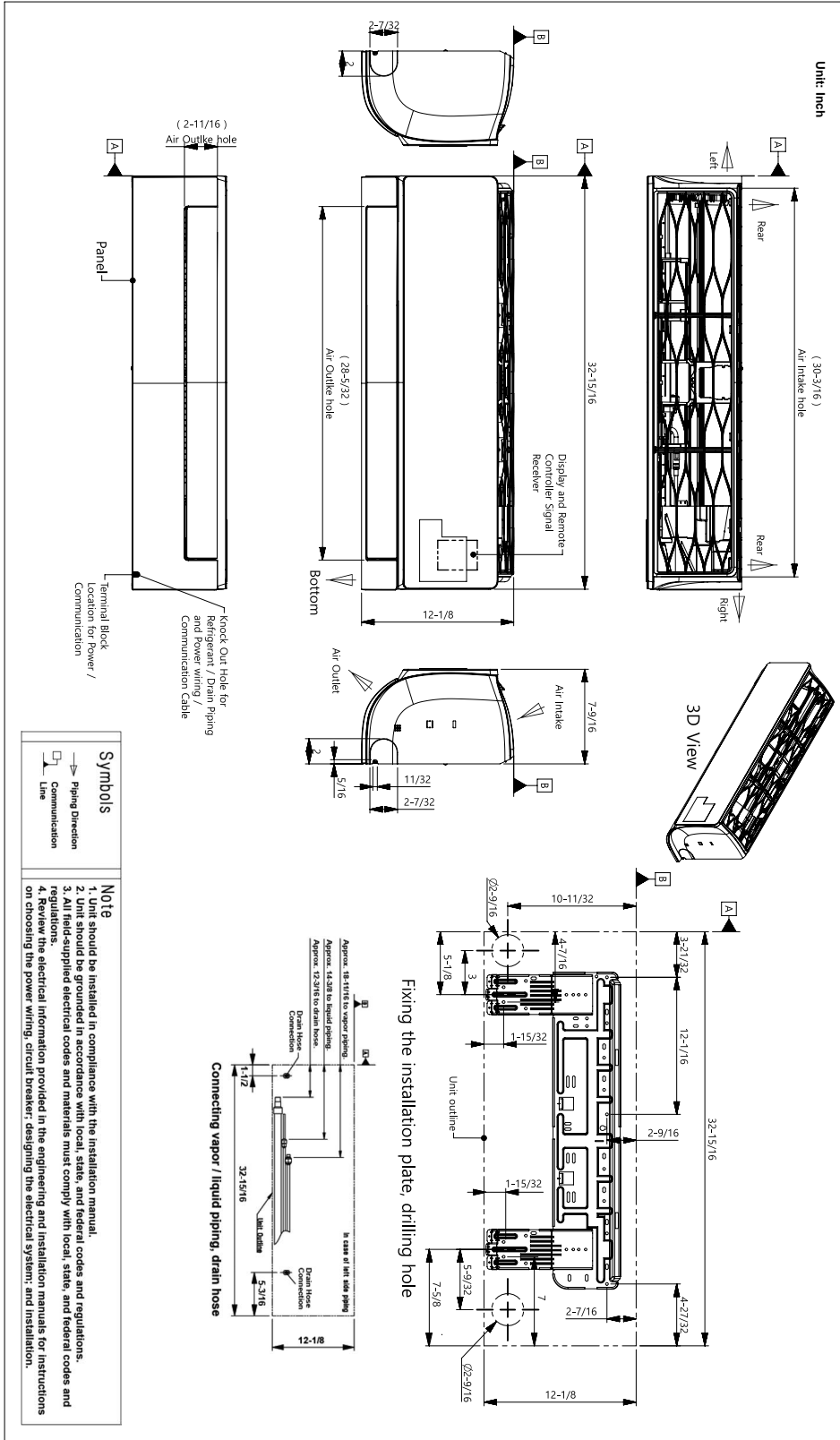

Figure 13: ARNU053~153SJR4 and ARNU183-243SKR4 Wiring Diagram.

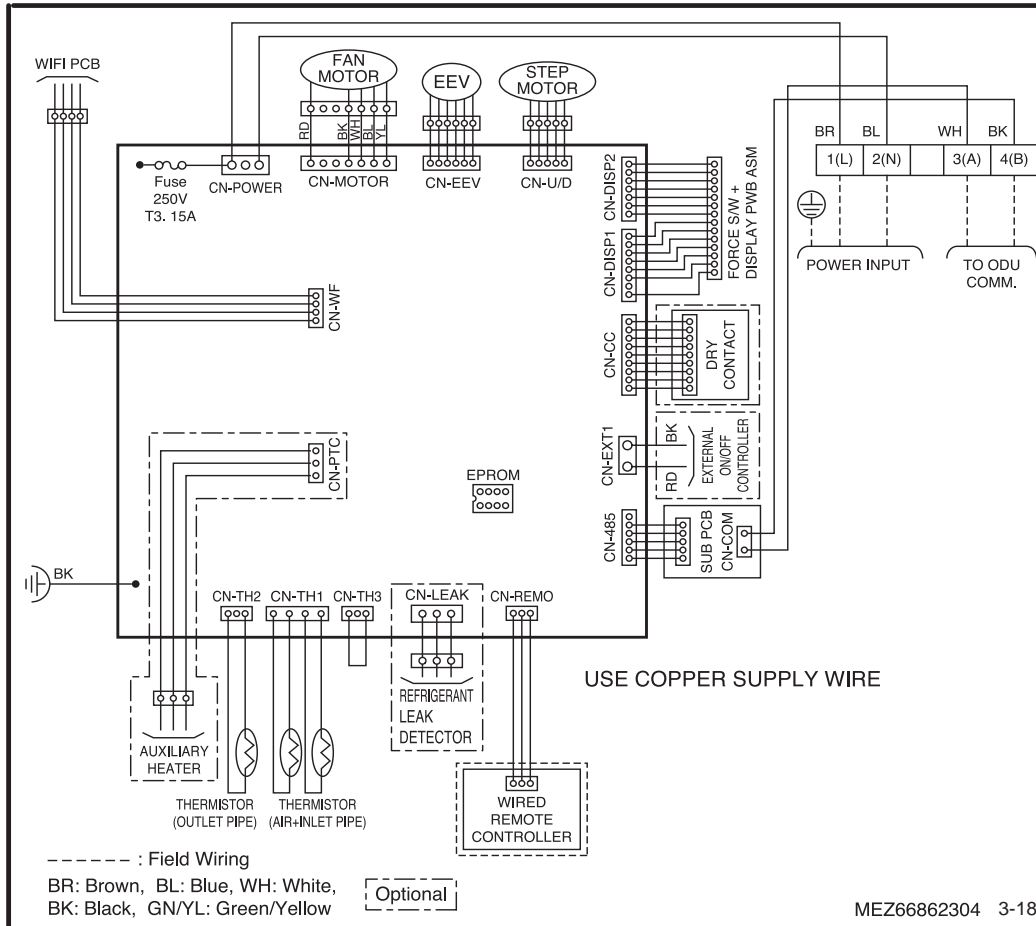

Table 14: SJ and SK Frame Wiring Diagram Legend.

PCB Connection	Purpose	Function
CN-POWER	AC power supply	AC Power line input for indoor controller
CN-MOTOR	Fan motor output	Motor output of BLDC
CN-EEV	EEV output	EEV control output
CN-U/D	Step motor	Step motor output
CN-DISP2	Display	Display of indoor status
CN-DISP1	Display	Display of indoor status
CN-CC	Dry contact	Dry contact connection
CN-EXT1	External ON / OFF controller	External ON / OFF controller connection
CN-485	Communication	Connection between indoor and outdoor units
CN-REMO	Remote controller	Remote control connection
CN-LEAK	Refrigerant leak detector	Refrigerant leak detector connection
CN-TH3	Float switch	Float switch connection
CN-TH1	Return air and inlet pipe thermistor	Return air and inlet pipe thermistor connection
CN-TH2	Outlet pipe thermistor	Outlet pipe thermistor connection
CN-PTC	Auxiliary heater	Auxiliary heater connection
CN-WF	Wi-Fi module	Wi-Fi module connection

*To enable Generation 4 features, outdoor unit DIP switch no. 3 must be set to ON. Please refer to the Multi V 5, Multi V IV, Multi V Water IV, Multi V S Engineering Manual for additional information.

ART COOL MIRROR

Refrigerant Flow Diagram

SJ and SK Frames

Figure 14: SJ, SK Frame Piping Diagram.

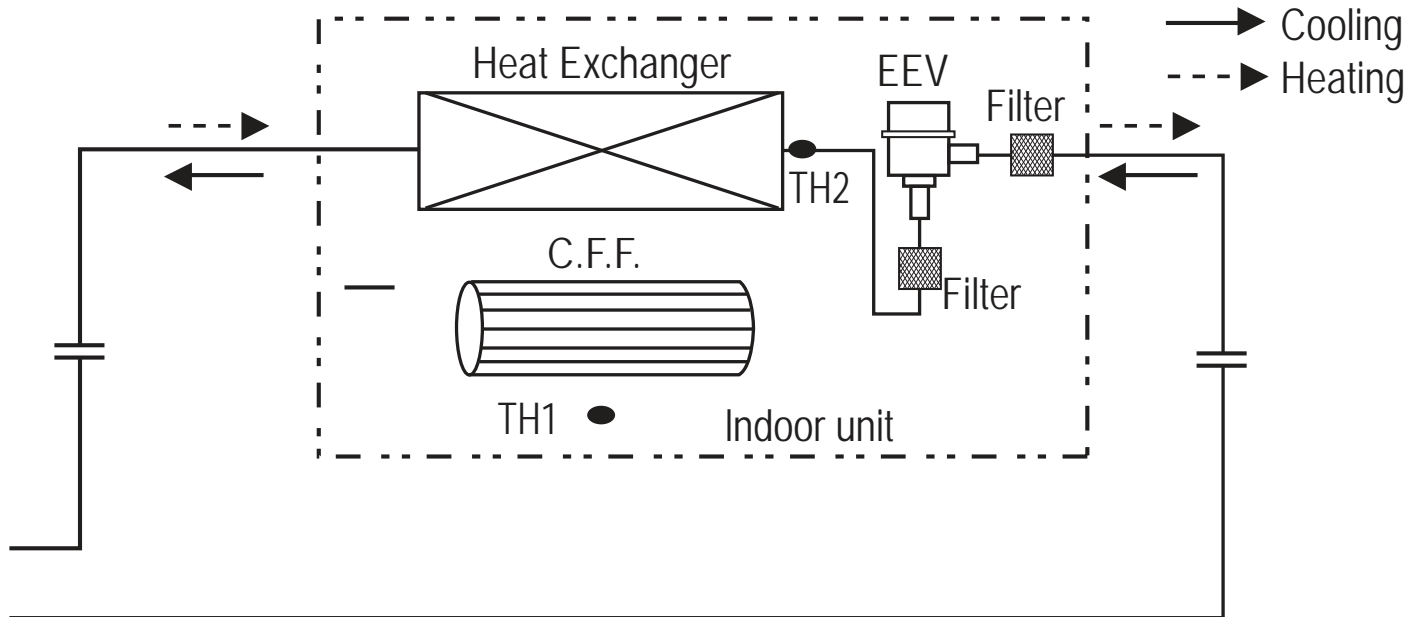

Table 15: SJ, SK Frame Refrigerant Pipe Connection Port Diameters.

Model	Liquid (inch)	Vapor (inch)
SJ Frames		
ARNU053SJR4	1/4 Flare	1/2 Flare
ARNU073SJR4		
ARNU093SJR4		
ARNU123SJR4		
ARNU153SJR4		
SK Frames		
ARNU183SKR4	1/4 Flare	1/2 Flare
ARNU243SKR4	3/8 Flare	5/8 Flare

Table 16: SJ, SK Frame Thermistors.

Thermistor	Description
TH1	Return air and pipe in thermistor
TH2	Pipe out thermistor

Figure 15: Sound Pressure Measurement Location.

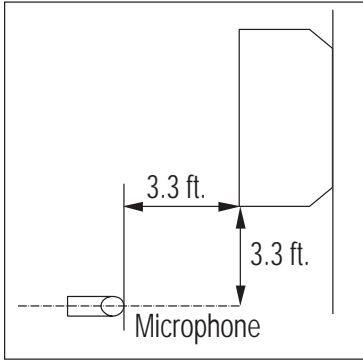

- Measurements are taken 3.3 ft away from the front of the unit.
- Data is valid under nominal operating conditions.
- Sound pressure levels are measured in dB(A) with a tolerance of ± 3 .
- Sound pressure levels are tested in an anechoic chamber under ISO Standard 3745.
- Reference acoustic pressure: 0dB = 20 μ Pa.

Operating Conditions:

- Power source: 220V/60 Hz
- Sound level will vary depending on a range of factors including the construction (acoustic absorption coefficient) of a particular room in which the unit was installed.

Table 17: Art Cool Mirror Wall-Mounted Indoor Unit Sound Pressure Levels.

Model	Sound Pressure Levels dB(A)		
	High Fan Speed	Medium Fan Speed	Low Fan Speed
SJ Frames			
ARNU053SJR4	30.0	29.0	28.0
ARNU073SJR4	32.0	30.0	28.0
ARNU093SJR4	34.0	32.0	28.0
ARNU123SJR4	37.0	34.0	30.0
ARNU153SJR4	42.0	39.0	32.0
SK Frames			
ARNU183SKR4	43.0	39.0	34.0
ARNU243SKR4	46.0	41.0	34.0

Figure 16: ARNU053SJR4, ARNU073SJR4, and ARNU093SJR4 Sound Pressure Level Diagrams.

ARNU053SJR4

ARNU073SJR4

ARNU093SJR4

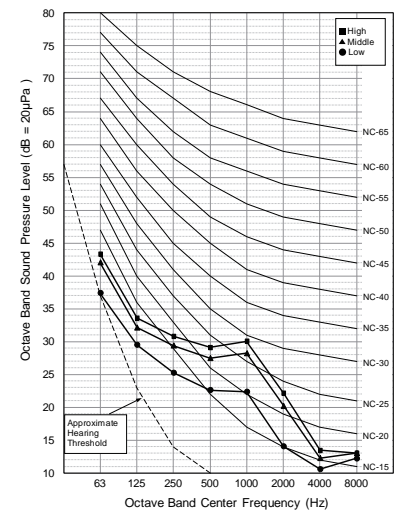
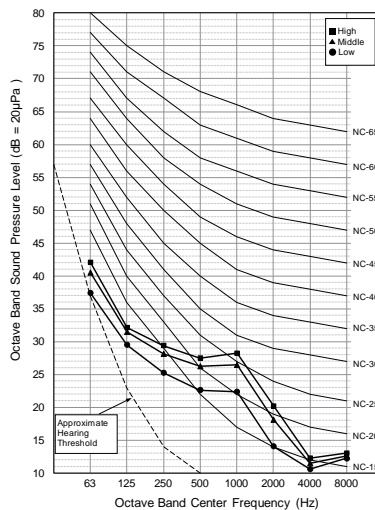
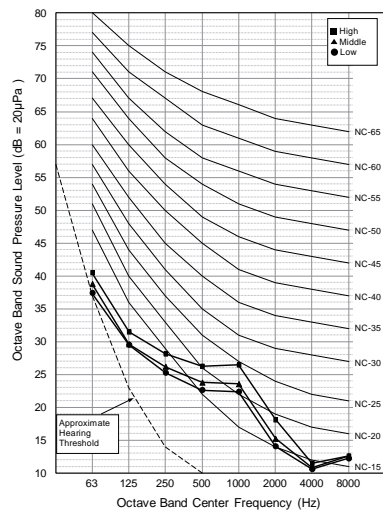

ART COOL MIRROR



Acoustic Data

Sound Pressure Levels

Figure 17: ARNU123SJR4, ARNU153SJR4, and ARNU183SKR4 Sound Pressure Level Diagrams.

ARNU123SJR4

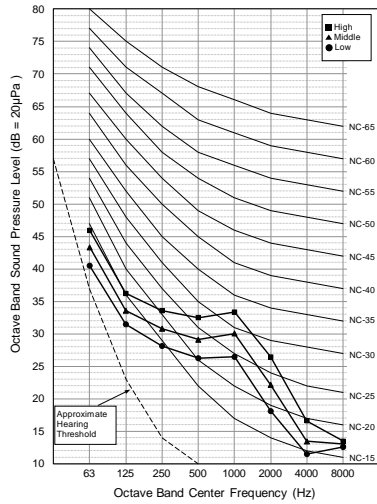

ARNU153SJR4

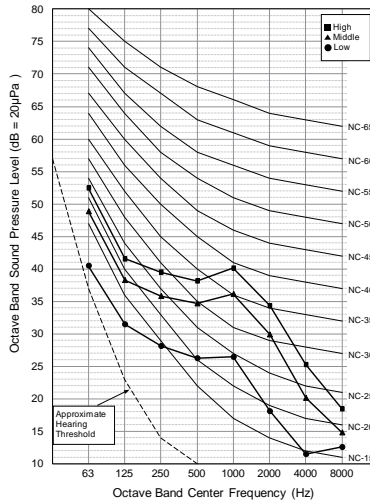

ARNU183SKR4

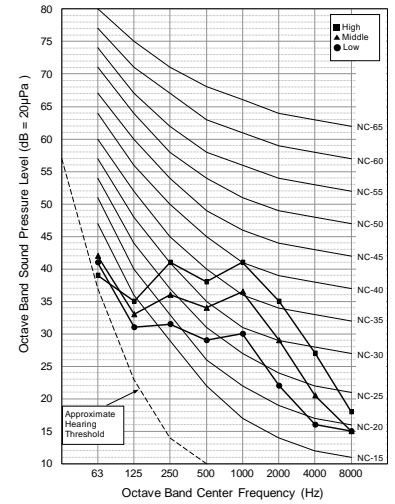

Figure 18: ARNU243SKR4 Sound Pressure Level Diagrams.

ARNU243SKR4

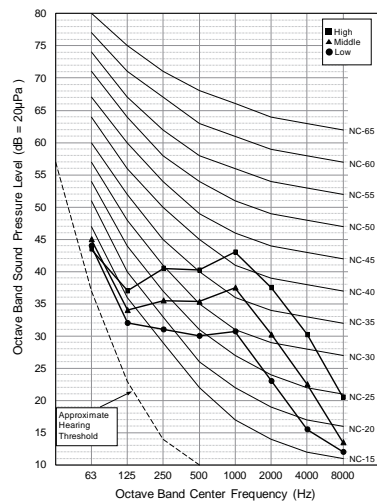

Table 18: Art Cool Mirror Wall-Mounted Indoor Unit Sound Power Levels.

Model	Sound Power Levels dB(A)
	High Fan Speed
SJ Frames	
ARNU053SJR4	54.0
ARNU073SJR4	54.0
ARNU093SJR4	55.0
ARNU123SJR4	55.0
ARNU153SJR4	58.0
SK Frames	
ARNU183SKR4	63.0
ARNU243SKR4	65.0

- Data is valid under diffuse field conditions.
- Data is valid under nominal operating conditions.
- Sound power level is measured using rated conditions, and tested in a reverberation room per ISO 3741 standards.
- Sound level will vary depending on a range of factors such as construction (acoustic absorption coefficient) of particular area in which the equipment is installed.
- Reference acoustic intensity: 0dB = 10E-6μW/m²

Figure 19: ARNU053SJR4, ARNU073SJR4, and ARNU093SJR4 Sound Power Level Diagrams.

ARNU053SJR4

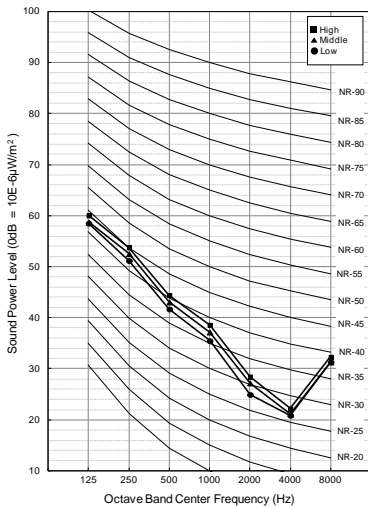

ARNU073SJR4

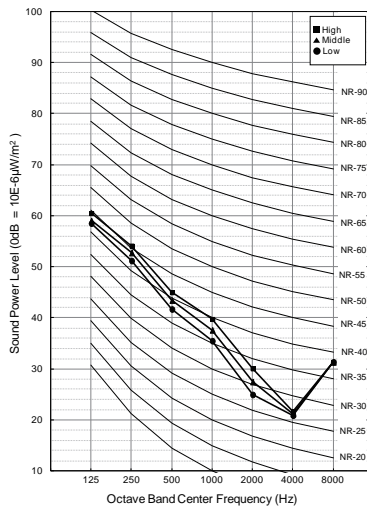

ARNU093SJR4

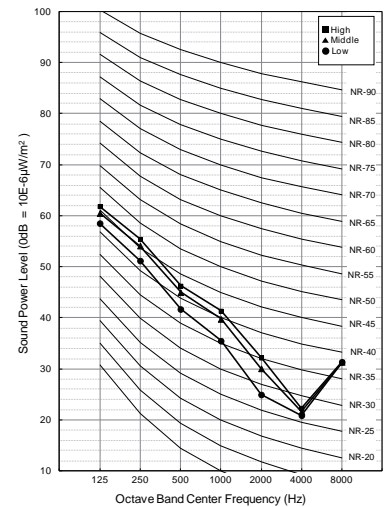

ART COOL MIRROR



Acoustic Data

Sound Power Levels

Figure 20: ARNU123SJR4, ARNU153SJR4, ARNU183SKR4 Sound Power Level Diagrams.

ARNU123SJR4

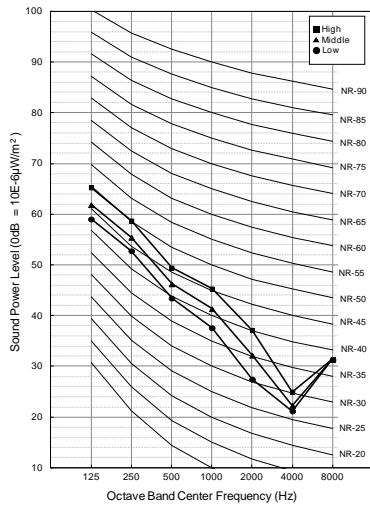

ARNU153SJR4

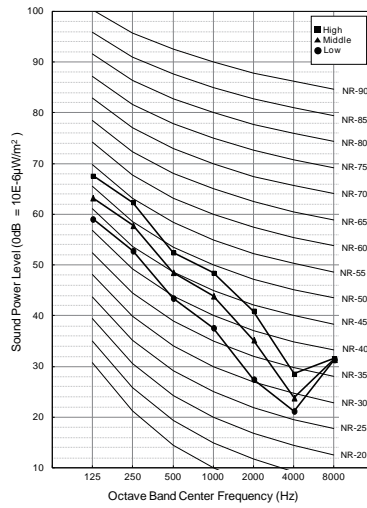

ARNU183SKR4

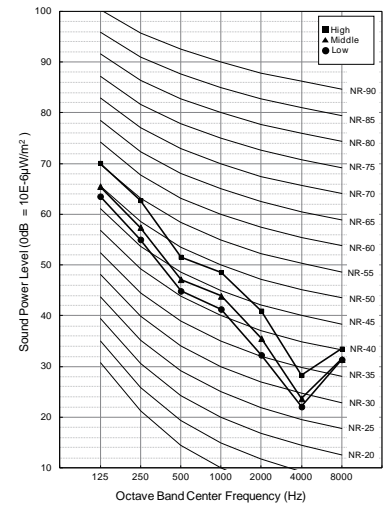
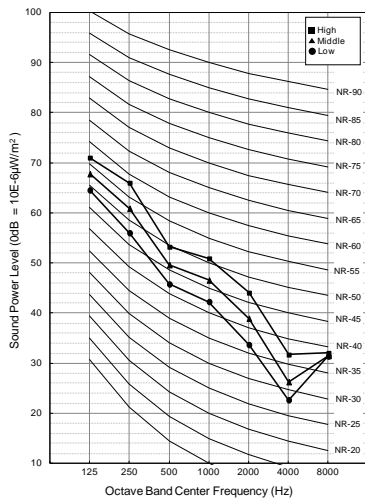

Figure 21: ARNU243SKR4 Sound Power Level Diagrams.

ARNU243SKR4



ARNU053SJR4

Cooling

Side View

Discharge angle: 35°

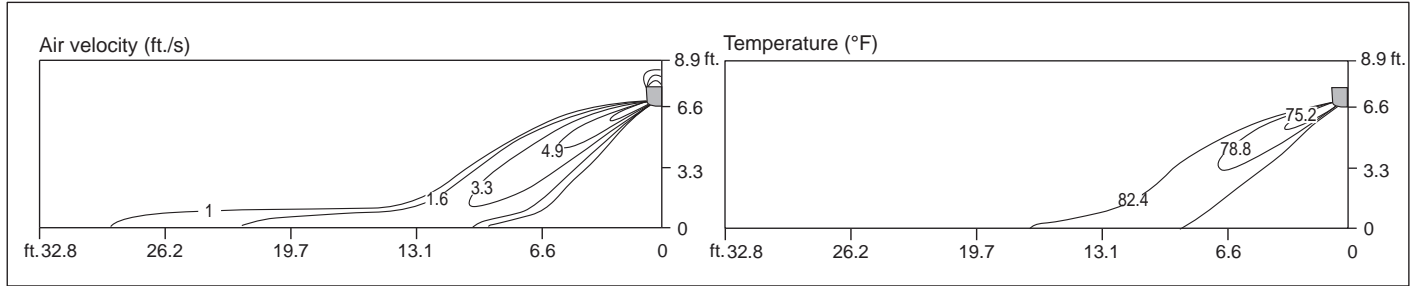

- Vertical Louver : Center
- Vertical Louver Angle : 0°
- Fan Speed : High

Top View

Discharge angle: 35°

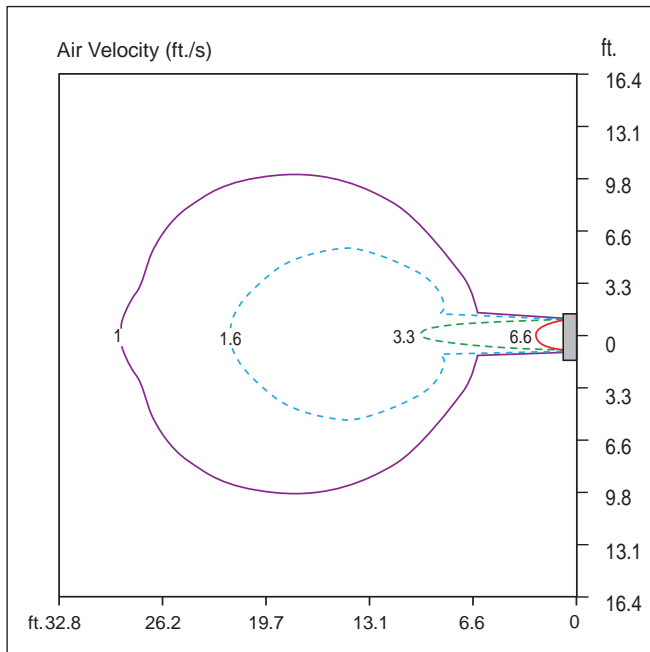

- Vertical Louver : Center
- Vertical Louver Angle : 0°
- Air Speed 1 ft./s Range : 29.2 ft.
- Fan Speed : High

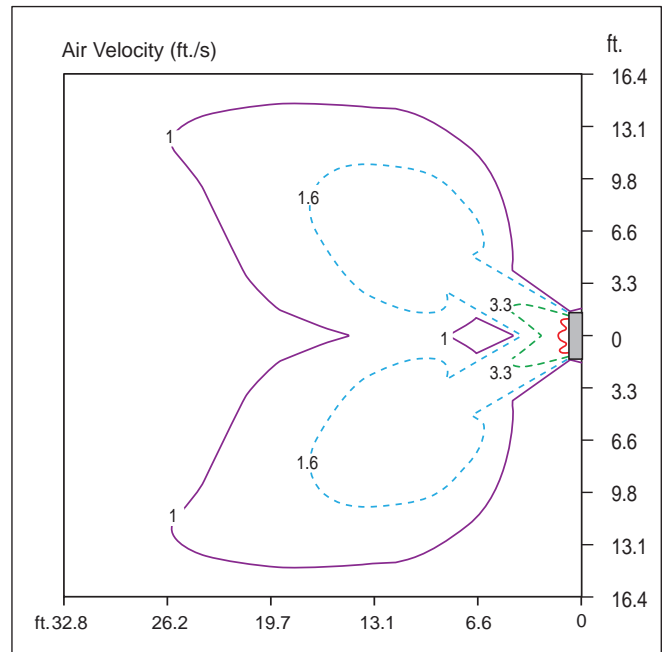

- Vertical Louver : Left and Right
- Vertical Louver Angle : 50°
- Air Speed 1 ft./s Range : 26.2 ft.
- Fan Speed : High

ART COOL MIRROR



Air Velocity / Temperature Distribution

ARNU053SJR4

Heating

Side View

Discharge angle: 55°

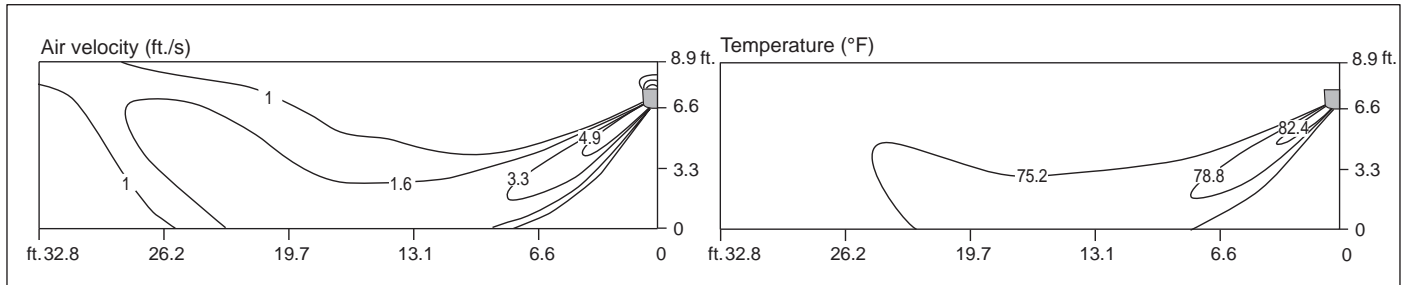

- Vertical Louver : Center
- Vertical Louver Angle : 0°
- Fan Speed : High

Top View

Discharge angle: 55°

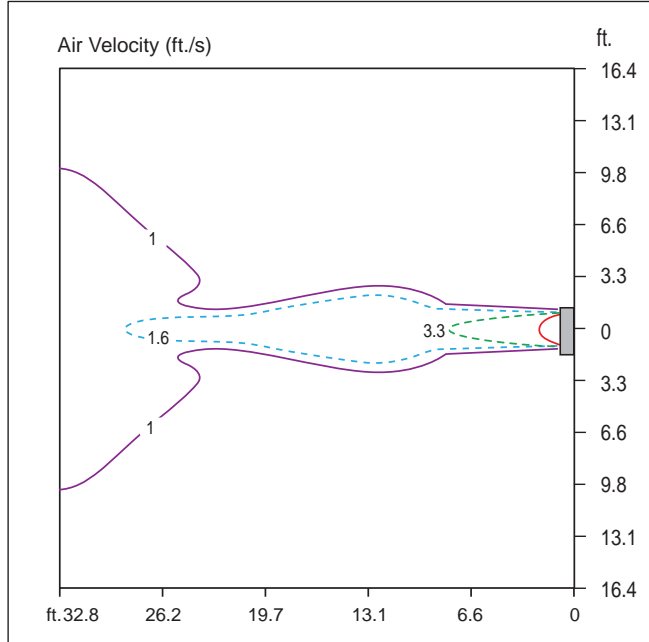

- Vertical Louver : Center
- Vertical Louver Angle : 0°
- Air Speed 1 ft./s Range : 39.0 ft.
- Fan Speed : High

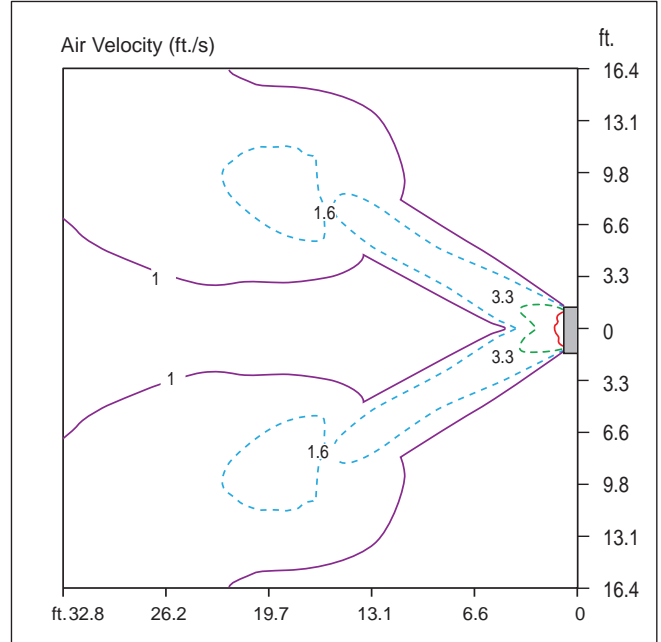

- Vertical Louver : Left and Right
- Vertical Louver Angle : 50°
- Air Speed 1 ft./s Range : 41.3 ft.
- Fan Speed : High

ARNU073SJR4

Cooling

Side View

Discharge angle: 35°

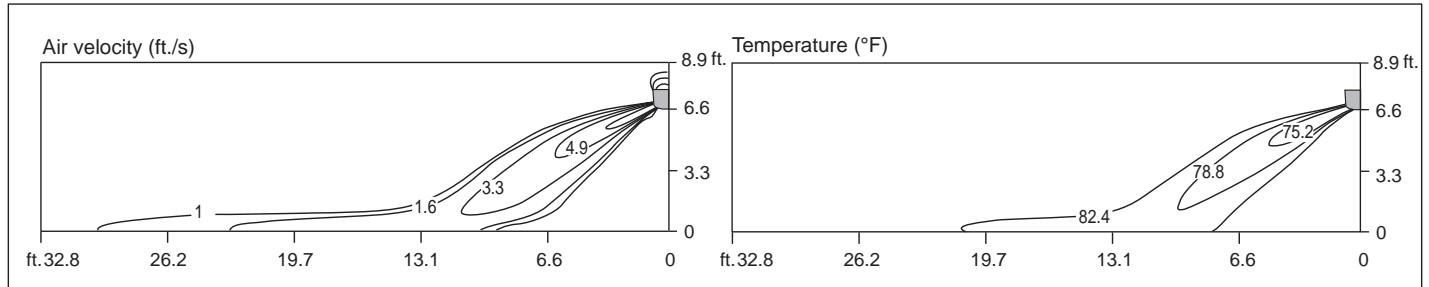

- Vertical Louver : Center
- Vertical Louver Angle : 0°
- Fan Speed : High

Top View

Discharge angle: 35°

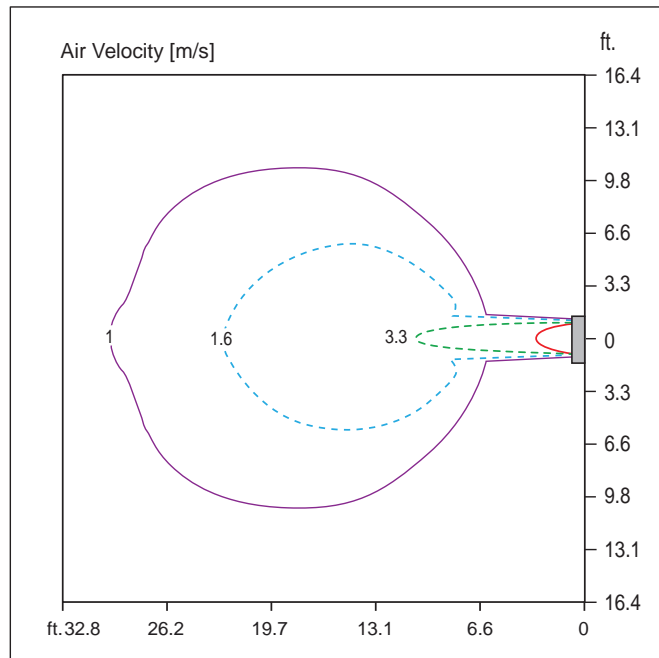

- Vertical Louver : Center
- Vertical Louver Angle : 0°
- Air Speed 1 ft./s Range : 30.2 ft.
- Fan Speed : High

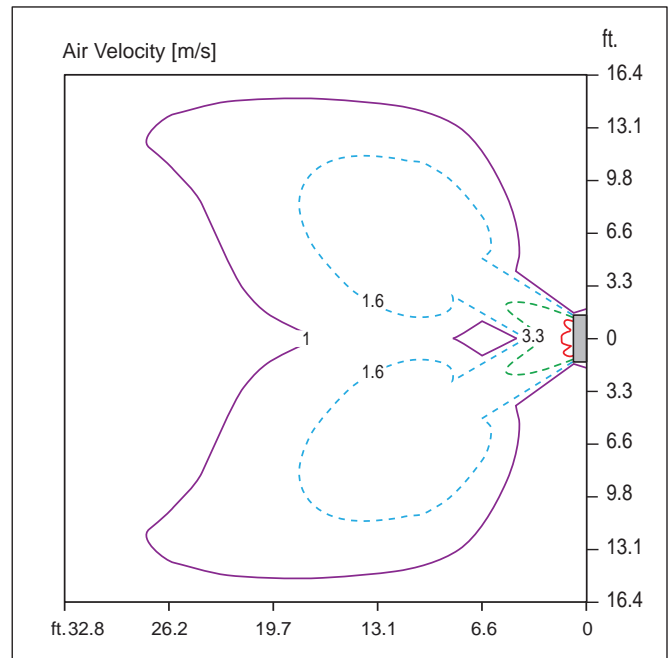

- Vertical Louver : Left and Right
- Vertical Louver Angle : 50°
- Air Speed 1 ft./s Range : 27.6 ft.
- Fan Speed : High

ART COOL MIRROR



Air Velocity / Temperature Distribution

ARNU073SJR4

Heating

Side View

Discharge angle: 55°

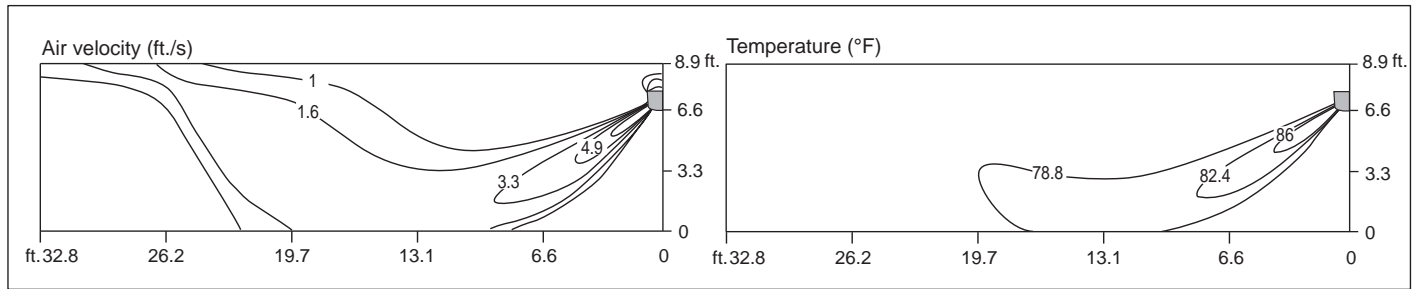

- Vertical Louver : Center
- Vertical Louver Angle : 0°
- Fan Speed : High

Top View

Discharge angle: 55°

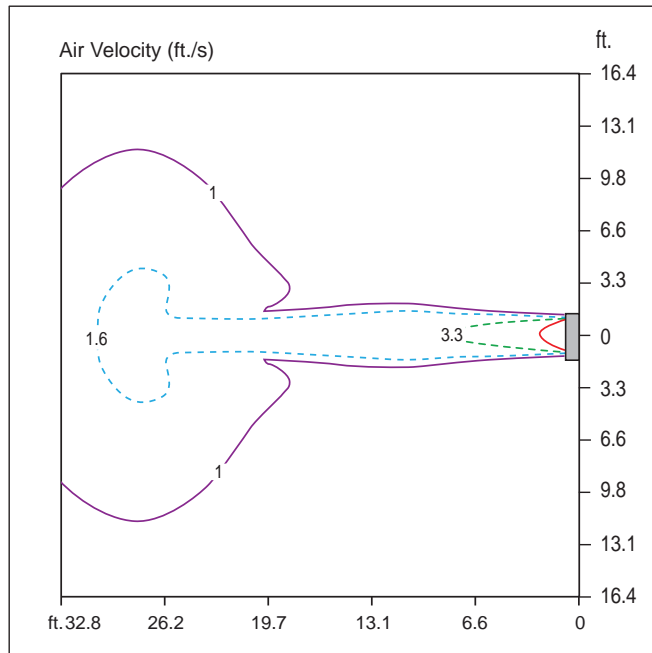

- Vertical Louver : Center
- Vertical Louver Angle : 0°
- Air Speed 1 ft./s Range : 36.1 ft.
- Fan Speed : High

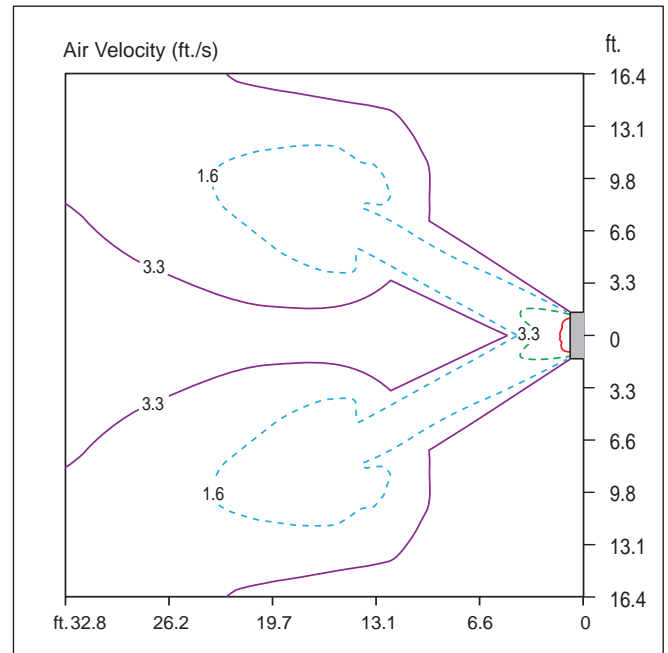

- Vertical Louver : Left and Right
- Vertical Louver Angle : 50°
- Air Speed 1 ft./s Range : 43.3 ft.
- Fan Speed : High

ARNU093SJR4

Cooling

Side View

Discharge angle: 35°

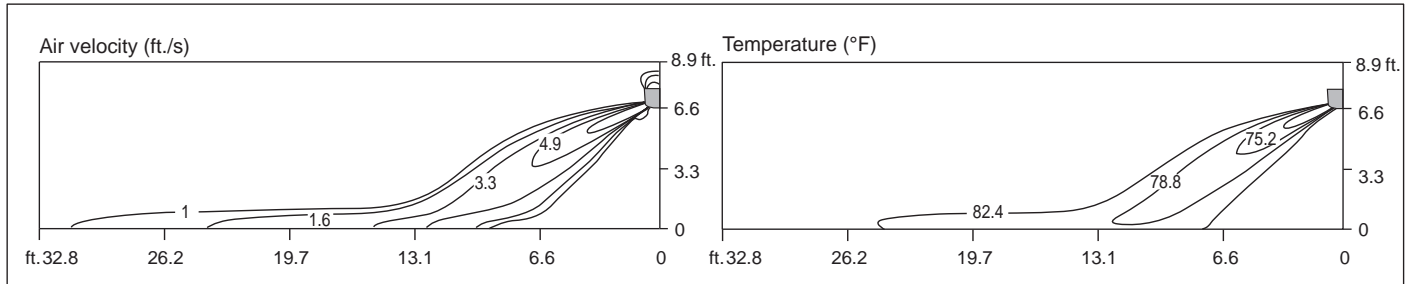

- Vertical Louver : Center
- Vertical Louver Angle : 0°
- Fan Speed : High

Top View

Discharge angle: 35°

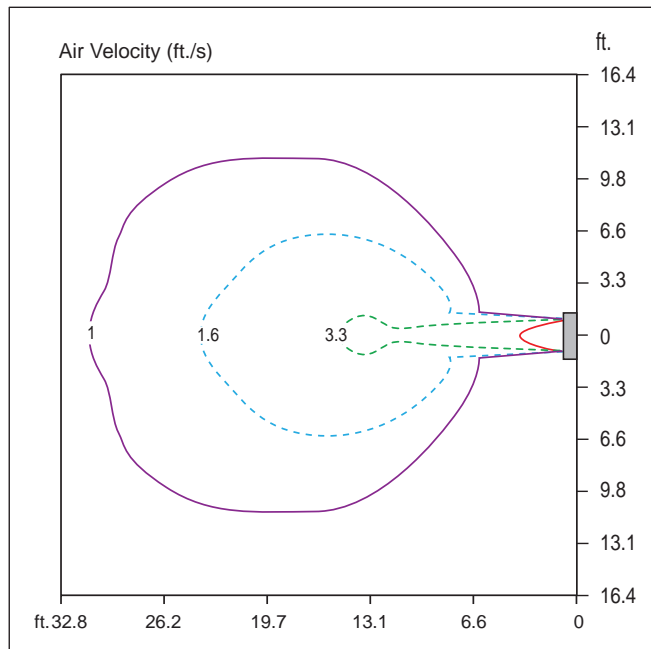

- Vertical Louver : Center
- Vertical Louver Angle : 0°
- Air Speed 1 ft./s Range : 31.5 ft.
- Fan Speed : High

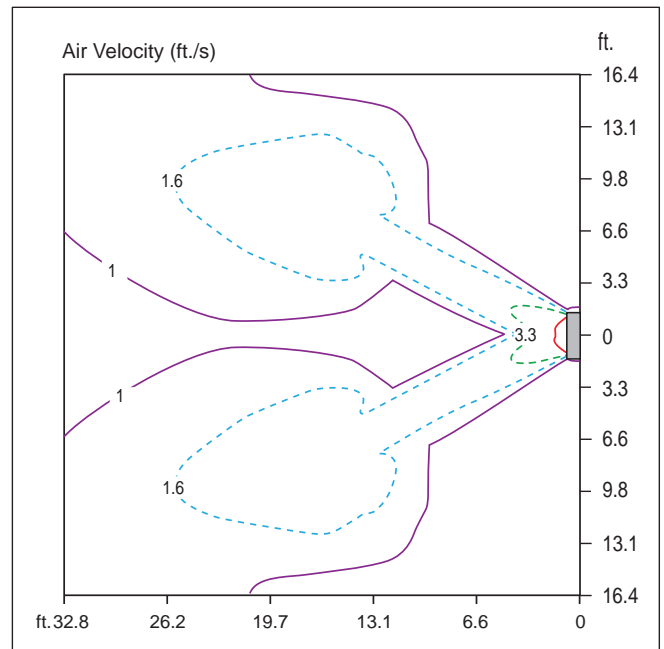

- Vertical Louver : Left and Right
- Vertical Louver Angle : 50°
- Air Speed 1 ft./s Range : 45.9 ft.
- Fan Speed : High

ART COOL MIRROR



Air Velocity / Temperature Distribution

ARNU093SJR4

Heating

Side View

Discharge angle: 55°

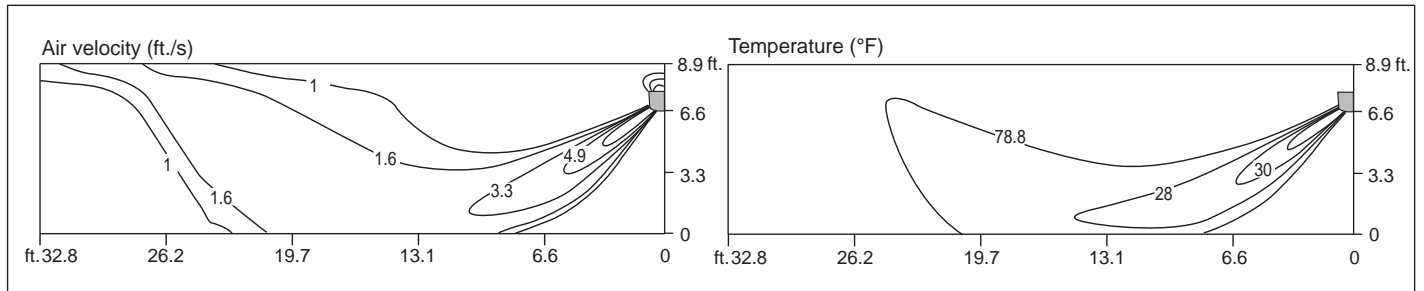

- Vertical Louver : Center
- Vertical Louver Angle : 0°
- Fan Speed : High

Top View

Discharge angle: 55°

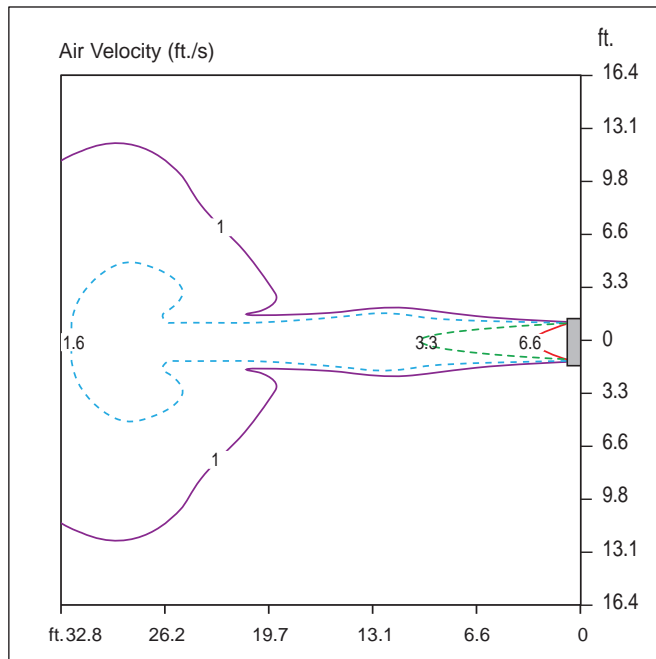

- Vertical Louver : Center
- Vertical Louver Angle : 0°
- Air Speed 1 ft./s Range : 38.7 ft.
- Fan Speed : High

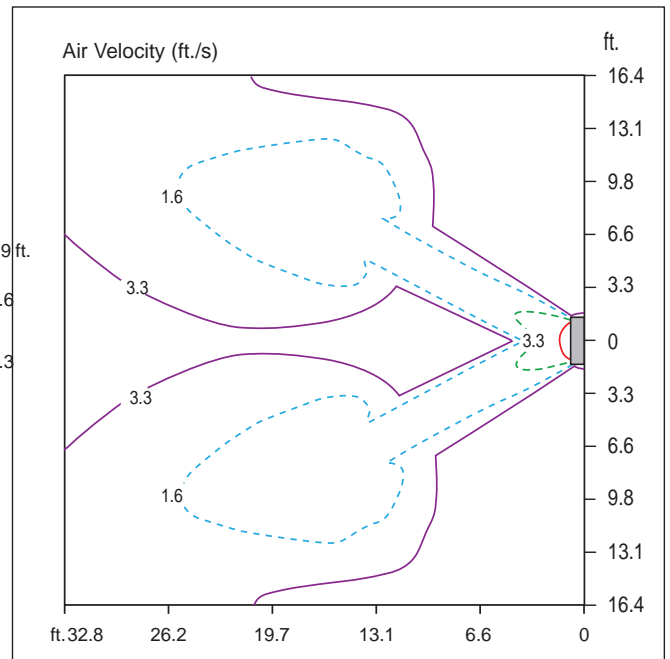

- Vertical Louver : Left and Right
- Vertical Louver Angle : 50°
- Air Speed 1 ft./s Range : 45.9 ft.
- Fan Speed : High

ARNU123SJR4

Cooling

Side View

Discharge angle: 35°

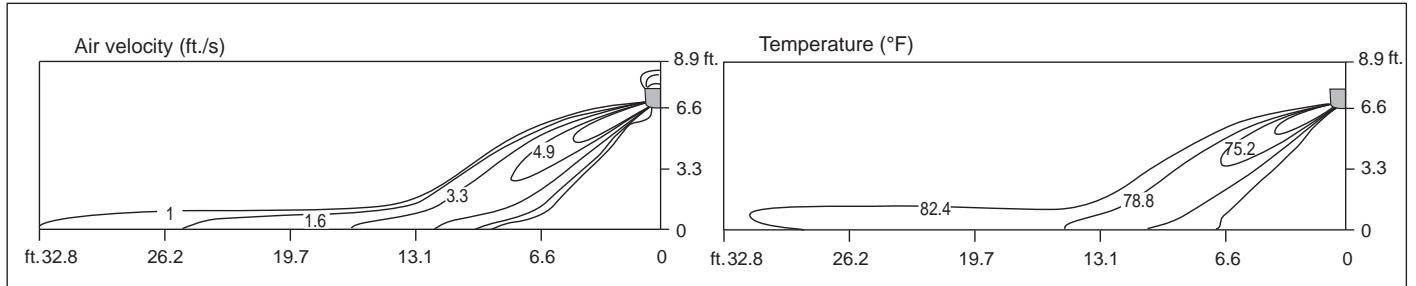

- Vertical Louver : Center
- Vertical Louver Angle : 0°
- Fan Speed : High

Top View

Discharge angle: 35°

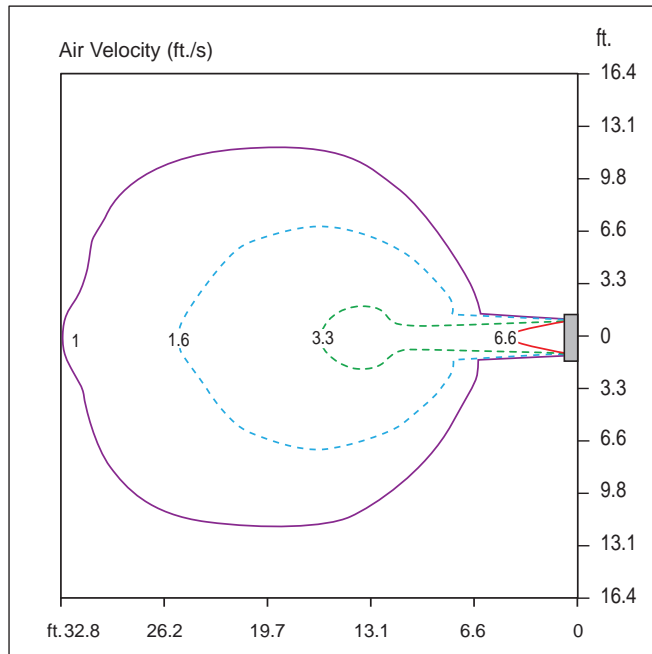

- Vertical Louver : Center
- Vertical Louver Angle : 0°
- Air Speed 1 ft./s Range : 32.8 ft.
- Fan Speed : High

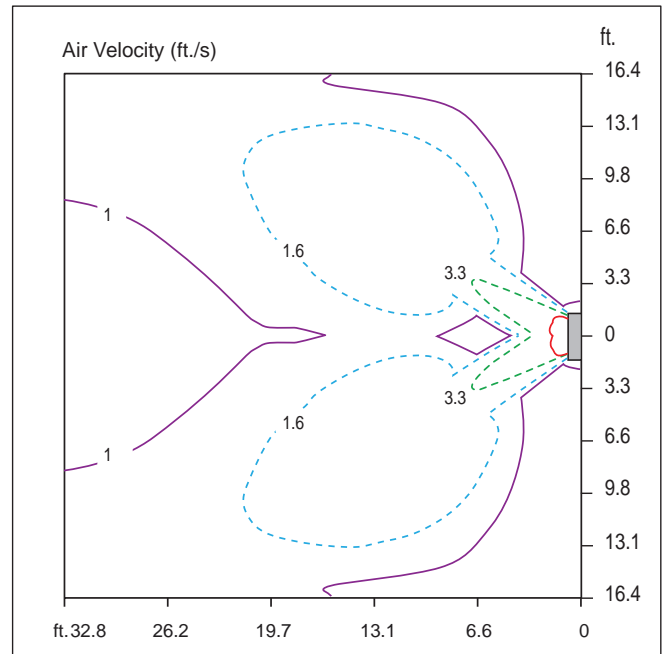

- Vertical Louver : Left and Right
- Vertical Louver Angle : 50°
- Air Speed 1 ft./s Range : 46.9 ft.
- Fan Speed : High

ART COOL MIRROR



Air Velocity / Temperature Distribution ARNU123SJR4

Heating

Side View

Discharge angle: 55°

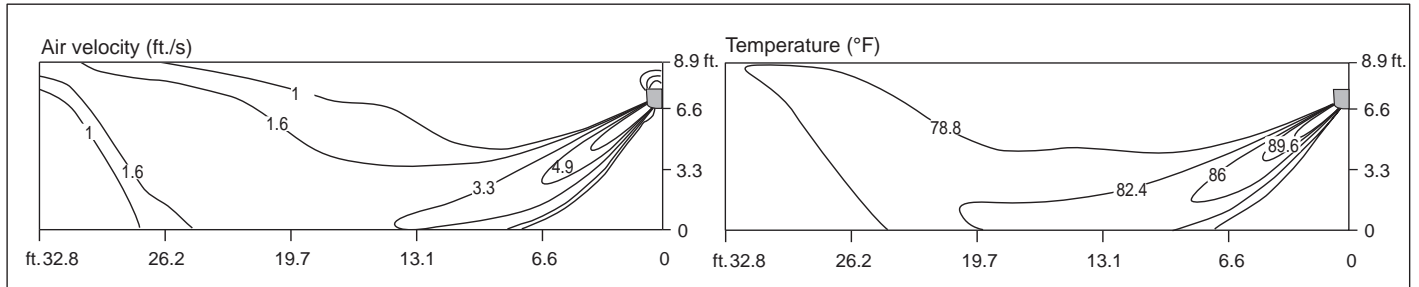

- Vertical Louver : Center
- Vertical Louver Angle : 0°
- Fan Speed : High

Top View

Discharge angle: 55°

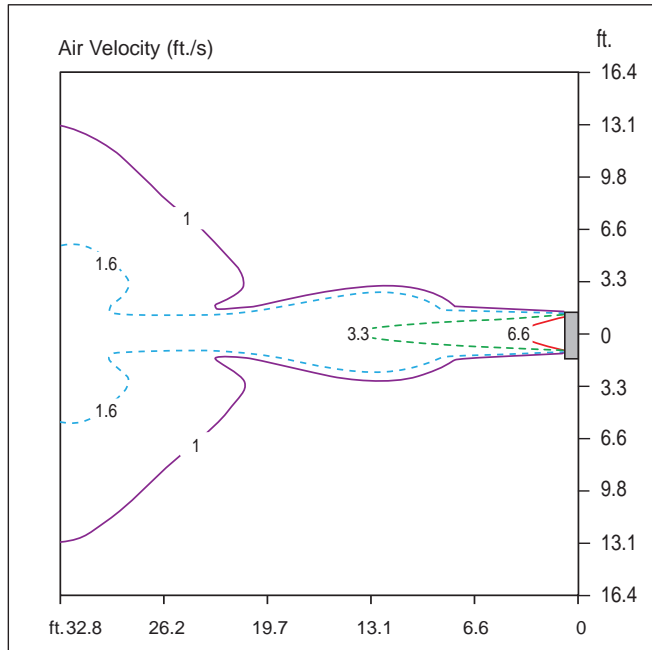

- Vertical Louver : Center
- Vertical Louver Angle : 0°
- Air Speed 1 ft./s Range : 42.6 ft.
- Fan Speed : High

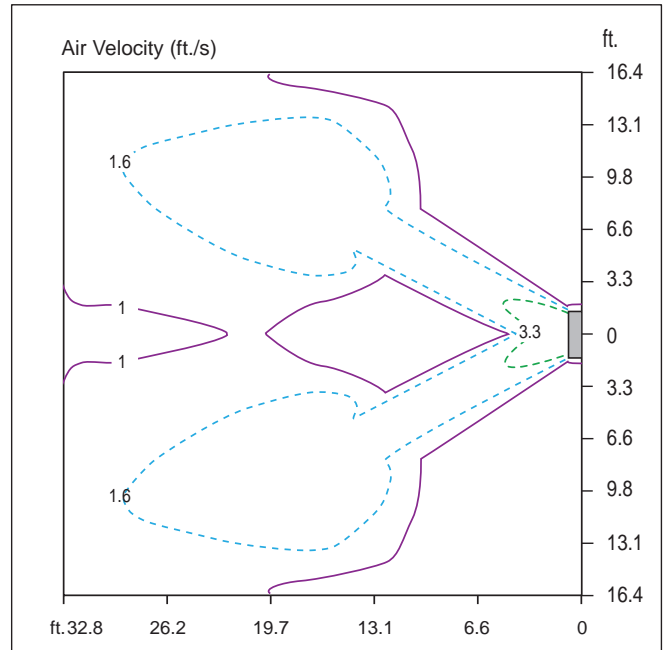

- Vertical Louver : Left and Right
- Vertical Louver Angle : 50°
- Air Speed 1 ft./s Range : 46.9 ft.
- Fan Speed : High

ARNU153SJR4

Cooling

Side View

Discharge angle: 35°

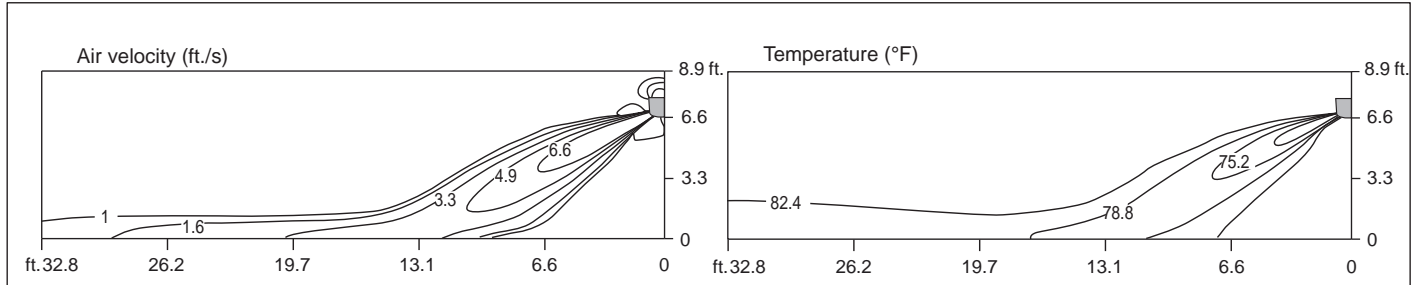

- Vertical Louver : Center
- Vertical Louver Angle : 0°
- Fan Speed : High

Top View

Discharge angle: 35°

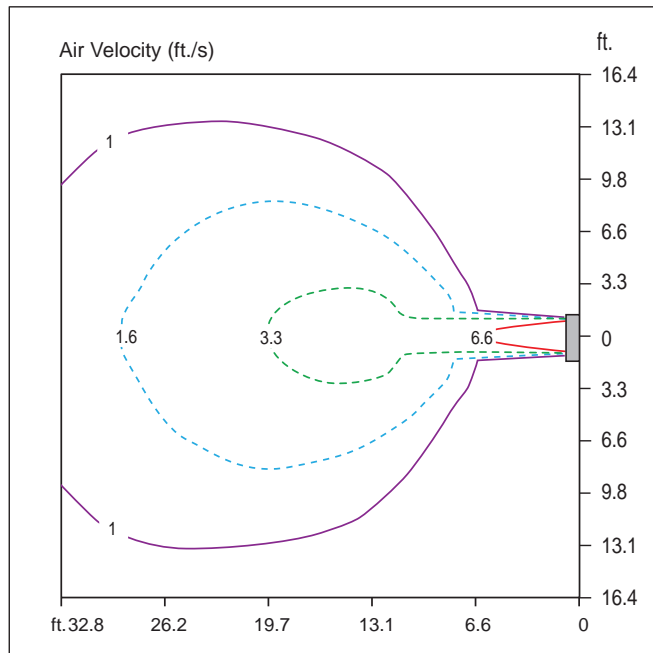

- Vertical Louver : Center
- Vertical Louver Angle : 0°
- Air Speed 1 ft./s Range : 37.7 ft.
- Fan Speed : High

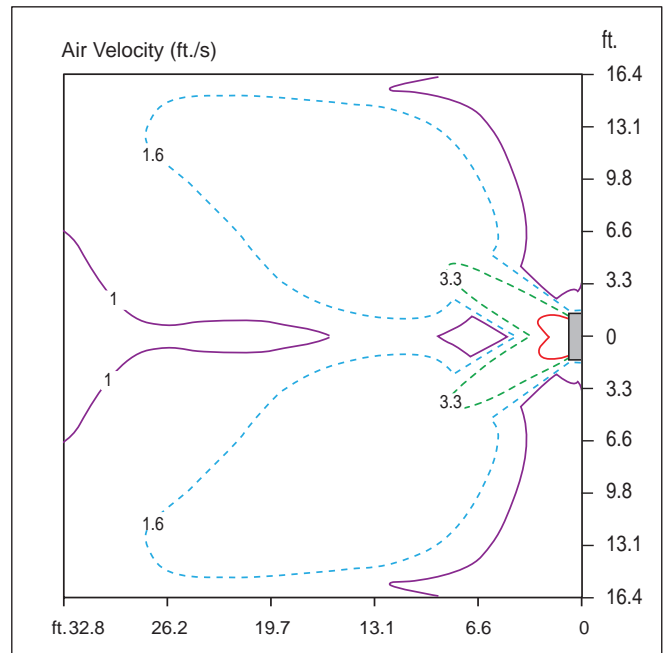

- Vertical Louver : Left and Right
- Vertical Louver Angle : 50°
- Air Speed 1 ft./s Range : 54.8 ft.
- Fan Speed : High

ART COOL MIRROR



Air Velocity / Temperature Distribution

ARNU153SJR4

Heating

Side View

Discharge angle: 55°

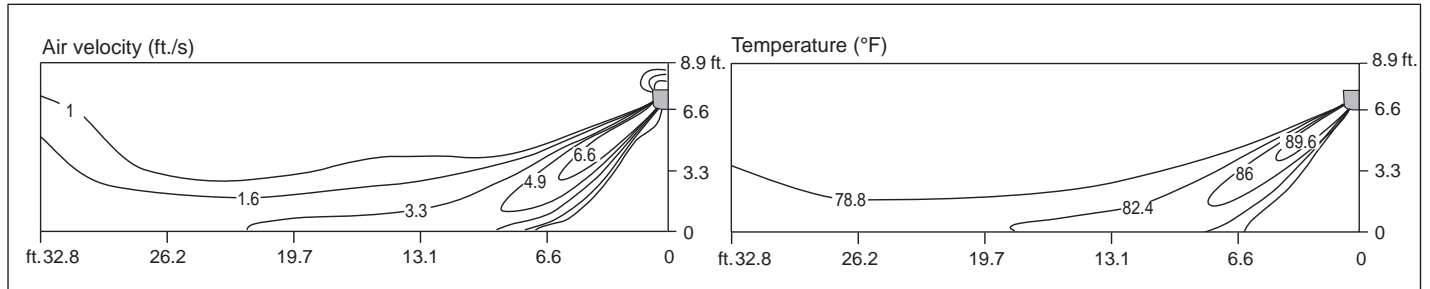

- Vertical Louver : Center
- Vertical Louver Angle : 0°
- Fan Speed : High

Top View

Discharge angle: 55°

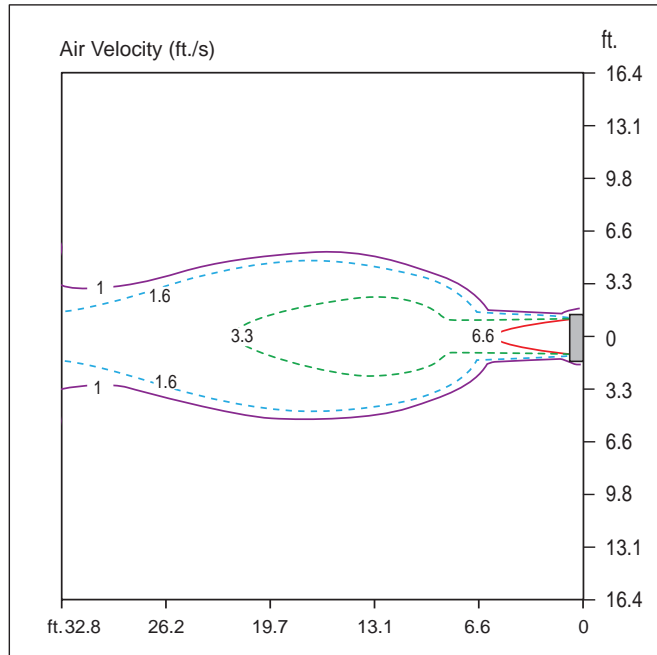

- Vertical Louver : Center
- Vertical Louver Angle : 0°
- Air Speed 1 ft./s Range : 59.1 ft.
- Fan Speed : High

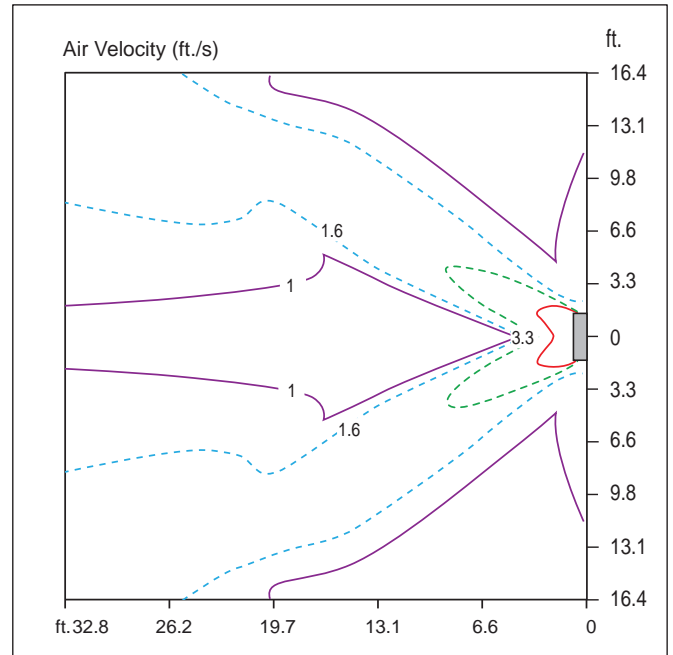

- Vertical Louver : Left and Right
- Vertical Louver Angle : 50°
- Air Speed 1 ft./s Range : 61.7 ft.
- Fan Speed : High



ARNU183SKR4

Cooling

Side View

Discharge angle: 25°

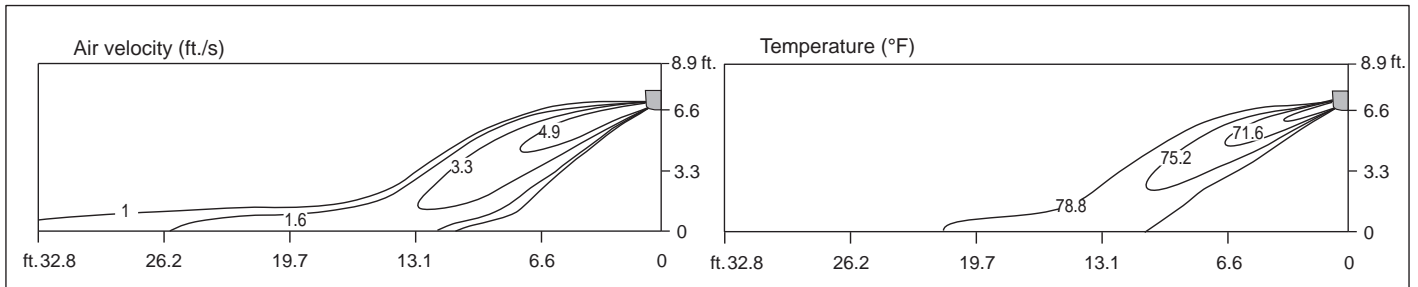

- Vertical Louver : Center
- Vertical Louver Angle : 0°
- Fan Speed : High

Top View

Discharge angle: 25°

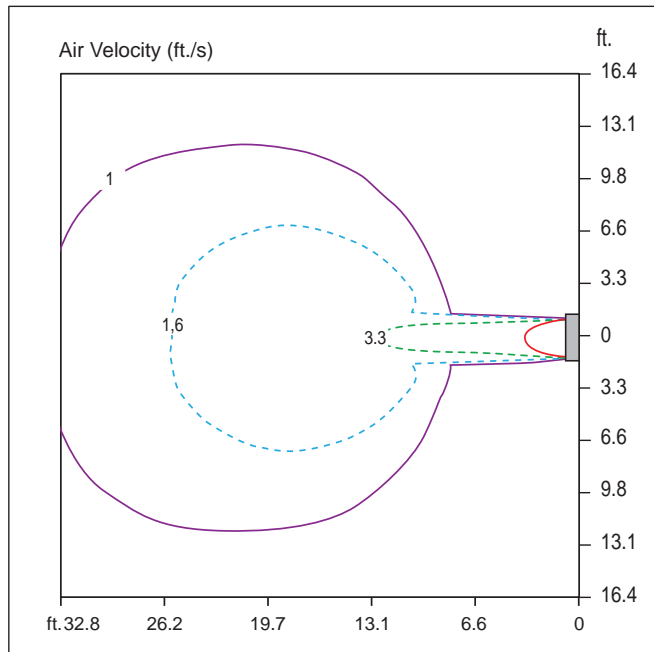

- Vertical Louver : Center
- Vertical Louver Angle : 0°
- Air Speed 1 ft./s Range : 34.1 ft.
- Fan Speed : High

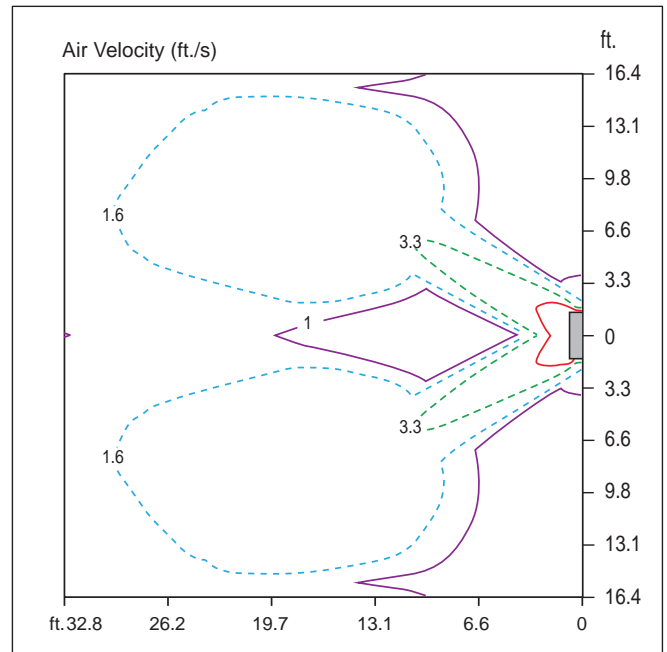

- Vertical Louver : Left and Right
- Vertical Louver Angle : 50°
- Air Speed 1 ft./s Range : 49.9 ft.
- Fan Speed : High

ART COOL MIRROR



Air Velocity / Temperature Distribution

ARNU183SKR4

Heating

Side View

Discharge angle: 45°

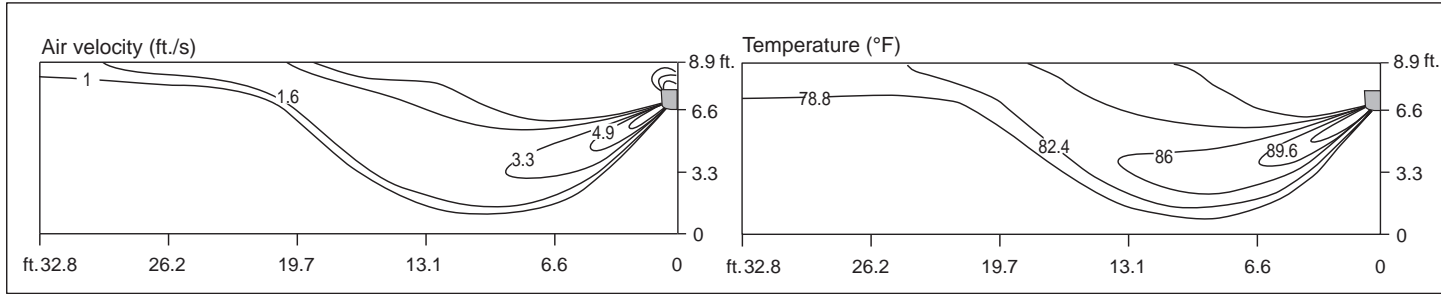

- Vertical Louver : Center
- Vertical Louver Angle : 0°
- Fan Speed : High

Top View

Discharge angle: 45°

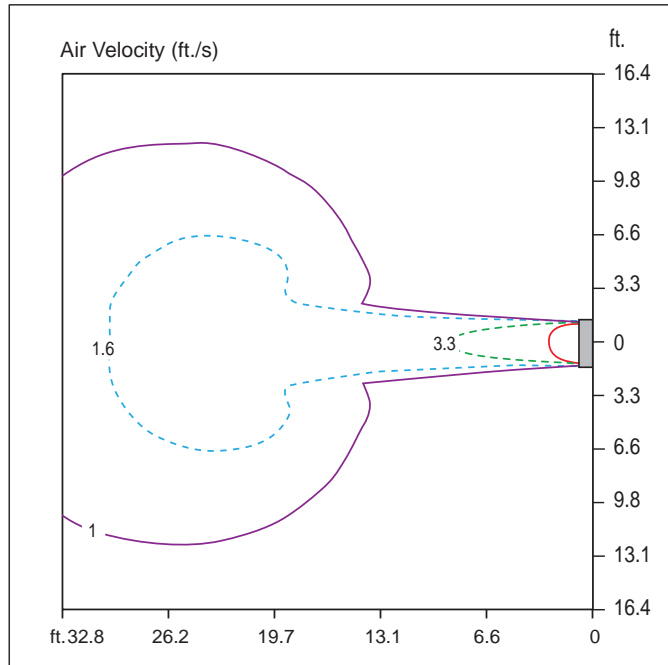

- Vertical Louver : Center
- Vertical Louver Angle : 0°
- Air Speed 1 ft./s Range : 38.1 ft.
- Fan Speed : High

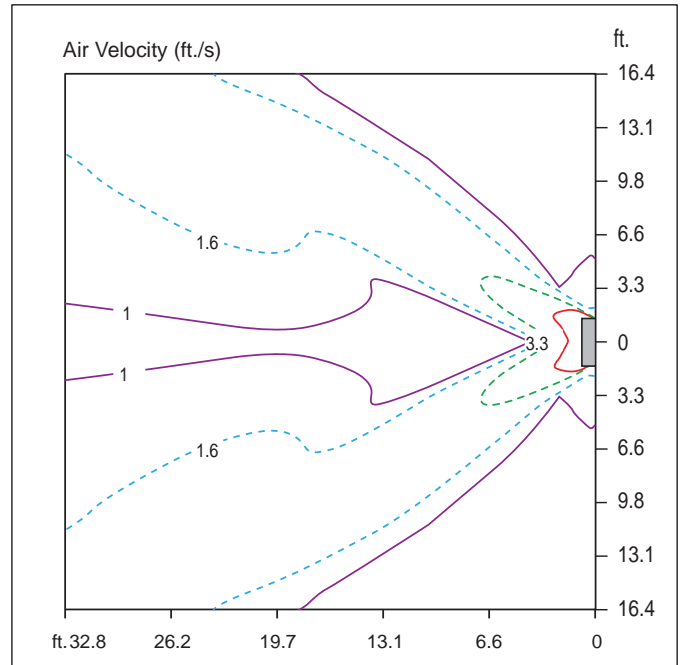

- Vertical Louver : Left and Right
- Vertical Louver Angle : 50°
- Air Speed 1 ft./s Range : 59.7 ft.
- Fan Speed : High



ARNU243SKR4

Cooling

Side View

Discharge angle: 25°

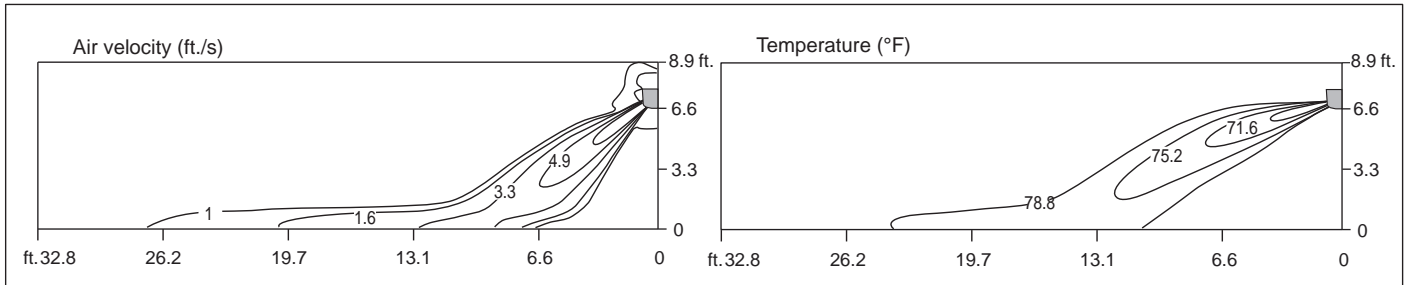

- Vertical Louver : Center
- Vertical Louver Angle : 0°
- Fan Speed : High

Top View

Discharge angle: 25°

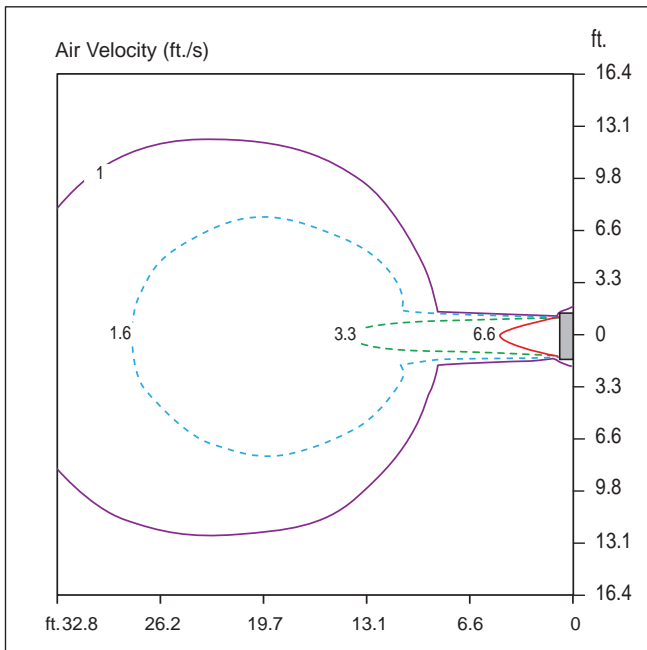

- Vertical Louver : Center
- Vertical Louver Angle : 0°
- Air Speed 1 ft./s Range : 36.7 ft.
- Fan Speed : High

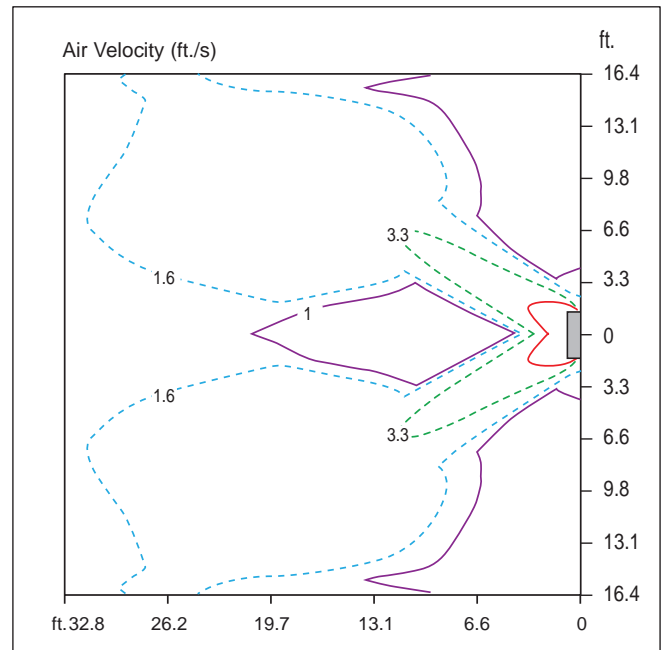

- Vertical Louver : Left and Right
- Vertical Louver Angle : 50°
- Air Speed 1 ft./s Range : 54.1 ft.
- Fan Speed : High

ART COOL MIRROR



Air Velocity / Temperature Distribution

ARNU243SKR4

Heating

Side View

Discharge angle: 45°

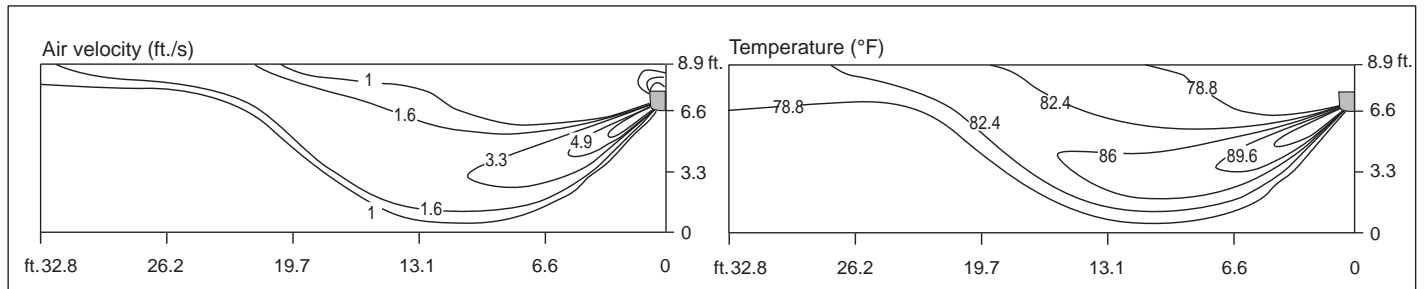

- Vertical Louver : Center
- Vertical Louver Angle : 0°
- Fan Speed : High

Top View

Discharge angle: 45°

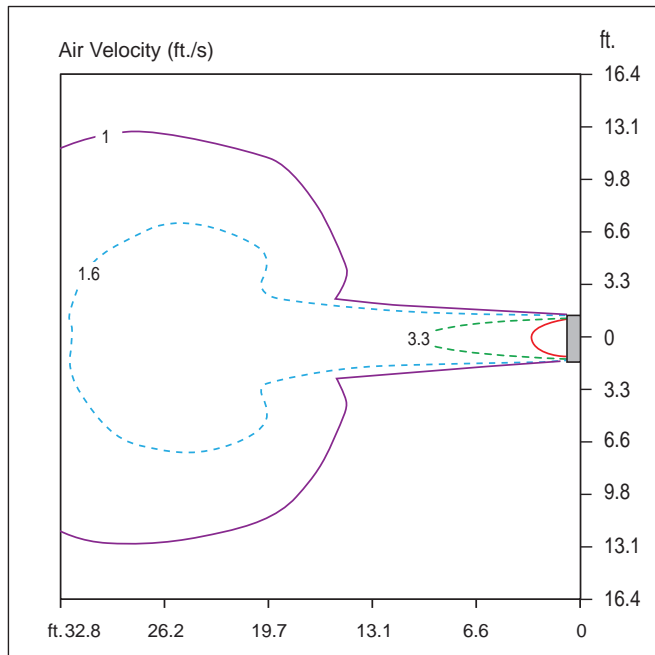

- Vertical Louver : Center
- Vertical Louver Angle : 0°
- Air Speed 1 ft./s Range : 39.7 ft.
- Fan Speed : High

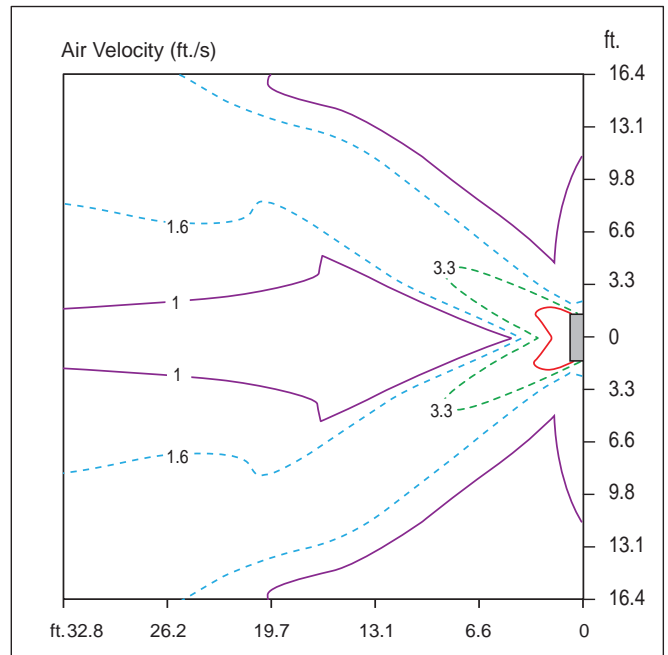

- Vertical Louver : Left and Right
- Vertical Louver Angle : 50°
- Air Speed 1 ft./s Range : 49.9 ft.
- Fan Speed : High

Table 19: ARNU053SJR4 Cooling Capacity Table.

Model No. / Capacity Index	Outdoor Air Temp. (°F DB)	Indoor Air Temperature (°F DB / WB)													
		68 / 57		73 / 61		79 / 64		80 / 67		85 / 70		88 / 73		91 / 76	
		TC	SHC	TC	SHC	TC	SHC	TC	SHC	TC	SHC	TC	SHC	TC	SHC
ARNU053SJR4/5.5	-9.9	3.6	3.7	4.4	4.3	5.0	4.6	5.5	4.9	6.2	5.3	6.6	5.2	7.1	5.2
	-5	3.6	3.7	4.4	4.3	5.0	4.6	5.5	4.9	6.2	5.3	6.6	5.2	7.1	5.2
	0	3.6	3.7	4.4	4.3	5.0	4.6	5.5	4.9	6.2	5.3	6.6	5.2	7.1	5.2
	5	3.6	3.7	4.4	4.3	5.0	4.6	5.5	4.9	6.2	5.3	6.6	5.2	7.1	5.2
	10	3.6	3.7	4.4	4.3	5.0	4.6	5.5	4.9	6.2	5.3	6.6	5.2	7.1	5.2
	14	3.6	3.7	4.4	4.3	5.0	4.6	5.5	4.9	6.2	5.3	6.6	5.2	7.1	5.2
	20	3.6	3.7	4.4	4.3	5.0	4.6	5.5	4.9	6.2	5.3	6.6	5.2	7.1	5.2
	23	3.6	3.7	4.4	4.3	5.0	4.6	5.5	4.9	6.2	5.3	6.6	5.2	7.1	5.2
	25	3.6	3.7	4.4	4.3	5.0	4.6	5.5	4.9	6.2	5.3	6.6	5.2	7.1	5.2
	30	3.6	3.7	4.4	4.3	5.0	4.6	5.5	4.9	6.2	5.3	6.6	5.2	7.1	5.2
	35	3.6	3.7	4.4	4.3	5.0	4.6	5.5	4.9	6.2	5.3	6.6	5.2	7.1	5.2
	40	3.6	3.7	4.4	4.3	5.0	4.6	5.5	4.9	6.2	5.3	6.6	5.2	7.1	5.2
	45	3.6	3.7	4.4	4.3	5.0	4.6	5.5	4.9	6.2	5.3	6.6	5.2	7.1	5.2
	50	3.6	3.7	4.4	4.3	5.0	4.6	5.5	4.9	6.2	5.3	6.6	5.2	7.1	5.2
	55	3.6	3.7	4.4	4.3	5.0	4.6	5.5	4.9	6.2	5.3	6.6	5.2	7.1	5.2
	60	3.6	3.7	4.4	4.3	5.0	4.6	5.5	4.9	6.2	5.3	6.6	5.2	7.0	5.2
	65	3.6	3.7	4.4	4.3	5.0	4.6	5.5	4.9	6.2	5.3	6.6	5.2	6.9	5.1
	70	3.6	3.7	4.4	4.3	5.0	4.6	5.5	4.9	6.2	5.3	6.6	5.2	6.8	5.0
	75	3.6	3.7	4.4	4.3	5.0	4.6	5.5	4.9	6.2	5.3	6.6	5.2	6.6	4.9
	80	3.6	3.7	4.4	4.3	5.0	4.6	5.5	4.9	6.2	5.3	6.4	5.2	6.5	4.9
	85	3.6	3.7	4.4	4.3	5.0	4.6	5.5	4.9	6.1	5.2	6.2	5.0	6.3	4.7
90	3.6	3.7	4.4	4.3	5.0	4.6	5.5	4.9	6.0	5.1	6.1	4.9	6.2	4.6	
95	3.6	3.7	4.4	4.3	5.0	4.6	5.5	4.9	5.9	5.1	6.0	4.9	6.1	4.6	
100	3.6	3.7	4.4	4.3	5.0	4.6	5.5	4.9	5.8	5.0	5.9	4.8	6.0	4.5	
105	3.6	3.7	4.2	4.1	4.7	4.4	5.3	4.7	5.5	4.7	5.7	4.6	5.8	4.4	
110	3.5	3.6	4.0	3.9	4.4	4.1	5.0	4.4	5.2	4.4	5.4	4.4	5.6	4.3	
115	3.4	3.5	3.8	3.7	4.1	3.9	4.7	4.2	4.9	4.2	5.1	4.2	5.4	4.1	
118	3.4	3.4	3.6	3.5	3.9	3.6	4.5	4.0	4.6	4.0	4.9	4.0	5.2	4.0	
122	3.3	3.3	3.4	3.3	3.7	3.4	4.2	3.8	4.4	3.8	4.6	3.8	5.0	3.8	

Art Cool™ Mirror

TC: Total Capacity (MBh); SHC: Sensible Heat Capacity (MBh).
 Cooling range with the Low Ambient Baffle Kit (sold separately) installed on the outdoor unit(s) is -9.9°F to +122°F, and is achieved only when all indoor units are operating in cooling mode. Does not impact heat recovery system synchronous operating range. The System Combination Ratio must be between 50–130%.

Rated capacity is certified under AHRI Standard 1230. Ratings are subject to change without notice.
 Current certified ratings are available at www.ahridirectory.org.
 For outdoor unit performance data, see the respective outdoor unit performance data manuals on <https://lghvac.com/commercial>.

Note:
 Low ambient performance with LGRED° heat technology is included in Multi V 5 Air Source Units produced after February 2019.

ART COOL MIRROR



Cooling Capacity Tables

ARNU073SJR4

Table 20: ARNU073SJR4 Cooling Capacity Table.

Model No. / Capacity Index	Outdoor Air Temp. (°F DB)	Indoor Air Temperature (°F DB / WB)													
		68 / 57		73 / 61		79 / 64		80 / 67		85 / 70		88 / 73		91 / 76	
		TC	SHC	TC	SHC	TC	SHC	TC	SHC	TC	SHC	TC	SHC	TC	SHC
ARNU073SJR4/ 7.5	-9.9	4.9	4.7	6.0	5.4	6.8	5.7	7.5	6.1	8.4	6.6	8.9	6.5	9.7	6.5
	-5	4.9	4.7	6.0	5.4	6.8	5.7	7.5	6.1	8.4	6.6	8.9	6.5	9.7	6.5
	0	4.9	4.7	6.0	5.4	6.8	5.7	7.5	6.1	8.4	6.6	8.9	6.5	9.7	6.5
	5	4.9	4.7	6.0	5.4	6.8	5.7	7.5	6.1	8.4	6.6	8.9	6.5	9.7	6.5
	10	4.9	4.7	6.0	5.4	6.8	5.7	7.5	6.1	8.4	6.6	8.9	6.5	9.7	6.5
	14	4.9	4.7	6.0	5.4	6.8	5.7	7.5	6.1	8.4	6.6	8.9	6.5	9.7	6.5
	20	4.9	4.7	6.0	5.4	6.8	5.7	7.5	6.1	8.4	6.6	8.9	6.5	9.7	6.5
	23	4.9	4.7	6.0	5.4	6.8	5.7	7.5	6.1	8.4	6.6	8.9	6.5	9.7	6.5
	25	4.9	4.7	6.0	5.4	6.8	5.7	7.5	6.1	8.4	6.6	8.9	6.5	9.7	6.5
	30	4.9	4.7	6.0	5.4	6.8	5.7	7.5	6.1	8.4	6.6	8.9	6.5	9.7	6.5
	35	4.9	4.7	6.0	5.4	6.8	5.7	7.5	6.1	8.4	6.6	8.9	6.5	9.7	6.5
	40	4.9	4.7	6.0	5.4	6.8	5.7	7.5	6.1	8.4	6.6	8.9	6.5	9.7	6.5
	45	4.9	4.7	6.0	5.4	6.8	5.7	7.5	6.1	8.4	6.6	8.9	6.5	9.7	6.5
	50	4.9	4.7	6.0	5.4	6.8	5.7	7.5	6.1	8.4	6.6	8.9	6.5	9.7	6.5
	55	4.9	4.7	6.0	5.4	6.8	5.7	7.5	6.1	8.4	6.6	8.9	6.5	9.7	6.5
	60	4.9	4.7	6.0	5.4	6.8	5.7	7.5	6.1	8.4	6.6	8.9	6.5	9.6	6.4
	65	4.9	4.7	6.0	5.4	6.8	5.7	7.5	6.1	8.4	6.6	8.9	6.5	9.4	6.3
	70	4.9	4.7	6.0	5.4	6.8	5.7	7.5	6.1	8.4	6.6	8.9	6.5	9.3	6.2
	75	4.9	4.7	6.0	5.4	6.8	5.7	7.5	6.1	8.4	6.6	8.9	6.5	9.1	6.1
	80	4.9	4.7	6.0	5.4	6.8	5.7	7.5	6.1	8.4	6.6	8.7	6.4	8.8	6.1
85	4.9	4.7	6.0	5.4	6.8	5.7	7.5	6.1	8.3	6.5	8.4	6.2	8.6	5.8	
90	4.9	4.7	6.0	5.4	6.8	5.7	7.5	6.1	8.2	6.4	8.3	6.1	8.4	5.8	
95	4.9	4.7	6.0	5.4	6.8	5.7	7.5	6.1	8.0	6.3	8.2	6.0	8.3	5.7	
100	4.9	4.7	6.0	5.4	6.8	5.7	7.5	6.1	7.9	6.2	8.0	6.0	8.2	5.7	
105	4.9	4.7	5.7	5.1	6.4	5.5	7.2	5.8	7.5	5.8	7.7	5.8	7.9	5.5	
110	4.8	4.5	5.4	4.8	6.0	5.1	6.8	5.5	7.1	5.5	7.3	5.5	7.7	5.4	
115	4.7	4.4	5.1	4.6	5.6	4.8	6.3	5.2	6.6	5.2	7.0	5.2	7.4	5.1	
118	4.6	4.3	4.9	4.4	5.4	4.5	6.1	5.0	6.3	5.0	6.7	5.0	7.1	4.9	
122	4.5	4.1	4.6	4.1	5.1	4.2	5.8	4.7	6.0	4.7	6.3	4.7	6.8	4.7	

MULTI V Wall-Mounted Indoor Unit Engineering Manual

TC: Total Capacity (MBh); SHC: Sensible Heat Capacity (MBh).
 Cooling range with the Low Ambient Baffle Kit (sold separately) installed on the outdoor unit(s) is -9.9°F to +122°F, and is achieved only when all indoor units are operating in cooling mode. Does not impact heat recovery system synchronous operating range.
 The System Combination Ratio must be between 50–130%.

Rated capacity is certified under AHRI Standard 1230. Ratings are subject to change without notice.
 Current certified ratings are available at www.ahridirectory.org.
 For outdoor unit performance data, see the respective outdoor unit performance data manuals on <https://lghvac.com/commercial>.

Note:

Low ambient performance with LGRED° heat technology is included in Multi V 5 Air Source Units produced after February 2019.



Table 21: ARNU093SJR4 Cooling Capacity Table.

Model No. / Capacity Index	Outdoor Air Temp. (°F DB)	Indoor Air Temperature (°F DB / WB)													
		68 / 57		73 / 61		79 / 64		80 / 67		85 / 70		88 / 73		91 / 76	
		TC	SHC	TC	SHC	TC	SHC	TC	SHC	TC	SHC	TC	SHC	TC	SHC
ARNU093SJR4 / 9.6	-9.9	6.3	5.6	7.7	6.4	8.6	6.8	9.6	7.3	10.8	7.8	11.4	7.7	12.4	7.7
	-5	6.3	5.6	7.7	6.4	8.6	6.8	9.6	7.3	10.8	7.8	11.4	7.7	12.4	7.7
	0	6.3	5.6	7.7	6.4	8.6	6.8	9.6	7.3	10.8	7.8	11.4	7.7	12.4	7.7
	5	6.3	5.6	7.7	6.4	8.6	6.8	9.6	7.3	10.8	7.8	11.4	7.7	12.4	7.7
	10	6.3	5.6	7.7	6.4	8.6	6.8	9.6	7.3	10.8	7.8	11.4	7.7	12.4	7.7
	14	6.3	5.6	7.7	6.4	8.6	6.8	9.6	7.3	10.8	7.8	11.4	7.7	12.4	7.7
	20	6.3	5.6	7.7	6.4	8.6	6.8	9.6	7.3	10.8	7.8	11.4	7.7	12.4	7.7
	23	6.3	5.6	7.7	6.4	8.6	6.8	9.6	7.3	10.8	7.8	11.4	7.7	12.4	7.7
	25	6.3	5.6	7.7	6.4	8.6	6.8	9.6	7.3	10.8	7.8	11.4	7.7	12.4	7.7
	30	6.3	5.6	7.7	6.4	8.6	6.8	9.6	7.3	10.8	7.8	11.4	7.7	12.4	7.7
	35	6.3	5.6	7.7	6.4	8.6	6.8	9.6	7.3	10.8	7.8	11.4	7.7	12.4	7.7
	40	6.3	5.6	7.7	6.4	8.6	6.8	9.6	7.3	10.8	7.8	11.4	7.7	12.4	7.7
	45	6.3	5.6	7.7	6.4	8.6	6.8	9.6	7.3	10.8	7.8	11.4	7.7	12.4	7.7
	50	6.3	5.6	7.7	6.4	8.6	6.8	9.6	7.3	10.8	7.8	11.4	7.7	12.4	7.7
	55	6.3	5.6	7.7	6.4	8.6	6.8	9.6	7.3	10.8	7.8	11.4	7.7	12.4	7.7
	60	6.3	5.6	7.7	6.4	8.6	6.8	9.6	7.3	10.8	7.8	11.4	7.7	12.3	7.7
	65	6.3	5.6	7.7	6.4	8.6	6.8	9.6	7.3	10.8	7.8	11.4	7.7	12.1	7.6
	70	6.3	5.6	7.7	6.4	8.6	6.8	9.6	7.3	10.8	7.8	11.4	7.7	11.9	7.4
	75	6.3	5.6	7.7	6.4	8.6	6.8	9.6	7.3	10.8	7.8	11.4	7.7	11.6	7.3
	80	6.3	5.6	7.7	6.4	8.6	6.8	9.6	7.3	10.8	7.8	11.1	7.7	11.3	7.2
85	6.3	5.6	7.7	6.4	8.6	6.8	9.6	7.3	10.6	7.7	10.8	7.4	11.0	6.9	
90	6.3	5.6	7.7	6.4	8.6	6.8	9.6	7.3	10.5	7.6	10.6	7.2	10.8	6.9	
95	6.3	5.6	7.7	6.4	8.6	6.8	9.6	7.3	10.3	7.6	10.5	7.2	10.6	6.8	
100	6.3	5.6	7.7	6.4	8.6	6.8	9.6	7.3	10.1	7.4	10.3	7.1	10.5	6.7	
105	6.3	5.6	7.3	6.1	8.2	6.5	9.2	6.9	9.6	6.9	9.9	6.9	10.2	6.6	
110	6.2	5.4	6.9	5.8	7.7	6.1	8.6	6.5	9.0	6.5	9.4	6.5	9.8	6.4	
115	6.0	5.2	6.6	5.5	7.2	5.7	8.1	6.2	8.5	6.2	8.9	6.2	9.4	6.1	
118	5.9	5.1	6.2	5.2	6.9	5.4	7.8	5.9	8.1	5.9	8.5	5.9	9.0	5.9	
122	5.7	4.9	5.9	4.9	6.5	5.1	7.4	5.6	7.7	5.6	8.1	5.6	8.7	5.6	

Art Cool™ Mirror

TC: Total Capacity (MBh); SHC: Sensible Heat Capacity (MBh).
 Cooling range with the Low Ambient Baffle Kit (sold separately) installed on the outdoor unit(s) is -9.9°F to +122°F, and is achieved only when all indoor units are operating in cooling mode. Does not impact heat recovery system synchronous operating range.
 The System Combination Ratio must be between 50-130%.

Rated capacity is certified under AHRI Standard 1230. Ratings are subject to change without notice.
 Current certified ratings are available at www.ahridirectory.org.
 For outdoor unit performance data, see the respective outdoor unit performance data manuals on <https://lghvac.com/commercial>.

Note:

Low ambient performance with LGRED° heat technology is included in Multi V 5 Air Source Units produced after February 2019.

ART COOL MIRROR



Cooling Capacity Tables

ARNU123SJR4

Table 22: ARNU123SJR4 Cooling Capacity Table.

Model No. / Capacity Index	Outdoor Air Temp. (°F DB)	Indoor Air Temperature (°F DB / WB)													
		68 / 57		73 / 61		79 / 64		80 / 67		85 / 70		88 / 73		91 / 76	
		TC	SHC	TC	SHC	TC	SHC	TC	SHC	TC	SHC	TC	SHC	TC	SHC
ARNU123SJR4/12.3	-9.9	8.1	6.7	9.8	7.7	11.1	8.2	12.3	8.7	13.8	9.4	14.7	9.3	15.9	9.3
	-5	8.1	6.7	9.8	7.7	11.1	8.2	12.3	8.7	13.8	9.4	14.7	9.3	15.9	9.3
	0	8.1	6.7	9.8	7.7	11.1	8.2	12.3	8.7	13.8	9.4	14.7	9.3	15.9	9.3
	5	8.1	6.7	9.8	7.7	11.1	8.2	12.3	8.7	13.8	9.4	14.7	9.3	15.9	9.3
	10	8.1	6.7	9.8	7.7	11.1	8.2	12.3	8.7	13.8	9.4	14.7	9.3	15.9	9.3
	14	8.1	6.7	9.8	7.7	11.1	8.2	12.3	8.7	13.8	9.4	14.7	9.3	15.9	9.3
	20	8.1	6.7	9.8	7.7	11.1	8.2	12.3	8.7	13.8	9.4	14.7	9.3	15.9	9.3
	23	8.1	6.7	9.8	7.7	11.1	8.2	12.3	8.7	13.8	9.4	14.7	9.3	15.9	9.3
	25	8.1	6.7	9.8	7.7	11.1	8.2	12.3	8.7	13.8	9.4	14.7	9.3	15.9	9.3
	30	8.1	6.7	9.8	7.7	11.1	8.2	12.3	8.7	13.8	9.4	14.7	9.3	15.9	9.3
	35	8.1	6.7	9.8	7.7	11.1	8.2	12.3	8.7	13.8	9.4	14.7	9.3	15.9	9.3
	40	8.1	6.7	9.8	7.7	11.1	8.2	12.3	8.7	13.8	9.4	14.7	9.3	15.9	9.3
	45	8.1	6.7	9.8	7.7	11.1	8.2	12.3	8.7	13.8	9.4	14.7	9.3	15.9	9.3
	50	8.1	6.7	9.8	7.7	11.1	8.2	12.3	8.7	13.8	9.4	14.7	9.3	15.9	9.3
	55	8.1	6.7	9.8	7.7	11.1	8.2	12.3	8.7	13.8	9.4	14.7	9.3	15.9	9.3
	60	8.1	6.7	9.8	7.7	11.1	8.2	12.3	8.7	13.8	9.4	14.7	9.3	15.7	9.2
	65	8.1	6.7	9.8	7.7	11.1	8.2	12.3	8.7	13.8	9.4	14.7	9.3	15.5	9.1
	70	8.1	6.7	9.8	7.7	11.1	8.2	12.3	8.7	13.8	9.4	14.7	9.3	15.3	8.9
	75	8.1	6.7	9.8	7.7	11.1	8.2	12.3	8.7	13.8	9.4	14.7	9.3	14.9	8.7
	80	8.1	6.7	9.8	7.7	11.1	8.2	12.3	8.7	13.8	9.4	14.2	9.2	14.5	8.7
85	8.1	6.7	9.8	7.7	11.1	8.2	12.3	8.7	13.6	9.3	13.8	8.8	14.0	8.4	
90	8.1	6.7	9.8	7.7	11.1	8.2	12.3	8.7	13.4	9.1	13.5	8.7	13.8	8.3	
95	8.1	6.7	9.8	7.7	11.1	8.2	12.3	8.7	13.2	9.1	13.4	8.6	13.6	8.2	
100	8.1	6.7	9.8	7.7	11.1	8.2	12.3	8.7	12.9	8.9	13.2	8.5	13.4	8.1	
105	8.1	6.7	9.3	7.3	10.6	7.9	11.8	8.4	12.3	8.4	12.7	8.3	13.0	7.9	
110	7.9	6.5	8.9	6.9	9.8	7.3	11.1	7.9	11.6	7.9	12.0	7.9	12.6	7.7	
115	7.7	6.3	8.4	6.6	9.2	6.9	10.4	7.5	10.9	7.5	11.4	7.5	12.1	7.4	
118	7.5	6.1	8.0	6.2	8.8	6.5	10.0	7.1	10.4	7.1	10.9	7.1	11.6	7.1	
122	7.3	5.9	7.6	5.9	8.3	6.1	9.4	6.7	9.8	6.7	10.3	6.7	11.1	6.7	

TC: Total Capacity (MBh); SHC: Sensible Heat Capacity (MBh).
 Cooling range with the Low Ambient Baffle Kit (sold separately) installed on the outdoor unit(s) is -9.9°F to +122°F, and is achieved only when all indoor units are operating in cooling mode. Does not impact heat recovery system synchronous operating range.
 The System Combination Ratio must be between 50–130%.

Rated capacity is certified under AHRI Standard 1230. Ratings are subject to change without notice.
 Current certified ratings are available at www.ahrirectory.org.
 For outdoor unit performance data, see the respective outdoor unit performance data manuals on <https://lghvac.com/commercial>.

Note:

Low ambient performance with LGRED° heat technology is included in Multi V 5 Air Source Units produced after February 2019.



Table 23: ARNU153SJR4 Cooling Capacity Table.

Model No. / Capacity Index	Outdoor Air Temp. (°F DB)	Indoor Air Temperature (°F DB / WB)													
		68 / 57		73 / 61		79 / 64		80 / 67		85 / 70		88 / 73		91 / 76	
		TC	SHC	TC	SHC	TC	SHC	TC	SHC	TC	SHC	TC	SHC	TC	SHC
ARNU153SJR4/ 15.4	-9.9	10.1	8.4	12.3	9.7	13.9	10.4	15.4	11.0	17.3	11.8	18.4	11.7	19.9	11.7
	-5	10.1	8.4	12.3	9.7	13.9	10.4	15.4	11.0	17.3	11.8	18.4	11.7	19.9	11.7
	0	10.1	8.4	12.3	9.7	13.9	10.4	15.4	11.0	17.3	11.8	18.4	11.7	19.9	11.7
	5	10.1	8.4	12.3	9.7	13.9	10.4	15.4	11.0	17.3	11.8	18.4	11.7	19.9	11.7
	10	10.1	8.4	12.3	9.7	13.9	10.4	15.4	11.0	17.3	11.8	18.4	11.7	19.9	11.7
	14	10.1	8.4	12.3	9.7	13.9	10.4	15.4	11.0	17.3	11.8	18.4	11.7	19.9	11.7
	20	10.1	8.4	12.3	9.7	13.9	10.4	15.4	11.0	17.3	11.8	18.4	11.7	19.9	11.7
	23	10.1	8.4	12.3	9.7	13.9	10.4	15.4	11.0	17.3	11.8	18.4	11.7	19.9	11.7
	25	10.1	8.4	12.3	9.7	13.9	10.4	15.4	11.0	17.3	11.8	18.4	11.7	19.9	11.7
	30	10.1	8.4	12.3	9.7	13.9	10.4	15.4	11.0	17.3	11.8	18.4	11.7	19.9	11.7
	35	10.1	8.4	12.3	9.7	13.9	10.4	15.4	11.0	17.3	11.8	18.4	11.7	19.9	11.7
	40	10.1	8.4	12.3	9.7	13.9	10.4	15.4	11.0	17.3	11.8	18.4	11.7	19.9	11.7
	45	10.1	8.4	12.3	9.7	13.9	10.4	15.4	11.0	17.3	11.8	18.4	11.7	19.9	11.7
	50	10.1	8.4	12.3	9.7	13.9	10.4	15.4	11.0	17.3	11.8	18.4	11.7	19.9	11.7
	55	10.1	8.4	12.3	9.7	13.9	10.4	15.4	11.0	17.3	11.8	18.4	11.7	19.9	11.7
	60	10.1	8.4	12.3	9.7	13.9	10.4	15.4	11.0	17.3	11.8	18.4	11.7	19.7	11.7
	65	10.1	8.4	12.3	9.7	13.9	10.4	15.4	11.0	17.3	11.8	18.4	11.7	19.4	11.5
	70	10.1	8.4	12.3	9.7	13.9	10.4	15.4	11.0	17.3	11.8	18.4	11.7	19.1	11.3
	75	10.1	8.4	12.3	9.7	13.9	10.4	15.4	11.0	17.3	11.8	18.4	11.7	18.6	11.0
	80	10.1	8.4	12.3	9.7	13.9	10.4	15.4	11.0	17.3	11.8	17.8	11.7	18.2	11.0
85	10.1	8.4	12.3	9.7	13.9	10.4	15.4	11.0	17.1	11.7	17.3	11.2	17.6	10.5	
90	10.1	8.4	12.3	9.7	13.9	10.4	15.4	11.0	16.8	11.5	16.9	11.0	17.3	10.4	
95	10.1	8.4	12.3	9.7	13.9	10.4	15.4	11.0	16.5	11.5	16.8	10.9	17.1	10.3	
100	10.1	8.4	12.3	9.7	13.9	10.4	15.4	11.0	16.2	11.3	16.5	10.8	16.8	10.2	
105	10.1	8.4	11.7	9.2	13.2	9.9	14.8	10.5	15.4	10.5	15.8	10.4	16.3	10.0	
110	9.9	8.2	11.1	8.7	12.3	9.2	13.9	9.9	14.5	9.9	15.1	9.9	15.7	9.7	
115	9.6	8.0	10.5	8.3	11.6	8.7	13.0	9.4	13.6	9.4	14.3	9.4	15.1	9.3	
118	9.4	7.7	10.0	7.9	11.0	8.2	12.5	9.0	13.0	9.0	13.7	9.0	14.5	8.9	
122	9.1	7.5	9.5	7.5	10.4	7.7	11.8	8.5	12.3	8.5	12.9	8.5	13.9	8.5	

Art Cool™ Mirror

TC: Total Capacity (MBh); SHC: Sensible Heat Capacity (MBh).
Cooling range with the Low Ambient Baffle Kit (sold separately) installed on the outdoor unit(s) is -9.9°F to +122°F, and is achieved only when all indoor units are operating in cooling mode. Does not impact heat recovery system synchronous operating range. The System Combination Ratio must be between 50–130%.

Rated capacity is certified under AHRI Standard 1230. Ratings are subject to change without notice.
Current certified ratings are available at www.ahridirectory.org.
For outdoor unit performance data, see the respective outdoor unit performance data manuals on <https://lghvac.com/commercial>.

Note:
Low ambient performance with LGRED° heat technology is included in Multi V 5 Air Source Units produced after February 2019.

ART COOL MIRROR



Cooling Capacity Tables

ARNU183SKR4

Table 24: ARNU183SKR4 Cooling Capacity Table.

Model No. / Capacity Index	Outdoor Air Temp. (°F DB)	Indoor Air Temperature (°F DB / WB)													
		68 / 57		73 / 61		79 / 64		80 / 67		85 / 70		88 / 73		91 / 76	
		TC	SHC	TC	SHC	TC	SHC	TC	SHC	TC	SHC	TC	SHC	TC	SHC
ARNU183SKR4/ 19.1	-9.9	12.6	10.4	15.3	12.0	17.2	12.7	19.1	13.6	21.4	14.6	22.8	14.4	24.7	14.4
	-5	12.6	10.4	15.3	12.0	17.2	12.7	19.1	13.6	21.4	14.6	22.8	14.4	24.7	14.4
	0	12.6	10.4	15.3	12.0	17.2	12.7	19.1	13.6	21.4	14.6	22.8	14.4	24.7	14.4
	5	12.6	10.4	15.3	12.0	17.2	12.7	19.1	13.6	21.4	14.6	22.8	14.4	24.7	14.4
	10	12.6	10.4	15.3	12.0	17.2	12.7	19.1	13.6	21.4	14.6	22.8	14.4	24.7	14.4
	14	12.6	10.4	15.3	12.0	17.2	12.7	19.1	13.6	21.4	14.6	22.8	14.4	24.7	14.4
	20	12.6	10.4	15.3	12.0	17.2	12.7	19.1	13.6	21.4	14.6	22.8	14.4	24.7	14.4
	23	12.6	10.4	15.3	12.0	17.2	12.7	19.1	13.6	21.4	14.6	22.8	14.4	24.7	14.4
	25	12.6	10.4	15.3	12.0	17.2	12.7	19.1	13.6	21.4	14.6	22.8	14.4	24.7	14.4
	30	12.6	10.4	15.3	12.0	17.2	12.7	19.1	13.6	21.4	14.6	22.8	14.4	24.7	14.4
	35	12.6	10.4	15.3	12.0	17.2	12.7	19.1	13.6	21.4	14.6	22.8	14.4	24.7	14.4
	40	12.6	10.4	15.3	12.0	17.2	12.7	19.1	13.6	21.4	14.6	22.8	14.4	24.7	14.4
	45	12.6	10.4	15.3	12.0	17.2	12.7	19.1	13.6	21.4	14.6	22.8	14.4	24.7	14.4
	50	12.6	10.4	15.3	12.0	17.2	12.7	19.1	13.6	21.4	14.6	22.8	14.4	24.7	14.4
	55	12.6	10.4	15.3	12.0	17.2	12.7	19.1	13.6	21.4	14.6	22.8	14.4	24.7	14.4
	60	12.6	10.4	15.3	12.0	17.2	12.7	19.1	13.6	21.4	14.6	22.8	14.4	24.4	14.3
	65	12.6	10.4	15.3	12.0	17.2	12.7	19.1	13.6	21.4	14.6	22.8	14.4	24.0	14.1
	70	12.6	10.4	15.3	12.0	17.2	12.7	19.1	13.6	21.4	14.6	22.8	14.4	23.7	13.9
	75	12.6	10.4	15.3	12.0	17.2	12.7	19.1	13.6	21.4	14.6	22.8	14.4	23.1	13.6
	80	12.6	10.4	15.3	12.0	17.2	12.7	19.1	13.6	21.4	14.6	22.1	14.3	22.5	13.5
85	12.6	10.4	15.3	12.0	17.2	12.7	19.1	13.6	21.2	14.4	21.4	13.7	21.8	13.0	
90	12.6	10.4	15.3	12.0	17.2	12.7	19.1	13.6	20.9	14.2	21.0	13.5	21.4	12.8	
95	12.6	10.4	15.3	12.0	17.2	12.7	19.1	13.6	20.5	14.1	20.9	13.4	21.2	12.6	
100	12.6	10.4	15.3	12.0	17.2	12.7	19.1	13.6	20.1	13.9	20.5	13.3	20.9	12.6	
105	12.6	10.4	14.5	11.4	16.4	12.2	18.3	13.0	19.0	13.0	19.7	12.8	20.2	12.3	
110	12.3	10.1	13.8	10.7	15.3	11.4	17.2	12.2	18.0	12.2	18.7	12.2	19.5	11.9	
115	12.0	9.8	13.1	10.2	14.4	10.7	16.2	11.6	16.9	11.6	17.8	11.6	18.7	11.4	
118	11.7	9.5	12.4	9.7	13.6	10.0	15.5	11.0	16.1	11.0	17.0	11.0	18.0	10.9	
122	11.3	9.2	11.8	9.2	12.9	9.4	14.7	10.4	15.3	10.4	16.0	10.4	17.2	10.4	

TC: Total Capacity (MBh); SHC: Sensible Heat Capacity (MBh).
 Cooling range with the Low Ambient Baffle Kit (sold separately) installed on the outdoor unit(s) is -9.9°F to +122°F, and is achieved only when all indoor units are operating in cooling mode. Does not impact heat recovery system synchronous operating range.
 The System Combination Ratio must be between 50–130%.

Rated capacity is certified under AHRI Standard 1230. Ratings are subject to change without notice.
 Current certified ratings are available at www.ahrirectory.org.
 For outdoor unit performance data, see the respective outdoor unit performance data manuals on <https://lghvac.com/commercial>.

Note:

Low ambient performance with LGRED° heat technology is included in Multi V 5 Air Source Units produced after February 2019.



Table 25: ARNU243SKR4 Cooling Capacity Table.

Model No. / Capacity Index	Outdoor Air Temp. (°F DB)	Indoor Air Temperature (°F DB / WB)													
		68 / 57		73 / 61		79 / 64		80 / 67		85 / 70		88 / 73		91 / 76	
		TC	SHC	TC	SHC	TC	SHC	TC	SHC	TC	SHC	TC	SHC	TC	SHC
ARNU243SKR4/ 24.2	-9.9	15.9	13.0	19.4	15.0	21.8	15.9	24.2	17.0	27.1	18.2	28.8	18.0	31.3	18.0
	-5	15.9	13.0	19.4	15.0	21.8	15.9	24.2	17.0	27.1	18.2	28.8	18.0	31.3	18.0
	0	15.9	13.0	19.4	15.0	21.8	15.9	24.2	17.0	27.1	18.2	28.8	18.0	31.3	18.0
	5	15.9	13.0	19.4	15.0	21.8	15.9	24.2	17.0	27.1	18.2	28.8	18.0	31.3	18.0
	10	15.9	13.0	19.4	15.0	21.8	15.9	24.2	17.0	27.1	18.2	28.8	18.0	31.3	18.0
	14	15.9	13.0	19.4	15.0	21.8	15.9	24.2	17.0	27.1	18.2	28.8	18.0	31.3	18.0
	20	15.9	13.0	19.4	15.0	21.8	15.9	24.2	17.0	27.1	18.2	28.8	18.0	31.3	18.0
	23	15.9	13.0	19.4	15.0	21.8	15.9	24.2	17.0	27.1	18.2	28.8	18.0	31.3	18.0
	25	15.9	13.0	19.4	15.0	21.8	15.9	24.2	17.0	27.1	18.2	28.8	18.0	31.3	18.0
	30	15.9	13.0	19.4	15.0	21.8	15.9	24.2	17.0	27.1	18.2	28.8	18.0	31.3	18.0
	35	15.9	13.0	19.4	15.0	21.8	15.9	24.2	17.0	27.1	18.2	28.8	18.0	31.3	18.0
	40	15.9	13.0	19.4	15.0	21.8	15.9	24.2	17.0	27.1	18.2	28.8	18.0	31.3	18.0
	45	15.9	13.0	19.4	15.0	21.8	15.9	24.2	17.0	27.1	18.2	28.8	18.0	31.3	18.0
	50	15.9	13.0	19.4	15.0	21.8	15.9	24.2	17.0	27.1	18.2	28.8	18.0	31.3	18.0
	55	15.9	13.0	19.4	15.0	21.8	15.9	24.2	17.0	27.1	18.2	28.8	18.0	31.3	18.0
	60	15.9	13.0	19.4	15.0	21.8	15.9	24.2	17.0	27.1	18.2	28.8	18.0	31.0	17.9
	65	15.9	13.0	19.4	15.0	21.8	15.9	24.2	17.0	27.1	18.2	28.8	18.0	30.5	17.7
	70	15.9	13.0	19.4	15.0	21.8	15.9	24.2	17.0	27.1	18.2	28.8	18.0	30.0	17.4
	75	15.9	13.0	19.4	15.0	21.8	15.9	24.2	17.0	27.1	18.2	28.8	18.0	29.2	17.0
	80	15.9	13.0	19.4	15.0	21.8	15.9	24.2	17.0	27.1	18.2	28.0	17.9	28.5	16.9
85	15.9	13.0	19.4	15.0	21.8	15.9	24.2	17.0	26.8	18.0	27.1	17.2	27.6	16.2	
90	15.9	13.0	19.4	15.0	21.8	15.9	24.2	17.0	26.4	17.8	26.6	16.9	27.1	16.0	
95	15.9	13.0	19.4	15.0	21.8	15.9	24.2	17.0	25.9	17.7	26.4	16.8	26.8	15.8	
100	15.9	13.0	19.4	15.0	21.8	15.9	24.2	17.0	25.4	17.4	25.9	16.6	26.4	15.7	
105	15.9	13.0	18.4	14.2	20.8	15.3	23.2	16.2	24.1	16.2	24.9	16.0	25.6	15.4	
110	15.5	12.6	17.4	13.5	19.4	14.2	21.8	15.3	22.8	15.3	23.7	15.3	24.7	14.9	
115	15.1	12.2	16.6	12.8	18.2	13.4	20.5	14.5	21.4	14.5	22.5	14.5	23.7	14.3	
118	14.8	11.9	15.7	12.1	17.3	12.6	19.7	13.8	20.4	13.8	21.5	13.8	22.8	13.7	
122	14.4	11.5	15.0	11.5	16.3	11.8	18.6	13.1	19.4	13.1	20.3	13.1	21.9	13.1	

Art Cool™ Mirror

TC: Total Capacity (MBh); SHC: Sensible Heat Capacity (MBh).
 Cooling range with the Low Ambient Baffle Kit (sold separately) installed on the outdoor unit(s) is -9.9°F to +122°F, and is achieved only when all indoor units are operating in cooling mode. Does not impact heat recovery system synchronous operating range.
 The System Combination Ratio must be between 50–130%.

Rated capacity is certified under AHRI Standard 1230. Ratings are subject to change without notice.
 Current certified ratings are available at www.ahridirectory.org.
 For outdoor unit performance data, see the respective outdoor unit performance data manuals on <https://lghvac.com/commercial>.

Note:

Low ambient performance with LGRED° heat technology is included in Multi V 5 Air Source Units produced after February 2019.

ART COOL MIRROR



Heating Capacity Tables

ARNU053SJR4

Table 26: ARNU053SJR4 Heating Capacity Table.

Model No. / Capacity Index	Outdoor Air Temp.		Indoor Air Temperature (°F DB)							
			59	61	64	67	70	73	76	80
	°F DB	°F WB	TC	TC	TC	TC	TC	TC	TC	TC
MBh			MBh	MBh	MBh	MBh	MBh	MBh	MBh	MBh
ARNU053SJR4/ 5.5	-21.6	-22.0	3.1	3.1	3.1	3.1	3.1	3.1	3.1	3.1
	-17.1	-17.5	3.5	3.5	3.5	3.5	3.4	3.4	3.4	3.4
	-12.6	-13	3.8	3.8	3.8	3.8	3.8	3.8	3.8	3.8
	-7	-7.6	4.0	4.0	4.0	4.0	3.9	3.9	3.9	3.9
	-4	-4.4	4.1	4.1	4.1	4.1	4.0	4.0	4.0	4.0
	0	-0.4	4.2	4.2	4.2	4.2	4.2	4.2	4.2	4.2
	5	4.5	4.8	4.7	4.6	4.6	4.6	4.6	4.6	4.6
	10	9	4.9	4.9	4.9	4.9	4.9	4.9	4.9	4.9
	15	14	5.3	5.3	5.3	5.3	5.3	5.3	5.2	5.1
	20	19	5.6	5.6	5.6	5.6	5.4	5.4	5.3	5.3
	25	23	5.8	5.8	5.8	5.8	5.8	5.7	5.6	5.3
	30	28	5.9	5.9	5.9	5.9	5.9	5.8	5.6	5.3
	35	32	6.1	6.1	6.1	6.1	6.0	5.9	5.6	5.3
	40	36	6.3	6.3	6.3	6.3	6.1	5.9	5.6	5.3
	45	41	6.6	6.6	6.6	6.4	6.1	5.9	5.6	5.3
	47	43	6.8	6.8	6.7	6.4	6.1	5.9	5.6	5.3
50	46	7.3	7.0	6.7	6.4	6.1	5.9	5.6	5.3	
55	51	7.5	7.1	6.7	6.4	6.1	5.9	5.6	5.3	
60	56	7.5	7.1	6.7	6.4	6.1	5.9	5.6	5.3	

TC: Total Capacity (MBh).

The System Combination Ratio must be between 50–130%.

Rated capacity is certified under AHRI Standard 1230. Ratings are subject to change without notice.

Current certified ratings are available at www.ahridirectory.org.

For outdoor unit performance data, see the respective outdoor unit performance data manuals on <https://lghvac.com/commercial>.

Note:

Low ambient performance with LGRED° heat technology is included in Multi V 5 Air Source Units produced after February 2019.



Table 27: ARNU073SJR4 Heating Capacity Table.

Model No. / Capacity Index	Outdoor Air Temp.		Indoor Air Temperature (°F DB)							
			59	61	64	67	70	73	76	80
	°F DB	°F WB	TC MBh	TC MBh	TC MBh	TC MBh	TC MBh	TC MBh	TC MBh	TC MBh
ARNU073SJR4/ 7.5	-21.6	-22.0	4.3	4.3	4.3	4.3	4.3	4.3	4.3	4.3
	-17.1	-17.5	4.8	4.8	4.8	4.8	4.8	4.8	4.8	4.8
	-12.6	-13	5.4	5.4	5.4	5.4	5.3	5.3	5.3	5.3
	-7	-7.6	5.5	5.5	5.5	5.5	5.4	5.4	5.4	5.4
	-4	-4.4	5.7	5.7	5.7	5.7	5.6	5.6	5.6	5.6
	0	-0.4	5.9	5.9	5.9	5.9	5.9	5.8	5.8	5.8
	5	4.5	6.6	6.6	6.5	6.5	6.5	6.5	6.5	6.5
	10	9	6.9	6.9	6.9	6.8	6.8	6.8	6.8	6.8
	15	14	7.3	7.3	7.3	7.3	7.3	7.3	7.2	7.1
	20	19	7.7	7.7	7.7	7.7	7.6	7.6	7.4	7.4
	25	23	8.1	8.1	8.1	8.1	8.1	7.9	7.8	7.4
	30	28	8.3	8.3	8.3	8.3	8.3	8.1	7.8	7.4
	35	32	8.5	8.5	8.5	8.5	8.4	8.3	7.8	7.4
	40	36	8.8	8.8	8.8	8.8	8.5	8.3	7.8	7.4
	45	41	9.2	9.2	9.2	8.9	8.5	8.3	7.8	7.4
	47	43	9.5	9.4	9.4	8.9	8.5	8.3	7.8	7.4
50	46	10.2	9.8	9.4	8.9	8.5	8.3	7.8	7.4	
55	51	10.4	9.9	9.4	8.9	8.5	8.3	7.8	7.4	
60	56	10.4	9.9	9.4	8.9	8.5	8.3	7.8	7.4	

TC: Total Capacity (MBh).
 The System Combination Ratio must be between 50–130%.
 Rated capacity is certified under AHRI Standard 1230. Ratings are subject to change without notice.

Current certified ratings are available at www.ahridirectory.org.
 For outdoor unit performance data, see the respective outdoor unit performance data manuals on <https://lghvac.com/commercial>.

Note:

Low ambient performance with LGRED° heat technology is included in Multi V 5 Air Source Units produced after February 2019.

ART COOL MIRROR



Heating Capacity Tables

ARNU093SJR4

Table 28: ARNU093SJR4 Heating Capacity Table.

Model No. / Capacity Index	Outdoor Air Temp.		Indoor Air Temperature (°F DB)							
			59	61	64	67	70	73	76	80
	°F DB	°F WB	TC MBh	TC MBh	TC MBh	TC MBh	TC MBh	TC MBh	TC MBh	TC MBh
ARNU093SJR4/ 9.6	-21.6	-22.0	5.5	5.5	5.5	5.5	5.5	5.5	5.5	5.5
	-17.1	-17.5	6.2	6.2	6.2	6.2	6.1	6.1	6.1	6.1
	-12.6	-13	6.9	6.9	6.9	6.9	6.8	6.8	6.8	6.8
	-7	-7.6	7.1	7.1	7.1	7.1	7.0	7.0	7.0	7.0
	-4	-4.4	7.3	7.3	7.3	7.3	7.2	7.2	7.2	7.2
	0	-0.4	7.5	7.5	7.5	7.5	7.5	7.4	7.4	7.4
	5	4.5	8.5	8.4	8.3	8.3	8.3	8.3	8.3	8.3
	10	9	8.8	8.8	8.8	8.7	8.7	8.7	8.7	8.7
	15	14	9.4	9.4	9.4	9.4	9.4	9.4	9.3	9.2
	20	19	9.9	9.9	9.9	9.9	9.7	9.7	9.5	9.4
	25	23	10.4	10.4	10.4	10.4	10.4	10.1	10.0	9.5
	30	28	10.6	10.6	10.6	10.6	10.6	10.4	10.0	9.5
	35	32	10.9	10.9	10.9	10.9	10.8	10.6	10.0	9.5
	40	36	11.3	11.3	11.3	11.3	10.9	10.6	10.0	9.5
	45	41	11.8	11.8	11.8	11.5	10.9	10.6	10.0	9.5
	47	43	12.2	12.1	12.0	11.5	10.9	10.6	10.0	9.5
50	46	13.1	12.5	12.0	11.5	10.9	10.6	10.0	9.5	
55	51	13.4	12.6	12.0	11.5	10.9	10.6	10.0	9.5	
60	56	13.4	12.6	12.0	11.5	10.9	10.6	10.0	9.5	

TC: Total Capacity (MBh).

The System Combination Ratio must be between 50–130%.

Rated capacity is certified under AHRI Standard 1230. Ratings are subject to change without notice.

Current certified ratings are available at www.ahrirectory.org.

For outdoor unit performance data, see the respective outdoor unit performance data manuals on <https://lghvac.com/commercial>.

Note:

Low ambient performance with LGRED° heat technology is included in Multi V 5 Air Source Units produced after February 2019.

Table 29: ARNU123SJR4 Heating Capacity Table.

Model No. / Capacity Index	Outdoor Air Temp.		Indoor Air Temperature (°F DB)							
			59	61	64	67	70	73	76	80
	°F DB	°F WB	TC MBh	TC MBh	TC MBh	TC MBh	TC MBh	TC MBh	TC MBh	TC MBh
ARNU123SJR4/ 12.3	-21.6	-22.0	6.9	6.9	6.9	6.9	6.8	6.8	6.8	6.8
	-17.1	-17.5	7.7	7.7	7.7	7.7	7.6	7.6	7.6	7.6
	-12.6	-13	8.6	8.6	8.6	8.6	8.5	8.5	8.5	8.5
	-7	-7.6	8.8	8.8	8.8	8.8	8.7	8.7	8.7	8.7
	-4	-4.4	9.1	9.1	9.1	9.1	9.0	9.0	9.0	9.0
	0	-0.4	9.4	9.4	9.4	9.4	9.4	9.3	9.3	9.3
	5	4.5	10.6	10.5	10.3	10.3	10.3	10.3	10.3	10.3
	10	9	11.0	11.0	11.0	10.9	10.9	10.9	10.9	10.9
	15	14	11.7	11.7	11.7	11.7	11.7	11.7	11.6	11.4
	20	19	12.4	12.4	12.4	12.4	12.1	12.1	11.9	11.8
	25	23	12.9	12.9	12.9	12.9	12.9	12.7	12.5	11.9
	30	28	13.2	13.2	13.2	13.2	13.2	12.9	12.5	11.9
	35	32	13.6	13.6	13.6	13.6	13.5	13.2	12.5	11.9
	40	36	14.1	14.1	14.1	14.1	13.6	13.2	12.5	11.9
	45	41	14.7	14.7	14.7	14.3	13.6	13.2	12.5	11.9
	47	43	15.2	15.1	15.0	14.3	13.6	13.2	12.5	11.9
50	46	16.3	15.6	15.0	14.3	13.6	13.2	12.5	11.9	
55	51	16.7	15.8	15.0	14.3	13.6	13.2	12.5	11.9	
60	56	16.7	15.8	15.0	14.3	13.6	13.2	12.5	11.9	

TC: Total Capacity (MBh).

The System Combination Ratio must be between 50–130%.

Rated capacity is certified under AHRI Standard 1230. Ratings are subject to change without notice.

Current certified ratings are available at www.ahrirectory.org.

For outdoor unit performance data, see the respective outdoor unit performance data manuals on <https://lghvac.com/commercial>.

Note:

Low ambient performance with LGRED® heat technology is included in Multi V 5 Air Source Units produced after February 2019.

ART COOL MIRROR



Heating Capacity Tables

ARNU153SJR4

Table 30: ARNU153SJR4 Heating Capacity Table.

Model No. / Capacity Index	Outdoor Air Temp.		Indoor Air Temperature (°F DB)							
			59	61	64	67	70	73	76	80
	°F DB	°F WB	TC MBh	TC MBh	TC MBh	TC MBh	TC MBh	TC MBh	TC MBh	TC MBh
ARNU153SJR4/ 15.4	-21.6	-22.0	8.7	8.7	8.7	8.7	8.6	8.6	8.6	8.6
	-17.1	-17.5	9.7	9.7	9.7	9.7	9.6	9.6	9.6	9.6
	-12.6	-13	10.8	10.8	10.8	10.8	10.6	10.6	10.6	10.6
	-7	-7.6	11.1	11.1	11.1	11.1	10.9	10.9	10.9	10.9
	-4	-4.4	11.5	11.5	11.5	11.5	11.3	11.3	11.3	11.3
	0	-0.4	11.8	11.8	11.8	11.8	11.8	11.6	11.6	11.6
	5	4.5	13.3	13.2	13.0	13.0	13.0	13.0	13.0	13.0
	10	9	13.9	13.9	13.9	13.7	13.7	13.7	13.7	13.7
	15	14	14.7	14.7	14.7	14.7	14.7	14.7	14.5	14.4
	20	19	15.6	15.6	15.6	15.6	15.2	15.2	15.0	14.8
	25	23	16.3	16.3	16.3	16.3	16.3	15.9	15.7	15.0
	30	28	16.6	16.6	16.6	16.6	16.6	16.3	15.7	15.0
	35	32	17.1	17.1	17.1	17.1	16.9	16.6	15.7	15.0
	40	36	17.8	17.8	17.8	17.8	17.1	16.6	15.7	15.0
	45	41	18.5	18.5	18.5	18.0	17.1	16.6	15.7	15.0
	47	43	19.2	19.0	18.8	18.0	17.1	16.6	15.7	15.0
50	46	20.5	19.7	18.8	18.0	17.1	16.6	15.7	15.0	
55	51	21.0	19.8	18.8	18.0	17.1	16.6	15.7	15.0	
60	56	21.0	19.8	18.8	18.0	17.1	16.6	15.7	15.0	

TC: Total Capacity (MBh).

The System Combination Ratio must be between 50–130%.

Rated capacity is certified under AHRI Standard 1230. Ratings are subject to change without notice.

Current certified ratings are available at www.ahrirectory.org.

For outdoor unit performance data, see the respective outdoor unit performance data manuals on <https://lghvac.com/commercial>.

Note:

Low ambient performance with LGRED° heat technology is included in Multi V 5 Air Source Units produced after February 2019.

Table 31: ARNU183SKR4 Heating Capacity Table.

Model No. / Capacity Index	Outdoor Air Temp.		Indoor Air Temperature (°F DB)							
			59	61	64	67	70	73	76	80
	°F DB	°F WB	TC	TC	TC	TC	TC	TC	TC	TC
MBh			MBh	MBh	MBh	MBh	MBh	MBh	MBh	MBh
ARNU183SKR4/ 19.1	-21.6	-22.0	10.9	10.9	10.9	10.9	10.8	10.8	10.8	10.8
	-17.1	-17.5	12.2	12.2	12.2	12.2	12.1	12.1	12.1	12.1
	-12.6	-13	13.6	13.6	13.6	13.6	13.4	13.4	13.4	13.4
	-7	-7.6	14.0	14.0	14.0	14.0	13.8	13.8	13.8	13.8
	-4	-4.4	14.4	14.4	14.4	14.4	14.2	14.2	14.2	14.2
	0	-0.4	14.8	14.8	14.8	14.8	14.8	14.6	14.6	14.6
	5	4.5	16.8	16.6	16.3	16.3	16.3	16.3	16.3	16.3
	10	9	17.4	17.4	17.4	17.2	17.2	17.2	17.2	17.2
	15	14	18.5	18.5	18.5	18.5	18.5	18.5	18.3	18.1
	20	19	19.6	19.6	19.6	19.6	19.1	19.1	18.8	18.6
	25	23	20.4	20.4	20.4	20.4	20.4	20.0	19.8	18.8
	30	28	20.9	20.9	20.9	20.9	20.9	20.4	19.8	18.8
	35	32	21.5	21.5	21.5	21.5	21.3	20.9	19.8	18.8
	40	36	22.4	22.4	22.4	22.4	21.5	20.9	19.8	18.8
	45	41	23.2	23.2	23.2	22.6	21.5	20.9	19.8	18.8
	47	43	24.1	23.9	23.7	22.6	21.5	20.9	19.8	18.8
50	46	25.8	24.7	23.7	22.6	21.5	20.9	19.8	18.8	
55	51	26.3	24.9	23.7	22.6	21.5	20.9	19.8	18.8	
60	56	26.3	24.9	23.7	22.6	21.5	20.9	19.8	18.8	

TC: Total Capacity (MBh).

The System Combination Ratio must be between 50–130%.

Rated capacity is certified under AHRI Standard 1230. Ratings are subject to change without notice.

Current certified ratings are available at www.ahrirectory.org.

For outdoor unit performance data, see the respective outdoor unit performance data manuals on <https://lghvac.com/commercial>.

Note:

Low ambient performance with LGRED° heat technology is included in Multi V 5 Air Source Units produced after February 2019.

ART COOL MIRROR



Heating Capacity Tables

ARNU243SKR4

Table 32: ARNU243SKR4 Heating Capacity Table.

Model No. / Capacity Index	Outdoor Air Temp.		Indoor Air Temperature (°F DB)							
			59	61	64	67	70	73	76	80
	°F DB	°F WB	TC	TC	TC	TC	TC	TC	TC	TC
		MBh	MBh	MBh	MBh	MBh	MBh	MBh	MBh	MBh
ARNU243SKR4/ 24.2	-21.6	-22.0	13.0	13.0	13.0	13.0	12.8	12.8	12.8	12.8
	-17.1	-17.5	14.6	14.6	14.6	14.6	14.4	14.4	14.4	14.4
	-12.6	-13	16.1	16.1	16.1	16.1	15.9	15.9	15.9	15.9
	-7	-7.6	16.6	16.6	16.6	16.6	16.4	16.4	16.4	16.4
	-4	-4.4	17.2	17.2	17.2	17.2	16.9	16.9	16.9	16.9
	0	-0.4	17.7	17.7	17.7	17.7	17.7	17.4	17.4	17.4
	5	4.5	20.0	19.7	19.5	19.5	19.5	19.5	19.5	19.5
	10	9	20.7	20.7	20.7	20.5	20.5	20.5	20.5	20.5
	15	14	22.0	22.0	22.0	22.0	22.0	22.0	21.8	21.5
	20	19	23.3	23.3	23.3	23.3	22.8	22.8	22.4	22.1
	25	23	24.3	24.3	24.3	24.3	24.3	23.8	23.6	22.4
	30	28	24.8	24.8	24.8	24.8	24.8	24.3	23.6	22.4
	35	32	25.6	25.6	25.6	25.6	25.3	24.8	23.6	22.4
	40	36	26.6	26.6	26.6	26.6	25.6	24.8	23.6	22.4
	45	41	27.7	27.7	27.7	26.9	25.6	24.8	23.6	22.4
	47	43	28.7	28.4	28.2	26.9	25.6	24.8	23.6	22.4
	50	46	30.7	29.4	28.2	26.9	25.6	24.8	23.6	22.4
55	51	31.4	29.7	28.2	26.9	25.6	24.8	23.6	22.4	
60	56	31.4	29.7	28.2	26.9	25.6	24.8	23.6	22.4	

TC: Total Capacity (MBh).

The System Combination Ratio must be between 50–130%.

Rated capacity is certified under AHRI Standard 1230. Ratings are subject to change without notice.

Current certified ratings are available at www.ahrirectory.org.

For outdoor unit performance data, see the respective outdoor unit performance data manuals on <https://lghvac.com/commercial>.

Note:

Low ambient performance with LGRED° heat technology is included in Multi V 5 Air Source Units produced after February 2019.

STANDARD WALL-MOUNTED

Mechanical Specifications on page 66

General Data on page 68

Electrical Data on page 70

External Dimensions on page 71

Electrical Wiring Diagrams on page 74

Refrigerant Flow Diagram on page 76

Acoustic Data on page 77

Air Velocity / Temperature Distribution on page 81

Capacity Tables on page 96

STANDARD WALL-MOUNTED



Mechanical Specifications

Casing

Units are designed to mount on a vertical surface and come complete with an installation mounting guide and a separate hanging bracket. The unit case is manufactured with coated metal. Cold surfaces are covered with a coated polystyrene insulating material.

Finish

The unit case is manufactured using ABS polymeric resin and has a pearl white finish.

Fan Assembly and Control

The unit has a single, direct-drive, crossflow tangential Sirocco fan made of high strength ABS BSN-7530 polymeric resin. The fan motor is a Brushless Digitally Controlled (BLDC) design with permanently lubricated and sealed ball bearings. The fan motor includes thermal, overcurrent and low RPM protection. The fan/motor assembly is mounted on vibration attenuating rubber grommets. The fan impeller is statically and dynamically balanced. The fan speed is controlled using a microprocessor-based direct digital control algorithm that provides a high fan speed in cooling thermal ON and low fan speed in cooling thermal OFF, high fan speed in heating thermal ON and fan off in heating thermal OFF. The fan speeds can be field adjusted between low, medium, and high speeds. The fan speed algorithm provides a field-selectable fixed-speed or auto-speed setting that changes the fan speed to simulate natural airflow.

Air Filter

Return air is filtered with a removable, washable filter with anti-fungal treatment. Filter access is from the front of the unit without the use of tools.

Airflow Guide Vanes

5–15 MBh

The indoor unit is provided with a motorized oscillating guide vane that automatically changes the direction of up-and-down airflow. The indoor unit includes factory installed, manually adjustable guide vanes that control the side-to-side direction of supplied airflow.

18-36 MBh

The indoor unit is provided with a motorized sweeping guide vane that automatically changes the direction of airflow from side-to-side and up-and-down.

Microprocessor Control

The unit is provided with an integrated microprocessor controller capable of performing functions necessary to operate the system without the use of a wall-mounted controller. A temperature thermistor is factory mounted in the return air stream. All unit operation



parameters, excluding the operating schedule, are stored in non-volatile memory resident on the unit microprocessor. Operating schedules are stored in select models of the optional, wall-mounted, local or central controllers. The field-supplied communication cable between the indoor unit(s) and outdoor unit is to be a minimum of 18 AWG, 2 conductor, stranded, and shielded cable (RS-485), terminated via screw terminals on the control boards. The microprocessor control provides the following functions: auto addressing, self-diagnostics, auto restart following power restoration, test run, and will operate the indoor unit using one of five operation modes:

1. Auto Changeover (Heat Recovery only)
2. Heating
3. Cooling
4. Dry
5. Fan Only

For Heat Recovery systems the Auto Changeover setting automatically switches control of the indoor unit between Cooling and Heating modes based on space temperature conditions.

For Heat Pump systems, heated or cooled air delivery is dependent upon outdoor unit operating mode.

In Heating mode, the microprocessor control will activate indoor unit operation when the indoor room temperature falls below set-point temperature. At which point, a signal is sent to the outdoor unit to begin the heating cycle. The indoor unit fan operation is delayed until coil pipe temperature reaches 76°F. Significant airflow is generated when pipe temperature reaches 80°F. A field-selectable option maintains fan operation for 30 minutes following cooling cycle operations. The unit is equipped with an infrared receiver designed to communicate with an LG wireless remote controller. In lieu of wireless remote or factory return air thermistor, screw terminals on the microprocessor circuit board accommodates various models of wall-mounted local controllers. The unit microprocessor is capable of accepting space temperature readings concurrently or individually from either:

1. Wall-mounted wired controller(s)
2. Factory-mounted return air thermistor

A single indoor unit has the capability of being controlled by up to two local wired controllers. The microprocessor controls space

temperature using the value provided by the temperature sensor sensing a space temperature that is farthest away from the temperature set-point. The microprocessor control provides a cooling or heating mode test cycle that operates the unit for 18 minutes without regard to the space temperature. If the system is provided with an optional wall-mounted local or central controller, displayed diagnostic codes are specific, alpha-numeric, and provide the service technician with a reason for the code displayed.

Indoor units have built-in Wi-Fi and can be controlled by LG ThinQ app on a smart device. A field-supplied Wi-Fi network and smart device are required. LG ThinQ app is free, and is available for Android™ and iOS. (Android is a trademark of Google LLC.)

Handling Condensate

The unit is designed for gravity draining of condensate. LG provides a factory insulated flexible drain hose. If condensate lift/pumps are needed for the application, they are to be field provided.

Condensate Drain Pan

The condensate drain pan is constructed of expandable polystyrene resin (EPS).

Coil

The indoor unit coil is constructed with grooved design copper tubes with slit coil fins, two (2) rows, eighteen (18) fins per inch.

Controls Features

- Auto changeover (Heat Recovery only)
- Auto operation
- Auto clean (coil dry; requires wireless controller)
- External on/off control
- Dual thermistor control
- Dual set-point control
- Filter life display
- Group control
- Forced operation
- Hot start
- Self diagnostics
- Timer (on/off)
- Weekly schedule
- Auto direction/swing (up/down)
- Fan speed control
- Jet cool (fast cooling)
- Wi-Fi
- Auto Fan
- Leak detection

**To enable Generation 4 features, outdoor unit DIP Switch No. 3 must be set to ON. Please refer to the Multi V 5, Multi V IV, Multi V Water IV, Multi V S Engineering Manual for additional information.*

STANDARD WALL-MOUNTED



General Data

Table 33: Standard Wall-Mounted (SJ Frames) Indoor Unit General Data.

Model No.	ARNU053SJS4	ARNU073SJS4	ARNU093SJS4	ARNU123SJS4	ARNU153SJS4
Cooling Mode Performance					
Capacity (Btu/h)	5,500	7,500	9,600	12,300	15,400
Max. Power Input ¹ (W)	30	30	30	30	30
H / M / L Power Input at Factory Default (W)	11 / 10 / 9	12 / 11 / 9	13 / 12 / 9	15 / 13 / 11	23 / 18 / 11
Heating Mode Performance					
Capacity (Btu/h)	6,100	8,500	10,900	13,600	17,100
Max. Power Input ¹ (W)	30	30	30	30	30
H / M / L Power Input at Factory Default (W)	11 / 10 / 9	12 / 11 / 9	13 / 12 / 9	15 / 13 / 11	23 / 18 / 11
Entering Mixed Air					
Cooling Max (°F WB) ²	76	76	76	76	76
Heating Min (°F DB) ²	59	59	59	59	59
Unit Data					
Refrigerant Type ³	R410A	R410A	R410A	R410A	R410A
Refrigerant Control	EEV	EEV	EEV	EEV	EEV
Sound Pressure ⁴ dB(A) (H/M/L)	30 / 29 / 28	32 / 30 / 28	34 / 32 / 28	37 / 34 / 30	42 / 39 / 32
Net Unit Weight (lbs.)	19.6	19.6	19.6	19.6	19.6
Shipping Weight (lbs.)	21.8	21.8	21.8	21.8	21.8
Communication Cable ⁵ (No. x AWG)	2 x 18	2 x 18	2 x 18	2 x 18	2 x 18
Fan					
Type	Cross Flow	Cross Flow	Cross Flow	Cross Flow	Cross Flow
Quantity	1	1	1	1	1
Motor/Drive	Brushless Digitally Controlled / Direct				
Airflow Rate H / M / L (CFM)	240 / 230 / 208	254 / 240 / 208	275 / 254 / 208	300 / 254 / 240	371 / 336 / 240
Piping					
Liquid Line (in., O.D.)	1/4 Flare	1/4 Flare	1/4 Flare	1/4 Flare	1/4 Flare
Vapor Line (in., O.D.)	1/2 Flare	1/2 Flare	1/2 Flare	1/2 Flare	1/2 Flare
Condensate Line (in., I.D.)	5/8	5/8	5/8	5/8	5/8

EEV: Electronic Expansion Valve

Power wiring is field supplied and must comply with the applicable local and national codes.

This unit comes with a dry nitrogen charge.

All capacities are net with a combination ratio between 95-105%.

Rated capacity is certified under AHRI Standard 1230. Ratings are subject to change without notice. Current certified ratings are available at www.ahridirectory.org.

¹Max. power input is rated at maximum setting value.

²Low ambient performance with LGRED[®] heat technology is included in Multi V 5 Air

Source Units produced after February 2019.

³Take appropriate actions at the end of HVAC equipment life to recover, recycle, reclaim or destroy R410A refrigerant according to applicable regulations (40 CFR Part 82, Subpart F) under section 608 of CAA.

⁴Sound Pressure levels are tested in an anechoic chamber under ISO Standard 3745.

⁵All communication cable to be minimum 18 AWG, 2-conductor, twisted, stranded, shielded and must comply with applicable local and national codes. Ensure the communication cable is properly grounded at the main outdoor unit only. Ⓢ Do not ground the ODU-IDU communication cable at any other point.



Table 34: Standard Wall-Mounted (SK and SV Frames) Indoor Unit General Data.

Model No.	ARNU183SKS4	ARNU243SKS4	ARNU303SVA4	ARNU363SVA4
Cooling Mode Performance				
Capacity (Btu/h)	19,100	24,200	30,000	35,500
Max. Power Input ¹ (W)	53	53	67.0	104.0
H / M / L Power Input at Factory Default (W)	32 / 26 / 16	39 / 26 / 16	54 / 43 / 31	85 / 51 / 36
Heating Mode Performance				
Capacity (Btu/h)	21,500	25,600	32,000	37,000
Max. Power Input ¹ (W)	53	53	67.0	104.0
H / M / L Power Input at Factory Default (W)	32 / 26 / 16	39 / 26 / 16	54 / 43 / 31	85 / 51 / 36
Entering Mixed Air				
Cooling Max (°F WB) ²	76	76	76	76
Heating Min (°F DB) ²	59	59	59	59
Unit Data				
Refrigerant Type ³	R410A	R410A	R410A	R410A
Refrigerant Control	EEV	EEV	EEV	EEV
Sound Pressure ⁴ dB(A) (H / M / L)	43 / 39 / 34	46 / 41 / 34	49 / 44 / 42	52 / 47 / 43
Net Unit Weight (lbs.)	28.7	28.7	37	37
Shipping Weight (lbs.)	31.7	31.7	48	48
Communication Cable ⁵ (No. x AWG)	2 x 18	2 x 18	2 x 18	2 x 18
Fan				
Type	Cross Flow	Cross Flow	Cross Flow	Cross Flow
Quantity	1	1	1	1
Motor/Drive	Brushless Digitally Controlled / Direct			
Airflow Rate H/M/L (CFM)	494 / 424 / 371	537 / 449 / 371	812 / 706 / 600	918 / 812 / 671
Piping				
Liquid Line (in., O.D.)	1/4 Flare	3/8 Flare	3/8 Flare	3/8 Flare
Vapor Line (in., O.D.)	1/2 Flare	5/8 Flare	5/8 Flare	5/8 Flare
Condensate Line (in., I.D.)	5/8	5/8	5/8	5/8

EEV: Electronic Expansion Valve
Power wiring is field supplied and must comply with the applicable local and national codes.

This unit comes with a dry nitrogen charge.
All capacities are net with a combination ratio between 95-105%.
Rated capacity is certified under AHRI Standard 1230. Ratings are subject to change without notice. Current certified ratings are available at www.ahridirectory.org.

¹Max. power input is rated at maximum setting value.
²Low ambient performance with LGRED[®] heat technology is included in Multi V 5 Air Source Units produced after February 2019.

³Take appropriate actions at the end of HVAC equipment life to recover, recycle, reclaim or destroy R410A refrigerant according to applicable regulations (40 CFR Part 82, Subpart F) under section 608 of CAA.

⁴Sound Pressure levels are tested in an anechoic chamber under ISO Standard 3745.
⁵All communication cable to be minimum 18 AWG, 2-conductor, twisted, stranded, shielded and must comply with applicable local and national codes. Ensure the communication cable is properly grounded at the main outdoor unit only. Ⓞ Do not ground the ODU-IDU communication cable at any other point.

STANDARD WALL-MOUNTED



Electrical Data

Table 35: Standard Wall-Mounted Indoor Unit Electrical Data.

Model Number	Voltage Range	MCA	MOP	Rated Amps (A)	Power Supply			Power Input (W)		
					Hz	Volts	Phase	Max. Cooling	Max. Heating	H / M / L at Factory Default
SJ Frames										
ARNU053SJS4	187-253	0.31	15	0.25	60	208-230	1	30	30	11 / 10 / 9
ARNU073SJS4		0.31		0.25				30	30	12 / 11 / 9
ARNU093SJS4		0.31		0.25				30	30	13 / 12 / 9
ARNU123SJS4		0.31		0.25				30	30	15 / 13 / 11
ARNU153SJS4		0.31		0.25				30	30	23 / 18 / 11
SK Frames										
ARNU183SKS4	187-253	0.65	15	0.52	60	208-230	1	53	53	32 / 26 / 16
ARNU243SKS4		0.65		0.52				53	53	39 / 26 / 16
SV Frames										
ARNU303SVA4	187-253	0.64	15	0.51	60	208-230	1	67.0	67.0	54 / 43 / 31
ARNU363SVA4		1.02		0.81				104.0	104.0	85 / 51 / 36

MCA : Minimum Circuit Ampacity.

MOP : Maximum Overcurrent Protection.

Units are suitable for use on an electrical system where voltage supplied to unit terminals is within the listed range limits.

Select wire size based on the larger MCA value.

Instead of fuse, use the circuit breaker.

Max. power input is rated at maximum setting value.

Figure 22: ARNU053SJS4, ARNU073SJS4, ARNU093SJS4, ARNU123SJS4, ARNU153SJS4 Dimensions.

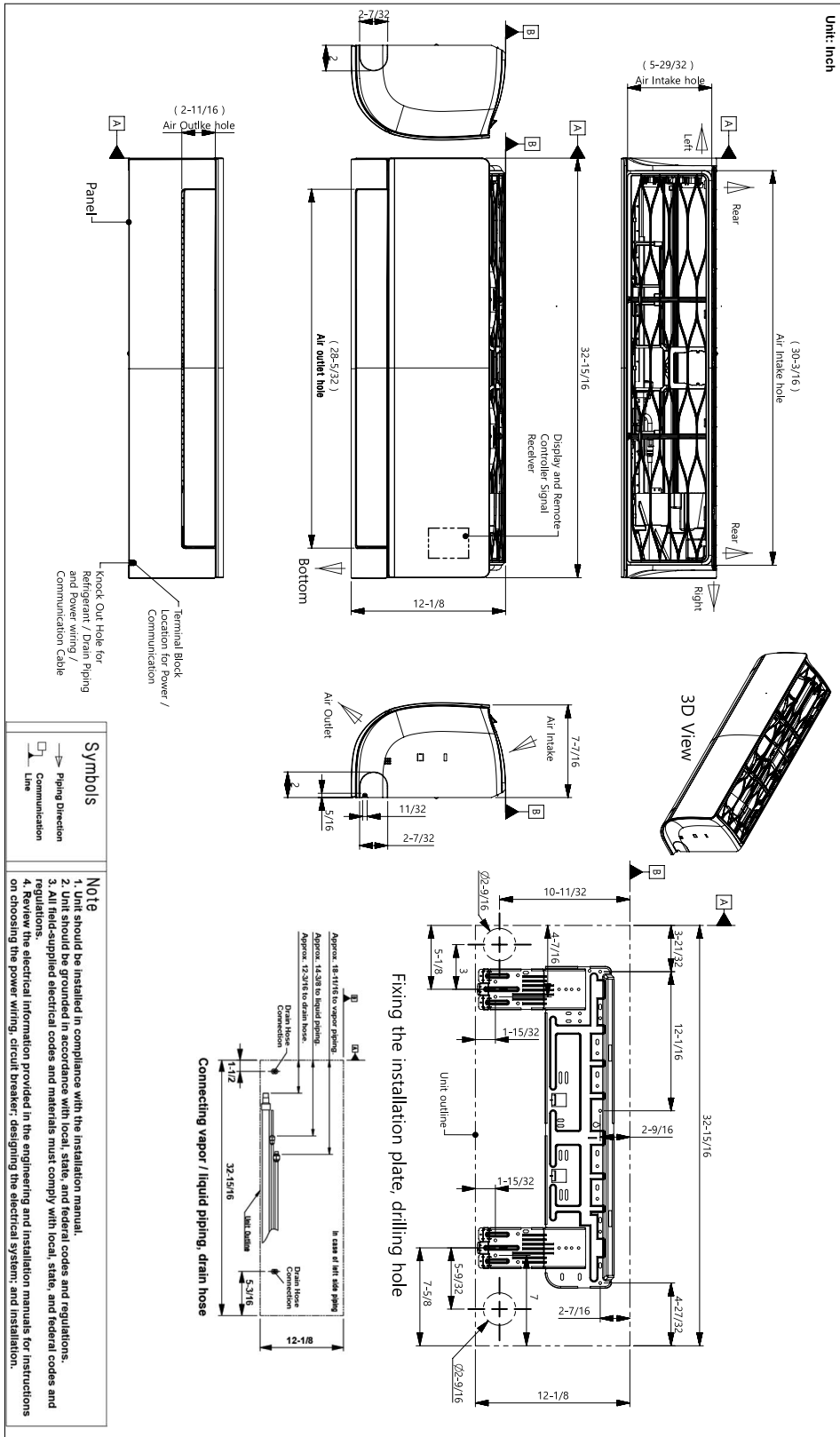

STANDARD WALL-MOUNTED



External Dimensions

SK Frame

Figure 23: ARNU183SKS4, ARNU243SKS4 Dimensions.

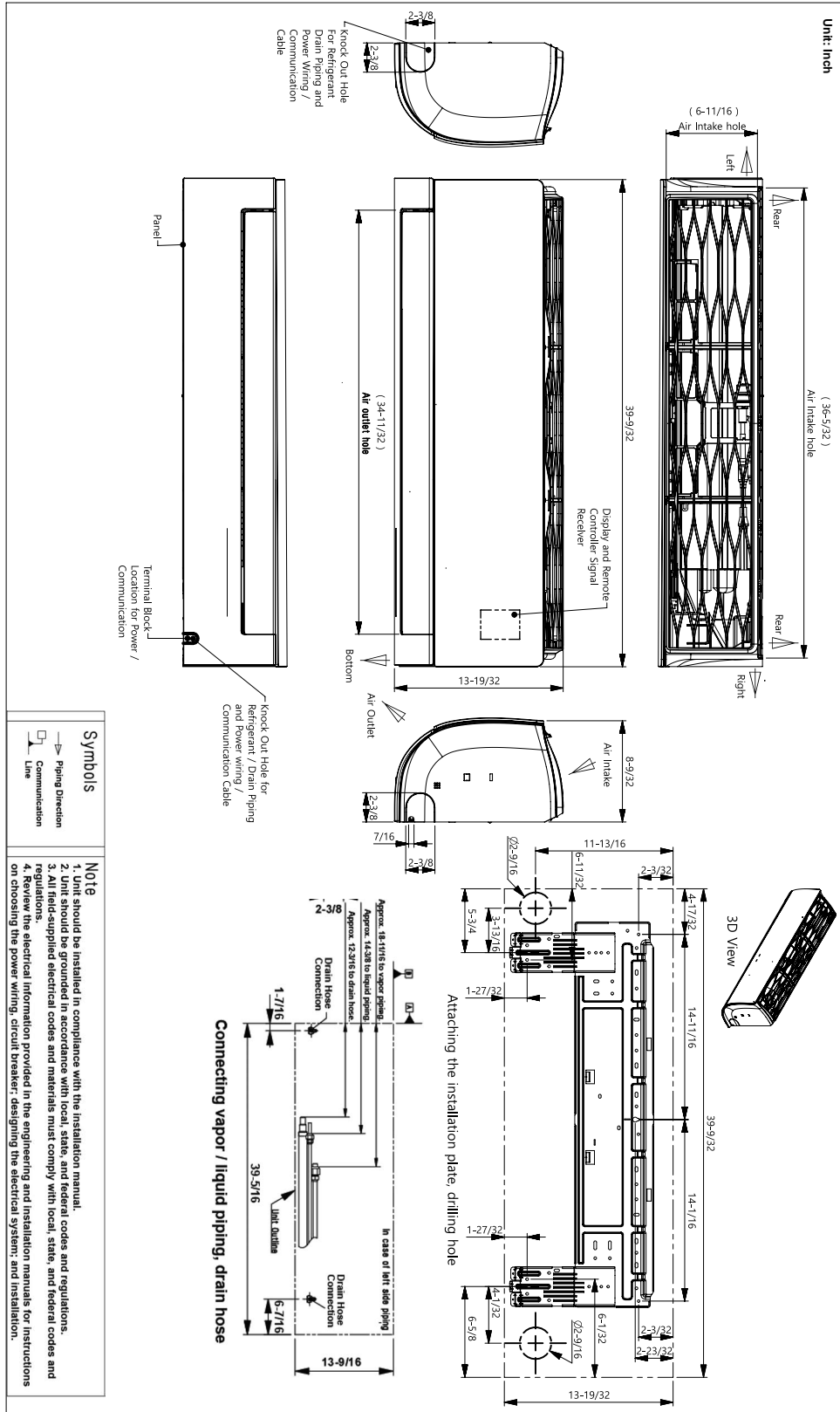
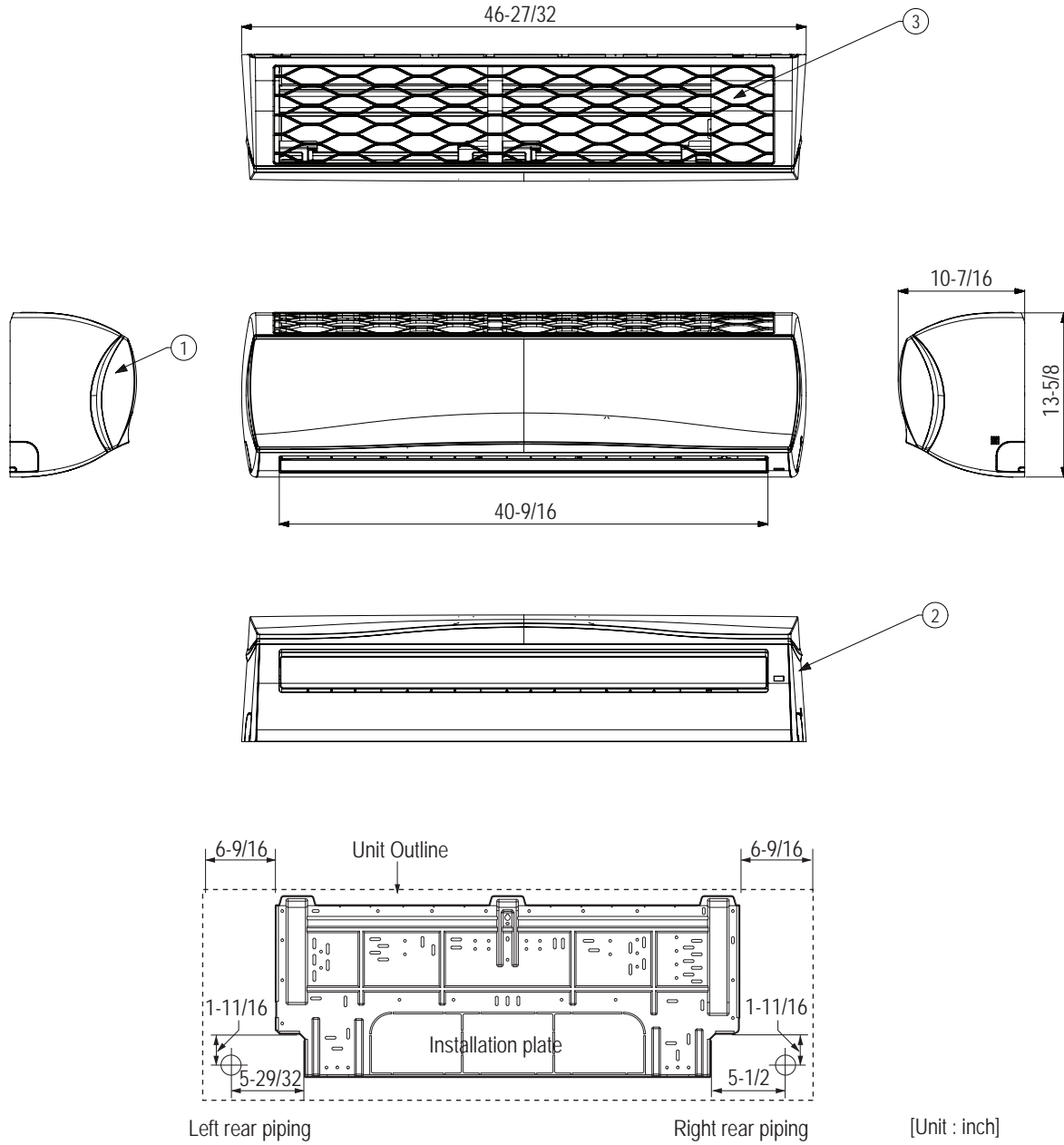

Figure 24: ARNU303SVA4, ARNU363SVA4 Dimensions.



[Unit : inch]

Note:

1. Unit must be installed in compliance with the installation manual.
2. Unit must be grounded in accordance with the local regulations or applicable national codes.

Item No.	Part Name	Remark
1	Front Panel	
2	Display & Signal Receiver	
3	Air Suction Grille	
4	Installation Plate	

STANDARD WALL-MOUNTED



Electrical Wiring Diagram SJ and SK Frames

Figure 25: ARNU053-153SJS4 and ARNU183-243SKS4 Wiring Diagram.

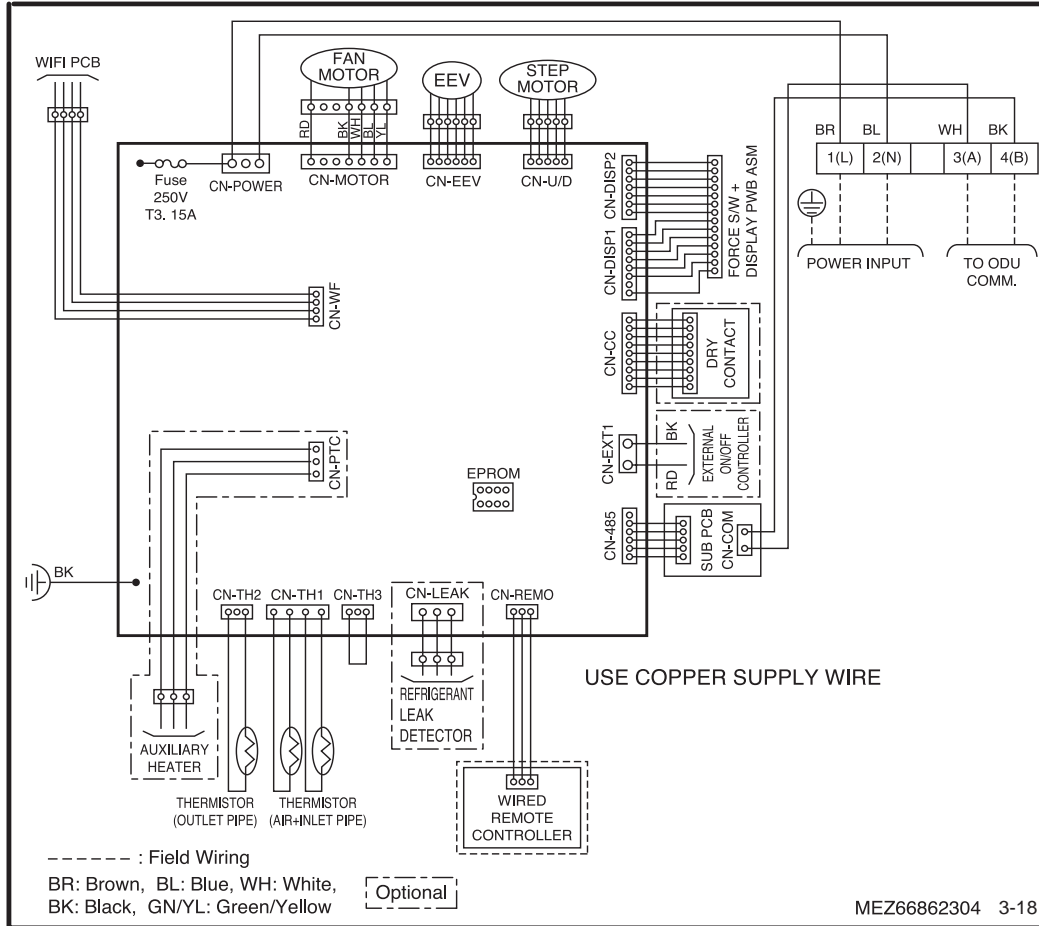

Table 36: SJ and SK Frame Wiring Diagram Legend.

PCB Connection	Purpose	Function
CN-POWER	AC power supply	AC Power line input for indoor controller
CN-MOTOR	Fan motor output	Motor output of BLDC
CN-EEV	EEV output	EEV control output
CN-U/D	Step motor	Step motor output
CN-DISP2	Display	Display of indoor status
CN-DISP1	Display	Display of indoor status
CN-CC	Dry contact	Dry contact connection
CN-EXT1	External ON / OFF controller	External ON / OFF controller connection
CN-485	Communication	Connection between indoor and outdoor units
CN-REMO	Remote controller	Remote control connection
CN-LEAK	Refrigerant leak detector	Refrigerant leak detector connection
CN-TH3	Float switch	Float switch connection
CN-TH1	Return air and inlet pipe thermistor	Return air and inlet pipe thermistor connection
CN-TH2	Outlet pipe thermistor	Outlet pipe thermistor connection
CN-PTC	Auxiliary heater	Auxiliary heater connection
CN-WF	Wi-Fi module	Wi-Fi module connection

*To enable Generation 4 features, outdoor unit DIP switch no. 3 must be set to ON. Please refer to the Multi V 5, Multi V IV, Multi V Water IV, Multi V S Engineering Manual for additional information.



Figure 26: ARNU303SVA4 and ARNU363SVA4 Wiring Diagram.

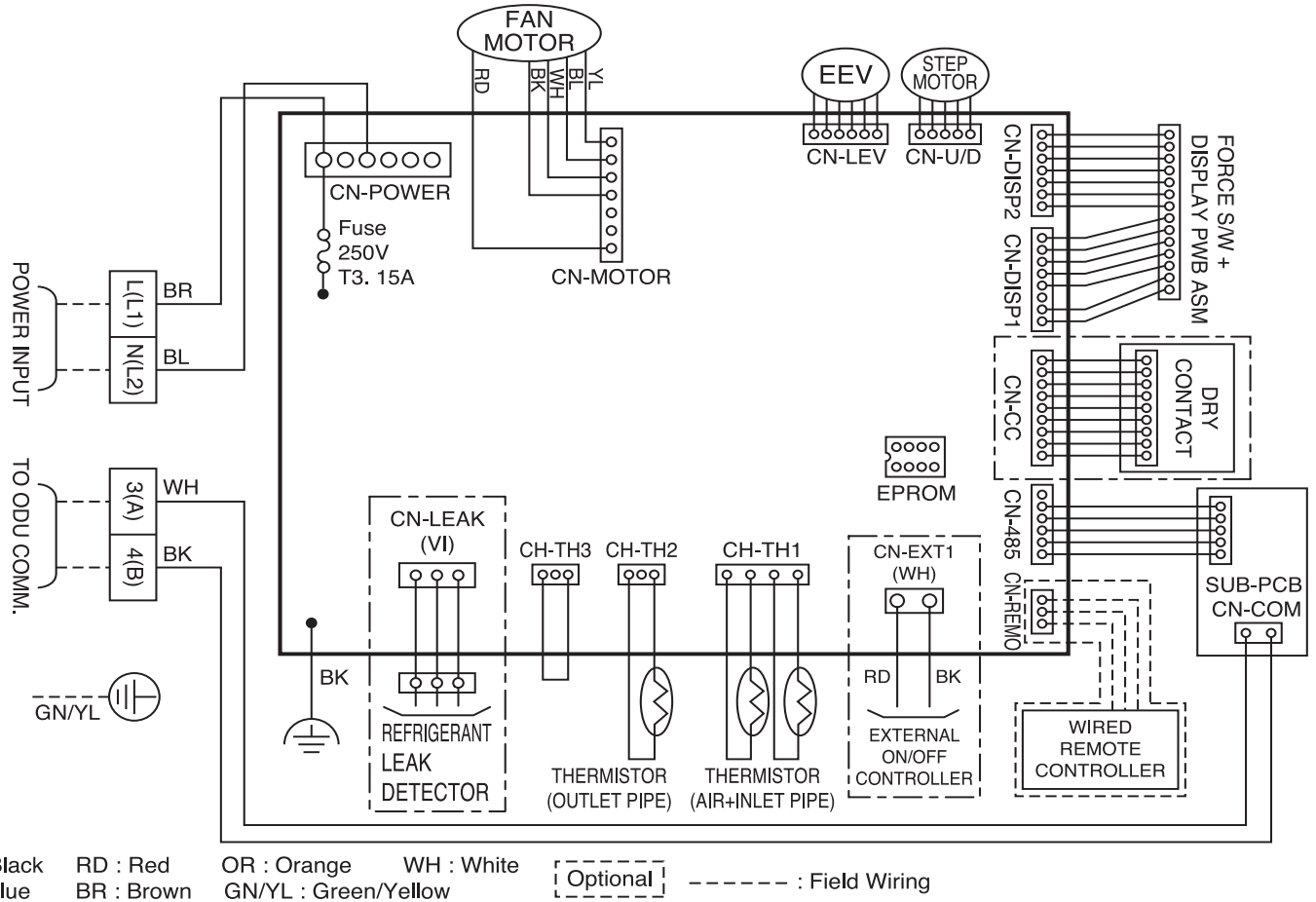

Standard Wall-Mounted

Table 37: SV Frame Wiring Diagram Legend.

PCB Connection	Purpose	Function
CN-POWER	AC Power supply	AC Power line input for indoor controller
CN-MOTOR	Fan motor output	Motor output of BLDC
CN-LEV	EEV output	EEV control output
CN-U/D	Step motor	Step motor output
CN-DISP2	Display	Display of indoor status
CN-DISP1	Display	Display of indoor status
CN-CC	Dry contact	Dry contact connection
CN-485	Communication	Connection between indoor and outdoor units
CN-REMO	Remote controller	Remote control connection
CN-EXT1	External ON / OFF controller	External ON / OFF controller connection
CN-TH1	Return air and inlet pipe thermistor	Return air and inlet pipe thermistor connection
CN-TH2	Outlet pipe thermistor	Outlet pipe thermistor connection
CN-TH3	Float switch	Float switch connection

*To enable Generation 4 features, outdoor unit DIP switch no. 3 must be set to ON. Please refer to the Multi V 5, Multi V IV, Multi V Water IV, Multi V S Engineering Manual for additional information.

STANDARD WALL-MOUNTED

Refrigerant Flow Diagram SJ, SK, SV Frames

Figure 27: SJ, SK, and SV Frame Piping Diagram.

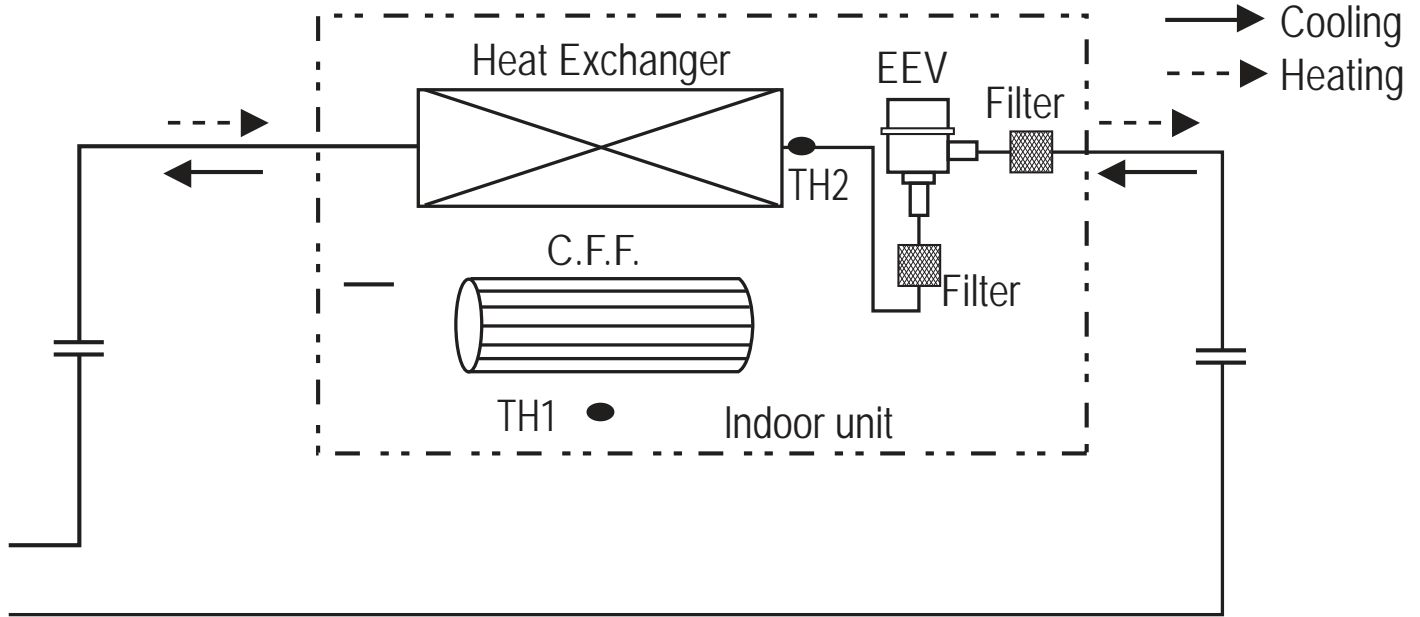

Table 38: SJ, SK, and SV Frame Refrigerant Pipe Connection Port Diameters.

Model	Liquid (inch)	Vapor (inch)
SJ Frames		
ARNU053SJS4	1/4 Flare	1/2 Flare
ARNU073SJS4		
ARNU093SJS4		
ARNU123SJS4		
ARNU153SJS4		
SK Frames		
ARNU183SKS4	1/4 Flare	1/2 Flare
ARNU243SKS4	3/8 Flare	5/8 Flare
SV Frames		
ARNU303SVA4	3/8 Flare	5/8 Flare
ARNU363SVA4		

Table 39: SJ, SK, and SV Frame Thermistors.

Thermistor	Description
TH1	Return air and pipe in thermistor
TH2	Pipe out thermistor

Figure 28: Sound Pressure Measurement Location.

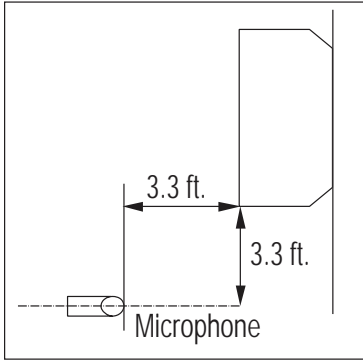

- Measurements are taken 3.3 ft away from the front of the unit.
- Data is valid under nominal operating conditions.
- Sound pressure levels are measured in dB(A) with a tolerance of ± 3 .
- Sound pressure levels are tested in an anechoic chamber under ISO Standard 3745.
- Reference acoustic pressure: 0dB = 20 μ Pa.

Operating Conditions:

- Power source: 220V/60 Hz
- Sound level will vary depending on a range of factors including the construction (acoustic absorption coefficient) of a particular room in which the unit was installed.

Table 40: Standard Wall-Mounted Sound Pressure Levels.

Model	Sound Pressure Levels dB(A)		
	High Fan Speed	Medium Fan Speed	Low Fan Speed
SJ Frames			
ARNU053SJS4	30.0	29.0	28.0
ARNU073SJS4	32.0	30.0	28.0
ARNU093SJS4	34.0	32.0	28.0
ARNU123SJS4	37.0	34.0	30.0
ARNU153SJS4	42.0	39.0	32.0
SK Frames			
ARNU183SKS4	43.0	39.0	34.0
ARNU243SKS4	46.0	41.0	34.0
SV Frames			
ARNU303SVA4	49.0	44.0	42.0
ARNU363SVA4	52.0	47.0	43.0

Figure 29: ARNU053SJS4, ARNU073SJS4, and ARNU093SJS4 Sound Pressure Level Diagrams.

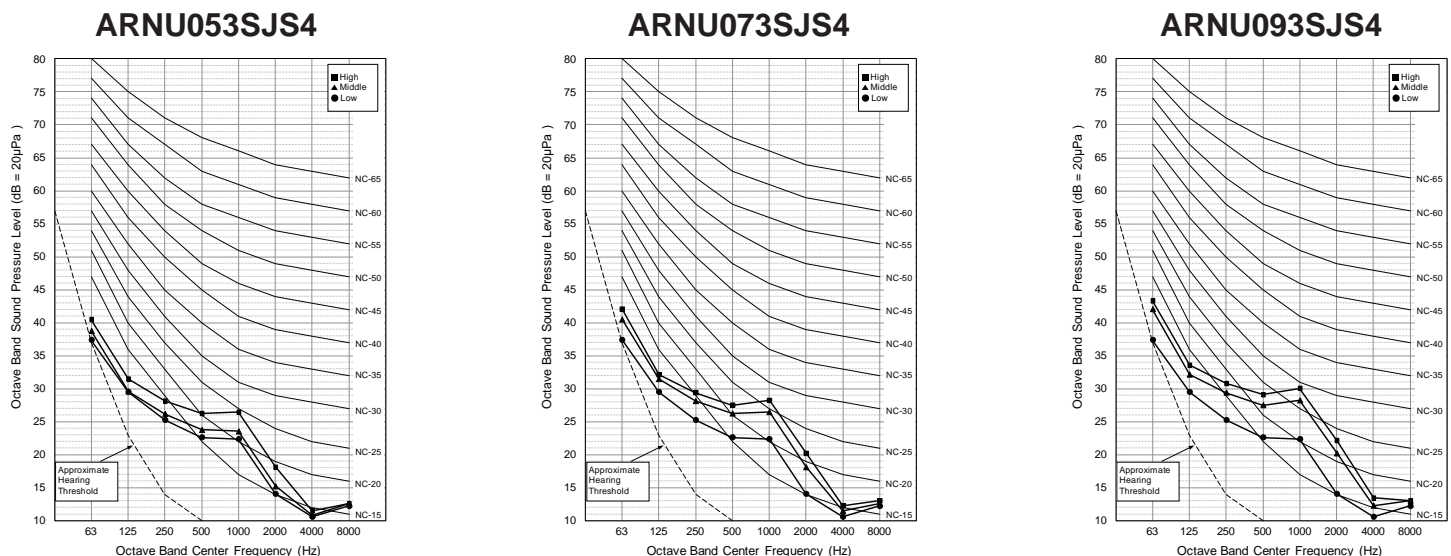

STANDARD WALL-MOUNTED



Acoustic Data

Sound Pressure Levels

Figure 30: ARNU123SJS4, ARNU153SJS4, and ARNU183SKS4 Sound Pressure Level Diagrams.

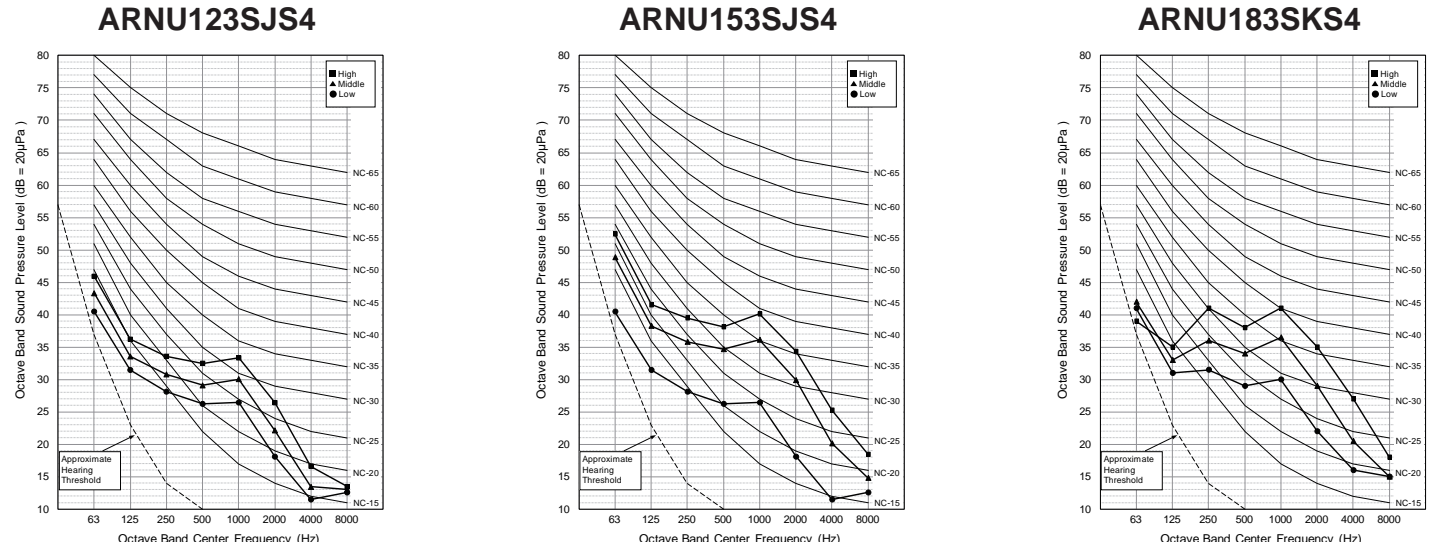

Figure 31: ARNU243SKS4, ARNU303SVA4, and ARNU363SVA4 Sound Pressure Level Diagram.

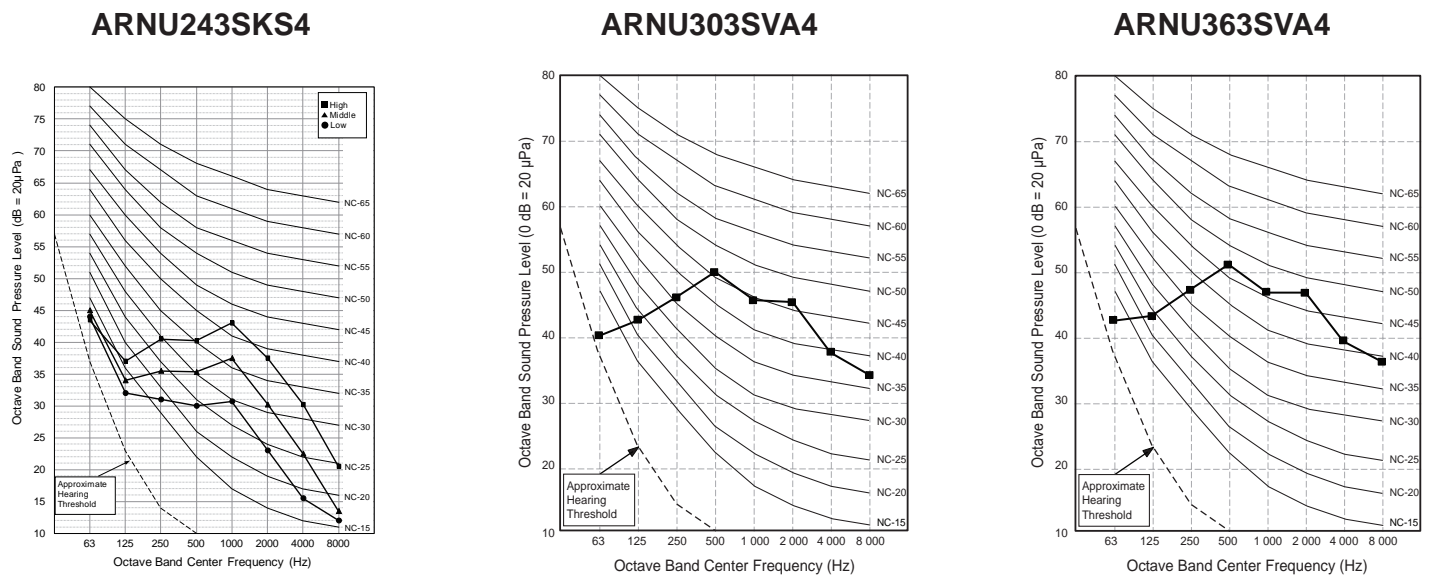

Table 41: Standard Wall-Mounted Indoor Unit Sound Power Levels.

Model	Sound Power Levels dB(A)
	High Fan Speed
SJ Frames	
ARNU053SJS4	54.0
ARNU073SJS4	54.0
ARNU093SJS4	55.0
ARNU123SJS4	55.0
ARNU153SJS4	58.0
SK Frames	
ARNU183SKS4	63.0
ARNU243SKS4	65.0
SV Frames	
ARNU303SVA4	61.0
ARNU363SVA4	63.0

- Data is valid under diffuse field conditions.
- Data is valid under nominal operating conditions.
- Sound power level is measured using rated conditions, and tested in a reverberation room per ISO 3741 standards.
- Sound level will vary depending on a range of factors such as construction (acoustic absorption coefficient) of particular area in which the equipment is installed.
- Reference acoustic intensity: 0dB = 10E-6μW/m²

Figure 32: ARNU053SJS4, ARNU073SJS4, and ARNU093SJS4 Sound Power Level Diagrams.

ARNU053SJS4

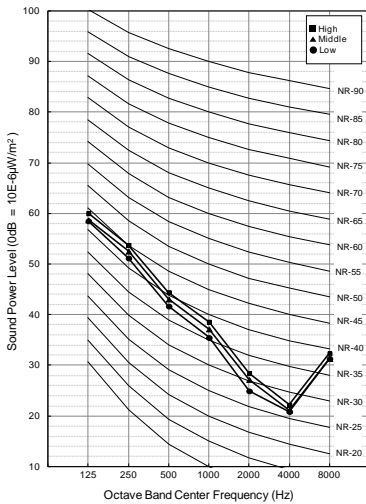

ARNU073SJS4

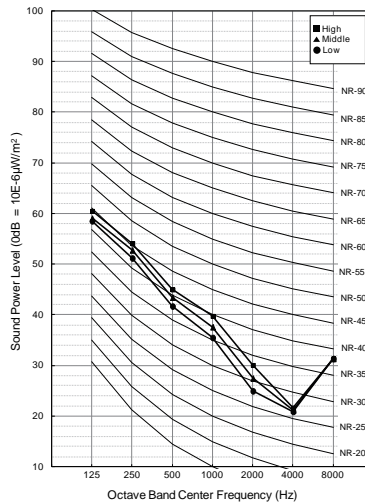

ARNU093SJS4

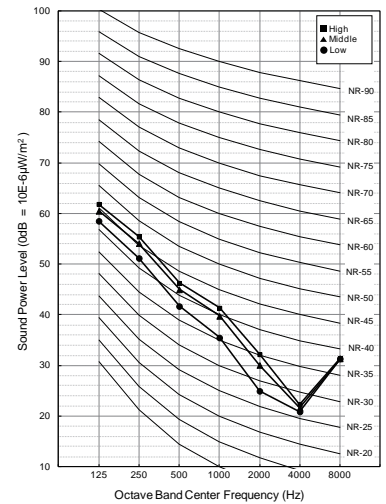

STANDARD WALL-MOUNTED



Acoustic Data

Sound Power Levels

Figure 33: ARNU123SJS4, ARNU153SJS4, and ARNU183SKS4 Sound Power Level Diagrams.

ARNU123SJS4

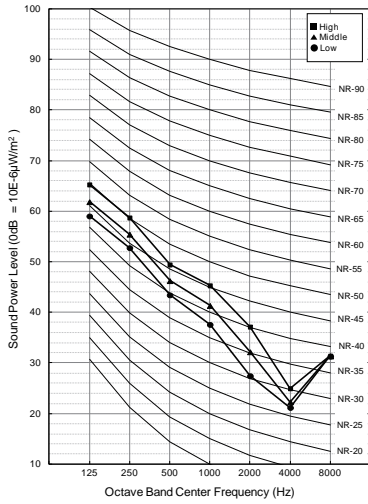

ARNU153SJS4

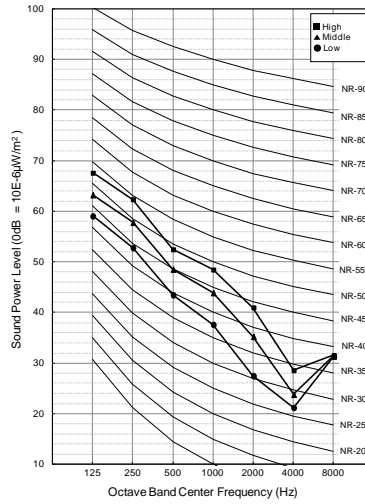

ARNU183SKS4

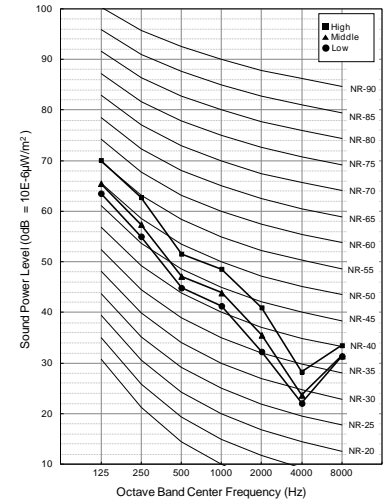
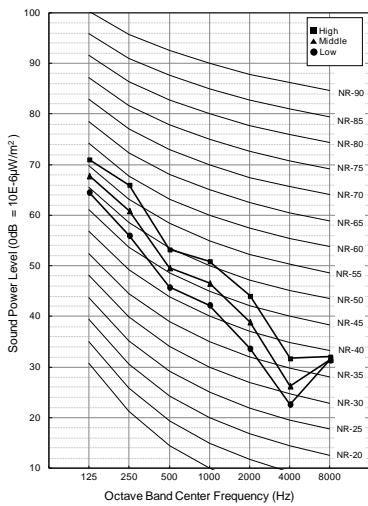
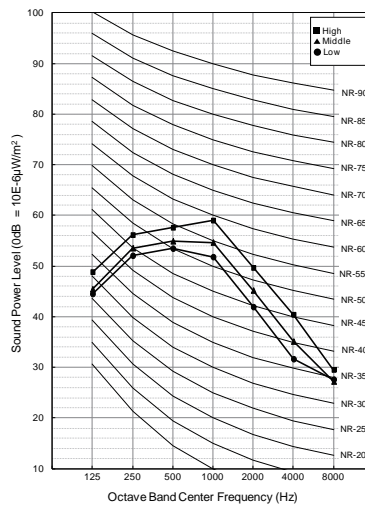

Figure 34: ARNU243SKS4, ARNU303SVA4, and ARNU363SVA4 Sound Power Level Diagrams.

ARNU243SKS4



ARNU303SVA4



ARNU363SVA4

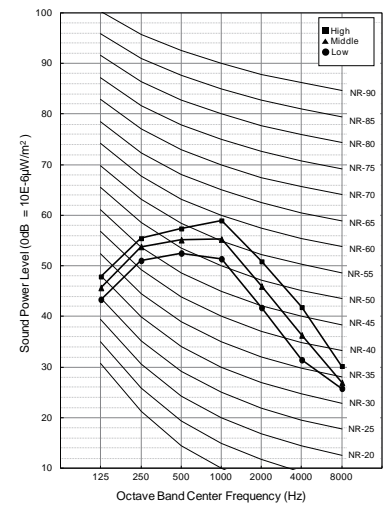
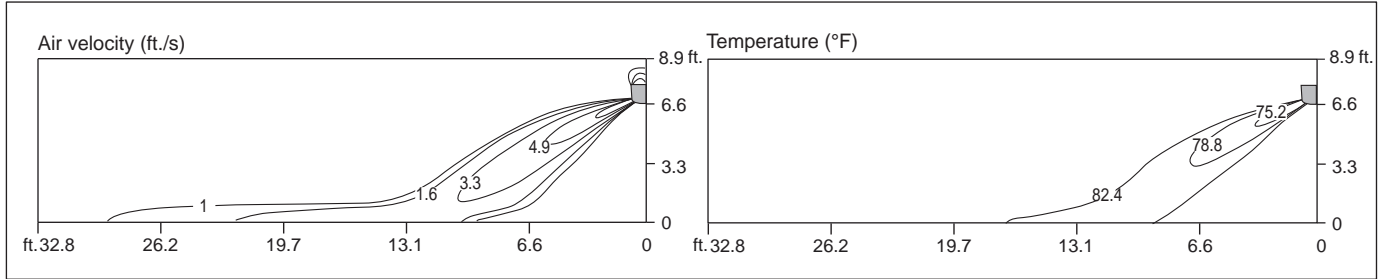

Figure 35: ARNU053SJS4 Cooling.

ARNU053SJS4 Cooling

Side View

Discharge angle: 35°



- Vertical Louver : Center
- Vertical Louver Angle : 0°
- Fan Speed : High

Top View

Discharge angle: 35°

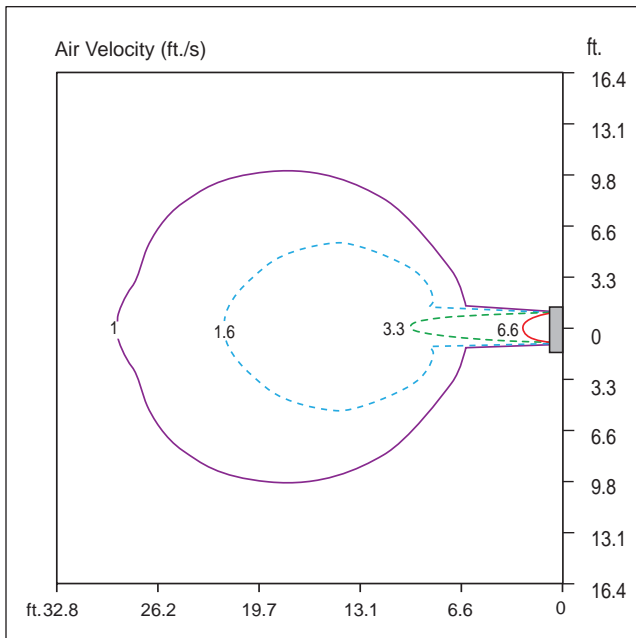

- Vertical Louver : Center
- Vertical Louver Angle : 0°
- Air Speed 1 ft./s Range : 29.2 ft.
- Fan Speed : High

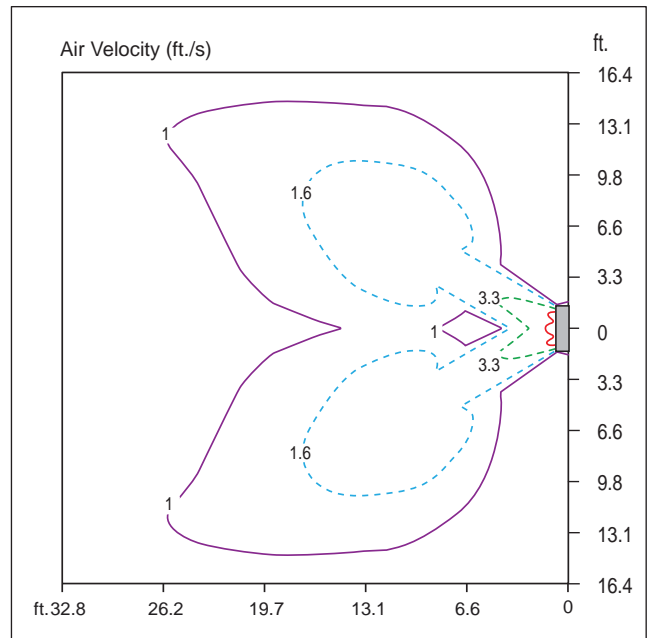

- Vertical Louver : Left and Right
- Vertical Louver Angle : 50°
- Air Speed 1 ft./s Range : 26.2 ft.
- Fan Speed : High

STANDARD WALL-MOUNTED



Air Velocity / Temperature Distribution

ARNU053SJS4

Figure 36: ARNU053SJS4 Heating.

ARNU053SJS4 Heating

Side View

Discharge angle: 55°

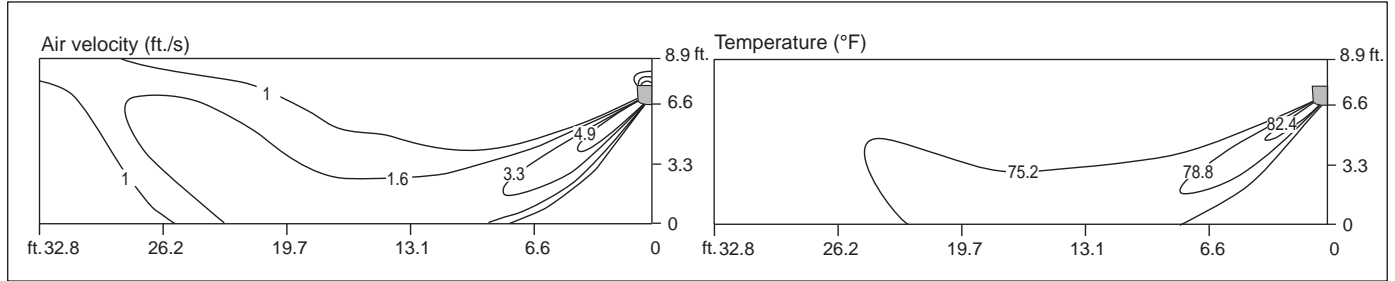

- Vertical Louver : Center
- Vertical Louver Angle : 0°
- Fan Speed : High

Top View

Discharge angle: 55°

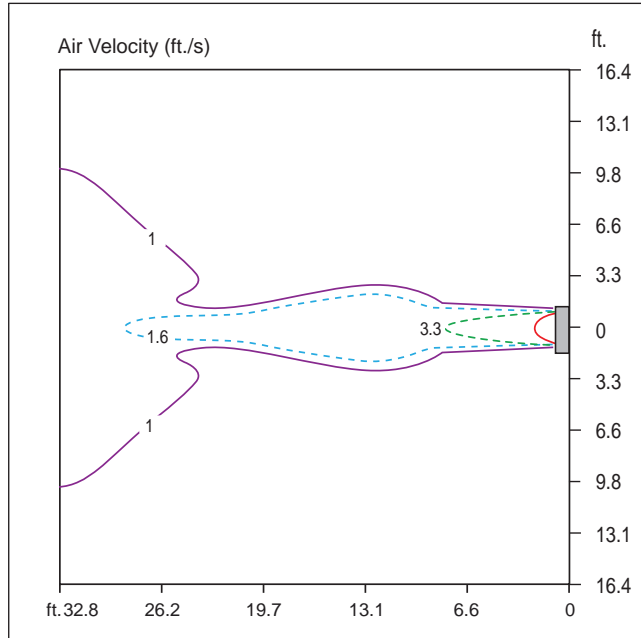

- Vertical Louver : Center
- Vertical Louver Angle : 0°
- Air Speed 1 ft./s Range : 39.0 ft.
- Fan Speed : High

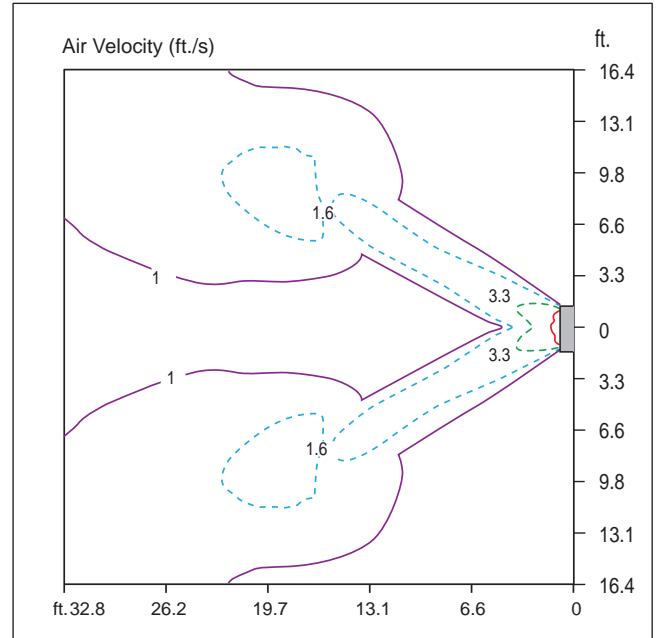

- Vertical Louver : Left and Right
- Vertical Louver Angle : 50°
- Air Speed 1 ft./s Range : 41.3 ft.
- Fan Speed : High

Figure 37: ARNU073SJS4 Cooling.

ARNU073SJS4 Cooling

Side View

Discharge angle: 35°

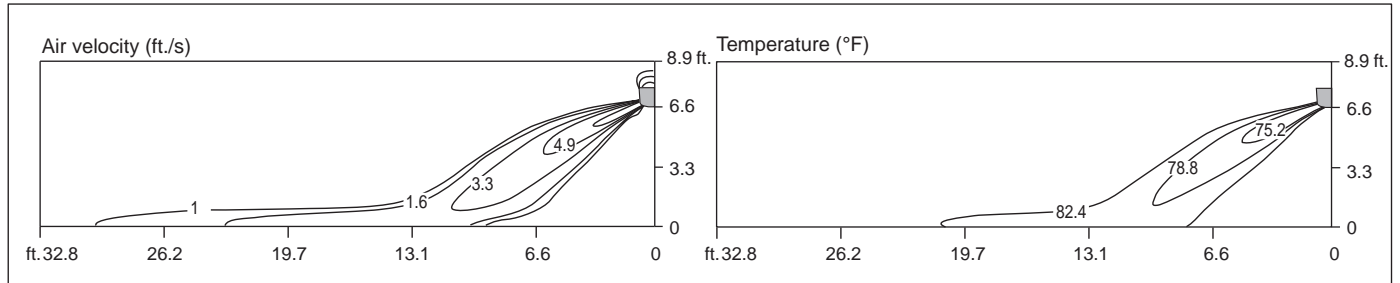

- Vertical Louver : Center
- Vertical Louver Angle : 0°
- Fan Speed : High

Top View

Discharge angle: 35°

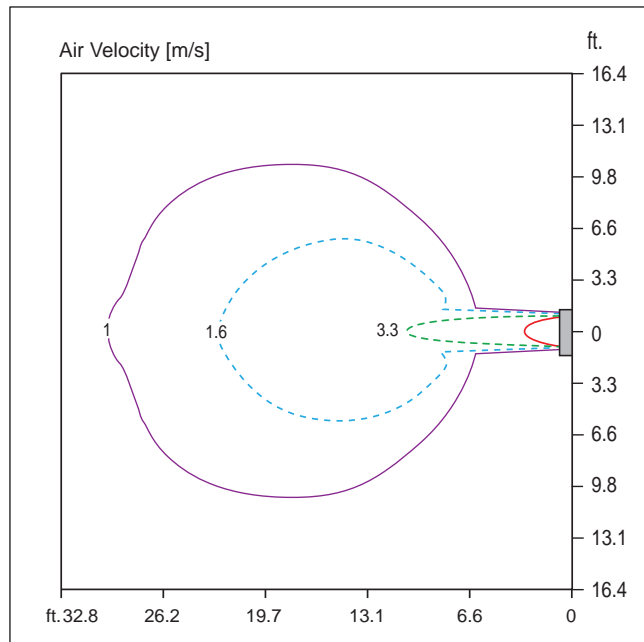

- Vertical Louver : Center
- Vertical Louver Angle : 0°
- Air Speed 1 ft./s Range : 30.2 ft.
- Fan Speed : High

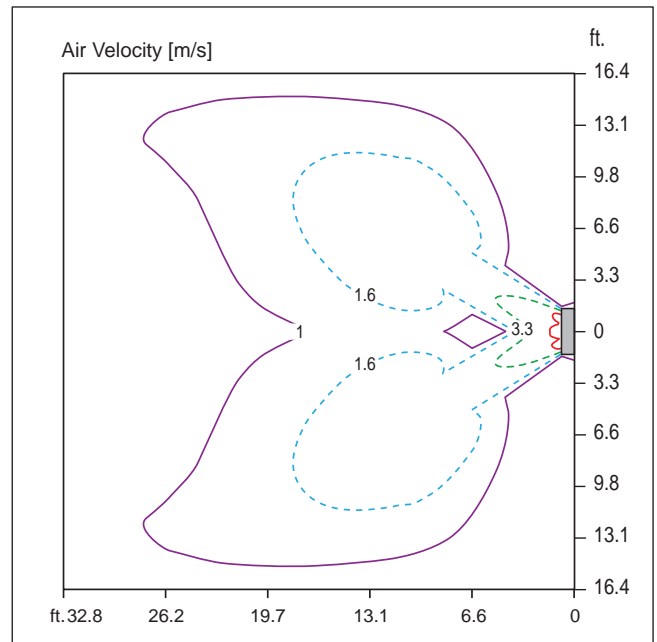

- Vertical Louver : Left and Right
- Vertical Louver Angle : 50°
- Air Speed 1 ft./s Range : 27.6 ft.
- Fan Speed : High

STANDARD WALL-MOUNTED



Air Velocity / Temperature Distribution

ARNU073SJA4

Figure 38: ARNU073SJS4 Heating.

ARNU073SJS4 Heating

Side View

Discharge angle: 55°

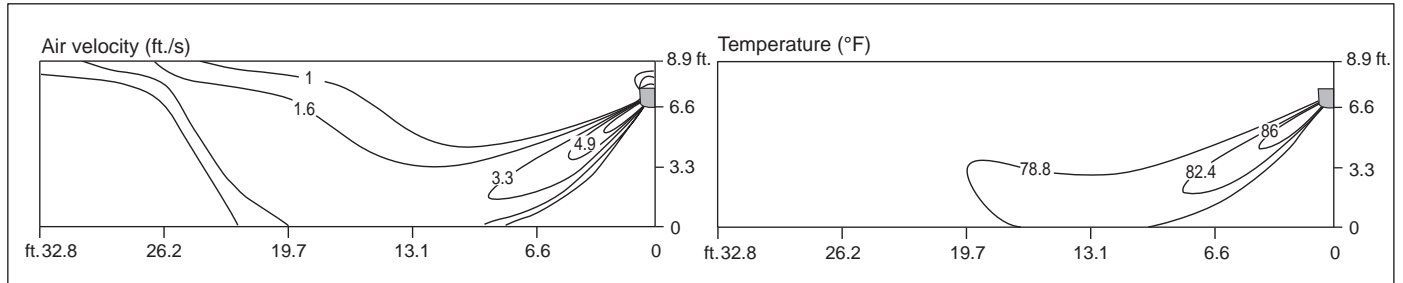

- Vertical Louver : Center
- Vertical Louver Angle : 0°
- Fan Speed : High

Top View

Discharge angle: 55°

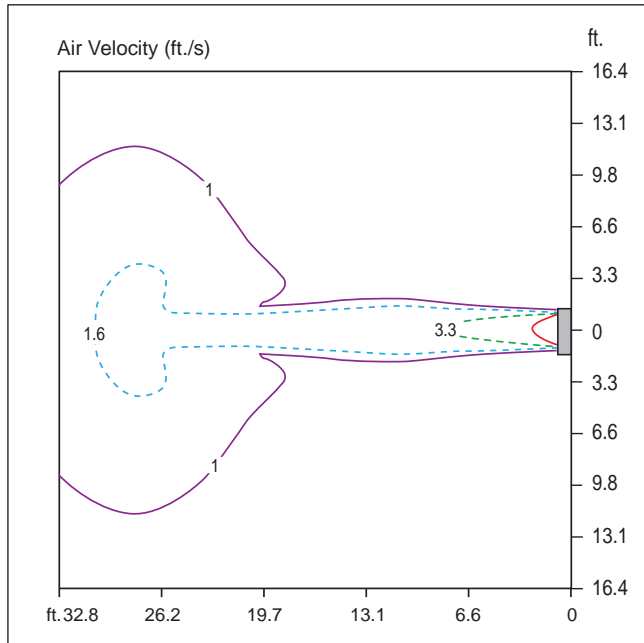

- Vertical Louver : Center
- Vertical Louver Angle : 0°
- Air Speed 1 ft./s Range : 36.1 ft.
- Fan Speed : High

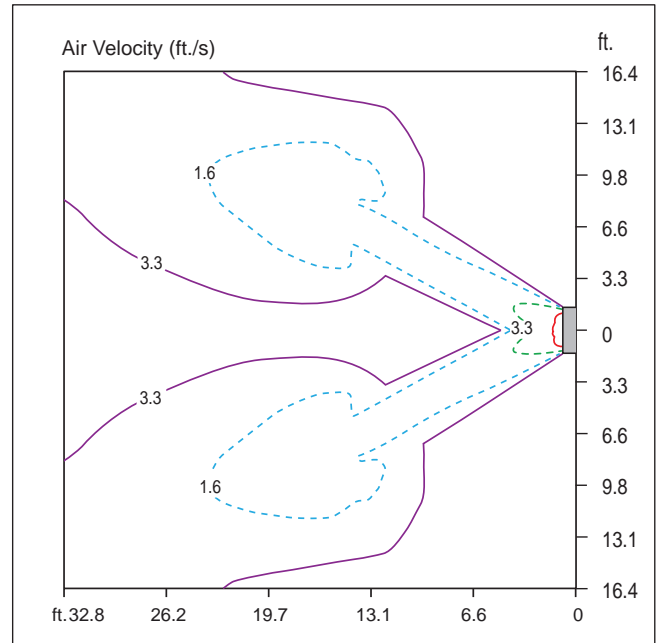

- Vertical Louver : Left and Right
- Vertical Louver Angle : 50°
- Air Speed 1 ft./s Range : 43.3 ft.
- Fan Speed : High

Figure 39: ARNU093SJS4 Cooling.

ARNU093SJS4 Cooling

Side View

Discharge angle: 35°

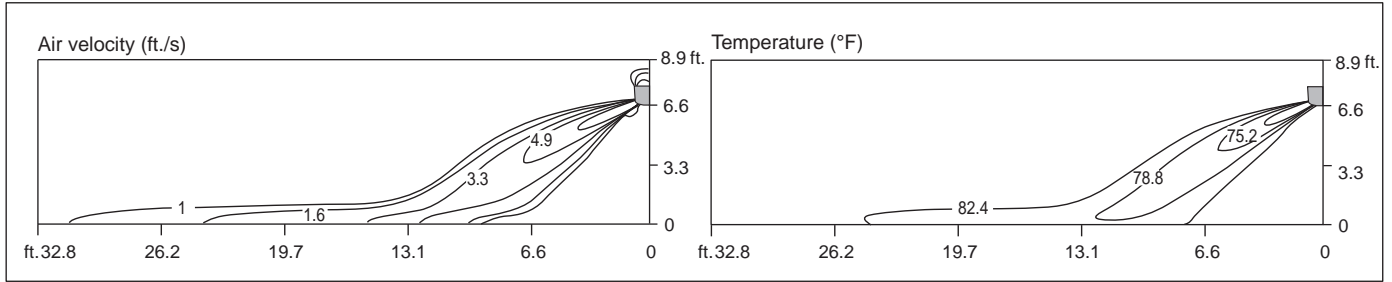

- Vertical Louver : Center
- Vertical Louver Angle : 0°
- Fan Speed : High

Top View

Discharge angle: 35°

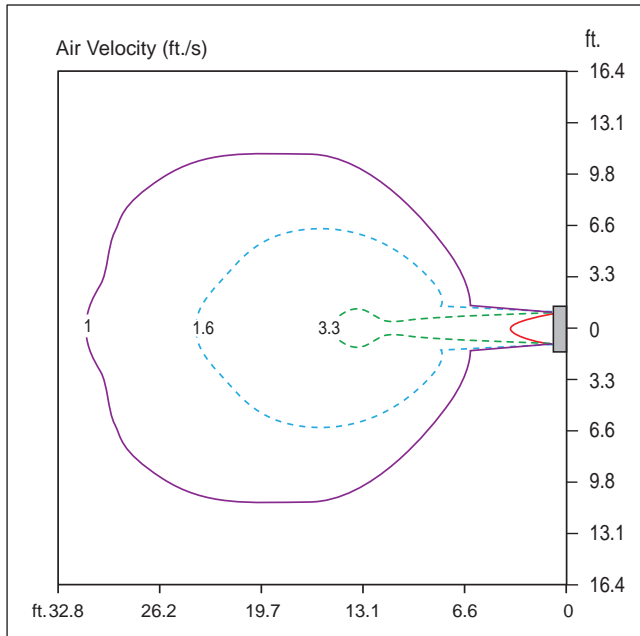

- Vertical Louver : Center
- Vertical Louver Angle : 0°
- Air Speed 1 ft./s Range : 31.5 ft.
- Fan Speed : High

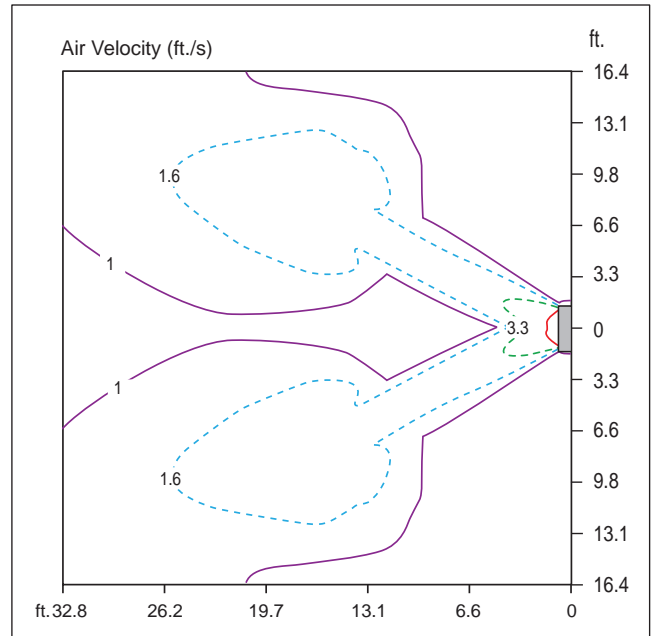

- Vertical Louver : Left and Right
- Vertical Louver Angle : 50°
- Air Speed 1 ft./s Range : 45.9 ft.
- Fan Speed : High

STANDARD WALL-MOUNTED



Air Velocity / Temperature Distribution

ARNU093SJS4

Figure 40: ARNU093SJS4 Heating.

ARNU093SJS4 Heating

Side View

Discharge angle: 55°

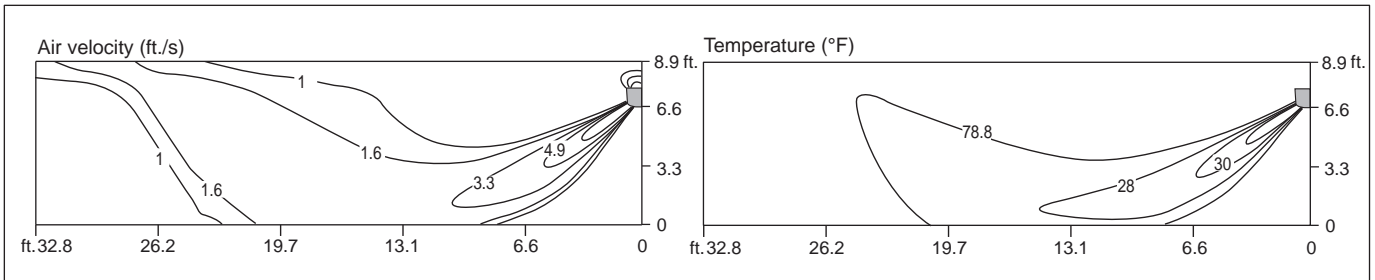

- Vertical Louver : Center
- Vertical Louver Angle : 0°
- Fan Speed : High

Top View

Discharge angle: 55°

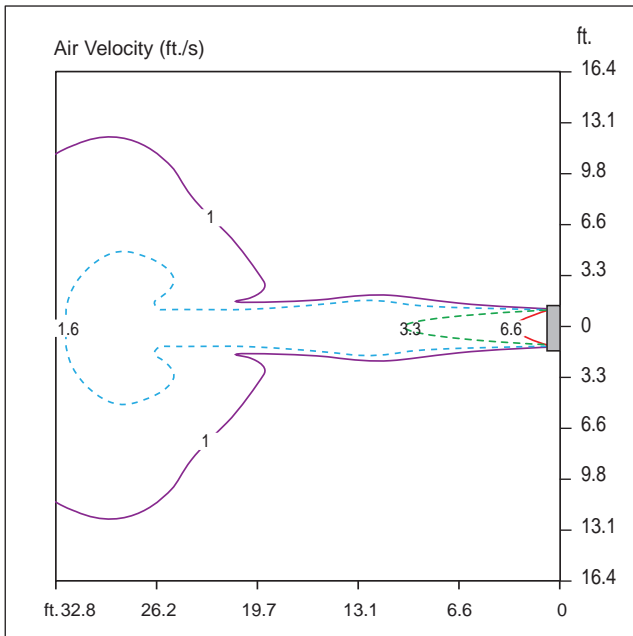

- Vertical Louver : Center
- Vertical Louver Angle : 0°
- Air Speed 1 ft./s Range : 38.7 ft.
- Fan Speed : High

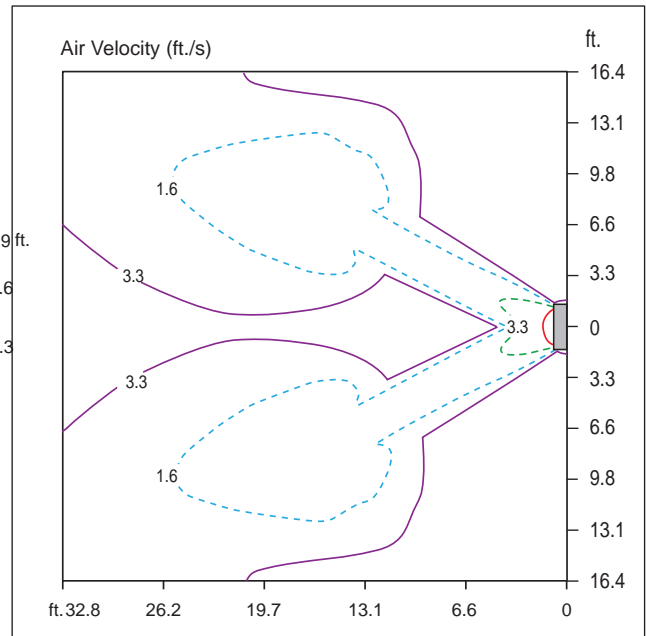

- Vertical Louver : Left and Right
- Vertical Louver Angle : 50°
- Air Speed 1 ft./s Range : 45.9 ft.
- Fan Speed : High

Figure 41: ARNU123SJS4 Cooling.

ARNU123SJS4 Cooling

Side View

Discharge angle: 35°

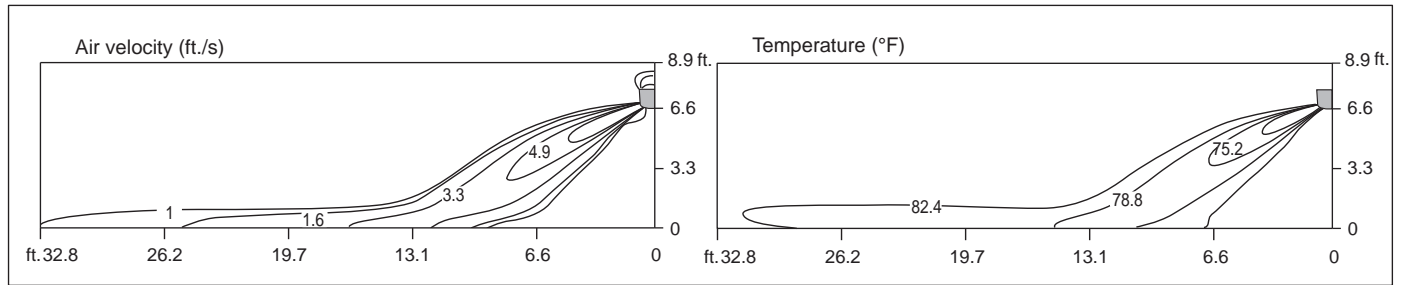

- Vertical Louver : Center
- Vertical Louver Angle : 0°
- Fan Speed : High

Top View

Discharge angle: 35°

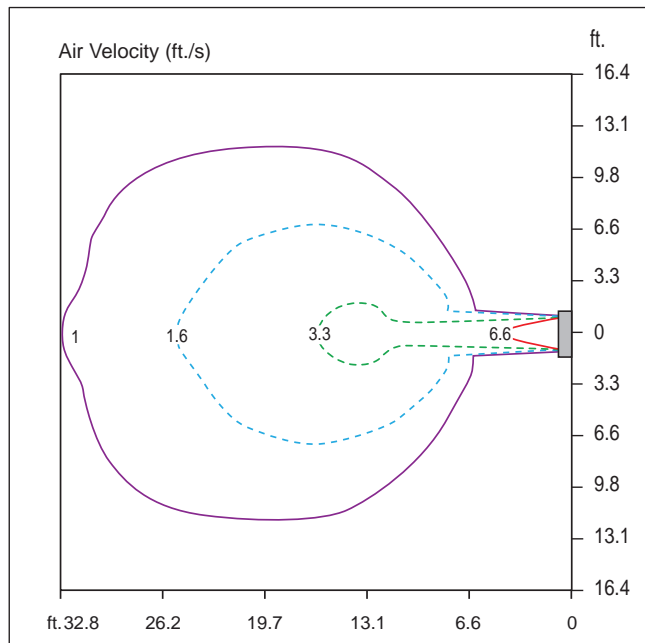

- Vertical Louver : Center
- Vertical Louver Angle : 0°
- Air Speed 1 ft./s Range : 32.8 ft.
- Fan Speed : High

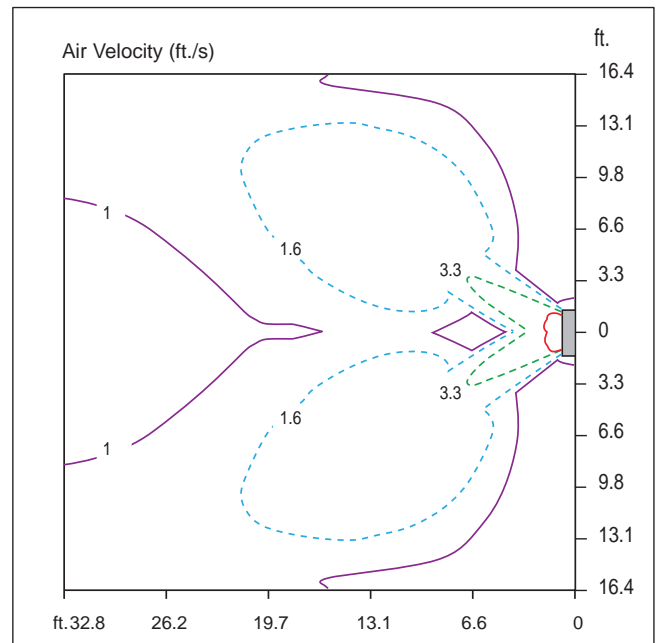

- Vertical Louver : Left and Right
- Vertical Louver Angle : 50°
- Air Speed 1 ft./s Range : 46.9 ft.
- Fan Speed : High

STANDARD WALL-MOUNTED



Air Velocity / Temperature Distribution

ARNU123SJS4

Figure 42: ARNU123SJS4 Heating.

ARNU123SJS4 Heating

Side View

Discharge angle: 55°

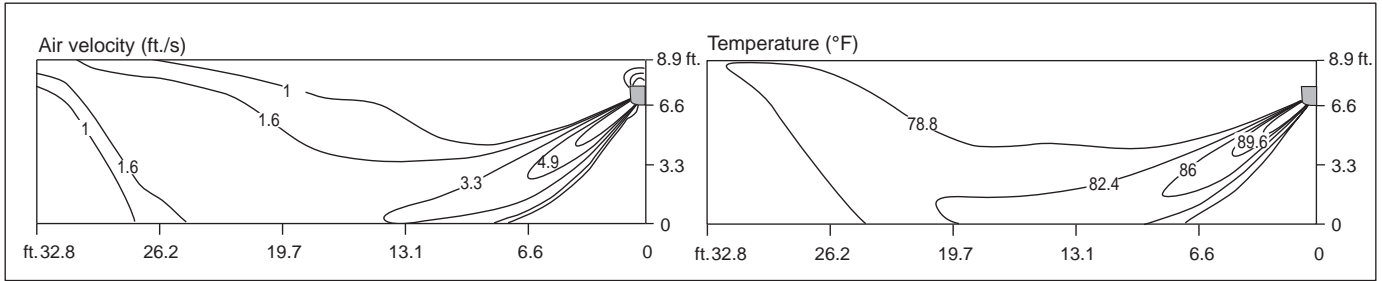

- Vertical Louver : Center
- Vertical Louver Angle : 0°
- Fan Speed : High

Top View

Discharge angle: 55°

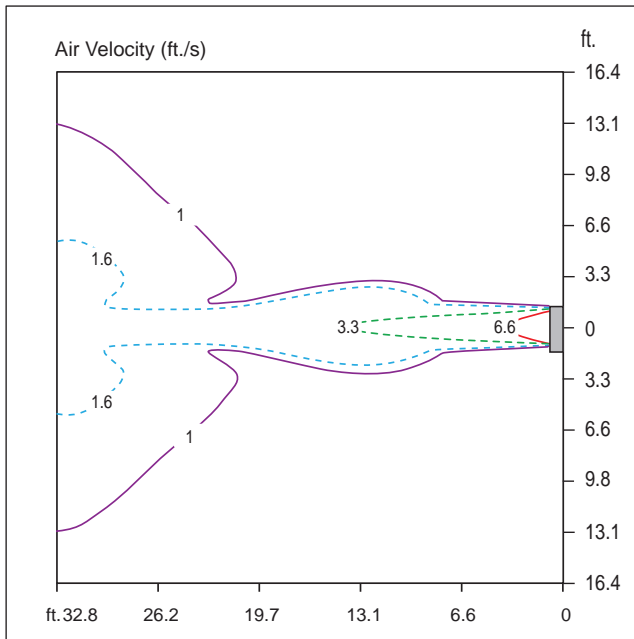

- Vertical Louver : Center
- Vertical Louver Angle : 0°
- Air Speed 1 ft./s Range : 42.6 ft.
- Fan Speed : High

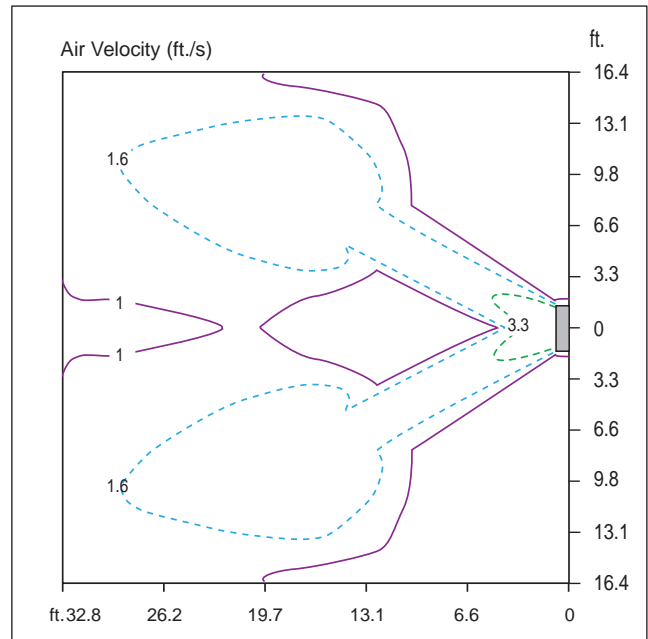

- Vertical Louver : Left and Right
- Vertical Louver Angle : 50°
- Air Speed 1 ft./s Range : 46.9 ft.
- Fan Speed : High

Figure 43: ARNU153SJS4 Cooling.

ARNU153SJS4 Cooling

Side View

Discharge angle: 35°

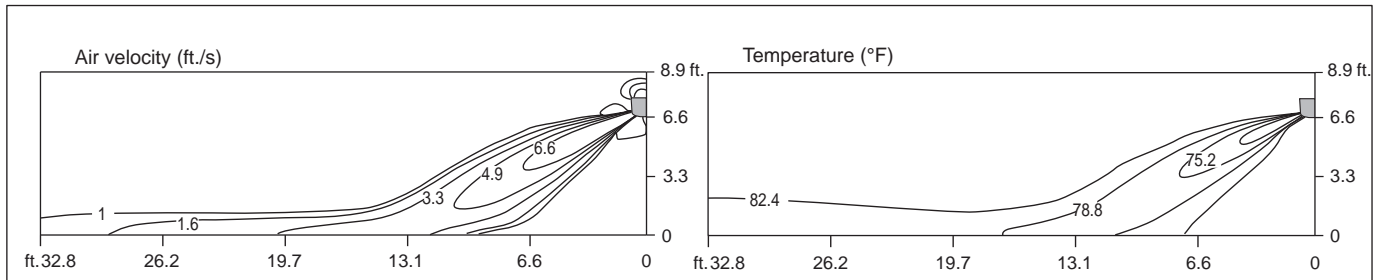

- Vertical Louver : Center
- Vertical Louver Angle : 0°
- Fan Speed : High

Top View

Discharge angle: 35°

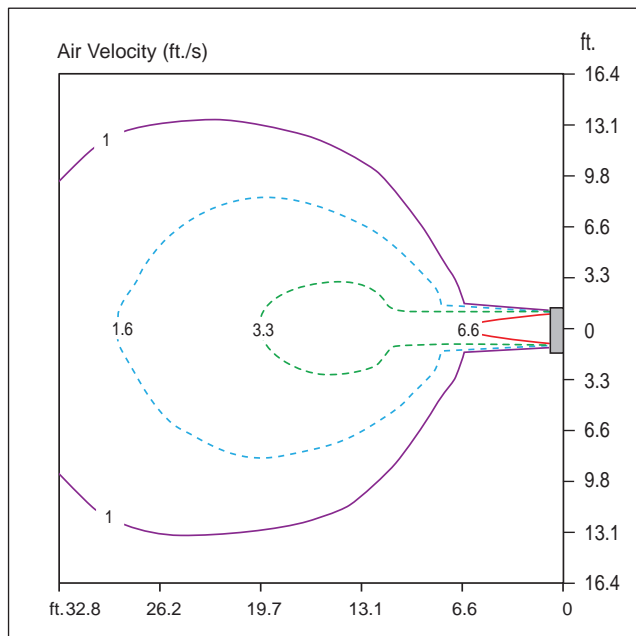

- Vertical Louver : Center
- Vertical Louver Angle : 0°
- Air Speed 1 ft./s Range : 37.7 ft.
- Fan Speed : High

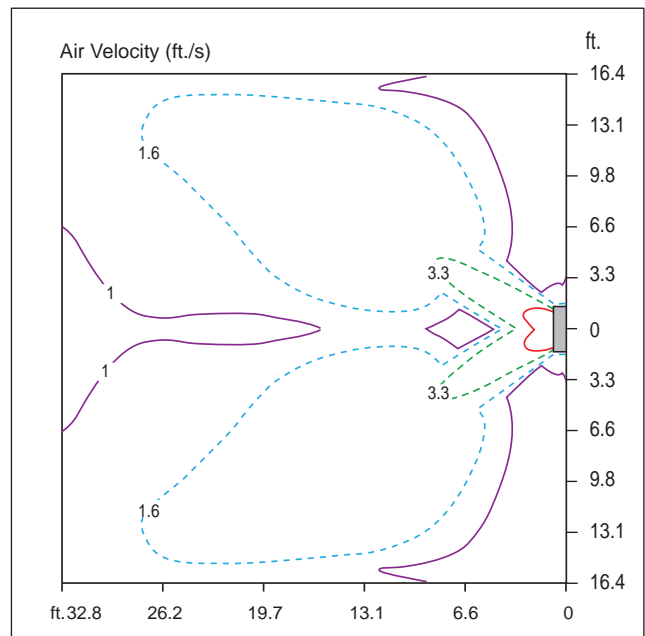

- Vertical Louver : Left and Right
- Vertical Louver Angle : 50°
- Air Speed 1 ft./s Range : 54.8 ft.
- Fan Speed : High

STANDARD WALL-MOUNTED



Air Velocity / Temperature Distribution

ARNU153SJS4

Figure 44: ARNU153SJS4 Heating.

ARNU153SJS4 Heating

Side View

Discharge angle: 55°

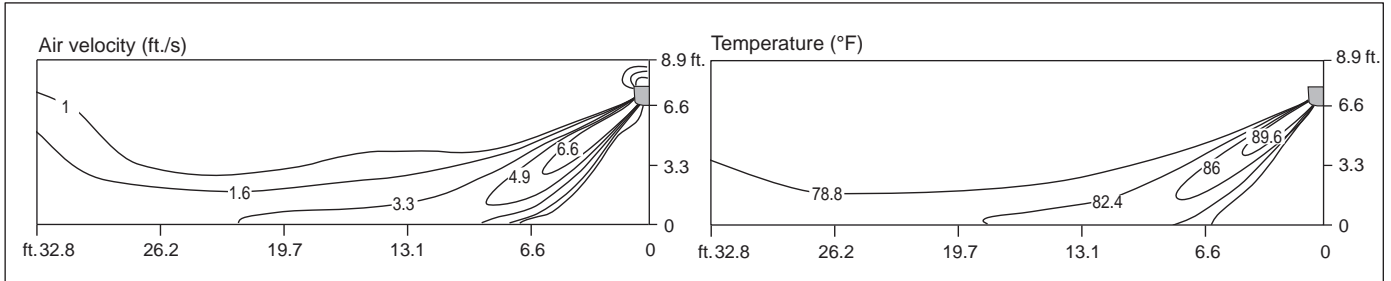

- Vertical Louver : Center
- Vertical Louver Angle : 0°
- Fan Speed : High

Top View

Discharge angle: 55°

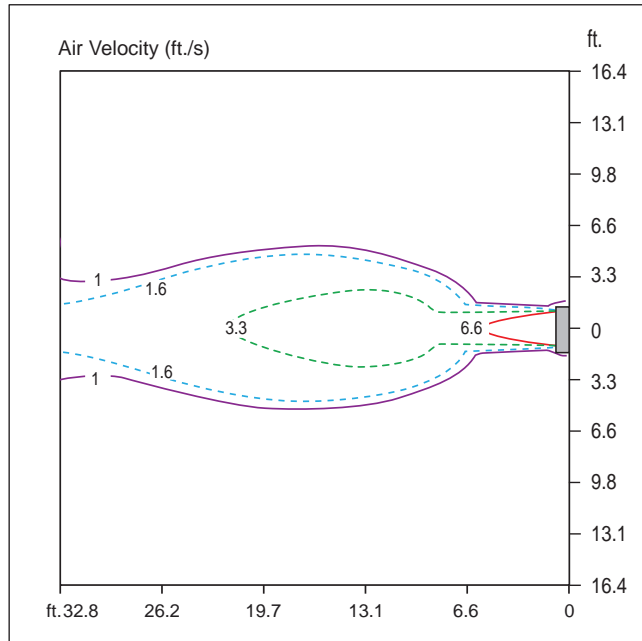

- Vertical Louver : Center
- Vertical Louver Angle : 0°
- Air Speed 1 ft./s Range : 59.1 ft.
- Fan Speed : High

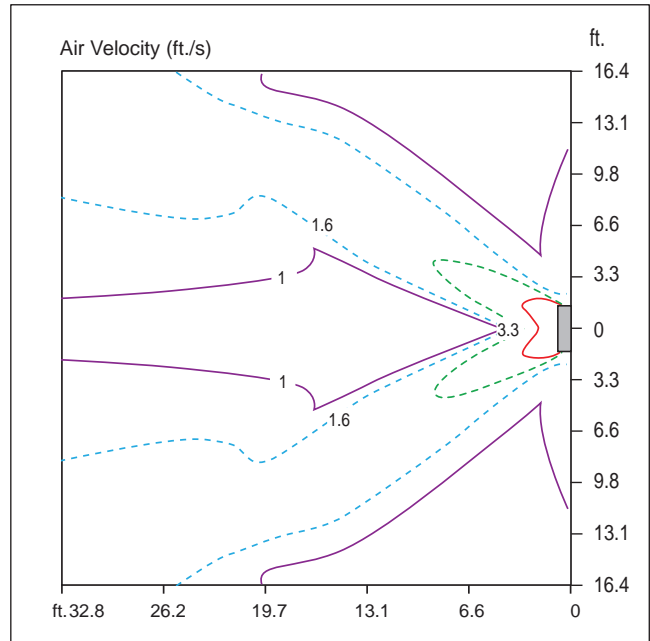

- Vertical Louver : Left and Right
- Vertical Louver Angle : 50°
- Air Speed 1 ft./s Range : 61.7 ft.
- Fan Speed : High

Figure 45: ARNU183SKS4 Cooling.

ARNU183SKS4 Cooling

Side View

Discharge angle: 25°

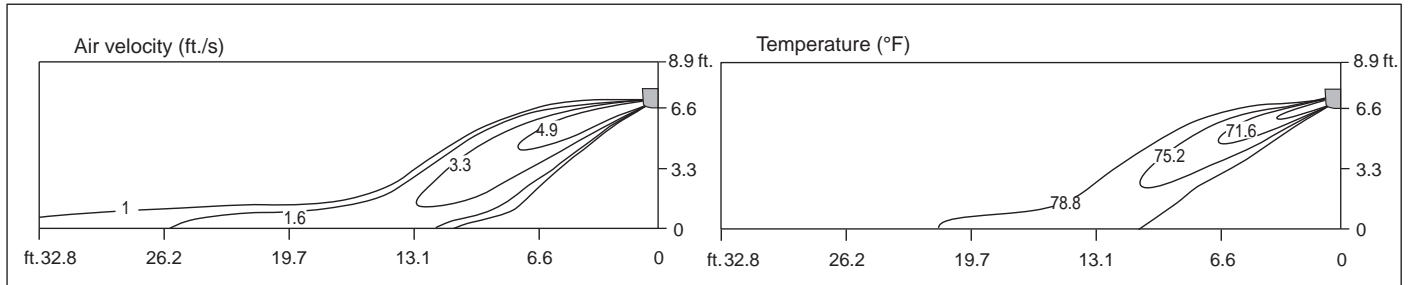

- Vertical Louver : Center
- Vertical Louver Angle : 0°
- Fan Speed : High

Top View

Discharge angle: 25°

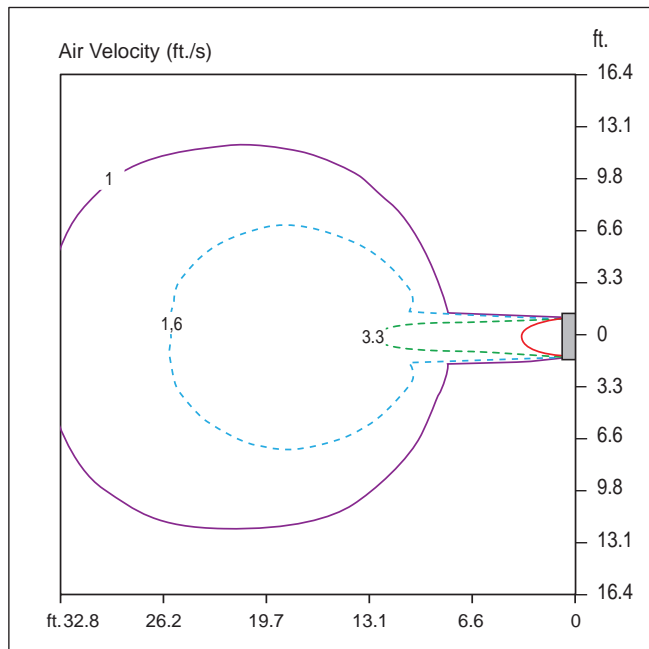

- Vertical Louver : Center
- Vertical Louver Angle : 0°
- Air Speed 1 ft./s Range : 34.1 ft.
- Fan Speed : High

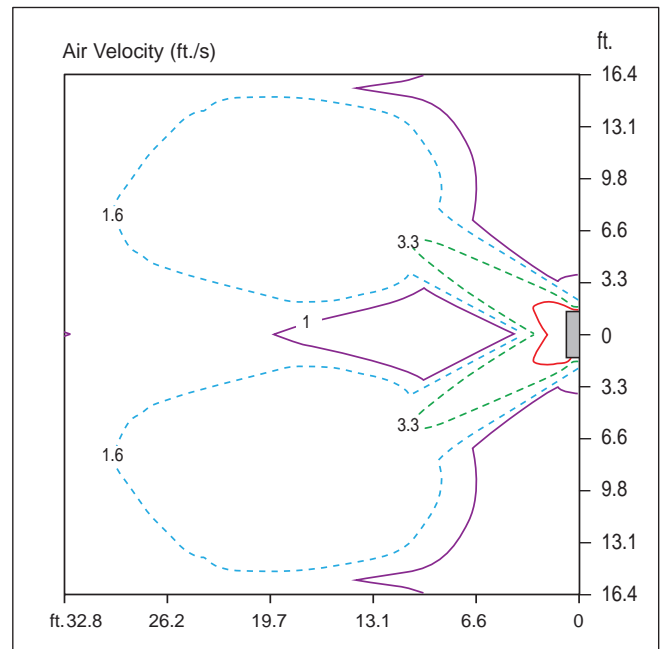

- Vertical Louver : Left and Right
- Vertical Louver Angle : 50°
- Air Speed 1 ft./s Range : 49.9 ft.
- Fan Speed : High

STANDARD WALL-MOUNTED



Air Velocity / Temperature Distribution

ARNU183SKS4

Figure 46: ARNU183SKS4 Heating.

ARNU183SKS4 Heating

Side View

Discharge angle: 45°

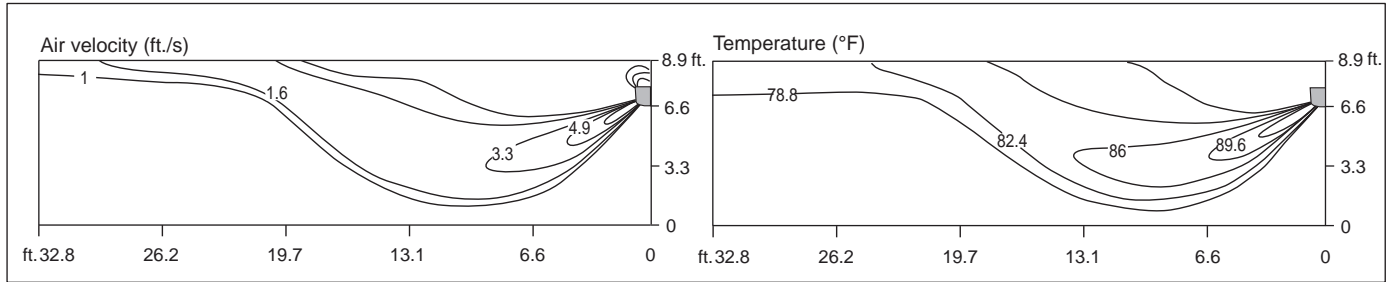

- Vertical Louver : Center
- Vertical Louver Angle : 0°
- Fan Speed : High

Top View

Discharge angle: 45°

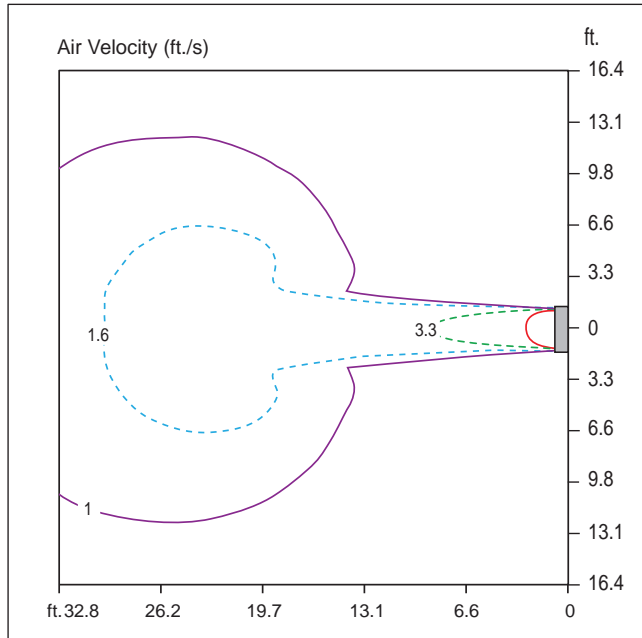

- Vertical Louver : Center
- Vertical Louver Angle : 0°
- Air Speed 1 ft./s Range : 38.1 ft.
- Fan Speed : High

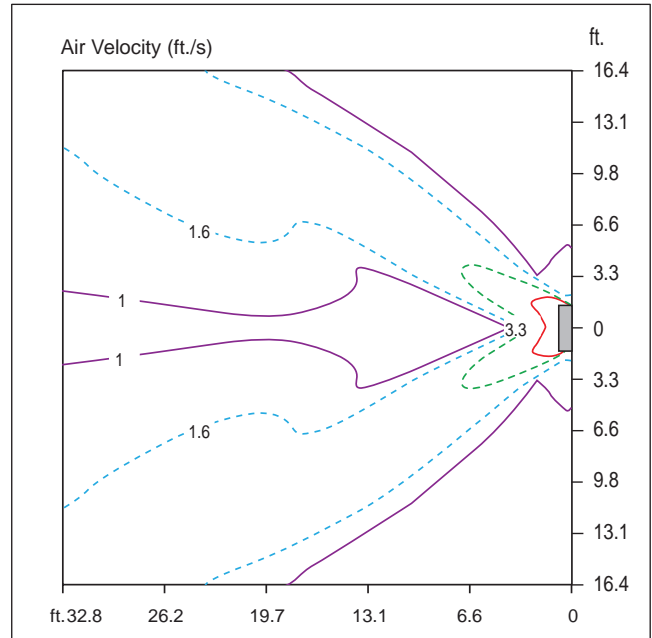

- Vertical Louver : Left and Right
- Vertical Louver Angle : 50°
- Air Speed 1 ft./s Range : 59.7 ft.
- Fan Speed : High

Figure 47: ARNU243SKS4 Cooling.

ARNU243SKS4 Cooling

Side View

Discharge angle: 25°

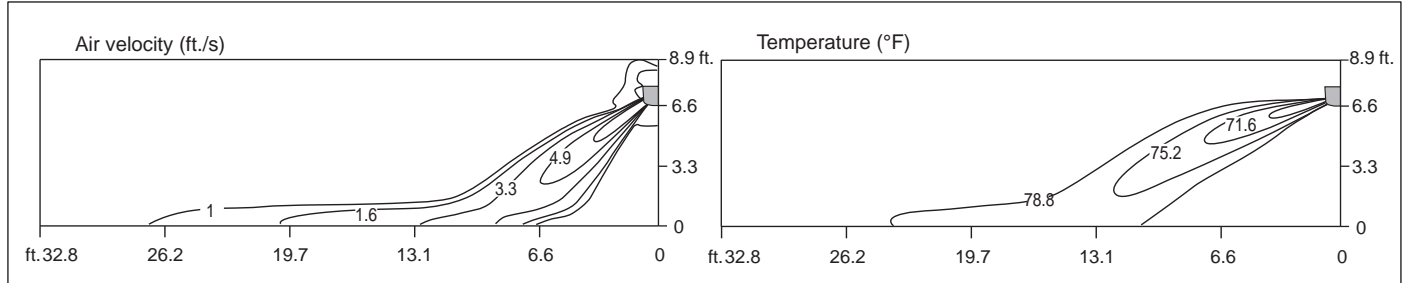

- Vertical Louver : Center
- Vertical Louver Angle : 0°
- Fan Speed : High

Top View

Discharge angle: 25°

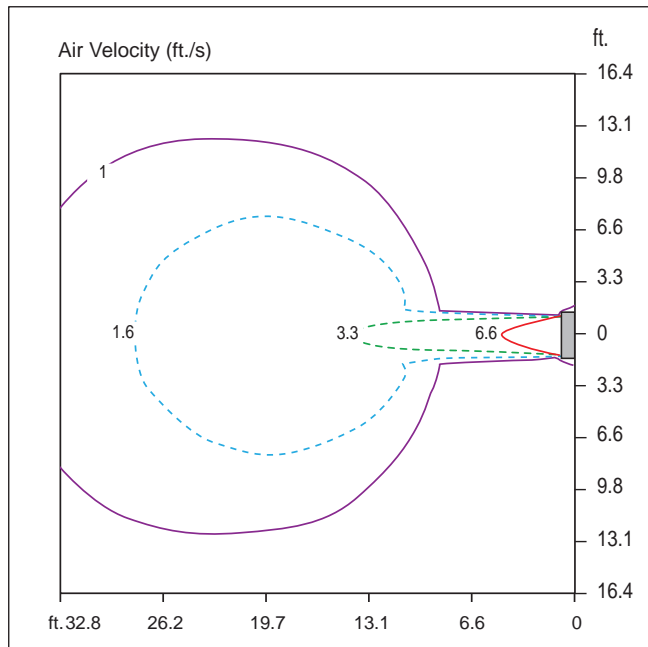

- Vertical Louver : Center
- Vertical Louver Angle : 0°
- Air Speed 1 ft./s Range : 36.7 ft.
- Fan Speed : High

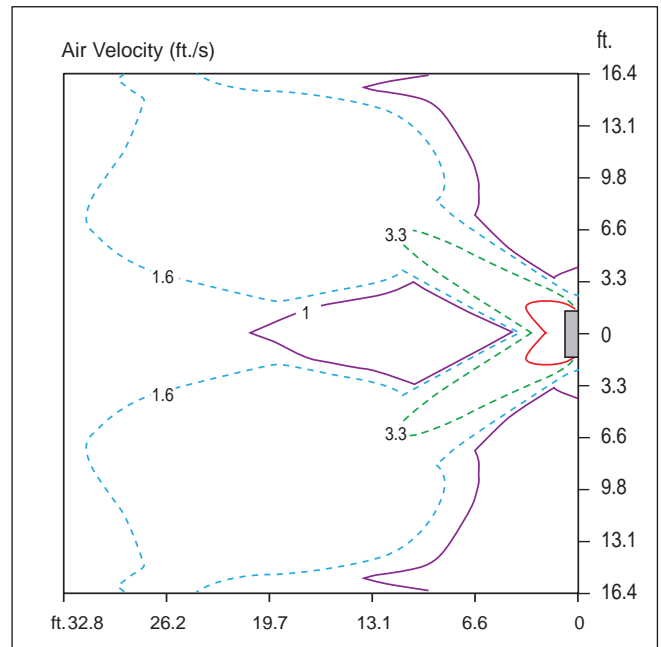

- Vertical Louver : Left and Right
- Vertical Louver Angle : 50°
- Air Speed 1 ft./s Range : 54.1 ft.
- Fan Speed : High

STANDARD WALL-MOUNTED



Air Velocity / Temperature Distribution

ARNU243SKS4

Figure 48: ARNU243SKS4 Heating.

ARNU243SKS4 Heating

Side View

Discharge angle: 45°

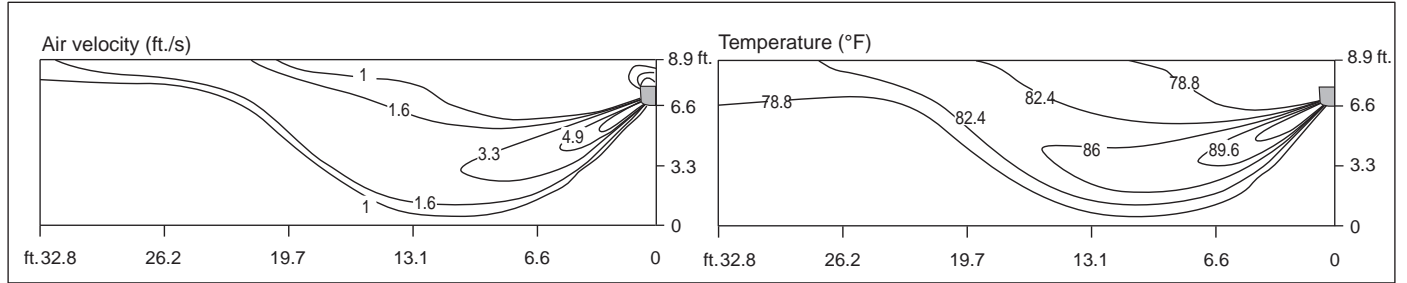

- Vertical Louver : Center
- Vertical Louver Angle : 0°
- Fan Speed : High

Top View

Discharge angle: 45°

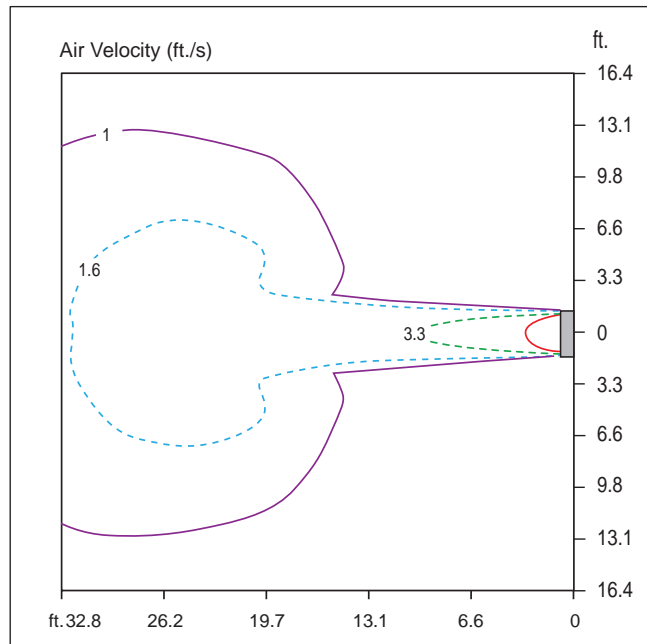

- Vertical Louver : Center
- Vertical Louver Angle : 0°
- Air Speed 1 ft./s Range : 39.7 ft.
- Fan Speed : High

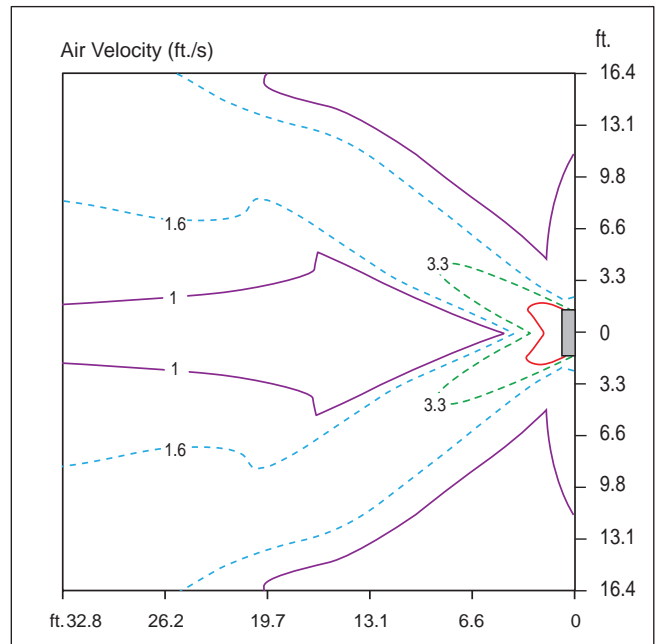

- Vertical Louver : Left and Right
- Vertical Louver Angle : 50°
- Air Speed 1 ft./s Range : 49.9 ft.
- Fan Speed : High

ARNU303SVA4

Cooling

Heating

Discharge angle: 25°

Discharge angle: 35°

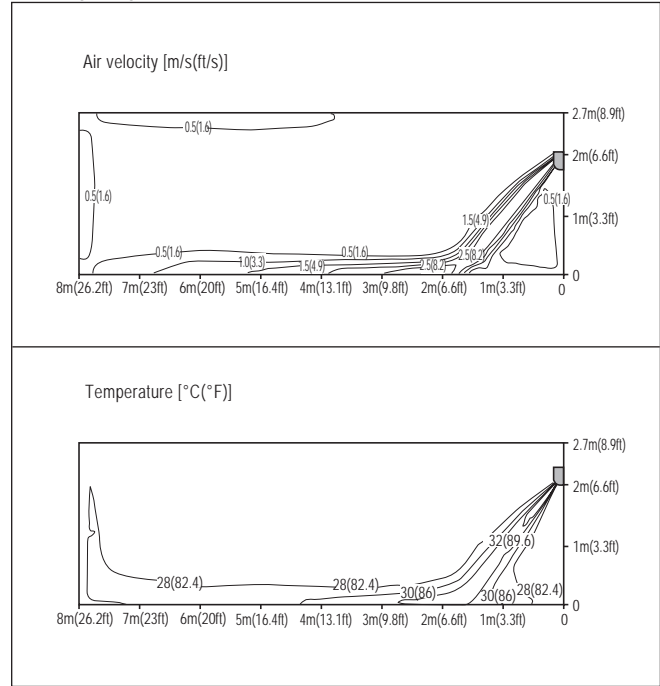
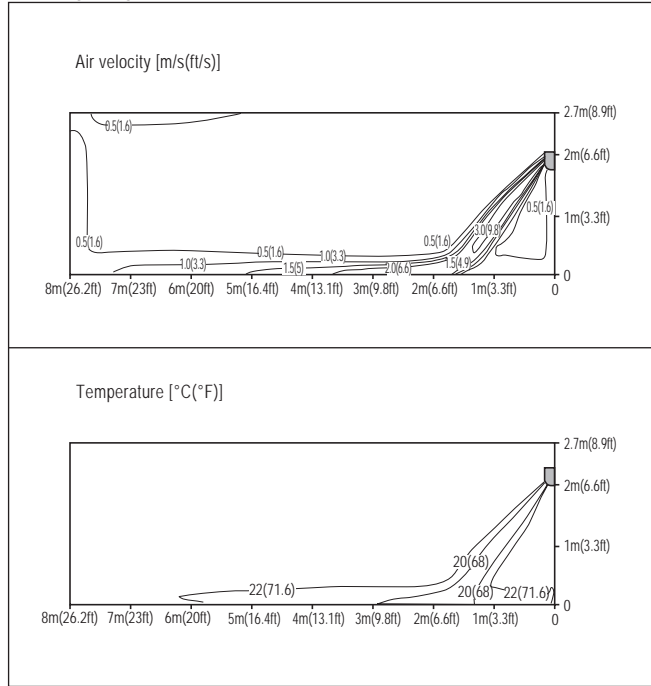

ARNU363SVA4

Cooling

Heating

Discharge angle: 25°

Discharge angle: 35°

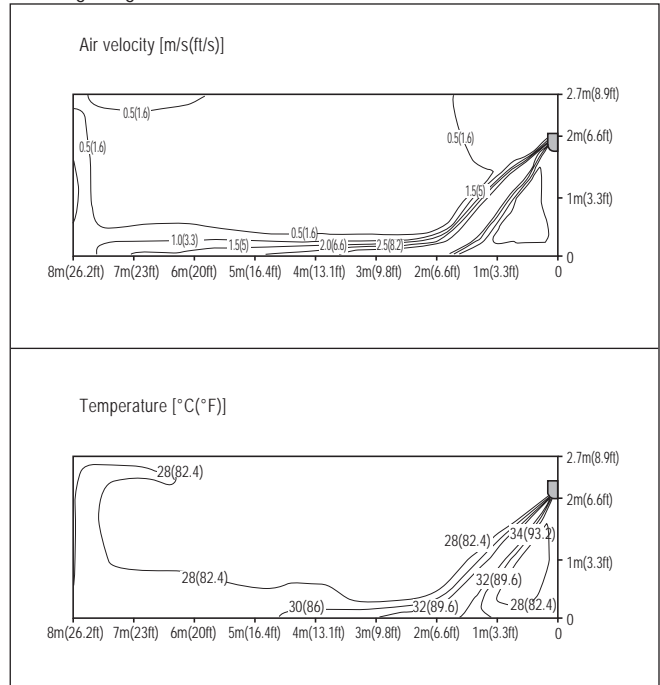
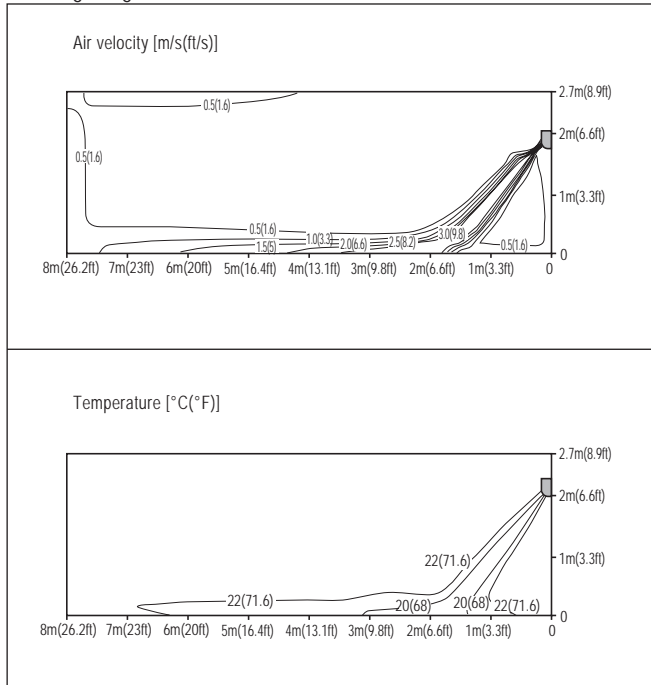

Standard Wall-Mounted

STANDARD WALL-MOUNTED



Cooling Capacity Tables

ARNU053SJS4

Table 42: ARNU053SJS4 Cooling Capacity Table.

Model No. / Capacity Index	Outdoor Air Temp. (°F DB)	Indoor Air Temperature (°F DB / WB)													
		68 / 57		73 / 61		79 / 64		80 / 67		85 / 70		88 / 73		91 / 76	
		TC	SHC	TC	SHC	TC	SHC	TC	SHC	TC	SHC	TC	SHC	TC	SHC
ARNU053SJS4/ 5.5	-9.9	3.6	3.7	4.4	4.3	5.0	4.6	5.5	4.9	6.2	5.3	6.6	5.2	7.1	5.2
	-5	3.6	3.7	4.4	4.3	5.0	4.6	5.5	4.9	6.2	5.3	6.6	5.2	7.1	5.2
	0	3.6	3.7	4.4	4.3	5.0	4.6	5.5	4.9	6.2	5.3	6.6	5.2	7.1	5.2
	5	3.6	3.7	4.4	4.3	5.0	4.6	5.5	4.9	6.2	5.3	6.6	5.2	7.1	5.2
	10	3.6	3.7	4.4	4.3	5.0	4.6	5.5	4.9	6.2	5.3	6.6	5.2	7.1	5.2
	14	3.6	3.7	4.4	4.3	5.0	4.6	5.5	4.9	6.2	5.3	6.6	5.2	7.1	5.2
	20	3.6	3.7	4.4	4.3	5.0	4.6	5.5	4.9	6.2	5.3	6.6	5.2	7.1	5.2
	23	3.6	3.7	4.4	4.3	5.0	4.6	5.5	4.9	6.2	5.3	6.6	5.2	7.1	5.2
	25	3.6	3.7	4.4	4.3	5.0	4.6	5.5	4.9	6.2	5.3	6.6	5.2	7.1	5.2
	30	3.6	3.7	4.4	4.3	5.0	4.6	5.5	4.9	6.2	5.3	6.6	5.2	7.1	5.2
	35	3.6	3.7	4.4	4.3	5.0	4.6	5.5	4.9	6.2	5.3	6.6	5.2	7.1	5.2
	40	3.6	3.7	4.4	4.3	5.0	4.6	5.5	4.9	6.2	5.3	6.6	5.2	7.1	5.2
	45	3.6	3.7	4.4	4.3	5.0	4.6	5.5	4.9	6.2	5.3	6.6	5.2	7.1	5.2
	50	3.6	3.7	4.4	4.3	5.0	4.6	5.5	4.9	6.2	5.3	6.6	5.2	7.1	5.2
	55	3.6	3.7	4.4	4.3	5.0	4.6	5.5	4.9	6.2	5.3	6.6	5.2	7.1	5.2
	60	3.6	3.7	4.4	4.3	5.0	4.6	5.5	4.9	6.2	5.3	6.6	5.2	7.0	5.2
	65	3.6	3.7	4.4	4.3	5.0	4.6	5.5	4.9	6.2	5.3	6.6	5.2	6.9	5.1
	70	3.6	3.7	4.4	4.3	5.0	4.6	5.5	4.9	6.2	5.3	6.6	5.2	6.8	5.0
	75	3.6	3.7	4.4	4.3	5.0	4.6	5.5	4.9	6.2	5.3	6.6	5.2	6.6	4.9
	80	3.6	3.7	4.4	4.3	5.0	4.6	5.5	4.9	6.2	5.3	6.4	5.2	6.5	4.9
85	3.6	3.7	4.4	4.3	5.0	4.6	5.5	4.9	6.1	5.2	6.2	5.0	6.3	4.7	
90	3.6	3.7	4.4	4.3	5.0	4.6	5.5	4.9	6.0	5.1	6.1	4.9	6.2	4.6	
95	3.6	3.7	4.4	4.3	5.0	4.6	5.5	4.9	5.9	5.1	6.0	4.9	6.1	4.6	
100	3.6	3.7	4.4	4.3	5.0	4.6	5.5	4.9	5.8	5.0	5.9	4.8	6.0	4.5	
105	3.6	3.7	4.2	4.1	4.7	4.4	5.3	4.7	5.5	4.7	5.7	4.6	5.8	4.4	
110	3.5	3.6	4.0	3.9	4.4	4.1	5.0	4.4	5.2	4.4	5.4	4.4	5.6	4.3	
115	3.4	3.5	3.8	3.7	4.1	3.9	4.7	4.2	4.9	4.2	5.1	4.2	5.4	4.1	
118	3.4	3.4	3.6	3.5	3.9	3.6	4.5	4.0	4.6	4.0	4.9	4.0	5.2	4.0	
122	3.3	3.3	3.4	3.3	3.7	3.4	4.2	3.8	4.4	3.8	4.6	3.8	5.0	3.8	

TC: Total Capacity (MBh); SHC: Sensible Heat Capacity (MBh).
 Cooling range with the Low Ambient Baffle Kit (sold separately) installed on the outdoor unit(s) is -9.9°F to +122°F, and is achieved only when all indoor units are operating in cooling mode. Does not impact heat recovery system synchronous operating range. The System Combination Ratio must be between 50–130%.

Rated capacity is certified under AHRI Standard 1230. Ratings are subject to change without notice.
 Current certified ratings are available at www.ahridirectory.org.
 For outdoor unit performance data, see the respective outdoor unit performance data manuals on <https://lghvac.com/commercial>.

Note:

Low ambient performance with LGRED° heat technology is included in Multi V 5 Air Source Units produced after February 2019.



Table 43: ARNU073SJS4 Cooling Capacity Table.

Model No. / Capacity Index	Outdoor Air Temp. (°F DB)	Indoor Air Temperature (°F DB / WB)													
		68 / 57		73 / 61		79 / 64		80 / 67		85 / 70		88 / 73		91 / 76	
		TC	SHC	TC	SHC	TC	SHC	TC	SHC	TC	SHC	TC	SHC	TC	SHC
ARNU073SJS4/ 7.5	-9.9	4.9	4.7	6.0	5.4	6.8	5.7	7.5	6.1	8.4	6.6	8.9	6.5	9.7	6.5
	-5	4.9	4.7	6.0	5.4	6.8	5.7	7.5	6.1	8.4	6.6	8.9	6.5	9.7	6.5
	0	4.9	4.7	6.0	5.4	6.8	5.7	7.5	6.1	8.4	6.6	8.9	6.5	9.7	6.5
	5	4.9	4.7	6.0	5.4	6.8	5.7	7.5	6.1	8.4	6.6	8.9	6.5	9.7	6.5
	10	4.9	4.7	6.0	5.4	6.8	5.7	7.5	6.1	8.4	6.6	8.9	6.5	9.7	6.5
	14	4.9	4.7	6.0	5.4	6.8	5.7	7.5	6.1	8.4	6.6	8.9	6.5	9.7	6.5
	20	4.9	4.7	6.0	5.4	6.8	5.7	7.5	6.1	8.4	6.6	8.9	6.5	9.7	6.5
	23	4.9	4.7	6.0	5.4	6.8	5.7	7.5	6.1	8.4	6.6	8.9	6.5	9.7	6.5
	25	4.9	4.7	6.0	5.4	6.8	5.7	7.5	6.1	8.4	6.6	8.9	6.5	9.7	6.5
	30	4.9	4.7	6.0	5.4	6.8	5.7	7.5	6.1	8.4	6.6	8.9	6.5	9.7	6.5
	35	4.9	4.7	6.0	5.4	6.8	5.7	7.5	6.1	8.4	6.6	8.9	6.5	9.7	6.5
	40	4.9	4.7	6.0	5.4	6.8	5.7	7.5	6.1	8.4	6.6	8.9	6.5	9.7	6.5
	45	4.9	4.7	6.0	5.4	6.8	5.7	7.5	6.1	8.4	6.6	8.9	6.5	9.7	6.5
	50	4.9	4.7	6.0	5.4	6.8	5.7	7.5	6.1	8.4	6.6	8.9	6.5	9.7	6.5
	55	4.9	4.7	6.0	5.4	6.8	5.7	7.5	6.1	8.4	6.6	8.9	6.5	9.7	6.5
	60	4.9	4.7	6.0	5.4	6.8	5.7	7.5	6.1	8.4	6.6	8.9	6.5	9.6	6.4
	65	4.9	4.7	6.0	5.4	6.8	5.7	7.5	6.1	8.4	6.6	8.9	6.5	9.4	6.3
	70	4.9	4.7	6.0	5.4	6.8	5.7	7.5	6.1	8.4	6.6	8.9	6.5	9.3	6.2
	75	4.9	4.7	6.0	5.4	6.8	5.7	7.5	6.1	8.4	6.6	8.9	6.5	9.1	6.1
	80	4.9	4.7	6.0	5.4	6.8	5.7	7.5	6.1	8.4	6.6	8.7	6.4	8.8	6.1
85	4.9	4.7	6.0	5.4	6.8	5.7	7.5	6.1	8.3	6.5	8.4	6.2	8.6	5.8	
90	4.9	4.7	6.0	5.4	6.8	5.7	7.5	6.1	8.2	6.4	8.3	6.1	8.4	5.8	
95	4.9	4.7	6.0	5.4	6.8	5.7	7.5	6.1	8.0	6.3	8.2	6.0	8.3	5.7	
100	4.9	4.7	6.0	5.4	6.8	5.7	7.5	6.1	7.9	6.2	8.0	6.0	8.2	5.7	
105	4.9	4.7	5.7	5.1	6.4	5.5	7.2	5.8	7.5	5.8	7.7	5.8	7.9	5.5	
110	4.8	4.5	5.4	4.8	6.0	5.1	6.8	5.5	7.1	5.5	7.3	5.5	7.7	5.4	
115	4.7	4.4	5.1	4.6	5.6	4.8	6.3	5.2	6.6	5.2	7.0	5.2	7.4	5.1	
118	4.6	4.3	4.9	4.4	5.4	4.5	6.1	5.0	6.3	5.0	6.7	5.0	7.1	4.9	
122	4.5	4.1	4.6	4.1	5.1	4.2	5.8	4.7	6.0	4.7	6.3	4.7	6.8	4.7	

Standard Wall-Mounted

TC: Total Capacity (MBh); SHC: Sensible Heat Capacity (MBh).
 Cooling range with the Low Ambient Baffle Kit (sold separately) installed on the outdoor unit(s) is -9.9°F to +122°F, and is achieved only when all indoor units are operating in cooling mode. Does not impact heat recovery system synchronous operating range. The System Combination Ratio must be between 50–130%.

Rated capacity is certified under AHRI Standard 1230. Ratings are subject to change without notice.
 Current certified ratings are available at www.ahridirectory.org.
 For outdoor unit performance data, see the respective outdoor unit performance data manuals on <https://lghvac.com/commercial>.

Note:
 Low ambient performance with LGRED° heat technology is included in Multi V 5 Air Source Units produced after February 2019.

STANDARD WALL-MOUNTED



Cooling Capacity Tables

ARNU093SJS4

Table 44: ARNU093SJS4 Cooling Capacity Table.

Model No. / Capacity Index	Outdoor Air Temp. (°F DB)	Indoor Air Temperature (°F DB / WB)													
		68 / 57		73 / 61		79 / 64		80 / 67		85 / 70		88 / 73		91 / 76	
		TC	SHC	TC	SHC	TC	SHC	TC	SHC	TC	SHC	TC	SHC	TC	SHC
ARNU093SJS4 / 9.6	-9.9	6.3	5.6	7.7	6.4	8.6	6.8	9.6	7.3	10.8	7.8	11.4	7.7	12.4	7.7
	-5	6.3	5.6	7.7	6.4	8.6	6.8	9.6	7.3	10.8	7.8	11.4	7.7	12.4	7.7
	0	6.3	5.6	7.7	6.4	8.6	6.8	9.6	7.3	10.8	7.8	11.4	7.7	12.4	7.7
	5	6.3	5.6	7.7	6.4	8.6	6.8	9.6	7.3	10.8	7.8	11.4	7.7	12.4	7.7
	10	6.3	5.6	7.7	6.4	8.6	6.8	9.6	7.3	10.8	7.8	11.4	7.7	12.4	7.7
	14	6.3	5.6	7.7	6.4	8.6	6.8	9.6	7.3	10.8	7.8	11.4	7.7	12.4	7.7
	20	6.3	5.6	7.7	6.4	8.6	6.8	9.6	7.3	10.8	7.8	11.4	7.7	12.4	7.7
	23	6.3	5.6	7.7	6.4	8.6	6.8	9.6	7.3	10.8	7.8	11.4	7.7	12.4	7.7
	25	6.3	5.6	7.7	6.4	8.6	6.8	9.6	7.3	10.8	7.8	11.4	7.7	12.4	7.7
	30	6.3	5.6	7.7	6.4	8.6	6.8	9.6	7.3	10.8	7.8	11.4	7.7	12.4	7.7
	35	6.3	5.6	7.7	6.4	8.6	6.8	9.6	7.3	10.8	7.8	11.4	7.7	12.4	7.7
	40	6.3	5.6	7.7	6.4	8.6	6.8	9.6	7.3	10.8	7.8	11.4	7.7	12.4	7.7
	45	6.3	5.6	7.7	6.4	8.6	6.8	9.6	7.3	10.8	7.8	11.4	7.7	12.4	7.7
	50	6.3	5.6	7.7	6.4	8.6	6.8	9.6	7.3	10.8	7.8	11.4	7.7	12.4	7.7
	55	6.3	5.6	7.7	6.4	8.6	6.8	9.6	7.3	10.8	7.8	11.4	7.7	12.4	7.7
	60	6.3	5.6	7.7	6.4	8.6	6.8	9.6	7.3	10.8	7.8	11.4	7.7	12.3	7.7
	65	6.3	5.6	7.7	6.4	8.6	6.8	9.6	7.3	10.8	7.8	11.4	7.7	12.1	7.6
	70	6.3	5.6	7.7	6.4	8.6	6.8	9.6	7.3	10.8	7.8	11.4	7.7	11.9	7.4
	75	6.3	5.6	7.7	6.4	8.6	6.8	9.6	7.3	10.8	7.8	11.4	7.7	11.6	7.3
	80	6.3	5.6	7.7	6.4	8.6	6.8	9.6	7.3	10.8	7.8	11.1	7.7	11.3	7.2
85	6.3	5.6	7.7	6.4	8.6	6.8	9.6	7.3	10.6	7.7	10.8	7.4	11.0	6.9	
90	6.3	5.6	7.7	6.4	8.6	6.8	9.6	7.3	10.5	7.6	10.6	7.2	10.8	6.9	
95	6.3	5.6	7.7	6.4	8.6	6.8	9.6	7.3	10.3	7.6	10.5	7.2	10.6	6.8	
100	6.3	5.6	7.7	6.4	8.6	6.8	9.6	7.3	10.1	7.4	10.3	7.1	10.5	6.7	
105	6.3	5.6	7.3	6.1	8.2	6.5	9.2	6.9	9.6	6.9	9.9	6.9	10.2	6.6	
110	6.2	5.4	6.9	5.8	7.7	6.1	8.6	6.5	9.0	6.5	9.4	6.5	9.8	6.4	
115	6.0	5.2	6.6	5.5	7.2	5.7	8.1	6.2	8.5	6.2	8.9	6.2	9.4	6.1	
118	5.9	5.1	6.2	5.2	6.9	5.4	7.8	5.9	8.1	5.9	8.5	5.9	9.0	5.9	
122	5.7	4.9	5.9	4.9	6.5	5.1	7.4	5.6	7.7	5.6	8.1	5.6	8.7	5.6	

TC: Total Capacity (MBh); SHC: Sensible Heat Capacity (MBh).
 Cooling range with the Low Ambient Baffle Kit (sold separately) installed on the outdoor unit(s) is -9.9°F to +122°F, and is achieved only when all indoor units are operating in cooling mode. Does not impact heat recovery system synchronous operating range.
 The System Combination Ratio must be between 50–130%.

Rated capacity is certified under AHRI Standard 1230. Ratings are subject to change without notice.
 Current certified ratings are available at www.ahrirectory.org.
 For outdoor unit performance data, see the respective outdoor unit performance data manuals on <https://lghvac.com/commercial>.

Note:

Low ambient performance with LGRED° heat technology is included in Multi V 5 Air Source Units produced after February 2019.



Table 45: ARNU123SJS4 Cooling Capacity Table.

Model No. / Capacity Index	Outdoor Air Temp. (°F DB)	Indoor Air Temperature (°F DB / WB)													
		68 / 57		73 / 61		79 / 64		80 / 67		85 / 70		88 / 73		91 / 76	
		TC	SHC	TC	SHC	TC	SHC	TC	SHC	TC	SHC	TC	SHC	TC	SHC
ARNU123SJS4/12.3	-9.9	8.1	6.7	9.8	7.7	11.1	8.2	12.3	8.7	13.8	9.4	14.7	9.3	15.9	9.3
	-5	8.1	6.7	9.8	7.7	11.1	8.2	12.3	8.7	13.8	9.4	14.7	9.3	15.9	9.3
	0	8.1	6.7	9.8	7.7	11.1	8.2	12.3	8.7	13.8	9.4	14.7	9.3	15.9	9.3
	5	8.1	6.7	9.8	7.7	11.1	8.2	12.3	8.7	13.8	9.4	14.7	9.3	15.9	9.3
	10	8.1	6.7	9.8	7.7	11.1	8.2	12.3	8.7	13.8	9.4	14.7	9.3	15.9	9.3
	14	8.1	6.7	9.8	7.7	11.1	8.2	12.3	8.7	13.8	9.4	14.7	9.3	15.9	9.3
	20	8.1	6.7	9.8	7.7	11.1	8.2	12.3	8.7	13.8	9.4	14.7	9.3	15.9	9.3
	23	8.1	6.7	9.8	7.7	11.1	8.2	12.3	8.7	13.8	9.4	14.7	9.3	15.9	9.3
	25	8.1	6.7	9.8	7.7	11.1	8.2	12.3	8.7	13.8	9.4	14.7	9.3	15.9	9.3
	30	8.1	6.7	9.8	7.7	11.1	8.2	12.3	8.7	13.8	9.4	14.7	9.3	15.9	9.3
	35	8.1	6.7	9.8	7.7	11.1	8.2	12.3	8.7	13.8	9.4	14.7	9.3	15.9	9.3
	40	8.1	6.7	9.8	7.7	11.1	8.2	12.3	8.7	13.8	9.4	14.7	9.3	15.9	9.3
	45	8.1	6.7	9.8	7.7	11.1	8.2	12.3	8.7	13.8	9.4	14.7	9.3	15.9	9.3
	50	8.1	6.7	9.8	7.7	11.1	8.2	12.3	8.7	13.8	9.4	14.7	9.3	15.9	9.3
	55	8.1	6.7	9.8	7.7	11.1	8.2	12.3	8.7	13.8	9.4	14.7	9.3	15.9	9.3
	60	8.1	6.7	9.8	7.7	11.1	8.2	12.3	8.7	13.8	9.4	14.7	9.3	15.7	9.2
	65	8.1	6.7	9.8	7.7	11.1	8.2	12.3	8.7	13.8	9.4	14.7	9.3	15.5	9.1
	70	8.1	6.7	9.8	7.7	11.1	8.2	12.3	8.7	13.8	9.4	14.7	9.3	15.3	8.9
	75	8.1	6.7	9.8	7.7	11.1	8.2	12.3	8.7	13.8	9.4	14.7	9.3	14.9	8.7
	80	8.1	6.7	9.8	7.7	11.1	8.2	12.3	8.7	13.8	9.4	14.2	9.2	14.5	8.7
85	8.1	6.7	9.8	7.7	11.1	8.2	12.3	8.7	13.6	9.3	13.8	8.8	14.0	8.4	
90	8.1	6.7	9.8	7.7	11.1	8.2	12.3	8.7	13.4	9.1	13.5	8.7	13.8	8.3	
95	8.1	6.7	9.8	7.7	11.1	8.2	12.3	8.7	13.2	9.1	13.4	8.6	13.6	8.2	
100	8.1	6.7	9.8	7.7	11.1	8.2	12.3	8.7	12.9	8.9	13.2	8.5	13.4	8.1	
105	8.1	6.7	9.3	7.3	10.6	7.9	11.8	8.4	12.3	8.4	12.7	8.3	13.0	7.9	
110	7.9	6.5	8.9	6.9	9.8	7.3	11.1	7.9	11.6	7.9	12.0	7.9	12.6	7.7	
115	7.7	6.3	8.4	6.6	9.2	6.9	10.4	7.5	10.9	7.5	11.4	7.5	12.1	7.4	
118	7.5	6.1	8.0	6.2	8.8	6.5	10.0	7.1	10.4	7.1	10.9	7.1	11.6	7.1	
122	7.3	5.9	7.6	5.9	8.3	6.1	9.4	6.7	9.8	6.7	10.3	6.7	11.1	6.7	

Standard Wall-Mounted

TC: Total Capacity (MBh); SHC: Sensible Heat Capacity (MBh).
Cooling range with the Low Ambient Baffle Kit (sold separately) installed on the outdoor unit(s) is -9.9°F to +122°F, and is achieved only when all indoor units are operating in cooling mode. Does not impact heat recovery system synchronous operating range. The System Combination Ratio must be between 50–130%.

Rated capacity is certified under AHRI Standard 1230. Ratings are subject to change without notice.
Current certified ratings are available at www.ahrirectory.org.
For outdoor unit performance data, see the respective outdoor unit performance data manuals on <https://lghvac.com/commercial>.

Note:
Low ambient performance with LGRED° heat technology is included in Multi V 5 Air Source Units produced after February 2019.

STANDARD WALL-MOUNTED



Cooling Capacity Tables

ARNU153SJS4

Table 46: ARNU153SJS4 Cooling Capacity Table.

Model No. / Capacity Index	Outdoor Air Temp. (°F DB)	Indoor Air Temperature (°F DB / WB)													
		68 / 57		73 / 61		79 / 64		80 / 67		85 / 70		88 / 73		91 / 76	
		TC	SHC	TC	SHC	TC	SHC	TC	SHC	TC	SHC	TC	SHC	TC	SHC
ARNU153SJS4/ 15.4	-9.9	10.1	8.4	12.3	9.7	13.9	10.4	15.4	11.0	17.3	11.8	18.4	11.7	19.9	11.7
	-5	10.1	8.4	12.3	9.7	13.9	10.4	15.4	11.0	17.3	11.8	18.4	11.7	19.9	11.7
	0	10.1	8.4	12.3	9.7	13.9	10.4	15.4	11.0	17.3	11.8	18.4	11.7	19.9	11.7
	5	10.1	8.4	12.3	9.7	13.9	10.4	15.4	11.0	17.3	11.8	18.4	11.7	19.9	11.7
	10	10.1	8.4	12.3	9.7	13.9	10.4	15.4	11.0	17.3	11.8	18.4	11.7	19.9	11.7
	14	10.1	8.4	12.3	9.7	13.9	10.4	15.4	11.0	17.3	11.8	18.4	11.7	19.9	11.7
	20	10.1	8.4	12.3	9.7	13.9	10.4	15.4	11.0	17.3	11.8	18.4	11.7	19.9	11.7
	23	10.1	8.4	12.3	9.7	13.9	10.4	15.4	11.0	17.3	11.8	18.4	11.7	19.9	11.7
	25	10.1	8.4	12.3	9.7	13.9	10.4	15.4	11.0	17.3	11.8	18.4	11.7	19.9	11.7
	30	10.1	8.4	12.3	9.7	13.9	10.4	15.4	11.0	17.3	11.8	18.4	11.7	19.9	11.7
	35	10.1	8.4	12.3	9.7	13.9	10.4	15.4	11.0	17.3	11.8	18.4	11.7	19.9	11.7
	40	10.1	8.4	12.3	9.7	13.9	10.4	15.4	11.0	17.3	11.8	18.4	11.7	19.9	11.7
	45	10.1	8.4	12.3	9.7	13.9	10.4	15.4	11.0	17.3	11.8	18.4	11.7	19.9	11.7
	50	10.1	8.4	12.3	9.7	13.9	10.4	15.4	11.0	17.3	11.8	18.4	11.7	19.9	11.7
	55	10.1	8.4	12.3	9.7	13.9	10.4	15.4	11.0	17.3	11.8	18.4	11.7	19.9	11.7
	60	10.1	8.4	12.3	9.7	13.9	10.4	15.4	11.0	17.3	11.8	18.4	11.7	19.7	11.7
	65	10.1	8.4	12.3	9.7	13.9	10.4	15.4	11.0	17.3	11.8	18.4	11.7	19.4	11.5
	70	10.1	8.4	12.3	9.7	13.9	10.4	15.4	11.0	17.3	11.8	18.4	11.7	19.1	11.3
	75	10.1	8.4	12.3	9.7	13.9	10.4	15.4	11.0	17.3	11.8	18.4	11.7	18.6	11.0
	80	10.1	8.4	12.3	9.7	13.9	10.4	15.4	11.0	17.3	11.8	17.8	11.7	18.2	11.0
85	10.1	8.4	12.3	9.7	13.9	10.4	15.4	11.0	17.1	11.7	17.3	11.2	17.6	10.5	
90	10.1	8.4	12.3	9.7	13.9	10.4	15.4	11.0	16.8	11.5	16.9	11.0	17.3	10.4	
95	10.1	8.4	12.3	9.7	13.9	10.4	15.4	11.0	16.5	11.5	16.8	10.9	17.1	10.3	
100	10.1	8.4	12.3	9.7	13.9	10.4	15.4	11.0	16.2	11.3	16.5	10.8	16.8	10.2	
105	10.1	8.4	11.7	9.2	13.2	9.9	14.8	10.5	15.4	10.5	15.8	10.4	16.3	10.0	
110	9.9	8.2	11.1	8.7	12.3	9.2	13.9	9.9	14.5	9.9	15.1	9.9	15.7	9.7	
115	9.6	8.0	10.5	8.3	11.6	8.7	13.0	9.4	13.6	9.4	14.3	9.4	15.1	9.3	
118	9.4	7.7	10.0	7.9	11.0	8.2	12.5	9.0	13.0	9.0	13.7	9.0	14.5	8.9	
122	9.1	7.5	9.5	7.5	10.4	7.7	11.8	8.5	12.3	8.5	12.9	8.5	13.9	8.5	

TC: Total Capacity (MBh); SHC: Sensible Heat Capacity (MBh).
Cooling range with the Low Ambient Baffle Kit (sold separately) installed on the outdoor unit(s) is -9.9°F to +122°F, and is achieved only when all indoor units are operating in cooling mode. Does not impact heat recovery system synchronous operating range. The System Combination Ratio must be between 50-130%.

Rated capacity is certified under AHRI Standard 1230. Ratings are subject to change without notice.
Current certified ratings are available at www.ahridirectory.org.
For outdoor unit performance data, see the respective outdoor unit performance data manuals on <https://lghvac.com/commercial>.

Note:

Low ambient performance with LGRED° heat technology is included in Multi V 5 Air Source Units produced after February 2019.



Table 47: ARNU183SKS4 Cooling Capacity Table.

Model No. / Capacity Index	Outdoor Air Temp. (°F DB)	Indoor Air Temperature (°F DB / WB)													
		68 / 57		73 / 61		79 / 64		80 / 67		85 / 70		88 / 73		91 / 76	
		TC	SHC	TC	SHC	TC	SHC	TC	SHC	TC	SHC	TC	SHC	TC	SHC
ARNU183SKS4/ 19.1	-9.9	12.6	10.4	15.3	12.0	17.2	12.7	19.1	13.6	21.4	14.6	22.8	14.4	24.7	14.4
	-5	12.6	10.4	15.3	12.0	17.2	12.7	19.1	13.6	21.4	14.6	22.8	14.4	24.7	14.4
	0	12.6	10.4	15.3	12.0	17.2	12.7	19.1	13.6	21.4	14.6	22.8	14.4	24.7	14.4
	5	12.6	10.4	15.3	12.0	17.2	12.7	19.1	13.6	21.4	14.6	22.8	14.4	24.7	14.4
	10	12.6	10.4	15.3	12.0	17.2	12.7	19.1	13.6	21.4	14.6	22.8	14.4	24.7	14.4
	14	12.6	10.4	15.3	12.0	17.2	12.7	19.1	13.6	21.4	14.6	22.8	14.4	24.7	14.4
	20	12.6	10.4	15.3	12.0	17.2	12.7	19.1	13.6	21.4	14.6	22.8	14.4	24.7	14.4
	23	12.6	10.4	15.3	12.0	17.2	12.7	19.1	13.6	21.4	14.6	22.8	14.4	24.7	14.4
	25	12.6	10.4	15.3	12.0	17.2	12.7	19.1	13.6	21.4	14.6	22.8	14.4	24.7	14.4
	30	12.6	10.4	15.3	12.0	17.2	12.7	19.1	13.6	21.4	14.6	22.8	14.4	24.7	14.4
	35	12.6	10.4	15.3	12.0	17.2	12.7	19.1	13.6	21.4	14.6	22.8	14.4	24.7	14.4
	40	12.6	10.4	15.3	12.0	17.2	12.7	19.1	13.6	21.4	14.6	22.8	14.4	24.7	14.4
	45	12.6	10.4	15.3	12.0	17.2	12.7	19.1	13.6	21.4	14.6	22.8	14.4	24.7	14.4
	50	12.6	10.4	15.3	12.0	17.2	12.7	19.1	13.6	21.4	14.6	22.8	14.4	24.7	14.4
	55	12.6	10.4	15.3	12.0	17.2	12.7	19.1	13.6	21.4	14.6	22.8	14.4	24.7	14.4
	60	12.6	10.4	15.3	12.0	17.2	12.7	19.1	13.6	21.4	14.6	22.8	14.4	24.4	14.3
	65	12.6	10.4	15.3	12.0	17.2	12.7	19.1	13.6	21.4	14.6	22.8	14.4	24.0	14.1
	70	12.6	10.4	15.3	12.0	17.2	12.7	19.1	13.6	21.4	14.6	22.8	14.4	23.7	13.9
	75	12.6	10.4	15.3	12.0	17.2	12.7	19.1	13.6	21.4	14.6	22.8	14.4	23.1	13.6
	80	12.6	10.4	15.3	12.0	17.2	12.7	19.1	13.6	21.4	14.6	22.1	14.3	22.5	13.5
85	12.6	10.4	15.3	12.0	17.2	12.7	19.1	13.6	21.2	14.4	21.4	13.7	21.8	13.0	
90	12.6	10.4	15.3	12.0	17.2	12.7	19.1	13.6	20.9	14.2	21.0	13.5	21.4	12.8	
95	12.6	10.4	15.3	12.0	17.2	12.7	19.1	13.6	20.5	14.1	20.9	13.4	21.2	12.6	
100	12.6	10.4	15.3	12.0	17.2	12.7	19.1	13.6	20.1	13.9	20.5	13.3	20.9	12.6	
105	12.6	10.4	14.5	11.4	16.4	12.2	18.3	13.0	19.0	13.0	19.7	12.8	20.2	12.3	
110	12.3	10.1	13.8	10.7	15.3	11.4	17.2	12.2	18.0	12.2	18.7	12.2	19.5	11.9	
115	12.0	9.8	13.1	10.2	14.4	10.7	16.2	11.6	16.9	11.6	17.8	11.6	18.7	11.4	
118	11.7	9.5	12.4	9.7	13.6	10.0	15.5	11.0	16.1	11.0	17.0	11.0	18.0	10.9	
122	11.3	9.2	11.8	9.2	12.9	9.4	14.7	10.4	15.3	10.4	16.0	10.4	17.2	10.4	

Standard Wall-Mounted

TC: Total Capacity (MBh); SHC: Sensible Heat Capacity (MBh).
Cooling range with the Low Ambient Baffle Kit (sold separately) installed on the outdoor unit(s) is -9.9°F to +122°F, and is achieved only when all indoor units are operating in cooling mode. Does not impact heat recovery system synchronous operating range.
The System Combination Ratio must be between 50–130%.

Rated capacity is certified under AHRI Standard 1230. Ratings are subject to change without notice.
Current certified ratings are available at www.ahridirectory.org.
For outdoor unit performance data, see the respective outdoor unit performance data manuals on <https://lghvac.com/commercial>.

Note:

Low ambient performance with LGRED° heat technology is included in Multi V 5 Air Source Units produced after February 2019.

STANDARD WALL-MOUNTED



Cooling Capacity Tables

ARNU243SKS4

Table 48: ARNU243SKS4 Cooling Capacity Table.

Model No. / Capacity Index	Outdoor Air Temp. (°F DB)	Indoor Air Temperature (°F DB / WB)													
		68 / 57		73 / 61		79 / 64		80 / 67		85 / 70		88 / 73		91 / 76	
		TC	SHC	TC	SHC	TC	SHC	TC	SHC	TC	SHC	TC	SHC	TC	SHC
ARNU243SKS4/ 24.2	-9.9	15.9	13.0	19.4	15.0	21.8	15.9	24.2	17.0	27.1	18.2	28.8	18.0	31.3	18.0
	-5	15.9	13.0	19.4	15.0	21.8	15.9	24.2	17.0	27.1	18.2	28.8	18.0	31.3	18.0
	0	15.9	13.0	19.4	15.0	21.8	15.9	24.2	17.0	27.1	18.2	28.8	18.0	31.3	18.0
	5	15.9	13.0	19.4	15.0	21.8	15.9	24.2	17.0	27.1	18.2	28.8	18.0	31.3	18.0
	10	15.9	13.0	19.4	15.0	21.8	15.9	24.2	17.0	27.1	18.2	28.8	18.0	31.3	18.0
	14	15.9	13.0	19.4	15.0	21.8	15.9	24.2	17.0	27.1	18.2	28.8	18.0	31.3	18.0
	20	15.9	13.0	19.4	15.0	21.8	15.9	24.2	17.0	27.1	18.2	28.8	18.0	31.3	18.0
	23	15.9	13.0	19.4	15.0	21.8	15.9	24.2	17.0	27.1	18.2	28.8	18.0	31.3	18.0
	25	15.9	13.0	19.4	15.0	21.8	15.9	24.2	17.0	27.1	18.2	28.8	18.0	31.3	18.0
	30	15.9	13.0	19.4	15.0	21.8	15.9	24.2	17.0	27.1	18.2	28.8	18.0	31.3	18.0
	35	15.9	13.0	19.4	15.0	21.8	15.9	24.2	17.0	27.1	18.2	28.8	18.0	31.3	18.0
	40	15.9	13.0	19.4	15.0	21.8	15.9	24.2	17.0	27.1	18.2	28.8	18.0	31.3	18.0
	45	15.9	13.0	19.4	15.0	21.8	15.9	24.2	17.0	27.1	18.2	28.8	18.0	31.3	18.0
	50	15.9	13.0	19.4	15.0	21.8	15.9	24.2	17.0	27.1	18.2	28.8	18.0	31.3	18.0
	55	15.9	13.0	19.4	15.0	21.8	15.9	24.2	17.0	27.1	18.2	28.8	18.0	31.3	18.0
	60	15.9	13.0	19.4	15.0	21.8	15.9	24.2	17.0	27.1	18.2	28.8	18.0	31.0	17.9
	65	15.9	13.0	19.4	15.0	21.8	15.9	24.2	17.0	27.1	18.2	28.8	18.0	30.5	17.7
	70	15.9	13.0	19.4	15.0	21.8	15.9	24.2	17.0	27.1	18.2	28.8	18.0	30.0	17.4
	75	15.9	13.0	19.4	15.0	21.8	15.9	24.2	17.0	27.1	18.2	28.8	18.0	29.2	17.0
	80	15.9	13.0	19.4	15.0	21.8	15.9	24.2	17.0	27.1	18.2	28.0	17.9	28.5	16.9
	85	15.9	13.0	19.4	15.0	21.8	15.9	24.2	17.0	26.8	18.0	27.1	17.2	27.6	16.2
90	15.9	13.0	19.4	15.0	21.8	15.9	24.2	17.0	26.4	17.8	26.6	16.9	27.1	16.0	
95	15.9	13.0	19.4	15.0	21.8	15.9	24.2	17.0	25.9	17.7	26.4	16.8	26.8	15.8	
100	15.9	13.0	19.4	15.0	21.8	15.9	24.2	17.0	25.4	17.4	25.9	16.6	26.4	15.7	
105	15.9	13.0	18.4	14.2	20.8	15.3	23.2	16.2	24.1	16.2	24.9	16.0	25.6	15.4	
110	15.5	12.6	17.4	13.5	19.4	14.2	21.8	15.3	22.8	15.3	23.7	15.3	24.7	14.9	
115	15.1	12.2	16.6	12.8	18.2	13.4	20.5	14.5	21.4	14.5	22.5	14.5	23.7	14.3	
118	14.8	11.9	15.7	12.1	17.3	12.6	19.7	13.8	20.4	13.8	21.5	13.8	22.8	13.7	
122	14.4	11.5	15.0	11.5	16.3	11.8	18.6	13.1	19.4	13.1	20.3	13.1	21.9	13.1	

TC: Total Capacity (MBh); SHC: Sensible Heat Capacity (MBh).
 Cooling range with the Low Ambient Baffle Kit (sold separately) installed on the outdoor unit(s) is -9.9°F to +122°F, and is achieved only when all indoor units are operating in cooling mode. Does not impact heat recovery system synchronous operating range.
 The System Combination Ratio must be between 50–130%.

Rated capacity is certified under AHRI Standard 1230. Ratings are subject to change without notice.
 Current certified ratings are available at www.ahridirectory.org.
 For outdoor unit performance data, see the respective outdoor unit performance data manuals on <https://lghvac.com/commercial>.

Note:

Low ambient performance with LGRED° heat technology is included in Multi V 5 Air Source Units produced after February 2019.



Table 49: ARNU303SVA4 Cooling Capacity Table.

Model No. / Capacity Index	Outdoor Air Temp. (°F DB)	Indoor Air Temperature (°F DB / WB)													
		68 / 57		73 / 61		79 / 64		80 / 67		85 / 70		88 / 73		91 / 76	
		TC	SHC	TC	SHC	TC	SHC	TC	SHC	TC	SHC	TC	SHC	TC	SHC
ARNU303SVA4/30.0	-9.9	19.8	16.5	24.0	19.1	27.0	20.3	30.0	21.6	33.6	23.2	35.8	22.9	38.8	22.9
	-5	19.8	16.5	24.0	19.1	27.0	20.3	30.0	21.6	33.6	23.2	35.8	22.9	38.8	22.9
	0	19.8	16.5	24.0	19.1	27.0	20.3	30.0	21.6	33.6	23.2	35.8	22.9	38.8	22.9
	5	19.8	16.5	24.0	19.1	27.0	20.3	30.0	21.6	33.6	23.2	35.8	22.9	38.8	22.9
	10	19.8	16.5	24.0	19.1	27.0	20.3	30.0	21.6	33.6	23.2	35.8	22.9	38.8	22.9
	14	19.8	16.5	24.0	19.1	27.0	20.3	30.0	21.6	33.6	23.2	35.8	22.9	38.8	22.9
	20	19.8	16.5	24.0	19.1	27.0	20.3	30.0	21.6	33.6	23.2	35.8	22.9	38.8	22.9
	23	19.8	16.5	24.0	19.1	27.0	20.3	30.0	21.6	33.6	23.2	35.8	22.9	38.8	22.9
	25	19.8	16.5	24.0	19.1	27.0	20.3	30.0	21.6	33.6	23.2	35.8	22.9	38.8	22.9
	30	19.8	16.5	24.0	19.1	27.0	20.3	30.0	21.6	33.6	23.2	35.8	22.9	38.8	22.9
	35	19.8	16.5	24.0	19.1	27.0	20.3	30.0	21.6	33.6	23.2	35.8	22.9	38.8	22.9
	40	19.8	16.5	24.0	19.1	27.0	20.3	30.0	21.6	33.6	23.2	35.8	22.9	38.8	22.9
	45	19.8	16.5	24.0	19.1	27.0	20.3	30.0	21.6	33.6	23.2	35.8	22.9	38.8	22.9
	50	19.8	16.5	24.0	19.1	27.0	20.3	30.0	21.6	33.6	23.2	35.8	22.9	38.8	22.9
	55	19.8	16.5	24.0	19.1	27.0	20.3	30.0	21.6	33.6	23.2	35.8	22.9	38.8	22.9
	60	19.8	16.5	24.0	19.1	27.0	20.3	30.0	21.6	33.6	23.2	35.8	22.9	38.4	22.8
	65	19.8	16.5	24.0	19.1	27.0	20.3	30.0	21.6	33.6	23.2	35.8	22.9	37.8	22.4
	70	19.8	16.5	24.0	19.1	27.0	20.3	30.0	21.6	33.6	23.2	35.8	22.9	37.3	22.1
	75	19.8	16.5	24.0	19.1	27.0	20.3	30.0	21.6	33.6	23.2	35.8	22.9	36.3	21.6
	80	19.8	16.5	24.0	19.1	27.0	20.3	30.0	21.6	33.6	23.2	34.8	22.8	35.4	21.5
85	19.8	16.5	24.0	19.1	27.0	20.3	30.0	21.6	33.3	22.9	33.6	21.8	34.3	20.6	
90	19.8	16.5	24.0	19.1	27.0	20.3	30.0	21.6	32.8	22.6	33.0	21.5	33.6	20.4	
95	19.8	16.5	24.0	19.1	27.0	20.3	30.0	21.6	32.1	22.4	32.8	21.4	33.3	20.1	
100	19.8	16.5	24.0	19.1	27.0	20.3	30.0	21.6	31.5	22.1	32.1	21.1	32.8	20.0	
105	19.8	16.5	22.8	18.1	25.8	19.4	28.8	20.6	29.9	20.6	30.9	20.4	31.8	19.5	
110	19.3	16.0	21.6	17.1	24.0	18.1	27.0	19.4	28.3	19.4	29.4	19.4	30.6	18.9	
115	18.8	15.6	20.6	16.2	22.6	17.0	25.4	18.4	26.6	18.4	27.9	18.4	29.4	18.2	
118	18.3	15.1	19.5	15.4	21.4	16.0	24.4	17.5	25.4	17.5	26.6	17.5	28.2	17.4	
122	17.8	14.6	18.5	14.6	20.3	15.0	23.0	16.6	24.0	16.6	25.2	16.6	27.1	16.6	

Standard Wall-Mounted

TC: Total Capacity (MBh); SHC: Sensible Heat Capacity (MBh).
 Cooling range with the Low Ambient Baffle Kit (sold separately) installed on the outdoor unit(s) is -9.9°F to +122°F, and is achieved only when all indoor units are operating in cooling mode. Does not impact heat recovery system synchronous operating range.
 The System Combination Ratio must be between 50–130%.

Rated capacity is certified under AHRI Standard 1230. Ratings are subject to change without notice.
 Current certified ratings are available at www.ahridirectory.org.
 For outdoor unit performance data, see the respective outdoor unit performance data manuals on <https://lghvac.com/commercial>.

Note:
 Low ambient performance with LGRED° heat technology is included in Multi V 5 Air Source Units produced after February 2019.

STANDARD WALL-MOUNTED



Cooling Capacity Tables

ARNU363SVA4

Table 50: ARNU363SVA4 Cooling Capacity Table.

Model No. / Capacity Index	Outdoor Air Temp. (°F DB)	Indoor Air Temperature (°F DB / WB)													
		68 / 57		73 / 61		79 / 64		80 / 67		85 / 70		88 / 73		91 / 76	
		TC	SHC	TC	SHC	TC	SHC	TC	SHC	TC	SHC	TC	SHC	TC	SHC
ARNU363SVA4/ 36.2	-9.9	23.4	19.8	28.4	22.9	32.0	24.3	35.5	25.9	39.8	27.8	42.3	27.5	45.9	27.5
	-5	23.4	19.8	28.4	22.9	32.0	24.3	35.5	25.9	39.8	27.8	42.3	27.5	45.9	27.5
	0	23.4	19.8	28.4	22.9	32.0	24.3	35.5	25.9	39.8	27.8	42.3	27.5	45.9	27.5
	5	23.4	19.8	28.4	22.9	32.0	24.3	35.5	25.9	39.8	27.8	42.3	27.5	45.9	27.5
	10	23.4	19.8	28.4	22.9	32.0	24.3	35.5	25.9	39.8	27.8	42.3	27.5	45.9	27.5
	14	23.4	19.8	28.4	22.9	32.0	24.3	35.5	25.9	39.8	27.8	42.3	27.5	45.9	27.5
	20	23.4	19.8	28.4	22.9	32.0	24.3	35.5	25.9	39.8	27.8	42.3	27.5	45.9	27.5
	23	23.4	19.8	28.4	22.9	32.0	24.3	35.5	25.9	39.8	27.8	42.3	27.5	45.9	27.5
	25	23.4	19.8	28.4	22.9	32.0	24.3	35.5	25.9	39.8	27.8	42.3	27.5	45.9	27.5
	30	23.4	19.8	28.4	22.9	32.0	24.3	35.5	25.9	39.8	27.8	42.3	27.5	45.9	27.5
	35	23.4	19.8	28.4	22.9	32.0	24.3	35.5	25.9	39.8	27.8	42.3	27.5	45.9	27.5
	40	23.4	19.8	28.4	22.9	32.0	24.3	35.5	25.9	39.8	27.8	42.3	27.5	45.9	27.5
	45	23.4	19.8	28.4	22.9	32.0	24.3	35.5	25.9	39.8	27.8	42.3	27.5	45.9	27.5
	50	23.4	19.8	28.4	22.9	32.0	24.3	35.5	25.9	39.8	27.8	42.3	27.5	45.9	27.5
	55	23.4	19.8	28.4	22.9	32.0	24.3	35.5	25.9	39.8	27.8	42.3	27.5	45.9	27.5
	60	23.4	19.8	28.4	22.9	32.0	24.3	35.5	25.9	39.8	27.8	42.3	27.5	45.4	27.4
	65	23.4	19.8	28.4	22.9	32.0	24.3	35.5	25.9	39.8	27.8	42.3	27.5	44.7	26.9
	70	23.4	19.8	28.4	22.9	32.0	24.3	35.5	25.9	39.8	27.8	42.3	27.5	44.1	26.5
	75	23.4	19.8	28.4	22.9	32.0	24.3	35.5	25.9	39.8	27.8	42.3	27.5	42.9	25.9
	80	23.4	19.8	28.4	22.9	32.0	24.3	35.5	25.9	39.8	27.8	41.1	27.4	41.9	25.8
85	23.4	19.8	28.4	22.9	32.0	24.3	35.5	25.9	39.3	27.5	39.8	26.2	40.5	24.8	
90	23.4	19.8	28.4	22.9	32.0	24.3	35.5	25.9	38.8	27.1	39.1	25.8	39.8	24.5	
95	23.4	19.8	28.4	22.9	32.0	24.3	35.5	25.9	38.0	26.9	38.8	25.6	39.3	24.2	
100	23.4	19.8	28.4	22.9	32.0	24.3	35.5	25.9	37.3	26.5	38.0	25.3	38.8	24.0	
105	23.4	19.8	26.9	21.7	30.5	23.3	34.0	24.8	35.4	24.8	36.5	24.5	37.6	23.4	
110	22.8	19.2	25.6	20.5	28.4	21.7	32.0	23.3	33.4	23.3	34.8	23.3	36.2	22.7	
115	22.2	18.7	24.3	19.5	26.7	20.4	30.0	22.1	31.4	22.1	33.0	22.1	34.8	21.8	
118	21.7	18.1	23.1	18.5	25.3	19.2	28.8	21.0	30.0	21.0	31.5	21.0	33.4	20.9	
122	21.1	17.5	21.9	17.6	24.0	18.0	27.3	20.0	28.4	20.0	29.8	20.0	32.1	20.0	

TC: Total Capacity (MBh); SHC: Sensible Heat Capacity (MBh).
 Cooling range with the Low Ambient Baffle Kit (sold separately) installed on the outdoor unit(s) is -9.9°F to +122°F, and is achieved only when all indoor units are operating in cooling mode. Does not impact heat recovery system synchronous operating range.
 The System Combination Ratio must be between 50–130%.

Rated capacity is certified under AHRI Standard 1230. Ratings are subject to change without notice.
 Current certified ratings are available at www.ahrirectory.org.
 For outdoor unit performance data, see the respective outdoor unit performance data manuals on <https://lghvac.com/commercial>.

Note:

Low ambient performance with LGRED° heat technology is included in Multi V 5 Air Source Units produced after February 2019.



Table 51: ARNU053SJS4 Heating Capacity Table.

Model No. / Capacity Index	Outdoor Air Temp.		Indoor Air Temperature (°F DB)							
			59	61	64	67	70	73	76	80
	°F DB	°F WB	TC	TC	TC	TC	TC	TC	TC	TC
MBh			MBh	MBh	MBh	MBh	MBh	MBh	MBh	
ARNU053SJS4/5.5	-21.6	-22.0	3.1	3.1	3.1	3.1	3.1	3.1	3.1	3.1
	-17.1	-17.5	3.5	3.5	3.5	3.5	3.4	3.4	3.4	3.4
	-12.6	-13	3.8	3.8	3.8	3.8	3.8	3.8	3.8	3.8
	-7	-7.6	4.0	4.0	4.0	4.0	3.9	3.9	3.9	3.9
	-4	-4.4	4.1	4.1	4.1	4.1	4.0	4.0	4.0	4.0
	0	-0.4	4.2	4.2	4.2	4.2	4.2	4.2	4.2	4.2
	5	4.5	4.8	4.7	4.6	4.6	4.6	4.6	4.6	4.6
	10	9	4.9	4.9	4.9	4.9	4.9	4.9	4.9	4.9
	15	14	5.3	5.3	5.3	5.3	5.3	5.3	5.2	5.1
	20	19	5.6	5.6	5.6	5.6	5.4	5.4	5.3	5.3
	25	23	5.8	5.8	5.8	5.8	5.8	5.7	5.6	5.3
	30	28	5.9	5.9	5.9	5.9	5.9	5.8	5.6	5.3
	35	32	6.1	6.1	6.1	6.1	6.0	5.9	5.6	5.3
	40	36	6.3	6.3	6.3	6.3	6.1	5.9	5.6	5.3
	45	41	6.6	6.6	6.6	6.4	6.1	5.9	5.6	5.3
	47	43	6.8	6.8	6.7	6.4	6.1	5.9	5.6	5.3
50	46	7.3	7.0	6.7	6.4	6.1	5.9	5.6	5.3	
55	51	7.5	7.1	6.7	6.4	6.1	5.9	5.6	5.3	
60	56	7.5	7.1	6.7	6.4	6.1	5.9	5.6	5.3	

TC: Total Capacity (MBh).
 The System Combination Ratio must be between 50–130%.
 Rated capacity is certified under AHRI Standard 1230. Ratings are subject to change without notice.

Current certified ratings are available at www.ahrirectory.org.
 For outdoor unit performance data, see the respective outdoor unit performance data manuals on <https://lghvac.com/commercial>.

Note:

Low ambient performance with LGRED° heat technology is included in Multi V 5 Air Source Units produced after February 2019.

Standard Wall-Mounted

STANDARD WALL-MOUNTED



Heating Capacity Tables

ARNU073SJS4

Table 52: ARNU073SJS4 Heating Capacity Table.

Model No. / Capacity Index	Outdoor Air Temp.		Indoor Air Temperature (°F DB)							
			59	61	64	67	70	73	76	80
	°F DB	°F WB	TC	TC	TC	TC	TC	TC	TC	TC
ARNU073SJS4/ 7.5	-21.6	-22.0	4.3	4.3	4.3	4.3	4.3	4.3	4.3	4.3
	-17.1	-17.5	4.8	4.8	4.8	4.8	4.8	4.8	4.8	4.8
	-12.6	-13	5.4	5.4	5.4	5.4	5.3	5.3	5.3	5.3
	-7	-7.6	5.5	5.5	5.5	5.5	5.4	5.4	5.4	5.4
	-4	-4.4	5.7	5.7	5.7	5.7	5.6	5.6	5.6	5.6
	0	-0.4	5.9	5.9	5.9	5.9	5.9	5.8	5.8	5.8
	5	4.5	6.6	6.6	6.5	6.5	6.5	6.5	6.5	6.5
	10	9	6.9	6.9	6.9	6.8	6.8	6.8	6.8	6.8
	15	14	7.3	7.3	7.3	7.3	7.3	7.3	7.2	7.1
	20	19	7.7	7.7	7.7	7.7	7.6	7.6	7.4	7.4
	25	23	8.1	8.1	8.1	8.1	8.1	7.9	7.8	7.4
	30	28	8.3	8.3	8.3	8.3	8.3	8.1	7.8	7.4
	35	32	8.5	8.5	8.5	8.5	8.4	8.3	7.8	7.4
	40	36	8.8	8.8	8.8	8.8	8.5	8.3	7.8	7.4
	45	41	9.2	9.2	9.2	8.9	8.5	8.3	7.8	7.4
	47	43	9.5	9.4	9.4	8.9	8.5	8.3	7.8	7.4
50	46	10.2	9.8	9.4	8.9	8.5	8.3	7.8	7.4	
55	51	10.4	9.9	9.4	8.9	8.5	8.3	7.8	7.4	
60	56	10.4	9.9	9.4	8.9	8.5	8.3	7.8	7.4	

TC: Total Capacity (MBh).

The System Combination Ratio must be between 50–130%.

Rated capacity is certified under AHRI Standard 1230. Ratings are subject to change without notice.

Current certified ratings are available at www.ahridirectory.org.

For outdoor unit performance data, see the respective outdoor unit performance data manuals on <https://ghvac.com/commercial>.

Note:

Low ambient performance with LGRED° heat technology is included in Multi V 5 Air Source Units produced after February 2019.

Table 53: ARNU093SJS4 Heating Capacity Table.

Model No. / Capacity Index	Outdoor Air Temp.		Indoor Air Temperature (°F DB)							
			59	61	64	67	70	73	76	80
	°F DB	°F WB	TC	TC	TC	TC	TC	TC	TC	TC
MBh			MBh	MBh	MBh	MBh	MBh	MBh	MBh	MBh
ARNU093SJS4/ 9.6	-21.6	-22.0	5.5	5.5	5.5	5.5	5.5	5.5	5.5	5.5
	-17.1	-17.5	6.2	6.2	6.2	6.2	6.1	6.1	6.1	6.1
	-12.6	-13	6.9	6.9	6.9	6.9	6.8	6.8	6.8	6.8
	-7	-7.6	7.1	7.1	7.1	7.1	7.0	7.0	7.0	7.0
	-4	-4.4	7.3	7.3	7.3	7.3	7.2	7.2	7.2	7.2
	0	-0.4	7.5	7.5	7.5	7.5	7.5	7.4	7.4	7.4
	5	4.5	8.5	8.4	8.3	8.3	8.3	8.3	8.3	8.3
	10	9	8.8	8.8	8.8	8.7	8.7	8.7	8.7	8.7
	15	14	9.4	9.4	9.4	9.4	9.4	9.4	9.3	9.2
	20	19	9.9	9.9	9.9	9.9	9.7	9.7	9.5	9.4
	25	23	10.4	10.4	10.4	10.4	10.4	10.1	10.0	9.5
	30	28	10.6	10.6	10.6	10.6	10.6	10.4	10.0	9.5
	35	32	10.9	10.9	10.9	10.9	10.8	10.6	10.0	9.5
	40	36	11.3	11.3	11.3	11.3	10.9	10.6	10.0	9.5
	45	41	11.8	11.8	11.8	11.5	10.9	10.6	10.0	9.5
	47	43	12.2	12.1	12.0	11.5	10.9	10.6	10.0	9.5
50	46	13.1	12.5	12.0	11.5	10.9	10.6	10.0	9.5	
55	51	13.4	12.6	12.0	11.5	10.9	10.6	10.0	9.5	
60	56	13.4	12.6	12.0	11.5	10.9	10.6	10.0	9.5	

TC: Total Capacity (MBh).

The System Combination Ratio must be between 50–130%.

Rated capacity is certified under AHRI Standard 1230. Ratings are subject to change without notice.

Current certified ratings are available at www.ahridirectory.org.

For outdoor unit performance data, see the respective outdoor unit performance data manuals on <https://ghvac.com/commercial>.

Note:

Low ambient performance with LGRED° heat technology is included in Multi V 5 Air Source Units produced after February 2019.

STANDARD WALL-MOUNTED



Heating Capacity Tables

ARNU123SJS4

Table 54: ARNU123SJS4 Heating Capacity Table.

Model No. / Capacity Index	Outdoor Air Temp.		Indoor Air Temperature (°F DB)							
			59	61	64	67	70	73	76	80
	°F DB	°F WB	TC	TC	TC	TC	TC	TC	TC	TC
ARNU123SJS4/ 12.3	-21.6	-22.0	6.9	6.9	6.9	6.9	6.8	6.8	6.8	6.8
	-17.1	-17.5	7.7	7.7	7.7	7.7	7.6	7.6	7.6	7.6
	-12.6	-13	8.6	8.6	8.6	8.6	8.5	8.5	8.5	8.5
	-7	-7.6	8.8	8.8	8.8	8.8	8.7	8.7	8.7	8.7
	-4	-4.4	9.1	9.1	9.1	9.1	9.0	9.0	9.0	9.0
	0	-0.4	9.4	9.4	9.4	9.4	9.4	9.3	9.3	9.3
	5	4.5	10.6	10.5	10.3	10.3	10.3	10.3	10.3	10.3
	10	9	11.0	11.0	11.0	10.9	10.9	10.9	10.9	10.9
	15	14	11.7	11.7	11.7	11.7	11.7	11.7	11.6	11.4
	20	19	12.4	12.4	12.4	12.4	12.1	12.1	11.9	11.8
	25	23	12.9	12.9	12.9	12.9	12.9	12.7	12.5	11.9
	30	28	13.2	13.2	13.2	13.2	13.2	12.9	12.5	11.9
	35	32	13.6	13.6	13.6	13.6	13.5	13.2	12.5	11.9
	40	36	14.1	14.1	14.1	14.1	13.6	13.2	12.5	11.9
	45	41	14.7	14.7	14.7	14.3	13.6	13.2	12.5	11.9
	47	43	15.2	15.1	15.0	14.3	13.6	13.2	12.5	11.9
50	46	16.3	15.6	15.0	14.3	13.6	13.2	12.5	11.9	
55	51	16.7	15.8	15.0	14.3	13.6	13.2	12.5	11.9	
60	56	16.7	15.8	15.0	14.3	13.6	13.2	12.5	11.9	

TC: Total Capacity (MBh).

The System Combination Ratio must be between 50–130%.

Rated capacity is certified under AHRI Standard 1230. Ratings are subject to change without notice.

Current certified ratings are available at www.ahrirectory.org.

For outdoor unit performance data, see the respective outdoor unit performance data manuals on <https://ghvac.com/commercial>.

Note:

Low ambient performance with LGRED° heat technology is included in Multi V 5 Air Source Units produced after February 2019.



Table 55: ARNU153SJS4 Heating Capacity Table.

Model No. / Capacity Index	Outdoor Air Temp.		Indoor Air Temperature (°F DB)							
			59	61	64	67	70	73	76	80
	°F DB	°F WB	TC	TC	TC	TC	TC	TC	TC	TC
ARNU153SJS4/ 15.4	-21.6	-22.0	8.7	8.7	8.7	8.7	8.6	8.6	8.6	8.6
	-17.1	-17.5	9.7	9.7	9.7	9.7	9.6	9.6	9.6	9.6
	-12.6	-13	10.8	10.8	10.8	10.8	10.6	10.6	10.6	10.6
	-7	-7.6	11.1	11.1	11.1	11.1	10.9	10.9	10.9	10.9
	-4	-4.4	11.5	11.5	11.5	11.5	11.3	11.3	11.3	11.3
	0	-0.4	11.8	11.8	11.8	11.8	11.8	11.6	11.6	11.6
	5	4.5	13.3	13.2	13.0	13.0	13.0	13.0	13.0	13.0
	10	9	13.9	13.9	13.9	13.7	13.7	13.7	13.7	13.7
	15	14	14.7	14.7	14.7	14.7	14.7	14.7	14.5	14.4
	20	19	15.6	15.6	15.6	15.6	15.2	15.2	15.0	14.8
	25	23	16.3	16.3	16.3	16.3	16.3	15.9	15.7	15.0
	30	28	16.6	16.6	16.6	16.6	16.6	16.3	15.7	15.0
	35	32	17.1	17.1	17.1	17.1	16.9	16.6	15.7	15.0
	40	36	17.8	17.8	17.8	17.8	17.1	16.6	15.7	15.0
	45	41	18.5	18.5	18.5	18.0	17.1	16.6	15.7	15.0
	47	43	19.2	19.0	18.8	18.0	17.1	16.6	15.7	15.0
50	46	20.5	19.7	18.8	18.0	17.1	16.6	15.7	15.0	
55	51	21.0	19.8	18.8	18.0	17.1	16.6	15.7	15.0	
60	56	21.0	19.8	18.8	18.0	17.1	16.6	15.7	15.0	

TC: Total Capacity (MBh).
 The System Combination Ratio must be between 50–130%.
 Rated capacity is certified under AHRI Standard 1230. Ratings are subject to change without notice.

Current certified ratings are available at www.ahridirectory.org.
 For outdoor unit performance data, see the respective outdoor unit performance data manuals on <https://lghvac.com/commercial>.

Note:

Low ambient performance with LGRED° heat technology is included in Multi V 5 Air Source Units produced after February 2019.

STANDARD WALL-MOUNTED



Heating Capacity Tables

ARNU183SKS4

Table 56: ARNU183SKS4 Heating Capacity Table.

Model No. / Capacity Index	Outdoor Air Temp.		Indoor Air Temperature (°F DB)							
			59	61	64	67	70	73	76	80
	°F DB	°F WB	TC	TC	TC	TC	TC	TC	TC	TC
			MBh	MBh	MBh	MBh	MBh	MBh	MBh	MBh
ARNU183SKS4/ 19.1	-21.6	-22.0	10.9	10.9	10.9	10.9	10.8	10.8	10.8	10.8
	-17.1	-17.5	12.2	12.2	12.2	12.2	12.1	12.1	12.1	12.1
	-12.6	-13	13.6	13.6	13.6	13.6	13.4	13.4	13.4	13.4
	-7	-7.6	14.0	14.0	14.0	14.0	13.8	13.8	13.8	13.8
	-4	-4.4	14.4	14.4	14.4	14.4	14.2	14.2	14.2	14.2
	0	-0.4	14.8	14.8	14.8	14.8	14.8	14.6	14.6	14.6
	5	4.5	16.8	16.6	16.3	16.3	16.3	16.3	16.3	16.3
	10	9	17.4	17.4	17.4	17.2	17.2	17.2	17.2	17.2
	15	14	18.5	18.5	18.5	18.5	18.5	18.5	18.3	18.1
	20	19	19.6	19.6	19.6	19.6	19.1	19.1	18.8	18.6
	25	23	20.4	20.4	20.4	20.4	20.4	20.0	19.8	18.8
	30	28	20.9	20.9	20.9	20.9	20.9	20.4	19.8	18.8
	35	32	21.5	21.5	21.5	21.5	21.3	20.9	19.8	18.8
	40	36	22.4	22.4	22.4	22.4	21.5	20.9	19.8	18.8
	45	41	23.2	23.2	23.2	22.6	21.5	20.9	19.8	18.8
	47	43	24.1	23.9	23.7	22.6	21.5	20.9	19.8	18.8
50	46	25.8	24.7	23.7	22.6	21.5	20.9	19.8	18.8	
55	51	26.3	24.9	23.7	22.6	21.5	20.9	19.8	18.8	
60	56	26.3	24.9	23.7	22.6	21.5	20.9	19.8	18.8	

TC: Total Capacity (MBh).

The System Combination Ratio must be between 50–130%.

Rated capacity is certified under AHRI Standard 1230. Ratings are subject to change without notice.

Current certified ratings are available at www.ahridirectory.org.

For outdoor unit performance data, see the respective outdoor unit performance data manuals on <https://lghvac.com/commercial>.

Note:

Low ambient performance with LGRED° heat technology is included in Multi V 5 Air Source Units produced after February 2019.

Table 57: ARNU243SKS4 Heating Capacity Table.

Model No. / Capacity Index	Outdoor Air Temp.		Indoor Air Temperature (°F DB)							
			59	61	64	67	70	73	76	80
	°F DB	°F WB	TC	TC	TC	TC	TC	TC	TC	TC
MBh			MBh	MBh	MBh	MBh	MBh	MBh	MBh	MBh
ARNU243SKS4/ 24.2	-21.6	-22.0	13.0	13.0	13.0	13.0	12.8	12.8	12.8	12.8
	-17.1	-17.5	14.6	14.6	14.6	14.6	14.4	14.4	14.4	14.4
	-12.6	-13	16.1	16.1	16.1	16.1	15.9	15.9	15.9	15.9
	-7	-7.6	16.6	16.6	16.6	16.6	16.4	16.4	16.4	16.4
	-4	-4.4	17.2	17.2	17.2	17.2	16.9	16.9	16.9	16.9
	0	-0.4	17.7	17.7	17.7	17.7	17.7	17.4	17.4	17.4
	5	4.5	20.0	19.7	19.5	19.5	19.5	19.5	19.5	19.5
	10	9	20.7	20.7	20.7	20.5	20.5	20.5	20.5	20.5
	15	14	22.0	22.0	22.0	22.0	22.0	22.0	21.8	21.5
	20	19	23.3	23.3	23.3	23.3	22.8	22.8	22.4	22.1
	25	23	24.3	24.3	24.3	24.3	24.3	23.8	23.6	22.4
	30	28	24.8	24.8	24.8	24.8	24.8	24.3	23.6	22.4
	35	32	25.6	25.6	25.6	25.6	25.3	24.8	23.6	22.4
	40	36	26.6	26.6	26.6	26.6	25.6	24.8	23.6	22.4
	45	41	27.7	27.7	27.7	26.9	25.6	24.8	23.6	22.4
	47	43	28.7	28.4	28.2	26.9	25.6	24.8	23.6	22.4
	50	46	30.7	29.4	28.2	26.9	25.6	24.8	23.6	22.4
55	51	31.4	29.7	28.2	26.9	25.6	24.8	23.6	22.4	
60	56	31.4	29.7	28.2	26.9	25.6	24.8	23.6	22.4	

TC: Total Capacity (MBh).
 The System Combination Ratio must be between 50–130%.
 Rated capacity is certified under AHRI Standard 1230. Ratings are subject to change without notice.

Current certified ratings are available at www.ahrirectory.org.
 For outdoor unit performance data, see the respective outdoor unit performance data manuals on <https://ghvac.com/commercial>.

Note:

Low ambient performance with LGRED° heat technology is included in Multi V 5 Air Source Units produced after February 2019.

STANDARD WALL-MOUNTED



Heating Capacity Tables

ARNU303SVA4

Table 58: ARNU303SVA4 Heating Capacity Table.

Model No. / Capacity Index	Outdoor Air Temp.		Indoor Air Temperature (°F DB)							
			59	61	64	67	70	73	76	80
	°F DB	°F WB	TC	TC	TC	TC	TC	TC	TC	TC
ARNU303SVA4/ 30.0	-21.6	-22.0	16.2	16.2	16.2	16.2	16.0	16.0	16.0	16.0
	-17.1	-17.5	18.2	18.2	18.2	18.2	17.9	17.9	17.9	17.9
	-12.6	-13	20.2	20.2	20.2	20.2	19.9	19.9	19.9	19.9
	-7	-7.6	20.8	20.8	20.8	20.8	20.5	20.5	20.5	20.5
	-4	-4.4	21.4	21.4	21.4	21.4	21.1	21.1	21.1	21.1
	0	-0.4	22.1	22.1	22.1	22.1	22.1	21.8	21.8	21.8
	5	4.5	25.0	24.6	24.3	24.3	24.3	24.3	24.3	24.3
	10	9	25.9	25.9	25.9	25.6	25.6	25.6	25.6	25.6
	15	14	27.5	27.5	27.5	27.5	27.5	27.5	27.2	26.9
	20	19	29.1	29.1	29.1	29.1	28.5	28.5	28.0	27.7
	25	23	30.4	30.4	30.4	30.4	30.4	29.8	29.4	28.0
	30	28	31.0	31.0	31.0	31.0	31.0	30.4	29.4	28.0
	35	32	32.0	32.0	32.0	32.0	31.7	31.0	29.4	28.0
	40	36	33.3	33.3	33.3	33.3	32.0	31.0	29.4	28.0
	45	41	34.6	34.6	34.6	33.6	32.0	31.0	29.4	28.0
	47	43	35.8	35.5	35.2	33.6	32.0	31.0	29.4	28.0
50	46	38.4	36.8	35.2	33.6	32.0	31.0	29.4	28.0	
55	51	39.2	37.1	35.2	33.6	32.0	31.0	29.4	28.0	
60	56	39.2	37.1	35.2	33.6	32.0	31.0	29.4	28.0	

TC: Total Capacity (MBh).

The System Combination Ratio must be between 50–130%.

Rated capacity is certified under AHRI Standard 1230. Ratings are subject to change without notice.

Current certified ratings are available at www.ahrirectory.org.

For outdoor unit performance data, see the respective outdoor unit performance data manuals on <https://lghvac.com/commercial>.

Note:

Low ambient performance with LGRED° heat technology is included in Multi V 5 Air Source Units produced after February 2019.



Table 59: ARNU363SVA4 Heating Capacity Table.

Model No. / Capacity Index	Outdoor Air Temp.		Indoor Air Temperature (°F DB)							
			59	61	64	67	70	73	76	80
	°F DB	°F WB	TC	TC	TC	TC	TC	TC	TC	TC
			MBh	MBh	MBh	MBh	MBh	MBh	MBh	MBh
ARNU363SVA4 / 36.2	-21.6	-22.0	18.8	18.8	18.8	18.8	18.5	18.5	18.5	18.5
	-17.1	-17.5	21.0	21.0	21.0	21.0	20.7	20.7	20.7	20.7
	-12.6	-13	23.3	23.3	23.3	23.3	23.0	23.0	23.0	23.0
	-7	-7.6	24.1	24.1	24.1	24.1	23.7	23.7	23.7	23.7
	-4	-4.4	24.8	24.8	24.8	24.8	24.4	24.4	24.4	24.4
	0	-0.4	25.5	25.5	25.5	25.5	25.5	25.2	25.2	25.2
	5	4.5	28.9	28.5	28.1	28.1	28.1	28.1	28.1	28.1
	10	9	30.0	30.0	30.0	29.6	29.6	29.6	29.6	29.6
	15	14	31.8	31.8	31.8	31.8	31.8	31.8	31.5	31.1
	20	19	33.7	33.7	33.7	33.7	32.9	32.9	32.4	32.0
	25	23	35.2	35.2	35.2	35.2	35.2	34.4	34.0	32.4
	30	28	35.9	35.9	35.9	35.9	35.9	35.2	34.0	32.4
	35	32	37.0	37.0	37.0	37.0	36.6	35.9	34.0	32.4
	40	36	38.5	38.5	38.5	38.5	37.0	35.9	34.0	32.4
	45	41	40.0	40.0	40.0	38.9	37.0	35.9	34.0	32.4
	47	43	41.4	41.1	40.7	38.9	37.0	35.9	34.0	32.4
50	46	44.4	42.6	40.7	38.9	37.0	35.9	34.0	32.4	
55	51	45.3	42.9	40.7	38.9	37.0	35.9	34.0	32.4	
60	56	45.3	42.9	40.7	38.9	37.0	35.9	34.0	32.4	

TC: Total Capacity (MBh).
 The System Combination Ratio must be between 50–130%.
 Rated capacity is certified under AHRI Standard 1230. Ratings are subject to change without notice.

Current certified ratings are available at www.ahrirectory.org.
 For outdoor unit performance data, see the respective outdoor unit performance data manuals on <https://lghvac.com/commercial>.

Note:
 Low ambient performance with LGRED° heat technology is included in Multi V 5 Air Source Units produced after February 2019.

Standard Wall-Mounted

APPLICATION GUIDELINES

Selecting the Best Location on page 115

General Mounting on page 116

General Drain Piping Information on page 118

Wiring Guidelines on page 120

Wired Remote Controller Location on page 122

Acronyms on page 123

Selecting the Best Location

Do's

- Place the unit where air circulation will not be blocked.
- Place the unit where drainage can be obtained easily.
- Place the unit where noise prevention is taken into consideration.
- Ensure there is sufficient space from the ceiling and floor.
- Ensure there is sufficient maintenance space.
- Locate the indoor unit in a location where it can be easily connected to the outdoor unit / heat recovery unit.

⊘ Don'ts

- Avoid installing the unit near high-frequency generators.
- Do not install the unit near a doorway.
- The unit must not be installed near a heat or steam source, or where considerable amounts of oil, iron powder, or flour are used. (These materials may generate condensate, cause a reduction in heat exchanger efficiency, or the drain to malfunction. If this is a potential problem, install a ventilation fan large enough to vent out these materials.)

⚠ WARNING

The unit must not be installed where sulfuric acid and flammable or corrosive gases are generated, vented into, or stored. There is risk of fire, explosion, and physical injury or death.

The unit may be damaged, may malfunction, and / or will not operate as designed if installed in any of the conditions listed.

Note:

- Indoor units (IDUs) must not be placed in an environment where the IDUs may be exposed to harmful volatile organic compounds (VOCs) or in environments where there is improper air make up or supply or inadequate ventilation. If there are concerns about VOCs in the environment where the IDUs are installed, proper air make up or supply and/or adequate ventilation must be provided. Additionally, in buildings where IDUs will be exposed to VOCs, consider a third party factory-applied epoxy coating to the fan coils for each IDU where the entire coil is dipped, not sprayed.
- If the unit is installed near a body of water, the installation parts are at risk of corroding. Appropriate anti-corrosion methods must be taken for the unit and all installation parts.

Installing in an Area Exposed to Unconditioned Air

In some installation applications, areas (floors, walls) in some rooms may be exposed to unconditioned air (room may be above or next to an unheated garage or storeroom). To countermeasure:

- Verify that carpet is or will be installed (carpet may increase the temperature by three [3] degrees).
- Add insulation between the floor joists.
- Install radiant heat or another type of heating system to the floor.

Figure 49: Minimum Clearance Requirements for SF Frame Gallery Indoor Units.

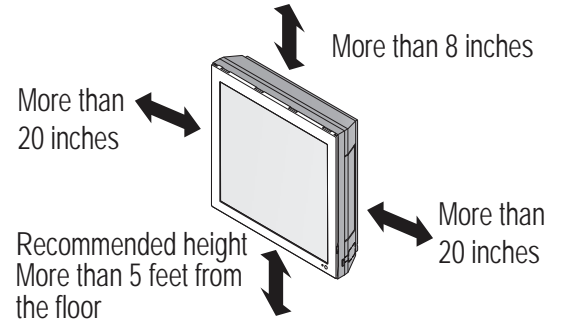

Figure 50: Minimum Clearance Requirements for SJ, SK, SV Frame Wall-Mounted Indoor Units.

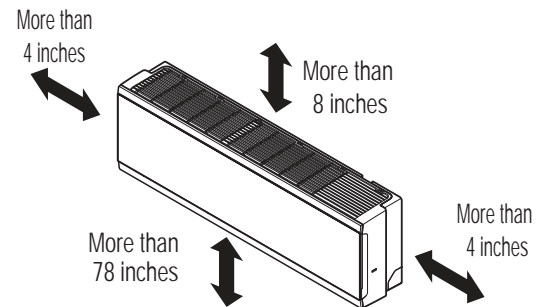
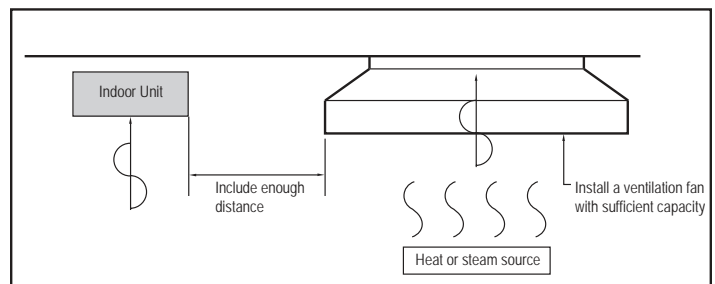

Figure 51: Installing Near a Heat or Steam Source.



General Mounting

General Mounting - Gallery

Using the Installation Guide

1. Choose an appropriate location for the indoor unit. To hang the installation guide, verify that it is level and plumb, and then tape it to the wall.
2. Drill four (4) 1/4-inch diameter holes with a depth of 1-3/16 to 1-3/8 inches for the mounting screws. Drill one (1) two (2) inch-diameter hole for the field-installed refrigerant and drain piping.
3. Insert a plastic anchor into each of the mounting holes.
4. Screw the top two (2) screws into the wall. Do not flush them to the wall; leave a 7/16 inch space for hanging the indoor unit.

Figure 52: Using the SF Frame Gallery Indoor Unit Installation Guide.

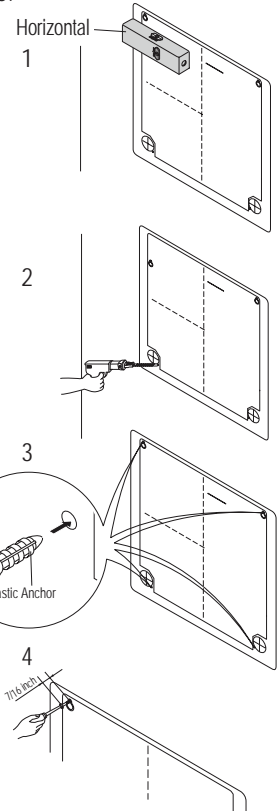

Preparing the Gallery Indoor Unit Refrigerant and Drain Piping Connections

1. Depending on the installation requirements, there is a choice of routing the Gallery indoor unit refrigerant piping and drain hose to the left, right, or rear of the frame. If installing piping on the right side of the Gallery indoor unit frame, first press on the top of the clamp, and then slowly guide the piping downward. Then, bend the piping to the right side of the indoor unit frame.

Figure 53: SF Frame Gallery Indoor Unit Right Side Piping Access.

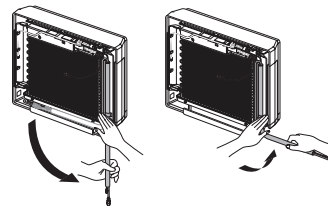

Note:

⚠ Do not bend the piping / drain hose from side to side, it may damage the components.

2. Bundle the piping and drain hose with tape where they meet near the indoor unit frame. Position the drain hose at the bottom of the bundle (positioning the drain hose at the top of the bundle may cause the drain pan to overflow inside the indoor unit).

Hanging the Gallery Indoor Unit Frame

1. Remove the installation guide and hang the indoor unit on the top two (2) screws. Verify the indoor unit is hanging securely on the screws.
2. Align the holes at the bottom of the indoor unit to the mounting holes. Tighten first the top screws, then tighten the bottom screws.
3. Verify that the indoor unit is completely secured to the wall by gently shaking it up and down.

Figure 54: Hanging the SF Frame Gallery Indoor Unit.

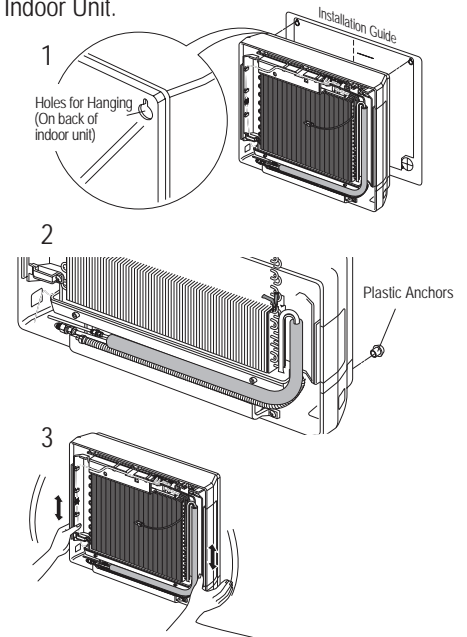

General Drain Piping Information

General Drain Piping Information

All Gallery and Wall mounted indoor units generate water during cooling operation, therefore, properly handling this condensation must be considered. Gallery and Wall-mounted indoor units apply the gravity drain method, but a field-supplied condensate pump can be installed (optional, sold separately). Depending on the location of the indoor unit, condensation can be drained directly to the outside of the building, or a common indoor unit drainage piping system can be installed.

Drain Hose

All condensate piping is to be installed per applicable local codes. Avoid any contact with building sewer lines and vent lines.

Gallery and Wall mounted indoor units have a built-in drain hose. If necessary, the drain hose can be extended. When the bottom surface of the indoor unit is at an elevation below the receiving drain line connection, install an inverted trap at the top of the condensate pump discharge riser before connection to the drain pipe.

When the receiving drain line is mounted horizontal, connect the inverted trap to the top half of the pipe. The connection point of the inverted trap to the drain pipe must always be to the top half of the pipe and must never be over 45° either side of the upper most point of the horizontal drain line.

If connecting to a vertical drain line, connect the IDU condensate pump discharge line using a Y-45 fitting with the double end of the Y-45 fitting facing up. When connecting to a vertical drain line include an inverted trap at the top of the IDU condensate pump discharge riser before connection to the Y-45 fitting.

Drain Piping

- Drain piping must have down slope (1/50 to 1/100).
- Any holes through the ceilings, walls, etc., must be large enough to accommodate the drain piping and insulation.

- To prevent reversal flow, do not provide up and down slope.
- Do not exert extra force on the drain port on the indoor unit during drain piping connection.

Drain Leak Test

A leak test must be performed 24 hours after the drainage system has been installed.

Drain Pipe Insulation

Install field supplied polyethylene foam insulation 5/16 inch thick or greater on the flexible drain pipe and position snugly against indoor unit.

Note:

Ensure the indoor unit, refrigerant piping, power wiring / communication cables, and drain piping is properly supported with anchor bolts and clamp hangers positioned at 3.3 to 4.9 foot intervals.

Figure 60: Diagram of an Indoor Unit with a Gravity Drain.

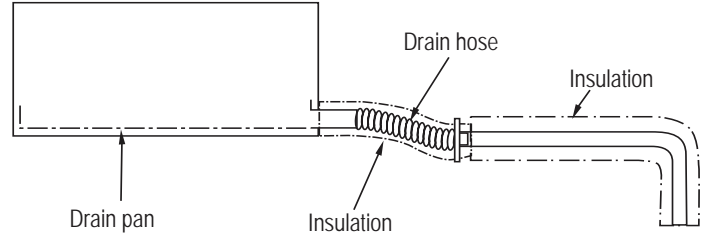
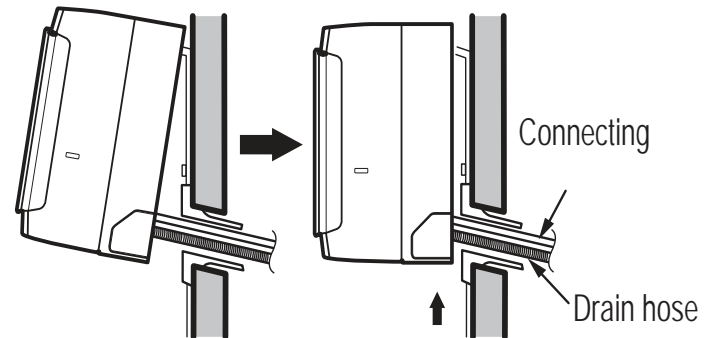

Table 60: Indoor Unit Drain Piping Specifications.

Indoor Unit	Drain Type	Drain Pipe Diameter (ID, in.)
SF Frame Gallery	Gravity	Ø5/8
SJ Frame Wall Mounted		
SK Frame Wall Mounted		
SV Frame Wall Mounted		

Figure 61: Drain Piping Slope.



Common Indoor Unit Drainage System

It is usual work practice to connect individual indoor unit drain pipes to one common indoor unit drainage system. The diameter of the common vertical drain pipe must be as large as necessary. The diameter of the horizontal pipe must be the same or larger than the vertical drain pipe. To avoid property damage in the event of the primary drain becoming clogged, and to optimize drain system performance, it may be prudent to install a secondary drain line. Design the drain system to plan for winter operation (condensate line may freeze up if condensate does not properly drain away). Drain all generated condensate from the external condensate pan to an appropriate area. Install a trap in the condensate lines as near to the indoor unit coil as possible. To prevent overflow, the outlet of each trap must be positioned below its connection to the condensate pan. All traps must be primed, insulated, and leak tested if located above an inhabited space.

Figure 62: Example of a Common Indoor Unit Drainage System.

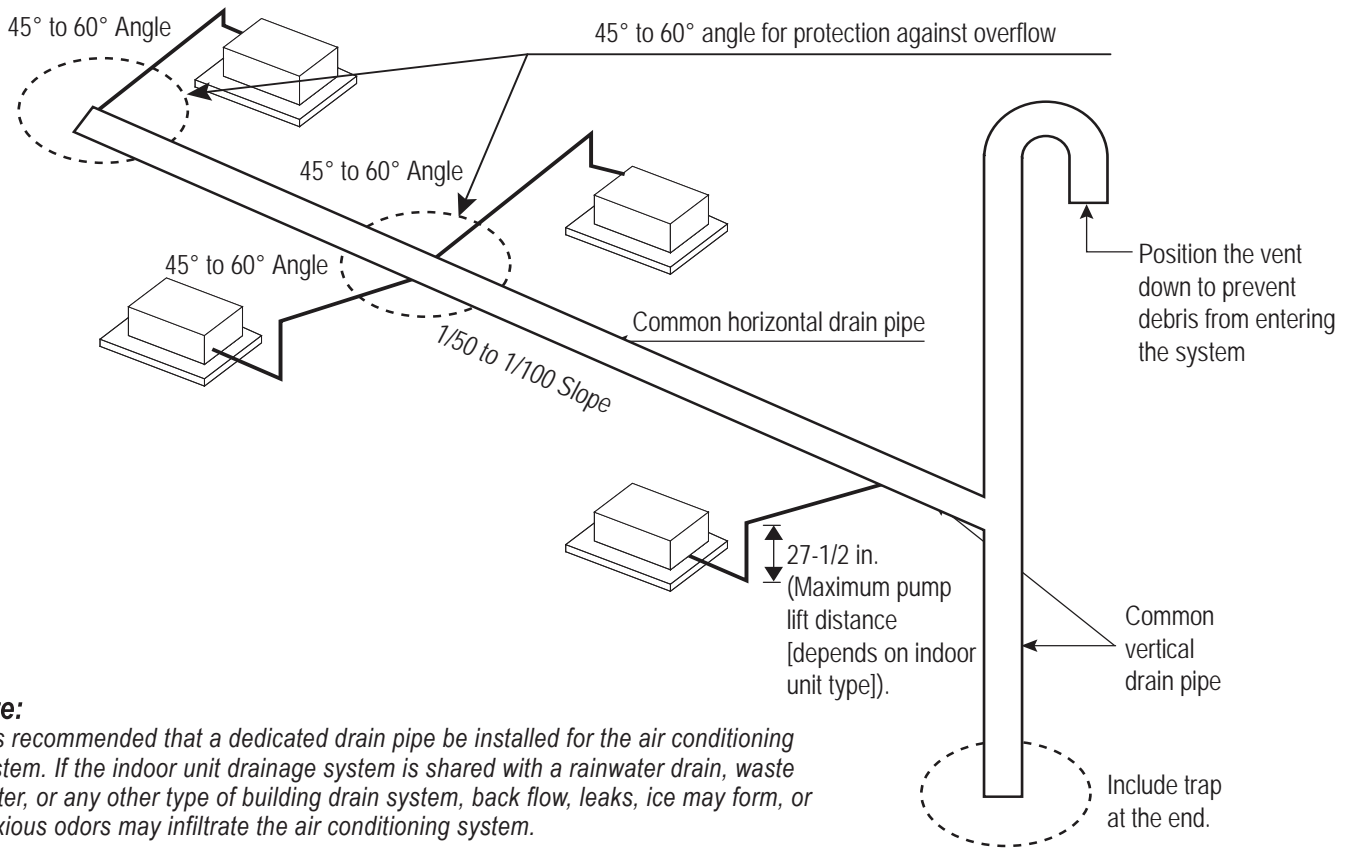

Note:

- It is recommended that a dedicated drain pipe be installed for the air conditioning system. If the indoor unit drainage system is shared with a rainwater drain, waste water, or any other type of building drain system, back flow, leaks, ice may form, or noxious odors may infiltrate the air conditioning system.
- Install a trap if the drain access to the outside faces an undesirable location (i.e., sewer), otherwise, noxious odors may infiltrate the air conditioning system.

General Power Wiring / Communications Cable Guidelines

- Follow manufacturer's circuit diagrams displayed on the inside of the control box cover.
- Have a separate power supply for the indoor units.
- Provide a circuit breaker switch between the power source and the indoor unit.
- Confirm power source specifications.
- Confirm that the electrical capacity is sufficient.
- Starting current must be maintained ± 10 percent of the rated current marked on the name plate.
- Confirm wiring / cable thickness specifications:
 - Power wiring is field supplied. Wire size is selected based on the larger MCA value, and must comply with the applicable local and national codes.
 - Communication cable between main ODU to IDUs / HRUs to be 18 AWG, 2-conductor, twisted, stranded, shielded. Ensure the communication cable shield is properly grounded to the main ODU chassis only. Ⓞ Do not ground the ODU to IDUs / HRUs communication cable at any other point. Wiring must comply with all applicable local and national codes.
- It is recommended that a circuit breaker is installed, especially if conditions could become wet or moist.
- Include a disconnect in the power wiring system, add an air gap contact separation of at least 1/8 inch in each active (phase) conductor.
- Any openings where the field wiring enters the cabinet must be completely sealed.

WARNING

- Terminal screws may loosen during transport. Properly tighten the terminal connections during installation or risk electric shock, physical injury or death.
- Loose wiring may cause unit the wires to burnout or the terminal to overheat and catch fire. There is a risk of electric shock, physical injury or death.

Note:

- Terminal screws may loosen during transport. Properly tighten the terminal connections during installation or risk equipment malfunction or property damage.
- Loose wiring may cause unit malfunction, the wires to burnout or the terminal to overheat and catch fire. There is a risk of equipment malfunction or property damage.

A voltage drop may cause the following problems:

- Magnetic switch vibration, fuse breaks, or disturbance to the normal function of an overload protection device.
- Compressor will not receive the proper starting current.

Power Wiring and Communications Cable Connections

1. Insert the power wiring / communications cable from the outdoor unit or heat recovery unit (Heat Recovery systems only) through the access hole of the indoor unit (ground wire must be longer than the other wires / cables) and to the control board using the designated path. If a control board cover is present, detach it.
2. Connect each wire to its appropriate terminal on the indoor unit control board. Verify that the color and terminal numbers from the outdoor unit or heat recovery unit (Heat Recovery systems only) wiring match the color and terminal numbers on the indoor unit.
3. Secure the power wiring / communications cable to the control board. If a control board cover is present, reattach it.

Figure 63: Location of Power Wiring / Communications Cable Terminals in SF Frame Gallery Indoor Units.

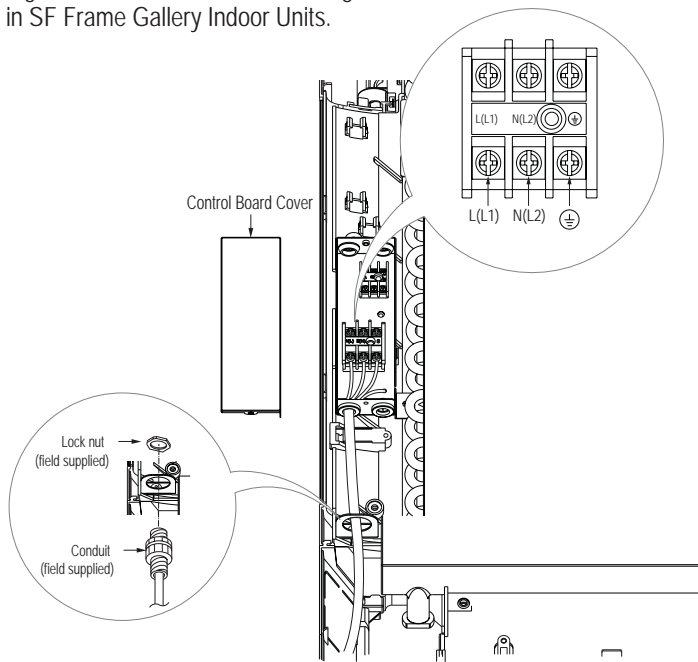

Figure 64: Location of Power Wiring / Communications Cable Terminals in SJ and SK Frame Indoor Units.

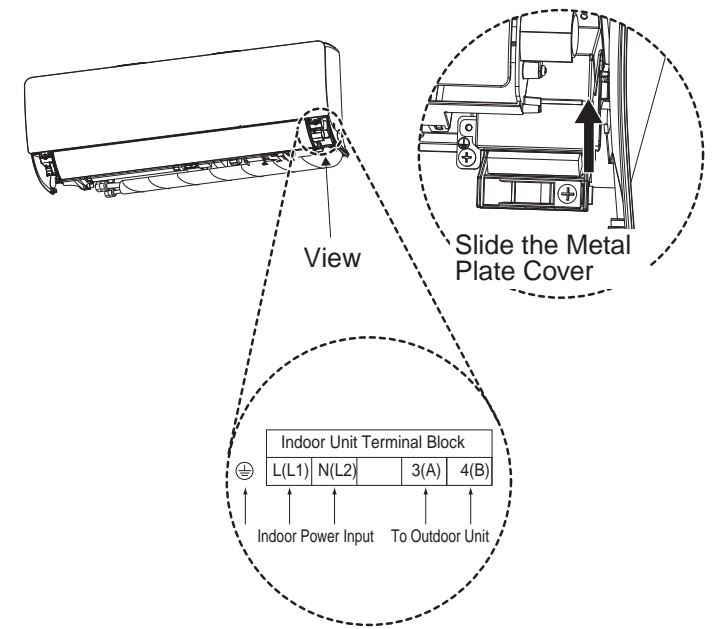
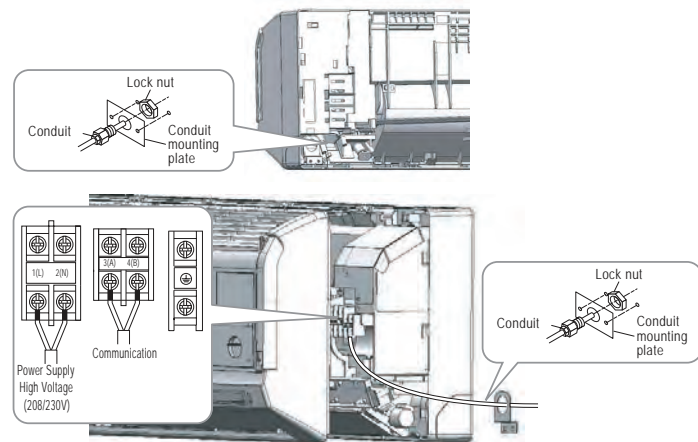

Figure 65: Location of Power Wiring / Communications Cable Terminals in SV Frame Indoor Units.



Wiring Guidelines

Figure 66: Simplified View of Indoor Unit Terminal Connections—SF Gallery Frames.

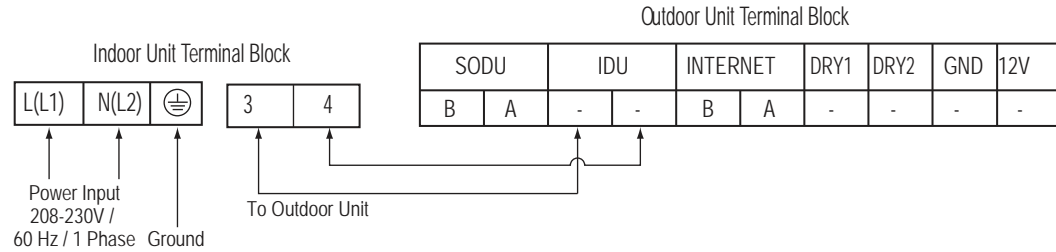

Figure 67: Simplified View of Indoor Unit Terminal Connections—SJ and SK Frames.

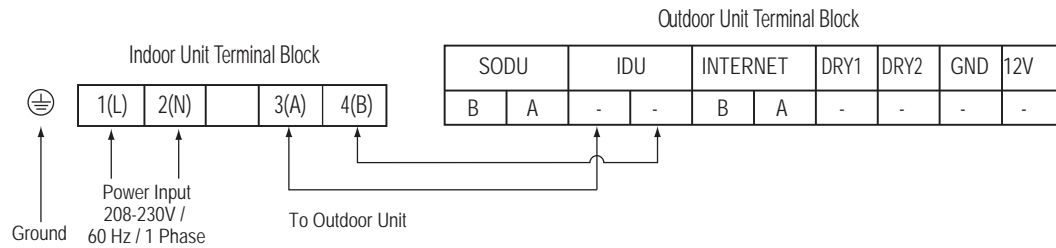
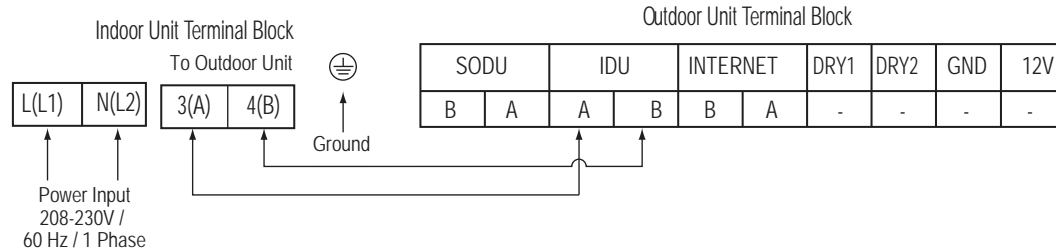

Figure 68: Simplified View of Indoor Unit Terminal Connections—SV Frames.



Wired Controller Placement

Gallery and Wall-mounted indoor units can be used with various wired controllers (optional; sold separately). Wired controllers include a sensor to detect room temperature. To maintain comfort levels in the conditioned space, the wired controller must be installed in a location away from direct sunlight, high humidity, and where it could be directly exposed to cold air. Controller must be installed four (4) to five (5) feet above the floor where its LED display can be read easily, in an area with good air circulation, and where it can detect an average room temperature.

- ⊘ Do not install the wired controller near or in:
- Drafts or dead spots behind doors and in corners
 - Hot or cold air from ducts
 - Radiant heat from the sun or appliances
 - Concealed pipes and chimneys
 - An area where temperatures are uncontrolled, such as an outside wall

Figure 69: Proper Location for the Wired Controller.

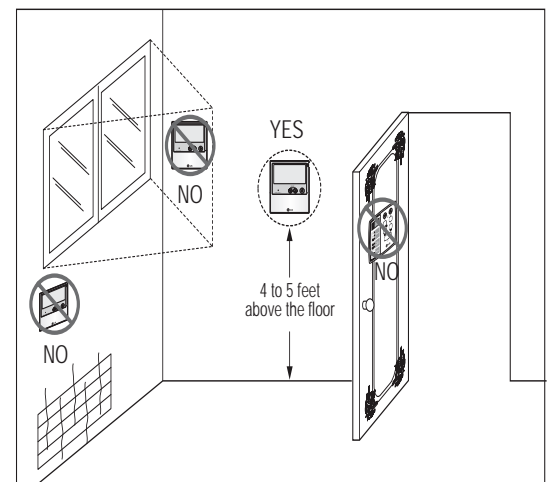

Table 61: Acronym Table.

ABS	Acrylonitrile Butadiene Styrene	IDU	Indoor Unit
AC	Air Conditioner/Alternate Current	kW	Kilowatts
ACP	Advanced Control Platform	in Aq	inches water
AHU	Air Handling Unit	ISO	International Standards Organization
ASHRAE	American Society of Heating, Refrigeration, and Air Conditioning	LATS	LG Air Conditioning Technical Solution software
ASTM	American Society for Testing and Materials	LED	Light Emitting Diode
AWG	American Wire Gauge	LEED	Leadership in Energy and Environmental Design
AWHP	Air-to-Air Water Heat Pump	MBh	Thousands BTUs per hour
BLDC	Brushless Digitally-Controlled	MCA	Minimum Circuit Ampacity
BTL	BACnet® Testing Laboratories	mm	Millimeter
Btu/h	British Thermal Unit per Hour	MOP	Maximum Overcurrent Protection
CAA	Clean Air Act	OD	Outside Diameter
CFM	Cubic Feet per Minute	ODU	Outdoor Unit
CFR	Code of Federal Regulations	PI	Power Input
DB	Dry Bulb	PTAC	Packaged Terminal Air Conditioner
dB(A)	Decibels with "A" frequency weighting	SHC	Sensible Heat Capacity
DPST	Double-Pole Single Throw	SMACNA	Sheet Metal & Air Conditioning Contractors' National Association
DX	Direct expansion	RPM	Revolutions per Minute
EEV	Electric Expansion valve	TC	Total Capacity
EPDM	Ethylene Propylene Diene M-Class Rubber	USD	United States Dollar
EMF	Electromagnetic Field	UL	Underwriters Laboratories
ESP	External Static Pressure	V	Voltage
ETL	Electric Testing Laboratories	VAV	Variable Air Volume
GND	Ground	VRF	Variable Refrigerant Flow
H/M/L	High/Medium/Low	W	Watts
HVAC	Heating, Ventilating and Air Conditioning	WB	Wet Bulb
Hz	Hertz	wg	Water Gauge
ID	Inside Diameter		

Inverter



LG Electronics, U.S.A., Inc.
Air Conditioning Technologies
4300 North Point Parkway
Alpharetta, Georgia 30022
www.lghvac.com

EM_MultiV_Wall_Mounted_IndoorUnits_03_23
Supersedes: EM_MultiV_Wall_Mounted_IndoorUnits_10_20
EM_MultiV_Wall_Mounted_IndoorUnits_10_19
EM_MultiV_WallMounted_IndoorUnits_06_19
EM_MultiV_WallMounted_IndoorUnits_7_18A
EM_MultiV_WallMounted_IndoorUnits_4_18A
EM_MultiV_WallMounted_IndoorUnits_4_18
EM_MultiV_WallMounted_IndoorUnits_8_17
EM_MultiV_WallMounted_IndoorUnits_3_16