



**RETAIN THESE INSTRUCTIONS
 FOR FUTURE REFERENCE**

⚠ WARNING

Improper installation, adjustment, alteration, service or maintenance can cause property damage, personal injury or loss of life. Installation and service must be performed by a qualified installer or service agency.

⚠ CAUTION

Physical contact with metal edges and corners while applying excessive force or rapid motion can result in personal injury. Be aware of, and use caution when working near these areas during installation or while servicing this equipment.

⚠ IMPORTANT

This unit must be matched with an indoor coil as specified in Lennox' Engineering Handbook. Coils previously charged with HCFC-22 must be flushed.

⚠ IMPORTANT

The Clean Air Act of 1990 bans the intentional venting of refrigerant (CFC's, HCFC's AND HFC's) as of July 1, 1992. Approved methods of recovery, recycling or reclaiming must be followed. Fines and/or incarceration may be levied for noncompliance.

INSTALLATION INSTRUCTIONS

HSXA16 Series Units

CONDENSING UNITS
 504,953M
 07/06
 Supersedes 03/06

TP Technical
 Publications
 Litho U.S.A.

Table of Contents

HSXA16 Outdoor Unit	1
Shipping & Packing List	1
General Information	2
Unit Dimensions	2
Setting The Unit	3
Electrical	3
Refrigerant Piping	5
Refrigerant Metering Device	8
Flushing Existing Line Set & Indoor Coil	8
Manifold Gauge Set	9
Service Valves	10
Leak Testing	11
Evacuation	11
Start-Up	12
Refrigerant Charging	12
System Operation	14
Maintenance	15
Optional Accessories	15
Homeowner Information	15
Thermostat Operation	16
Start-up & Performance Check List	16

HSXA16 Outdoor Unit

Two-stage HSXA16 outdoor units use HFC-410A refrigerant. This unit must be installed with a matching indoor coil and line set as outlined in the Lennox Engineering Handbook. Elite® Series HSXA16 outdoor units are designed for use in thermostatic expansion valve (TXV) systems only and are not for use with other refrigerant flow control devices. The Lennox Engineering Handbook lists a TXV kit that must be ordered separately.

Shipping & Packing List

- 1 - Assembled HSXA16 outdoor unit
- 2 - Grommets (liquid and vapor line)
- 1 - Bushing (for low voltage wiring)

Check equipment for shipping damage. If you find any damage, immediately contact the last carrier.



Unit Dimensions - inches (mm)

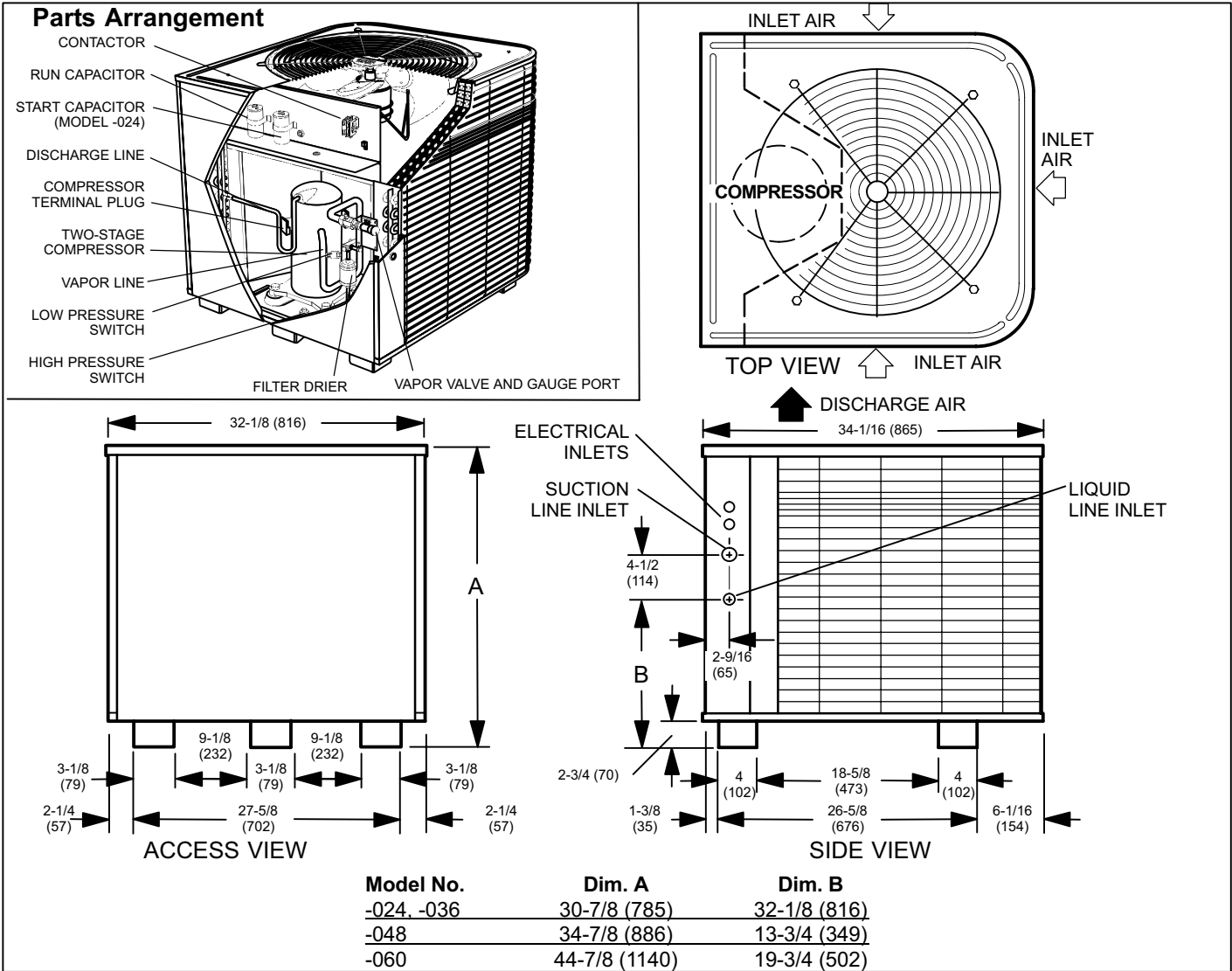

⚠ WARNING

This product and/or the indoor unit it is matched with may contain fiberglass wool.

Disturbing the insulation during installation, maintenance, or repair will expose you to fiberglass wool dust. Breathing this may cause lung cancer. (Fiberglass wool is known to the State of California to cause cancer.)

Fiberglass wool may also cause respiratory, skin, and eye irritation.

To reduce exposure to this substance or for further information, consult material safety data sheets available from address shown below, or contact your supervisor.

Lennox Industries Inc.
P.O. Box 799900
Dallas, TX 75379-9900

General Information

These instructions are intended as a general guide and do not supersede national or local codes in any way. Consult authorities having jurisdiction before installation.

When servicing or repairing HVAC components, ensure caps and fasteners are appropriately tightened. Table 1 lists torque values for typical service/repair items.

Table 1

Torque Requirements		
Part	Recommended Torque	
Service valve cap	8 ft.- lb.	11 NM
Gauge port seal cap	8 ft.- lb.	11 NM
Sheet metal screws	16 in.- lb.	2 NM
Machine screws #10	28 in.- lb.	3 NM
Compressor bolts	90 in.- lb.	10 NM

Setting the Unit

Refer to unit dimensions for sizing mounting slab, platforms or supports. See figure 1 for installation clearances.

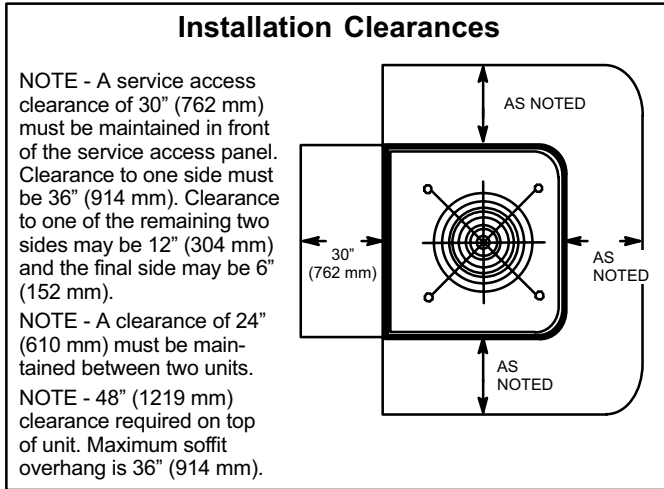

Figure 1

CAUTION

In order to avoid injury, take proper precaution when lifting heavy objects.

Slab Mounting

When installing a unit at grade level, the top of the slab should be high enough above the grade so that water from higher ground would not collect around the unit. See figure 2. Slab may be level or have a slope tolerance away from the building of not more than 2 degrees or 2 inches per 5 feet (51 mm per 1524 mm).

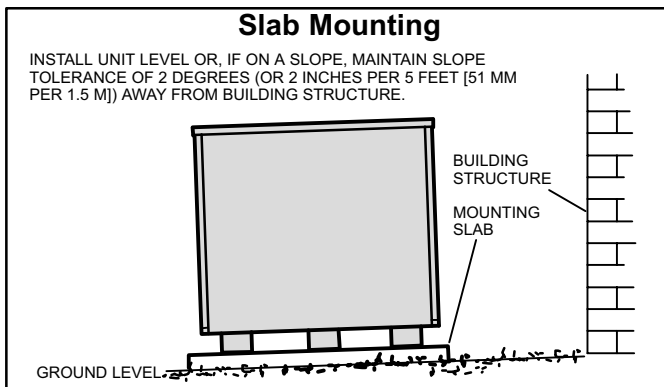

Figure 2

Roof Mounting

Install the unit a minimum of 6 inches (152 mm) above the roof surface to avoid ice build-up around the unit. Locate the unit above a load bearing wall or area of the roof that can adequately support the unit. Consult local codes for rooftop applications.

Electrical

WARNING

Electric Shock Hazard.

Can cause injury or death.

Unit must be grounded in accordance with national and local codes.

Line voltage is present at all components when unit is not in operation on units with single-pole contactors. Disconnect all remote electric power supplies before opening access panel. Unit may have multiple power supplies.



In the U.S.A., wiring must conform with current local codes and the current National Electric Code (NEC). In Canada, wiring must conform with current local codes and the current Canadian Electrical Code (CEC).

Refer to the furnace or blower coil installation instructions for additional wiring application diagrams and refer to unit nameplate for minimum circuit ampacity and maximum overcurrent protection size.

1. Install line voltage power supply to unit from a properly sized disconnect switch.
2. Ground unit at unit disconnect switch or to an earth ground.

NOTE - Connect conduit to the unit using a proper conduit fitting.

NOTE - Units are approved for use only with copper conductors. 24V, Class II circuit connections are made in the low voltage junction box. Refer to appropriate figure for field wiring. See figure 3 for field wiring. See figures 4 and 3 for typical wiring.

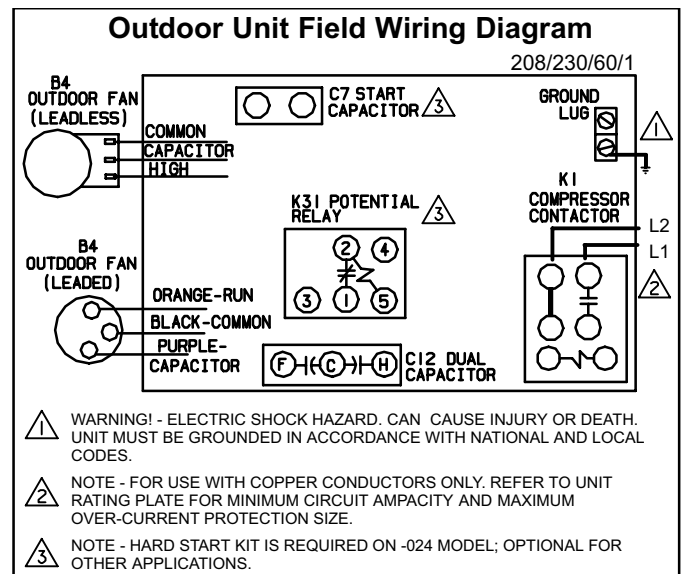

Figure 3

NOTE - A complete unit wiring diagram is located inside the unit control box cover.

3. Install room thermostat (ordered separately) on an inside wall approximately in the center of the conditioned area and 5 feet (1.5 m) from the floor. It should not be installed on an outside wall or where it can be affected by sunlight, drafts or vibrations.
4. Install low voltage wiring from outdoor to indoor unit and from thermostat to indoor unit.

NOTE - For proper voltages, select thermostat wire gauge per the following chart:

Wire run length	AWG #	Insulation type
less than 100' (30m)	18	color-coded, temperature rating 35°C minimum
more than 100' (30m)	16	

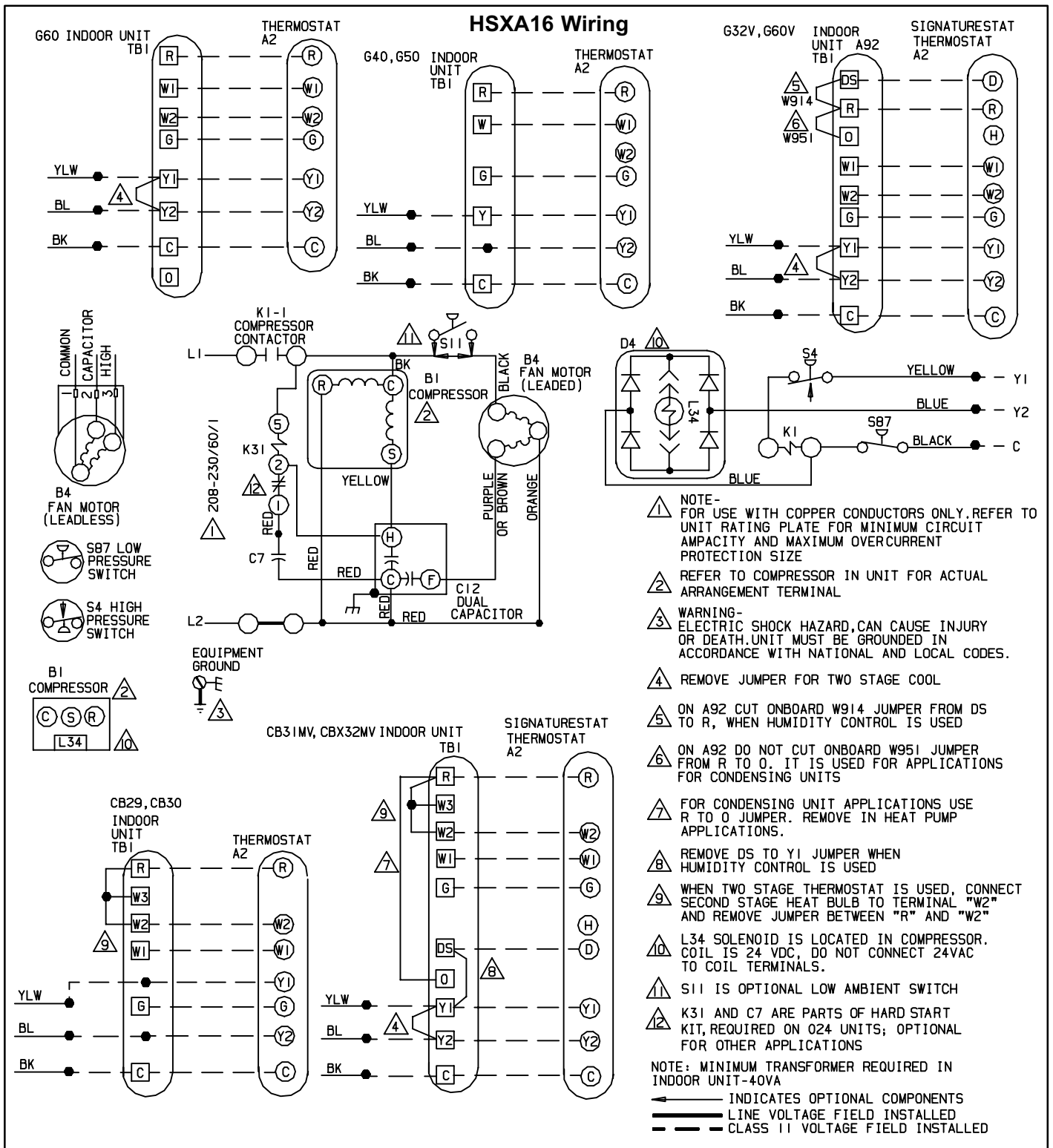

Figure 4

Refrigerant Piping

If the HSXA16 unit is being installed with a new indoor coil and line set, the plumbing connections should be made as outlined in this section. If an existing line set and/or indoor coil is going to be used to complete the HSXA16 system, refer to the following section which includes flushing procedures.

Field refrigerant piping consists of liquid and vapor lines from the outdoor unit (sweat connections) to the indoor coil (flare or sweat connections). Use Lennox L15 (sweat, non-flare) series line sets as shown in table 2 or use field-fabricated refrigerant lines. Valve sizes are listed in table 2.

Table 2

Refrigerant Line Sets					
Model	Field Connections		Recommended Line Set		
	Liquid Line	Vapor Line	Liquid Line	Vapor Line	L15 Line Sets
-024 -036 -048	3/8 in. (10 mm)	7/8 in. (22 mm)	3/8 in. (10 mm)	7/8 in. (22 mm)	L15-65 15 ft. - 50 ft. (4.6 m - 15 m)
-060	3/8 in. (10 mm)	1-1/8 in. (29 mm)	3/8 in. (10 mm)	1-1/8 in. (29 mm)	Field Fabricated

NOTE - When installing refrigerant lines, refer to Lennox Refrigerant Piping Guide (Corp. 9351-L9) or Lennox Technical Support Product Applications for assistance. In addition, be sure to consider the following points:

- Select line set diameters from table 2 to ensure that oil returns to the compressor.
- Units are designed for line sets of up to fifty feet (15 m); for longer line sets, consult piping guidelines.
- Size vertical vapor riser to maintain minimum velocity at minimum capacity.

Refrigerant Line Connections—HSXA16 Matched with New Indoor Coil and Line Set

If an existing indoor coil that was equipped with an RFCI metering device is being replaced, the liquid line must also be replaced prior to the installation of the HSXA16 unit.

If refrigerant lines are routed through a wall, seal and isolate the opening so vibration is not transmitted to the building.

Installing Refrigerant Line

During the installation of any heat pump or a/c system, it is important to properly isolate the refrigerant lines to prevent unnecessary vibration. Line set contact with the structure (wall, ceiling or floor) causes some objectionable noise when vibration is translated into sound. As a result, more energy or vibration can be expected. Closer attention to line set isolation must be observed.

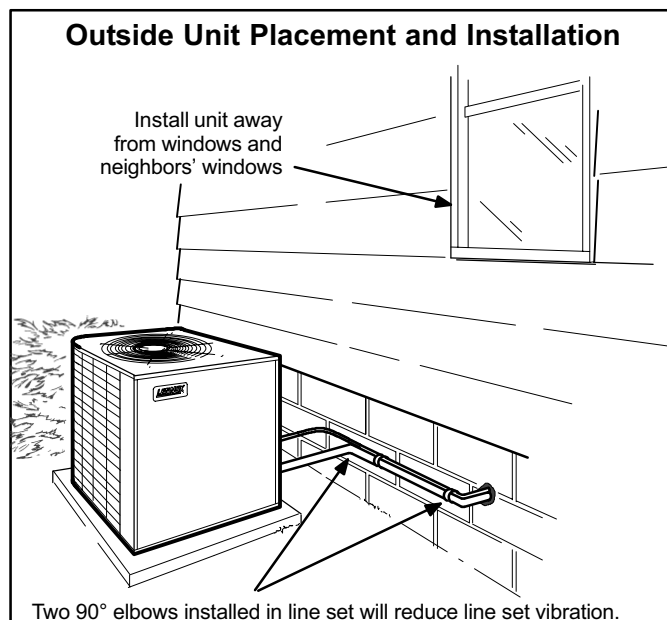

Figure 5

Following are some points to consider when placing and installing a high-efficiency outdoor unit:

1. **Placement**—Be aware some localities are adopting sound ordinances based on how noisy the unit is at the neighbors' home, not at the original installation. Install the unit as far as possible from the property line. When possible, do not install the unit directly outside a bedroom window. Glass has a very high level of sound transmission. Figure 5 shows how to place the outdoor unit and line set.
2. **Line Set Isolation**—The following illustrations demonstrate procedures which ensure proper refrigerant line set isolation. Figure 6 shows how to install line sets on horizontal runs. Figure 7 shows how to make a transition from horizontal to vertical. Figure 8 shows how to install line sets on vertical runs.

Refrigerant Line Sets: Installing Horizontal Runs

To hang line set from joist or rafter, use either metal strapping material or anchored heavy nylon wire ties.

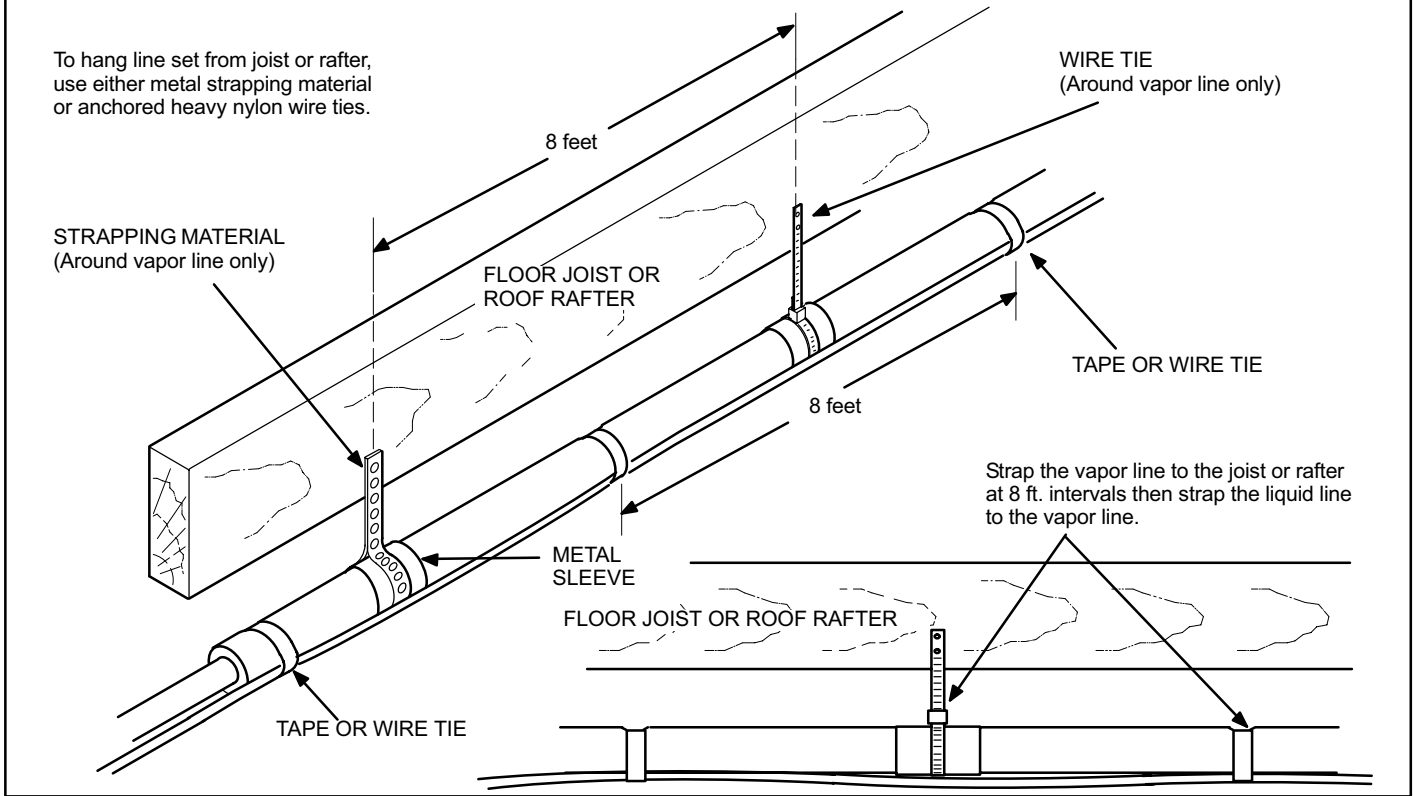

Figure 6

Refrigerant Line Sets: Transition From Vertical To Horizontal

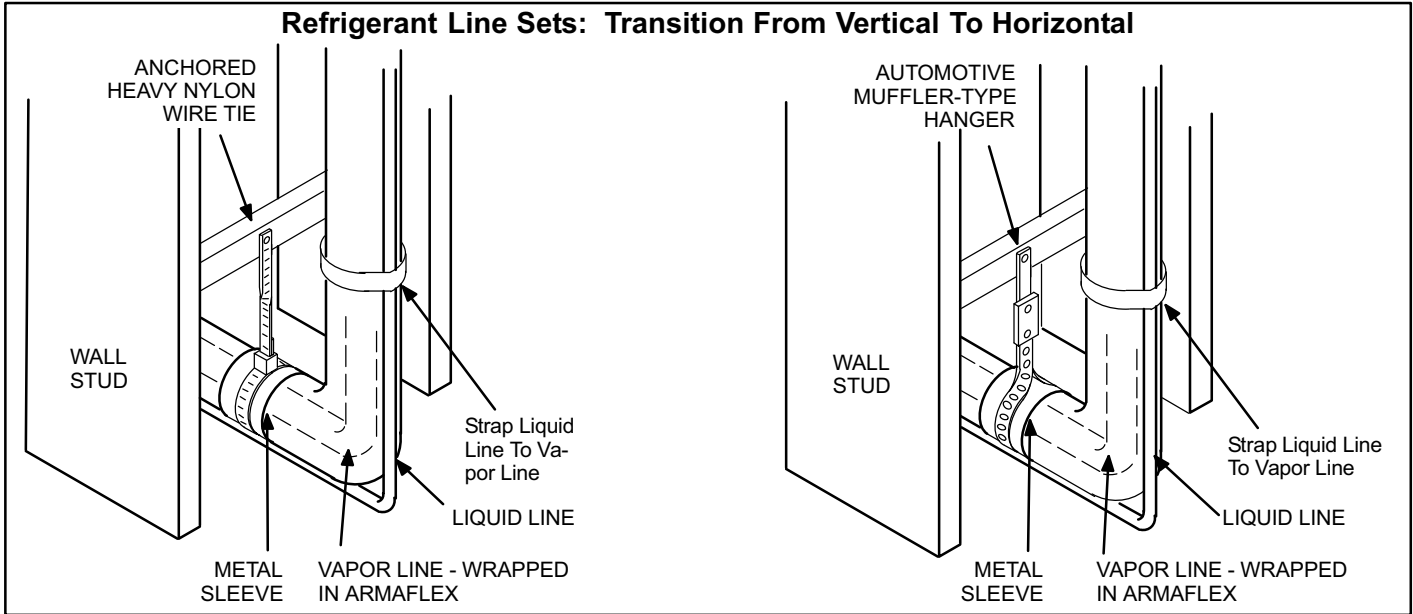

Figure 7

Refrigerant Line Sets: Installing Vertical Runs (new construction shown)

NOTE - Similar installation practices should be used if line set is to be installed on exterior of outside wall.

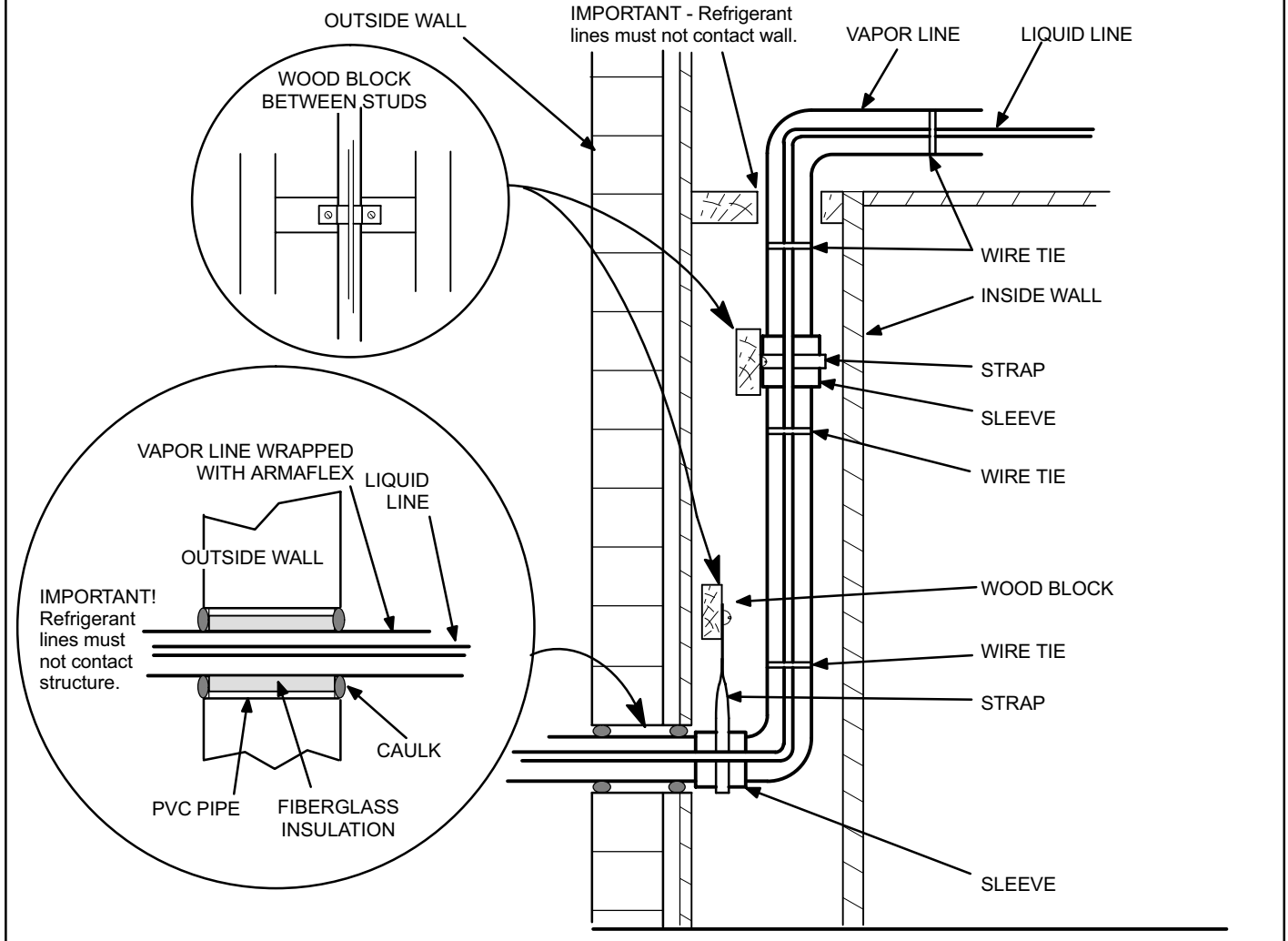

Figure 8

⚠ WARNING

Polyol ester (POE) oils used with HFC-410A refrigerant absorb moisture very quickly. It is very important that the refrigerant system be kept closed as much as possible. **DO NOT** remove line set caps or service valve stub caps until you are ready to make connections.

Brazing Connection Procedure

1. Cut ends of the refrigerant lines square (free from nicks or dents). Debur the ends. The pipe must remain round, do not pinch end of the line.
2. Before making line set connections, use dry nitrogen to purge the refrigerant piping. This will help to prevent oxidation and the introduction of moisture into the system.

3. Use silver alloy brazing rods (5 or 6 percent **minimum** silver alloy for copper-to-copper brazing or 45 percent silver alloy for copper-to-brass or copper-to-steel brazing) which are rated for use with HFC-410A refrigerant. Wrap a wet cloth around the valve body and the copper tube stub. Remove light maroon washers from service valves and shield light maroon stickers in order to protect them during brazing. Braze the line set to the service valve.

4. Wrap a wet cloth around the valve body and copper tube stub to protect it from heat damage during brazing. Wrap another wet cloth underneath the valve body to protect the base paint.

NOTE - The tube end must stay bottomed in the fitting during final assembly to ensure proper seating, sealing and rigidity.

5. Install the field-provided thermostatic expansion valve (approved for use with HFC-410A refrigerant) in the liquid line at the indoor coil.

Refrigerant Metering Device

HSXA16 units are used in thermostatic expansion valve (TXV) systems only. See the Lennox Engineering Handbook for approved TXV match-ups and application information.

Check expansion valves equipped with Chatleff fittings are available from Lennox. Refer to the Engineering Handbook for applicable expansion valves for use with specific match-ups.

If you install a thermostatic expansion valve (TXV) with an indoor coil that includes a fixed orifice, remove the orifice before installing the TXV. See figure 9 for installation of the TXV.

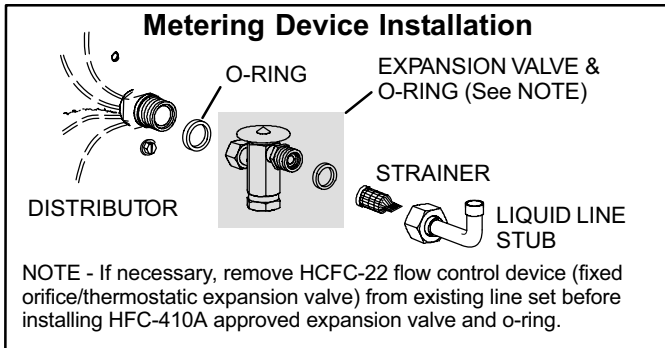

Figure 9

Flushing Existing Line Set & Indoor Coil

! WARNING



Danger of fire. Bleeding the refrigerant charge from only the high side may result in the low side shell and suction tubing being pressurized. Application of a brazing torch while pressurized may result in ignition of the refrigerant and oil mixture - check the high and low pressures before unbrazing.

NOTE - If the indoor unit line and set is new, skip this section and go on to the Manifold Gauge Set section.

! IMPORTANT

If this unit is being matched with an approved line set or indoor coil which was previously charged with mineral oil, or if it is being matched with a coil which was manufactured before January of 1999, the coil and line set must be flushed prior to installation. Take care to empty all existing traps. Polyol ester (POE) oils are used in Lennox units charged with HFC-410A refrigerant. Residual mineral oil can act as an insulator, preventing proper heat transfer. It can also clog the expansion device, and reduce the system performance and capacity. Failure to properly flush the system per the instructions below will void the warranty.

! IMPORTANT

The Environmental Protection Agency (EPA) prohibits the intentional venting of HFC refrigerants during maintenance, service, repair and disposal of appliance. Approved methods of recovery, recycling or reclaiming must be followed.

! CAUTION

This procedure should not be performed on systems which contain contaminants (Example: compressor burn out).

Required Equipment

You will need the following equipment in order to flush the existing line set and indoor coil: two clean HCFC-22 recovery bottles, an oilless recovery machine with a pump down feature, and two sets of gauges (one for use with HCFC-22 and one for use with the HFC-410A).

Flushing Procedure

1. Remove existing HCFC-22 refrigerant using the appropriate procedure below (see figure 10):

If the existing outdoor unit is not equipped with shut-off valves, or if the unit is not operational AND you plan to use the existing HCFC-22 refrigerant to flush the system -

- Disconnect all power to the existing outdoor unit.
- Connect to the existing unit, a **clean** recovery cylinder and the recovery machine according to the instructions provided with the recovery machine.
- Remove all HCFC-22 refrigerant from the existing system. Check gauges after shutdown to confirm that the entire system is completely void of refrigerant.
- Disconnect the liquid and vapor lines from the existing outdoor unit.

If the existing outdoor unit is equipped with manual shut-off valves AND you plan to use NEW HCFC-22 refrigerant to flush the system -

- Start the existing HCFC-22 system in the cooling mode and close the liquid line valve.
- Pump all of the existing HCFC-22 refrigerant back into the outdoor unit. (It may be necessary to bypass the low pressure switches to ensure complete refrigerant evacuation.)
- When the low side system pressures reach 0 psig, close the vapor line valve.
- Disconnect all power to the existing outdoor unit. Check gauges after shutdown to confirm that the valves are not allowing refrigerant to flow back into the low side of the system.
- Disconnect the liquid and vapor lines from the existing outdoor unit.

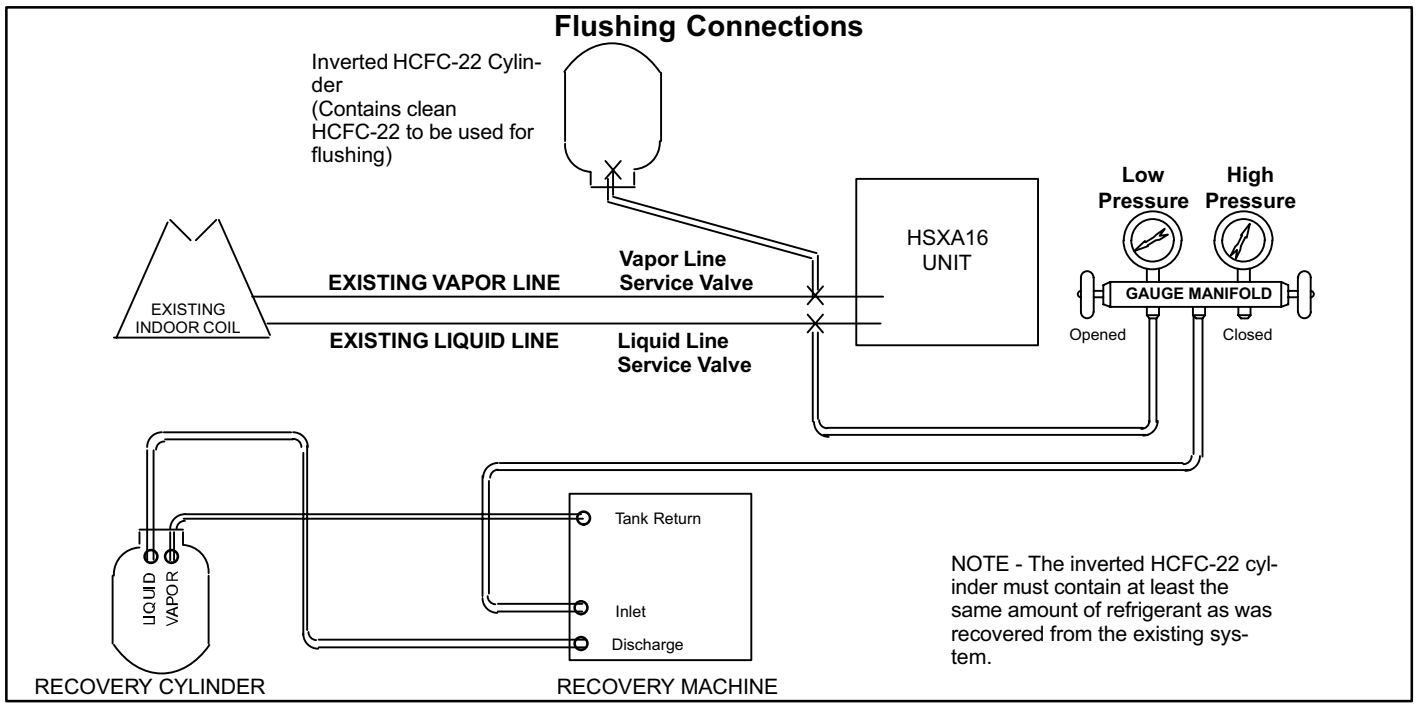

Figure 10

2. Remove the existing outdoor unit. Set the new HFC-410A unit and follow the brazing connection procedure which begins on the previous page to make line set connections. **DO NOT install metering device at this time.** Make low voltage and line voltage connections to the new outdoor unit. **DO NOT turn on power to the unit or open the outdoor unit service valves at this time.**
3. Remove the existing refrigerant flow control orifice or thermostatic expansion valve before continuing with flushing procedures. The existing devices are not approved for use with HFC-410A refrigerant and may prevent proper flushing. Use a field-provided fitting to reconnect the lines.

⚠ IMPORTANT

The line set and indoor coil must be flushed with at least the same amount of clean refrigerant that previously charged the system. Check the charge in the flushing cylinder before proceeding.

4. Remove the pressure tap valve cores from the HSXA16 unit's service valves. Connect an HCFC-22 cylinder with clean refrigerant to the vapor service valve. Connect the HCFC-22 gauge set to the liquid line valve and connect a recovery machine with an empty recovery tank to the gauge set.
5. Set the recovery machine for liquid recovery and start the recovery machine. Open the gauge set valves to allow the recovery machine to pull a vacuum on the existing system line set and indoor coil.
6. Invert the cylinder of clean HCFC-22 and open its valve to allow liquid refrigerant to flow into the system

through the vapor line valve. Allow the refrigerant to pass from the cylinder and through the line set and the indoor coil before it enters the recovery machine.

7. After all of the liquid refrigerant has been recovered, switch the recovery machine to vapor recovery so that all of the HCFC-22 vapor is recovered. Allow the recovery machine to pull a vacuum on the system.

*NOTE - A single system flush should remove all of the mineral oil from the existing refrigerant lines and indoor coil. A second flushing may be done (using clean refrigerant) if insufficient amounts of mineral oil were removed during the first flush. **Each time the system is flushed, you must allow the recovery machine to pull a vacuum on the system at the end of the procedure.***

8. Close the valve on the inverted HCFC-22 drum and the gauge set valves. Pump the remaining refrigerant out of the recovery machine and turn the machine off.
9. Use dry nitrogen to break the vacuum on the refrigerant lines and indoor coil before removing the recovery machine, gauges and HCFC-22 refrigerant drum. Re-install pressure tap valve cores into HSXA16 service valves.
10. Install the field-provided expansion valve (approved for use with HFC-410A refrigerant) in the liquid line at the indoor coil.

Manifold Gauge Set

Manifold gauge sets used with systems charged with HFC-410A refrigerant must be capable of handling the higher system operating pressures. The gauges should be rated for use with pressures of 0 - 800 on the high side and a low side of 30" vacuum to 250 psi with dampened speed to 500 psi. Gauge hoses must be rated for use at up to 800 psi of pressure with a 4000 psi burst rating.

Service Valves

The liquid line and vapor line service valves and gauge ports are used for leak testing, evacuating, charging and checking charge. Each valve is equipped with a service port which has a factory-installed Schrader valve. A service port cap protects the Schrader valve from contamination and serves as the primary leak seal.

Front-Seated Service Valve (Liquid Line)

The front-seated service valve is shown in figure 11. When this valve is closed, the service port is open to the line set. Access the service port and open and close valves as described in the following paragraphs.

To Access Schrader Port:

1. Remove access panel.
2. Remove service port cap with an adjustable wrench.
3. Connect gauge to the service port.
4. When testing is completed, replace service port cap. Tighten finger tight; then torque per table 1 (Page 2).

To Open Front-Seated Service Valves:

1. Remove stem cap with an adjustable wrench.
2. Use a service wrench with a hex-head extension (3/16" for liquid-line valve sizes; 5/16" for vapor-line valve sizes) to back the stem out counterclockwise as far as it will go.
3. Replace the stem cap. Tighten finger tight; then torque per table 1 (Page 2).

To Close Front-Seated Service Valves:

1. Remove the stem cap with an adjustable wrench.
2. Use a service wrench with a hex-head extension (3/16" for liquid-line valve sizes; 5/16" for vapor-line valve sizes) to turn the stem clockwise to seat the valve. Tighten it firmly.
3. Replace the stem cap. Tighten finger tight; then torque per table 1 (Page 2).

Vapor Line Ball Valve

Ball-type service valves (see figure 12) function the same way as the other valves but cannot be rebuilt; if one fails, replace with a new valve. The ball valve is equipped with a service port with a factory-installed Schrader valve. A service port cap protects the Schrader valve from contamination and assures a leak-free seal.

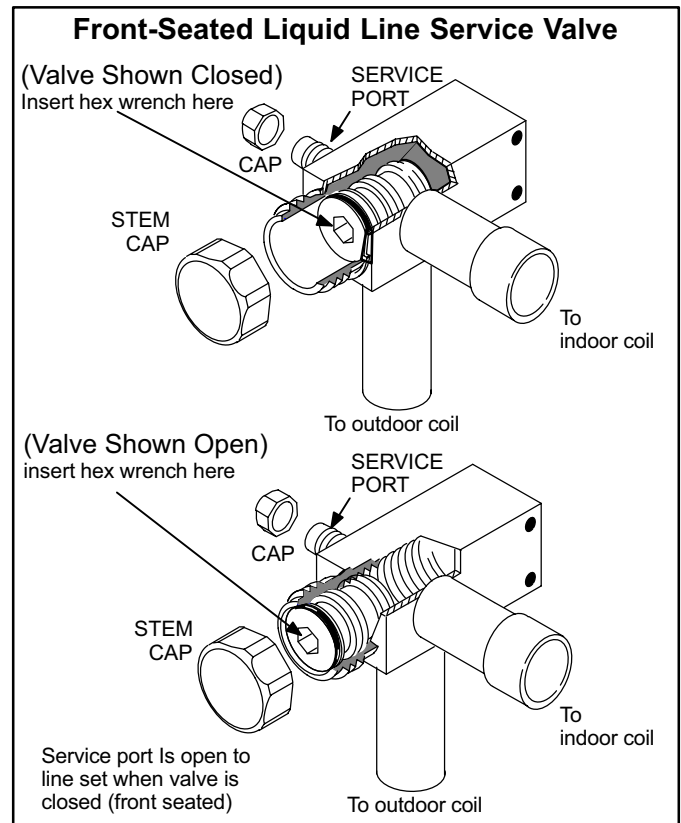

Figure 11

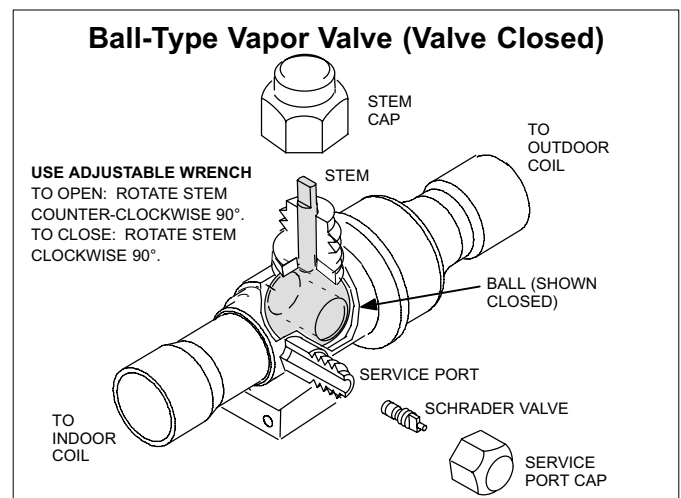

Figure 12

Leak Testing

After the line set has been connected to the indoor and outdoor units, the line set connections and indoor unit must be checked for leaks.

WARNING

Refrigerant can be harmful if it is inhaled. Refrigerant must be used and recovered responsibly.

Failure to follow this warning may result in personal injury or death.

WARNING



Fire, Explosion and Personal Safety Hazard.

Failure to follow this warning could result in damage, personal injury or death.

Never use oxygen to pressurize or purge refrigeration lines. Oxygen, when exposed to a spark or open flame, can cause damage by fire and/or an explosion, that could result in personal injury or death.

WARNING



When using a high pressure gas such as dry nitrogen to pressurize a refrigeration or air conditioning system, use a regulator that can control the pressure down to 1 or 2 psig (6.9 to 13.8 kPa).

Using an Electronic Leak Detector

1. Connect the high pressure hose of the manifold gauge set to the vapor valve service port. (*Normally, the high pressure hose is connected to the liquid line port, however, connecting it to the vapor port helps to protect the manifold gauge set from damage caused by high pressure.*)
2. With both manifold valves closed, connect the cylinder of HFC-410A refrigerant. Open the valve on the HFC-410A cylinder (vapor only).
3. Open the high pressure side of the manifold to allow HFC-410A into the line set and indoor unit. Weigh in a trace amount of HFC-410A. [A trace amount is a maximum of 2 ounces (57 g) refrigerant or 3 pounds (31 kPa) pressure.] Close the valve on the HFC-410A cylinder and the valve on the high pressure side of the manifold gauge set. Disconnect HFC-410A cylinder.
4. Connect a cylinder of dry nitrogen with a pressure regulating valve to the center port of the manifold gauge set.
5. Adjust dry nitrogen pressure to 150 psig (1034 kPa). Open the valve on the high side of the manifold gauge

set in order to pressurize the line set and the indoor coil.

6. After a few minutes, open a refrigerant port to check that an adequate amount of refrigerant has been added for detection (refrigerant requirements will vary with line lengths). Check all joints for leaks. Purge dry nitrogen and HFC-410A mixture. Correct any leaks and re-check.

IMPORTANT

Leak detector must be capable of sensing HFC refrigerant.

Evacuation

Evacuating the system of noncondensables is critical for proper operation of the unit. Noncondensables are defined as any gas that will not condense under temperatures and pressures present during operation of an air conditioning system. Noncondensables and water vapor combine with refrigerant to produce substances that corrode copper piping and compressor parts.

IMPORTANT

Use a thermocouple or thermistor electronic vacuum gauge that is calibrated in microns. Use an instrument that reads from 50 microns to at least 23,000 microns.

1. Connect manifold gauge set to the service valve ports:
 - low pressure gauge to *vapor* line service valve
 - high pressure gauge to *liquid* line service valve
2. Close manifold gauge set valves. Connect the center manifold hose to an upright cylinder of HFC-410A .
3. Connect micron gauge.
4. Connect the vacuum pump (with vacuum gauge) to the center port of the manifold gauge set.
5. Open both manifold valves and start the vacuum pump.
6. Evacuate the line set and indoor unit to an **absolute pressure** of 23,000 microns (29.01 inches of mercury). During the early stages of evacuation, it is desirable to close the manifold gauge valve at least once to determine if there is a rapid rise in **absolute pressure**. A rapid rise in pressure indicates a relatively large leak. If this occurs, repeat the leak testing procedure.
*NOTE - The term **absolute pressure** means the total actual pressure within a given volume or system, above the absolute zero of pressure. Absolute pressure in a vacuum is equal to atmospheric pressure minus vacuum pressure.*
7. When the absolute pressure reaches 23,000 microns (29.01 inches of mercury), close the manifold gauge valves, turn off the vacuum pump and disconnect the manifold gauge center port hose from vacuum pump. Attach the manifold center port hose to a dry nitrogen cylinder with pressure regulator set to 150 psig (1034 kPa) and purge the hose. Open the manifold gauge valves to break the vacuum in the line set and indoor unit. Close the manifold gauge valves.

WARNING

Danger of Equipment Damage. Avoid deep vacuum operation. Do not use compressors to evacuate a system. Extremely low vacuums can cause internal arcing and compressor failure. Damage caused by deep vacuum operation will void warranty.

8. Shut off the dry nitrogen cylinder and remove the manifold gauge hose from the cylinder. Open the manifold gauge valves to release the dry nitrogen from the line set and indoor unit.
9. Reconnect the manifold gauge to the vacuum pump, turn the pump on, and continue to evacuate the line set and indoor unit until the absolute pressure does not rise above 500 microns (29.9 inches of mercury) within a 20-minute period after shutting off the vacuum pump and closing the manifold gauge valves.
10. When the absolute pressure requirement above has been met, disconnect the manifold hose from the vacuum pump and connect it to an upright cylinder of HFC-410A refrigerant. Open the manifold gauge valves to break the vacuum from 1 to 2 psig positive pressure in the line set and indoor unit. Close manifold gauge valves and shut off the HFC-410A cylinder and remove the manifold gauge set.

Start-Up

1. Rotate fan to check for frozen bearings or binding.
2. Inspect all factory- and field-installed wiring for loose connections.
3. After evacuation is complete, open the liquid line and vapor line service valves to release the refrigerant charge (contained in outdoor unit) into the system.
4. Replace the stem caps and secure finger tight, then tighten an additional one-sixth (1/6) of a turn.
5. Check voltage supply at the disconnect switch. The voltage must be within the range listed on the unit's nameplate. If not, do not start the equipment until you have consulted the power company and the voltage condition has been corrected.
6. Set the thermostat for a high stage cooling demand (Y1 and Y2 demand). Turn on power to the indoor blower and close the outdoor unit disconnect switch to start the unit.
7. Recheck voltage while the unit is running. Power must be within range shown on the nameplate.

Refrigerant Charging

IMPORTANT

Some HFC-410A cylinders are equipped with a dip tube which allows you to draw liquid refrigerant from the bottom of the cylinder without turning the cylinder upside-down. The cylinder will be marked if it is equipped with a dip tube.

This system is charged with HFC-410A refrigerant which operates at much higher pressures than HCFC-22. This unit is NOT approved for use with coils which include metering orifices or capillary tubes.

Factory Charge

Units are factory charged with the amount of HFC-410A refrigerant indicated on the unit rating plate. This charge is based on a matching indoor coil and outdoor coil with 15 feet (4.6 m) line set. For varying lengths of line set, refer to table 3 for refrigerant charge adjustment.

Table 3

Refrigerant Charge per Line Set Lengths	
Liquid Line Set Diameter	Ounces per 5 feet (grams per 1.52 meter) adjust from 15 ft. (4.57m) line set*
3/8 in. (9.5mm)	3 ounces per 5 feet (85 grams per 1.52 meter)
*Add the amount shown if line length is greater than 15' (4.57m), subtract the amount shown if less than 15'.	

Units Delivered Void of Charge

IMPORTANT

Mineral oils are not compatible with HFC-410A. If oil must be added, it must be a polyol ester oil. The compressor is charged with sufficient polyol ester oil for approved line set lengths.

If the system is void of refrigerant, clean the system using the following procedure:

1. Use dry nitrogen to pressurize the system and check for leaks. Repair leaks, if possible.
2. Evacuate the system to remove as much of the moisture as possible (triple evacuation).
3. Evacuate the system again. Then, weigh the appropriate amount of HFC-410A refrigerant (listed on unit nameplate) into the system.
4. Start the unit and monitor the system to determine the amount of moisture remaining in the oil. Use test kit 10N46 to verify that the moisture content is within the kit's dry color range.
5. If the moisture content is not within the dry color range, add a new filter drier between the liquid valve and the TXV. You may have to add a new filter drier several times to achieve the required level of dryness.
If system dryness is not verified, the compressor will fail in the future.

Checking Charge

The outdoor unit should be charged during warm weather. However, applications arise in which charging must occur in the colder months. *The method of charging is determined by the outdoor ambient temperature.*

Measure the liquid line temperature and the outdoor ambient temperature as outlined below:

1. Connect the manifold gauge set to the service valves:
 - low pressure gauge to *vapor* valve service port
 - high pressure gauge to *liquid* valve service port
2. Connect the center manifold hose to an upright cylinder of HFC-410A. Close manifold gauge set valves.

- Set the room thermostat to call for heat. This will create the necessary load for properly charging the system in the cooling cycle.
- Use a digital thermometer to record the outdoor ambient temperature.
- When the heating demand has been satisfied, switch the thermostat to cooling mode with a set point of 68°F (20°C). When pressures have stabilized, use a digital thermometer to record the liquid line temperature.
- The outdoor temperature will determine which charging method to use. Proceed with the appropriate charging procedure.

Charge Using the Weigh-in Method – Outdoor Temperature ≤ 65°F (18°C)

If the system is void of refrigerant, or if the outdoor ambient temperature is cool, the refrigerant charge should be weighed into the unit. Do this after any leaks have been repaired.

- Recover the refrigerant from the unit.
- Conduct a leak check, then evacuate as previously outlined.
- Weigh in the unit nameplate charge.

If weighing facilities are not available or if you are charging the unit during warm weather, follow one of the other procedures outlined below.

Charge Using the Approach Method – Outdoor Temperature ≥ 65°F (18°C)

The following procedure is intended as a general guide and is for use on expansion valve systems only. For best results, indoor temperature should be 70°F (21°C) to 80°F (26°C). Monitor system pressures while charging.

- Record outdoor ambient temperature using a digital thermometer.
- Attach high pressure gauge set and operate unit for several minutes to allow system pressures to stabilize.
- Compare stabilized pressures with those provided in table 5, “Normal Operating Pressures.” Minor variations in these pressures may be expected due to differences in installations. Significant differences could mean that the system is not properly charged or that a problem exists with some component in the system. Pressures higher than those listed indicate that the system is overcharged. Pressures lower than those listed indicate that the system is undercharged. A temperature/pressure chart for HFC-410A refrigerant is provided in table 5 for your convenience. Verify adjusted charge using the approach method.
- Use the same digital thermometer you used to check the outdoor ambient temperature to check the liquid line temperature.
- The difference between the ambient and liquid temperatures should match values given in table 4. If the values don’t agree with the those in table 4, add refrigerant to lower the approach temperature, or recover

refrigerant from the system to increase the approach temperature. Be aware of the HFC-410A refrigerant cylinder. It will be light maroon-colored. Refrigerant should be added through the vapor valve in the liquid state.

Table 4
Approach Values

Model No.	Approach Temperature Liquid Line - Outdoor Ambient °F (°C)
HSXA16-024	1.9 + 1 (1 + .5)
HSXA16-036	6.2 + 1 (3.5 + .5)
HSXA16-048	6.0 ± 1 (3.3 ± .5)
HSXA16-060	10.0 ± 1 (5.6 ± .5)

NOTE - For best results, the same electronic thermometer should be used to check both outdoor ambient and liquid line temperatures.

IMPORTANT

Use table 5 to perform maintenance checks. Table 5 is not a procedure for charging the system. Minor variations in these pressures may be due to differences in installations. Significant deviations could mean that the system is not properly charged or that a problem exists with some component in the system.

Table 5

Normal Operating Pressures In psig (Liquid +/- 10 and vapor +/- 5 PSIG)*

Temp. of air entering outdoor coil °F (°C)	-024		-036		-048		-060	
	Liq-uid	Suc-tion	Liq-uid	Suc-tion	Liq-uid	Suc-tion	Liq-uid	Suc-tion
First Stage (Low Capacity)								
65 (18.3)	215	144	224	135	216	138	233	143
75 (23.9)	248	146	258	139	249	140	270	145
85 (29.4)	288	148	300	143	288	143	312	147
95 (35.0)	331	150	342	147	332	145	358	147
105 (40.6)	380	152	395	148	380	147	407	149
115 (46.1)	432	155	451	149	430	150	456	150
Second Stage (High Capacity)								
65 (18.3)	222	142	233	131	226	132	251	127
75 (23.9)	258	144	266	134	261	135	291	135
85 (29.4)	300	146	306	137	301	137	334	141
95 (35.0)	343	148	361	141	347	140	375	142
105 (40.6)	394	150	401	142	395	142	434	146
115 (46.1)	446	153	455	144	448	145	487	149

**These are typical pressures only. Indoor indoor match up, indoor air quality, and indoor load will cause the pressures to vary.*

Charge Using the Subcooling Method – Outdoor Temperature ≤ 65°F (18°C)

When the outdoor ambient temperature is below 65°F (18°C), use the subcooling method to charge the unit. Values from (table 6) are used for this procedure.

Table 6

HFC-410A Temperature (°F) - Pressure (Psig)							
°F	Psig	°F	Psig	°F	Psig	°F	Psig
32	100.8	63	178.5	94	290.8	125	445.9
33	102.9	64	181.6	95	295.1	126	451.8
34	105.0	65	184.3	96	299.4	127	457.6
35	107.1	66	187.7	97	303.8	128	463.5
36	109.2	67	190.9	98	308.2	129	469.5
37	111.4	68	194.1	99	312.7	130	475.6
38	113.6	69	197.3	100	317.2	131	481.6
39	115.8	70	200.6	101	321.8	132	487.8
40	118.0	71	203.9	102	326.4	133	494.0
41	120.3	72	207.2	103	331.0	134	500.2
42	122.6	73	210.6	104	335.7	135	506.5
43	125.0	74	214.0	105	340.5	136	512.9
44	127.3	75	217.4	106	345.3	137	519.3
45	129.7	76	220.9	107	350.1	138	525.8
46	132.2	77	224.4	108	355.0	139	532.4
47	134.6	78	228.0	109	360.0	140	539.0
48	137.1	79	231.6	110	365.0	141	545.6
49	139.6	80	235.3	111	370.0	142	552.3
50	142.2	81	239.0	112	375.1	143	559.1
51	144.8	82	242.7	113	380.2	144	565.9
52	147.4	83	246.5	114	385.4	145	572.8
53	150.1	84	250.3	115	390.7	146	579.8
54	152.8	85	254.1	116	396.0	147	586.8
55	155.5	86	258.0	117	401.3	148	593.8
56	158.2	87	262.0	118	406.7	149	601.0
57	161.0	88	266.0	119	412.2	150	608.1
58	163.9	89	270.0	120	417.7	151	615.4
59	166.7	90	274.1	121	423.2	152	622.7
60	169.6	91	278.2	122	428.8	153	630.1
61	172.6	92	282.3	123	434.5	154	637.5
62	175.4	93	286.5	124	440.2	155	645.0

If necessary, restrict air flow through the outdoor coil to achieve pressures in the 325-375 psig (2240-2585 kPa) range. Higher pressures are necessary for checking the charge. Block equal sections of air intake panels and move obstructions sideways until the liquid pressure is in the 325-375 psig (2240-2585 kPa) range. See figure 13.

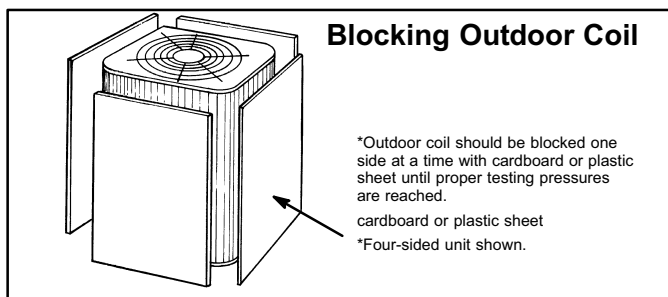

Figure 13

1. With the manifold gauge hose still on the liquid service port and the unit operating stably, use a digital thermometer to record the liquid line temperature.
2. At the same time, record the liquid line pressure reading.
3. Use the temperature/pressure chart (table 6) to determine the saturation temperature for the liquid line pressure reading.
4. Subtract the liquid line temperature from the saturation temperature (according to the chart) to determine subcooling. (**Saturation temperature - Liquid line temperature = Subcooling**)
5. Compare the subcooling value with those in table 7. If subcooling is greater than shown, recover some refrigerant. If subcooling is less than shown, add some refrigerant. Be aware of the HFC-410A refrigerant cylinder. It will be light maroon-colored. Refrigerant should be added through the vapor line valve in the liquid state.

Table 7

Subcooling Values	
Model Number	Second Stage (High Capacity) Saturation Temp. - Liquid Line Temp. °F (°C)
HSXA16-024	10 ± 1 (5.6 ± .5)
HSXA16-036	10 ± 1 (5.6 ± .5)
HSXA16-048	10 ± 1 (5.6 ± .5)
HSXA16-060	7 ± 1 (3.9 ± .5)

System Operation

The outdoor unit and indoor blower cycle on demand from the room thermostat. When the thermostat blower switch is in the **ON** position, the indoor blower operates continuously.

Two-Stage Compressor

The two-stage scroll compressor operates much like the standard scroll compressor. The two-stage compressor steps between low capacity and high capacity as required to meet cooling demand. The steps occur when gas is bypassed through a vent port in the first suction pocket. This bypassing of gas allows the compressor to operate at low capacity if thermostat demand allows, creating a more cost effective and efficient compressor.

Full capacity is achieved by blocking the vent port with a slider ring. The slider ring (vent port cover) is controlled by a **24VDC** internal solenoid in the open position allowing low capacity. When energized the internal solenoid closes the slider ring, blocking the vent port and bringing the compressor to full capacity. Stepping can occur during a single thermostat demand as the motor runs continuously while the compressor steps from low to full capacity.

Filter Drier

A filter drier is factory-installed in each HSXA16 unit to ensure a clean, moisture-free system. A replacement drier is available from Lennox. Refer to Lennox Repair Part Program.

High Pressure Switch

HSXA16 units are equipped with a high pressure switch that is located in the liquid line of the compressor. The switch (SPST, manual reset, normally closed) removes power from the compressor when liquid pressure rises above factory setting at 640 ± 10 psi.

Low Pressure Switch

HSXA16 units are also equipped with a low pressure switch that is located in the vapor line of the compressor. The switch (SPST, auto-reset, normally closed) removes power from the compressor when vapor line pressure drops below factory setting at 40 ± 5 psi.

Maintenance

WARNING



Electric shock hazard. Can cause injury or death. Before attempting to perform any service or maintenance, turn the electrical power to unit OFF at disconnect switch(es). Unit may have multiple power supplies.

Before the start of each heating and cooling season, the following service checks should be performed by a qualified service technician. **First, turn off electrical power to the unit prior to performing unit maintenance.**

- Inspect and clean the outdoor and indoor coils. The outdoor coil may be flushed with a water hose.
NOTE - It may be necessary to flush the outdoor coil more frequently if it is exposed to substances which are corrosive or which block airflow across the coil (e.g., pet urine, cottonwood seeds, etc.)
- Visually inspect the refrigerant lines and coils for leaks.
- Check wiring for loose connections.
- Check voltage at the indoor and outdoor units (with units operating).
- Check the amperage draw at the outdoor fan motor, compressor, and indoor blower motor. Values should be compared with those given on unit nameplate.
- Check, clean (or replace) indoor unit filters.
- Check the refrigerant charge and gauge the system pressures.
- Check the condensate drain line for free and unobstructed flow; clean, if necessary.
- Adjust blower speed for cooling. Measure the pressure drop over the coil to determine the correct blower CFM. Refer to the unit information service manual for pressure drop tables and procedure.
- Check drive belt for wear and proper tension.

NOTE - If owner reports insufficient cooling, the unit should be gauged and refrigerant charge checked. Refer to section on refrigerant charging in this instruction.

NOTE - Outdoor fan motor is prelubricated and sealed. No further lubrication is needed.

Optional Accessories

Refer to the Engineering Handbook for optional accessories that may apply to this unit. The following may or may not apply:

- Loss of charge kit
- High pressure switch kit
- Compressor monitor
- Compressor crankcase heater
- Hail guards
- Mounting bases
- Timed off control
- Stand-off kit
- Sound cover
- Low ambient kit
- Monitor Kit
- *SignatureStat™* room thermostat

Homeowner Information - Maintenance

In order to ensure peak performance, your system must be properly maintained. Clogged filters and blocked airflow prevent your unit from operating at its most efficient level.

1. Ask your Lennox dealer to show you where your indoor unit's filter is located. It will be either at the indoor unit (installed internal or external to the cabinet) or behind a return air grille in the wall or ceiling. Check the filter monthly and clean or replace it as needed.
2. Disposable filters should be replaced with a filter of the same type and size.

NOTE - If you are unsure about the filter required for your system, call your Lennox dealer for assistance.

IMPORTANT

Turn off electrical power to the unit at the disconnect switch before performing any maintenance. The unit may have multiple power supplies.

3. Many indoor units are equipped with reusable foam filters. Clean foam filters with a mild soap and water solution; rinse thoroughly; allow filter to dry completely before it is returned to the unit or grille.
NOTE - The filter and all access panels must be in place any time the unit is in operation.
4. Some systems are equipped with an electronic air cleaner, designed to remove the majority of airborne particles from the air passing through the cleaner. If your system is so equipped, ask your dealer for maintenance instructions.
5. Inspect and clean indoor coil. The indoor evaporator coil is equipped with a drain pan to collect condensate formed as your system removes humidity from the inside air. Have your dealer show you the location of the drain line and how to check for obstructions. (This would also apply to an auxiliary drain, if installed.)

⚠ IMPORTANT

Sprinklers and soaker hoses should not be installed where they could cause prolonged exposure to the outdoor unit by treated water. Prolonged exposure of the unit to treated water (i.e., sprinkler systems, soakers, waste water, etc) will corrode the surface of steel and aluminum parts and diminish performance and longevity of the unit.

6. Inspect and clean outdoor coil:
- Make sure no obstructions restrict airflow to the outdoor unit. Leaves, trash or shrubs crowding the unit cause the outdoor unit to work harder and use more energy. Keep shrubbery trimmed away from the unit and periodically check for debris which collects around the unit.
 - The outdoor coil may require frequent cleaning (depending on environmental conditions). Clean the outdoor coils with an unpressurized water hose to remove surface contaminants and debris.
 - If necessary, clean the outdoor coil more frequently, especially if it is exposed to substances which are corrosive or which block airflow across the coil (ie, pet urine, cottonwood seeds, etc).

Thermostat Operation

Thermostat operations vary from one thermostat to another. The following provides general operation procedures. Refer to the user's information manual provided with your thermostat for specific operation details.

Temperature Setting Levers

Set the lever or dial to the desired temperature setpoints for both heating and cooling. Avoid frequent temperature adjustment; turning the unit off—then back on—before pressures can equalize will put unusual stress on the unit's compressor.

Fan Switch

In AUTO or INT (intermittent) mode, the blower operates only when the thermostat calls for heating or cooling. This mode is generally preferred when humidity control is a priority. The ON or CONT mode provides continuous indoor blower operation, regardless of whether the compressor or furnace is operating. This mode is required when constant air circulation or filtering is desired.

System Switch

Set the system switch for heating, cooling or auto operation. The auto mode allows the system to automatically switch from heating mode to cooling mode to maintain predetermined comfort settings.

Temperature Indicator

The temperature indicator displays the actual room temperature.

Programmable Thermostats

Your Lennox system may be controlled by a programmable thermostat. These thermostats provide the added feature of programmable time-of-day setpoints for both heating and cooling. Refer to the user's information manual provided with your thermostat for detailed programming and operation details.

Preservice Check

If your system fails to operate, check the following before calling for service:

- Make sure all electrical disconnect switches are ON.
- Make sure the room thermostat Temperature Selector and System Switch (Heat, Cool, Auto) are properly set.
- Check for and replace any blown fuses, or reset any tripped circuit breakers.
- Make sure unit access panels are in place.
- Make sure air filter is clean.
- Write down the unit model number and have it handy before calling.

HSXA16 Start-Up & Performance Check List

Job Name _____	Job no. _____	Date _____
Job Location _____	City _____	State _____
Installer _____	City _____	State _____
Unit Model No. _____	Serial No. _____	Service Technician _____
Nameplate Voltage _____	Amps: 1st stage _____	2nd stage _____
Min. Circuit Ampacity _____	Comprsr amps: 1st stage _____	2nd stage _____
Maximum Overcurrent Protection _____		
Electrical Connections Tight? <input type="checkbox"/>	Indoor Filter clean? <input type="checkbox"/>	Supply Voltage (Unit Off) _____
Indoor Blower RPM _____	S.P. Drop Over Indoor (Dry) _____	Outdoor Coil Entering Air Temp. _____
Liquid Pressure 1st stage _____	2nd stage _____	Refrigerant Charge Checked? <input type="checkbox"/>
Vapor Pressure 1st stage _____	2nd stage _____	
Refrigerant Lines: - Leak Checked? <input type="checkbox"/>	Properly Insulated? <input type="checkbox"/>	Outdoor Fan Checked? <input type="checkbox"/>
Service Valves: --- Fully Opened? <input type="checkbox"/>	Caps Tight? <input type="checkbox"/>	Thermostat
Voltage With Compressor Operating _____	Calibrated? <input type="checkbox"/>	Properly Set? <input type="checkbox"/> Level? <input type="checkbox"/>