

Models LRP and LRPR

Roll-in Rack Proofer and Retarder-Proofer

Installation, Service and Parts Manual Rev 1-2022

LBC Bakery Equipment, Inc.

6026 31st Ave NE

Tulalip, WA 98271, USA

Phone: 888-RACKOVN (888-722-5686)

Fax: 425-642-8310

Email: service@lcbakery.com

Website: www.lcbakery.com



Table of Contents

LRP1, LRPR1 Specifications	4
LRP2N, LRPR2N Specifications	5
LRP2S, LRPR2S Specifications.....	6
LRP3, LRPR3 Specifications	7
Refrigeration Condenser Specifications.....	8
Water/Drain Requirements	9
Clearances to adjacent appliances.....	9
Warnings, Cautions, Dangers.....	10
Safety Precautions	12
Assembly Instructions	13
Replacement Parts List.....	14
Schematics, Wiring Diagrams.....	17
Proofer Control Set-up and configurations.....	22
Retarder/Proofer Control Set-up and configurations.....	25
Retarder/Proofer Time Clock Settings	28
Retarder/proofer Automatic Cycle Program Set-up.....	29
Retarder/proofer Automatic Cycle Program Operation	30
Refrigeration Evaporator Positioning, LRPR1	31
Refrigeration Evaporator Positioning, LRPR2N.....	32
Refrigeration Evaporator Positioning, LRPR2S.....	33
Refrigeration Evaporator Positioning, LRPR3	34
Retarder/Proofer Refrigeration Assembly and Wiring	35
Evacuation and Refrigerant Charging	39
Condenser Electrical Connection	39
Evaporator Drain Connection	39
Cooling System Test and Adjustment	40
Limited Warranty	42

THE INFORMATION IN THIS MANUAL IS CRUCIAL AND MUST BE RETAINED FOR FUTURE REFERENCE. READ, UNDERSTAND, AND FOLLOW THE INSTRUCTIONS AND WARNINGS CONTAINED IN THIS MANUAL.

**FOR YOUR SAFETY
DO NOT STORE OR USE GASOLINE OR OTHER FLAMMABLE VAPORS AND LIQUIDS IN THE VICINITY OF THIS OR ANY OTHER APPLIANCE.**

WARNING: IMPROPER INSTALLATION, ADJUSTMENT, ALTERATION, SERVICE OR MAINTENANCE CAN CAUSE PROPERTY DAMAGE, INJURY OR DEATH. READ THE INSTALLATION, OPERATING AND MAINTENANCE INSTRUCTIONS THOROUGHLY BEFORE INSTALLING OR SERVICING THIS EQUIPMENT.

LRP1, LRPR1 Specifications

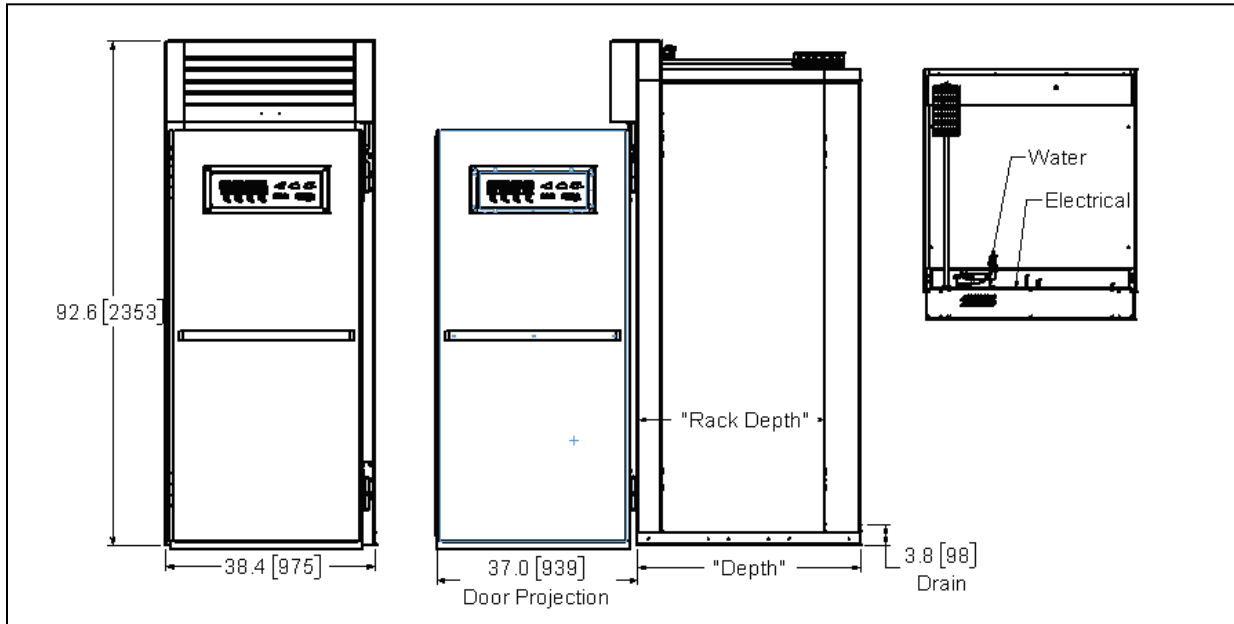

Model	Cooling 208-240 VAC, 1-Ph, 60Hz		Heating 208-240VAC (6.0 kW max)			Retarder BTU @ 35 deg F	Optional Refrigeration Condenser	Rack Depth Inch [CM]	Depth Inch [CM]
	MCA, 1ph	MOP	MCA, 1ph	MCA, 3ph	MOP				
LRP1-40			35	20	50			32.1 [82]	41 [104]
LRPR1-40HO	6.9	15	35	20	50	3000	91500-13	32.1 [82]	41 [104]
LRP1-50			35	20	50			42.1 [107]	51 [130]
LRPR1-50HO	6.9	15	35	20	50	3000	91500-13	42.1 [107]	51 [130]
LRPR1-60HO			35	20	50			52.1 [132]	61 [155]
LRPR1-60HO	7.4	15	35	20	50	4300	91500-14	52.1 [132]	61 [155]
LRP1-70			35	20	50			62.1 [158]	71 [180]
LRPR1-70HO	7.4	15	35	20	50	4300	91500-14	62.1 [158]	71 [180]
LRP1-80			35	20	50			72.1 [183]	81 [206]
LRPR1-80HO	7.4	15	35	20	50	5500	91500-15	72.1 [183]	81 [206]
LRP1-90			35	20	50			82.1 [209]	91 [231]
LRPR1-90HO	7.4	15	35	20	50	5500	91500-15	82.1 [209]	91 [231]
LRP1-100			35	20	50			92.1 [234]	101 [257]
LRPR1-100HO	9.7	20	35	20	50	6000	91500-18	92.1 [234]	101 [257]
LRP1-110			35	20	50			102.1 [259]	111 [282]
LRPR1-110HO	9.7	20	35	20	50	6000	91500-18	102.1 [259]	111 [282]
LRP1-120			35	20	50			112.1 [285]	121 [307]
LRPR1-120HO	12.7	20	35	20	50	8600	91500-01	112.1 [285]	121 [307]

Note: MCA (Minimum Circuit Ampacity), MOP (Maximum Overcurrent Protector).
Allow 107.5" to ceiling when the condensing unit is installed on top of the retarder/proofer.

LRP2N, LRPR2N Specifications

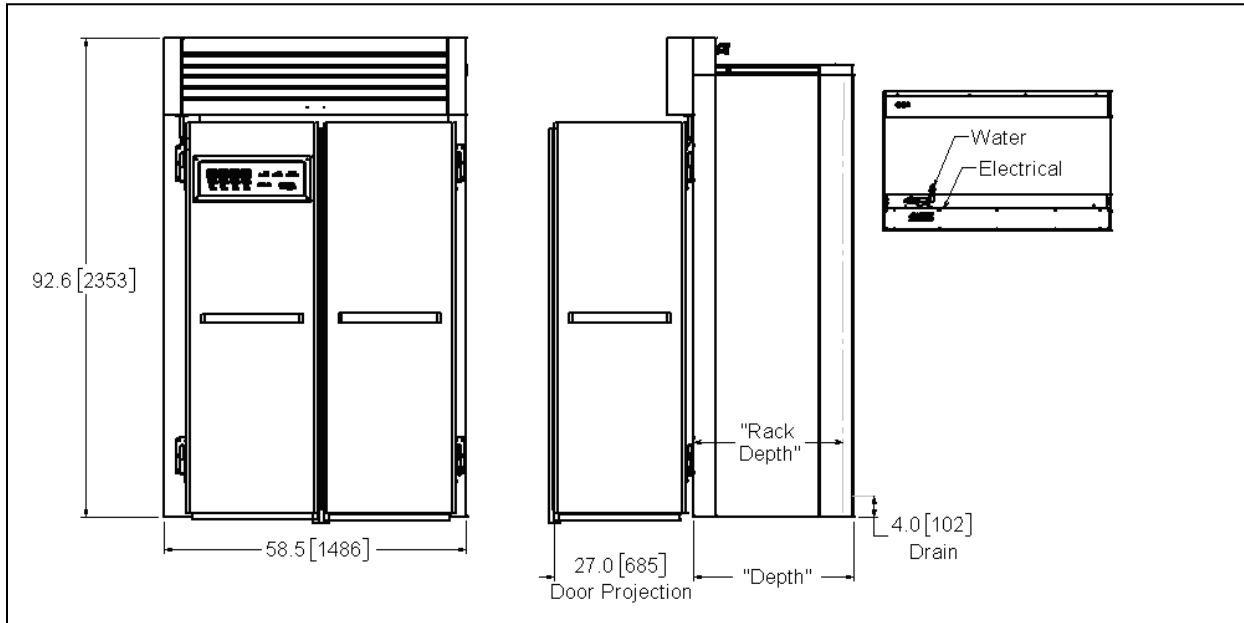

Model	Cooling 208-240 VAC, 1-Ph, 60Hz		Heating 208-240VAC			Retarder BTU @ 35 deg F	Optional Refrigeration Condenser	Rack Depth Inch [CM]	Depth Inch [CM]
	MCA, 1ph	MOP	MCA, 1ph	MCA, 3ph	MOP				
LRP2N-30			35	20	50			29 [74]	31 [79]
LRPR2N-30HO	7.4	15	35	20	50	4300	91500-14	29 [74]	31 [79]
LRP2N-40			35	20	50			39 [99]	41 [104]
LRPR2N-40HO	7.4	15	35	20	50	4300	91500-14	39 [99]	41 [104]
LRP2N-50			35	20	50			49 [124]	51 [130]
LRPR2N-50HO	7.4	15	35	20	50	5500	91500-15	49 [124]	51 [130]
LRP2N-60			35	20	50			59 [150]	61 [155]
LRPR2N-60HO	7.4	15	35	20	50	5500	91500-15	59 [150]	61 [155]
LRP2N-70			35	20	50			69 [175]	71 [180]
LRPR2N-70HO	9.7	20	35	20	50	6000	91500-18	69 [175]	71 [180]
LRP2N-80			35	20	50			79 [201]	81 [206]
LRPR2N-80HO	9.7	20	35	20	50	6000	91500-18	79 [201]	81 [206]
LRP2N-90			35	20	50			89 [226]	91 [231]
LRPR2N-90HO	12.7	20	35	20	50	8600	91500-01	89 [226]	91 [231]
LRP2N-100			35	20	50			99 [251]	101 [257]
LRPR2N-100HO	12.7	20	35	20	50	8600	91500-01	99 [251]	101 [257]
LRP2N-110			n/a	40	60			109 [277]	111 [282]
LRPR2N-110HO	17.2	25	n/a	40	60	11,000	91500-89	109 [277]	111 [282]
LRP2N-120			n/a	40	60			119 [302]	121 [307]
LRPR2N-120HO	17.2	25	n/a	40	60	11,000	91500-89	119 [302]	121 [307]

Note: MCA (Minimum Circuit Ampacity) MOP (Maximum Overcurrent Protector)
 Allow 107.5" to ceiling when the condensing unit is installed on top of the retarder/proofer.

LRP2S, LRPR2S Specifications

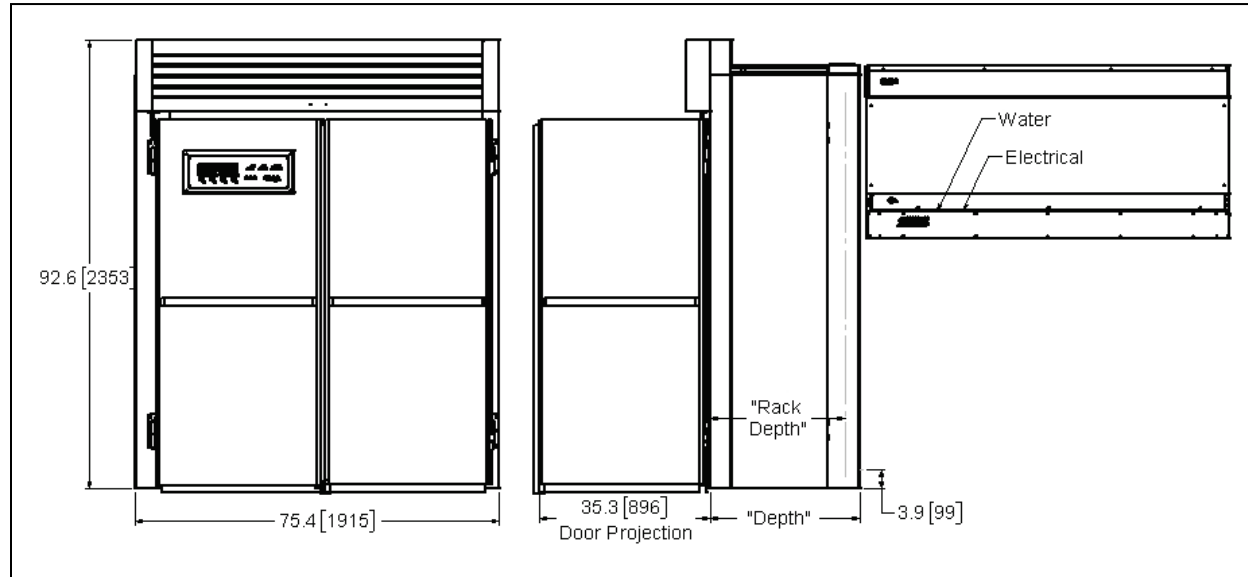

Model	Cooling 208-240 VAC			Heating 208-240 VAC			Retarder BTU @ 35 deg F	Optional Refrigeration Condenser	Rack Depth Inch [CM]	Depth Inch [CM]
	MCA, 1ph	MCA, 3ph	MOP	MCA, 1ph	MCA, 3ph	MOP				
LRP2S-30				35	20	50			29 [74]	31 [79]
LRPR2S-30HO	7.4	n/a	15	35	20	50	5500	91500-15	29 [74]	31 [79]
LRP2S-40				35	20	50			39 [99]	41 [104]
LRPR2S-40HO	7.4	n/a	15	35	20	50	5500	91500-15	39 [99]	41 [104]
LRP2S-50				35	20	50			49 [124]	51 [130]
LRPR2S-50HO	9.7	n/a	15	35	20	50	6000	91500-18	49 [124]	51 [130]
LRP2S-60				35	20	50			59 [150]	61 [155]
LRPR2S-60HO	12.7	n/a	20	35	20	50	8600	91500-01	59 [150]	61 [155]
LRP2S-70				35	20	50			69 [175]	71 [180]
LRPR2S-70HO	12.7	n/a	20	35	20	50	8600	91500-01	69 [175]	71 [180]
LRP2S-80				35	20	50			79 [201]	81 [206]
LRPR2S-80HO	17.2	n/a	25	35	20	50	11000	91500-89	79 [201]	81 [206]
LRP2S-90				n/a	40	60			89 [226]	91 [231]
LRPR2S-90HO	17.2	n/a	25	n/a	40	60	11000	91500-89	89 [226]	91 [231]
LRP2S-100				n/a	40	60			99 [251]	101 [257]
LRPR2S-100HO	22.4	n/a	35	n/a	40	60	15600	91500-86	99 [251]	101 [257]
LRP2S-110				n/a	40	60			109 [277]	111 [282]
LRPR2S-110HO	22.4	n/a	35	n/a	40	60	15600	91500-86	109 [277]	111 [282]
LRP2S-120				n/a	40	60			119 [302]	121 [307]
LRPR2S-120HO	n/a	21.8	30	n/a	40	60	21000	91500-91	119 [302]	121 [307]

Note: MCA (Minimum Circuit Ampacity) MOP (Maximum Overcurrent Protector)
 Allow 107.5" to ceiling when the condensing unit is installed on top of the retarder/proofer.

LRP3, LRPR3 Specifications

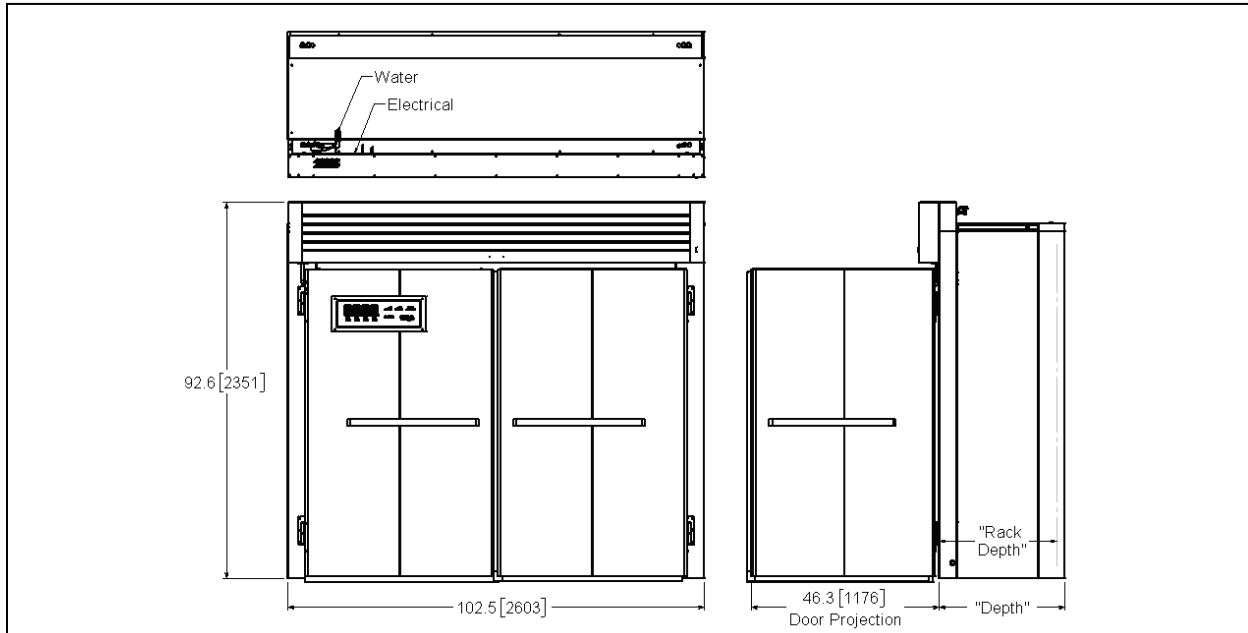

Model	Cooling 208-240 VAC, 60Hz.			Heating 208-240 VAC			Retarder BTU @ 35 deg F	Optional Refrigeration Condenser	Rack Depth Inch [CM]	Depth Inch [CM]
	MCA, 1ph	MCA, 3ph	MOP	MCA, 1ph	MCA, 3ph	MOP				
LRP3-30				35	20	50			29 [74]	31 [79]
LRPR3-30HO	9.7	n/a	15	35	20	50	6000	91500-18	29 [74]	31 [79]
LRP3-40				35	20	50			39 [99]	41 [104]
LRPR3-40HO	12.7	n/a	20	35	20	50	8600	91500-01	39 [99]	41 [104]
LRP3-50				35	20	50			49 [124]	51 [130]
LRPR3-50HO	12.7	n/a	20	35	20	50	8600	91500-01	49 [124]	51 [130]
LRP3-60				35	20	50			59 [150]	61 [155]
LRPR3-60HO	17.2	n/a	25	35	20	50	11000	91500-89	59 [150]	61 [155]
LRP3-70				n/a	40	60			69 [175]	71 [180]
LRPR3-70HO	17.2	n/a	25	n/a	40	60	11000	91500-89	69 [175]	71 [180]
LRP3-80				n/a	40	60			79 [201]	81 [206]
LRPR3-80HO	22.4	n/a	35	n/a	40	60	15600	91500-86	79 [201]	81 [206]
LRP3-90				n/a	40	60			89 [226]	91 [231]
LRPR3-90HO	22.4	n/a	35	n/a	40	60	15600	91500-86	89 [226]	91 [231]
LRP3-100				n/a	40	60			99 [251]	101 [257]
LRPR3-100HO	22.4	n/a	35	n/a	40	60	15600	91500-86	99 [251]	101 [257]
LRP3-110				n/a	40	60			109 [277]	111 [282]
LRPR3-110HO	n/a	21.8	30	n/a	40	60	21000	91500-91	109 [277]	111 [282]
LRP3-120				n/a	40	60			119 [302]	121 [307]
LRPR3-120HO	n/a	21.8	30	n/a	40	60	21000	91500-91	119 [302]	121 [307]

Note: MCA (Minimum Circuit Ampacity) MOP (Maximum Overcurrent Protector)
Allow 107.5" to ceiling when the condensing unit is installed on top of the retarder/proofer.

Refrigeration Condenser Specifications



Condenser Ratings									Evaporator kit Ratings	
Condenser Number	Length Inches [CM]	Width inches [CM]	Height inches [CM]	BTU [Kcal] per hr. @ 25[-4]SST, 95[35] Amb.	Pump-down Charge Capacity, R448A Lbs[kg]	MCA 208-240 VAC	MOP 208-240 VAC	Weight Lbs/kg	For Condenser Kit Number	Rated BTU[Kcal] @ 12 [7] Deg. Evaporator Superheat
91500-13	16.5 [42]	12.5 [32]	11.5 [30]	2460[620]	1.4 [0.682]	6.9, 1p	15	46 [21]	72610-37	3000 [756]
91500-14	15.7 [40]	12.5 [32]	11.5 [30]	4310[1087]	1.4 [0.682]	7.4, 1p	15	48 [22]	72610-38	4300 [1084]
91500-15	18.9 [48]	14.5 [36]	11.5 [30]	5290[1333]	1.4 [0.682]	7.4, 1p	15	71 [32]	72610-39	5500 [1386]
91500-18	24 [61]	16.5 [42]	13 [33]	6430[1621]	3 [1.36]	9.7, 1p	20	85 [39]	72610-40	6000 [1513]
91500-01	24 [61]	16.5 [42]	13 [33]	8960[2263]	5.1[2.32]	12.7, 1p	20	102 [46]	72610-41	8600 [2169]
91500-89	24 [61]	15.8 [47]	16.5 [42]	12,400[3127]	12.7 [5.77]	17.2, 1p	25	130 [59]	72610-42	11,000 [2774]
91500-86	34 [86]	25 [64]	19 [48]	17,800[4489]	11.2 [5.09]	22.4, 1p	35	191 [87]	72610-44	15,600 [3934]
91500-91	34 [86]	25 [64]	19 [48]	26,600[6708]	16.4 [7.45]	21.8, 3p	30	209 [95]	72610-43	21,000 [5295]

Water/Drain Requirements

Water used in this proofer must meet the following requirements for water quality:

Alkalinity < 22 ppm	Magnesium < 0.65 ppm
Aluminum < 17 ppb	pH = 8.5
Calcium < 3.3 ppm	Sodium < 8.5 ppm
Free Chlorine Residual < 0.6 ppm	Total Hardness < 11.9 ppm

If water conditions do not meet the above requirements a water treatment system should be used. High levels of chlorine and dissolved minerals can adversely affect the function of the proofer and may result in deterioration of components.

Water Connections:

All proofers or retarder proofers have at least one water connection point. Larger pass-thru proofers and retarder proofers have a connection at the front and back end of the unit. Water connection points are ½ FNPT, located on top of the unit. Each connection may feed one or two climatizers. Refer to the following table for total waterflow and for total water consumption per hour.

Models	Number of Climatizers	Maximum Consumption in GPM [Lt/min] @ 30 psi [200 kpa]	Maximum Water Flow in GPM [Lt/min] @ 30 psi [200 kpa]	Maximum Water Usage in GPH [Lt/Hr.] @ 30 psi [200 kpa]
LRP1-30 thru LRP1-120	1	0.06 [0.23]	0.5 [1.9]	3.6 [13]
LRP2N-30 thru LRP2N-100	1	0.06 [0.23]	0.5 [1.9]	3.6 [13]
LRP2N-110, LRP2N-120	2	0.12 [0.46]	1.0 [3.8]	7.2 [25]
LRP2S-30 thru LRP2S-80	1	0.06 [0.23]	0.5 [1.9]	3.6 [13]
LRP2S-90 thru LRP2S-120	2	0.12 [0.46]	1.0 [3.8]	7.2 [25]
LRP3-30 thru LRP3-80	1	0.06 [0.23]	0.5 [1.9]	3.6 [13]
LRP3 90 thru LRP3-120	2	0.12 [0.46]	1.0 [3.8]	7.2 [25]

Drain Connections:

Each climatizer has a drain connection which is to be routed out of the proofer and to an airgap drain. Be sure to comply with applicable codes with routing and terminating drain lines. The drain line should be sized to handle the maximum hourly rate of water consumption as shown in the chart above.

Clearances to adjacent appliances

LBC proofers and retarder/proofer are approved for installation with “0” inches clearance to combustible and non-combustible surfaces and for installation on combustible floors. It is not recommended that the proofer or retarder/proofer be installed on a surface that is porous or which can not be easily cleaned and sanitized. An optional stainless-steel floor can be installed over a secure surface. Be sure to seal all edges when installing.

When installing a retarder/proofer next to an oven, be sure to allow a minimum of 4” clearance to reduce the heat transfer from the oven. This will allow the retarder function to cool the box normally.

Warnings, Cautions, Dangers

WARNING MOVING PARTS HAZARD. FOLLOW LOCKOUT PROCEDURES BEFORE REMOVING AIR DUCT OR EVAPORATOR FAN GUARDS

WARNING ELECTRICAL HAZARD BEHIND UPPER FRONT TRIM. FOLLOW LOCKOUT PROCEDURES BEFORE SERVICING.

WARNING THE LBC BAKERY LRP SERIES PROOFER PRODUCES HUMIDITY WHICH WILL NATURALLY CONDENSE AND ACCUMULATE WATER ON THE INTERIOR FLOOR CAUSING IT TO BECOME SLIPPERY. ADJACENT EXTERIOR FLOOR MAY ALSO BECOME SLIPPERY. USE EXTREME CAUTION WHEN WALKING IN OR AROUND THIS APPLIANCE.

NOTICE This picture shows an LRP1, LRP2, and LRP3. The LRP1 and some LRP2 models have only one climitizer. Larger models have two climitzers.

DANGER DO NOT STORE OR USE GASOLINE OR OTHER FLAMMABLE VAPORS OR LIQUIDS IN THE VICINITY OF THIS OR ANY OTHER APPLIANCE.

NOTICE For best results, always allow your proofer to reach set temperature and humidity before putting product in.

NOTICE For best results, proof at lower temperatures rather than higher.

NOTICE To dry proof: Set humidity to the lowest setting (either 45% or less). At this setting the humidity generator is turned off and will not produce humidity.

NOTICE When the actual humidity is less than 46% display will show 45. When the actual humidity is higher than 45%, display will show the actual humidity.

NOTICE Service on this or any other LBC BAKERY equipment must be performed by qualified personnel only. Consult your authorized service agency directory or call the factory at 1-888-722-5686 or go to WWW.LBCBAKERY.COM for the service agent nearest you.

CAUTION THIS APPLIANCE, WHEN INSTALLED, MUST BE ELECTRICALLY GROUNDED IN ACCORDANCE WITH LOCAL CODES, OR IN THE ABSENCE OF LOCAL CODES, WITH THE NATIONAL ELECTRICAL CODE, ANSI/NFPA 70-1996.

CAUTION

FOR INSTALLATION IN CANADA THE INSTALLATION MUST BE IN ACCORDANCE WITH CAN/CGA-B149.1&2 OF THE INSTALLATION CODE, AND LOCAL CODES WHERE APPLICABLE. ALL ELECTRIC WIRING MUST BE IN ACCORDANCE WITH THE CURRENT CANADIAN ELECTRICAL CODE, C22.1 PART 1. GROUNDING THIS APPLIANCE MUST CONFORM TO CANADIAN ELECTRICAL CODE, CSA C22.2.

WARNING

INSTALLATION OF THE UNIT MUST BE DONE BY PERSONNEL QUALIFIED TO WORK WITH ELECTRICITY AND PLUMBING. IMPROPER INSTALLATION CAN CAUSE INJURY TO PERSONNEL AND /OR DAMAGE TO EQUIPMENT. UNIT MUST BE INSTALLED IN ACCORDANCE WITH ALL APPLICABLE CODES

WARNING

MOVING PARTS HAZARD. FOLLOW LOCKOUT PROCEDURES BEFORE REMOVING AIR DUCT OR EVAPORATOR FAN GUARDS

WARNING

ELECTRICAL HAZARD BEHIND UPPER FRONT TRIM. FOLLOW LOCKOUT PROCEDURES BEFORE SERVICING.

WARNING

THE LBC BAKERY LRP SERIES PROOFER PRODUCES HUMIDITY WHICH WILL NATURALLY CONDENSE AND ACCUMULATE WATER ON THE INTERIOR FLOOR CAUSING IT TO BECOME SLIPPERY. ADJACENT EXTERIOR FLOOR MAY ALSO BECOME SLIPPERY. USE EXTREME CAUTION WHEN WALKING IN OR AROUND THIS APPLIANCE.

Safety Precautions

Lockout Procedure

1. Announce lockout to other personnel.
2. Turn both heat and control power off at main panel.
3. Clear unit of all personnel.
4. Test lockout by turning power switch on and observing if control panel displays or fan(s) come on. Check heater circuit with voltmeter.
5. Perform necessary repairs or tests.
6. Clear unit of personnel before restarting.
7. Turn power on at main panel.
8. Announce unit is "on" to other personnel.

Safety Precautions

LBC Bakery Equipment hereby disclaims any and all responsibility for injury, damage, loss or other claim that may occur to person or property from improper alteration, modification, addition, operation, maintenance or service, whether it be mechanical, electrical, fuel, operator, motor or otherwise, which may occur from such improper alteration, modification, addition, operation, maintenance or service to this piece of equipment.

Safety Considerations

Your LBC Bakery LRP Proofer is manufactured to rigid standards. This equipment is E.T.L. listed and meets safety and sanitation standards.

The presence of safety equipment control and interlocks on an appliance and attendant components of installation cannot, in and of themselves, assure absolute safety of operation. Diligent, capable, well trained operators and maintenance personnel, as well as proper programs of operation and maintenance, are essential to the safe and reliable operation of this appliance.

- A. The **responsibility of the manufacturer** is to supply suitable, comprehensive instructions and recommendations for the operation and maintenance of the appliance.
- B. All operations, maintenance and repair of the subject units must be performed by properly trained and qualified personnel, and all such operations, maintenance and repair must be performed in a diligent manner. It is the **responsibility of the owner/operator** to ensure proper training and diligence of any person coming into contact with either the subject units or the output (product, exhaust or otherwise) of the subject units. It is the **responsibility of the owner/operator** to ensure that the subject units are installed and operated in accordance with OSHA Standard 1910.263.
- C. A regular periodic program of cleaning, inspection and maintenance must be established, and comprehensive maintenance records maintained. It is the **sole responsibility of the user** to establish, schedule and enforce the frequency and scope of these programs in keeping with recommended practice and with due consideration given to actual operating conditions.
- D. The appliance must be operated within limits which will not exceed the working limits of any component within the appliance.

Assembly Instructions

- **Installation qualifications:** This appliance must be installed by a qualified installer, approved by LBC Bakery Equipment, Inc. Assembly and installation instructions are provided for both front-load proofers and retarder proofers as well as for pass-thru proofers and retarder proofers. See assembly instructions included with this packet.
- **Stainless Steel Floor Kit:** Some proofers and retarder proofers are provided with an optional stainless-steel floor. Floor panel(s) to be installed with countersinks up. Arrange floor panel(s) to match the physical outer dimensions of the unit being installed. Be sure to seal all edges when installing.
- **Retarder/Proofer Assembly:** Some retarder/proofers are equipped with refrigeration components that require special skills to properly install and charge with refrigerant. Refer to the special refrigeration installations in this manual.
- **Pre-charged Retarder/Proofers:** Some retarder/proofers are provided with optional pre-charged refrigeration components. These components should be installed as part of the assembly of then retarder proofer.
- **Separate Electrical Requirement for Condensers:** In all cases, the condenser unit must be supplied with a separate power supply. The condenser does not connect electrically to the retarder proofer. Refer to the specifications for the model number you are assembling for electrical supply requirements.
- **Remote refrigeration/connection to a refrigeration rack system:** LBC retarder proofers are designed to connect directly to a remote refrigeration condensing system or to a refrigeration rack system. Unless otherwise indicated on the retarder proofer, this appliance must be connected only to remote refrigeration operating on R448A refrigerant.

Replacement Parts List

Climatizer

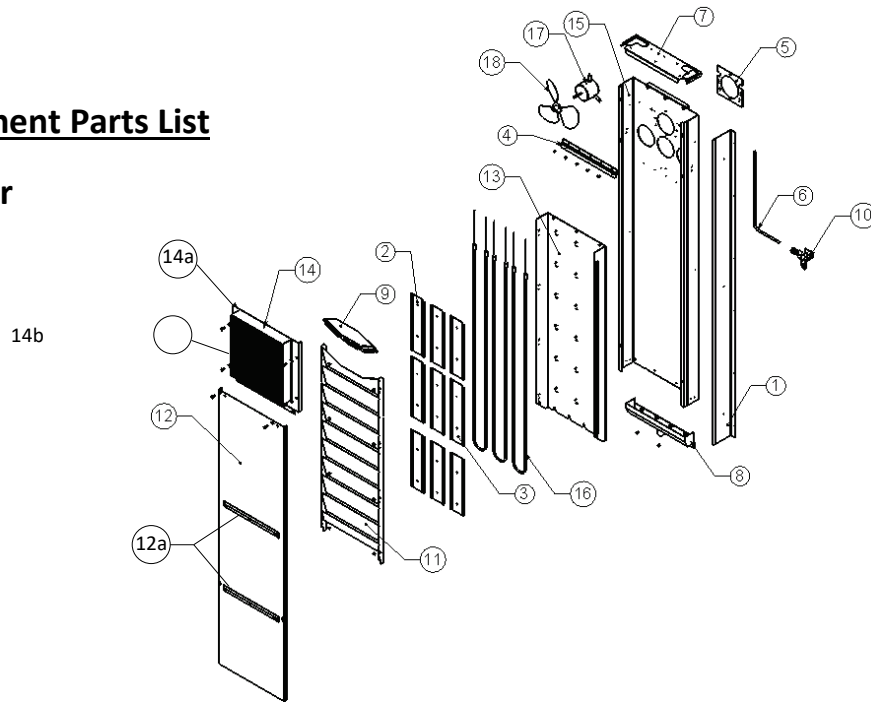

Item	Parts		Description
	Legacy	Current	
1		155-158	Bracket Side - Climatizer
2		155-160-1	Element Clamp top and bottom
3		155-160-2	Element Clamp middle
4		155-161-1	Bottom clamp Bracket
5		155-162-1	Plate, Fan Mount
6		155-167	Copper Tube, 10MM
7	N/A	155-526	Mounting Cleat, Upper – LRP4
8	155-723	155-530	Drip Pan
9	N/A	155-533	Filler Plate Assembly, Spray Deflector
10		155-722	Spray Assembly
*11		** 155-732	Spray Separator
12	155-150	155-802	Element Cover Assembly
12a		71100-12	Bumper
*13	155-161b	155-803	Element Base Assembly
14		155-804	Fan Cover Assembly
14a	155-303		Screen Cover
14b	155-151		Cover Fan
*15	155-162	155-805	Duct Channel Assembly
16		11162-09	Heating Element, 240 VAC, 2200 Watts
17		30200-55	Motor, 220 Volt, 1/15 HP
18		71500-11-1	Fan Impeller

* Special Order | **Requires Item 9.

NOTE: Current design is identifiable by item 7.

Electrical

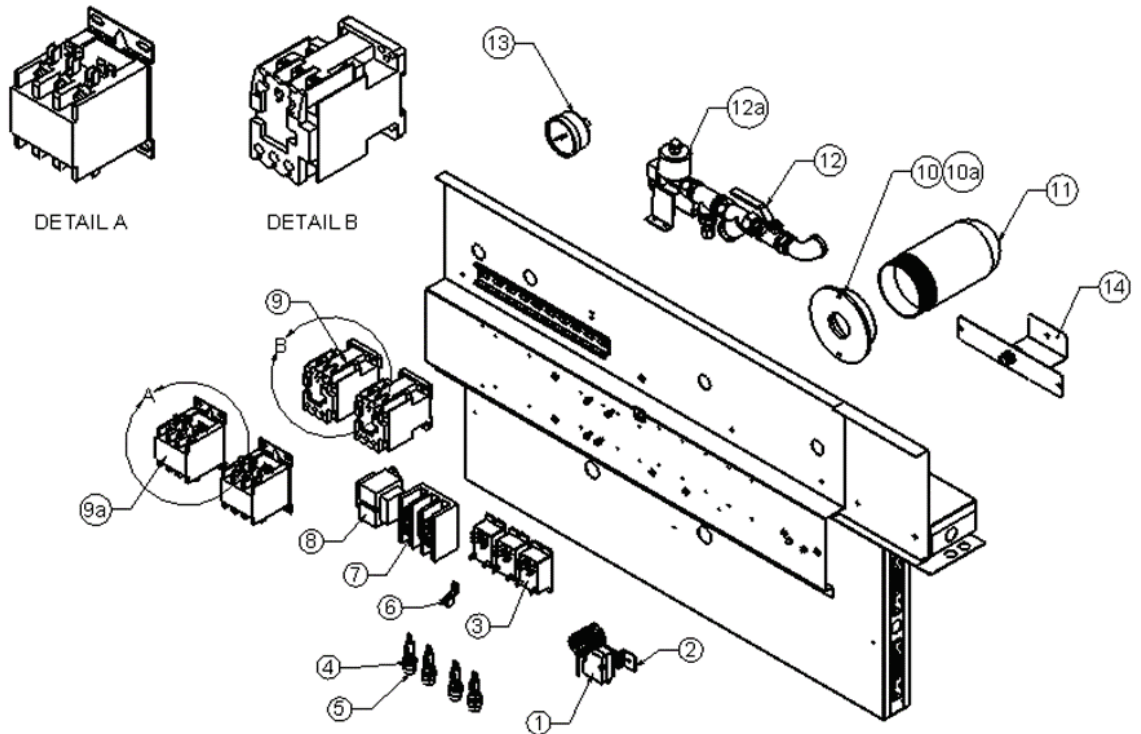

Item	Parts				Description
	LRP1	LRP2N	LRP2S	LRP3	
1		30701-27			High Limit Thermostat, Proofer
2		155-308			Bracket, T-stat Mount
3		30701-05			Relay, 2-pole, 30 Amp – 24 VAC Coil
4		30901-02			Fuse Holder for 15A Fuse
5		30900-01			Fuse 15A (ABC-15)
6		31200-02			GROUNDING LUG
7		30500-07			Terminal Block, 3-Pole, 125 Amp
8		31400-26			XFMR 120/208/240 Primary 12-24 40VA
*9		30700-76			Contactor, 3-Pole, 50A, CU-32R
*9a		30700-17			Contactor, 3-Pole, 50A, M 98
10		31602-06			Lamp Socket Rack Proofer
10a		31603-04-1			250V 50W CFL Light Bulb
11		31602-06-1			Lamp Globe
12		70101-200			Water Connection
12a		70403-01			Solenoid Valve, 24 VAC. 1/4 NPT
13		70404-03			Gauge 0-100 PSI 4X515
14		155-725-3			Hi Limit Bulb Assembly

***NOTE:** Either set of contactors may be present. Replace Item 9 or 9a to its match in likeness.

Doors

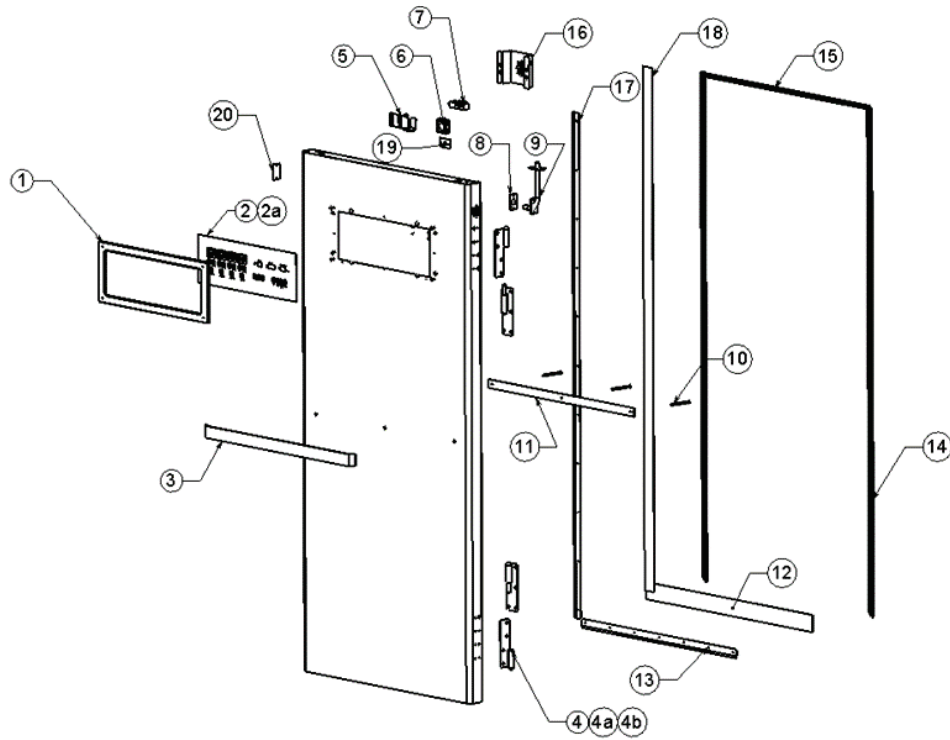

Items	Parts				Description
	LRP1	LRP2N	LRP2S	LRP3	
1	155-330-1	155-330-1	155-330-1	155-330-1	Control Bracket
2	40102-65-1	40102-65-1	40102-65-1	40102-65-1	Proofer Control w/ Timer
2a	40102-63	40102-63	40102-63	40102-63	Retarder/Proofer Control
3	155-702	155-702-17	155-702	155-702-1	Door Handle
4	155-806	N/A	N/A	N/A	Complete Hinge Set LRP1 (1 Req.)
4a	N/A	155-807			Hinge Assembly, Left Door (2 Req.)
4b	N/A	155-808			Hinge Assembly, Right Door (2 Req.)
5	70602-24	70602-24	70602-24	70602-24	Door Closer, Strike
6	30200-42	30200-42	30200-42	30200-42	Fan, Micro-5VDC
7	40106-05	40106-05	40106-05	40106-05	Temp/Humidity Sensor
8	155-338-2	155-338-2	155-338-2	155-338-2	Plate Control Wireway
9	155-672-1	155-672-1	155-672-1	155-672-1	Wire Assembly
10	20109-51	20109-51	20109-51	20109-51	Screw, Door Handle
11	71100-14	71100-19	71100-14	71100-14	Bumper- Door
12	155-114	155-114-17	155-114	155-114-1	Bottom Seal
13	155-128	155-128-17	155-128-24	155-128-1	Bottom Retainer
14	N/A	72602-21-1-L	72602-21-1-L	72602-213-1-L	Door Seal, Left
15	72602-21-2	72602-21-1-R	72602-21-1-R	72602-213-1-R	Door Seal, Right
16	155-410	155-410	155-410	155-410	Bracket, Sensor Guard
17	N/A	155-127	155-127	155-127	Center Retainer
18	N/A	155-131	155-131	155-131	Center Seal
19	155-338-3	155-338-3	155-338-3	155-338-3	Seal Wireway
20	155-338B	155-338B	155-338B	155-338B	Plate, Hole Cover

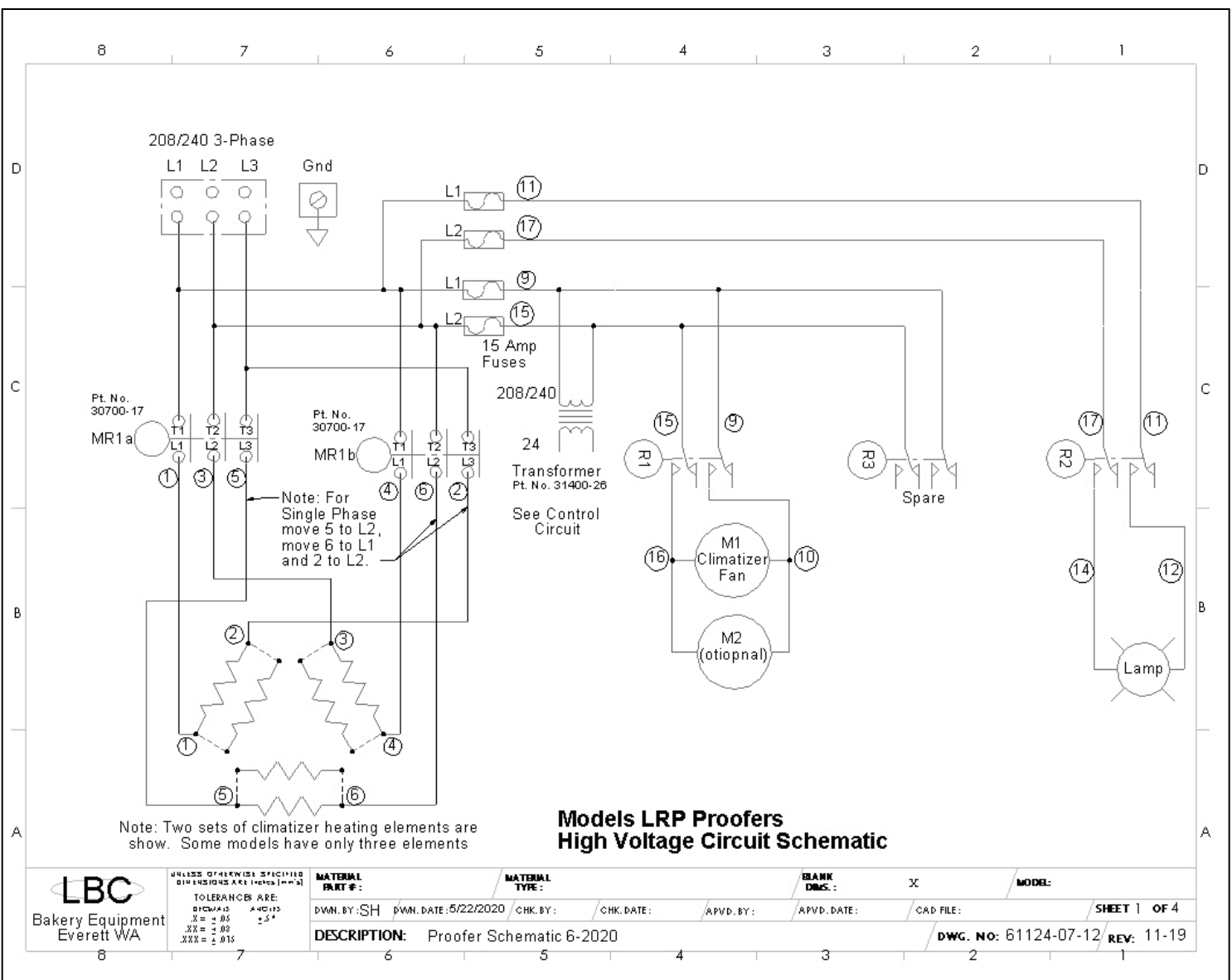

	UNLESS OTHERWISE SPECIFIED DIMENSIONS ARE IN INCHES (PARENS)	MATERIAL PART #:	MATERIAL TYPE:	BLANK DWS:	X	MODEL:	
	TOLERANCES ARE: DIM & D ± .05 XX = ± .02 XXX = ± .015	DWN. BY: SH	DWN. DATE: 5/22/2020	CHK. BY:	CHK. DATE:	APVD. BY:	APVD. DATE:
	DESCRIPTION: Proofer Schematic 6-2020	DWG. NO: 61124-07-12			REV: 11-19		

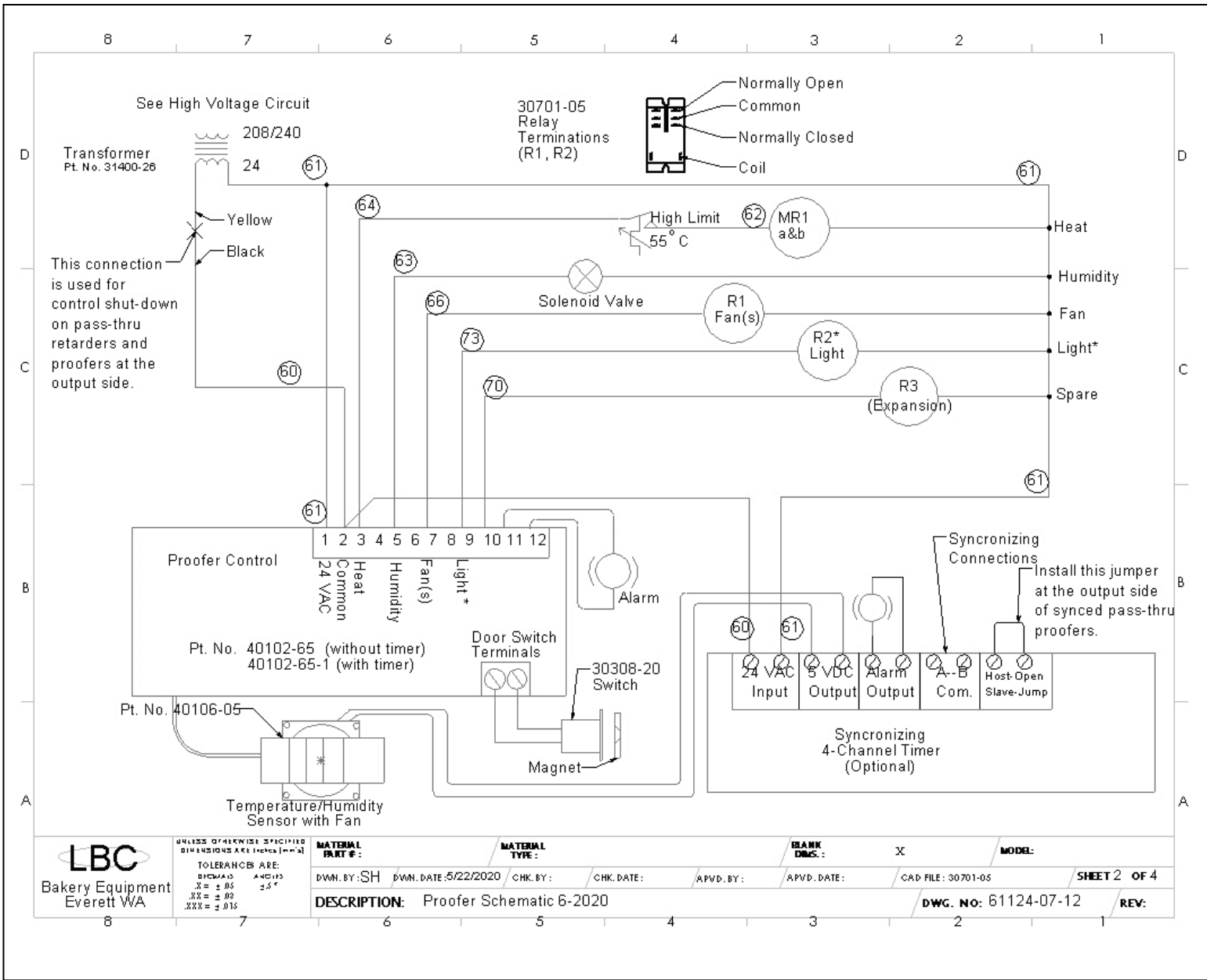

LBC
Bakery Equipment
Everett WA

UNLESS OTHERWISE SPECIFIED
DIMENSIONS ARE IN INCHES (M-M-M)
TOLERANCES ARE:
DIMENSIONS ANGLES
.X = ± .05 ± .5°
.XX = ± .02 ± .5°
.XXX = ± .01

MATERIAL PART #:	MATERIAL TYPE:	BLANK DWS.:	MODEL:
DWN. BY: SH	DWN. DATE: 5/22/2020	CHK. BY:	CHK. DATE:
DESCRIPTION: Proofer Schematic 6-2020		APVD. BY:	APVD. DATE:
		CAD FILE: 30701-05	SHEET 2 OF 4
		DWG. NO: 61124-07-12	REV:

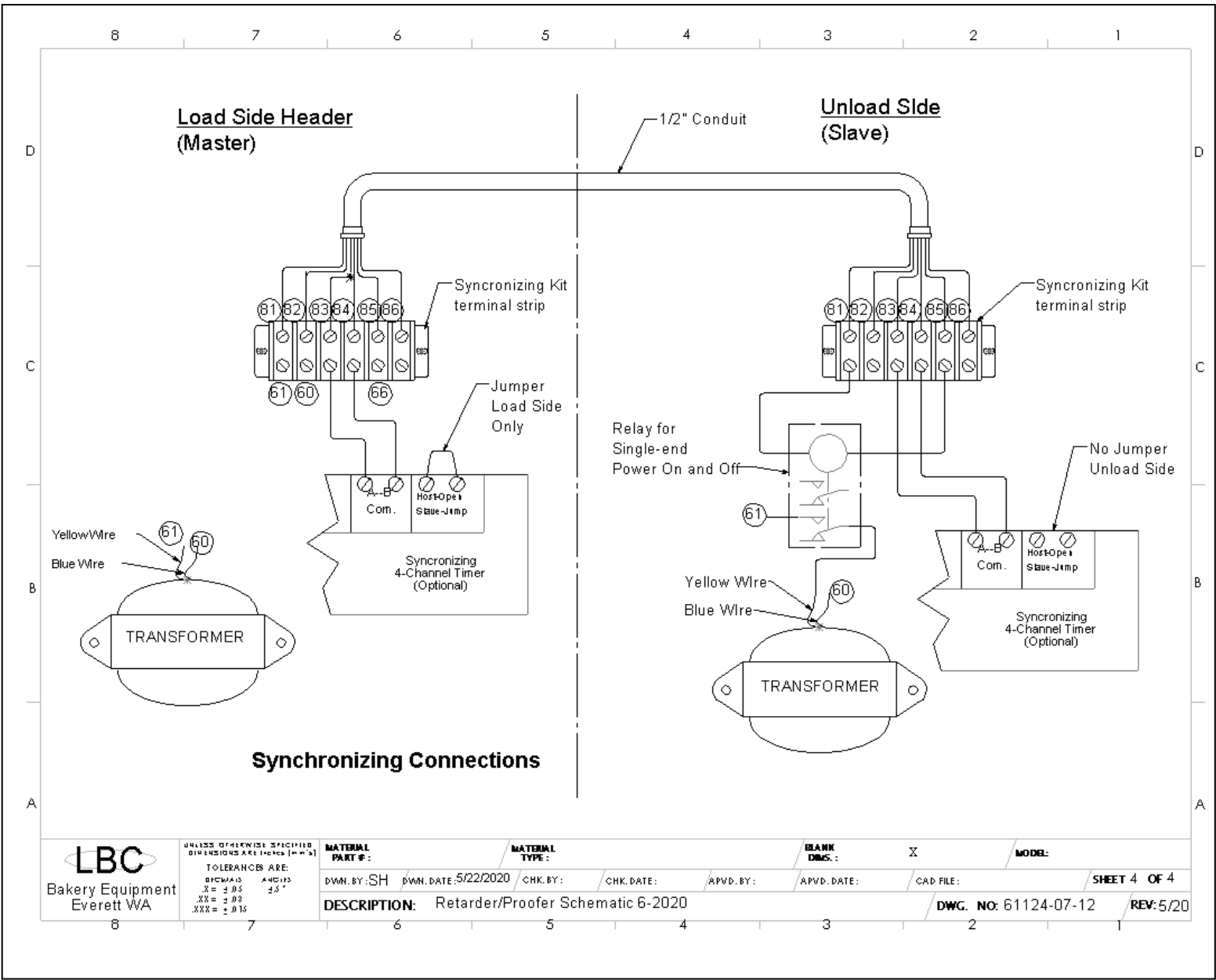

	<small>UNLESS OTHERWISE SPECIFIED DIMENSIONS ARE IN INCHES (IN.)</small> TOLERANCES ARE: DIM & POS ± .05 ANG ± .5° HOLE ± .02 XXX ± .015	MATERIAL PART #: DWN. BY: SH DWN. DATE: 5/22/2020 CHK. BY: CHK. DATE: APVD. BY: APVD. DATE:	MATERIAL TYPE: X	BLANK DWS.: X	MODEL: CAD FILE:
	DESCRIPTION: Retarder/Proofer Schematic 6-2020				
					DWG. NO: 61124-07-12

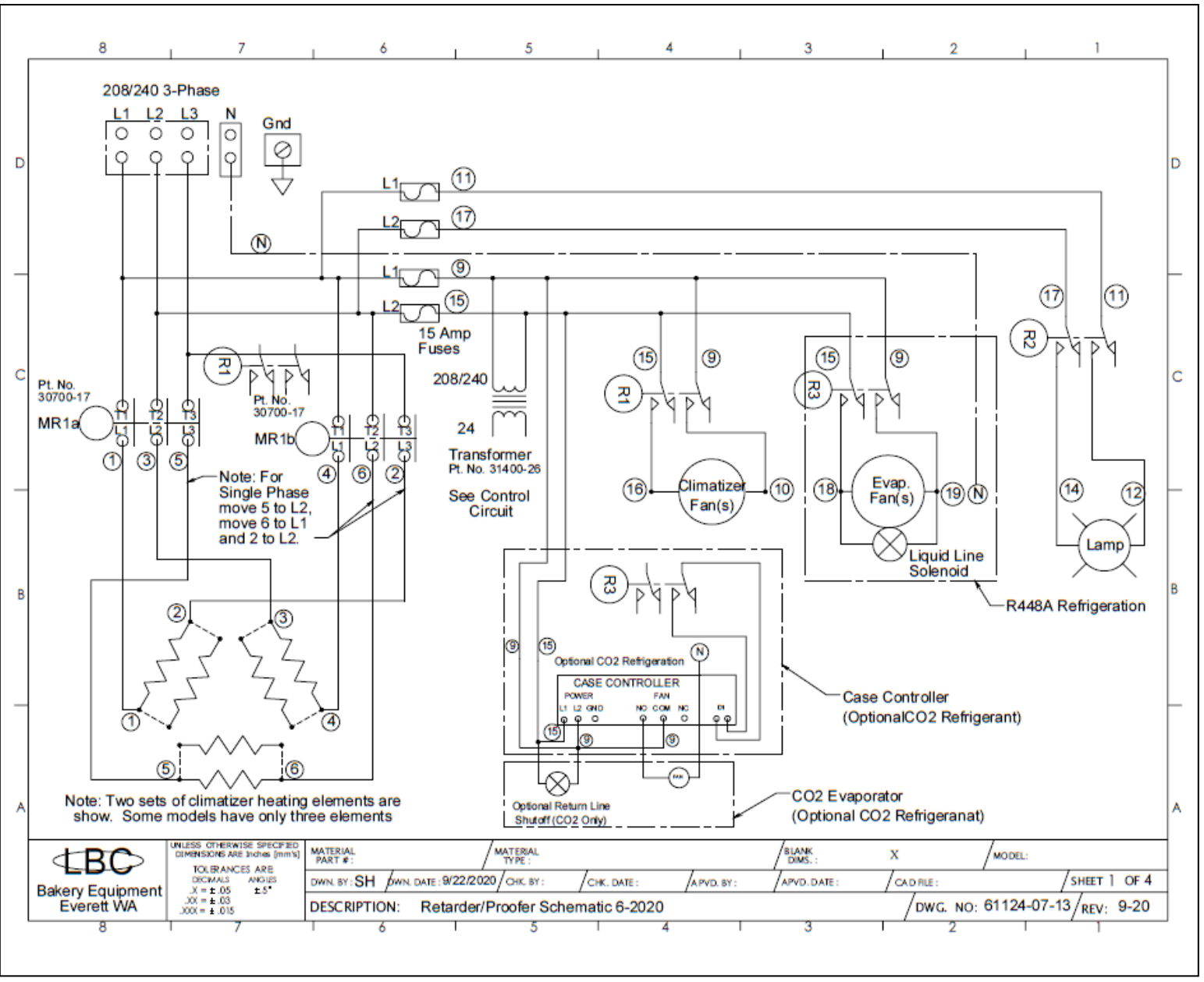

	UNLESS OTHERWISE SPECIFIED DIMENSIONS ARE INCHES (mm)	MATERIAL PART # :	MATERIAL TYPE :	BLANK DIMS. : X	MODEL :				
	TOLERANCES ARE DECIMALS ANGLES .XX = ± .05 ±.5° .XXX = ± .015	DWN. BY: SH	DWN. DATE: 9/22/2020	CHK. BY:	CHK. DATE:	APVD. BY:	APVD. DATE:	CAD FILE:	SHEET 1 OF 4
	DESCRIPTION: Retarder/Proofer Schematic 6-2020						DWG. NO: 61124-07-13	REV: 9-20	

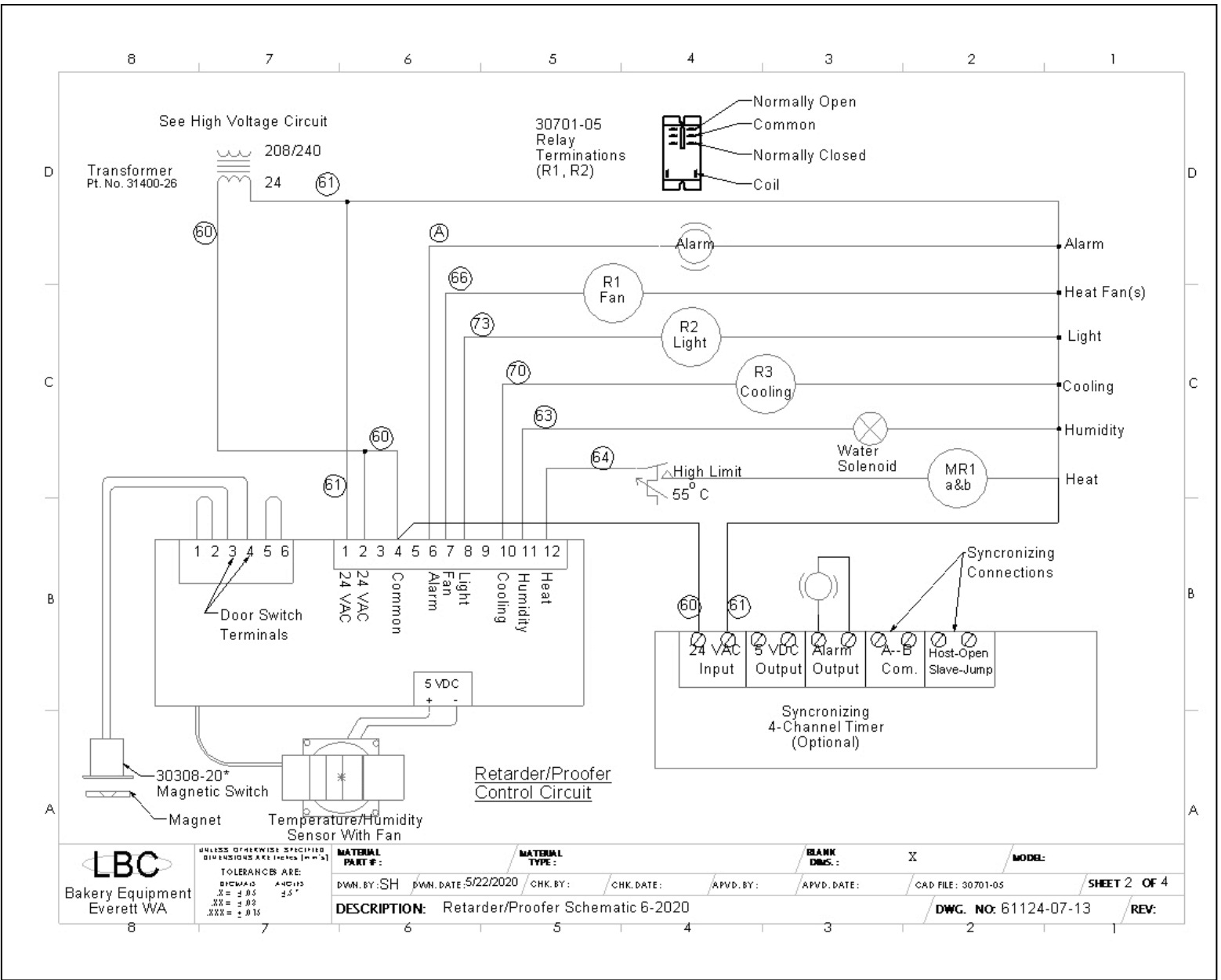

LBC
Bakery Equipment
Everett WA

UNLESS OTHERWISE SPECIFIED
DIMENSIONS ARE IN INCHES (mm)

TOLERANCES ARE:
DIMENSIONS AND FITS
X = ± 0.05 2.5"
XX = ± 0.02
XXX = ± 0.15

MATERIAL PART #:	MATERIAL TYPE:	BANK DWS:	X	MODEL:
DWN. BY: SH	DWN. DATE: 5/22/2020	CHK. BY:	CHK. DATE:	APVD. BY:
DESCRIPTION: Retarder/Proofer Schematic 6-2020			CAD FILE: 30701-05	SHEET 2 OF 4
			DWG. NO: 61124-07-13	REV:

Proofer Control Set-up and configurations

LBC proofers are available in a broad variety of sizes to be used in a variety of applications. Controls are provided that can be configured to maximize performance, minimize energy usage, control water consumption, and reduce wear and tear. This section covers the settings and peripheral components of the control and how to properly configure them.

Proofer Control Functions under 0008 access code:

To access the Proofer function settings 0008:

- 1) Press the POWER button to turn the proofer control off.
- 2) Press the "Up" arrow button and the Down Arrow button' simultaneously until "0000" appears in the temperature and humidity displays.
- 3) Press the Up or Down Arrow button to change the display to "0008".
- 4) Press the Time button to advance through the functions.
- 5) Press the up or down arrows to change the setting.
- 6) Press the Time button to advance to oT.
- 8) Press the POWER button to exit the function settings.
 - **oT:** This setting can be set to cause the control to alarm if it is slow to heat up. This feature is more confusing to operators than helpful and should be set to "00".
 - **rT:** This setting is used to change the displayed temperature by offsetting it up or down. This should be used only when compared to an accurate thermometer. *Example: If the displayed temperature is 90F and an accurate temperature sensing device displays 85, the offset can be decreased by 5 degrees from its current setting. So, if the offset is at -7, decreasing the offset by 5 degrees will result in an offset of -12.*
 - **rA:** This setting is used to change the displayed relative humidity by offsetting it up or down. This should be used only when compared to an accurate hygrometer. *Example: If the displayed relative humidity is 75% and an accurate hygrometer displays 85%, the offset can be increased by 10% from its current setting. So if the offset is at -4, increasing the offset by 10% will result in an offset of +8.*
 - **Td:** This setting will limit how far from the set point the temperature display can vary. It is not recommended to use this at any setting other than "00".
 - **Ad:** This setting will limit how far from the set point the humidity display can vary. It is not recommended to use this at any setting other than "00".

Proofer Control Functions under 0088 access code:

To access the Proofer function settings 0088:

- 1) Press the POWER button to turn the proofer control off.
- 2) Press the “Up” arrow button and the Down Arrow button' simultaneously until "0000" appears in the temperature and humidity displays.
- 3) Press the Up or Down Arrow button to change the display to "0088".
- 4) Press the Time button to advance through the functions.
- 5) Press the up or down arrows to change the setting.
- 6) Press the Time button to advance to TP.
- 8) Press the POWER button to exit the function settings.
 - **TP:** This setting controls the PID function of the heat control. Leave this at “00”.
 - **Tt:** This setting controls the length of the PID cycle. Leave it set to “00”.
 - **Tc:** This setting controls how frequency of the PID cycle. Leave it set to “00”.
 - **Ac:** This setting sets the frequency of the humidity cycle. Set this number to “32”. If the humidity is slow to recover with a load in the proofer, lower this number to “16”.
 - **Ao:** This setting controls how long the humidity output will be on per humidity cycle. “Set it to 04”. If the humidity is overshooting when loaded, lower this to “02”.
 - **oH:** This setting determines how high the humidity can overshoot before the alarm will sound. This feature is more confusing to the operator than it is helpful and should be left at “00”.
 - **dF:** This function is inactive.
 - **FI:** This function is inactive.
 - **oL:** This setting turns on the output alarm for the proofer only and will not affect the timers.
 - **oP:** This setting will determine how long the proofer door can be left open before the proofer automatically shuts off. Setting this to “00” will defeat the automatic shut-off feature. Having the feature turned on will help to extend the life of the proofer.
 - **CL:** This setting will adjust how long the proofer doors can be left closed before the control automatically stops producing humidity. This feature greatly extends the life of the proofer by stopping humidification when the proofer does not have a load.
 - **F2:** This setting limits the maximum settable humidity. Set this to 90%.
 - **To:** This setting determines how high the temperature can be set by the operator. Set this to “105”. *Note: If the proofing temperature is too high, there will be increased condensation in the proofer on the walls and ceiling.*

Proofer control				
Function settings Code 0008				
Function	Short Name	Description	Factory set point	Range
oT	Heat timer alarm	Sounds the alarm if the set temperature is not reached within the indicated number of minutes.	00	0 - 99
rT	Temperature Calibration	Changes the displayed temperature in Degrees F to match that of a calibration thermometer.	00	+25, -25
rA	Humidity Calibration	Changes the displayed relative humidity to match that of a calibration meter.	00	+25, -25
Td	Temperature Lock	Limit the range of temperature variance shown in degrees.	00	0 - 99
Ad	Humidity Display Limit	Limits the range of displayed humidity from the set point. 00 turns this function off.	00	0 - 99
Proofer control				
Function settings Code 0088				
TP	Proportion Factor	Sets the ratio of proportional on time to temperature difference.	07	7
Tt	Heat cycle time	Sets the length of the PID cycle in seconds.	00	00
Tc	Temperature Cycle Rate	This controls how often the temperature proportional output will turn on.	15	15
Ac	Humidity Cycle time	Sets the length of time in seconds for each humidity cycle.	32	16 - 32
Ao	Humidity On time	Sets the "on" time in seconds for humidity in each cycle.	04	0 - 20
oH	Upper Humidity Alarm	This sets the alarm range for humidity overshoot. It should be set to 00 to turn it off.	00	0 - 99
dF	N/A	This function is inactive.	00	00
FI	N/A	Inactive	00	00
oL	Alarm Off/On	Turns alarm output on or off.	01	00 - 01
oP	Open Door Shut-off	Sets how long the door can be open before the proofer turns off. Set to 00 to disable.	10	0.0 - 99
CL	Unattended Humidity Shut-off	Sets how long the proofer can be left unattended (Door Closed) before the humidity turns off.	45	0.0 - 99
F2	Max Set Humidity	Sets how high the user can set the humidity	90	00-99
To	Max Set Temp	Limits the maximum temperature the operator can set.	105	00 - 01.22

Retarder/Proofer Control Set-up and configurations

LBC Retarder/proofer are available in a broad variety of sizes to be used in a variety of applications. Controls are provided that can be configured to maximize performance, minimize energy usage, control water consumption, and reduce wear and tear. This section covers the settings and peripheral components of the control and how to properly configure them.

Retarder/Proofer Control Functions under 0008 access code:

To access the Retarder/Proofer function settings:

- 1) Press the POWER button to turn the retarder control off.
- 2) Press the “Up” arrow button and the Auto/Manual button simultaneously until "0000" appears in the temperature and humidity displays.
- 3) Press the Up or Down Arrow button to change the display to "0008".
- 4) Press the Time button to advance through the functions.
- 5) Press the up or down arrows to change the setting.
- 6) Press the Time button to advance to F1.
- 8) Press the POWER button to exit the function settings.
 - **F1:** This setting is used to change the displayed temperature by offsetting it up or down. This should be used only when compared to an accurate thermometer. *Example: If the displayed temperature is 90F and an accurate temperature sensing device displays 85, the offset can be increased by 5 degrees from its current setting. So, if the offset is at -7, increasing the offset by 5 degrees will result in an offset of -2.*
 - **F2:** This setting is used to change the displayed humidity by offsetting it up or down. This should be used only when compared to an accurate hygrometer. *Example: If the displayed humidity is 90% and an accurate humidity sensing device displays 85%, the offset can be decreased by 5% from its current setting. So, if the offset is at -7, decreasing the offset by 5 degrees will result in an offset of -12.*
 - **F3:** This setting will limit how far from the set point the temperature display can vary. It is not recommended to use this at any setting other than “00”.
 - **F4:** This setting will limit how far from the set point the humidity display can vary. It is not recommended to use this at any setting other than “00”.
 - **F5:** This setting controls the PID function of the heat control. Leave this at “00”.
 - **F6:** This setting controls the length of the PID cycle. Leave it set to “00”.
 - **F7:** This setting controls how frequency of the PID cycle. Leave it set to “00”.
 - **F8:** This setting sets the frequency of the humidity cycle. Set this number to “32”. If the humidity is slow to recover with a load in the proofer, lower this number to “16”.
 - **F9:** This setting controls how long the humidity output will be on per humidity cycle. “Set it to 04”. If the humidity is overshooting when loaded, lower this to “02”.

- **F10:** This setting determines how long the control will wait before starting the refrigeration cycle. This delay is meant to protect the compressor from overheating. This does not need to be greater than “00”.
- **F11:** This setting determines what the dead band is for cooling. Raising this number will increase the difference between cooling on and off. Set this to “2.0”.
- **F12:** This setting changes the heating dead band. Increasing this will increase the fluctuation in temperature. Set this to “0.5”.
- **F13:** Not used.
- **F14:** This setting determines how long the light will be on after the light button is pressed. If this is set to “00”, the interior light will stay on until you turn it off.
- **F15:** This setting determines how long the alarm will sound on the retarder/proofer control only. It will not affect the 4-channel timer alarm. Set this to “0.0”.
- **F16:** This setting determines how long the retarder will be in the defrost mode once it starts. Set this to 30 for best results.
- **F17:** This setting determines how often the retarder/proofer will defrost. Set to “08” for 8 hours and the best results.
- **F18:** This setting can be used to control heated defrost when used. Set this to 32. Electric Heated defrost is not used on retarder/proofer.
- **F19:** This setting determines what temperature the proofer portion of the control can reach before it sounds an alarm. Set this to “140”.
- **F20:** This setting determines how high the user can set the temperature in any mode. Set this to “105” for best results. *Note: If the proofing temperature is too high, there will be increased condensation in the proofer on the walls and ceiling.*
- **F21:** This setting determines the minimum set point of the retard and hold modes. Set this to “32” for best results.
- **F22:** This setting determines the scale of the temperature display. When set to “C”, the display will show the Celsius temperature, followed by “C”.
- **F23:** This setting will adjust how long the retarder/proofer doors can be left closed in “Proof” mode before the control automatically stops producing humidity. This feature greatly extends the life of the retarder/proofer by stopping humidification when there is no product in the retarder/proofer. **If there is no door switch, this must be set to “00”.**
- **F24:** This setting will determine how long the door can be left open in proofing mode before the unit automatically shuts off. Setting this to “00” will defeat the automatic shut-off feature. Having the feature turned on will help to extend the life of the proofer. “10” works best. **If there is no door switch, this must be set to “00”.**
- **F25:** This setting controls the function of the output at Pin 7. For retarder/proofer **built before June of 2020, with 4 or more 24 VAC relays, set this to “0”**. For Retarder/Proofer build June 1 of 2020 with only 3-24 VAC relays, set this to “1”. With this set to “1”, the output at Pin #7 will only be on in the rest or proof mode. This will not work with older units.

Retarder/Proofer control				
Function settings				
Function	Short Name	Description	Factory set point	Range
F1	Temperature Calibration	Increase the value to increase the display and lower the actual temperature.	00	+25, -25
F2	Humidity Calibration	Increase the value to increase the display and lower the actual humidity.	00	+25, -25
F3	Temperature Lock	Limit the range of temperature variance shown in degrees.	00	0 - 9
F4	Humidity Lock	Limit the range of humidity variance shown in degrees.	00	0 - 9
F5	Heat PID range	Sets the range for PID control in degrees.	07	0 - 99
F6	Proportion Factor	Sets the ratio of proportional of on time to temperature difference.	00	0 - 30
F7	Heat cycle time	Sets the length of the PID cycle in seconds.	15	1 - 99
F8	Humidity Cycle time	Sets the length of time in seconds for each humidity cycle.	32	1 - 99
F9	Humidity On time	Sets the "on" time in seconds for humidity in each cycle.	04	0 - 20
F10	Refrigeration Defer time	Sets how long the control will delay the turning on of the cooling system in minutes.	0.0	0.0 - 9.9
F11	Cooling Dead Band	Temperature difference between cooling off and cooling on.	2.0	0.0 - 9.9
F12	Heating Dead Band	Temperature difference between heating on and heating off.	0.5	0.0 - 9.9
F13	Not used	Set to 0.5	005	0 - 9
F14	Light on time	How long the light will be on in seconds. "0.0" = light will be on indefinitely.	0.5	0.0 - 9.9
F15	Alarm on time	Determines how long the alarm will sound before it turns off, in seconds. "0.0" means the alarm will stay on indefinitely.	0.0	0.0 - 9.9
F16	Defrost time	Length of the defrost time in minutes. "00" = no defrost.	30	0.0 - 9.9
F17	Defrost delay	determines how long between starts of the defrost cycle in hours. "00" = no defrost.	08	0.0 - 9.9
F18	Defrost Temperature	Determines what temperature ends the defrost cycle, when a thermistor is imbedded in the evaporator.	32	00 - 200

F19	Over temperature alarm	Determines when the alarm will sound if the temperature runs away.	140	32 - 200
F20	Maximum temp set point	Determines how high the user can set the temperature.	105	32 - 140
F21	Minimum temp set point	Determines how low the user can set the temperature.	34	0 - 34
F22	F/C	Determines the scale of the temperature display.	F	F - C
F23	Unattended proofer delay	Determines how long the proofer can continue to humidify without having the door opened in minutes.	45	0 - 99
F24	Open Door turn-off delay	Determines how long the door can be left open in the proofing mode before the unit turns off in minutes.	10	0 - 20
F25	Legacy option	"0" = for old retarders, "1" = for new retarders after the addition of the door switch	0	0 - 1

Retarder/Proofer Time Clock Settings

LBC Retarder/Proofer controls are equipped with a real-time clock. This is used to determine when the automatic features of the control will happen.

To change the time of day on the clock:

- 1) Press the POWER button to turn the retarder/proofer control off.
- 2) Press and hold the TIME button for 5 seconds to enter the Clock-setting mode. The control will display "t-Yr __" for the current year.
- 3) Press the Up or Down Arrow buttons to adjust year.
- 4) Press the TIME button to advance to the current month. Adjust using the Up or Down Arrow buttons.
- 5) Press the TIME button to advance through the other settings:
 - A) "t-mo" for month
 - B) "t-do" for day
 - C) "t-wo" for week
 - D) "t-ho" for hour (in 24-hr clock time)
 - E) "t-mi" for minute
 - F) "t-SE" for seconds.
- 6) Press the POWER button to exit the clock adjusting mode.

Retarder/proofer Automatic Cycle Program Set-up

One of the features of the LBC Retarder/proofer is the ability to automatically convert from retarding or refrigerating a load of product, to proofing the same load for baking as a specific time, even on the following day. The retarder/proofer can automatically operate with one load for up to 24 hours.

To set up the control for automatic operation, there are some things that must be determined.

1. When will you bake?
2. How long will it proof?
3. How long will it temper?
4. When will you load retarder proofer?

Setting up the automatic timer requires that you work backwards in time. It is always best to do this on paper first.

- When you bake will be entered into the automatic timer as the **Finish** time.
- Subtract from the finish time the time required to proof to determine the **Start Proof** time.
- Subtract from Start Proof how long the product should rest to determine the **Start Rest** time. By experience we know that 90 minutes works best for this.
- Next determine when you want to load the retarder with product to determine **Start Retard**.
- Last subtract 1 hour to allow for adequate cool-down. This is the **Start Hold** time.

Here is an example:

Say you want to bake frozen bread for French loaves. You will be finished with your proofer at 3:00 PM or at 15:00. You plan on baking the first load the next day at 8:00 AM, 08:00. You generally proof the bread for 40 minutes.

- The **Finish Time** will be 08:00.
- The product will proof for 40 minutes so the **Start Proof** time will be 07:20.
- The product will need 90 minutes to rest (rise in temperature to room temperature) so the **Start Rest** time will be 05:50.
- The retarder/proofer should be allowed 1 hour to cool down so the **Start Retard** time will be 16:00.
- The **Hold Start** time will be 15:00.

To enter the start times:

1. Press the Time button to illuminate the LED that indicates **Hold Start** time. The decimal points in the hours display will be on to indicate you are setting hours. Press the up or down button to change the hour of the day, 15. Press the Temperature button to toggle to the minutes display. The decimal points in the minutes display will indicate you are setting minutes. Use the up or down buttons to adjust the minutes to 00.
2. Press the Time button to illuminate the LED that indicates **Retard Start** time. Use the up or down buttons along with the Temperature button to set 16:00.
3. Press the Time button to illuminate the LED that indicates **Rest Start** time. Use the up or down buttons along with the Temperature button to set 05:50.
4. Press the Time button to illuminate the LED that indicates **Proof Start** time. Use the up or down buttons along with the Temperature button to set 07:20.
5. Press the Time button to illuminate the LED that indicates **Finish** time. Use the up or down buttons along with the Temperature button to set 08:00.

Retarder/proofer Automatic Cycle Program Operation

To operate the Automatic Retard/proof Cycle, Press the “Auto/Manual” button to illuminate the LED next to the button indicating that the auto cycle is activated. When the hold start time occurs, the Hold function will start. If the Hold Start time has passed, the Hold Function will begin within 1 minute. The indicating LEDs on the time chart will indicate where the control is in the automatic cycle.

The temperature and humidity setting that are used in Manual Operation will also be used in the Automatic Operation. Here are the recommended settings:

- **Hold** temperature should be set to 32 degrees. Hold allows the retarder/proofer to cool down in preparation for retarding. Hold should not be used for more than 4 hours at any time.
- **Retard** temperature should be set to 40 degrees. Retard will be low enough to keep yeast from rising and high enough to melt any ice in the product.
- **Rest** temperature should be room temperature or 70 degrees. Rest humidity should be set to 45%. If humidity is too high, it will put too much moisture on the product. If it is too low, the product will dry out during the rest cycle.
- **Proof** temperature should be set to 90 to 105 degrees. Proof Humidity should be set to 85%.

At the end of the automatic cycle, the alarm will sound, and the retarder proofer control will shift to Manual mode. The next cycle will require only that the operator press the “Auto/Manual” button to start.

Note, if the door is left open, while in proof mode, the retarder/proofer may turn off, depending on other settings.

Refrigeration Evaporator Positioning, LRPR1

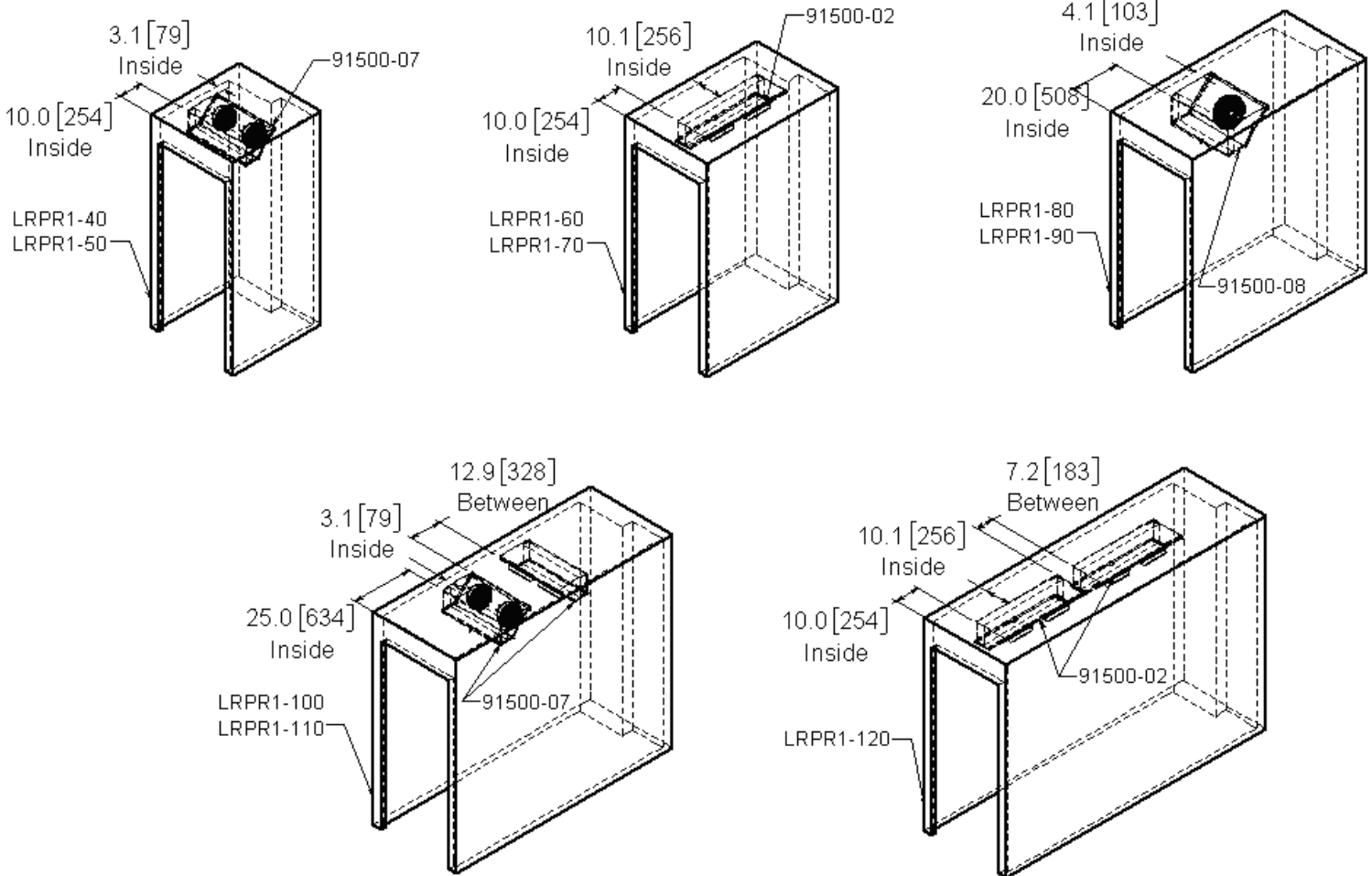

Refrigeration Evaporator Positioning, LRPR2N

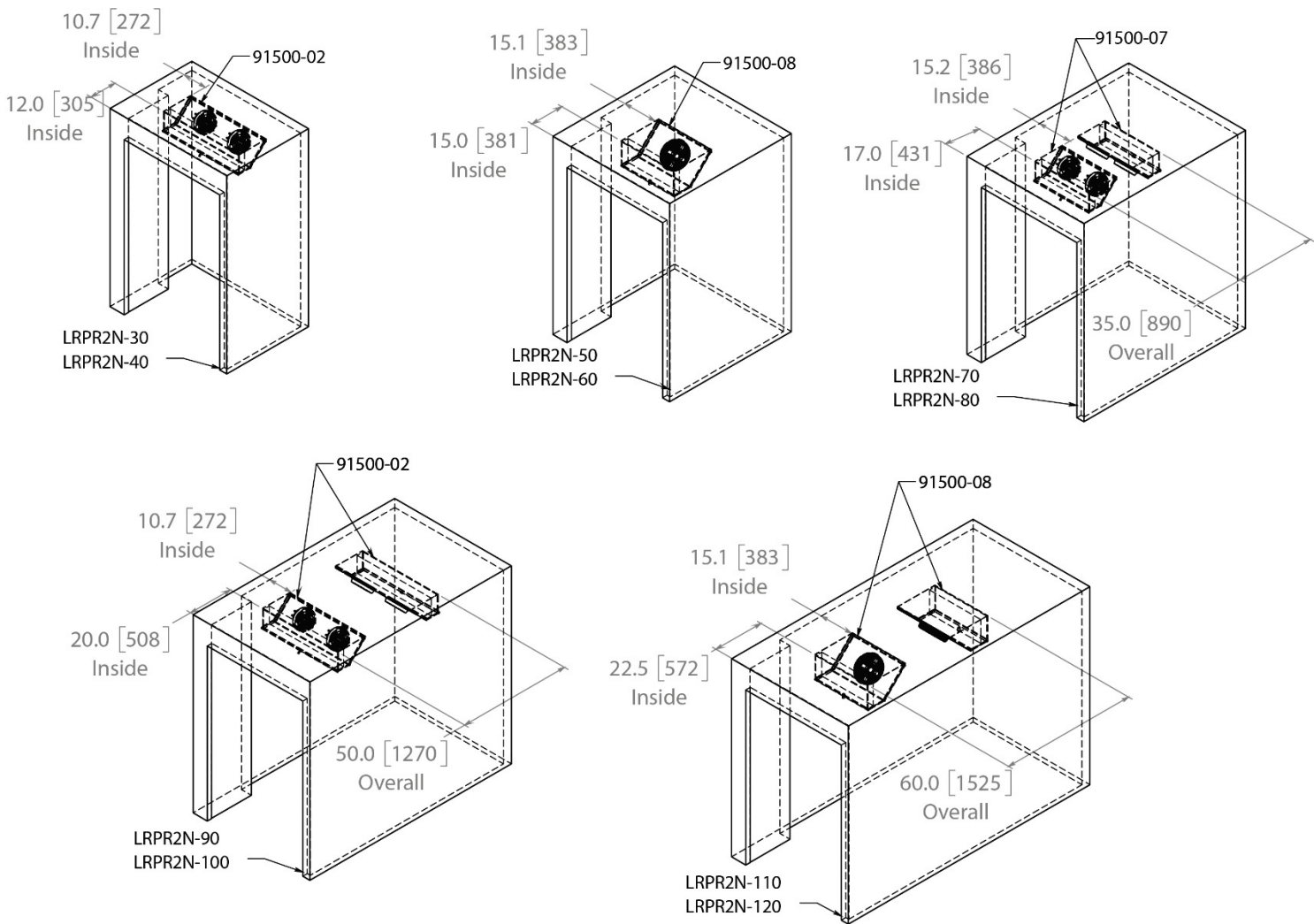

Refrigeration Evaporator Positioning, LRPR2S

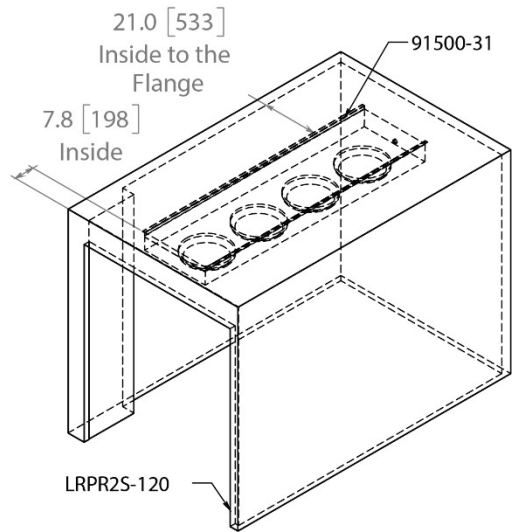
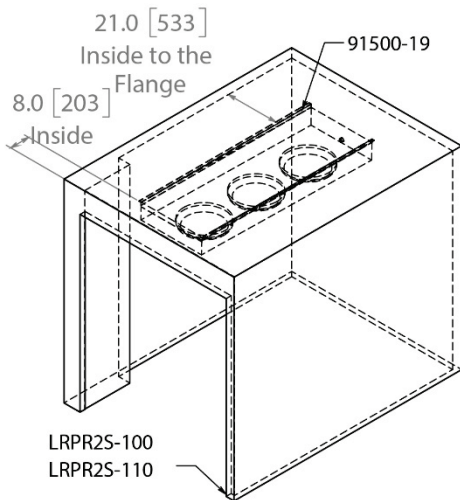
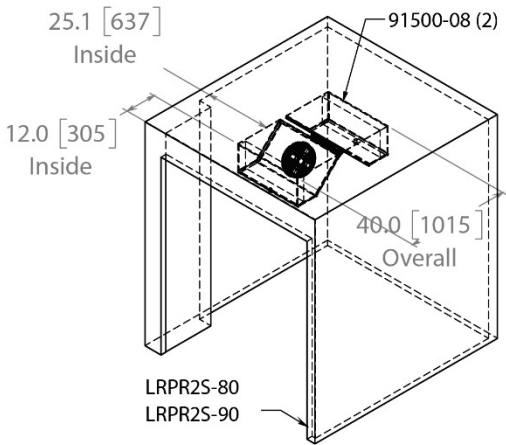
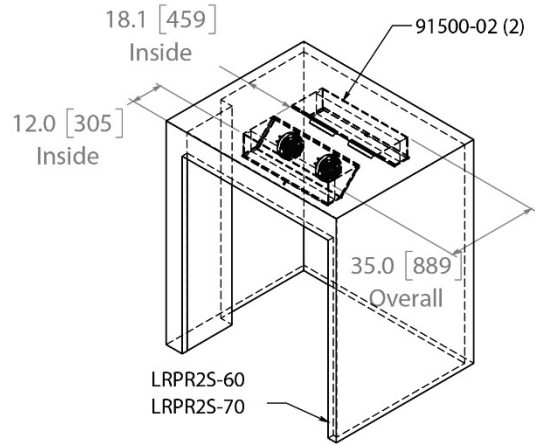
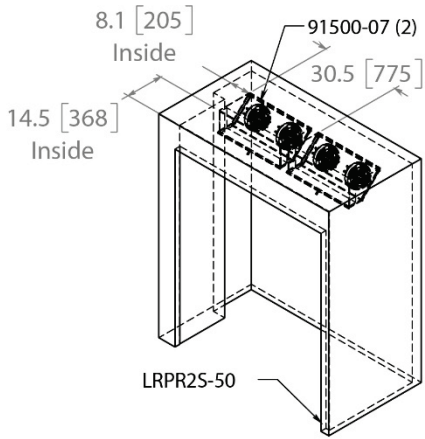
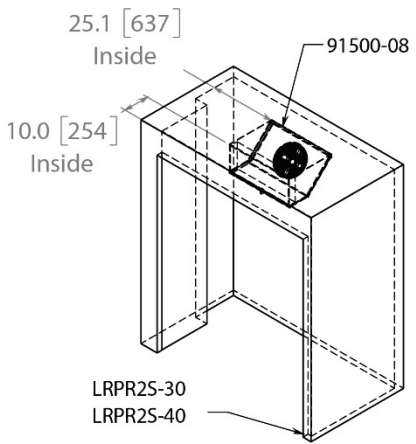

Refrigeration Evaporator Positioning, LRPR3

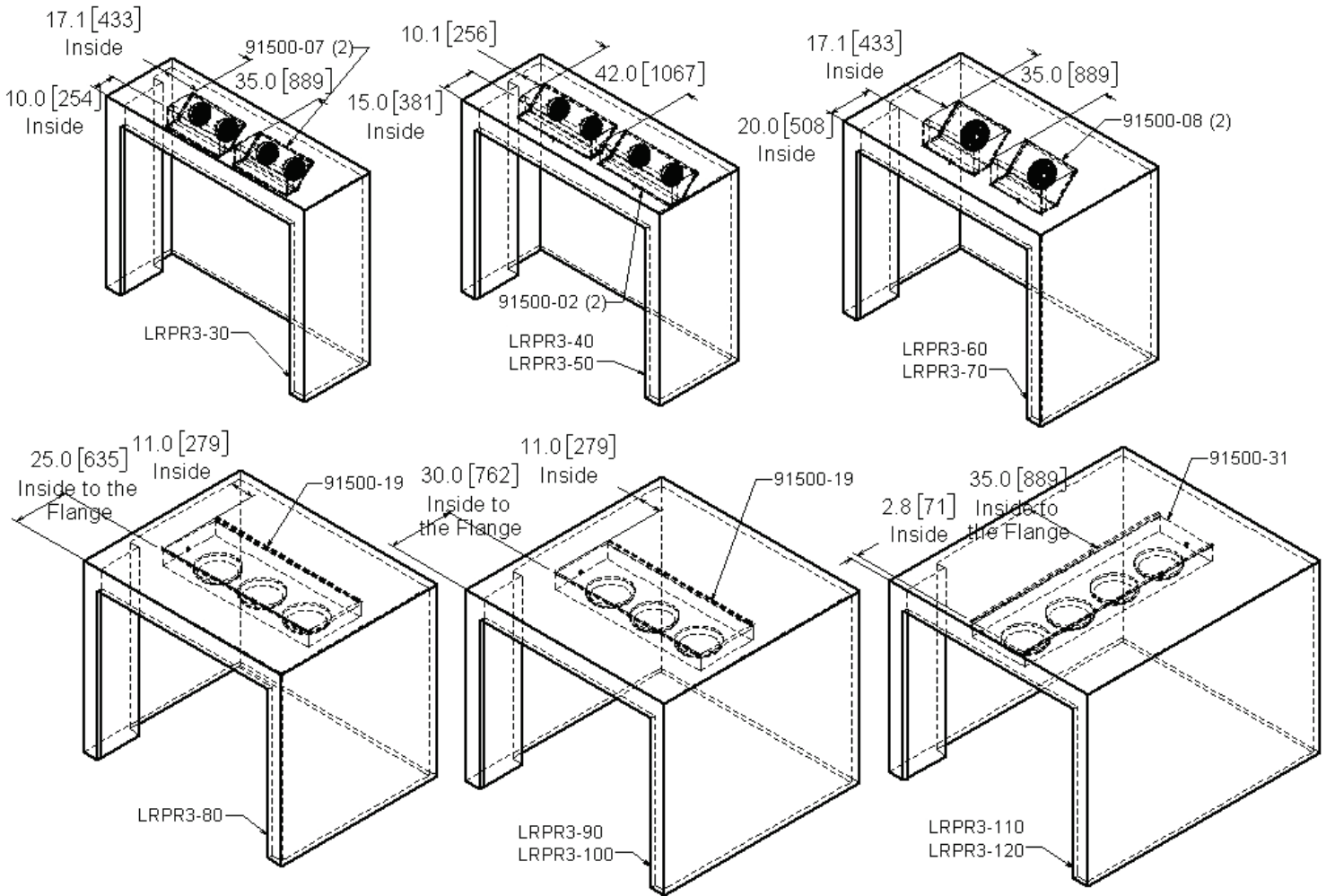

Retarder/Proofer Refrigeration Assembly and Wiring

1. Mount the Evaporator(s)

Locate the installation kit (72610-35) which includes the mounting hardware for the evaporator. When there are two evaporators or a large evaporator, there may be more than one mounting kit. Remove the cover from the evaporator(s) and disconnect any wires holding the cover. Reinstall the screws from the cover for safe keeping.

2. Mark the Ceiling

Refer to the Evaporator positioning drawings on the previous pages for the specific retarder/proofer you are installing. Knock-out any knock-out plugs that are on the top of the evaporator(s). Mark the dimensions from the positioning page drawing on the underside of the ceiling. With assistance, hold the evaporator against the bottom of the ceiling and mark the mounting hole positions and the knock-out locations.

3. Drill the Ceiling

Use the 3/8" drill bit provided to drill through the ceiling at the locations you marked. Always wear eye protection. Drill a 7/8" hole for the electrical wires where you have marked. Drill a 1-3/8" hole for the refrigeration lines where you have marked.

4. Hang the Evaporators

With assistance, bolt the evaporator(s) in position. Install the 1/4-20 x 3" screws from the bottom. Install the flat washer and Nylock nuts from the top.

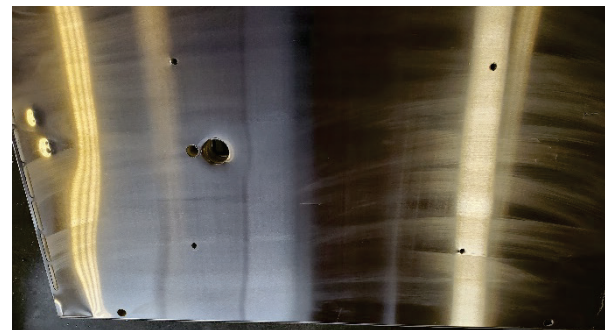

5. Prepare Fan Wires

Remove the cover from the small electrical box inside the evaporator. Install a plastic bushing (from kit) in the side of the electrical box and into the 7/8 hole drilled in the ceiling.

Connect two wires to the fan wires in this box with wire nuts provided. Wrap the wire nuts with electrical tape to prevent them from coming loose and to keep moisture out. Route these two wires through the two plastic bushings and out to the top of the ceiling. Re-install the cover on the evaporator.

6. Position and Install Condenser

If a condenser is supplied with the retarder/proofer, install it on the top of the unit. Position the condenser as follows:

- Near the center of the top of the unit.
- Positioned to optimize the routing of the liquid line and the suction line to the hole in the ceiling.
- Away from locations where airflow across the coils would be obstructed.

7. Mount the Condenser

Mark the mounting holes on the ceiling of the unit. You need two holes minimum. Check the hole locations on the bottom of the ceiling to insure you will not drill into the coils of the climatizer or through ceiling cam latches. Drill through the ceiling using the 3/8" drill bit provided.

With assistance, bolt the condenser in position. Install the 1/4-20 x 3" screws from the bottom. Install the flat washer and Nylock nuts from the top.



8. Install Electrical Box(s)

Install electrical junction box(s) on the ceiling at each evaporator. Knock out one hole in the bottom of the junction box and insert a 7/8" plastic bushing. Route the two evaporator wires through this bushing and install the junction box at the hole with the 7/8" bushing fitting through both the junction box and the 7/8" hole you drilled through the ceiling. Attach the box(s) with self-drilling screws provided.

9. Install Flex Conduit

Two electrical wires are needed at the following locations:

- At the control valance, to connect to wires #18 and #19.
- At the climatizer connection junction box(s) you just installed.
- At the liquid line solenoid valve to be installed at the condenser.

Knock out the appropriate holes in the junction box(s) and install flex conduit connectors at these locations. At the back of the control valance, there is an oversized hole. Use the hole adaptor washers provided. Install 3/8" Flex conduit to each connector. Secure the conduit to the top of the ceiling within 12 inches of each connector.

10. Install wires

Route and connect electrical wires. Use the wire nuts provided. Wrap wire nuts with electrical tape.

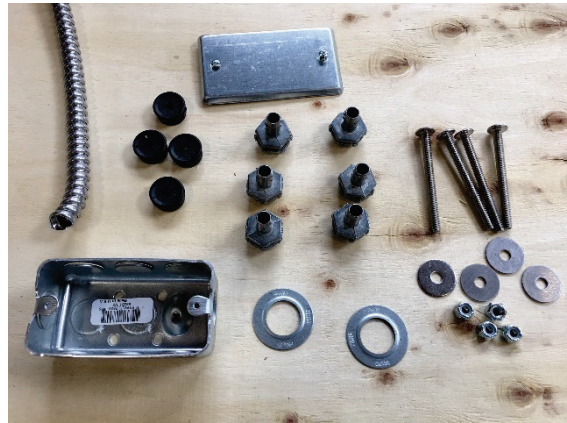

9. Install refrigeration line components

Install the expansion valve at the inlet side of the evaporator. Follow the instructions provided with the expansion valve to avoid damaging the internal components. Note, Evaporators #91500-02 have an externally compensated expansion valve and require three connections

Caution: Use only silver braze or silver solder to connect refrigeration lines. Always wrap components with a wet rag to protect internal components.

Route the liquid line and the suction line to the top of the unit. Install the bulb on the expansion valve as shown in the instructions provided with the expansion valve.

Install a Schrader valve tee on units with condenser model 91500-15. This will be used for installation of a suction side pressure switch later.

Connect the suction line to the suction side King Valve on the condenser. Note, condensers are shipped with a small charge of dry nitrogen to keep moisture out.

Connect the liquid line solenoid valve to the liquid line connection on the condenser as shown. Make sure that the solenoid valve is installed with the arrows on the body pointing away from the condenser and toward the evaporator. Wrap all components with a wet rag before soldering.

Connect the output of the liquid line solenoid valve to the liquid line from the evaporator.

Install the suction side pressure switch on condensers #91500-13, -14, -15. Electrical connection will be discussed later.



Evacuation and Refrigerant Charging

Caution: Evacuation of a refrigeration system and charging with refrigerant must be performed by a qualified and licensed professional.

Refer to the table in this manual in the section marked **Refrigeration Condenser Specification** for the proper refrigerant and pump-down charge capacity.

Condenser Electrical Connection

The condensing unit on each retarder/proofer **must be powered by a separate electrical supply.** Refer to the specification pages 4 thru 8 of this manual for the retarder/proofer you are installing.

For retarder/proofers with condensers numbers [91500-13](#), 91500-14 and 91500-15, connect the supply circuit to the condenser electrical connection with the suction side pressure switch blue wires wired in to interrupt the electrical supply when the suction side pressure drops below 35 PSI

Evaporator Drain Connection

Use the drain line connection components supplied with the retarder/proofer to connect the drain fitting on the evaporator to the climatizer drain line as shown.

Hook up drain. **Note: Install union at evaporator to allow for servicing.**

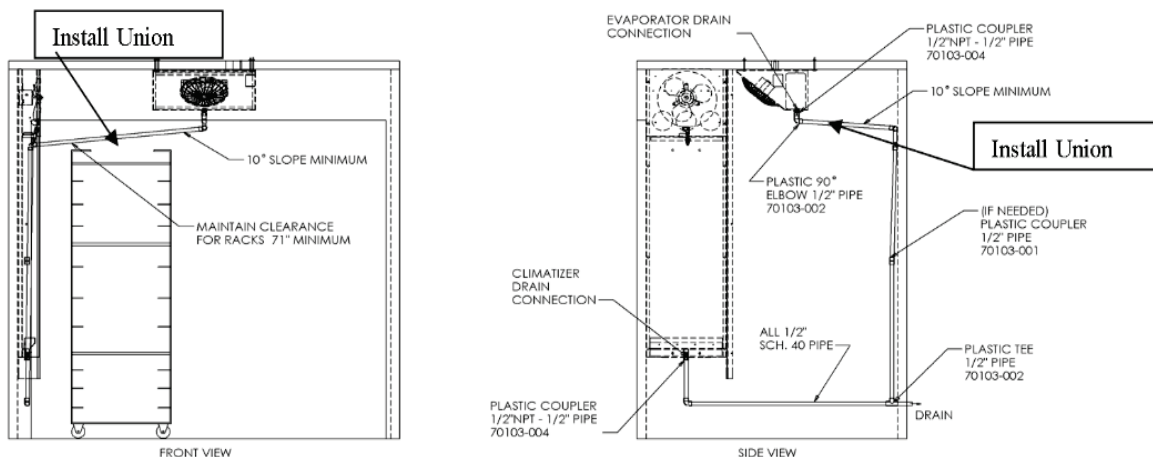

Cooling System Test and Adjustment

Once the retarder/proofer is completed and electrical supply is connected to both the retarder/proofer and separately to the condenser, the cooling system can be started up and tested.

Here are the specific requirements once the system is running:

- Nominal Operating Temperature: The refrigeration components are sized to operate at a process temperature of 35F. as such, the thermostat should not be set below 35 degrees for very long.
- The nominal suction side temperature is 25F.
- The condenser superheat (temperature rise above the saturation temperature) is 25 to 40 degrees. That means that the condenser should see between 50F to 65F degree return refrigerant. A simple way to check this is to put your hand on the top of the compressor when operating. The temperature should be about room temperature or less. There should never be frost on the condenser or the suction lines.
- The full-load amps (FLA) for the condenser are marked on the top. Use an amp probe to check. The FLA value should not be exceeded.

If any of the above are out of range, adjust the expansion valve to compensate. The nominal setting on the expansion valve for evaporators number 91500-02, -07, -08 is 3.5 turns counterclockwise from fully seated. The expansion valve on evaporators number 91500-19 and -31 should be fully open.

Be sure that the system does not flood the condenser with liquid refrigerant. If it does, close the expansion valve at least one turn and retest.

Once completed, the cooling system should be able to cool the unit from 80F to 40F in less than 1 hour.

Limited Warranty

LBC Bakery Equipment ("LBC Equipment") has been skillfully manufactured, carefully inspected and packaged to meet rigid standards of excellence. LBC Bakery Equipment, Inc. (LBC) warrants products produced and sold by LBC and its duly authorized agents, against defects in materials and workmanship within the following limitations:

What is Provided:

- Limited replacement parts as specified below, including standard ground shipping from LBC or service parts center when required.
- Limited labor for repair as specified below, including authorized service agent's transportation, portal to portal, up to one hundred (100) miles round trip and two (2) hours travel time.
- LBC, or an authorized service representative, will repair at LBC's sole discretion, any new LBC equipment, according to the limits and exclusions listed in this limited warranty.

Coverage Period:

Extending from the date of shipment from LBC or its duly authorized dealer/distributor for the specified period.

- **LBC Equipment** (Rack Ovens, Proofers, Retarder/proofer, Retarders, Rotisseries, Deck Ovens, Conveyor Ovens) shall be warranted for a period of one (1) year, limited parts and labor.
- **Heat Exchanger Tubes** on oven models LRO-1G5 and LRO-2G5 for a period of ten (10) years, limited parts and labor.
- **Replacement Parts** purchased from LBC or Authorized supplier shall be warranted for a period of ninety (90) days after installation by an authorized LBC service agent.

Conditions:

- Covered equipment must have been properly installed and according to the requirements of the installation manual and all applicable local codes.
- An **Equipment Start-Up must** have been performed by an authorized LBC servicer and the completed start-up form returned to LBC.
- The equipment shall not have been abused, misused or neglected or used for purposes other than intended by LBC.
- Water connected to the appliance shall have been in compliance with the following requirements:
 - Cold water, 40 to 80 PSI (Hot water to Rotisseries)
 - pH between 7 and 7.5
 - Conductivity less than 1/500,000 Ω per inch
 - Total dissolved solids less than 100 ppm
 - Hardness from 6.3 to 8.8 grains per gallon
 - Maximum Salinity and Ion content:
 - Chlorides:* < 30 ppm
 - Sulfates:* < 40 ppm
 - Iron:* < 0.1 ppm
 - Copper:* < 0.05 ppm
 - Manganese:* < 0.05 ppm

It is the responsibility of the purchaser to install and maintain the water supply to the appliance. Failure to provide satisfactory water quality to the appliance in accordance with the operating manual requirements can cause damage to internal components and will VOID the warranty.

Conditions (cont):

- All repair work is to be performed by an LBC authorized service agent.
- Equipment must be at the operating location of the original purchaser/user and shall not have been resold or reclaimed by another party.
- LBC equipment is for commercial use only. If sold as a component of another (OEM) manufacturer's equipment, or if used as a consumer product, such equipment is sold AS IS and without any warranty.
- Conditions of sale of the equipment shall have been met in full.
- The request for repair shall be made within the limited period of the warranty.

Failure to meet the above conditions will void this warranty

Exclusions:

This warranty does not cover the following:

- Routine general maintenance, or periodic adjustment
- Consumable items including but not limited to, light bulbs, glass, door gaskets, rack bumpers etc.
- Thermostat calibration after the first 30 days of use
- Air and gas burner adjustments
- Fuse replacement
- Cleaning and adjusting burners, pilot burners or heat exchangers
- Rack oven shutter adjustments
- Repairs, adjustments and corrections in the refrigeration portion of retarder/proofer resulting from the improper installation
- Retightening of screws and fasteners
- Failures caused by erratic or inadequate electrical, water, ventilation or gas service
- Unauthorized repairs
- Premature rusting, corrosion, or mineral build up caused by incoming water
- Attached water treatment systems
- Expedited freight on replacement parts other than standard ground shipments
- Ordinary wear and tear
- Use of the equipment for purposes other than those intended including non-commercial use such as residential or domestic
- Appliances installed outside the contiguous U.S., including Alaska and Hawaii, and Canada
- Incidental costs, charges, loss of business and damages as incurred by the user or others as a result of the use or failure of the equipment
- Work and workmanship of the authorized service agent or others in the repair of the equipment
- Other failures that are beyond the reasonable scope of this warranty
- Damages caused during shipment are to be reported to the carrier, are not covered under this warranty, and are the sole responsibility of the purchaser/user
- Natural disaster

This warranty is exclusive and in lieu of all other warranties, expressed or implied, including expressed or implied warranties of merchantability or fitness for a particular purpose, each of which is hereby expressly disclaimed. The remedies described herein are exclusive and in no event shall LBC be liable for special, consequential or incidental damages for the breach or delay in the performance of this warranty.