



SINMAG

Manufacturers of Bakery and Foodservice Equipment



Models LPR and LRPR

***Roll-in Rack Proofer and Retarder-Proofer
Installation, Service and Parts Manual***

LBC Bakery Equipment, Inc.

6026 31st Ave NE

Tulalip, WA 98271, USA





Phone: 888-RACKOVN (888-722-5686)

Fax: 425-642-8310

Email: service@lcbakery.com

Website: www.lcbakery.com

THE INFORMATION IN THIS MANUAL IS CRUCIAL AND MUST BE RETAINED FOR FUTURE REFERENCE. READ, UNDERSTAND, AND FOLLOW THE INSTRUCTIONS AND WARNINGS CONTAINED IN THIS MANUAL.

<u>DANGER</u>	POTENTIALLY HAZARDOUS SITUATION WHICH, IF NOT AVOIDED, COULD RESULT IN DEATH.	
<u>WARNING</u>	POTENTIALLY HAZARDOUS SITUATION WHICH, IF NOT AVOIDED, COULD RESULT IN DEATH OR SERIOUS INJURY.	
<u>CAUTION</u>	POTENTIALLY HAZARDOUS SITUATION WHICH, IF NOT AVOIDED, MAY RESULT IN MINOR OR MODERATE INJURY.	
<u>NOTICE</u>	Helpful operation and installation instructions and tips are present.	

FOR YOUR SAFETY

DO NOT STORE OR USE GASOLINE OR OTHER FLAMMABLE VAPORS AND LIQUIDS IN THE VICINITY OF THIS OR ANY OTHER APPLIANCE.

WARNING: IMPROPER INSTALLATION, ADJUSTMENT, ALTERATION, SERVICE OR MAINTENANCE CAN CAUSE PROPERTY DAMAGE, INJURY OR DEATH. READ THE INSTALLATION, OPERATING AND MAINTENANCE INSTRUCTIONS THOROUGHLY BEFORE INSTALLING OR SERVICING THIS EQUIPMENT.

Model #:	Purchased From:
Serial #:	Location:
Date Purchased:	Date Installed:
Purchase Order #:	For Service, Call:

TABLE OF CONTENTS

CHAPTER	PAGE
TABLE OF CONTENTS	3
SPECIFICATION SHEETS	4
CONDITIONS OF INSTALLATION	12
READ FIRST	14
SAFETY PROCEDURES, LOCK-OUT	16
ASSEMBLY	17
ELECTRICAL SUPPLY CONNECTIONS	37
RETARDER/PROOFER ONLY	38
REFRIGERATION INFORMATION	47
ELECTRICAL SCHEMATICS	48
PARTS	52
WARRANTY	56

EQUIPMENT DESCRIPTION

Roll-In Proofer

MODEL: LRP1 Series

INSTALLATION REQUIREMENT

Ships KD requires on-site installation
 208/120 or 240/120 1-phase or 3-phase

1/2" NPT Cold water connection
 3/4" Copper vented drain connection

OPTIONS & ACCESSORIES

Stainless Steel Floor

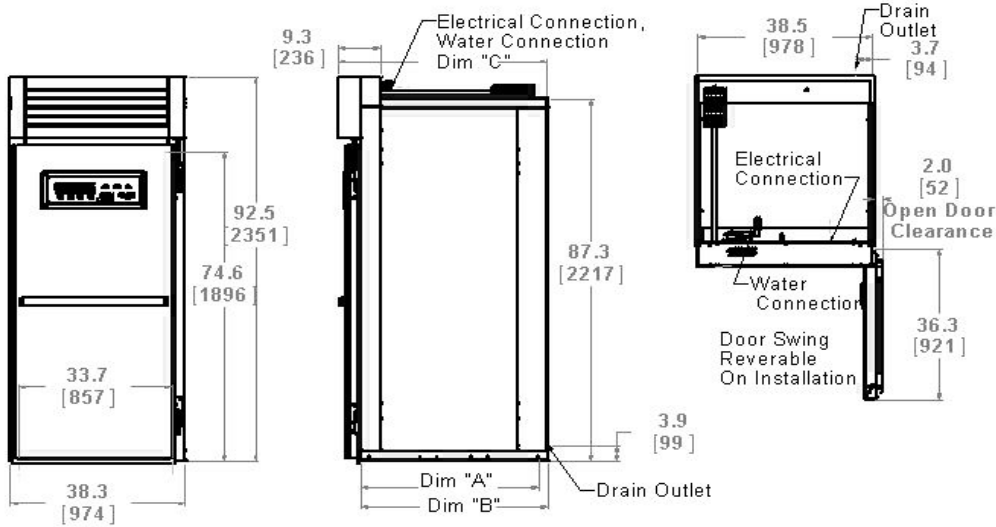

Model	Depth			Width	Weight		Freight Class	
	Internal "A"	Ext. "B"	Over All "C"		Actual	Ship		
LRP1-40	32.1	41	49.3	38.3	892	992	70	
LRP1-50	42.1	51	59.3	38.3	991	1116	70	
LRP1-60	52.1	61	69.3	38.3	1094	1219	70	
LRP1-70	62.1	71	79.3	38.3	1197	1322	70	
LRP1-80	72.1	81	89.3	38.3	1321	1446	70	
LRP1-90	82.1	91	99.3	38.3	1424	1549	70	
LRP1-100	92.1	101	109.3	38.3	1527	1652	70	
LRP1-110	102.1	111	119.3	38.3	1651	1776	70	
LRP1-120	112.1	121	129.3	38.3	1754	1879	70	
Total Electrical Requirements By Model								
Model	Voltage	Total kW	*MCA		*Max Fuse		Water	Drain
			1-Ph	3-PH	1-Ph	3-Ph		
LRP1-(40 -120)	208/120 VAC	5	30	20	50	50	1/2" NPT .07 GPM @ 60 PSI	1/2"PVC; 210 F; <1 GPM Max.
	240/120 VAC	6.6	35	20	50	50		

This Appliance is designed to operate at normal room temperatures. Clearance from combustibles is 0.0" sides and back, For Install on non-porous surfaces only

***MCA: Minimum Circuit Ampacity. *Max Fuse: Maximum allowable circuit protector.**

IMPORTANT: Your local water conditions may damage your LBC appliance. Failure to properly treat water may result in damage and may void your warranty. Ensure that your water supply meets these minimum specification.

Parameter	Unit	Value
Alkalinity	ppm	22
Aluminium	ppb	17
Calcium	ppm	3.3
Free Chlorine Residual	ppm	0.6

Parameter	Unit	Value
Magnesium	ppm	0.65
pH	s.u.	8.5
Sodium	ppm	8.5
Total Hardness	ppm	11.9

INSTALLATION REQUIREMENT

Ships KD requires on-site installation
 208/120 or 240/120 VAC 1 or 3-phase

1/2" NPT Cold water conection
 3/4" Copper vented drain connection

OPTIONS & ACCESSORIES

Stainless Steel Floors

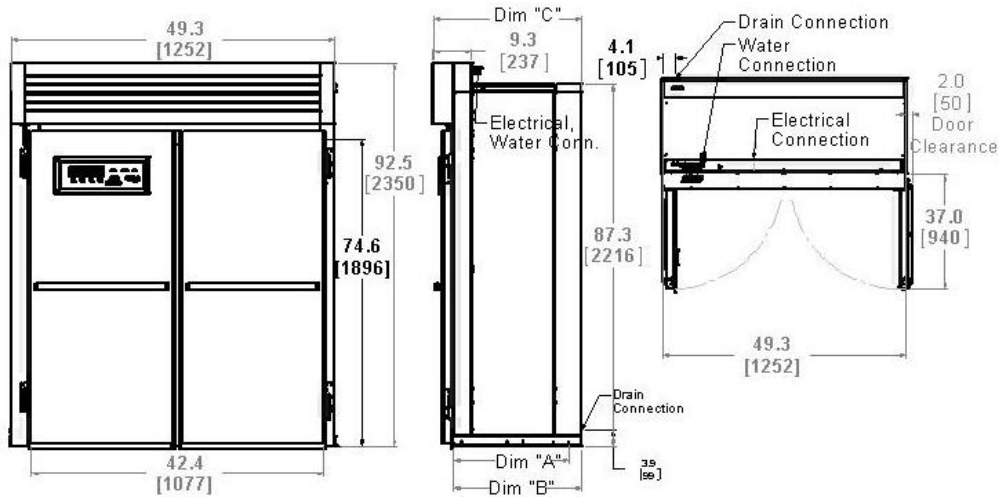

Model	Depth			Width	Weight		Freight Class
	Internal "A"	Ext. "B"	Over All "C"		Actual	Ship	
LRP15-40	31.4	41	49.3	49.3	1107	1232	70
LRP15-50	41.4	51	59.3	49.3	1279	1404	70
LRP15-60	51.4	61	69.3	49.3	1336	1461	70
LRP15-70	61.4	71	79.3	49.3	1418	1543	70
LRP15-80	71.4	81	89.3	49.3	1565	1690	70
LRP15-90	81.4	91	99.3	49.3	1824	1949	70
LRP15-100	91.4	101	109.3	49.3	1881	2006	70
LRP15-110	101.4	111	119.3	49.3	2053	2178	70
LRP15-120	111.4	112	129.3	49.3	2110	2235	70

Total Electrical Requirements By Model

Model	Voltage	Total kW	*MCA		*Max Fuse		Water	Drain
			1-Ph	3-Ph	1-Ph	3-Ph		
LRP15-(all)	208/120 VAC	5	30	18	50	50	1/2" NPT .07 GPM @ 60 PSI	1/2"PVC; 210 F; <1 GPM Max.
	240/120 VAC	6.6	34	20	50	50		

This Appliance is designed to operate at normal room temperatures; Clearance from combustibles is 0.0" sides and back, For Install on non-porous surfaces only

***MCA: Minimum Circuit Ampacity. *Max Fuse: Maximum allowable circuit protector.**

IMPORTANT: Your local water conditions may damage your LBC appliance. Failure to properly treat water may result in damage and may void your warranty. Ensure that your water supply meets these minimum water quality specification.

Parameter	Unit	Value
Alkalinity	ppm	22
Aluminium	ppb	17
Calsium	ppm	3.3
Free Chlorine Residual	ppm	0.6

Parameter	Unit	Value
Magnesium	ppm	0.65
pH	s.u.	8.5
Sodium	ppm	8.5
Total Hardness	ppm	11.9

INSTALLATION REQUIREMENT

Ships KD requires on-site installation
 208/120 or 240/120 VAC 1 or 3-phase

1/2" NPT Cold water connection
 3/4" Copper vented drain connection

OPTIONS & ACCESSORIES

Stainless Steel Floors

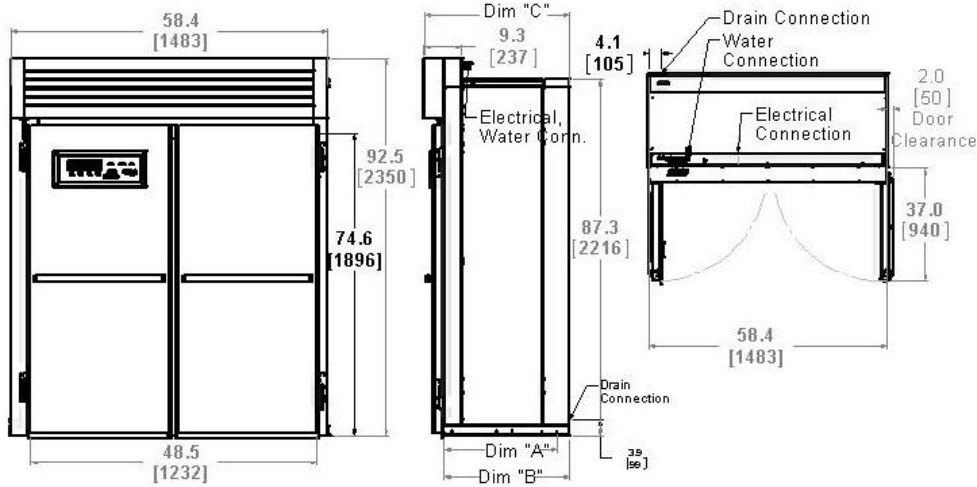

Model	Depth			Width	Weight		Freight Class
	Internal "A"	Ext. "B"	Over All "C"		Actual	Ship	
LRP2N-30	26.1	31.1	39.3	58.4	1070	1170	70
LRP2N-40	36.1	41.1	49.3	58.4	1102	1227	70
LRP2N-60	56.1	61.1	69.3	58.4	1306	1431	70
LRP2N-70	66.1	71.1	79.3	58.4	1363	1488	70
LRP2N-80	76.1	81.1	89.3	58.4	1510	1635	70
LRP2N-100	96.1	101.1	109.3	58.4	1801	1926	70
LRP2N-110	106.1	111.1	119.3	58.4	1948	2073	70

Total Electrical Requirements By Model

Model	Voltage	Total kW	*MCA		*Max Fuse		Water	Drain
			1-Ph	3-Ph	1-Ph	3-Ph		
LRP2- (all)	208/120 VAC	5	30	18	50	50	1/2" NPT .07 GPM @ 60 PSI	1/2"PVC; 210 F; <1 GPM Max.
	240/120 VAC	6.6	34	20	50	50		

This Appliance is designed to operate at normal room temperatures; Clearance from combustibles is 0.0" sides and back, For Install on non-porous surfaces only

***MCA: Minimum Circuit Ampacity. *Max Fuse: Maximum allowable circuit protector.**

IMPORTANT: Your local water conditions may damage your LBC appliance. Failure to properly treat water may result in damage and may void your warranty. Ensure that your water supply meets these minimum water quality specification.

Parameter	Unit	Value
Alkalinity	ppm	22
Aluminium	ppb	17
Calcium	ppm	3.3
Free Chlorine Residual	ppm	0.6

Parameter	Unit	Value
Magnesium	ppm	0.65
pH	s.u.	8.5
Sodium	ppm	8.5
Total Hardness	ppm	11.9

Roll-In Proofer

MODEL: LRP2 Series

INSTALLATION REQUIREMENT

Ships KD requires on-site installation
 208/120 or 240/120 VAC 1 or 3-phase

1/2" NPT Cold water conection
 3/4" Copper vented drain connection

OPTIONS & ACCESSORIES

Stainless Steel Floors

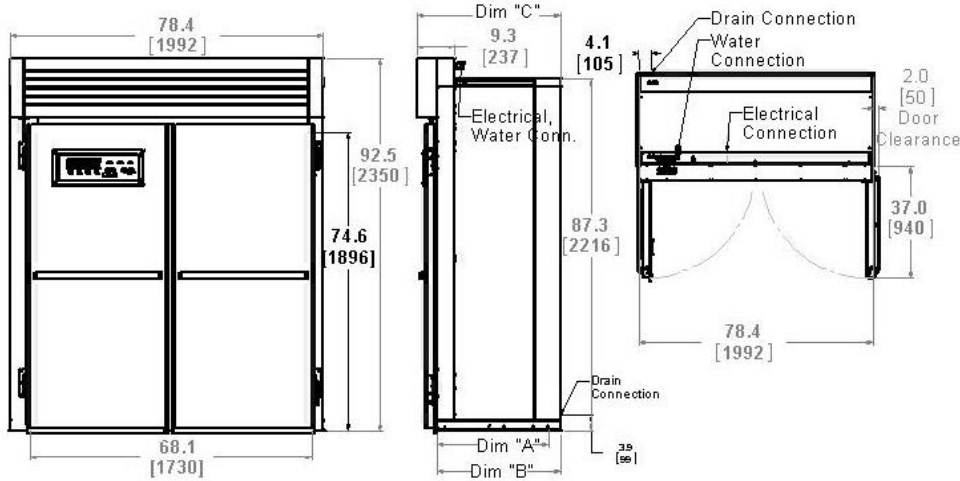

Model	Depth			Width	Weight		Freight Class
	Internal "A"	Ext. "B"	Over All "C"		Actual	Ship	
LRP2-30	26.1	31.1	39.3	78.4	1100	1200	70
LRP2-40	36.1	41.1	49.3	78.4	1157	1282	70
LRP2-50	46.1	51.1	59.3	78.4	1329	1454	70
LRP2-60	56.1	61.1	69.3	78.4	1411	1536	70
LRP2-70	66.1	71.1	79.3	78.4	1493	1618	70
LRP2-80	76.1	81.1	89.3	78.4	1665	1790	70
LRP2-90	86.1	91.1	99.3	78.4	1924	2049	70
LRP2-100	96.1	101.1	109.3	78.4	2006	2131	70
LRP2-110	106.1	111.1	119.3	78.4	2178	2303	70
LRP2-120	116.1	121.1	129.3	78.4	2260	2385	70

Total Electrical Requirements By Model

Model	Voltage	Total kW	*MCA		*Max Fuse		Water	Drain
			1-Ph	3-Ph	1-Ph	3-Ph		
LRP2- (40-80)	208/120 VAC	5	30	18	50	50	1/2" NPT .07 GPM @ 60 PSI	1/2"PVC; 210 F; <1 GPM Max.
	240/120 VAC	6.6	34	20	50	50		
LRP2- (90-120)	208/120 VAC	10.2	NA	35	NA	60	1/2" NPT .14 GPM @ 60 PSI	1/2"PVC; 210 F; <1 GPM Max.
	240/120 VAC	13.2	NA	39	NA	60		

This Appliance is designed to operate at normal room temperatures; Clearance from combustibles is 0.0" sides and back, For install on non-porous surfaces only

***MCA: Minimum Circuit Ampacity. *Max Fuse: Maximum allowable circuit protector.**

IMPORTANT: Your local water conditions may damage your LBC appliance. Failure to properly treat water may result in damage and may void your warranty. Ensure that your water supply meets these minimum water quality specification.

Parameter	Unit	Value
Alkalinity	ppm	22
Aluminium	ppb	17
Calcium	ppm	3.3
Free Chlorine Residual	ppm	0.6

Parameter	Unit	Value
Magnesium	ppm	0.65
pH	s.u.	8.5
Sodium	ppm	8.5
Total Hardness	ppm	11.9

Roll-In Proofer

MODEL: LRP3 Series

INSTALLATION REQUIREMENT

Ships KD requires on-site installation
208/120 or 240/120 VAC 1 or 3-phase

1/2" NPT Cold water connection
 3/4" Copper vented drain connection

OPTIONS & ACCESSORIES

Stainless Steel Floors

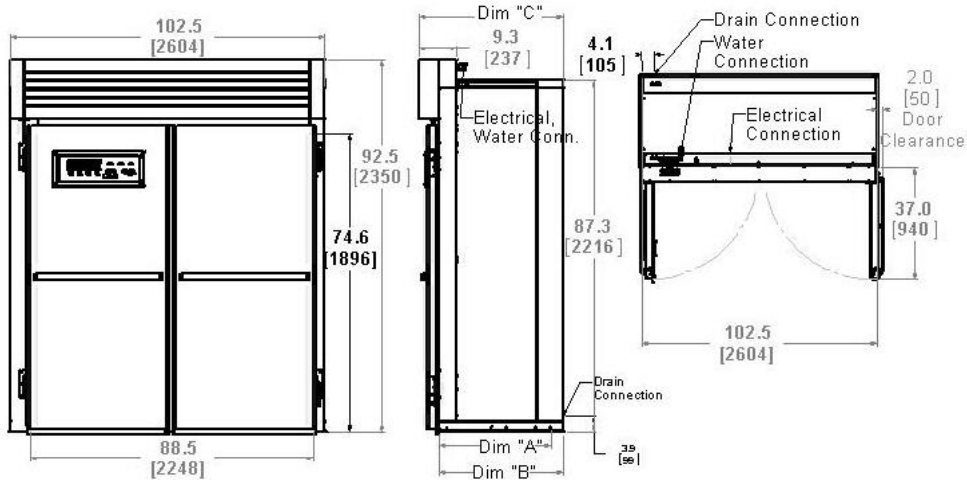

Model	Depth			Width	Weight		Freight Class
	Internal "A"	Ext. "B"	Over All "C"		Actual	Ship	
LRP3-30	26.1	31.1	39.3	102.5	1172	1472	70
LRP3-40	36.1	41.1	49.3	102.5	1282	1582	70
LRP3-50	46.1	51.1	59.3	102.5	1422	1722	70
LRP3-60	56.1	61.1	69.3	102.5	1532	1832	70
LRP3-70	66.1	71.1	79.3	102.5	1642	1942	70
LRP3-80	76.1	81.1	89.3	102.5	1782	2082	70
LRP3-90	86.1	91.1	99.3	102.5	2069	2369	70
LRP3-100	96.1	101.1	109.3	102.5	2179	2479	70
LRP3-110	106.1	111.1	119.3	102.5	2319	2619	70
LRP3-120	116.1	121.1	129.3	102.5	2429	2729	70

Total Electrical Requirements By Model

Model	Voltage	Total kW	*MCA		*Max Fuse		Water	Drain
			1-Ph	3-Ph	1-Ph	3-Ph		
LRP3- (30-80)	208/120 VAC	5	30	18	50	50	1/2" NPT .07 GPM @ 60 PSI	1/2"PVC; 210 F; <1 GPM Max.
	240/120 VAC	6.6	34	20	50	50		
LRP3- (90-120)	208/120 VAC	10.2	NA	35	NA	60	1/2" NPT .14 GPM @ 60 PSI	1/2"PVC; 210 F; <1 GPM Max.
	240/120 VAC	13.2	NA	39	NA	60		

This Appliance is designed to operate at normal room temperatures; Clearance from combustibles is 0.0" sides and back, For install on non-porous surfaces only

***MCA: Minimum Circuit Ampacity. *Max Fuse: Maximum allowable circuit protector.**

IMPORTANT: Your local water conditions may damage your LBC appliance. Failure to properly treat water may result in damage and may void your warranty. Ensure that your water supply meets these minimum water quality specification.

Parameter	Unit	Value
Alkalinity	ppm	22
Aluminium	ppb	17
Calcium	ppm	3.3
Free Chlorine Residual	ppm	0.6

Parameter	Unit	Value
Magnesium	ppm	0.65
pH	s.u.	8.5
Sodium	ppm	8.5
Total Hardness	ppm	11.9

High Output Roll-In Retarder Proofer

MODEL: LRPR1 -HO Series

INSTALLATION REQUIREMENT

Ships KD requires on-site installation

208/120 or 240/120 1-phase or 3-phase

Refrigeration system may require installation by a licensed refrigeration technician

1/2" NPT Cold water connection

3/4" Copper vented drain connection

OPTIONS & ACCESSORIES

Refrigeration Condenser Stainless Steel Floor

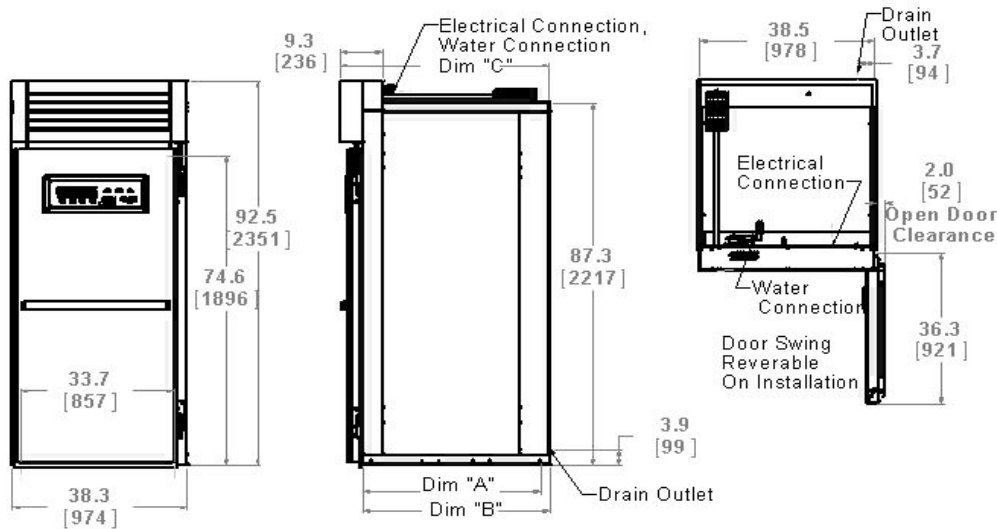

Model	Retarder BTU Rating @ 35 Deg F	Optional Condenser Specs				Depth			Weight		Freight Class
		Part No.	HP	*MCA	*Max Fuse	Internal "A"	Ext. "B"	Over All "C"	Actual	Ship	
LRPR1-40HO	3500	-13	1/3	5.8	15	32.1	41	49.3	900	1000	70
LRPR1-50HO	3500	-13	1/3	5.8	15	42.1	51	59.3	991	1116	70
LRPR1-60HO	4500	-14	1/2	6.7	15	52.1	61	69.3	1094	1219	70
LRPR1-70HO	4500	-14	1/2	6.7	15	62.1	71	79.3	1197	1322	70
LRPR1-80HO	5500	-15	1/2+	8.1	15	72.1	81	89.3	1321	1446	70
LRPR1-90HO	5500	-15	1/2+	8.1	15	82.1	91	99.3	1424	1549	70
LRPR1-100HO	7000	-18	3/4	8.8	15	92.1	101	109.3	1527	1652	70
LRPR1-110HO	7000	-18	3/4	8.8	15	102.1	111	119.3	1651	1776	70
LRPR1-120HO	9000	-01	1	12.5	20	112.1	121	129.3	1754	1879	70

Total Electrical Requirements By Model

Model	Voltage	Total kW	*MCA		*Max Fuse		Water	Drain
			1-Ph	3-PH	1-Ph	3-Ph		
LRPR1- (40 -120HO)	208/120 VAC	5	30	20	50	50	1/2" NPT .07 GPM @ 60 PSI	1/2"PVC; 210 F; <1 GPM Max.
	240/120 VAC	6.6	35	20	50	50		

This Appliance is designed to operate at normal room temperatures; if installed next to an oven or other heat source allow a minimum clearance of 4" to prevent heat transfer. Clearance from combustibles is 0.0" sides and back, For install on non-porous surfaces only

***MCA: Minimum Circuit Ampacity. *Max Fuse: Maximum allowable circuit protector. *Note: Optional Condenser requires separate electrical supply**

IMPORTANT: Your local water conditions may damage your LBC appliance. Failure to properly treat water may result in damage and may void your warranty. Ensure that your water supply meets these minimum specification.

Parameter	Unit	Value
Alkalinity	ppm	22
Aluminium	ppb	17
Calcium	ppm	3.3
Free Chlorine Residual	ppm	0.6

Parameter	Unit	Value
Magnesium	ppm	0.65
pH	s.u.	8.5
Sodium	ppm	8.5
Total Hardness	ppm	11.9

High-Output Roll-In Retarder Proofer

MODEL: LRPR2 -HO Series

INSTALLATION REQUIREMENT

Ships KD requires on-site installation
 208/120 or 240/120 VAC 1 or 3-phase
 Refrigeration system may require installation by a licensed refrigeration technician

1/2" NPT Cold water connection
 3/4" Copper vented drain connection

OPTIONS & ACCESSORIES

Refrigeration Condenser; Stainless Steel Floors

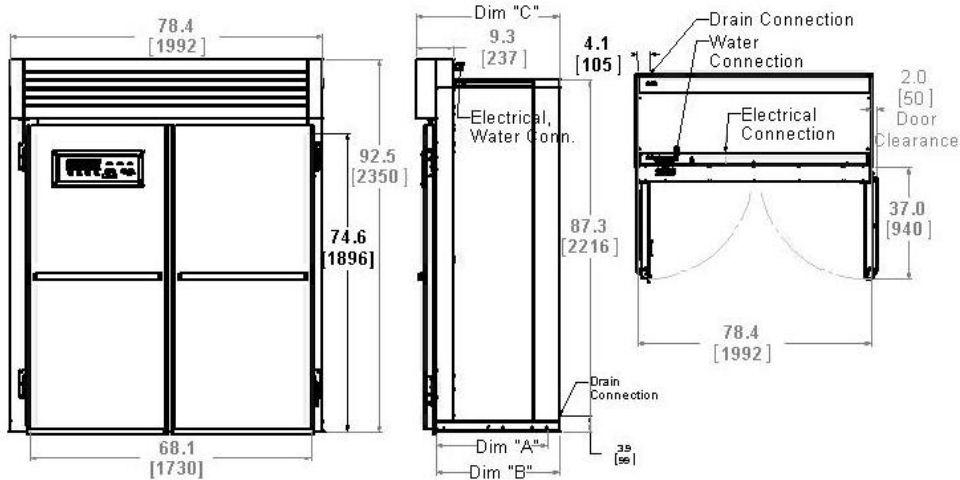

Model	Retarder BTU Rating @ 35 Deg F	Optional Condenser Specs				Depth			Weight		Freight Class
		Part No.	HP	*MCA	*Max Fuse	Internal "A"	Ext. "B"	Over All "C"	Actual	Ship	
LRPR2-30HO	5500	-15	1/2+	8.1	15	26	31	39.3	1100	1200	70
LRPR2-40HO	5500	-15	1/2+	8.1	15	36.1	41.1	49.4	1157	1282	70
LRPR2-50HO	7000	-18	3/4	8.8	15	46.1	51.1	59.4	1329	1454	70
LRPR2-60HO	9000	-01	1	12.5	20	56.1	61.1	69.4	1411	1536	70
LRPR2-70HO	9000	-01	1	12.5	20	66.2	71.2	79.5	1493	1618	70
LRPR2-80HO	11,000	-34	2	15.9	20	76.2	81.2	89.5	1665	1790	70
LRPR2-90HO	11,000	-34	2	15.9	20	87.1	91	99.3	1924	2049	70
LRPR2-100HO	15,000	-24	2.25	17.8	25	97.1	101	109.3	2006	2131	70
LRPR2-110HO	15,000	-24	2.25	17.8	25	107.1	111	119.3	2178	2303	70
LRPR2-120HO	18,000	-24	2.25	17.8	25	117.1	121	129.3	2260	2385	70

Total Electrical Requirements By Model

Model	Voltage	Total kW	*MCA		*Max Fuse		Water	Drain
			1-Ph	3-Ph	1-Ph	3-Ph		
LRPR2-(40HO-80HO)	208/120 VAC	5	30	18	50	50	1/2" NPT .07 GPM @ 60 PSI	1/2" PVC; 210 F; <1 GPM Max.
	240/120 VAC	6.6	34	20	50	50		
LRPR2-(90HO-120HO)	208/120 VAC	10.2	NA	35	NA	60	1/2" NPT .14 GPM @ 60 PSI	1/2" PVC; 210 F; <1 GPM Max.
	240/120 VAC	13.2	NA	39	NA	60		

This Appliance is designed to operate at normal room temperatures; if installed next to an oven or other heat source allow a minimum clearance of 4" to prevent heat transfer. Clearance from combustibles is 0.0" sides and back, For Install on non-porous surfaces only

***MCA: Minimum Circuit Ampacity. *Max Fuse: Maximum allowable circuit protector. *Note: Optional Condenser requires separate electrical supply**

IMPORTANT: Your local water conditions may damage your LBC appliance. Failure to properly treat water may result in damage and may void your warranty. Ensure that your water supply meets these minimum water quality specification.

Parameter	Unit	Value
Alkalinity	ppm	22
Aluminium	ppb	17
Calcium	ppm	3.3
Free Chlorine Residual	ppm	0.6

Parameter	Unit	Value
Magnesium	ppm	0.65
pH	s.u.	8.5
Sodium	ppm	8.5
Total Hardness	ppm	11.9

High-Output Roll-In Retarder Proofer

MODEL: LRPR3 -HO Series

INSTALLATION REQUIREMENT

Ships KD requires on-site installation
 208/120 or 240/120 VAC 1 or 3-phase

1/2" NPT Cold water connection
 3/4" Copper vented drain connection

Refrigeration system may require installation by a licensed refrigeration technician

OPTIONS & ACCESSORIES

Refrigeration Condenser; Stainless Steel Floors

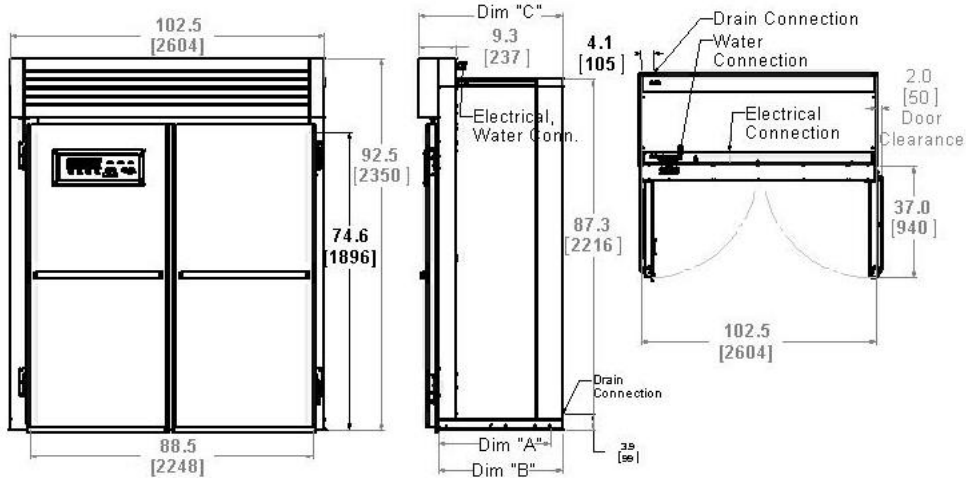

Model	Retarder BTU Rating @ 35 Deg F	Optional Condenser Specs				Depth			Weight		Freight Class
		Part No.	HP	*MCA	*Max Fuse	Internal "A"	Ext. "B"	Over All "C"	Actual	Ship	
LRPR3-30HO	7000	-15	1/2+	8.1	15	26	31	39.3	1172	1472	70
LRPR3-40HO	9000	-18	3/4	8.8	15	36.1	41.1	49.4	1282	1582	70
LRPR3-50HO	9000	-18	3/4	8.8	15	46.1	51.1	59.4	1422	1722	70
LRPR3-60HO	11,000	-01	1	12.5	20	56.1	61.1	69.4	1532	1832	70
LRPR3-70HO	11,000	-01	1	12.5	20	66.2	71.2	79.5	1642	1942	70
LRPR3-80HO	15,000	-34	2	15.9	20	76.2	81.2	89.5	1982	2282	70
LRPR3-90HO	15,000	-34	2	15.9	20	87.1	91	99.3	2269	2569	70
LRPR3-100HO	15,000	-34	2	15.9	20	97.1	101	109.3	2379	2679	70
LRPR3-110HO	19,000	-24	2.25	17.8	25	107.1	111	119.3	2619	2919	70
LRPR3-120HO	19,000	-24	2.25	17.8	25	117.1	121	129.3	2729	3029	70

Total Electrical Requirements By Model

Model	Voltage	Total kW	*MCA		*Max Fuse		Water	Drain
			1-Ph	3-Ph	1-Ph	3-Ph		
LRPR3- (30HO-80HO)	208/120 VAC	5	30	18	50	50	1/2" NPT .07 GPM @ 60 PSI	1/2"PVC; 210 F; <1 GPM Max.
	240/120 VAC	6.6	34	20	50	50		
LRPR3- (90HO-120HO)	208/120 VAC	10.2	NA	35	NA	60	1/2" NPT .14 GPM @ 60 PSI	1/2"PVC; 210 F; <1 GPM Max.
	240/120 VAC	13.2	NA	39	NA	60		

This Appliance is designed to operate at normal room temperatures; if installed next to an oven or other heat source allow a minimum clearance of 4" to prevent heat transfer. Clearance from combustibles is 0.0" sides and back, For Install on non-porous surfaces only

***MCA: Minimum Circuit Ampacity. *Max Fuse: Maximum allowable circuit protector. *Note: Optional Condenser requires separate electrical supply**

IMPORTANT: Your local water conditions may damage your LBC appliance. Failure to properly treat water may result in damage and may void your warranty. Ensure that your water supply meets these minimum water quality specification.

Parameter	Unit	Value
Alkalinity	ppm	22
Aluminium	ppb	17
Calcium	ppm	3.3
Free Chlorine Residual	ppm	0.6

Parameter	Unit	Value
Magnesium	ppm	0.65
pH	s.u.	8.5
Sodium	ppm	8.5
Total Hardness	ppm	11.9

Conditions of Installation

LBC Bakery Equipment, Inc. shall, for a fee contingent on site location and provided that the conditions of installation are met, provide a factory authorized service agency to installation the LBC Model LRP Roll-in Proofers and LRPR Retarder Proofers.

Before LBC Bakery Equipment, Co. or its authorized agent arrives; the job site must be ready for the installation. If the installation site is not properly prepared or if there are construction delays the customer shall be responsible for all expenses incurred during this delay. All expenses resulting from job delay or extension, for reasons beyond the control of LBC Bakery Equipment Inc., will be the responsibility of the customer. Installation shall be conducted during normal business hours.

This installation is for a single trip. Start-up and training are not included.

CODES and ORDINANCES

IN ALL CASES, THE ELCTRICAL, MECHANICAL, UTILITY AND VENTILATION CONNECTIONS MUST MEET ALL FEDERAL, STATE AND LOCAL CODES OR ORDINANCES.

It is the customer's responsibility to:

1. Secure all required permits and meet local code requirements.
2. Ensure that the installation site is cleared and ready for installation before the authorized installer arrives on site. The site shall be smooth and level.
3. Provide all utilities and hook-ups: gas, electrical, water and drains within five (5) feet of the installation location per the specifications provided by LBC Bakery Equipment, Inc.
4. Provided licensed trades person to make the final utility connections.
5. Provide licensed refrigeration technicians to install and charge the refrigeration components.
6. Remove all trash, crates etc. resulting from the installation
7. Provide any peripheral sheet metal work required by local codes or otherwise to bridge the gaps between the ovens and the walls that are caused by wall protrusions.

RECIEVING:

LBC Roll-in Rack proofers and retarder proofers are shipped in a "Knock-down" conditions. The proofer crates vary is size and weight depending on the model purchased.

The crate weights range between 950 LBS and 2500 LBS. Adequate materials handling equipment is required to unload these crates and to move them into the installation area.

DRAINS:

A three quarter (3/4) inch vented drain is required for these proofers. The facility drain should be located within five (5) feet of the proofer drain (consult specification sheet for proofer drain location).

WATER CONNECTIONS:

A one half inch (1/2") copper cold water supply rated at 9 GPM, 40 psi minimum is required for these proofers. The water line should be brought to within five feet (5') preliminarily of the oven site. (consult specification sheet for the location of the water connection). Water treatment may be required, it is strongly suggested that the supply water be tested and treated for impurities.

ELECTRICAL:

Electrical supply for the LBC Bakery Equipment Proofers and Retarder Proofers is a single 208/120 or 240/120 VAC, single or three phase supply. Consult specification sheet for complete electrical requirements.

CODES and ORDINANCES

In all cases, the electrical, mechanical, utility and ventilation connections MUST meet all Federal, State and local codes and or ordinances. LBC is not responsible for these utility connections.

*Additional fees may be levied for return trips to start-up the equipment.
This installation does not include operator training; consult your local sales representative for equipment training*

I have read and understand all of these conditions of installation.

By: _____ Date: _____

<u>WARNING</u>	MOVING PARTS HAZARD. FOLLOW LOCKOUT PROCEDURES BEFORE REMOVING AIR DUCT OR EVAPORATOR FAN GUARDS
<u>WARNING</u>	ELECTRICAL HAZARD BEHIND UPPER FRONT TRIM. FOLLOW LOCKOUT PROCEDURES BEFORE SERVICING.
<u>WARNING</u>	THE LBC BAKERY LRP SERIES PROOFER PRODUCES HUMIDITY WHICH WILL NATURALLY CONDENSE AND ACCUMULATE WATER ON THE INTERIOR FLOOR CAUSING IT TO BECOME SLIPPERY. ADJACENT EXTERIOR FLOOR MAY ALSO BECOME SLIPPERY. USE EXTREME CAUTION WHEN WALKING IN OR AROUND THIS APPLIANCE.
<u>NOTICE</u>	This picture shows an LRP1, LRP2, and LRP3. The LRP1 and some LRP2 models have only one climitizer. Larger models have two climitzers.
<u>DANGER</u>	DO NOT STORE OR USE GASOLINE OR OTHER FLAMMABLE VAPORS OR LIQUIDS IN THE VICINITY OF THIS OR ANY OTHER APPLIANCE.
<u>NOTICE</u>	For best results, always allow your proofer to reach set temperature and humidity before putting product in.
<u>NOTICE</u>	For best results, proof at lower temperatures rather than higher.
<u>NOTICE</u>	To dry proof: Set humidity to the lowest setting (either 45% or less). At this setting the humidity generator is turned off and will not produce humidity.
<u>NOTICE</u>	When the actual humidity is less than 46% display will show 45. When the actual humidity is higher than 45%, display will show the actual humidity.
<u>NOTICE</u>	Service on this or any other LBC BAKERY equipment must be performed by qualified personnel only. Consult your authorized service agency directory or call the factory at 1-888-722-5686 or go to WWW.LBCBAKERY.COM for the service agent nearest you.
<u>NOTICE</u>	The LRP1 has hinges mounted on the right jamb only.
<u>CAUTION</u>	THIS APPLIANCE, WHEN INSTALLED, MUST BE ELECTRICALLY GROUNDED IN ACCORDANCE WITH LOCAL CODES, OR IN THE ABSENCE OF LOCAL CODES, WITH THE NATIONAL ELECTRICAL CODE, ANSI/NFPA 70-1996.



CAUTION

FOR INSTALLATION IN CANADA THE INSTALLATION MUST BE IN ACCORDANCE WITH CAN/CGA-B149.1&2 OF THE INSTALLATION CODE, AND LOCAL CODES WHERE APPLICABLE. ALL ELECTRIC WIRING MUST BE IN ACCORDANCE WITH THE CURRENT CANADIAN ELECTRICAL CODE, C22.1 PART 1. GROUNDING THIS APPLIANCE MUST CONFORM TO CANADIAN ELECTRICAL CODE, CSA C22.2.

**WARNING**

INSTALLATION OF THE UNIT MUST BE DONE BY PERSONNEL QUALIFIED TO WORK WITH ELECTRICITY AND PLUMBING. IMPROPER INSTALLATION CAN CAUSE INJURY TO PERSONNEL AND /OR DAMAGE TO EQUIPMENT. UNIT MUST BE INSTALLED IN ACCORDANCE WITH ALL APPLICABLE CODES

**WARNING**

MOVING PARTS HAZARD. FOLLOW LOCKOUT PROCEDURES BEFORE REMOVING AIR DUCT OR EVAPORATOR FAN GUARDS

**WARNING**

ELECTRICAL HAZARD BEHIND UPPER FRONT TRIM. FOLLOW LOCKOUT PROCEDURES BEFORE SERVICING.

**WARNING**

THE LBC BAKERY LRP SERIES PROOFER PRODUCES HUMIDITY WHICH WILL NATURALLY CONDENSE AND ACCUMULATE WATER ON THE INTERIOR FLOOR CAUSING IT TO BECOME SLIPPERY. ADJACENT EXTERIOR FLOOR MAY ALSO BECOME SLIPPERY. USE EXTREME CAUTION WHEN WALKING IN OR AROUND THIS APPLIANCE.



Lockout Procedure

1. Announce lockout to other personnel.
2. Turn both heat and control power off at main panel.
3. Clear unit of all personnel.
4. Test lockout by turning power switch on and observing if control panel displays or fan(s) come on. Check heater circuit with voltmeter.
5. Perform necessary repairs or tests.
6. Clear unit of personnel before restarting.
7. Turn power on at main panel.
8. Announce unit is "on" to other personnel.

Safety Precautions

LBC Bakery Equipment hereby disclaims any and all responsibility for injury, damage, loss or other claim that may occur to person or property from improper alteration, modification, addition, operation, maintenance or service, whether it be mechanical, electrical, fuel, operator, motor or otherwise, which may occur from such improper alteration, modification, addition, operation, maintenance or service to this piece of equipment.

Safety Considerations

Your LBC Bakery LRP Proofer is manufactured to rigid standards. This equipment is E.T.L. listed and meets safety and sanitation standards.

The presence of safety equipment control and interlocks on an appliance and attendant components of installation cannot, in and of themselves, assure absolute safety of operation. Diligent, capable, well trained operators and maintenance personnel, as well as proper programs of operation and maintenance, are essential to the safe and reliable operation of this appliance.

- A. The **responsibility of the manufacturer** is to supply suitable, comprehensive instructions and recommendations for the operation and maintenance of the appliance.
- B. All operations, maintenance and repair of the subject units must be performed by properly trained and qualified personnel, and all such operations, maintenance and repair must be performed in a diligent manner. It is the **responsibility of the owner/operator** to insure proper training and diligence of any person coming into contact with either the subject units or the output (product, exhaust or otherwise) of the subject units. It is the **responsibility of the owner/operator** to ensure that the subject units are installed and operated in accordance with OSHA Standard 1910.263.
- C. A regular periodic program of cleaning, inspection and maintenance must be established and comprehensive maintenance records maintained. It is the **sole responsibility of the user** to establish, schedule and enforce the frequency and scope of these programs in keeping with recommended practice and with due consideration given to actual operating conditions.
- D. The appliance must be operated within limits which will not exceed the working limits of any component within the appliance as a whole.

WARNING

THE LBC BAKERY LRP SERIES PROOFER PRODUCES HUMIDITY WHICH WILL NATURALLY CONDENSE AND ACCUMULATE WATER ON THE INTERIOR FLOOR CAUSING IT TO BECOME SLIPPERY. ADJACENT EXTERIOR FLOOR MAY ALSO BECOME SLIPPERY. USE EXTREME CAUTION WHEN WALKING IN OR AROUND THIS APPLIANCE.



NOTICE

Service on this or any other LBC BAKERY equipment must be performed by qualified personnel only. Consult your authorized service agency directory or call the factory at 1-888-722-5686 or go to WWW.LBCBAKERY.COM for the service agency nearest you.



NOTE: ON UNITS WITH FLOOR ONLY!

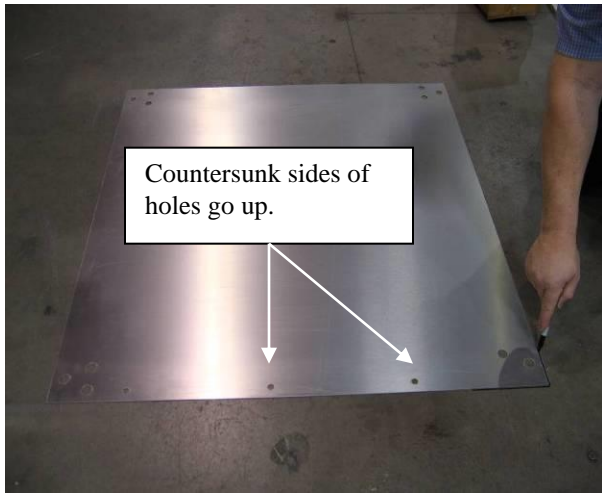

Place floor onto prepared surface and mark position. Take into consideration drain location.

Note: Tile that may come loose over time should be removed.



Place floor adhesive onto floor and spread with provided trowel. Seal bottom with a good continuous bead along edge before setting into final resting position. Apply weight to floor while adhesive sets.

Note: Row of 3/8” holes is front of floor. Countersunk sides of holes go up.



Drill holes with rotary drill and install anchors in front row (and middle row if applicable). Drill 10MM diameter hole 1 1/2” deep and remove all dust from hole. Do not drill too deep. Install anchor with provided insert tool.

Note: If concrete subfloor has additional layer of softer leveling slag and anchors do not hold, a longer anchor bolt may be necessary.

Do not install anchors at edges or corners at this time.

One good blow is better than many small taps when installing anchors.

Note: Units without Stainless Floor start here.

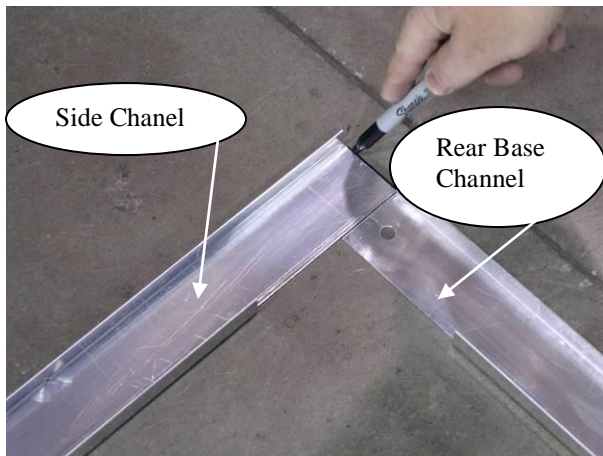

Place wall base channels as pictured. Outside dimensions should match Specification Sheet. Mark outside edge with non permanent marker.

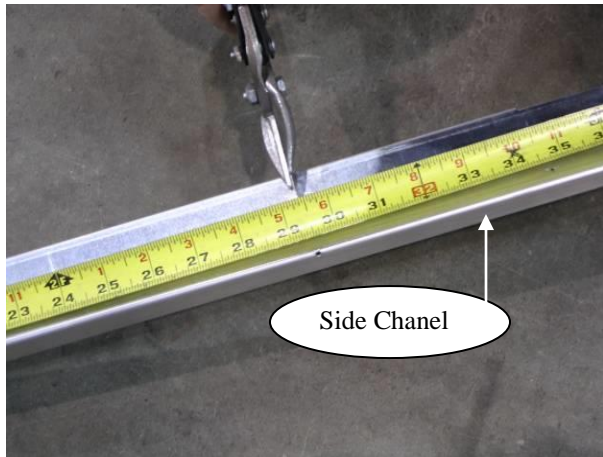

Each proofer is supplied with enough track to install a 120" deep proofer.

Holes in side channel indicate cutting points for base channels. Cut side channels short enough to leave front corners exposed.

You may need both channel pieces depending on the size of the proofer.

No base channel on door side of proofer.



Optional: Seal base channels with small amount of silicone to stop leaks from developing at bottom of unit.

Press base channel to floor.

Note: Recheck dimensions to insure wall panels fit into track. Once silicone dries, base channels are hard to move. See Spec. Sheet.

See wall panel location Chart 1 for panel placement.

Chart 1, Panel locations

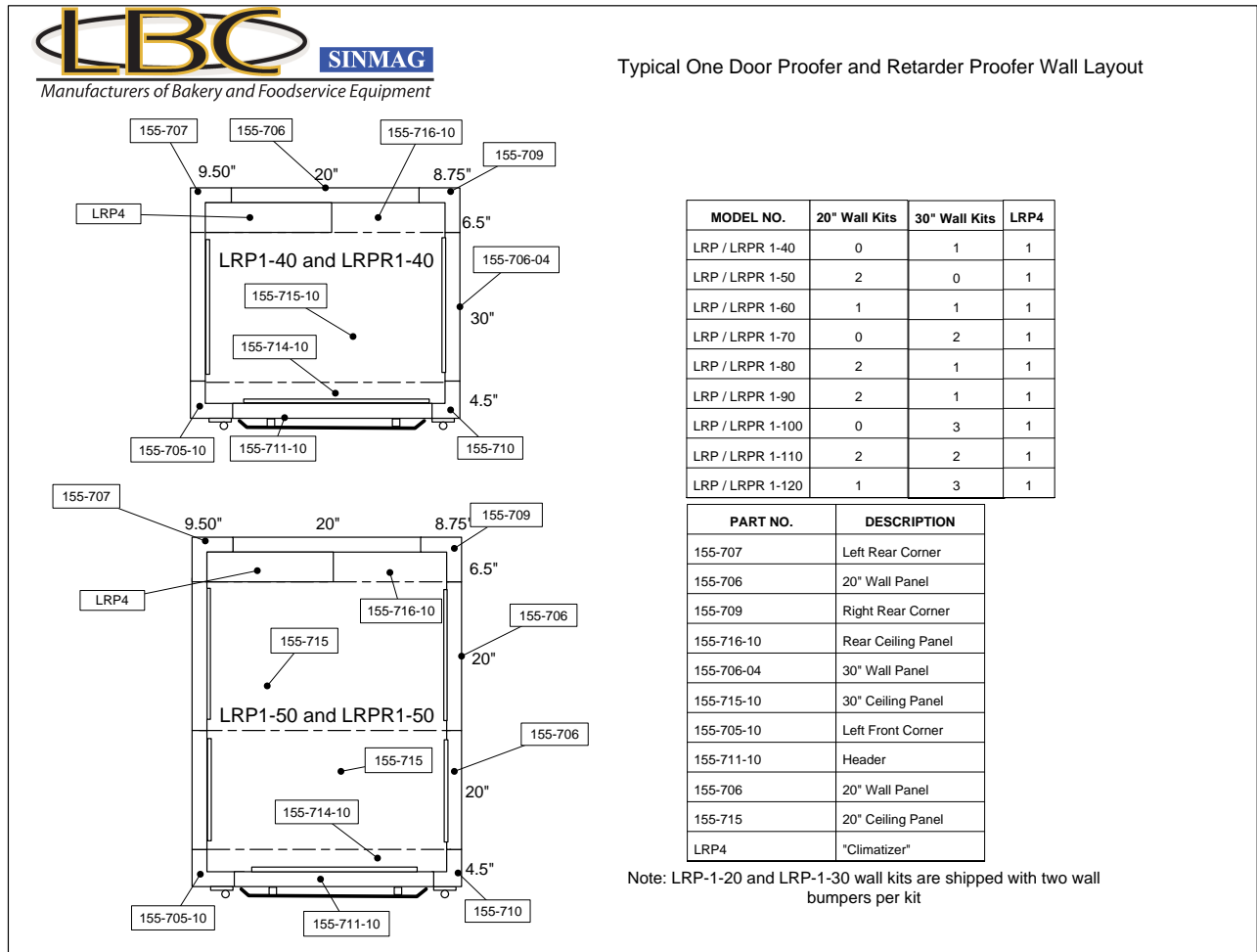

Typical Two-Door Proofer and Retarder Proofer Wall Layouts

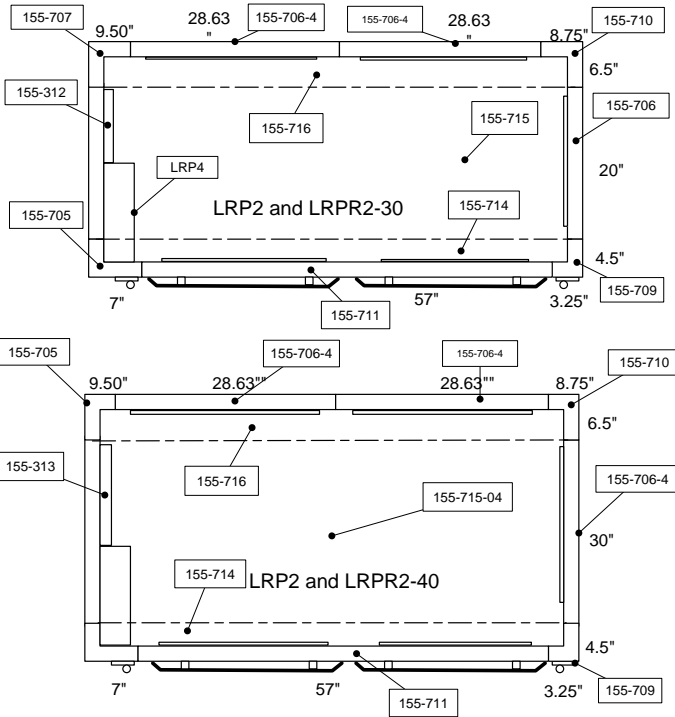

Note: Wall Panel Kits include one wall bumper and one drain line bumper.

MODEL NO.	20" Wall Kits	30" Wall Kits	LRP4
LRPR / LRP2S-30	1	0	1
LRPR / LRP2S-40	0	1	1
LRPR / LRP2S-50	2	0	1
LRPR / LRP2S-60	1	1	1
LRPR / LRPR 2-70	0	2	1
LRPR / LRP2S-80	2	1	1
LRPR / LRP2S-90	1	2	2
LRPR / LRP2S-100	0	3	2
LRPR / LRP2S-110	2	2	2
LRPR / LRP2S-120	1	3	2

PART NO.	DESCRIPTION
155-707	Left Rear Corner
155-710	Right Rear Corner
155-716	Rear Ceiling Panel
155-706	20" Wall Panel
155-715	20" Ceiling Panel
155-705	Left Front Corner
155-711	Header
155-709	Right Front Corner
155-714	Front Ceiling Panel
155-706-4	30" Wall Panel
155-715-04	30" Ceiling Panel
LRP4	"Climatizer"
155-312	20" Drain Bumper
155-313	30" Drain Bumper

Typical Two-Door Pass-Through Proofer and Retarder Proofer Wall Layouts

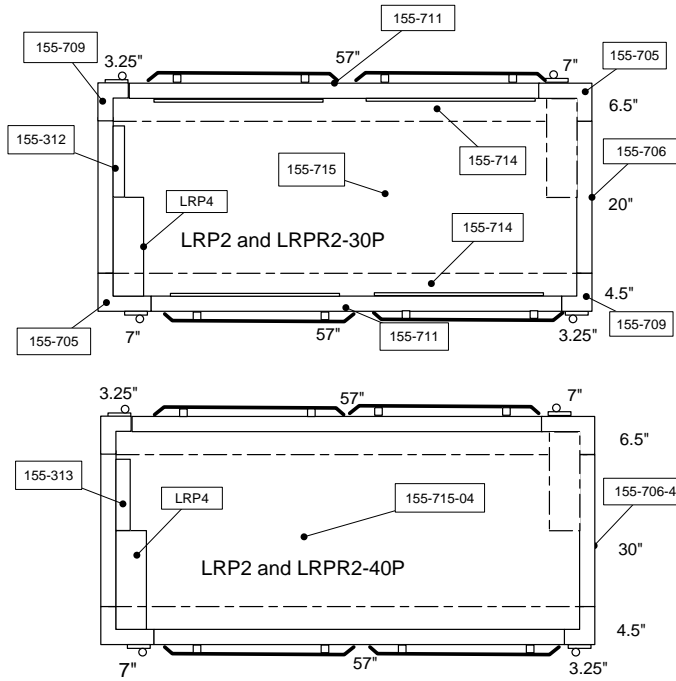

IMPORTANT NOTE:
LRP4 Climatizer can only be mounted in the Left Rear or Right Front Corner on Pass-Through Models
Drain hole must be field drilled

MODEL NO.	20" Wall Kits	30" Wall Kits	LRP4
LRPR / LRP2S-30	1	0	1
LRPR / LRP2S-40	0	1	1
LRPR / LRP2S-50	2	0	1
LRPR / LRP2S-60	1	1	1
LRPR / LRPR 2-70	0	2	1
LRPR / LRP2S-80	2	1	1
LRPR / LRP2S-90	1	2	2
LRPR / LRP2S-100	0	3	2
LRPR / LRP2S-110	2	2	2
LRPR / LRP2S-120	1	3	2

PART NO.	DESCRIPTION
155-707	Left Rear Corner
155-710	Right Rear Corner
155-706	20" Wall Panel
155-715	20" Ceiling Panel
155-705	Left Front Corner
155-711	Header
155-709	Right Front Corner
155-714	Front Ceiling Panel
155-706-4	30" Wall Panel
155-715-04	30" Ceiling Panel
LRP4	"Climatizer"
155-312	20" Drain Bumper
155-313	30" Drain Bumper

Typical Two-Door Triple Wide Proofer and Retarder Proofer Wall Layouts

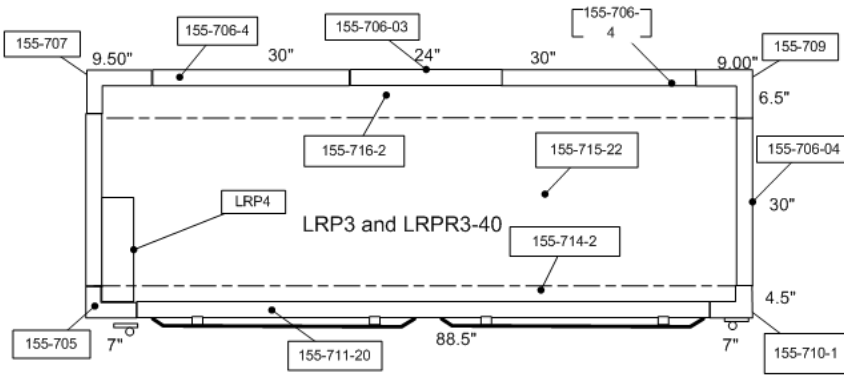
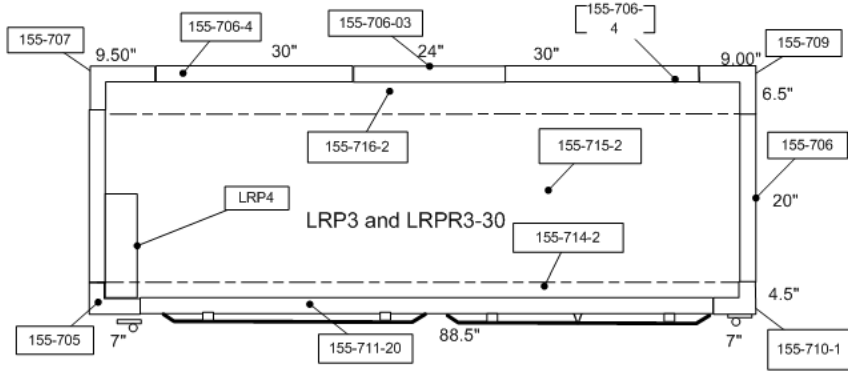

MODEL NO.	16" Wall	20" Wall	30" Wall	LRP4
LRP / LRPR 3-30		1	0	1
LRP / LRPR 3-40		0	1	1
LRP / LRPR 3-50		2	0	1
LRP / LRPR 3-60		1	1	1
LRP / LRPR 3-70		0	2	1
LRP / LRPR 3-80		2	1	1
LRP / LRPR 3-90		1	2	2
LRP / LRPR 3-100		0	3	2
LRP / LRPR 3-110		2	2	2
LRP / LRPR 3-120		1	3	2

PART NO.	DESCRIPTION
155-707	Left Rear Corner
155-706-04	30" Wall Panel
155-715-22	30" Ceiling Panel
155-709	Right Rear Corner
155-716-2	Rear Ceiling Panel
155-706	20" Wall Panel
155-715-2	20" Ceiling Panel
155-705	Left Front Corner
155-711-20	Header
155-709	Right Front Corner
155-714-2	Front Ceiling Panel
155-706-02	16" Wall Panel
155-715-3	16" Ceiling Panel
LRP4	"Climatizer"

**Typical Two-Door Triple Wide Pass Through Proofer and Retarder
Proofer Wall Layouts**

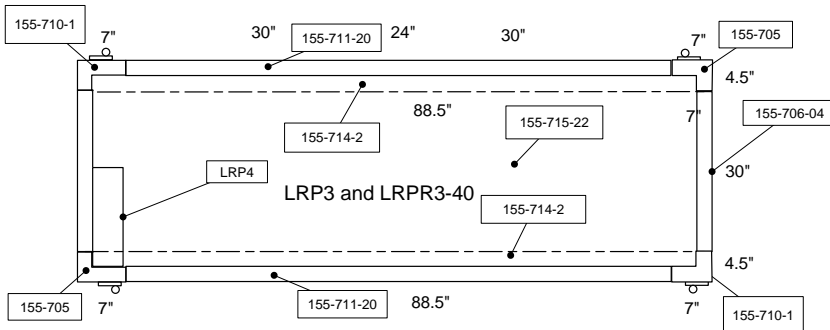
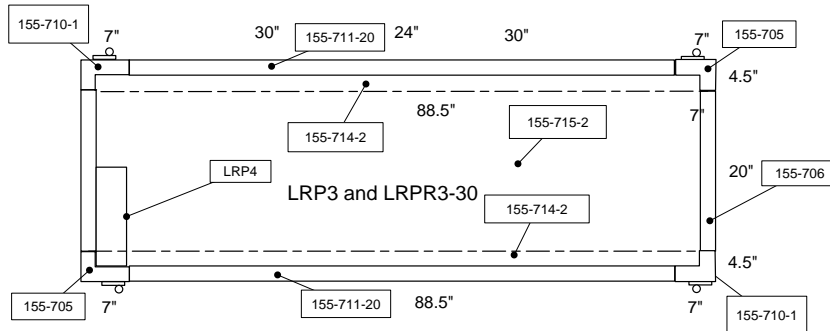

IMPORTANT NOTE:
LRP4 Climatizer can only be mounted in the Left Rear or
Right Front Corner on Pass-Through Models
Drain hole must be field drilled

MODEL NO.	16" Wall	20" Wall	30" Wall	LRP4
LRP / LRPR 3-30		1	0	1
LRP / LRPR 3-40		0	1	1
LRP / LRPR 3-50		2	0	1
LRP / LRPR 3-60		1	1	1
LRP / LRPR 3-70		0	2	1
LRP / LRPR 3-80		2	1	1
LRP / LRPR 3-90		1	2	2
LRP / LRPR 3-100		0	3	2
LRP / LRPR 3-110		2	2	2
LRP / LRPR 3-120		1	3	2

**NOTE: 16" Panel may be substituted
to meet space requirements**

PART NO.	DESCRIPTION
155-705	Left Corner
155-710-1	Right Corner
155-706-04	30" Wall Panel
155-715-22	30" Ceiling Panel
155-706	20" Wall Panel
155-715-2	20" Ceiling Panel
155-711-20	Header
155-714-2	Front Ceiling Panel
155-706-02	16" Wall Panel
155-715-3	16" Ceiling Panel
LRP4	"Climatizer"

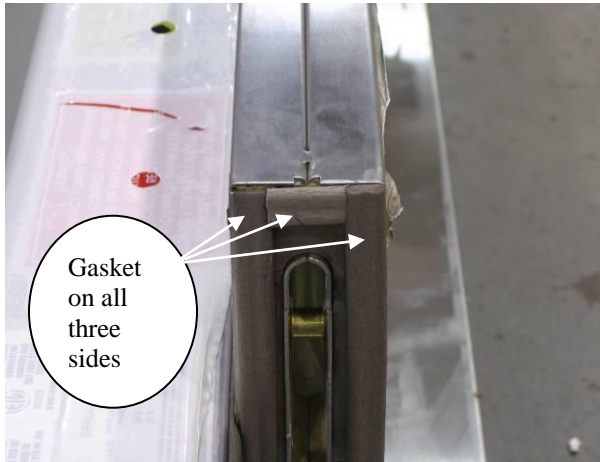

Place header assembly on floor upside down.

Note: When installing Panel Assemblies inspect to insure gasket material is installed along all edges.

Header panel requires gasket material as shown. If gasket is missing moisture will migrate into panel sections.

All three sides pictured have grey gasket material installed.

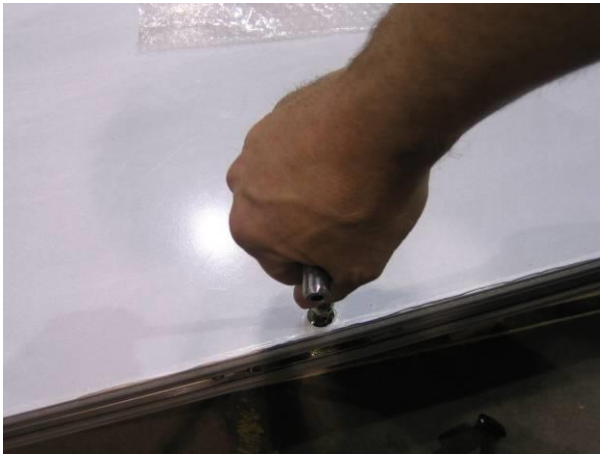

Note: When locking a cam it may be necessary to first rotate cam all the way back until a positive click is heard. This will ready the cam for locking. DO NOT OVER TIGHTEN! Over tightening will damage the cam.

Once the cam is reset it will not click again until you attempt to lock the cam into its receiver, or onto a screwdriver shaft.

If cam will not reset or lock, lubricate cam with WD-40® or equivalent and work cam open and closed until it resets and locks.

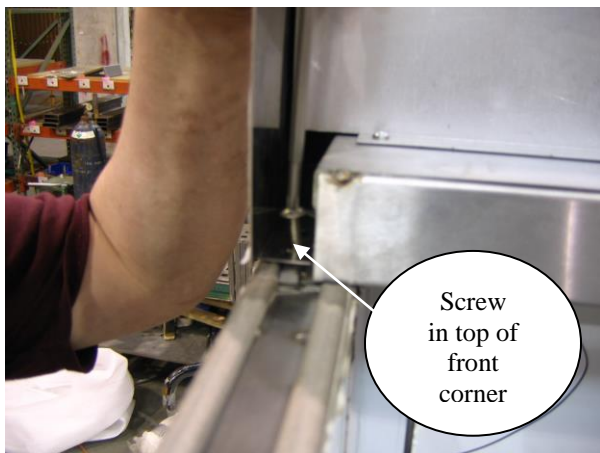

If front corners have two screws installed, remove two screws from each front corner panel top. These screws will later be reused to secure the valance.



Install Front Corner panel and tighten cams.

Note: Do not over tighten.

A positive click should be felt when cam is locked. If cam will not click into locked position do not over tighten. Lube cam and work until cam locks. See note on previous page.

Flip front assembly over.



Reinstall screw in top of each front corner panel securing valance.

Shim Part # 155-249



Note: Check sides for gasket material on all sides!

Install one left and one right side to front. Place front with side panels into base track, then plumb front corners. To plumb place level on front as pictured in center photo. Cams may need to be repositioned to achieve plumb. **Shim (Part #155-249) front to achieve level, left to right only.** Shims, pictured below level, are provided with unit.

See Chart 1 on page 13 for correct panel placements. Continue to add side panels 90° in relation to ground. **Keep the front plumb and level.** Shim sides as needed. Allow top of panels to be uneven if necessary to maintain to maintain 90 ° angles from ground. **Drain holes on back corners go to bottom back of unit.**

ASSEMBLY CONT'D



Align front as necessary, then mark rear base channel position.

Remove rear corners.

Note: Drain holes on back corners go to bottom back as pictured.



Drill holes with rotary drill and install anchors in rear base channel. Drill 10MM diameter hole 1 1/2" deep and remove all dust from hole. Do not drill too deep. Install anchor with provided insert tool.

Note: If concrete subfloor has additional layer of softer leveling slag and anchors do not hold, a longer anchor bolts may be necessary.



Install remaining panel assemblies maintaining 90° angles.

ASSEMBLY CONT'D



Note: Make sure all hinge mounting screws are tight.

Hang door(s). Use a 30"x 1"x 4" board (as shown) or a dolly to lift door and move into position.

Make sure both hinges seat and hinge washers are present.

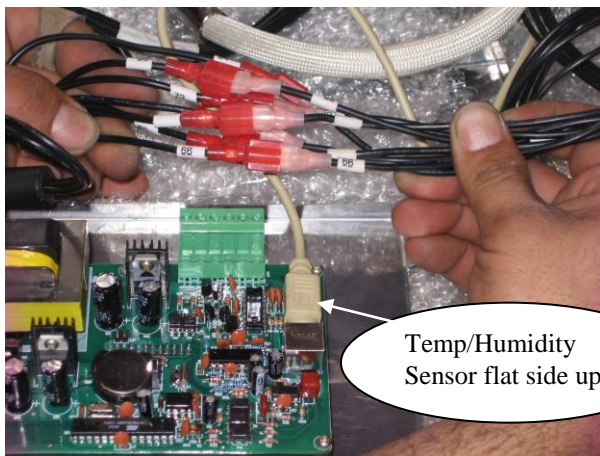

On model # LRP-2 sensor will come preinstalled inside header.

On all models push connector end through hole in door and connect to control as pictured.

Plug temperature / humidity sensor into board with **flat side of connector up** as pictured.

Plug connectors from control panel into connectors from door. Verify wire #'s on both sides of connector correspond.

Check to assure all wires in connector seat tightly together.



Screw control panel into door using supplied screws. Bend tabs as necessary to align with center set of holes.

Bezel may need to be bent slightly to create tight fit to panel.

Install bezel as shown using supplied screws.
Optional: A small bead of silicone around bezel will seal bezel.

ASSEMBLY CONT'D



Install door, handles and bumpers onto door(s).

Install conduit mounting brackets and gaskets onto valance and door.



Apply caulk to backside of high limit mounting bracket and install high limit and bracket.



On LRP1 and LRP2 models Install **250V** light bulb, gasket, and globe.

New LRP3 models will have Florescent Lamps pre-installed.

Note: If 120V bulbs are installed fuses will blow.

ASSEMBLY CONT'D

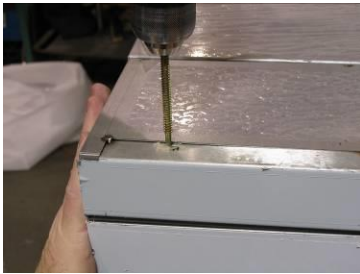

Note: Inspect ceiling panels for gasket material on bottom.

Install ceiling panels flush with sides.

Align back corners and install one screw. Recheck door alignment and plumb of front. Shim front with part # 155-249 as needed to obtain plumb.

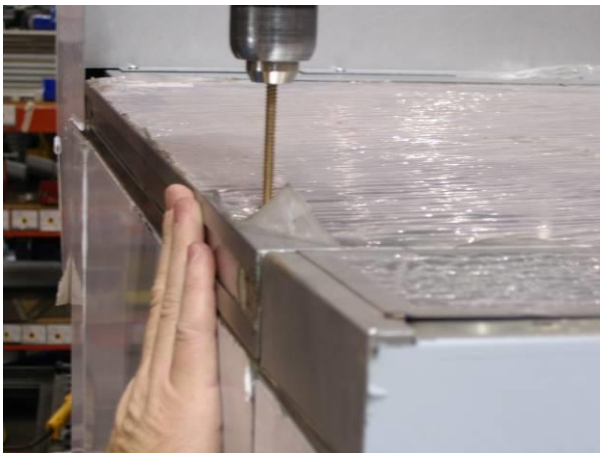

Align ceiling panels flush with side and install remaining 3" hex head ceiling screws.

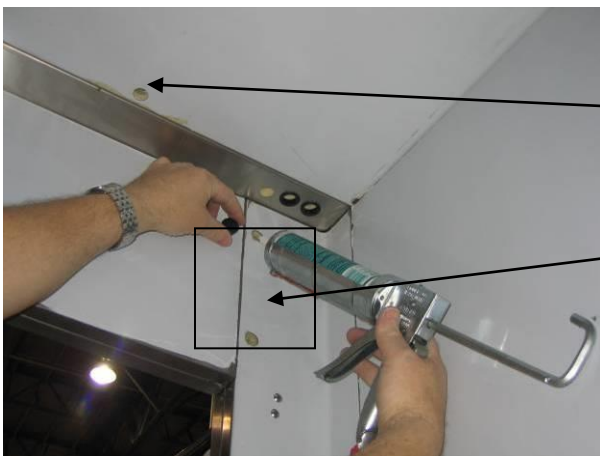

Peel all vinyl from inside unit.

Fill cam holes with caulk and install plugs.

Check for gaps and **caulk header to top seam** and all other openings.

Note: If unit is a pass through leave out 2 upper corner plugs in corner without climitizer; instead, install stiffener plate Part #155-323 in corners without climatizer installed. Stiffener plate should join corner and header and be secured with supplied stainless steel hardware.

ASSEMBLY CONT'D

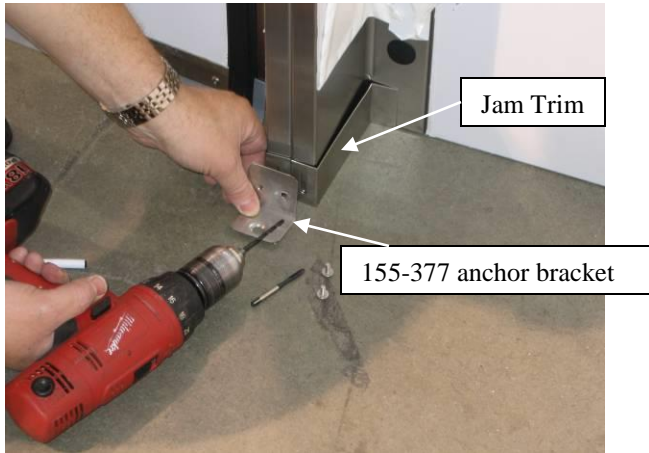

Install left and right jam trim, and anchor bracket to unit. Drill and tap bracket mounting holes. If necessary, use 2" X 2" steel shims (155-377-1) to extend bracket-jam connection if anchor is over tile grout or other obstruction.

Secure only with Stainless Steel screws provided.

Anchor brackets to floor; see page 16 for anchor instructions.



Caulk base channels to floor inside and out.

Install rear corners behind base molding.

Cut to fit and install base trim over corners.

Drill trim mounting holes with provided drill bit. Lube holes and tap with provided tap. Secure with provided **Stainless Steel** machine screws.



Install top trim part #155-745 using provided screws.

Do not over tighten.

ASSEMBLY CONT'D

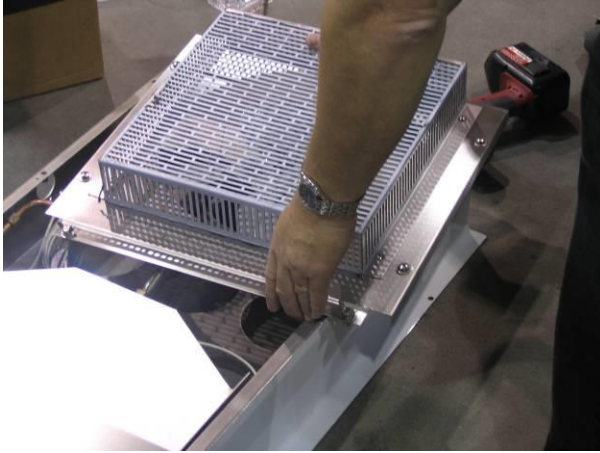

Remove fan guard, cover, and water line from air duct assembly.

Determine duct location.

Single Door Proofers - Back wall tight to left side.

Double Door Proofers - Left side wall tight to front.

Double Duct Proofers - Mount first duct on left side wall tight to front. Mount second duct on same side tight to back.

LRP3 Models – Ducts can be mounted on left or right side determine by drain location.

Remove climatizer mounting screws from applicable corner.

NOTE: Hold Climatizer as tight to top as possible when drilling holes to prevent gap at top causing uneven proofing!

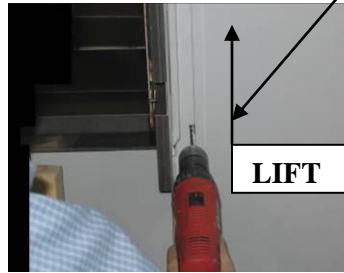

Hold duct in position using 17 ½" chalk block to support weight while holding **tight to side and top**. Shim chalk block as necessary to align left side mounting holes.

CAUTION! Hold duct in place tight to top until all mounting screws are inserted.

Insert top two screws. Bottom left screw may need to be remarked, drilled, and tapped as pictured on right

Drill and tap duct right hand mounting holes with drill bit and tap provided. Secure with provided **Stainless Steel** machine screws in 6 places.



Route wires through black bushing in ceiling.

Note: Protect your wires. Make sure wires are away from moving parts and plastic bushings are installed into header.

Insert water supply line, ferrule, and nut through ceiling..

ASSEMBLY CONT'D



LRP1 Models Only

Install water line pointing towards rear of proofer.

Make sure water line is long enough to reach back of unit.

ASSEMBLY CONT'D



Install 90° fitting to water line pointing down into unit.

Install climatizer water line into 90° fitting; this water line ships with climatizer and has a 90° bend that points into nozzle assembly.

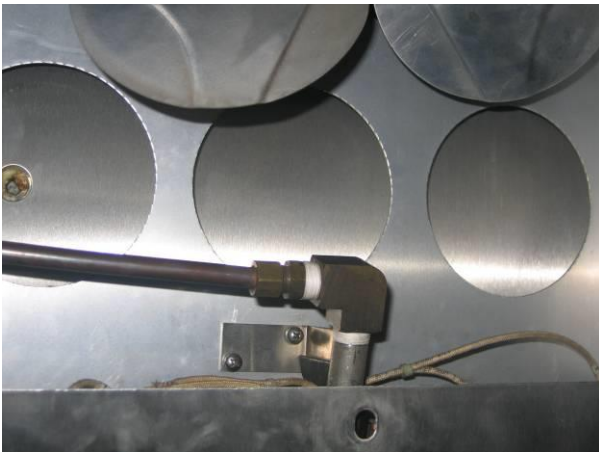

Install water line into nozzle assembly.

Reinstall covers onto climatizer.

Note: Silicone all water line and electrical holes leading into proofer.



LRP2 Models Only

Install climatizer water line into 90° fitting; this water line ships with climatizer and has a 90° bend that points into nozzle assembly.

See above step; install water line into nozzle assembly.

ASSEMBLY CONT'D

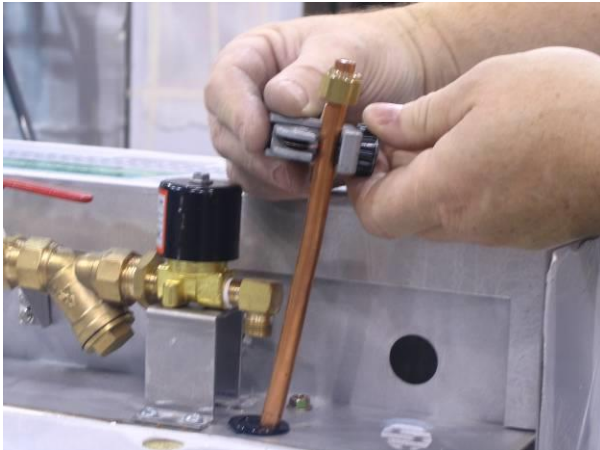

LRP2 with 2 Climatizers Only

Cut climatizer water line below ferrule and nut, leaving room on short piece to add T fitting as pictured below.

This may be necessary on some LRP3 models also.



Install T fitting as pictured with 90° facing rear climatizer assembly.



Install water line pointing towards rear of proofer.

Make sure water line is long enough to reach back of unit.

Go to top of page 22. Install line to climatizer.

ASSEMBLY CONT'D

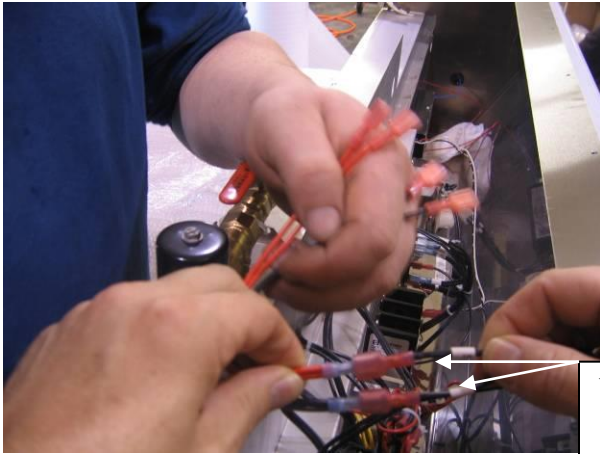

LRP with 2 Climatizers Only

If climatizers are to be mounted on right hand side remove pictured fan jumper wires and relocate jumper to right hand side of additional harness mounted inside header. This harness is only used when climatizers are mounted on the right. It brings power from the left side of the header to the right side of the header. Connect wires 10 and 16 disconnected from fan jumper wires to left side of this additional harness.

Wires 10 and 16

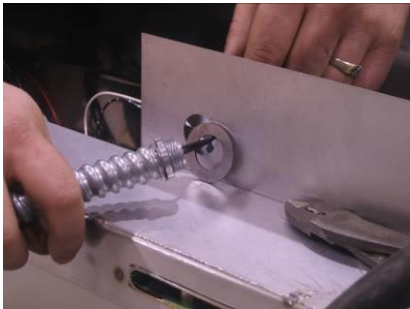

Pass Through Models Only.

Install rear light jumper harness to front header as pictured.

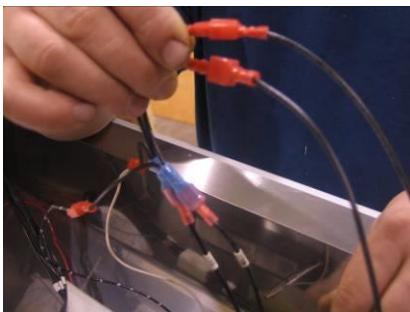

Pass Through Models Only.

Connect light jumper wires at front header to wires 10 and 16 and to rear header ballast.

Pass Through Models Only.

Use self drilling screws to attach harness to rear header as pictured.



Pass Through Models Only.

Install Angle Bumper to protect Climatizer assembly from racks using supplied stainless sheet metal screws.

ASSEMBLY CONT'D

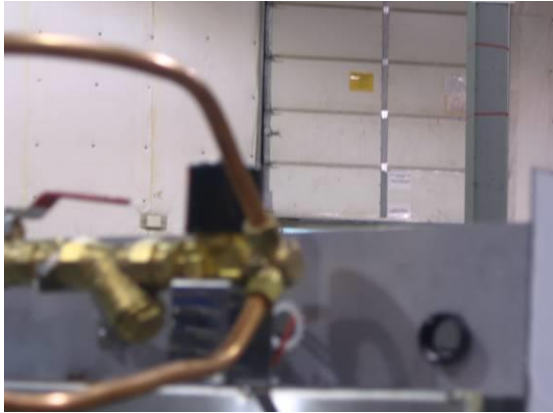

LRP3 Models

Install 2 water lines as pictured. Shape one water line to rear climatizer and one water line to front climatizer.

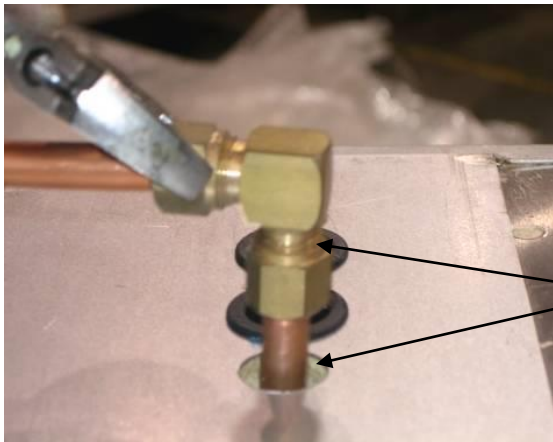

Install 90° fitting to water line pointing down into unit.

Install climatizer water line into 90° fitting; this water line ships with climatizer and has a 90° bend that points into nozzle assembly.

Note: After wiring elements and plumbing, silicone all wire and plumbing access holes to top of proofer.

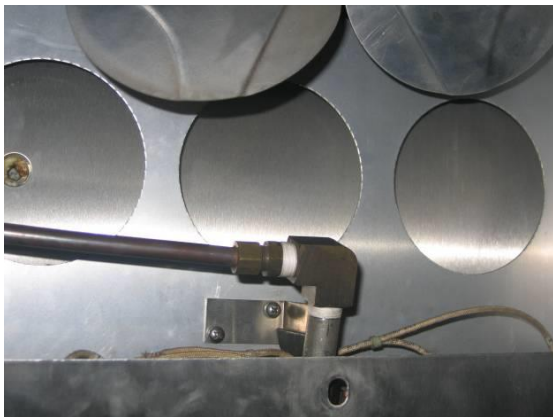

Install water line into nozzle assembly.

Reinstall covers onto climatizer.

Note: After wiring elements and plumbing, silicone all water line and electrical holes leading into proofer.

ASSEMBLY CONT'D

Silicone openings after wiring and plumbing are complete.

Detail B

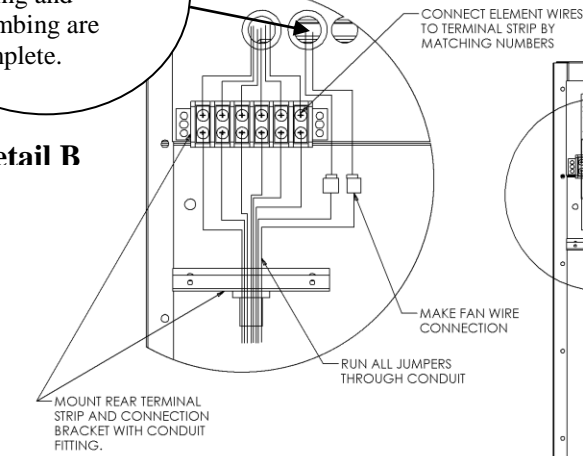

RIN WIRES THROUGH CONDUIT INTO COMPONENT AREA.

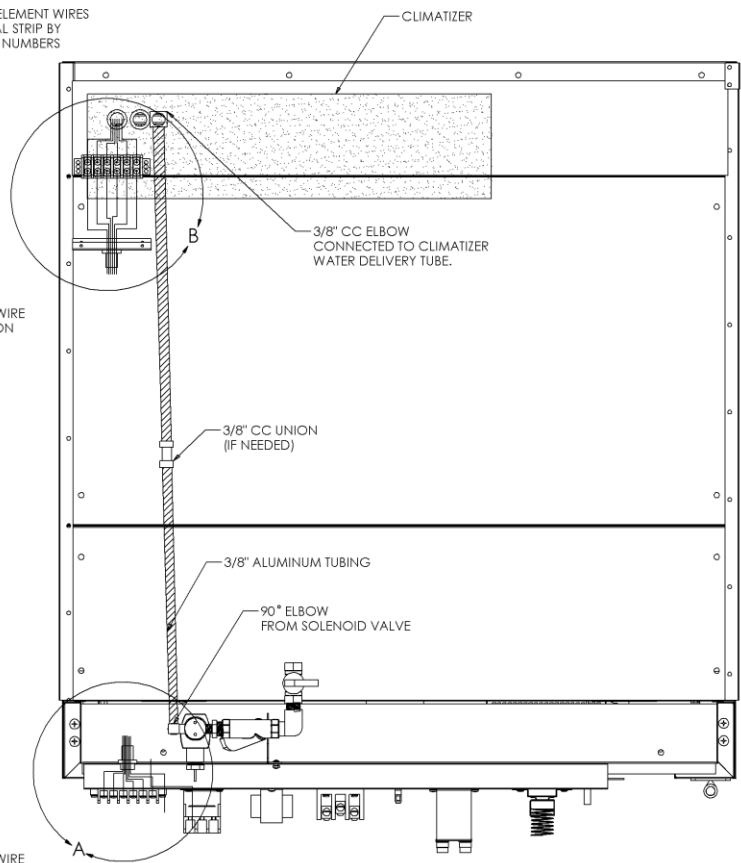
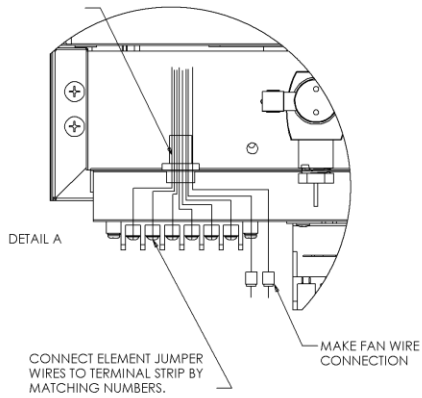

Silicone openings



For Model LRP3 With right hand climatizers only. Additional harness is mounted inside header to bring power from contactors and wires 10 and 16 (fan power wires) to right side of header.. All connections at rear are made at terminal block as drawn in above Detail B. Push all wires through Front Electrical Cover into header. All front connections made at terminal block inside header as drawn above in Detail A.

Water Connection

Incoming water connection is made at a ½" NPT Fitting provided at the top of the unit behind the valance.

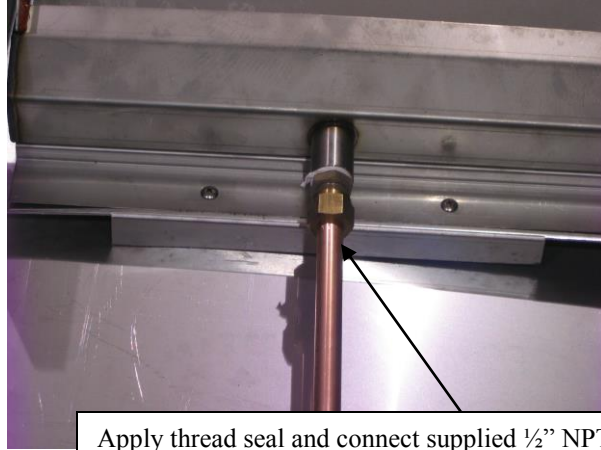
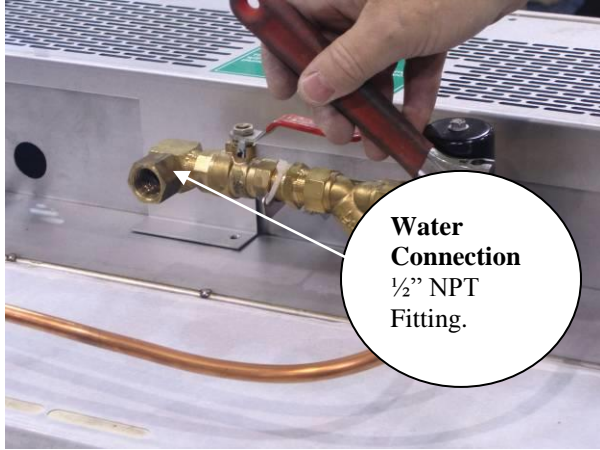

Apply thread seal and connect supplied ½" NPT to 5/8" OD compression connector to drip pan assembly at bottom of climatizer.

Install 5/8" OD Drain Line (**not supplied**) at compression fitting. Drain must be vented for proper drainage.

NOTE: LRPR Retarder Proofer evaporator drain(s) will be supplied (PVC) and tie into Climatizer drain line.

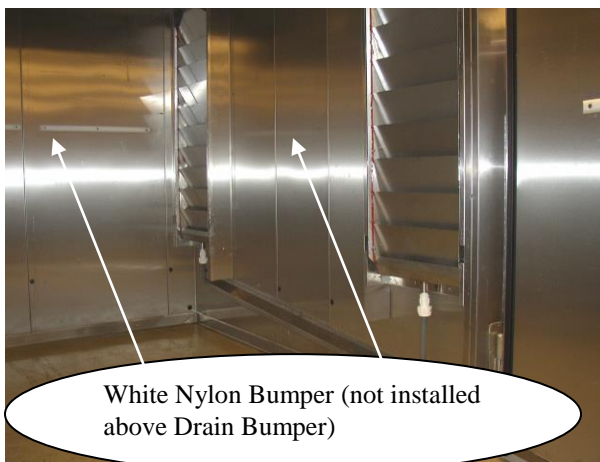
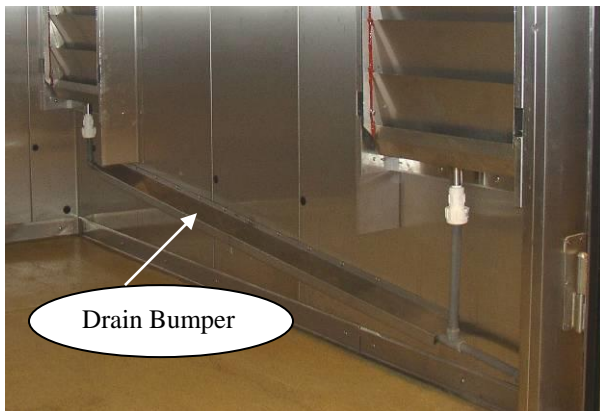

Bumpers

Drain Bumper

Temporarily install drain bumpers, mark mounting holes. Remove drain bumper, drill mounting holes with provided drill bit. Lube holes and tap with provided tap. Secure with provided **Stainless Steel** machine screws.

Note: White Nylon Bumper Guard not needed on wall above drain bumper.

Install White Bumpers on climatizer(s) and remaining sides of proofer with provided **Stainless Steel** screws. **Do not install above Drain Bumper.**

Step 11

Wire Cover channel installation for heat boxes

- Caulk wires into the hole in the ceiling panel to form a vapor barrier.
- If only one heat box is present, no conduit or relay connection box is necessary

Illustration 11

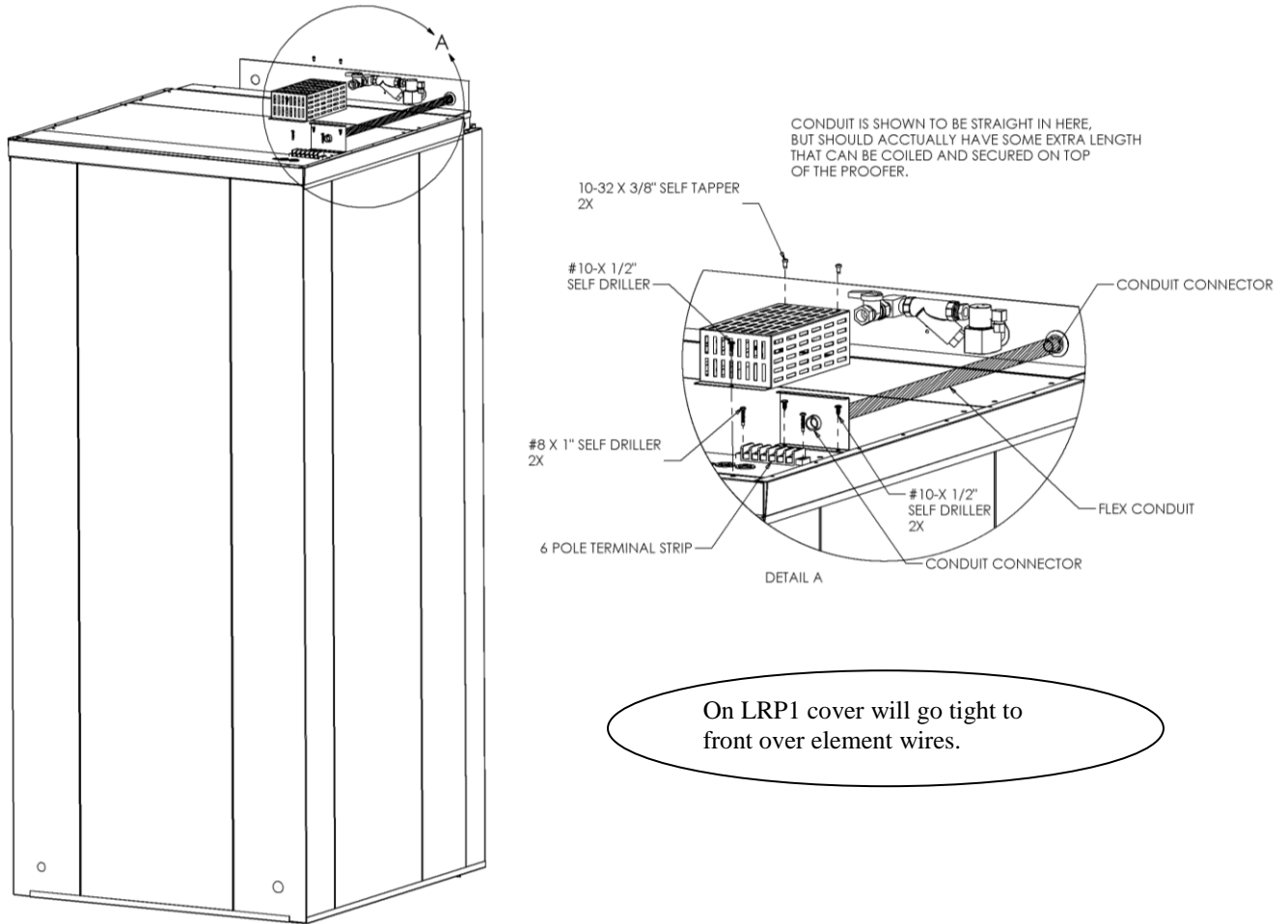

CAUTION

THIS APPLIANCE, WHEN INSTALLED, MUST BE ELECTRICALLY GROUNDED IN ACCORDANCE WITH LOCAL CODES, OR IN THE ABSENCE OF LOCAL CODES, WITH THE NATIONAL ELECTRICAL CODE, ANSI/NFPA 70-1996.

**CAUTION**

FOR INSTALLATION IN CANADA THE INSTALLATION MUST BE IN ACCORDANCE WITH CAN/CGA-B149.1&2 OF THE INSTALLATION CODE, AND LOCAL CODES WHERE APPLICABLE. ALL ELECTRIC WIRING MUST BE IN ACCORDANCE WITH THE CURRENT CANADIAN ELECTRICAL CODE, C22.1 PART 1. GROUNDING THIS APPLIANCE MUST CONFORM TO CANADIAN ELECTRICAL CODE, CSA C22.2.

**WARNING**

INSTALLATION OF THE UNIT MUST BE DONE BY PERSONNEL QUALIFIED TO WORK WITH ELECTRICITY AND PLUMBING. IMPROPER INSTALLATION CAN CAUSE INJURY TO PERSONNEL AND /OR DAMAGE TO EQUIPMENT. UNIT MUST BE INSTALLED IN ACCORDANCE WITH ALL APPLICABLE CODES

**Electrical Connection**

Electrical connection can be made through a 3/4" knockout in the back of the valence. A three pole terminal block has been provided on the component assembly for power connection. Please refer to wiring diagram for phasing. Refer to Spec sheets for electrical circuit requirements.

On units with two contactors make element connections at top of contactors.

On units with one contactor make element connections on terminal strip (not shown).

See Spec Sheets for circuit size.
 Single phase connections on L1 and L2 Only.
 Contact LBC for connection instructions if neutral is not available.
 "NC" is no connection.

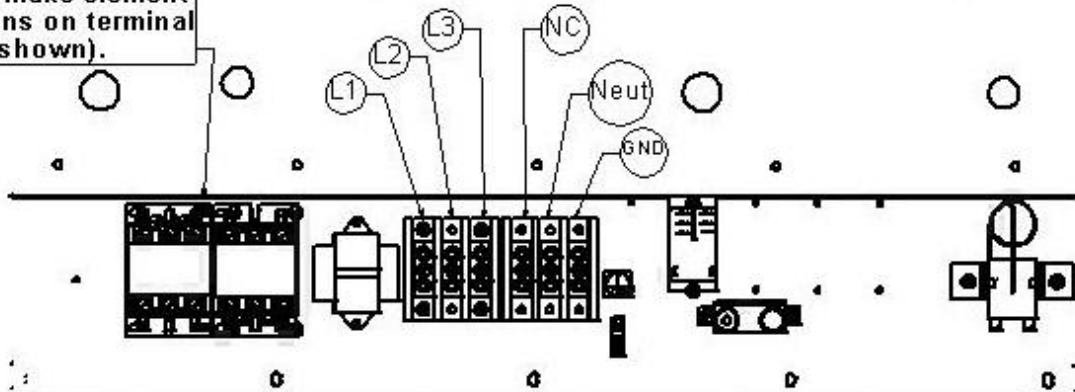

Element Wire Connection	A	B	C	D	E	F
Single Phase	1	2,3	NC	4,6	5	NC
Three Phase	1	2	3	4	5	6

Single-Phase and Three-Phase Power Connections for All LRP Models

Note: Retarder/Proofers may include Condensers which require a separate electrical supply connection.

See Spec Sheets

Retarders/Proofers Only

Power Supply to Retarder/Proofer

208/240 VAC, 60, 3 PH, 20 A, or 1 PH, 40 A,
(Units with 1 Climatizer),
or
208/240, 60, 3 PH, 40A, or 1 PH, 70 A,
(Units with 2 Climatizers)

Power Supply to Condenser

120 VAC, 60, 20 A, 1/3 hp, or
208/240 VAC, 60, 1 PH, 15 A, 1/2 to 3/4 hp, or
208/240 VAC, 1 PH, 20 A, 1 hp to 2 hp

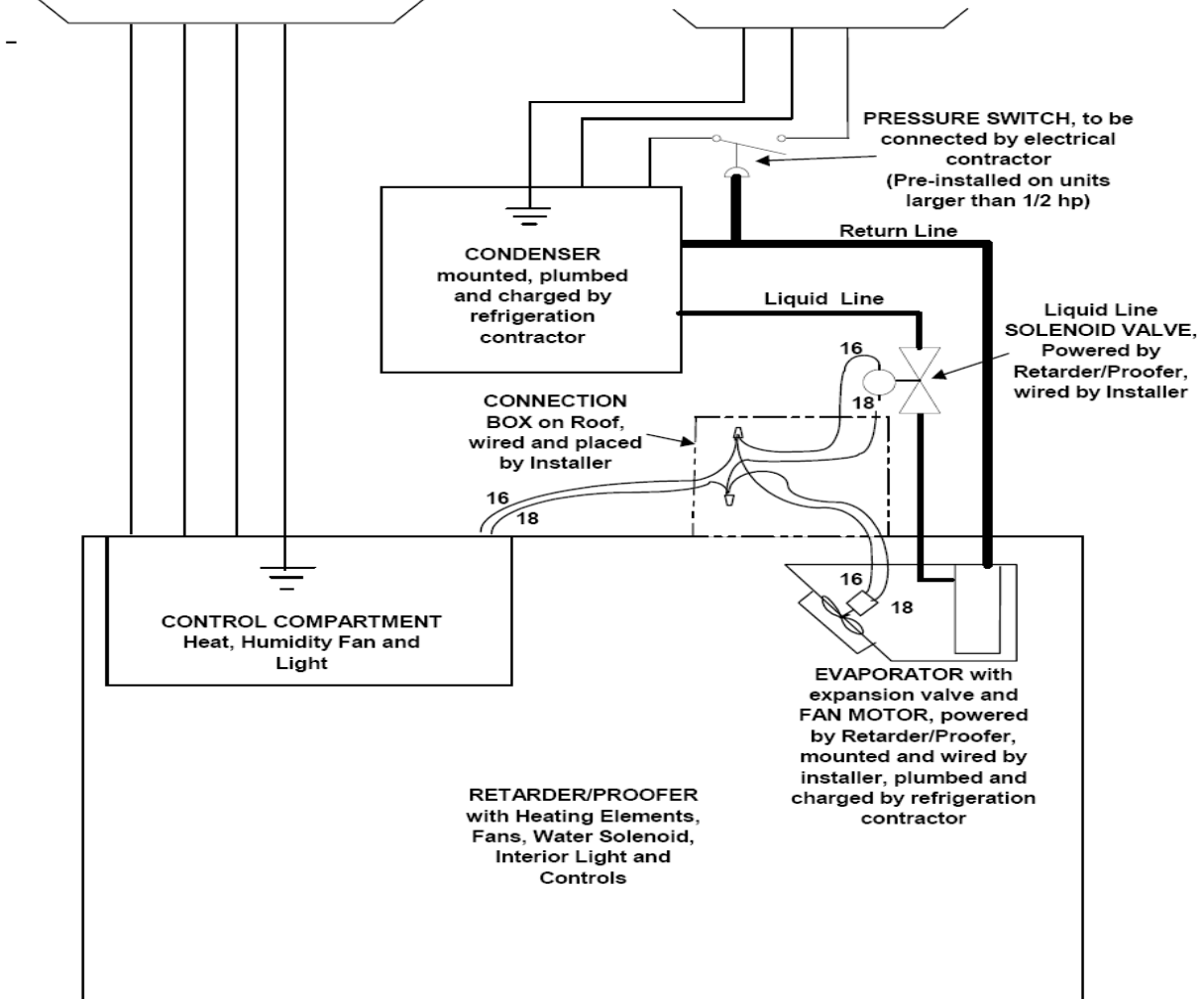

Retarder/Proofer Refrigeration System
Installation and Connection

REFRIGERATION CYCLE

NOTE: THIS IS A GENERAL DRAWING FOR REFERENCE
ACTUAL PARTS MAY VARY IN APPEARANCE

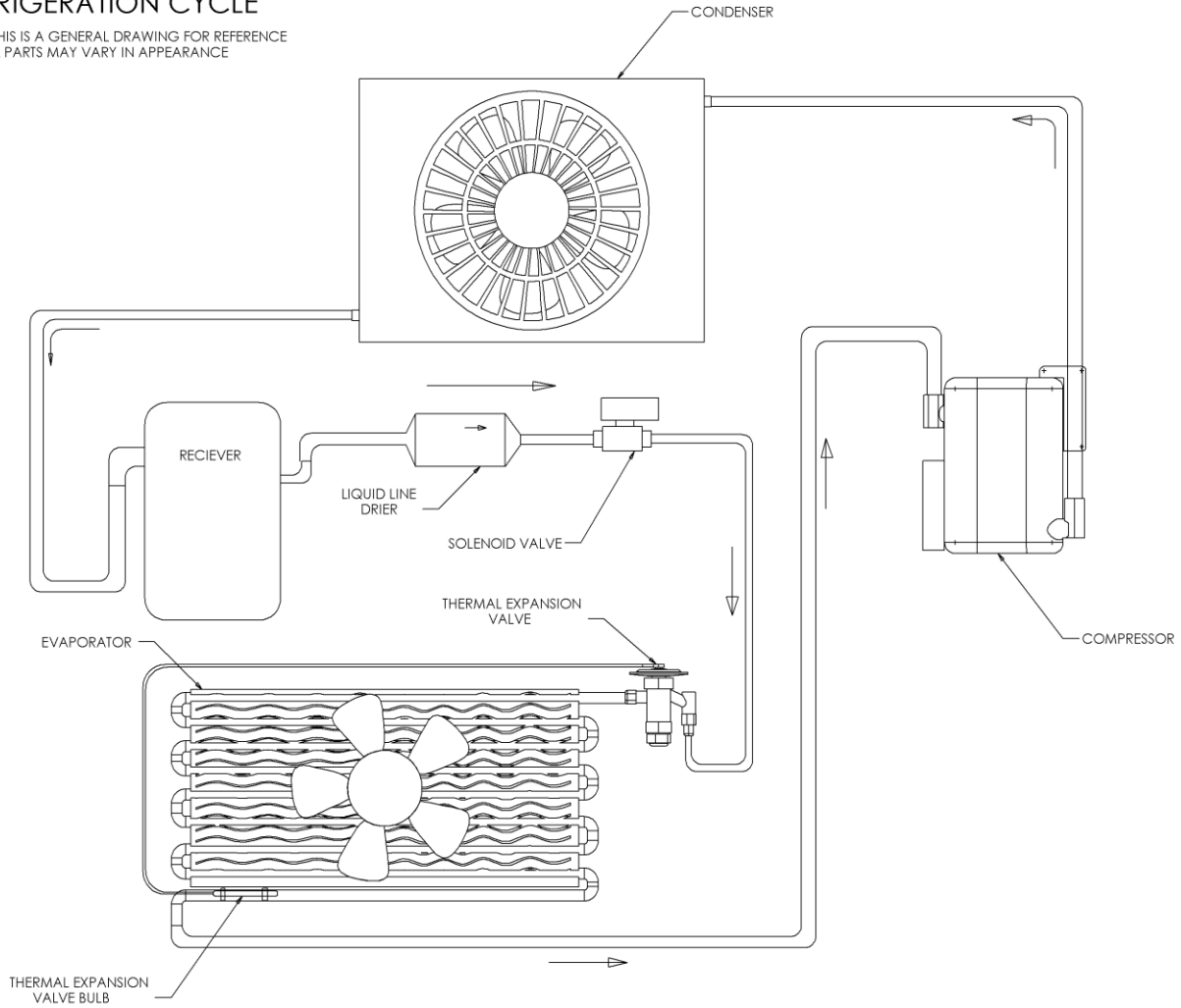

NOTICE

A qualified & licensed refrigeration mechanic must perform connection, evaluation & charging of refrigeration lines. The condenser unit, if supplied, is charged, but additional refrigerant may be required.



Instructions for Installer: 10 Steps

Note: Assemble the proofer per the LRP installation instructions provided. Some models are available with optional pre-assembled and charged refrigeration. If you have a pre-assembled and charged system, skip to part 5 and continue by connecting solenoid and fan wires to the header. Also note that the condenser is powered by a separate electrical supply. See the spec sheet for required circuit information.

Part 1:

Remove the evaporator(s) from the shipping container. Remove the cover with the fan installed and inspect the evaporator, noting any dents or loose screws. Repair as needed. Inspect the evaporator tubing for holes leaks or unsoldered joints. (It is easier to do this inspection before you mount the evaporators.)

Part 2:

Refer to the table page 49 for the correct location of the evaporator in the cabinet.

Note: A 12" minimum air gap to front wall is necessary for good circulation of air before temp probe. See Table: Evaporator Locations.

Hold the evaporator (less the cover) against the ceiling and mark the location of the 4 mounting holes. Drill these holes with a 1/4" drill through the ceiling. Mount the evaporator(s) with the 1/4" x 3" stainless steel screws, washers, lock washers and nuts provided. Locate the approximate location of the fan connection inside the evaporator(s). Drill a 3/8" hole through the evaporator(s) and through the ceiling at this location. Install the 3/8" plastic busing in these holes to protect the electrical wires.

Note: Mount the evaporators so that discharge air flows toward the door(s) to insure that the thermostat will function properly. Some models can only be mounted with the discharge to the side.

Retarder/Proofers Only

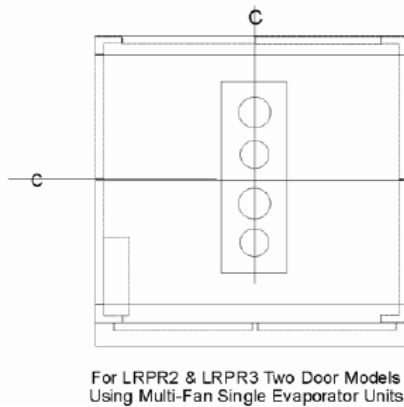
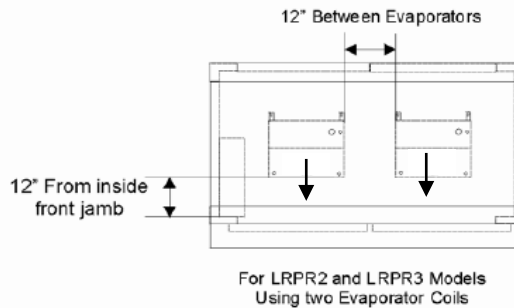
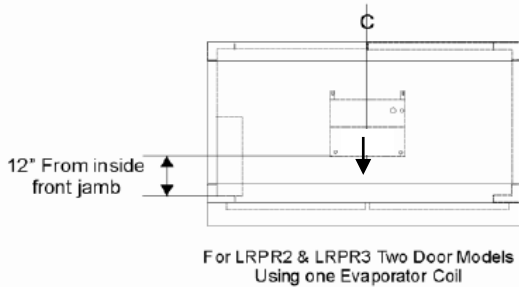
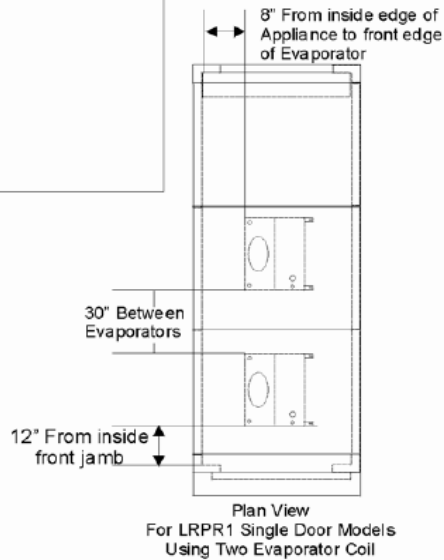
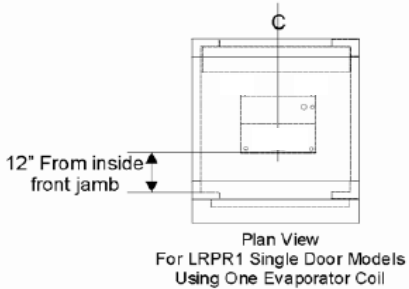
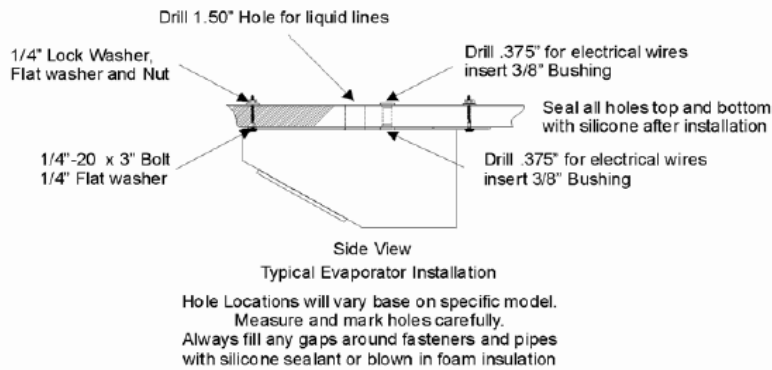

Note: Air flow from the evaporators must flow toward the door of the retarder/proofer in order for the temperature control to work properly.

Part 3:

Locate the flexible electrical conduit and connectors provided with the retarder kit. Install one connector in the available conduit hole in the back of the header assembly.

Locate (do not attach at this time) the ventilated electrical connection box over the 3/8" diameter hole(s) in ceiling with the bushing(s) installed. Install conduit connectors in these boxes.

Note: If there are two evaporators provided, a box will need to be installed over each electrical connection hole.

Stretch the electrical conduit from the header to the first box. Cut conduit to size and install between header and first box. Repeat this procedure between the first and second box if applicable. Locate the liquid line solenoid valve provided with the retarder kit and install a conduit connector. Stretch a reasonable length of conduit (approximately 48") from the last connection box to the liquid line solenoid valve. Connect conduit between the last box and the liquid line solenoid valve. See "Fig: Wire covers and conduit installation for evaporator and condenser" on next page.

Part 4:

Feed the evaporator fan wires through the ceiling and onto the top of the retarder/proofer. Be sure that these wires are secured in the evaporator so that normal servicing will not put tension on any wire going through the ceiling. Feed the 18 gauge wire provided through the conduit and connect to wires 16 and 18 in the header. Connect one wire from each evaporator fan and one wire from the liquid line solenoid to wire 16 in each electrical box cover. Connect wire 18 to the other evaporator fan wire in each connection box and at the liquid line solenoid. See drawing # 61124-08 on page 51.

Note: Evaporator fans and the liquid line solenoid will both function at the same time.

Part 5:

Screw both ends of the electrical connection boxes to the ceiling. Reinstall the cover on the liquid line solenoid connection box. Reinstall the cover on the header. See "Fig: Wire covers and conduit installation for evaporator and condenser" on next page.

Retarder/Proofers Only

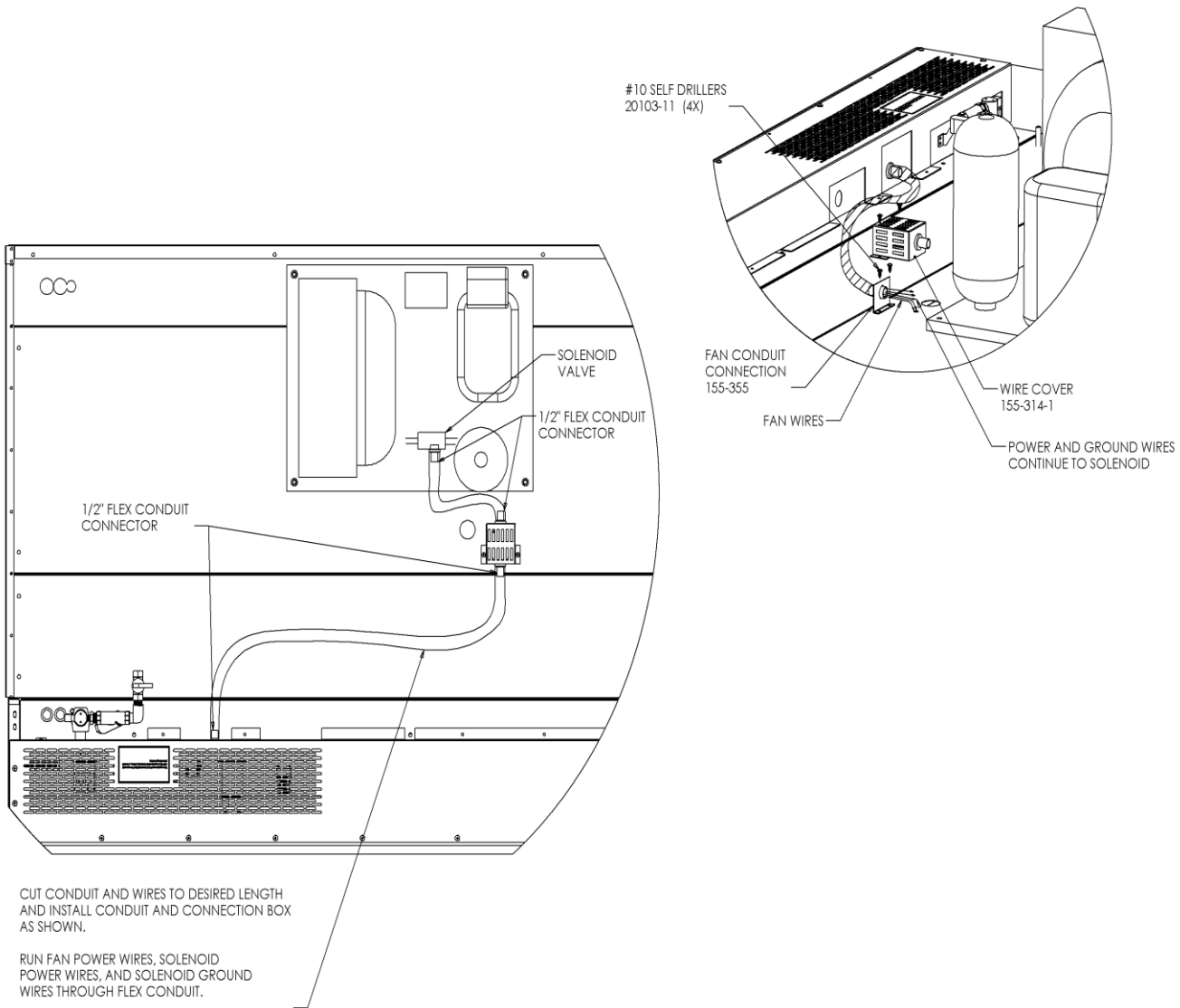

Fig: Wire covers and conduit installation for evaporator and condenser.

Retarder/Proofers Only

Part 6:

Units with local condensing unit only:

Place the condensing unit on top of the retarder proofer. Locate the condenser so that the refrigeration lines will easily connect with the evaporator inside the retarder/proofer. Be sure that there is ample space around the condenser to allow airflow at temperatures less than 90° F. Allow adequate space for air discharge to prevent air discharge from recycling through the fan. Anchor the condenser to the top of the retarder/proofer through the mounting holes in the base.

MOUNT CONDENSING UNIT

MOUNT CONDENSING UNIT ON TOP OF PROOF BOX. LOCATE SO THAT FAN IS CONSTANTLY DRAWING IN CLEAN, COOL AIR. ALSO ALLOW ADEQUATE SPACE FOR AIR DISCHARGE TO PREVENT AIR FROM RECYCLING THROUGH THE FAN.

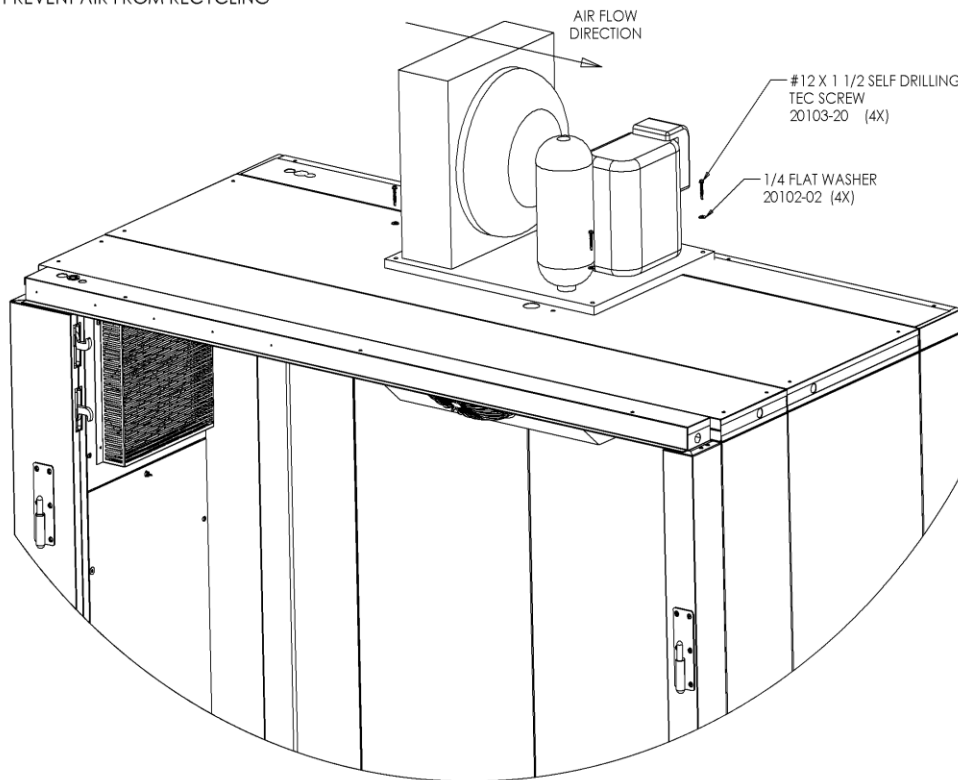

Part 7:

Collect the expansion valve(s), liquid line dryer, pressure switch (if provided; check parts list), and this manual. Please have them available for the refrigeration technician.

Note: The refrigeration system must be assembled, tested, charged and certified by a certified refrigeration technician.

Have electrician hook up power. Please partner with the electrician to make sure he has information in this manual necessary to hook up power to proofer/retarder and compressor.

Note: The electrical connections must be made by a certified electrician.

Part 8:

Hook up drain. **Note: Install union at evaporator to allow for servicing.**

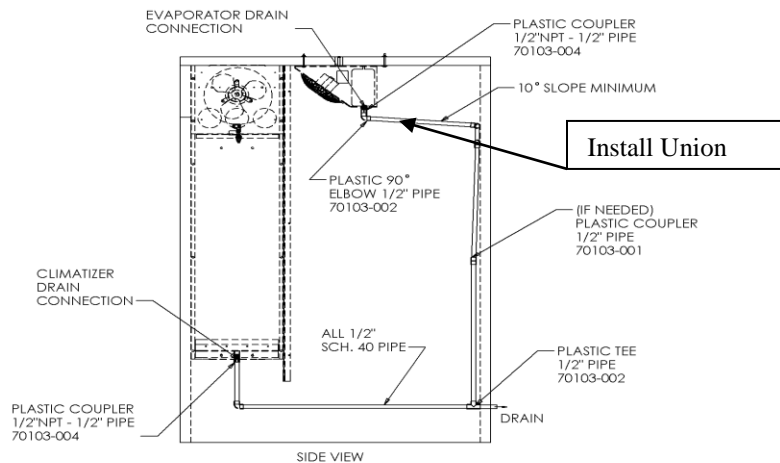
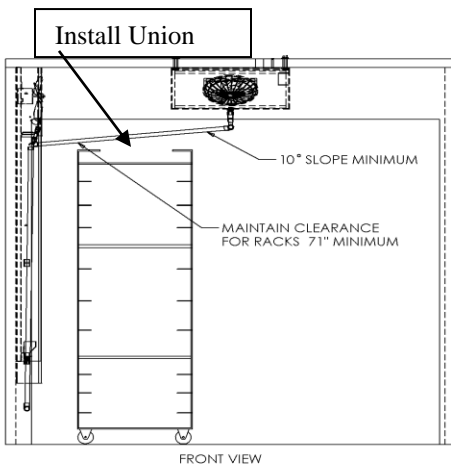

PLUMBING EXAMPLE

NOT ALL APPLICATIONS WILL FOLLOW THIS ILLUSTRATION EXACTLY. THERE MAY BE MORE DIRECT PATHS TO CONNECT THE EVAPORATOR DRAIN LINE INTO THE CLIMATIZER DRAIN LINE. ALSO SEE ILLUSTRATION WITH TWO CLIMATIZERS AND TWO EVAPORATORS. IT IS BEST TO PLAN ENTIRE PLUMBING ROUTE BEFORE STARTING.

IMPORTANT: KEEP IN MIND THE HEIGHT OF THE RACKS. KEEP A MINIMUM OF 71" TO THE BOTTOM OF DRAIN PIPES THAT MAY INTERFERE WITH RACKS. ON HORIZONTAL RUNNING LINES, MAINTAIN A 10° SLOPE MINIMUM. THIS MAY HAVE TO BE COMPROMIZED SLIGHTLY TO KEEP RACK CLEARANCE.

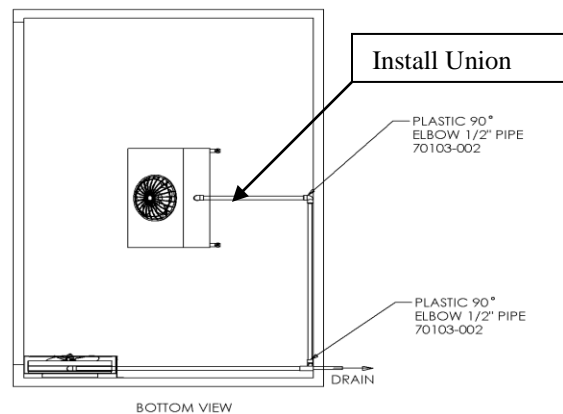

Part 9:

Before the refrigeration system is connected and charged, check electrical power, water and drain to the retarder/proofer. Turn on the retarder proofer and operate in normal operation (see proofer installation instructions and installation start-up and training check list).

Turn on the “Hold” or “Retard” functions and verify the following:

- Both evaporator fans operate while the retarder is cooling.
- The liquid line solenoid valve is activated when the retarder is cooling.
- Both the evaporator fans and the liquid line solenoid turn off when the retard temperature is set above the actual temperature.

Turn on the “Proof” or “Rest” functions and verify the following:

- The climitizer fan turns on and stays on after the first call for heat.
- The evaporator fan turns off when the climitizer fan turns on.

Have refrigeration technician hook up refrigeration system.

Step 10:

Set the control clock to the correct day and time. Refer to the retarder control operating manual for set-up and operation instructions. Be sure to arrange for training the operator on programming and use.

Refrigeration Information

Evaporator Kit	BTUs	Fittings	Expansion Valve	Optional Condenser	BTUs	Connections	Charge in pounds
72610-36	2500	3/8"	91500-09	91500-12	3000	3/8-1/4	3.1
72610-37	3500	3/8"	91500-09	91500-13	3900	3/8-1/4	3.3
72610-38	4500	3/8"	91500-23	91500-14	5200	3/8-1/4	3.7
72610-39	5500	1/2 Flare	91500-	91500-15	7400	5/8-3/8	4.3
72610-40	7000	3/8"	(2)91500-09	91500-18	8300	5/8-3/8	7.2
72610-41	9000	3/8"	(2)91500-23	91500-01	10,400	7/8-3/8	7.9
72610-42	11000	3/8"	(2)91500-	91500-21	12,300	7/8-3/8	12.8
72610-43	15000	3/8"	91500-20	91500-24	17,300	7/8-3/8	14.3
72610-44	18000	3/8"	91500-20	91500-34	19,200	7/8-3/8	14.3

Refrigeration Settings:

- Evaporator Superheat = 10 Degrees F
- Compressor Superheat = 25 to 35 Degrees F

In order to achieve the recommended compressor superheat, it is advisable to not insulate the suction line if the condenser is located within 4' of the evaporator. You may also need to extend the suction line with a loop over the condenser so that the suction line is warmed by discharge air from the condenser fan.

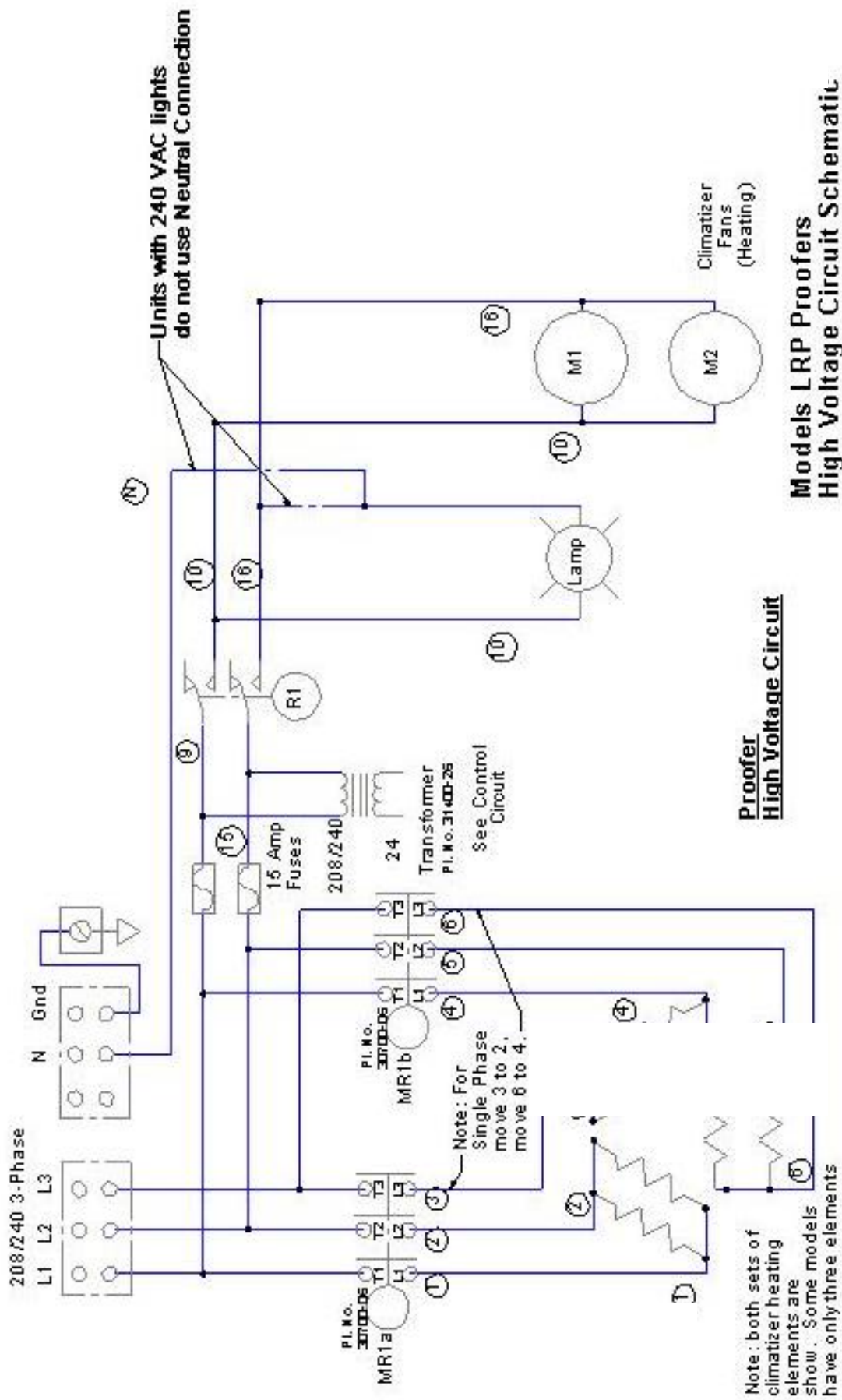

Proofer High Voltage Circuit

Models LRP Prooformers High Voltage Circuit Schematic

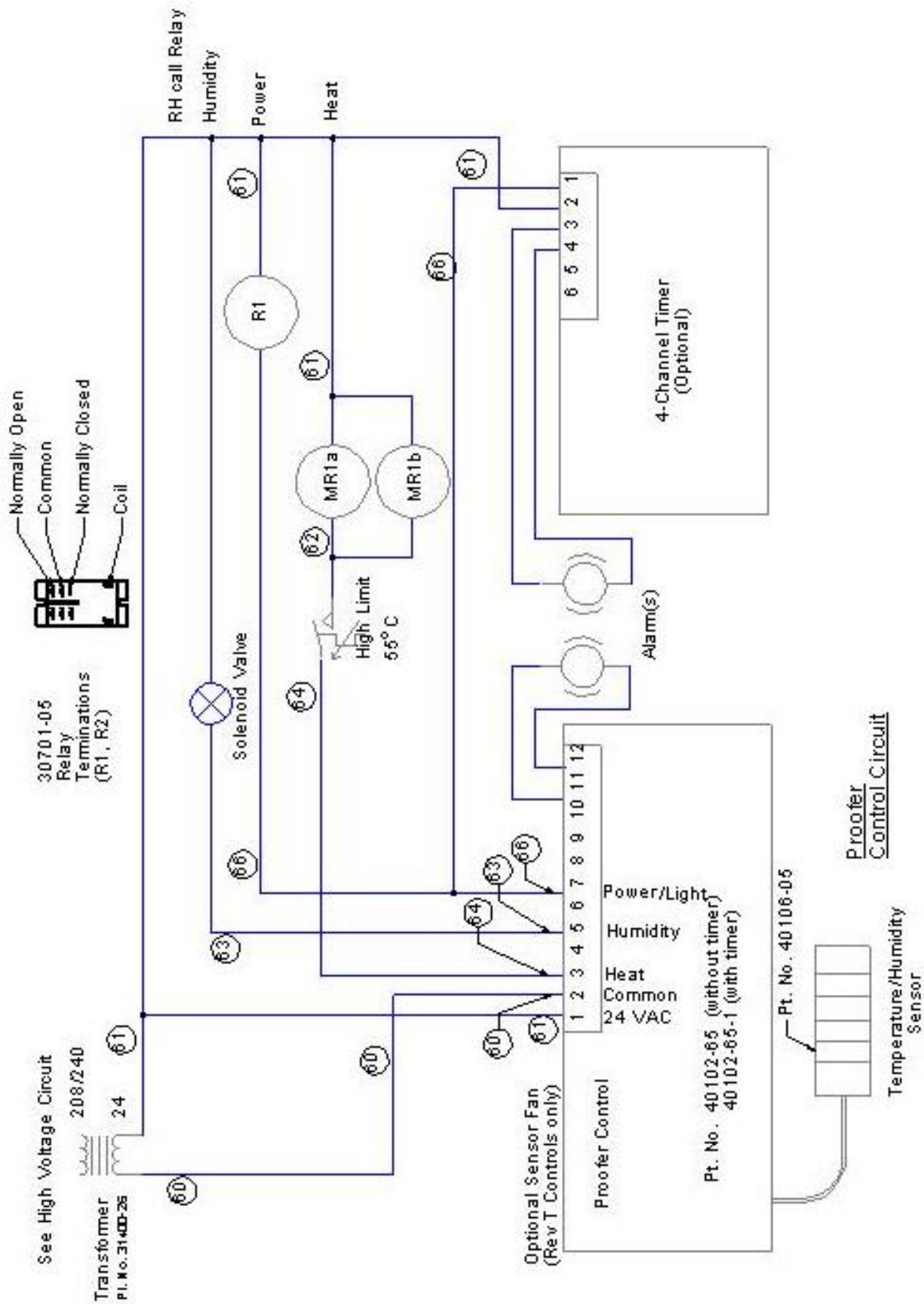

Model LRPR Retarder Proofer

High Voltage Circuit Rev 001 06/2010

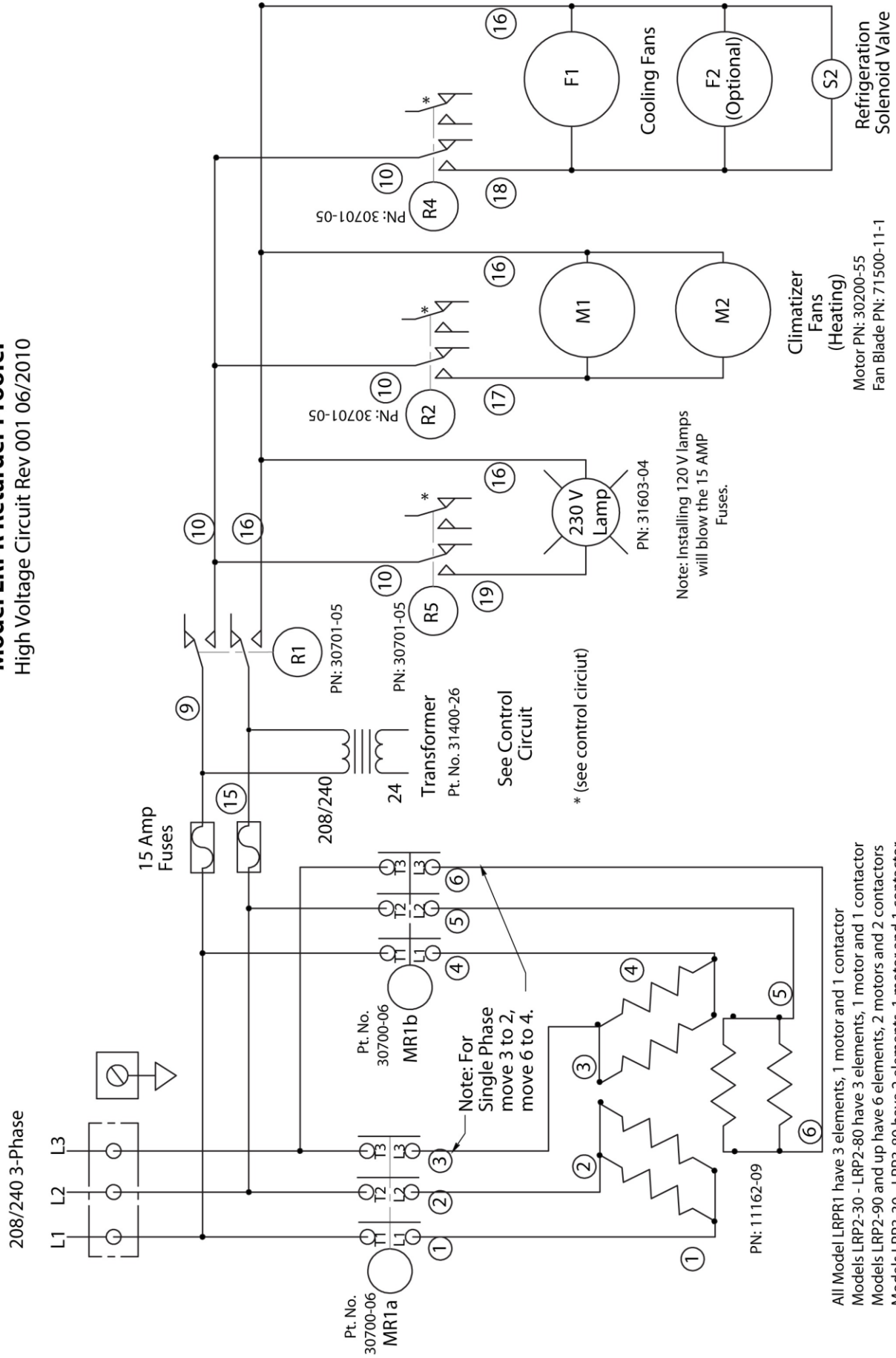

All Model LRPR1 have 3 elements, 1 motor and 1 contactor
 Models LRP2-30 - LRP2-80 have 3 elements, 1 motor and 1 contactor
 Models LRP2-90 and up have 6 elements, 2 motors and 2 contactors
 Models LRP3-30 - LRP3-80 have 2 elements, 1 motor and 1 contactor
 Models LRP3-90 and up have 6 elements, 2 motors and 2 contactors

Large pass trough models may have up to 4 climatizer units.

IMPORTANT: Units with two sets of elements can not be wired for single phase.

See High Voltage Circuit

Transformer
P.L. No. 31400-26

208/240

24

30701-06
Relay
Terminations
(R1 through R5)

- Normally Open
- Common
- Normally Closed
- Coil

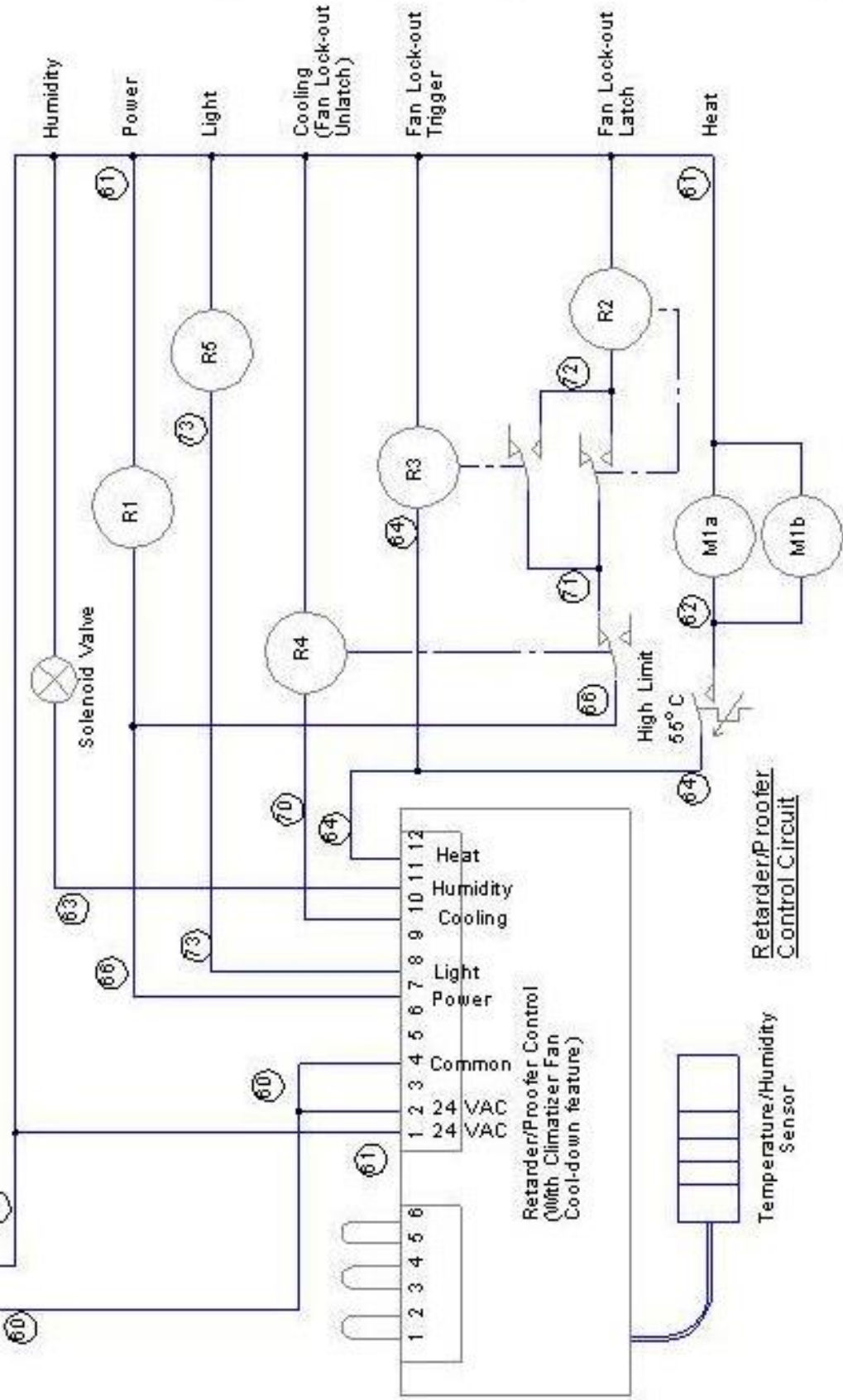

Retarder/Proofer
Control Circuit

Temperature/Humidity
Sensor

PARTS LIST



Control board, Retarder/Proofer (part # **40102-63 REV T**)



Control board, Proofer, with 4-Channel Timer
(part # **40102-65-1**)

[4-channel timer only: part # **40101-21-1**]



Combination Temperature / Humidity Sensor (part # **40106-05**)
Must be installed with fan kit PN: 155-762-1

PARTS LIST CONT.

Item	Qty.	Part No.	Description
*	3	30701-05	Relay, 24-Volt Coil Not shown
1	1	30500-07	Terminal Block, 3-Pole
2	1	30700-06	Contactor, 3-Pole 2 on S-serial #'s
3	1	30701-27	Over temperature thermostat
4	2	30900-01	Fuse, 15 Amp
5	1	70403-01	Solenoid Valve
6	1	70402-07	Manual Valve
7	1	70801-09	Snap Bushing, 1"
8	2	30901-02	Fuse Holder
9	1	31400-26	Transformer 208-240/24-12
10	1	30500-03	Terminal Strip, 6-Pole Not on S- serial #'s

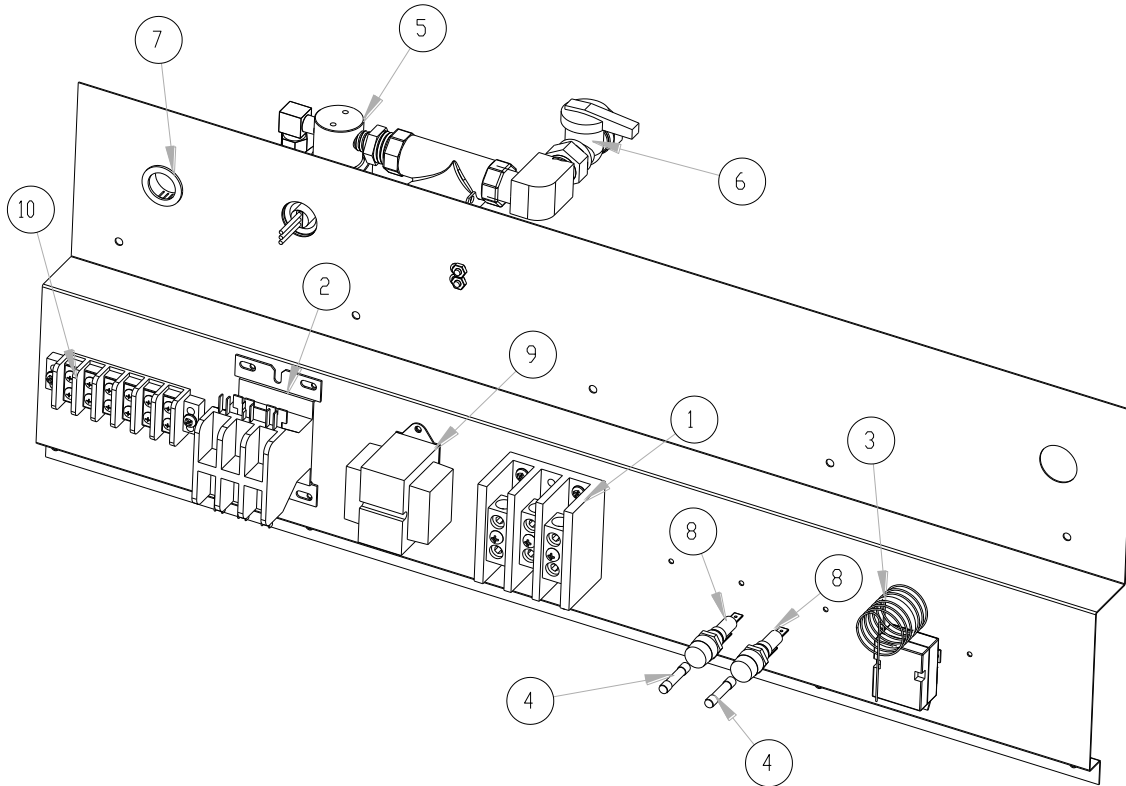

PARTS LIST CONT.

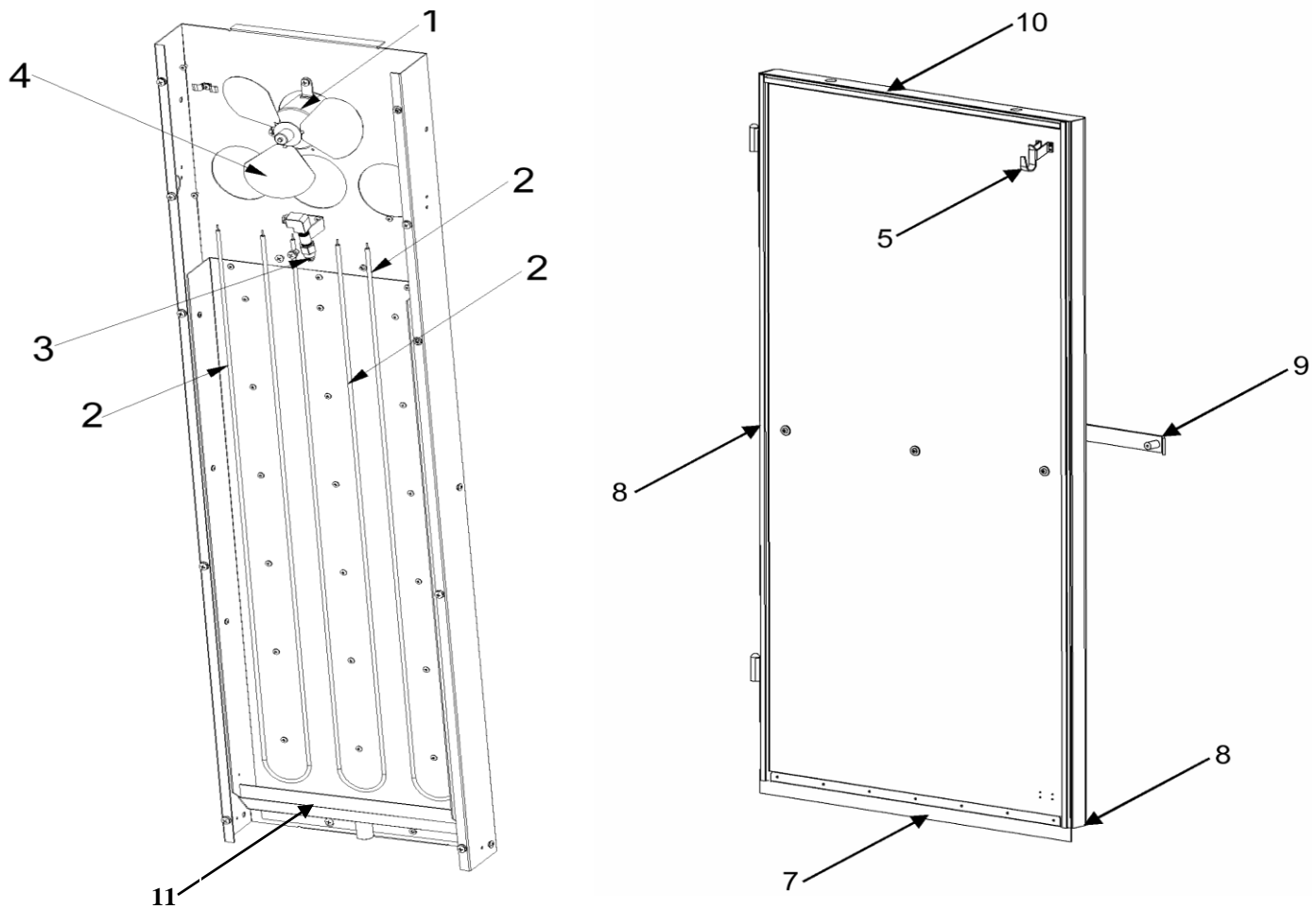

Item No.	Part No.	Description
1	30200-55	Motor, 208/240-Volt
2	11162-09	Element, 240-Volt
3	72610-01	Nozzle Assembly
3	70101-75	Nozzle Orifice
4	71500-11	Blower Fan Assembly
5	70602-24	Door Latch Assembly (2 piece, Door and Body)
7	155-114-1	Door, Bottom Sweeper, 44.68" LRP3 only
7a	155-114	Door, Bottom Sweeper, 33.68" LRP1 & LRP2 only
8	155-131	Door Gasket Grey Silicone, 75.38" LRP2 & LRP3.
8a	72602-211	Door Magnetic Gasket, 75.38" A- Serial # only
8b	72602-211-1	Door Magnetic Gasket, 75.38" S- Serial # only
9	155-702	Door Handle 3 hole LRP1 & LRP2 only
10	72602-21	Door Magnetic Gasket, 33.68" LRP1& LRP2 A- Serial # only
10a	72602-21-1	Door Magnetic Gasket, 33.68" LRP1& LRP2 S- Serial # only
10b	72602-213	Door Magnetic Gasket, 44.68" LRP3 A- Serial # only
10c	72602-213-1	Door Magnetic Gasket, 44.68" LRP3 S- Serial # only
11	155-723	Drip Tray Assembly

PARTS LIST CONT'D

Item No.	Qty.	Part No.	Description
1	1	41100-35	LRP Temperature Sensor Not used on S- serial #'s
2	1	40106-03	Hygrometer Not used on S- serial #'s
2	1	40106-05	Temp/Hygrometer sensor S- serial #'s only
3	1	155-339	Sensor Seal Plate Not used on S- serial #'s
4	1	155-318	Hygrometer Safety Cover Not used on S- serial #'s
5	1	31603-04-1	250V 50W CFL Light Bulb Do Not Use 120V Household bulb
6	1	70602-24	Door Latch
7	1	31602-06	Lamp Socket
7A	1	31602-06-1	Globe
Not Shown	1	31600-14	BALLAST PROOFER 120-277V LRP3 models
Not Shown	1	31600-15	BULB FLOUR 3'COOL WHT 25W 120V LRP3 models

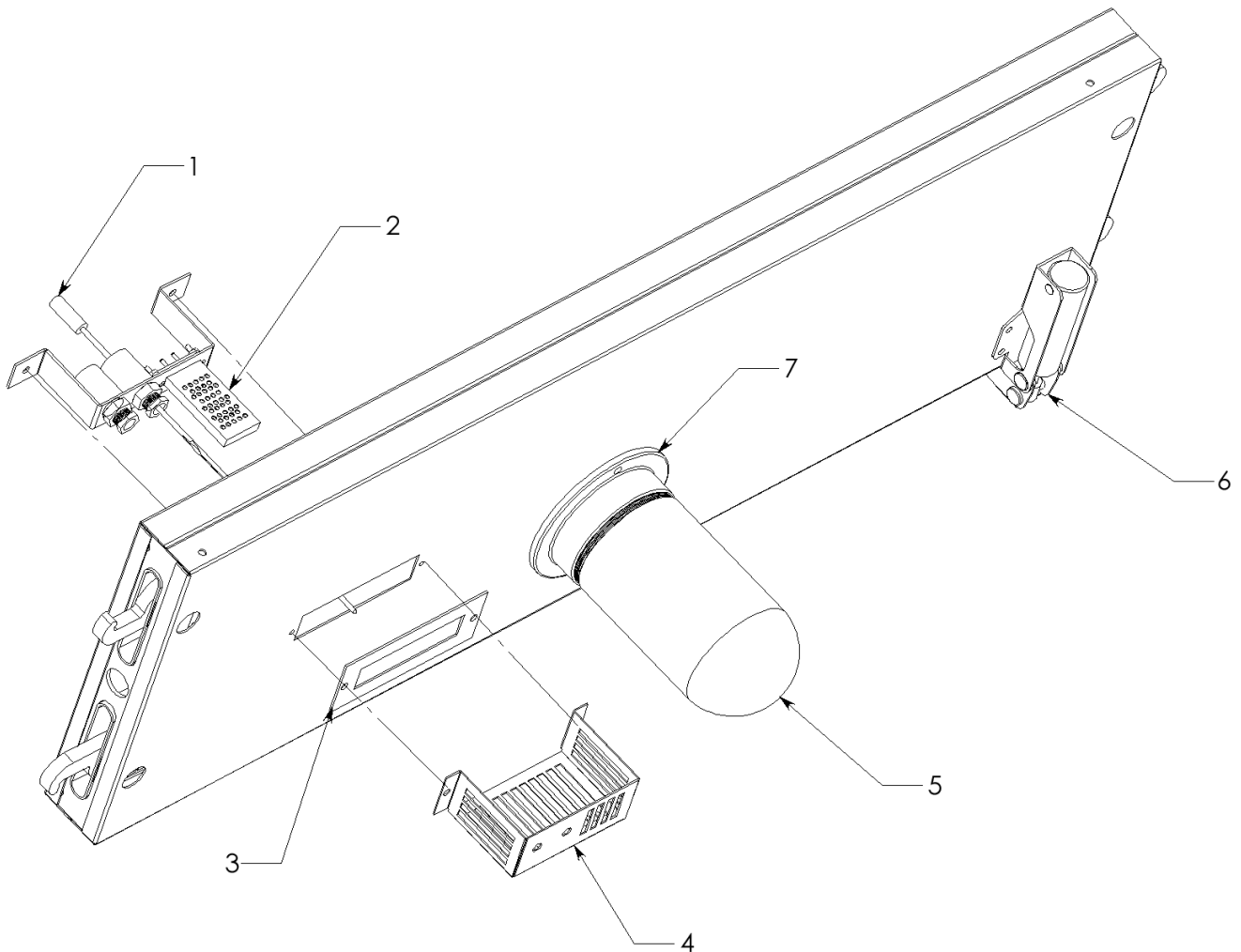



LIMITED WARRANTY

LBC Bakery Equipment ("LBC Equipment") has been skillfully manufactured, carefully inspected and packaged to meet rigid standards of excellence. LBC Bakery Equipment, Inc. (LBC) warrants products produced and sold by LBC and its duly authorized agents against defects in materials and workmanship within the following limitations:

What is Provided:

- Limited replacement parts as specified below, including standard ground shipping from LBC or service parts center when required.
- Limited labor for repair as specified below, including authorized service agent's transportation, portal to portal, up to one hundred (100) miles round trip and two (2) hours travel time.
- LBC, or an authorized service representative, will repair or replace, at LBC's sole discretion, any LBC equipment, including but not limited to the listed exclusions.

Coverage Period:

Extending from the date of shipment from LBC or its duly authorized dealer/distributor for the specified period:

- LRO and LMO Model Rack Ovens, LRP Model Rack Proofers, LRPR Model Retarder Proofers, LCR Model Rotisseries and LHC Model Holding Cabinets for a period of one (1) year limited parts and labor.
- Replacement parts shall be warranted for a period of ninety (90) days after installation by an authorized LBC service agent.

Conditions:

- Covered equipment must have been properly installed according to the requirements of the installation manual and all applicable local codes.
- The equipment shall not have been abused, misused or neglected or used for purposes other than intended by LBC.
- Water connected to the appliance shall have been in compliance with the following requirements:
 - Cold Water: 30 - 80 PSI
 - pH: 7 - 7.5
 - Conductivity: < 1/500,000 Ω per inch
 - Total Dissolved Solids: < 100 ppm
 - Hardness: 6.3 - 8.8 grains per gallon
 - Maximum Salinity and Ion content:
 - Chlorides: < 30 ppm
 - Sulfates: < 40 ppm
 - Iron: < 0.1 ppm
 - Copper: < 0.05 ppm
 - Manganese: < 0.05 ppm
- It is the responsibility of the purchaser to install and maintain the water supply to the appliance. Failure to provide satisfactory water quality in accordance with the operating manual requirements can cause damage to internal components and will VOID the warranty.
- All repair work is to be performed by an LBC authorized service agent.
- Equipment must be at the installation location of the original purchaser/user and shall not have been resold or reclaimed by another party.

Conditions (Continued):

- LBC equipment is for commercial use only. If sold as a component of another (OEM) manufacturer's equipment, or if used as a consumer product, such equipment is sold AS IS and without any warranty.
- Conditions of sale of the equipment shall have been met in full.
- The request for repair shall be made within the limited period of the warranty.
Failure to meet the above conditions will void this warranty.

Exclusions:

This warranty does not cover the following:

- Routine general maintenance, or periodic adjustment.
- Thermostat calibration after the first 30 days of use.
- Glass, Lamps, Gaskets, Oven Racks and other consumable parts.
- Air and gas burner adjustments.
- Fuse replacement.
- Cleaning and adjusting burners and pilot burners.
- Rack oven shutter adjustments.
- Repairs adjustments and corrections in the refrigeration portion of retarder/proofer resulting from the improper installation.
- Retightening of screws and fasteners.
- Failures caused by erratic or inadequate electrical, water, ventilation or gas service.
- Unauthorized repairs.
- Premature rusting, corrosion, or mineral build up caused by incoming water.
- Attached water treatment systems.
- Expedited freight on replacement parts other than standard ground shipments.
- Ordinary wear and tear.
- Use of the equipment for purposes other than those intended including non-commercial use such as residential or domestic.
- Appliances installed outside the contiguous U.S., including Alaska and Hawaii, and Canada.
- Incidental costs, charges, loss of business and damages as incurred by the user or others as a result of the use or failure of the equipment.
- Work and workmanship of the authorized service agent or others in the repair of the equipment.
- Other failures that are beyond the reasonable scope of this warranty.
- Damage caused during shipment is to be reported to the carrier, is not covered under this warranty, and is the sole responsibility of the purchaser/user.
- Natural disaster.

This warranty is exclusive and in lieu of all other warranties, expressed or implied, including expressed or implied warranties of merchantability or fitness for a particular purpose, each of which is hereby expressly disclaimed. The remedies described herein are exclusive and in no event shall LBC be liable for special, consequential or incidental damages for the breach or delay in the performance of this warranty