

**LANCER**

Please refer to the Lancer web site ([www.lancercorp.com](http://www.lancercorp.com)) for information relating to Lancer Installation and Service Manuals, Instruction Sheets, Technical Bulletins, Service Bulletins, etc.

# INSTALLATION AND SERVICE MANUAL

## FOR

### TURBO-CARB HIGH CAPACITY CARBONATOR

Part Number 85-1923-05, 115 Volts, 50/60 Hz,  
with Self Test Board

Part Number 85-1923-06, 115 Volts, 50/60 Hz,  
with Self Test Board and Vented Check Valve

Part Number 85-1926-06, 115 Volts, 50/60 Hz  
with Insulated Tank and Vented Check Valve

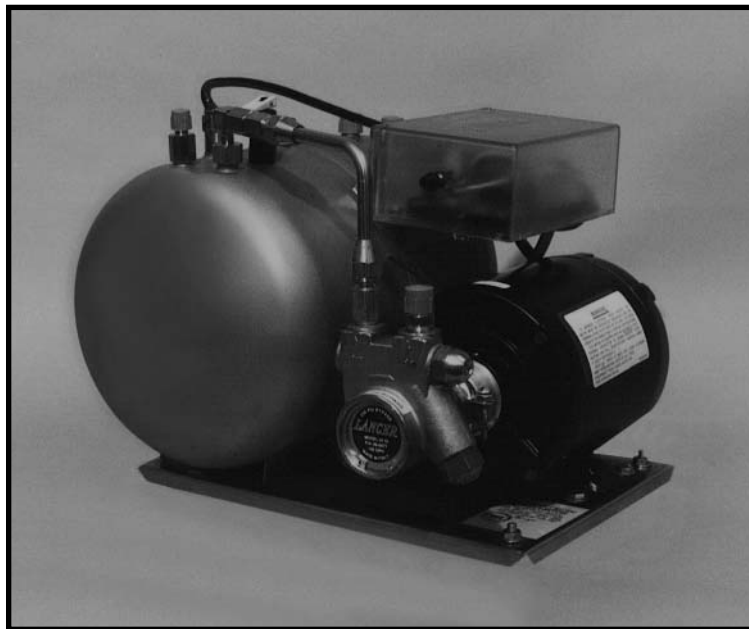

Manufactured for *The Coca-Cola Company*®

***This Manual supersedes Installation and Service Manual 28-0315/05, dated 08/24/00, and is being published only on the Lancer Web Site.***

**LANCER**

6655 LANCER BLVD. • SAN ANTONIO, TEXAS 78219 USA • (210) 310-7000

**FAX SALES**

• NORTH AMERICA – 210-310-7245 • INTERNATIONAL SALES – 210-310-7242 • CUSTOMER SERVICE – 210-310-7242 •  
• LATIN AMERICA – 210-524-9567 / 210-310-7245 • EUROPE – 32-2-755-2399 • PACIFIC – 61-8-8268-1978 •

FAX ENGINEERING: • 210-310-7096

"Lancer" is the registered trademark of Lancer • Copyright — 2001 by Lancer, all rights reserved.

DATE: 10/19/01  
P.N.: 28-0315/06

## TABLE OF CONTENTS

<b>TABLE OF CONTENTS</b> .....	<b>i</b>
<b>SPECIFICATIONS</b> .....	<b>ii</b>
<b>1. INSTALLATION</b> .....	<b>1</b>
1.1 RECEIVING .....	1
1.2 SELECTING LOCATION .....	1
1.3 CONNECT WATER LINE TO PUMP .....	1
1.4 CONNECT CO <sub>2</sub> LINE TO TANK .....	1
1.5 CONNECT CARBONATED WATER TO DISPENSING SYSTEM .....	1
1.6 ELECTRIC POWER SUPPLY .....	1
<b>2. START UP</b> .....	<b>2</b>
2.1 START UP PROCEDURE .....	2
<b>3. CLEANING AND REPLACEMENT</b> .....	<b>2</b>
3.1 CO <sub>2</sub> CHECK VALVE .....	2
3.2 INLET WATER CHECK VALVE .....	2
3.3 PUMP STRAINER SCREEN .....	3
3.4 REPLACING PROBE .....	3
3.5 REPLACING P.C. BOARD .....	3
<b>4. TROUBLESHOOTING</b> .....	<b>4</b>
4.1 MOTOR FAILS TO START (MOTOR HUMS) .....	4
4.2 MOTOR FAILS TO START (MOTOR DOES NOT HUM) .....	4
4.3 MOTOR RUNS CONTINUOUSLY .....	4
4.4 WATER IS RELEASED FROM PRESSURE RELIEF VALVE .....	4
4.5 LOW CARBONATION .....	4
4.6 FOAMY PRODUCT .....	4
<b>5. BASIC GO/NO GO CARBONATOR CONTROL TEST (PN 85-1923-05 and 85-1923-06 ONLY)</b> .....	<b>5</b>
<b>6. ILLUSTRATIONS, PARTS LISTINGS, AND WIRING DIAGRAMS</b> .....	<b>7</b>
6.1 LARGE CARBONATOR TANK .....	7-8
6.2 CO <sub>2</sub> CHECK VALVE ASSEMBLY .....	8
6.3 CHECK VALVE ASSEMBLY .....	8
6.4 PUMP ASSEMBLY .....	9
6.5 WIRING DIAGRAM (PN 06-0266/02) .....	9

## **SPECIFICATIONS**

### **DIMENSIONS**

Width	12 1/4 inches (311 mm)
Depth	15 1/4 inches (387 mm)
Height	11 1/2 inches (292 mm)

### **WEIGHT**

Shipping	33.5 pounds (15.2 kg)
Empty	31.1 pounds (14.1 kg)
Operating	45.3 pounds (20.5 kg)

### **ELECTRICAL**

<b>Domestic</b>	Operating Voltage	115
	Hertz	60
	Amps	6.2
<b>Export</b>	Operating Voltage	230
	Hertz	50/60
	Amps	3.5/3.0

### **MOTOR**

1/3 Horsepower (HP)

### **PUMP**

125 Gallons Per Hour (GPH)  
[473 Liters Per Hour (LPH)]

### **WATER INLET**

3/8 inch S.A.E. Male Flare

### **CO<sub>2</sub> INLET**

1/4 inch S.A.E. Male Flare

### **CARBONATED WATER OUTLET (TWO)**

3/8 inch S.A.E. Male Flare

### **TANK OPERATING CAPACITY**

215 Ounces (6.4 L)

### **THEORY OF OPERATION**

A carbonator is a device designed to dissolve carbon dioxide gas (CO<sub>2</sub>) in water, producing carbonated water. CO<sub>2</sub> gas is delivered through a regulator to the carbonator tank. Simultaneously, plain water is pumped into the tank. The CO<sub>2</sub> gas, under pressure, dissolves in the water and the result is carbonated water. When the level of carbonated water reaches a pre-determined point, the liquid level sensing device (inside the tank) signals the liquid level control module which, in turn, shuts off the pump motor. As carbonated water is drawn from the tank, the level of carbonated water will drop. At a certain point, the liquid level sensing device recognizes that drop in the level and turns on the pump motor which replenishes the amount of carbonated water that has been taken out of the tank.



## 1. INSTALLATION

### 1.1 RECEIVING

- A. Each unit is completely tested under operating conditions and thoroughly inspected before shipment. At the time of shipment, the carrier accepts the unit and any claim for damage(s) must be made with the carrier. Upon receiving units from the delivering carrier, carefully inspect carton for visible indication(s) of damage. If damage exists, have carrier note same on bill of lading and file a claim with the carrier.
- B. Open the top of the carton. Remove interior packing. Carefully lift the Carbonator out of carton.
- C. Inspect for concealed damage(s) and if detected, notify delivering carrier and file claim.

### 1.2 SELECTING LOCATION

- A. Select a level, well ventilated, accessible location convenient to water and electric supply. The selected location should be able to withstand a load of 100 pounds (45.5 kg).

### 1.3 CONNECT WATER LINE TO PUMP

- A. Connect Flexible Pressure Tubing, 3/8 inch ID or larger, from water supply to Pump Inlet using a 3/8 inch SAE Female Swivel Nut (PN 01-0232) and Flare Seal Washer (PN 05-0017).
- B. A Shutoff Valve should be installed in water line to Carbonator.
- C. Water supply must provide a minimum flow rate of 125 GPH (473 LPH), and have a minimum pressure of 25 PSIG (1.83 kg/cm<sup>2</sup>) and a maximum of 80 PSIG (5.62 kg/cm<sup>2</sup>). If water pressure exceeds 80 PSIG (5.62 kg/cm<sup>2</sup>), install a Regulator (Lancer models are available) and adjust to 50 PSIG (3.51 kg/cm<sup>2</sup>).
- D. Off tastes and excessive silt, sand, or iron require that a water filter be installed in the water line supplying the Carbonator. The water filter should be checked periodically, as required by local conditions.

#### **NOTE**

Do not connect to a heated (hot) water source or a water source supplying soft water. This will cause excessive foaming.

### 1.4 CONNECT CO<sub>2</sub> LINE TO TANK

- A. Connect Flexible Pressure Tubing, 1/4 inch ID or larger from CO<sub>2</sub> Regulator to the Tank Inlet using a 1/4 inch SAE Female Swivel Nut and Flare Seal Washer.
- B. CO<sub>2</sub> supply must have a Regulator (Lancer models are available) and Gauge (Lancer models are available) adjustable from 0 to 150 PSIG (3.5 kg/cm<sup>2</sup>) minimum.

### 1.5 CONNECT CARBONATED WATER TO DISPENSING SYSTEM

- A. Connect Flexible Pressure Tubing, 3/8 inch ID or larger, from Dispensing System to Outlet on Tank, using a 3/8 inch SAE Female Swivel Nut and Flare Seal Washer.
- B. If only one Carbonated Water Outlet on the Tank is used, the other Outlet must be capped with a Stainless Steel Cap Nut (PN 01-0212) and Flare Seal Washer (PN 05-0017).

### 1.6 ELECTRIC POWER SUPPLY

#### **WARNING**

**THIS UNIT MUST BE PROPERLY ELECTRICALLY GROUNDED TO AVOID POSSIBLE FATAL ELECTRICAL SHOCK OR SERIOUS INJURY TO THE OPERATOR. THE POWER CORD IS PROVIDED WITH A THREE PRONG GROUNDED PLUG. IF A THREE HOLE GROUNDED ELECTRICAL OUTLET IS NOT AVAILABLE, USE AN APPROVED METHOD TO GROUND THE UNIT.**

- A. The electric power supply must be a three prong, ground convenience outlet having the same configuration as the power cord.
- B. Outlet must have proper voltage, cycles and ampere ratings. See Carbonator Name Plate for ratings.

#### **NOTE**

*Do not plug into electrical outlet unless ratings on name plate agree with local current available.*

## 2. START UP

### 2.1 START UP PROCEDURE

- A. Turn water supply ON, and start filling Tank.
- B. Pull UP on Pressure Relief Valve Yellow Lever to allow air to escape.
- C. Hold Pressure Relief Valve OPEN, until Tank is full and water spurts out of Valve.
- D. Check for water leaks.
- E. Turn on CO<sub>2</sub> supply and set Regulator at 100 PSIG (7.03 kg/cm<sup>2</sup>).
- F. Check for CO<sub>2</sub> leaks (see Section 3.1).

#### **WARNING**

**THIS UNIT MUST BE PROPERLY ELECTRICALLY GROUNDED TO AVOID POSSIBLE FATAL ELECTRICAL SHOCK OR SERIOUS INJURY TO THE OPERATOR. THE POWER CORD IS PROVIDED WITH A THREE PRONG GROUNDED PLUG. IF A THREE HOLE GROUNDED ELECTRICAL OUTLET IS NOT AVAILABLE, USE AN APPROVED METHOD TO GROUND THE UNIT.**

- G. Plug in power supply.
- H. Open a Dispensing Valve. Allow water to flow until Pump Motor turns on.
- I. Close Dispensing Valve and allow Pump Motor to cycle off.
- J. Repeat steps H and I several times, until carbonated water flows freely from Valve.
- K. Check for leaks (see Section 3.2).
- L. Check CO<sub>2</sub> Regulator to ensure that CO<sub>2</sub> pressure has not changed.

## 3. CLEANING AND REPLACEMENT

### 3.1 CO<sub>2</sub> CHECK VALVE

- A. UNPLUG Power Cord.
- B. Shut water supply OFF to Pump.
- C. Turn CO<sub>2</sub> supply OFF and set CO<sub>2</sub> pressure regulator at 0 PSIG.
- D. Disconnect CO<sub>2</sub> supply line from CO<sub>2</sub> Check Valve.

#### **CAUTION**

DO NOT PROBE VALVE WITH ANY OBJECT.

- E. Cover end of Check Valve with soap suds. If Check Valve is defective, gas bubbles will appear. If a leak is detected, continue with the following steps.
- F. Release pressure in Tank, using Relief Valve.
- G. Disassemble Check Valve Body and components. Inspect Spring and O-Rings. Replace as required.
- H. Reassemble and reinstall Check Valve.
- I. Reconnect CO<sub>2</sub> supply line to CO<sub>2</sub> Check Valve.
- J. Follow start up procedure (see Section 2.1) to put Carbonator back into operation.

### 3.2 INLET WATER CHECK VALVE

#### **CAUTION**

A LEAKING INLET WATER CHECK VALVE WILL ALLOW CARBONATED WATER TO FLOW BACK THROUGH THE PUMP (WHEN IT IS SHUT OFF), AND CONTAMINATE THE WATER SUPPLY.

- A. UNPLUG Power Cord.
- B. Shut water supply OFF to Pump.
- C. Set CO<sub>2</sub> pressure at 100 to 125 PSIG (7.0 to 8.8 kg/cm<sup>2</sup>).
- D. Disconnect Stainless Steel Water Line from Water Inlet Check Valve. *Do not loosen Check Valve Assembly.*

#### **CAUTION**

DO NOT PROBE VALVE WITH ANY OBJECT.

- E. Cover end of Check Valve with soap suds. If Check Valve is defective, gas bubbles will appear. If a leak is detected, continue with the following steps. If no leak is detected, proceed to Step J below.

- F. Turn CO<sub>2</sub> pressure OFF. Release pressure in Tank, using Relief Valve.
- G. Disassemble Check Valve Body and components. Inspect Spring and O-Rings. Replace as required.
- H. Reassemble and reinstall Check Valve.
- I. Reconnect Stainless Steel Line to water inlet Check Valve.
- J. Follow start up procedure (see Section 2.1) to put Carbonator back into operation.

### 3.3 PUMP STRAINER SCREEN

- A. UNPLUG Power Cord.
- B. Shut water supply OFF to Pump.
- C. Unscrew Brass Plug on Pump, and remove Strainer from Pump.
- D. Inspect and clean, or replace, Strainer Screen.
- E. Reinstall Strainer, and tighten Brass Plug.
- F. Turn water supply ON.
- G. Check for leaks. If a leak is detected, carefully tighten Brass Plug.

#### **WARNING**

**THIS UNIT MUST BE PROPERLY ELECTRICALLY GROUNDED TO AVOID POSSIBLE FATAL ELECTRICAL SHOCK OR SERIOUS INJURY TO THE OPERATOR. THE POWER CORD IS PROVIDED WITH A THREE PRONG GROUNDED PLUG. IF A THREE HOLE GROUNDED ELECTRICAL OUTLET IS NOT AVAILABLE, USE AN APPROVED METHOD TO GROUND THE UNIT.**

- H. Plug Power Cord into electrical outlet.

### 3.4 REPLACING PROBE

- A. UNPLUG Power Cord.
- B. Shut water and CO<sub>2</sub> gas supplies OFF.
- C. Remove Cover from PC Board enclosure by removing screws.
- D. Unplug Probe Leads from PC Board.
- E. Pull lever on Pressure Relief Valve to relieve CO<sub>2</sub> pressure on Tank.
- F. Unscrew Probe from top of Tank.
- G. Screw new Probe into top of Tank. *Be sure to install White Plastic Washer (PN 02-0096) as a water tight seal seal will not be obtained without the washer.*
- H. Connect Probe Leads to PC Board as follows:

Green	G
Black	LO
White	HI

- I. Slide Probe Strain Relief into slot, replace cover and secure cover with screws.
- J. Follow start-up procedure (see Section 2.1) for putting Carbonator back into operation.

### 3.5 REPLACING PC BOARD

- A. UNPLUG Power Cord.
- B. Carefully remove Cover from PC Board enclosure by removing two (2) screws, and disconnect Switch Assembly from PC Board.
- C. Unplug Probe Leads, Power Cord Leads, and Motor Cord Leads from PC Board.
- D. Unscrew and remove PC Board Assembly.
- E. Install new PC Board and secure with screws.
- F. Connect push on Leads to PC Board as follows.

1. <u>Probe</u>	2. <u>Power Cord</u>	3. <u>Motor Cord</u>
Green    G	Black    1	Black    3
Black    LO	White    2	White    4
White    HI		

- G. Reconnect Switch Assembly to PC Board and install cover. Secure cover with two (2) screws.

### **WARNING**

**THIS UNIT MUST BE PROPERLY ELECTRICALLY GROUNDED TO AVOID POSSIBLE FATAL ELECTRICAL SHOCK OR SERIOUS INJURY TO THE OPERATOR. THE POWER CORD IS PROVIDED WITH A THREE PRONG GROUNDED PLUG. IF A THREE HOLE GROUNDED ELECTRICAL OUTLET IS NOT AVAILABLE, USE AN APPROVED METHOD TO GROUND THE UNIT.**

H. Plug Power Cord IN.

#### **4. TROUBLESHOOTING**

<b><u>TROUBLE</u></b>	<b><u>CAUSE</u></b>	<b><u>REMEDY</u></b>
4.1 Motor fails to start (Motor hums).	A. Pump binding. B. Open Winding infield.	A. Loosen Pump Clamp and rotate Pump slightly to free binding, If this fails, replace Pump. B. Replace Motor.
4.2 Motor fails to start (Motor does not hum).	A. Cutout due to overloading by Pump binding. B. Blown Fuse, or Circuit Breaker tripped. C. Defective Motor. D. Defective PC Board. E. Defective Probe.	A. Let Motor cool and follow Pump binding remedy. B. Replace Fuse or reset Circuit Breaker. C. Replace Motor. D. Replace PC Board. E. Replace Probe.
4.3 Motor runs continuously.	A. Water supply shut off. B. Water supply pressure less than 25 PSIG (1.86 kg/cm <sup>2</sup> ).  C. Restriction in Water Supply Line. D. Restriction in Inlet Water Check Valve. E. Restriction in Pump.  F. Defective PC Board. G. Defective Probe.	A. Reestablish water supply. B. Connect Pressure Gage to Pump Tee and increase Pump By-Pass pressure to 200 PSIG (14.1 kg/cm <sup>2</sup> ). C. Locate restriction and establish proper flow. D. Disassemble Inlet Water Check Valve and clean. E. Remove and clean Pump Strainer. If Pump is still restricted, replace Pump. F. Replace PC Board. G. Replace Probe.
4.4 Water is released from Pressure Relief Valve.	A. Defective seal in Pressure Relief Valve. B. Defective Spring in Pressure Relief Valve.	A. Replace Pressure Relief Valve. B. Replace Pressure Relief Valve.
4.5 Low Carbonation.	A. Low CO <sub>2</sub> pressure. B. Leaking CO <sub>2</sub> Supply Line.	A. Increase CO <sub>2</sub> pressure or replace CO <sub>2</sub> tank. B. Locate leak and repair.
4.6 Foamy Product.	A. Over carbonation. B. Dirty Product Valve.  C. Product temperature too high.	A. Reduce CO <sub>2</sub> pressure. B. Disassemble and clean Product Valve. C. Product temperature must be below 42°F (5.5°C). Check cooling system.

**5. BASIC GO/NO GO CARBONATOR CONTROL TEST (PN 85-1923-05 and 85-1923-06 ONLY)**

Part Number 06-1236/01, found on the cover of the Carbonator Assembly, provides a basic trouble-shooting procedure to determine if the liquid level control is operating properly. The test which is self-explanatory (see illustration) will help isolate problems to the probe, motor or PC Board.

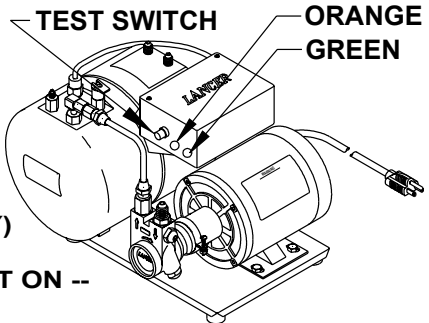
<p><b>NOTE: IN CASE OF CARBONATION PROBLEMS, VERIFY □ CARBONATOR OPERATION BY DRAWING DRINKS. IF □ PROBLEMS PERSIST, FOLLOW THE STEPS LISTED BELOW.</b></p>	
<p><b>STEP 1--OBSERVE GREEN LIGHT OFF-----CHECK POWER SUPPLY ON-----GO TO STEP 2</b></p>	
<p><b>STEP 2--PUSH TEST SWITCH (WITH TANK EMPTY) MOTOR STARTS-----REPLACE PROBE MOTOR DOES NOT START AND ORANGE LIGHT ON -- REPLACE MOTOR ORANGE LIGHT OFF-----REPLACE BOARD</b></p>	
<p><b>STEP 3--IF MOTOR DOES NOT TURN OFF---- REPLACE BOARD AND PROBE</b></p>	<p><b>LANCER</b> 06-1236/01</p>

# **NOTES**

***LANCER***<sup>®</sup>

*Please refer to the Lancer web site ([www.lancercorp.com](http://www.lancercorp.com)) for information relating to Lancer Installation and Service Manuals, Instruction Sheets, Technical Bulletins, Service Bulletins, etc.*

## 6. ILLUSTRATIONS, PARTS LISTINGS, AND WIRING DIAGRAMS

### 6.1 LARGE CARBONATOR TANK

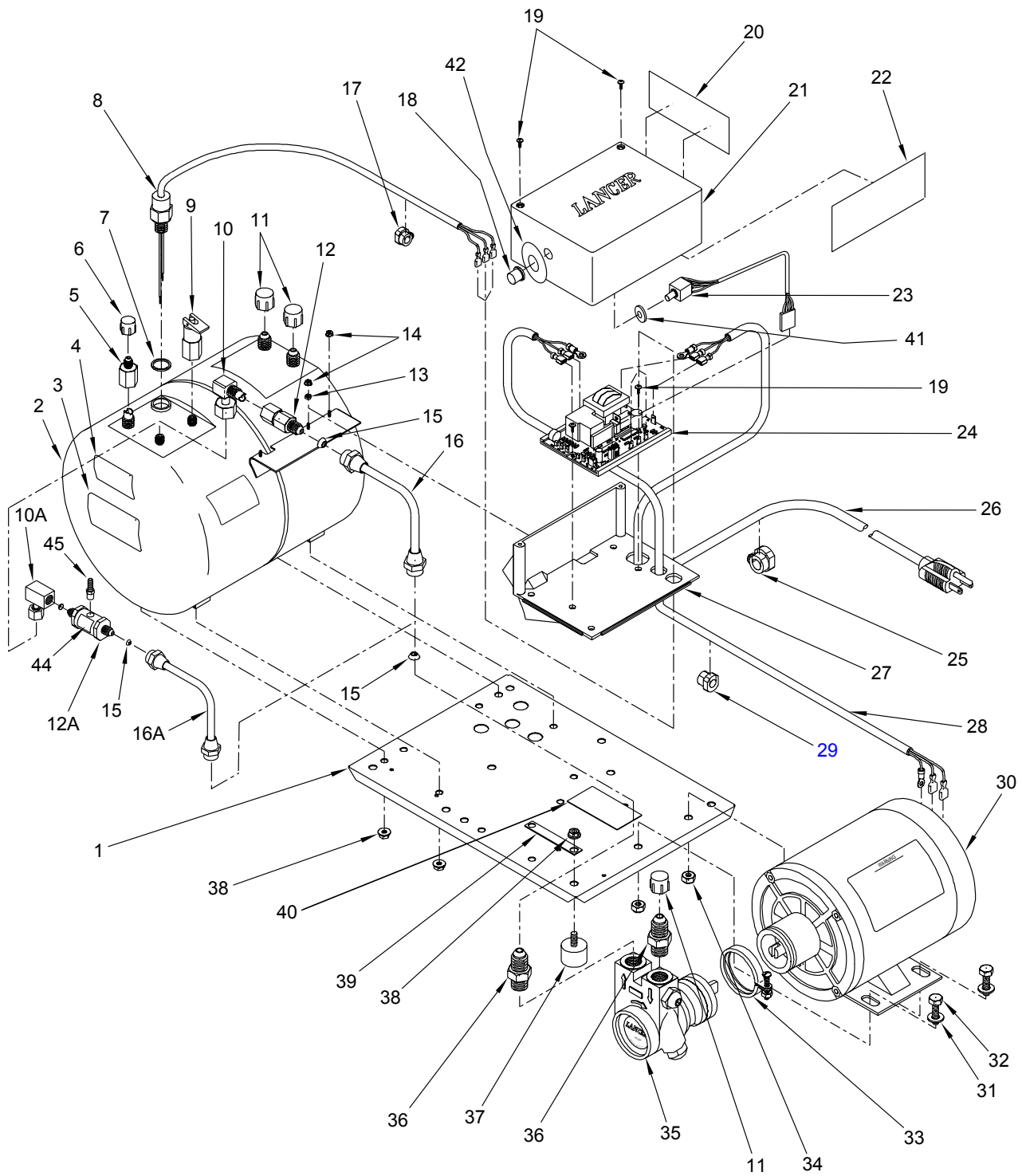

## 6.1 LARGE CARBONATOR TANK (CONTINUED)

ITEM	PART NO.	DESCRIPTION	ITEM	PART NO.	DESCRIPTION
1	07-0199	Base Plate	23	52-1739	Switch Sub Assy
2	23-0369	Tank Assy	R 24	52-1677	PCB, LLC, 115V, Self Test
-	42-0015	Tank Assy, Insulated	R --	52-1017	PCB, LLC, 115V
3	06-0039	Label, Warning	25	13-0028	Strain Relief
4	06-1134	Label, CO2 Pressure	26	52-2159	Power Cord Assy
5	17-0342	CO2 Check Valve Assy	R 27	05-0529-01	Enclosure, Clear
6	04-0044	Protector Cap	R --	05-0529	Enclosure
7	02-0096	Washer	28	52-0585	Motor Cord Assy
8	52-0590/01	Probe	29	13-0008	Strain Relief
9	54-0066	Relief Valve Assy	30	91-0008	Motor, 115 VAC
10	17-0083	Fitting Assy	31	04-0033	Washer
10A	01-2013	Fitting Assy, 3/8" Female Flare	32	04-0520	Hex Bolt, 1/4 - 20 x 1/2 Inch
11	04-0045	Protector Cap	33	07-0017	Clamp
12	17-0341	Check Valve Assy	34	04-0032	Nut, 1/4 - 20 Nylock
12A	17-0556	Check Valve Assy, Vented	35	86-0085	Pump
13	04-0049	Nut	36	01-0111	Adapter
14	04-0297	Keps Nut	37	04-0247	Isolator Foot
15	05-0017	Flare Seal	38	04-0034	Lock Nut
16	48-1449	Tube Assy, Insulated	39	11-0004	Connector
-	48-1469	Tube Assy, Non-Insulated	40	06-0003/02	Name Plate
16B	48-1449	Tube Assy, Non-Insulated	41	04-0836	Lock Washer, Internal Tooth, 1/4 Inch
17	13-0026	Strain Relief	42	06-1289	Label, Test Switch
18	12-0241	Boot, Splashproof	43	06-2014/01	Label, Warning, CO2 Check Valve
19	04-0470	Screw	44	06-2251	Label, Warning, CO2 Check Valve
20	06-0266/02	Label, Wiring Diagram	45	01-1877	Adapter, 1/8 MNPT x 1/8 Barb, SS
R 21	05-0528-01	Cover, Clear			
R --	05-0528	Cover			
22	06-1236/01	Label, Troubleshoot			

**NOTE:** R in margin indicates change or revision

## 6.2 CO2 CHECK VALVE ASSEMBLY

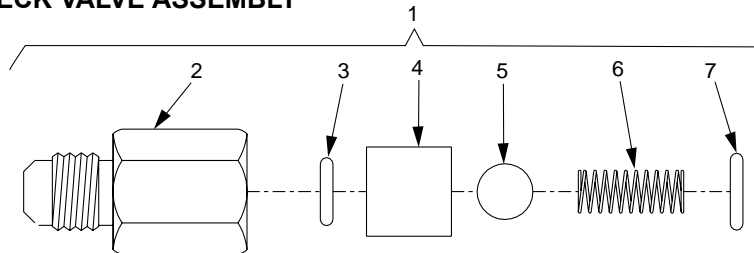

ITEM	PART NO.	DESCRIPTION	ITEM	PART NO.	DESCRIPTION
1	17-0342	CO2 Check Valve Assy	5	01-0674	Ball
2	01-0669	Body	6	03-0021	Spring
3	02-0025	O-Ring	7	02-0003	O-Ring
4	01-0689	Sleeve			

## 6.3 CHECK VALVE ASSEMBLY

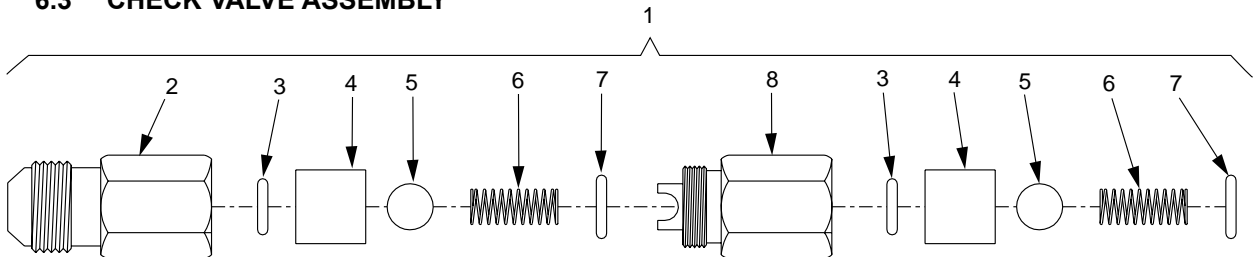

ITEM	PART NO.	DESCRIPTION	ITEM	PART NO.	DESCRIPTION
1	17-0341	Check Valve Assy	5	01-0674	Ball
2	01-0673	Body	6	03-0021	Spring
3	02-0025	O-Ring	7	02-0003	O-Ring
4	01-0689	Sleeve	8	01-0670	Body

## 6.4 PUMP ASSEMBLY

ITEM	PART NO.	DESCRIPTION	ITEM	PART NO.	DESCRIPTION
1	86-0085	Pump Assy	5	17-0438	Bypass Valve Assy
2	10-0175	Housing	-	17-0439	Bypass Valve Assy, Stainless Steel
-	10-0176	Housing, Stainless Steel	-	10-0396	Bypass Valve Assy, Replaceable Bypass
-	10-0395	Housing, Replaceable Bypass	6	81-0103	Bypass Valve Filter
3	54-0152	Bypass Seat Sub Assy	7	03-0132	Spring Relief Valve
4	02-0115	O-Ring	8	02-0192	Gasket, Acorn Nut
			9	01-1771	Acorn Nut, Relief Valve
			-	01-1198/01	Acorn Nut, Relief Valve, Stainless Steel
			10	10-0394	Relief Valve, Adjustment Screw
			-	10-0183	Relief Valve, Adjustment Screw, Stainless Steel
			-	10-0397	Relief Valve, Adjustment Screw, Replaceable Bypass
			11	02-0181	O-Ring, Adjustment Screw
			12	82-0415	Strainer
			13	02-0185	O-Ring, Strainer Nut
			14	01-1196/01	Cap Nut, Strainer

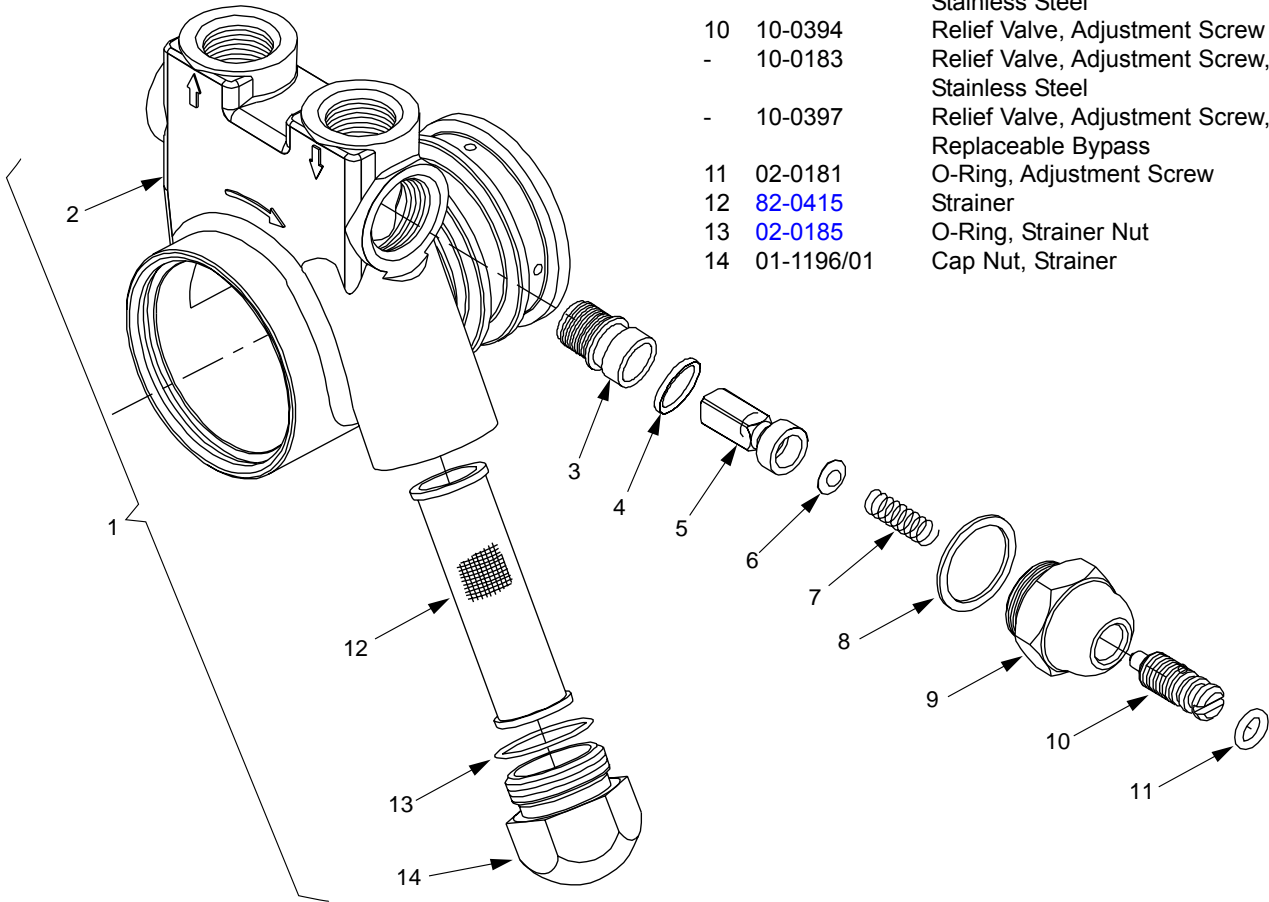

## 6.5 WIRING DIAGRAM (PN 06-0266/02)

