

MAC Series Operation Manual



Manitowoc Foodservice Walk-In Division

2915 Tennessee Avenue North

Parsons, TN 38363

Phone: 800-225-9916

www.manitowocfoodservice.com

P/N 550003765 REV. 5

August, 2014

ECO KPR114586

Table of Contents

Cool Start Guide	4 - 5
Safety Information	6
Condensing Unit Specifications	7
Evaporator Unit Specifications	8
Receiving Inspection	9
Locating and Mounting Condensing Units	9 – 10
Locating and Mounting Evaporator Coils	11
Condensing Unit and Evaporator Coil Wiring.....	12
Piping	12 - 14
Leak Test	15
Evacuation	16
Refrigerant Charging	17
Compressor Mounts.....	17
ArcticFox Interface Installation.....	18 - 19
Operational Start-Up	20
Compressor Superheat	21
Evaporator Superheat	22
ArcticFox Features.....	23
ArcticFox Wiring.....	24
ArcticFox Initialization.....	25
ArcticFox Button Functions.....	25
ArcticFox Programming.....	26 – 30
ArcticFox Alarm Codes.....	31
Sustaining Mode.....	31
Data Logging.....	32
On Demand Defrost.....	32
System Defaults.....	32 – 36
Parts List.....	37 - 38
Maintenance	39
Warranty Information	40
System Start-Up Data Sheet	41
Appendices.....	42 – 51
A – Sensor Failure Codes.....	42 – 43
B – Cooler or Freezer Set Up.....	44
C – Defrost Set Up.....	45
D – Condensing Unit Wiring Diagram.....	46 - 47
E – Air Defrost System Wiring Diagram.....	48
F – Electric Defrost System Wiring Diagram.....	49
G – Standard Exterior Door Section Wiring.....	50
H – Standard Partition Door Section Wiring	51

ArcticFox Cool Start Guide:

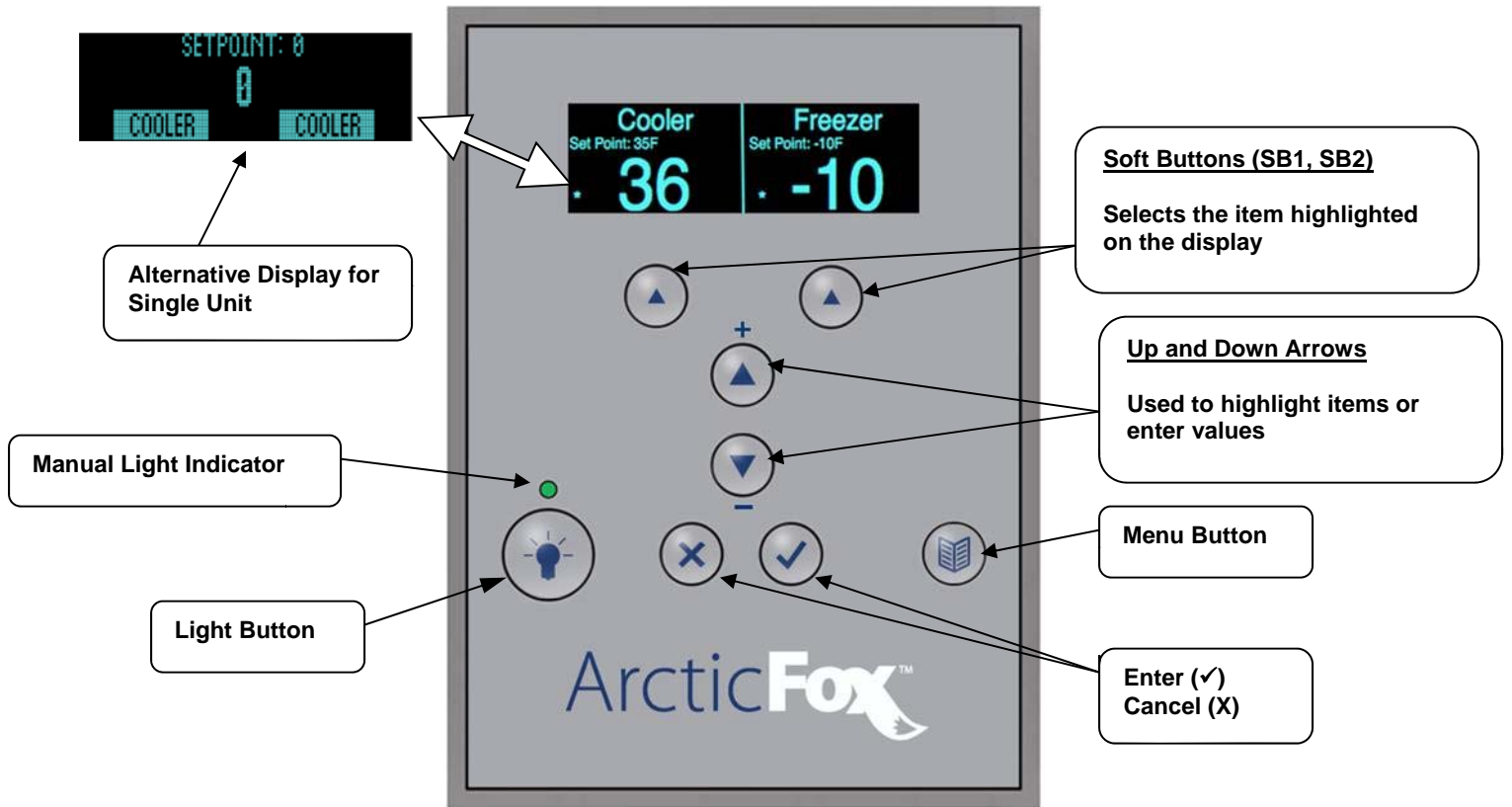

Note: Dual control mode shown

General operation of the UI:

- SB1 and SB2 perform or select the item that is highlighted above it. In the case of the picture above pressing SB1 will activate the “Cooler” menu.
- The Up and Down arrows are used to select items from a list or adjust the value of a setting.
- The <X> key has the following functionality:
 - Cancels entry of current setting
 - Silences the Alarm for 5 minutes
 - Stops the status scrolling on the top of the display (The enter key also stops the scrolling). Pressing either the <X> or the <✓> key will resume scrolling (there may be a 1-2 second delay for the scrolling to start again).
- With the scrolling stopped the Up or Down arrows change the parameter shown.
- The light key turns on both the Cooler and Freezer’s lights (if walk-in is so equipped).
- The <Menu> key allows access (with password) to the system parameters and other service features.
- The <✓> key “enters” or “accepts” a choice while changing settings.

Function	Steps
Set Time and Date	<ol style="list-style-type: none"> 1. Press the <Menu> button and enter password (AAAA is default) 2. Enter password, then press <✓> 3. Press <Down> to scroll to "Set Date & Time", then press <✓> 4. Press <Up> or <Down> to select the hour, then press <✓> 5. Press SB2 (under NEXT) to move on to the minute screen. 6. Follow steps until time & date are set, then press < X > to return to main display
Set Temperatures	<ol style="list-style-type: none"> 1. Press <SB1> or <SB2> and enter password (AAAA is default) 2. Press <Up> or <Down> to change the desired temperature 3. Press <✓> to enter selection 4. Press <X> to return to main display
Set Temperature Alarms	<ol style="list-style-type: none"> 1. Press <SB1> or <SB2> and enter password (AAAA is default) 2. Press <SB2> to navigate to "SET COOLER HIGH ALARM" 3. Press <Up> or <Down> to obtain the desired setting 4. Press <SB2> to navigate to "SET COOLER LOW ALARM" 5. Press <Up> or <Down> to obtain the desired setting 6. Press <✓> to enter selection 7. Press <X> to return to main display
Set Door Alarm Time	<ol style="list-style-type: none"> 1. Press <SB1> or <SB2> and enter password (AAAA is default) 2. Press <SB2> to navigate to "SET COOLER DOOR ALARM TIME" 3. Press <Up> or <Down> to obtain the desired setting 4. Press <✓> to enter selection 5. Press <X> to return to main display
Silence Alarms	<p>Pressing <X> will silence the alarm for 5 minutes</p> <p>Pressing <X> and <✓> simultaneously for 3 seconds will permanently silence alarm</p>
Clearing Alarms	<ol style="list-style-type: none"> 1. Press <SB1> or <SB2> and enter password (AAAA is default) 2. Press <SB1> to navigate to "CLEAR COOLER ALARMS" 3. Press <Up> or <Down> to obtain the desired setting 4. Press <✓> to enter selection 5. Press <X> to return to main display
Set User Password	<ol style="list-style-type: none"> 1. Press the <Menu> button 2. Enter password, then press <✓> 3. Press <Down> to scroll to "Set User Password", then press <✓> 4. Enter old password (default is AAAA) and press <✓> 5. Enter new password and press <✓> 6. Re-enter new password to confirm and press <✓> 7. Press <X> twice to return to main display.
Set Service Password	<ol style="list-style-type: none"> 1. Press the <Menu> button 2. Enter password, then press <✓> 3. Press <Down> to scroll to "Service Menu", then press <✓> 4. Press <Down> to scroll to "Set Service Password", then press <✓> 5. Enter old password (default is ZZZZ) and press <✓> 6. Enter new password and press <✓> 7. Re-enter new password to confirm and press <✓> 8. Press <X> three times to return to main display.

Note: If the walk-in is a freezer, substitute freezer in place of cooler nomenclature.

General Safety Information:

Read this manual carefully before beginning the installation and operation of the refrigeration system. Special attention is required to all sections identified with the following warning and caution notices:

⚠ WARNING

Text in a Warning box alerts you to a potential personal injury situation. Read each Warning statement before proceeding and work carefully.

⚠ CAUTION

Text in a Caution box alerts you to a situation in which you could damage the refrigeration system. Read each Caution statement before proceeding and work carefully.

Disregarding these special notices may result in personal injury and/or damage to the refrigeration system.

Safety Notices:

- Installation and maintenance/servicing are to be performed only by trained and qualified personnel familiar with commercial refrigeration systems.
- Ensure that all field wiring conforms to the equipment requirements and all applicable local and national codes.
- Disconnect all power sources before installing the controller wiring.
- Disconnect all power sources before servicing the refrigeration equipment.
- Sheet metal and coil surfaces have sharp edges. Use appropriate protective gloves to prevent injury.
- Use appropriate eye protection during installation and servicing.

Condensing Unit Specifications

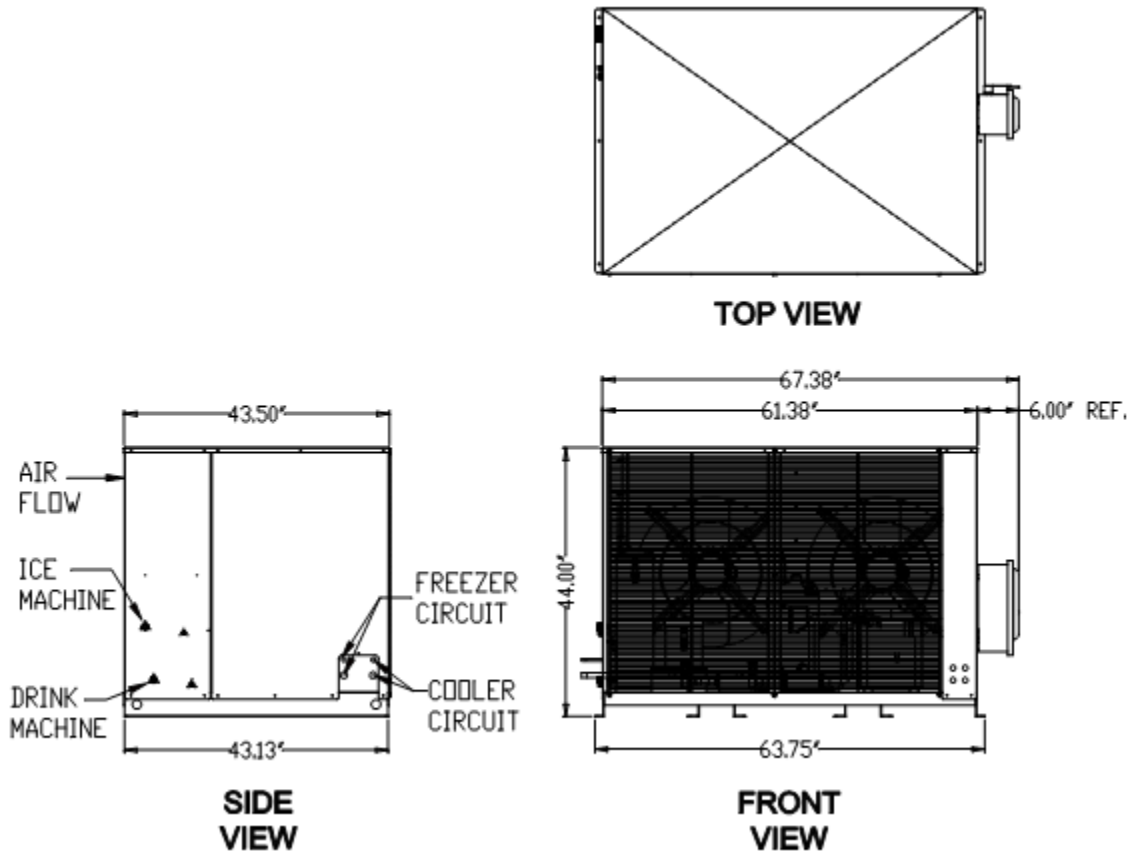

Model	Location	Compressor	Voltage	HP	MCA	MOP	Approx. Weight
MAC 7	FREEZER	ZF13K4E-TF5	208-230/3/60	4.5	31.3	40	660 lbs
	COOLER	CF04K6E-TF5	208-230/3/60	1.5			
MAC 8	FREEZER	ZF15K4E-TF5	208-230/3/60	5.5	38.8	50	660 lbs
	COOLER	CF04K6E-TF5	208-230/3/60	1.5			

MCA – Minimum Circuit Ampacity.

MOP – Maximum Overcurrent Protection.

Evaporator Unit Specifications

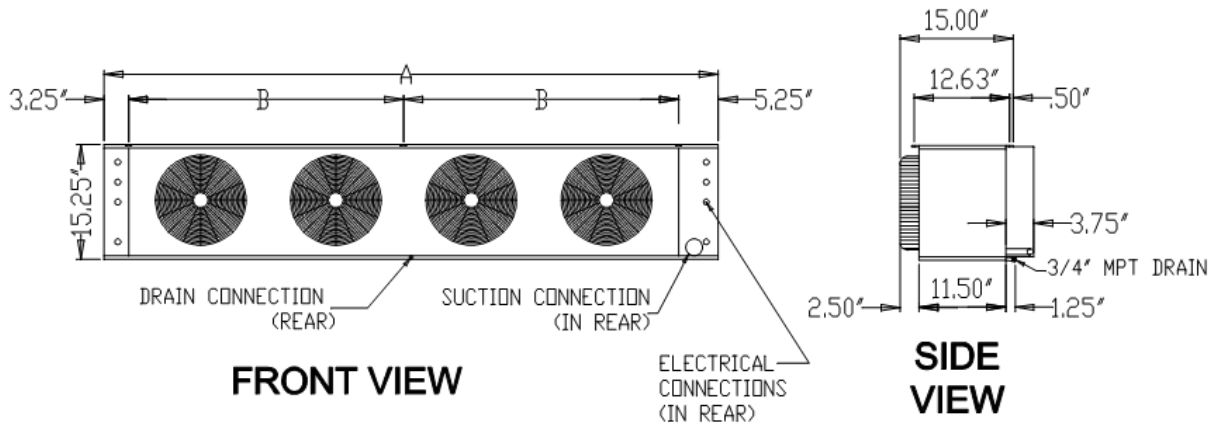

Model	Location	Evaporator Model	BTUH	No. of Fans	A	B	Suction OD	Liquid OD	Motor Amps	Heater Amps	Approx. Weight
MAC 7	FREEZER	EL36-140-2MAC	14,000	3	63.50	55.00	7/8"	3/8"	1.35	13.00	115 lbs
	COOLER	AM28-134-2MAC	13,400	2	45.50	37.00	7/8"	3/8"	0.90	n/a	77 lbs
MAC 8	FREEZER	EL46-185-2MAC	18,500	4	81.50	36.50	1-1/8"	3/8"	1.80	13.00	155 lbs
	COOLER	AM28-134-2MAC	13,400	2	45.50	37.00	7/8"	3/8"	0.90	n/a	77 lbs

Receiving Inspection

Check the shipment carefully and compare to the bill of lading. Account for all items listed and inspect each container for damage. Carefully inspect for any concealed damage. Report any shortages or damages to the carrier, note on the bill of lading, and file a freight claim.

Damaged material cannot be returned to the manufacturer without prior approval. A Return Material Authorization (RMA) must be obtained. Contact a sales representative at 800-826-7036.

Locating and Mounting Condensing Unit

General Guidelines:

- Check the selected installation location to ensure that racks, braces, flooring, foundations, etc. are adequate to support the condensing unit weight.
- The installation location is clean, dry, and level.
- Locate away from corrosive and noise sensitive atmospheres.
- Use the condensing unit skid and base when moving the unit. Do not remove unit from skid until the unit is moved to the mounting location.
- Mount the condensing unit base to pads or structural rails using properly sized bolts through the unit base.

WARNING

Do not lift the condensing unit by the refrigerant tubing or components. These features will not support the condensing unit weight. Injury and unit damage may occur!

CAUTION

Do not leave the condensing unit mounted to the wooden skid. This prevents all of the unit supports from contacting the mounting surface. Excessive vibration and premature equipment failure can occur.

Clearance Requirements:

- Locate where there is a sufficient and unrestricted supply of clean ambient air.
- Locate where there is adequate space for the removal of the heated discharged air from the condensing unit area.
- Do not position multiple units so that discharge air from one unit is blowing into the condenser inlet air of the other unit.
- All sides of the unit should be positioned a minimum distance equal to the total width of the condensing unit away from any other unit, wall, or obstruction.

Example of Multiple Units with Horizontal Airflow

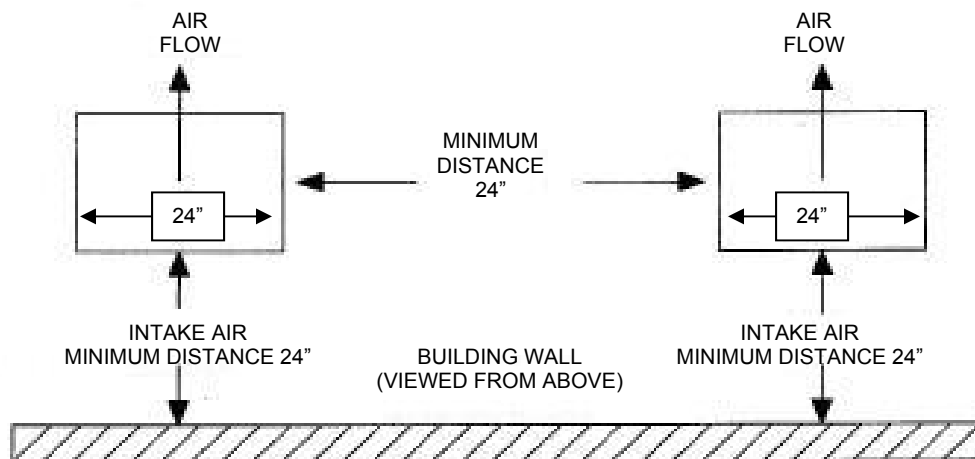

⚠ CAUTION

Failure to observe clearance and air flow requirements will result in poor system performance and premature equipment failure!

Locating and Mounting Evaporator Coil

General Guidelines:

- Do not place the evaporator above or close to door openings. This will help prevent potential icing problems.
- Allow a minimum clearance equal to or greater than the coil height on all sides of the coil for proper air flow and service access. This does not apply to fan side.
- Use the evaporator coil for a template to locate and drill the mounting holes (1/2" diameter).
- Place a 1" and a 1-5/8" washer on each nylon bolt and insert through the drilled mounting holes.
- Lift the evaporator coil until the nylon bolts extend through the mounting brackets.
- Install washers and secure with nuts. Tighten until the coil is firm against the ceiling. The evaporator coil must be level.
- Additional information is available in the installation manual supplied with the evaporator.

⚠ CAUTION

Failure to observe clearance and air flow requirements will result in poor system performance and premature equipment failure!

Evaporator Coil Mounting Diagram

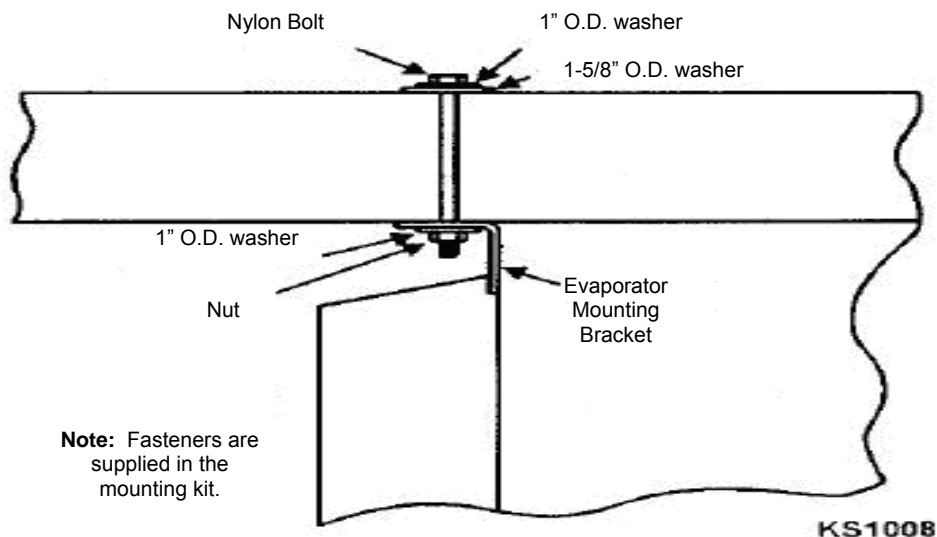

Wiring

All electrical connections and routing must comply with local and national codes. Do not modify the factory installed wiring without written factory approval. The field wiring must enter through the knockouts provided. Refer to the nameplate on the condensing or evaporator coil to determine the proper electrical power supply. Wire type should be of copper conductor only and properly sized to handle the electrical load. The unit and coil must be properly grounded. Condensing unit wiring diagrams are attached inside the electrical box cover. Evaporator coil wiring diagrams are located inside the evaporator end panel. Copies of the wiring diagrams are also available in the back of this manual.

WARNING

All wiring must comply with local and national codes. Wiring must be performed only by a refrigeration technician or certified electrician. Failure to follow these guidelines may result in injury!

CAUTION

Check all wiring connections, including factory terminals, before operation. Connections can become loose during shipment and installation.

Piping

General Requirements:

All refrigeration piping and components are to be installed in accordance with applicable local and national codes and in conformance with industry refrigeration guidelines to ensure proper operation of the refrigeration system. Only refrigeration grade copper tubing should be used. Long radius elbows should be used. Short radius elbows have points of excessive stress concentration and are subject to breaking at these points, do

not use short radius elbows. Suction lines must be insulated with a minimum 1" thick armaflex to reduce heat pick-up.

Cleanliness:

Condensing units and evaporator coils are cleaned and dehydrated at the factory. The condensing unit must remain closed and pressurized until the piping is complete and final connections are ready to be made.

CAUTION

The maximum air exposure for dehydrated condensing units is 15 minutes. Systems exposed longer than 15 minutes must have the compressor oil and drier filter replaced. Leaving a system exposed to the atmosphere for more than 15 minutes can result in premature system failure.

Note: PC model condensing units are supplied with a refrigerant charge. PR model condensing units are supplied with a dry holding charge.

Do not remove system tubing covers until work is ready to be performed. Ensure that all refrigeration tubing is clean and dry prior to installation. Use only tubing cutters when trimming tubing to the proper length. Do not use saws to cut tubing.

CAUTION

The use of saws to cut tubing can contaminate the system with copper chips causing premature system failure.

Brazing joints require a dry inert gas, typically nitrogen, be passed through the lines at a low pressure to prevent scaling and oxidation. Use only silver solder brazing alloys. Minimize the amount of flux to prevent internal contamination. Flux only the male portion of the joint. Thoroughly clean fluxed joints after brazing.

CAUTION

Dry inert gas must be passed through the system while brazing to prevent scaling and oxidation. Scaling and oxides can clog refrigeration components resulting in system failure.

Pipe Supports:

All tubing should be supported in a least two locations (near the end of each tubing run). Long runs will require additional support. As a guide, support 3/8" to 7/8" pipe every five feet, 1-1/8" to 1-3/8" every seven feet, and 1-5/8" to 2-1/8" every ten feet. Do not leave a corner unsupported when changing directions. Place supports within 2 feet of each direction change. Piping that is attached to a vibrating object (such as a compressor or

compressor base) must be supported in a manner that will not restrict the movement of the vibrating object. Rigid mounting will fatigue the tubing causing refrigerant leaks.

Oil Traps:

To ensure proper oil return to the compressor, a P-type oil trap should be installed at the base of each suction riser of four feet or more. The suction trap must be the same size as the suction line. Additional traps are necessary for long vertical risers. Add a trap for each length of pipe (approximately 20 feet) to insure proper oil return. Suction lines must slope $\frac{1}{4}$ " per 10 feet toward the compressor. Install a suction line trap at the evaporator outlet if the suction line rises to a point higher than the connection on the evaporator.

CAUTION

Failure to properly install oil traps can prevent sufficient oil return to the compressor resulting in premature compressor failure.

Drain Lines:

Evaporator coil drain lines should be pitched a minimum of $\frac{1}{2}$ " per foot to allow proper drainage and exit the walk-in as quickly as possible. Insulate and seal the drain line where it passes through the wall. Copper drain line is required. If the refrigerated space is 33°F or lower, drain line insulation and heat tape are required. Drain lines must be insulated with minimum $\frac{1}{2}$ " thick armafex. The drain line heat tape must be wrapped around the copper drain line. Do not locate bends, elbows, or drain traps within the refrigerated space. Do not reduce the drain line size. Locate a drain line P-trap outside of the refrigerated space. Any traps exposed to low ambient temperatures should be wrapped with a drain line heater (provide 20 watts of heat per foot of drain line at 0°F, 30 watts per foot at -20°F).

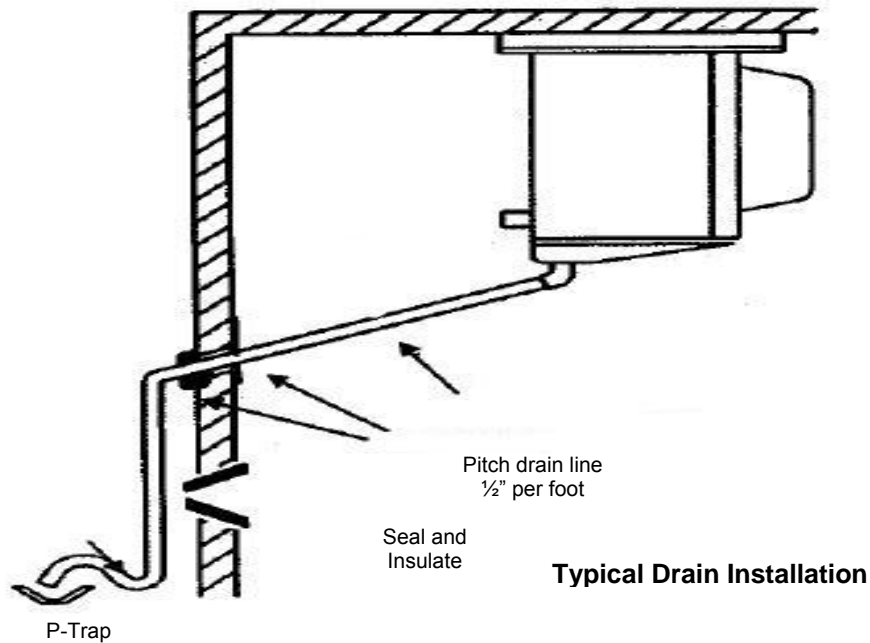

Leak Testing

After all connections are complete the refrigeration system must be tested for leaks. Failure to perform a leak test can result in unsatisfactory system performance, additional servicing and service costs, and possible system failure. Leak test should be performed using an electronic leak detector. All joints and components, both factory and field installed, should be thoroughly inspected for leaks. The system installation must be leak free!

Leak Testing "PR" model systems:

- Open both the liquid and suction service valves.
- Ensure the solenoid valve is energized and open.
- Add 50 psi refrigerant, then pressurize with dry nitrogen to the low side test pressure identified on the unit rating label.
- Allow thirty minutes for refrigerant to reach all parts of the system.
- Check all joints and components with an electronic leak detector.

Leak Testing "PC" model systems:

- Leave the service valves closed, the condensing unit is charged with refrigerant.
- Ensure the solenoid valve is energized and open.

- Add 50 psi refrigerant, then pressurize with dry nitrogen to the low side test pressure identified on the unit rating label.
- Allow thirty minutes for refrigerant to reach all parts of the system.
- Check all joints and components with an electronic leak detector.

If a leak is detected, relieve the pressure and/or reclaim the refrigerant and repair the leak. If additional brazing is required, pass a dry inert gas (nitrogen) through the system to prevent contamination. Retest the system as outlined above until no leaks are detected.

 **CAUTION**

If a braze joint is detected leaking, dry inert gas must be passed through the system while repairing the joint to prevent scaling and oxidation. Scaling and oxides can clog refrigeration components resulting in system failure.

 **CAUTION**

Always use the system specified refrigerant when pressuring to perform a leak test.

System Evacuation

Evacuation of the refrigeration system is necessary to remove all air and moisture from the system. A reliable rotary vacuum pump with an accurate deep vacuum gauge is recommended. Do not use the system compressor as a vacuum pump and do not operate the compressor while the system is under vacuum.

Evacuation of “PR” model systems:

- Open both the liquid and suction service valves.
- Ensure the solenoid valve is energized and open.
- Connect vacuum pump to the liquid and suction service valves.
- Evacuate the system to 250 microns and maintain for a minimum of 4 hours.
- Perform a vacuum decay test for a minimum of ten minutes to ensure the system is leak free and dry.

Evacuation of “PC” model systems:

- Leave the service valves closed, the condensing unit has been evacuated and is charged with refrigerant.
- Ensure the solenoid valve is energized and open.

- Connect vacuum pump to the liquid and suction service valves.
- Evacuate the system to 250 microns and maintain for a minimum of 4 hours.
- Perform a vacuum decay test for a minimum of ten minutes to ensure the system is leak free and dry.

⚠ CAUTION

Do not use the system compressor to evacuate the system. Do not start the compressor while the system is under vacuum. This may damage the compressor and cause premature system failure.

Refrigerant Charging

The refrigerant charge should be added to the system through the liquid line service valve. Do not charge liquid refrigerant into the suction service valve! The initial charge should be determined by weight and sight glass indication. Start the system. If the condensing temperature is 105° F or greater, charge the system until the sight glass clears. If the condensing unit temperature is below 105° F, reduce the condenser face surface area to raise the discharge pressures above 105° F and proceed to charge to a clear sight glass. Return to a full condenser face area when charging is complete.

⚠ CAUTION

Do not charge liquid refrigerant into the suction service valve. Do not overcharge the system. These conditions can permit liquid refrigerant to enter the compressor and cause damage to internal components resulting in premature system failure.

Note: PC model condensers are charged at the factory with 17 lbs. (freezer) and 8-1/2 lbs (cooler) of R404A refrigerant. Due to site variances, an additional charge may be required.

Operational Start-Up

The first 2 – 4 hours of operation after initial start-up is a critical time. Do not just start the system and leave. Pressure values, compressor and evaporator superheat, and inspecting for excessive vibrations and loose connections are some of checks that must be performed prior to leaving the system.

Pre-Start Checks:

- Verify that all service valves are fully open.
- Ensure that all refrigerant and electrical connections are tight.

- Verify that the wiring and piping is properly routed and secured.
- The compressor mounting bolts are properly adjusted.
- All fan motors and mounting brackets are tight.
- The condensing unit base and evaporator coil are properly secured.
- ArcticFox User Interface is properly installed and mounted.

Compressor Mounts:

Check the compressor mounting bolts to ensure the nuts have not become loose during shipment.

 **CAUTION**

Failure to ensure the compressor mounts are properly tightened can result in fatigue to the system piping causing leaks and poor system performance.

ArcticFox User Interface Installation and Initialization:

The user interface is designed to sit on the manager's desk, but can be field modified to mount directly to the walk-in or wall. The User Interface has a port on top for a CAT5e cable.

To mount the user interface to a vertical surface using the UI Wall Mounting Assembly:

- Select mounting location (allow 12" min. clearance for UI away from high traffic areas and protected from direct contact with liquids).
- Remove the backing from the (2) 2-1/2" long lengths of double sided tape located on the back of the assembly.
- Press the assembly onto the pre-selected mounting location surface ensuring the assembly is level and plumb.
- Secure the assembly to the vertical surface using (4) 10-16 x 1/2" self tapping screws.

Once the user interface is secured in its stationary location, connect the CAT5e cable from VFD-UI indicated on the evaporator coil to the UI ensuring the CAT5e cable is securely fastened to adjacent surfaces.

Once unit is powered up, the UI will begin the initialization process.

At initialization the Start-up screen is shown, followed by an Initialization screen, followed by the Main screen. The Start-up screen will flow directly into the main screen without user interaction.

The status bar is located at the top of the display and will continuously alternate through the status of the key parts of the system. These include:

- Unit State – (Idle, Idle-W, Cooling, Defrost)
- Door Status – (Open, Closed). Unit will read 'closed' if the door functionality is not utilized.
- Light Status – (On, Off). Unit will read 'off' if the light functionality is not utilized.
- Temperature set point – (35° F for coolers, -10° F for freezers).
- Alarms – Any alarm condition results in an audible alarm and visual alarm.

 **CAUTION**

If a cooler/freezer combo is operating from a single UI, connect additional factory supplied CAT5e cable from Optional Modules at the freezer evaporator to the Optional Modules at the cooler evaporator.

Set the time and date:

- Press the <Menu> button and enter password (default is AAAA)
- Enter password, then press <√>.
- Press <Down> to scroll to "Set Date & Time", then press <√>.
- Press <Up> or <Down> to select the hour, then press <√>
- Press SB2 (under next) to move on to the minute screen.
- Follow the steps above until the time and date are set, then press <√> to return to the Menu screen.
- Press <X> twice to return to main display.

Set the Manager Password:

- Press the <Menu> button
- Enter password, then press <√>.
- Press <Down> to scroll to "Set User Password", then press <√>.
- Enter old password (default is AAAA) and press <√>
- Enter new password and press <√>
- Re-enter new password and press <√>

- Press <X> twice to return to main display

Set the Service Password:

- Press the <Menu> button
- Enter password, then press <√>.
- Press <Down> to scroll to “Service Menu”, then press <√>.
- Press <Down> to scroll to “Set Service Password”, then press <√>.
- Enter old password (default is ZZZZ) and press <√>
- Enter new password and press <√>
- Re-enter new password and press <√>
- Press <X> three times to return to main display

Start-Up Procedure:

 **CAUTION**

Do not start the system while in a vacuum. Do not leave the system unattended until normal operating conditions are achieved.

Operate the system for a minimum of two hours and perform checks of the following:

- Check the compressor discharge and suction pressures to ensure they are in the normal operating range.
- Check the liquid line sight glass for proper refrigerant charge.
- Check the voltage and amperage at the compressor terminals. Voltage must be within +10% or -5% of the rating indicated on the condensing unit name plate. On three phase compressors, verify there is a balanced load.
- Check all fans on the evaporator coil and condensing unit to be sure they are operational and turning in the correct direction.
- Check the piping and electrical connections for vibration. Add supports and strapping if needed.
- Check the crankcase heater operation (if equipped).
- The defrost times and settings are pre-set and controlled by ArcticFox.
- Set temperature is pre-set and controlled by ArcticFox.

- Check the compressor and evaporator superheat (pages 21-22). Superheat is pre-set and controlled by ArcticFox.

After all system checks have been checked, properly adjusted, and verified, replace all Schrader caps, service valve caps, electrical box covers, housings, etc. File a copy of this manual for future reference.

Compressor Superheat:

 **CAUTION**

Failure to check and properly adjust compressor superheat can result in premature system failure.

Compressor superheat is a critical value that must be checked. Check the compressor superheat as follows:

- Determine the suction pressure at the suction service valve of the compressor.
- Determine the saturation temperature at the observed suction pressure using refrigeration pressure temperature tables.
- Measure the suction line temperature 6 -10 inches away from the compressor.
- Subtract the saturation temperature (step 2) from the measured temperature (step 3). The difference is the superheat of suction gas.

A low suction superheat can cause liquid to return to the compressor. This will cause dilution of the oil and eventual failure of the bearings, rings and valves. A high suction superheat will cause excessive discharge temperatures, which cause a breakdown of the oil. This causes piston ring wear, and piston and cylinder wall damage. System capacity decreases as the suction superheat increases. For maximum system capacity, keep the suction superheat as low as practical. Copeland requires a minimum compressor superheat of 20°F; however, to improve compressor life, 25°F to 40°F is

preferred. Adjust the superheat using the ArcticFox controller. Refer to “Evaporator Superheat” on the next page for more information.

Evaporator Superheat:

Check the evaporator superheat once the walk-in has reached the desired temperature. Generally, systems with a design temperature drop of 10°F should have an evaporator superheat value of 6° - 10°F on freezers and 8° - 12°F on coolers for maximum efficiency. The evaporator superheat is pre-set for 8°F at the factory.

To determine the evaporator superheat:

1. Measure the suction pressure at the evaporator outlet.
2. Convert the pressure to saturation temperature referencing a temperature-pressure chart.
3. Measure the temperature of the suction line near the EEV sensor. Do not remove the insulation from around the sensor.
4. Subtract the saturation temperature reading (step 2) from the measured temperature (step 3). The difference is the evaporator superheat.

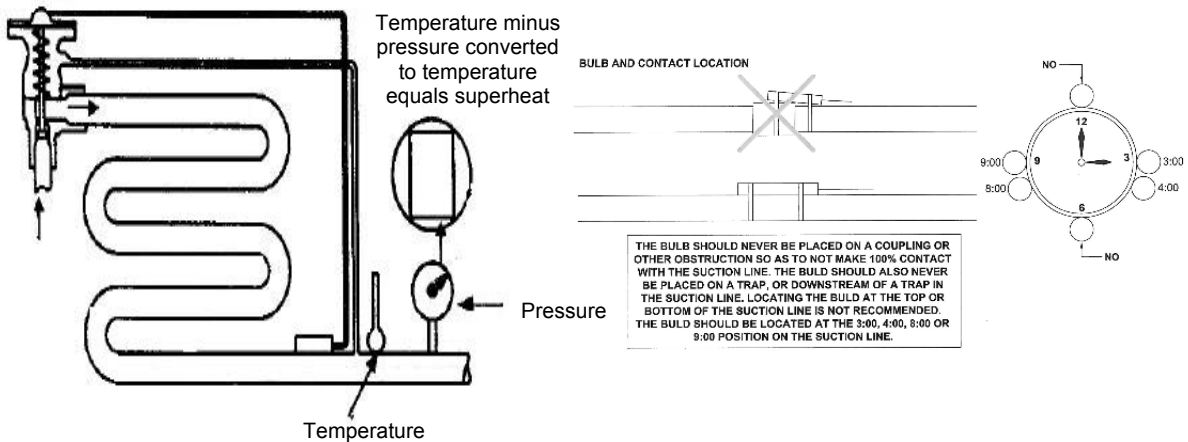

Determining Evaporator Superheat

CAUTION
 Minimum compressor superheat of 20°F may override these recommendations on systems with short line runs.

CAUTION
 The condensing unit must have the discharge pressure above the equivalent 105°F condensing pressure (reference refrigerant charging on page 17).

CAUTION
 Correct location and full contact of the EEV sensor is extremely important for proper system performance. EEV sensor is premounted and insulated before shipment.

ArcticFox Features

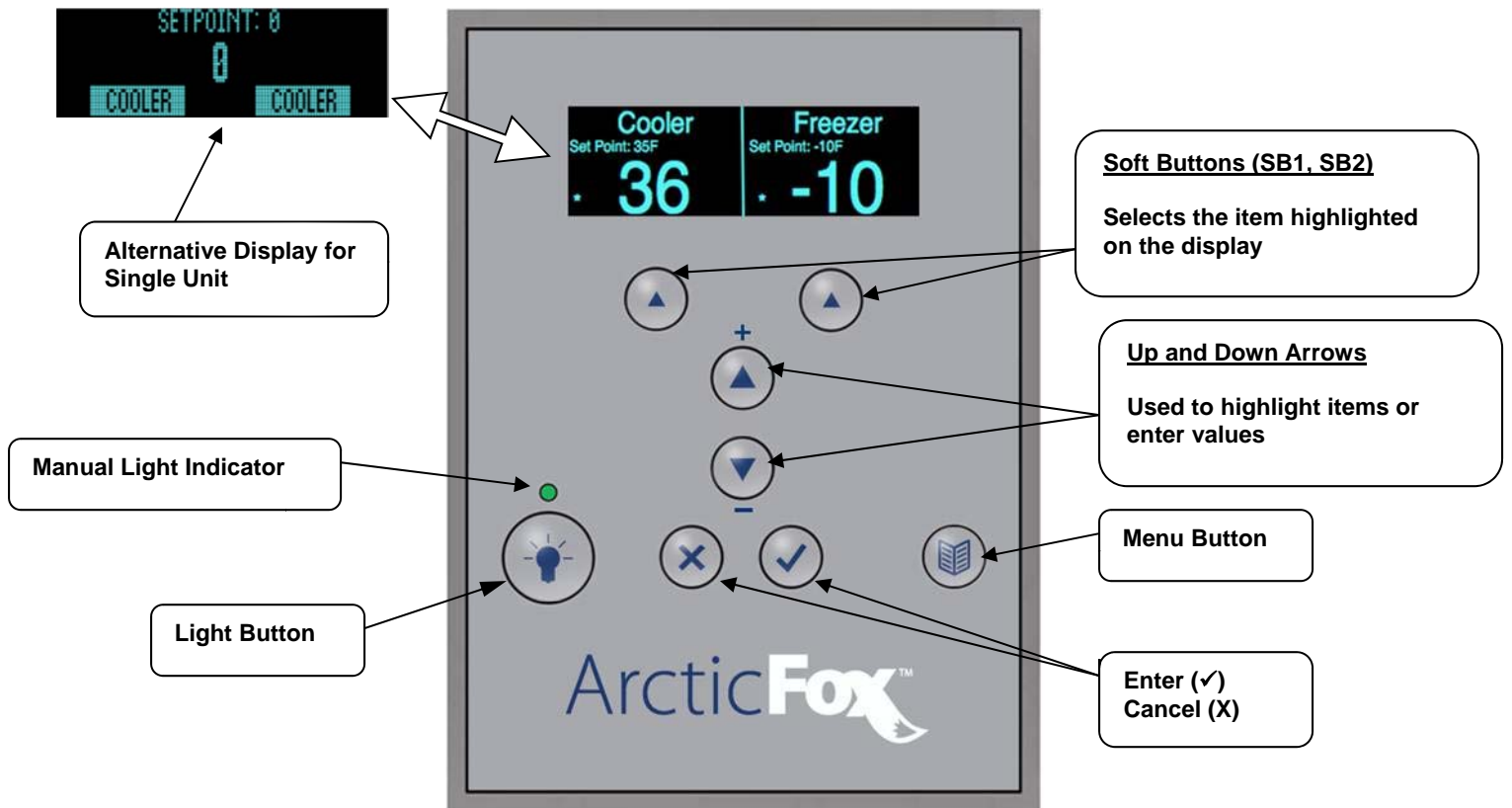

Note: Dual control mode shown

The ArcticFox Control System consists of a User Interface Control (Desk or wall mounted) and one or two evaporator coil assemblies with a factory mounted Smart Relay Board in each coil. The Smart Relay Board is factory configured to match the coil application (cooler or freezer). The User Interface Control is also referred to as the UI.

The standard features are shown below:

- Monitoring of the complete refrigeration system
- Programmable Operating Parameters
- Vacuum Fluorescence Display which shows:
 - Box temperature(s)
 - Set Point(s)
 - Alarm Conditions
- Data Logging (Flash Drive)
- Demand Defrost
- Audible Alarm
- Password Protection

Wiring:

All low voltage wiring must be run separate from line voltage:

User Interface Wiring

The ArcticFox User Interface does not require an external power source. The only connection to it is a CAT-5e cable that originates at the Evaporator Coil Assembly.

Evaporator Coil Wiring

The ArcticFox Smart Relay Board is mounted in each Evaporator Coil Assembly and controls:

- Refrigeration System
- Electric Expansion Valve
- Walk-In Cooler/Freezer Interior Light(s) - optional
- Walk-In Cooler/Freezer Door Heater(s) - optional
- Walk-In Cooler/Freezer Alarms

There are three terminal boards located in the Evaporator Coil Assembly used for field wiring:

Power Supply Terminal Block

The Power Supply Terminal Block must be supplied with 208-230/60/1 field connected power with ground. (See wiring diagram, Appendix E/F)

Terminal Block TB3, Low Voltage Wiring

Low voltage wiring is brought to terminal Block TB3 when optional Door Sensor Switches are used. It is recommended that 18 gauge wire be used. (See wiring diagram, Appendix E/F)

Terminal Block TB4 Wiring

When Door Heaters and/or Lights are to be controlled by ArcticFox, they must be wired to Terminal Block 4. (See wiring diagram, Appendix E/F)

Initialization of ArcticFox Control System:

When power is first applied to the ArcticFox User Interface, it checks the configuration of the system to which it is connected. If a Cooler/Freezer combo box is wired to it, the controller automatically connects. If the configuration is not a Cooler/Freezer combo box, refer to “set up” section for instructions to manually configure controller. This configuration can consist of the following options:

- One “Cooler” evaporator
- One “Freezer” evaporator
- One “Cooler/Freezer” combo, separate compartments

It is recommended (but not required) that the refrigeration system be operational before attaching the ArcticFox User Interface.

Button Functions:

- Light (☀) – This is used to turn on all of the lights that are wired into the Smart Relay Board(s). The Led indicator light reflects the status of the light button – not necessarily the actual light condition. Pushing the light button while the lights are on will shut them off (after the time delay expires). This does not apply when the lights are not controlled by the ArcticFox controller.
- System Selection Arrow (▲) – This is used to select the system to be programmed.
- Up, Down Arrows (▲, ▼) – These buttons are used to scroll through menus, parameters and settings.
- Cancel (X) – Depressing this button cancels the immediately preceding input.
- Enter (√) – Depressing this button “accepts” the immediately preceding input.
- Menu (☰) – Depressing this button brings up the main menu after the user enters and accepts the password.

Programming ArcticFox Control System:

Initial Set-Up:

The Smart Relay Board located in the Evaporator Coil Assembly is factory configured to match the Evaporator application (Cooler or Freezer). The UI is factory configured for a Cooler/Freezer combo box so no changes are required for this application.

To make a program change:

Select the appropriate application (Cooler or Freezer) by pressing the (▲) button below it.

- Enter password by scrolling (▲, ▼ arrows), selecting (▲), then entering (√)
- Set box temperature
- Set high temp alarm
- Set low temp alarm
- Set door alarm time (1 minute to 60 minutes)
- Clear alarms

Additional Program Changes:

To make additional changes or to view current settings available through different menus, press the menu button. Multiple pushes allow scrolling through the menu layers.

Program Changes:

➤ Main Menu (Manager's Menu)

- Information Menu
 - UI (VFD) Info
 - BT (Boot Table)
 - SW (Software Version)
 - BLD (Build Date)
 - VFD (Temperature)
 - DT (Current Date)
 - TM (Current Time)
 - Cooler Evaporator Info
 - BT (Boot Table)
 - SW (Software Version)
 - HW (Hardware Version)
 - MB (Modbus Version)
 - Freezer Evaporator Info (If Installed)
- Set Date and Time
- Set User Password
- **Service Menu**
 - **Cooler Service Menu**
 - Cooler Setup
 - ❖ Set Cooler Superheat – 4F to 20F
 - ❖ Set Cooler Hysterisis – 1F to 5F
 - ❖ Set Cooler Off Hysterisis – 1F to 5F
 - ❖ Cooler Door Sensor Enabled
 - None
 - Doors 1 or 2
 - Doors 1 and 2
 - Cooler Door Heater On Time – 0hr to 23hr 45 min.
 - Cooler Door Heater Off Time – 0hr to 23hr 45 min

Program Changes Continued:

- ❖ Set Light Max. On Time – 15min. to 120min.
- ❖ Set Light Delay After Door Close – 0min. to 120 min.
- ❖ Set Light Delay After Manual Off – 0min. to 120 min.
- ❖ Cooler Light Opera Mode – On/Off
- ❖ Cooler Enable Logging – Yes/No
- ❖ Cooler Initial Cool Down – On/Off
- ❖ Cooler Disable Temp Alarms – 1hr to 24hr
- Cooler Defrost Setup
 - ❖ Start Cooler Defrost – Yes/No
 - ❖ Select Cooler Defrost Mode – Electric/Air
 - ❖ Cooler Defrost Threshold – 0% to 99%
 - ❖ Cooler Defrost Calculation Start Temp – 0F to 20F
 - ❖ Cooler Defrost Timer Mode – Max Time No Defrost Compressor Run Time
 - ❖ Cooler Compressor Run Time Until Defrost – 100 min to 2880 min
 - ❖ Cooler Defrost Drip Time – 0 min to 5 min
 - ❖ Cooler Defrost Heater Delay – 0 min to 5 min
 - ❖ Cooler Fan Delay After Defrost – 0 min to 15 min
 - ❖ Cooler Defrost Max Temp – 40F to 70F
 - ❖ Cooler Max Defrost Time – 15 min to 120 min
 - ❖ Cooler Defrost Alarm Hold Off – 2 min to 120 min
- **Freezer Service Menu (Not Available if no Freezer)**
 - Freezer Setup
 - ❖ Set Freezer Superheat – 4F to 20F
 - ❖ Set Freezer Hysterisis – 1F to 5F
 - ❖ Set Freezer Off Hysterisis – 1F to 5F

Program Changes Continued:

- ❖ Freezer Door Sensor Enabled
 - None
 - Doors 1 or 2
 - Doors 1 and 2
 - Cooler Door Heater On Time – 0hr to 23hr 45 min.
 - Cooler Door Heater Off Time – 0hr to 23hr 45 min
- ❖ Set Light Max. On Time – 15min. to 120min.
- ❖ Set Light Delay After Door Close – 0min. to 120 min.
- ❖ Set Light Delay After Manual Off – 0min. to 120 min.
- ❖ Freezer Light Opera Mode – On/Off
- ❖ Freezer Enable Logging – Yes/No
- ❖ Freezer Initial Cool Down – On/Off
- ❖ Freezer Disable Temp Alarms – 1hr to 24hr
- Freezer Defrost Setup
 - ❖ Start Freezer Defrost – Yes/No
 - ❖ Select Freezer Defrost Mode – Electric/Air
 - ❖ Freezer Defrost Threshold – 0% to 99%
 - ❖ Freezer Defrost Calculation Start Temp – 0F to 20F
 - ❖ Freezer Defrost Timer Mode – Max Time No Defrost
Compressor Run Time
 - ❖ Freezer Compressor Run Time Until Defrost – 100
min to 2880 min
 - ❖ Freezer Defrost Drip Time – 0 min to 5 min
 - ❖ Freezer Defrost Heater Delay – 0 min to 5 min
 - ❖ Freezer Fan Delay After Defrost – 0 min to 15 min
 - ❖ Freezer Defrost Max Temp – 40F to 70F
 - ❖ Freezer Max Defrost Time – 15 min to 120 min
 - ❖ Freezer Defrost Alarm Hold Off – 2 min to 120 min

Program Changes Continued:

- VFD Tests
 - All Pixels On
 - All Pixels Off
 - Sound Alarm – Initiates Audible Alarm
 - Silence Alarm – Silences Alarm

- USB Menu
 - Load VFD Firmware
 - ❖ Select VFD Firmware
 - Load Cooler Evap Firmware
 - ❖ Select SRB Firmware
 - Load Freezer Evap Firmware
 - ❖ Select SRB Firmware

- Installed Modules
 - Is Cooler Evap Installed – Yes/No
 - Is Freezer Evap Installed – Yes/No

- Set Service Password
 - Enter Old Service Password
 - Enter New Password

 **CAUTION**

Firmware updates are supplied via zip drive from the factory. The zip drive containing the firmware must be connected to the UI usb port in order to 'Select Firmware'.

Alarm Codes:

If the ArcticFox User Interface sounds an audible alarm, it will display the visual alarm code in a shaded box above the box temperature display. Four types of alarms can be present:

- Sensor Failure – The audible alarm will sound when a sensor fails and the display will flash showing a 4 digit code that can be disseminated through the use of the table in Appendix A.
- Door Alarm – The audible alarm will sound if a freezer or cooler door is left open longer than the alarm delay setting.
- High Temp Alarm – The audible alarm will sound if the box temperature exceeds the alarm set point.
- Low Temp Alarm – The audible alarm will sound if the box temperature falls below the alarm set point.

The audible alarm can be silenced by pressing the (X) and (√) buttons simultaneously for three seconds. After alarm is silenced, it will beep every 30 seconds until alarm conditioned is cleared.

Sustaining Mode:

In the event of a sensor failure, the refrigeration system will revert to an automatically controlled sustaining mode. In this mode, the refrigeration system will continue to operate to keep the box at or near the temperature set point. This allows the user adequate time to obtain service to resolve the problem. Sensor failures must be addressed by an authorized service agent within 24 hours.

The audible alarm will sound and the display will flash a 4 digit code (see Appendix A). The system detects if a defrost is needed and may go into defrost mode displayed L-Defrost. When the system comes out of defrost mode and starts cooling, L-Cooling is displayed. When cooling stops, system goes into idle mode. L-Idle is displayed. This cycle is repeated while in sustaining mode. 'L' in front of mode is a quick indicator that system is operating in sustaining mode for 'limited operation' and authorized service agent must be contacted.

Data Logging:

The ArcticFox User Interface logs data when a flash stick is inserted into the USB port on the top of the control. Two types of data are logged, events and sensors. Events are logged when they occur and sensor data is logged every minute. This data is compiled and can be downloaded from the flash drive.

On Demand Defrost:

Through the use of a proprietary operating system, the ArcticFox Control continuously monitors the refrigeration system performance to determine the need for defrost. When the system performance drops below a predetermined efficiency, the ArcticFox Control initiates a defrost cycle. When the ArcticFox Control determines the coil is free of frost, defrost is terminated.

The ArcticFox Control can also be programmed to defrost at timed intervals and has a settable feature to allow for timed safety defrosts. This feature is available through the cooler or freezer “Defrost Setup” menu.

Anti-Short Cycle:

The ArcticFox control also has a built in feature to prevent short cycling. Once the compressor shuts down, the compressor can not come back on for 3 minutes.

System Defaults:

The following table lists the factory default settings for the ArcticFox Control. All of these settings are programmable through the ArcticFox User Interface.

Parameter	Default Setting	Brief Functionality Description
<u>FREEZER</u>		
Operator Password Screen	AAAA	Screen where user password is entered in order to access the parameters available in the Manager's menu. The password contains 4 alpha characters. The selection range on each character is A thru Z.
Set Freezer Temperature	-10°F	Temperature set point from which Hysteresis determines CI and CO Temps (Target Walk-in temperature set point)
Set Freezer High Temp Alarm	+10°F	High temperature alarm set point. Temperature at which the alarm initiates (after delay time has been satisfied)
Set Freezer Low Temp Alarm	-20°F	Low temperature alarm set point. Temperature at which the alarm initiates (after delay time has been satisfied)
Set Freezer Door Alarm Time	60 minutes	Door Open Alarm time delay set point. A door open alarm is initiated if the walk-in door remains open for longer than set point duration.
Clear Freezer Alarms	No	Silences audible alarm and clears all visual alarms
<u>COOLER</u>		
Operator Password Screen	AAAA	Screen where user password is entered in order to access the parameters available in the Manager's menu. The password contains 4 alpha characters. The selection range on each character is A thru Z.
Set Cooler Temperature	+35°F	Temperature set point from which Hysteresis determines CI and CO Temps (Target Walk-in temperature set point)
Set Cooler High Temp Alarm	+40°F	High temperature alarm set point. Temperature at which the alarm initiates (after delay time has been satisfied)
Set Cooler Low Temp Alarm	+30°F	Low temperature alarm set point. Temperature at which the alarm initiates (after delay time has been satisfied)
Set Cooler Door Alarm Time	60 minutes	Door Open Alarm time delay set point. A door open alarm is initiated if the walk-in door remains open for longer than set point duration.
Clear Cooler Alarms	No	Silences audible alarm and clears all visual alarms
<u>FREEZER</u>		
Service Menu		
Service Password Screen	ZZZZ	Screen where user password is entered in order to access the parameters available in the Service menu. The password contains 4 alpha characters. The selection range on each character is A thru Z.
Freezer Service Menu		
Freezer Setup		
Set Freezer Superheat	8°	Set point for the desired evaporator operating superheat
Set Freezer On Hyst	Pre-Set	Number of degrees above Freezer Temperature set point at which cooling cycle begins
Set Freezer Off Hyst	Pre-Set	Number of degrees below Freezer Temperature set point at which cooling cycle ends

Freezer Door Sensor Enables	1 & 2	Determines which door sensors are enabled for monitoring. None = No doors are enabled 1 = Door 1 sensor is enabled 2 = Door 2 sensor is enabled 1 & 2 = Both Door 1 and Door 2 sensors are enabled
Freezer Door Heater On Time	0:15	Time of day the door heater will turn On
Freezer Door Heater Off Time	0:15	Time of day the door heater will turn Off. NOTE: If equal to Door Heater On Time the heater will always be on.
Set Light Max On Time (optional)	120 minutes	Maximum time the interior lights will remain ON continuously regardless of the current door open/closed status and regardless if the light has been turned on manually.
Set Light Delay After DC (optional)	15 minutes	The time setting for the length of time the interior lights will remain ON (when lights have been activated ON by opening the door) after the door has been closed.
Set Light DLY After Man Off (optional)	15 minutes	The time setting for the length of time the interior lights will remain ON (when lights have been activated ON manually via the UI) after the lights have been manually turned off.
Freezer Enable Logging	Yes	When selected YES, data logging thru USB port on the UI will occur (if USB flash drive has been inserted).
COOLER		
Service Password Screen	ZZZZ	
Cooler Service Menu		
Cooler Setup		
Set Cooler Superheat	8°	Set point for the desired evaporator operating superheat
Set Cooler On Hyst	Pre-Set	Number of degrees above Freezer Temperature set point at which cooling cycle begins
Set Cooler Off Hyst	Pre-Set	Number of degrees below Freezer Temperature set point at which cooling cycle ends
Cooler Door Sensor Enables	1	Determines which door sensors are enabled for monitoring. None = No doors are enabled 1 = Door 1 sensor is enabled 2 = Door 2 sensor is enabled 1 & 2 = Both Door 1 and Door 2 sensors are enabled
Cooler Door Heater On Time	0:15	Time of day the door heater will turn On
Cooler Door Heater Off Time	0:15	Time of day the door heater will turn Off. NOTE: If equal to Door Heater On Time the heater will always be on.
Set Light Max On Time (optional)	120 minutes	Maximum time the interior lights will remain ON continuously regardless of the current door open/closed status and regardless if the light has been turned on manually.
Set Light Delay After DC (optional)	15 minutes	The time setting for the length of time the interior lights will remain ON (when lights have been activated ON by opening the door) after the door has been closed.
Set Light DLY After Man Off (optional)	15 minutes	The time setting for the length of time the interior lights will remain ON (when lights have been activated ON manually via the UI) after the lights have been manually turned off.
Cooler Enable Logging	Yes	When selected YES, data logging thru USB port on the UI will occur if USB flash drive has been inserted.

FREEZER		
Freezer Defrost Setup		
Start Freezer Defrost Now	No	When YES is user selected, a manual defrost is initiated. This function operates independently of any other defrost functionality settings and only works one time per command.
Select Freezer Defrost Mode	Electric	Determines the type defrost system that the unit cooler utilizes. For a freezer application, the only setting available is Electric.
Freezer Defrost Threshold	Pre-Set	Defrost Effectiveness Threshold (DET) .This setting value represents the percentage (%) the evaporator effectiveness will decline before a "demand defrost" is triggered to initiate. (the higher the DET % value the more frost that will be allowed to accumulate on the evaporator coil)
Freezer Defrost Calc Temp Start	Pre-Set	This setting value is added to the temperature set point value and the sum is the temperature (during the compressor ON cycle) used to dictate whether the effectiveness calculations are being calculated or not being calculated. If the evap Air IN temperature is above the sum value, the effectiveness calculations stop calculating. If the evap Air IN temperature is at or below the sum value, the effectiveness calculations start calculating.
Freezer Defrost Timer Mode	CCRT	Max Continuous Compressor Run Time. (CCRT) This setting determines the safety defrost activation mode.
Freezer Comp Run Time Till Defrost	Pre-Set	This setting value is only active if the "Continuous Compressor Run Time" mode has been selected for the Safety Defrost operation. If the compressor runs continuously for the time that has been set, the system will automatically go into a defrost.
Freezer Defrost Drip Time	Pre-Set	This is the delay time for water to drip from the evap coil. When the defrost heaters turn off, the delay time starts and when the delay time expires the compressor will turn on.
Freezer Defrost Heater Delay	Pre-Set	This is the delay time after a defrost has been triggered to activate before the defrost heaters will be turned on. (allows time for the compressor to pump down and shut off before the heaters come on)
Freezer Fan Delay After Defrost	Pre-Set	This is the delay time after the drip time has expired before the evaporator fans turn ON. (the compressor starts to run at the beginning of this delay period) Any residual moisture that is left on the evap coil surface after the drip time period will be frozen before the evap fans come on.
Freezer Defrost Max Temp	Pre-Set	This is the temperature at which a defrost cycle will be terminated by temperature.
Freezer Max Defrost Time	Pre-Set	This is the length of time after which a defrost cycle will be terminated by time if the defrost cycle has not already been terminated on temperature.
		NOTE: The unit cooler also employs a fixed setting mechanical Heater Safety thermostat that can terminate the defrost cycle if for some reason the defrost cycle is not terminated on temperature or time via the ArcticFox controller.
Freezer Defrost Alarm Hold Off	Pre-Set	The delay time in minutes after a defrost cycle has ended before a high temp alarm can occur.

COOLER		
Cooler Defrost Setup		
Start Cooler Defrost Now	No	When YES is user selected, a manual defrost is initiated. This function operates independently of any other defrost functionality settings and only works one time per command.
Select Cooler Defrost Mode	Air	Determines the type defrost system that the unit utilizes. NOTE: Defrost termination for "Air Defrost Mode" is always terminated based on time. Defrost termination for "Electric Defrost Mode" is by temp. or time on a first achieved basis.
Cooler Defrost Threshold	Pre-Set	Defrost Effectiveness Threshold (DET). This setting value represents the percentage (%) the evaporator effectiveness will decline before a "demand defrost" is triggered to initiate. (the higher the DET % value the more frost that will be allowed to accumulate on the evaporator coil)
Cooler Defrost Calc Temp Start	Pre-Set	This setting value is added to the temperature set point value and the sum is the temperature (during the compressor ON cycle) used to dictate whether the effectiveness calculations are being calculated or not being calculated. If the evap Air IN temperature is above the sum value, the effectiveness calculations stop calculating. If the evap Air IN temperature is at or below the sum value, the effectiveness calculations start calculating.
Cooler Defrost Timer Mode	CCRT	Max Continuous Compressor Run Time. (CCRT) This setting determines the safety defrost activation mode.
Cooler Comp Run Time Till Defrost	Pre-Set	This setting value is only active if the "Continuous Compressor Run Time" mode has been selected for the Safety Defrost operation. If the compressor runs continuously for the time that has been set, the system will automatically go into a defrost.
Cooler Defrost Drip Time	Pre-Set	This is the delay time for water to drip from the evap coil. When the defrost heaters turn off, the delay time starts and when the delay time expires the compressor will turn on. Only active if electric defrost mode has been selected.
Cooler Defrost Heater Delay	Pre-Set	This is the delay time after a defrost has been triggered to activate before the defrost heaters will be turned on. (allows time for the compressor to pump down and shut off before the heaters come on). Only active if electric defrost.
Cooler Fan Delay After Defrost	Pre-Set	This is the delay time after the drip time has expired before the evaporator fans turn ON. (the compressor starts to run at the beginning of this delay period) Any residual moisture that is left on the evap coil surface after the drip time period will be frozen before the evap fans come on. NOTE: Only active if electric defrost mode has been selected.
Cooler Defrost Max Temp	Pre-Set	This is the temperature at which a defrost cycle will be terminated by temperature. Only active if electric defrost.
Cooler Max Defrost Time	Pre-Set	This is the length of time after which a defrost cycle will be terminated by time if the defrost cycle has not already been terminated on temperature. In Air Defrost Mode, the Off cycle air defrost will always terminate on time.
		NOTE: The unit cooler (electric defrost model only) also employs a fixed setting mechanical Heater Safety thermostat that can terminate the defrost cycle if for some reason the defrost cycle is not terminated on temperature or time via the ArcticFox controller.

Cooler Defrost Alarm Hold Off	Pre-Set	The delay time in minutes after a defrost cycle has ended before a high temp alarm can occur.
-------------------------------	----------------	---

Parts List:

The following is the parts list of items that can be serviced. The user interface is not serviceable and if damaged, must be replaced as a unit. If the Smart Relay Board must be replaced, proper ESD handling procedures must be followed.

Evaporator Part Description	Part Number
Wall Mounting Bracket	550003550
User Interface	550002636
Smart Relay Boards	Cooler - 550002640-SRB-MAC-C Freezer - 550002640-SRB-MAC-F
Electric Expansion Valve	550002639
Electric Expansion Valve Cable 10' with connector	550003062
Terminal Block, 32 position	550002641
Transformer	550002642
Wire Harness, 78" Transformer	550002650
Wire Harness, 132" Transformer	550003044
Wire Harness, 24" Temp Sensor	550002643
Wire Harness, 72" Temp Sensor	550002644
Wire Harness, 132" Temp Sensor	550002645
Pressure Transducer	550002646
Fuse, .250A, 250V	550002655
Cable, CAT-5e (2') Extension	550003057
Bracket, CAT-5e connector	550003060
Fuse Holder	550002656
CAT5E Cable (50')	550002651
CAT5E Cable (100')	550003182
CAT5E Cable (200')	550003783
CAT5E Cable (300')	550003784
Wire Harness, 72" Transducer	550002647
Wire Harness, 132" Transducer	550002658
Wire Harness, 168" Transducer	550002659

MAC 7 & MAC 8 Condensing Units	
Condensing Unit Part Description	Part Number
Compressor CF04K6E-TF5 208-230/3/60 (MAC 7 & 8, CLR)	550002804
Compressor ZF13K4E-TF5 208-230/3/60 (MAC 7, FZR)	030000978
Compressor ZF15K4E-TF5 208-230/3/60 (MAC 8, FZR)	030001789
Low Pressure Switch (MAC 7 & 8, CLR)	030001344
High Pressure Switch	030001347
Low Pressure Control (MAC 7 & 8, FZR)	550003572
3/8 Check Valve (MAC 7 & 8, CLR)	550004787
1/2 Check Valve (MAC 7 & 8, FZR)	550004788
Compressor Contractor	11167R
Defrost Lockout Relay (MAC 7 & 8, FZR)	550003755
Pump Down Relay (MAC 7 & 8, FZR)	550003755
Head Pressure Control Valve (MAC 7 & 8, CLR)	550003791
Head Pressure Control Valve (MAC 7 & 8, FZR)	550003793
Fan Contactor R1, R2, R3, R4	12164C
Condenser Fan Motor	550003547
Condenser Fan Motor Capacitor	550003548
Condenser Fan Blade	550003573
Condenser Fan Motor Mounting Bracket	550002621
Wire Grille	550003790

Maintenance

Maintenance Chart

Area	Task	Frequency
Evaporator	Check for proper defrosting	Monthly
	Clean the coil and drain pan	Every 6 months
	Check for proper drainage	
Condenser	Inspect /clean the coil if the air supply is near polluting sources (such as cooking appliances)	Monthly
	Clean the coil surface	Every 3 months
General	Check/tighten all electrical connections	Every 6 months
	Check all wiring and insulators	
	Check contactor for proper operation and contact point deterioration	
	Check all fan motors	
	Tighten fan set screws, and motor mount nuts and bolts	
	Check the operation of the control system	
	Make certain all safety controls are operating properly	
	Check operation of the drain line heater and examine for cuts and abrasions	
Check/tighten all mechanical/flare connections		

CAUTION

Failure to keep the condenser coil clean will result in reduced airflow through the condenser, resulting in poor system performance and premature compressor failure.

Polyol Ester (POE) Lubricants:

Polyol Ester (POE) lubricants quickly absorb moisture from the ambient surroundings. POE lubricants absorb moisture more rapidly and in greater quantity than conventional mineral oils. Because moisture levels greater than 100 PPM will result in system corrosion and component failure, it is essential that system exposure to ambient conditions be kept to a minimum.

If a system is left open to the atmosphere for more than 15 minutes, the liquid line drier and compressor oil must be replaced. Drain at least 95% of the oil from the compressor suction port. Measure the amount of removed oil, and replace it with exactly the same amount of new POE oil.

Mobil EAL™ ARCTIC 22 CC is the preferred Polyol Ester lubricant because of its particular additives. ICI Emkarate RL 32S is an acceptable alternative when the Mobil is not available. These POE lubricants must be used with HFC refrigerants. Lubricants are packaged in specially designed, sealed containers. Once opened, use the lubricant immediately. Properly dispose of any unused lubricant.

Notes:

Warranty Information

For information regarding warranty guidelines, claim form, product registration, warranty verification, or locating a service provider please visit our website at www.manitowocfoodservice.com or call 1-800-225-9916.



System Start-Up Data Sheet

A permanent data sheet must be prepared on each installation. A completed copy should be retained with this manual.

System Reference Data

The following information should be filled out and signed by Refrigeration Installation Contractor:

Date System Installed: _____ / _____ / _____

Installer and Address: _____

Phone Number: (____) _____ - _____

Service Agency: _____

Phone Number: (____) _____ - _____

Condensing Unit: Model Number: _____
Serial Number: _____

Compressor Model Number: _____ Compressor Model Number: _____

Compressor Serial Number: _____ Compressor Serial Number: _____

Electrical: _____ Volts: _____ Phase: _____

Voltage at Compressor: L1: _____ L2: _____ L3: _____

Amperage at Compressor: L1: _____ L2: _____ L3: _____

Evaporator(s): Quantity: _____

Evaporator Model Number: _____ Evaporator Model Number: _____

Evaporator Serial Number: _____ Evaporator Serial Number: _____

Electrical: _____ Volts: _____ Phase: _____

Expansion Valve Manufacturer/Model Number: _____

Ambient at Start-Up: _____ °F

Design Box Temperature: _____ °F _____ °F

Operating Box Temperature: _____ °F _____ °F

Thermostat Setting: _____ °F _____ °F

Defrost Settings: _____/day _____ minutes failsafe _____/day _____ minutes failsafe

Compressor Discharge Pressure: _____ PSIG _____ PSIG

Compressor Suction Pressure: _____ PSIG _____ PSIG

Suction Line Temperature at Compressor: _____ °F _____ °F

Discharge Line Temperature at Compressor: _____ °F _____ °F

Superheat at Compressor: _____ °F _____ °F

Suction Line Temperature at Evaporator: _____ °F _____ °F

Superheat at Evaporator: _____ °F _____ °F

Evacuation: # Times _____ Final Micron _____ # Times _____ Final Micron _____

Evaporator Drain Line Trapped Outside of Box: Yes No

Appendix A – Sensor Failure Codes:

UI Error Code Value	ARCTICFOX SENSOR FAILURE SCENARIOS
0001	Pressure Sensor Failure
0002	Coil Air In Sensor Failure
0004	Coil Air Out Sensor Failure
0008	Evap Out (suct. Line) Temp Sensor Failure
0010	Defrost Termination Sensor Failure
0003	Pressure Sensor Failure Coil Air In Sensor Failure
0005	Pressure Sensor Failure Coil Air Out Sensor Failure
0006	Coil Air In Sensor Failure Coil Air Out Sensor Failure
0007	Pressure Sensor Failure Coil Air In Sensor Failure Coil Air Out Sensor Failure
0009	Pressure Sensor Failure Evap Out (suct. Line) Temp Sensor Failure
000A	Coil Air In Sensor Failure Evap Out (suct. Line) Temp Sensor Failure
000B	Pressure Sensor Failure Coil Air In Sensor Failure Evap Out (suct. Line) Temp Sensor Failure
000C	Coil Air Out Sensor Failure Evap Out (suct. Line) Temp Sensor Failure
000D	Pressure Sensor Failure Coil Air Out Sensor Failure Evap Out (suct. Line) Temp Sensor Failure
000E	Coil Air In Sensor Failure Coil Air Out Sensor Failure Evap Out (suct. Line) Temp Sensor Failure
000F	Pressure Sensor Failure Coil Air In Sensor Failure Coil Air Out Sensor Failure Evap Out (suct. Line) Temp Sensor Failure
0011	Pressure Sensor Failure Defrost Termination Sensor Failure
0012	Coil Air In Sensor Failure Defrost Termination Sensor Failure
0013	Defrost Termination Sensor Failure Pressure Sensor Failure Coil Air In Sensor Failure

Appendix A – Sensor Failure Codes Continued:

UI Error Code Value	ARCTICFOX SENSOR FAILURE SCENARIOS
0014	Coil Air Out Sensor Failure Defrost Termination Sensor Failure
0015	Coil Air Out Sensor Failure Defrost Termination Sensor Failure
0016	Coil Air In Sensor Failure Coil Air Out Sensor Failure Defrost Termination Sensor Failure
0017	Defrost Termination Sensor Failure Pressure Sensor Failure Coil Air In Sensor Failure Coil Air Out Sensor Failure
0018	Evap Out (suct. Line) Temp Sensor Failure Defrost Termination Sensor Failure
0019	Evap Out (suct. Line) Temp Sensor Failure Defrost Termination Sensor Failure Pressure Sensor Failure
001A	Coil Air In Sensor Failure Evap Out (suct. Line) Temp Sensor Failure Defrost Termination Sensor Failure
001B	Evap Out (suct. Line) Temp Sensor Failure Defrost Termination Sensor Failure Pressure Sensor Failure Coil Air In Sensor Failure
001C	Coil Air Out Sensor Failure Evap Out (suct. Line) Temp Sensor Failure Defrost Termination Sensor Failure
001D	Coil Air Out Sensor Failure Evap Out (suct. Line) Temp Sensor Failure Defrost Termination Sensor Failure Pressure Sensor Failure
001E	Coil Air In Sensor Failure Coil Air Out Sensor Failure Evap Out (suct. Line) Temp Sensor Failure Defrost Termination Sensor Failure
001F	Pressure Sensor Failure Coil Air In Sensor Failure Coil Air Out Sensor Failure Evap Out (suct. Line) Temp Sensor Failure Defrost Termination Sensor Failure

Appendix B - Cooler or Freezer Setup:

The table below lists the items contained in the SETUP menu and their use.

Item Name	Range Increment	Contents
Superheat	4F – 20F	Sets the target Superheat for the unit
On Hysteresis	Pre-Set	Number of degrees above the set point where the cooling cycle will re-start
Off Hysteresis	Pre-Set	Number of degrees below the set point where the cooling cycle will end
Door Heater On Time	0hr – 23:45hr (15min steps)	The Time-Of-Day the door heater will turn on
Door Heater Off Time	0hr – 23:45hr (15min steps)	The Time-Of-Day the door heater will turn off (If equal to Door Heater On Time then the heater is always on)
Set Light on Max time	15-120 min (1 min steps)	Maximum time the inside lights will be on regardless of manual or door status
Set Light off Delay After Door Close	0-120 min (1 min steps)	Length of time to wait after the door closed before turning off the lights
Set Light Off Delay After Manual Off	0-120 min (1 min steps)	Length of time to wait after the Manual Light is turned off before turning the lights off.
Set Light Opera Mode	On/Off	Flash lights 5 times 1 minute before turning them off to give fair warning to anyone inside the unit. Must be off if fl. lights are used
Logging Enabled	YES/NO	Enables logging ONLY IF a USB flash drive is inserted

Note: Light functionality is only available if the lights are controlled by ArcticFox controller.

Appendix C - Defrost Setup:

The Table below lists the configurable parameters associated with the Defrost for either the Cooler or Freezer.

Item Name	Range/ Increment	Contents
Start Defrost (manual)	No/Yes	Start a cooler defrost cycle outside of the normally scheduled/calculated defrost
Defrost Mode	Electric/Air	Air or Electric
Defrost Threshold (%)	0 – 99 % (1% steps)	This number set the threshold (%) that must occur before the demand defrost will activate. Higher number mean more frost will accumulate
Defrost Safety Timer Mode	Pre-Set	There are two modes for the safety timer. 1) Time between defrosts 2) Continuous Compressor Run Time
Defrost Safety Timer	Pre-Set	There are two meanings for this time and the meaning is selected by the Defrost Safety Timer Mode (See above) 1) Maximum number of minutes between defrosts. After a manual defrost or Demand defrost the counter starts at zero. 2) Maximum number of minutes of continuous compressor run time before the system is forced to defrost. The counter is cleared when a cooling cycle ends
Defrost Drip Time	Pre-Set	Number of minutes to wait after heaters turn off before compressor turns on.
Defrost Fan On delay	Pre-Set	Number of minutes to wait after the drip time ends before allowing the fans to restart.
Defrost Max Temp	Pre-Set	This is the temperature at which the defrost cycle is terminated
Defrost Max Time	Pre-Set	This is the maximum number of minutes the defrost cycle will run
Defrost Heater Delay	Pre-Set	Delay between the start of the defrost and the time the electric heater is started. This allows the compressor to pump-down
Defrost Calc start Temp	Pre-Set	This value determines when the demand defrost calculation is started during the cooling cycle. Higher values start the calculation earlier but may cause false defrosts
Defrost Alarm Hold-off	Pre-Set	Hold time after defrost before a high temp alarm can occur. This allows the cooling cycle to cool the evaporator before testing for high temperature violations

Appendix D – Condensing Unit Wiring Diagram:

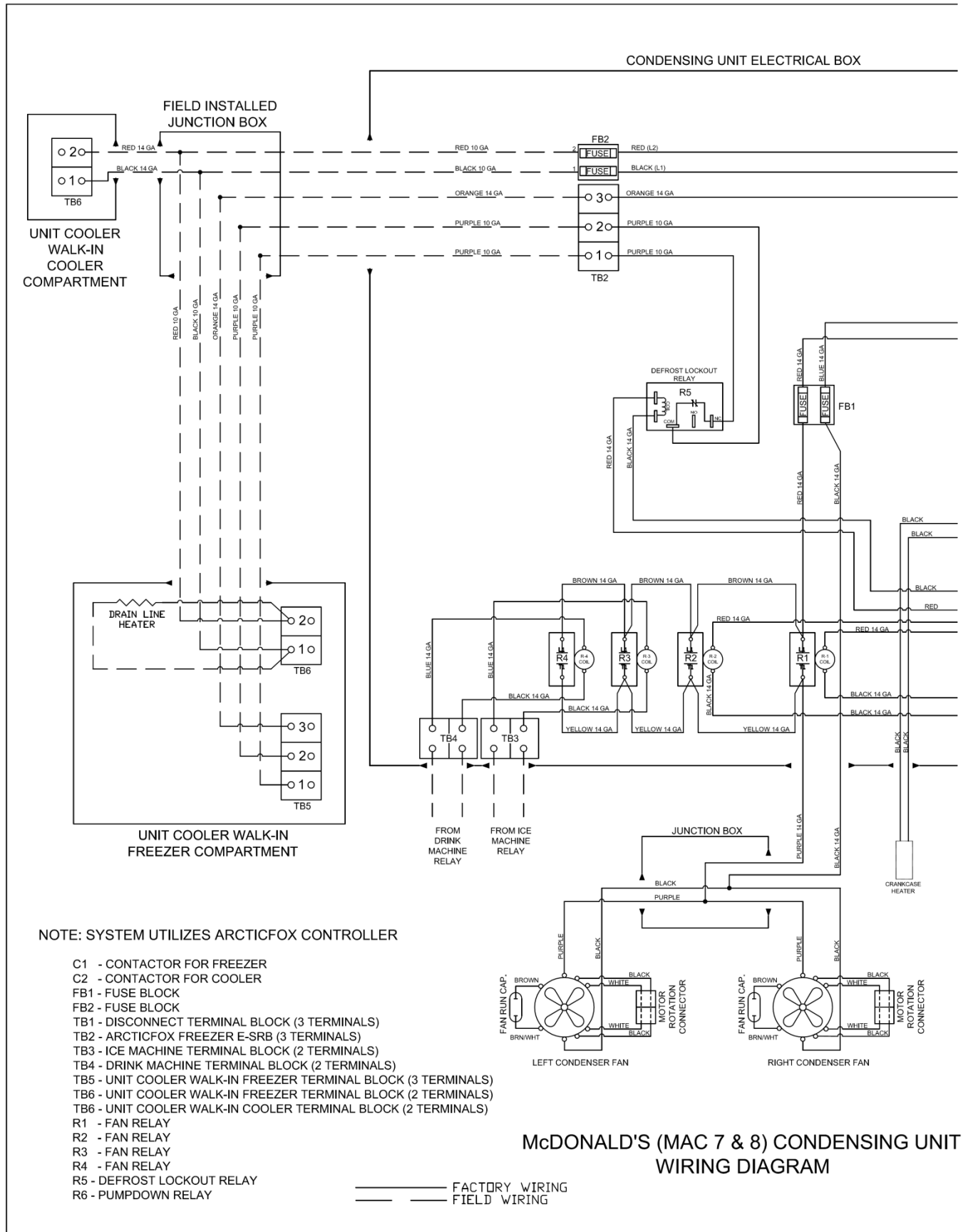

Appendix E – Air Defrost Wiring Diagram:

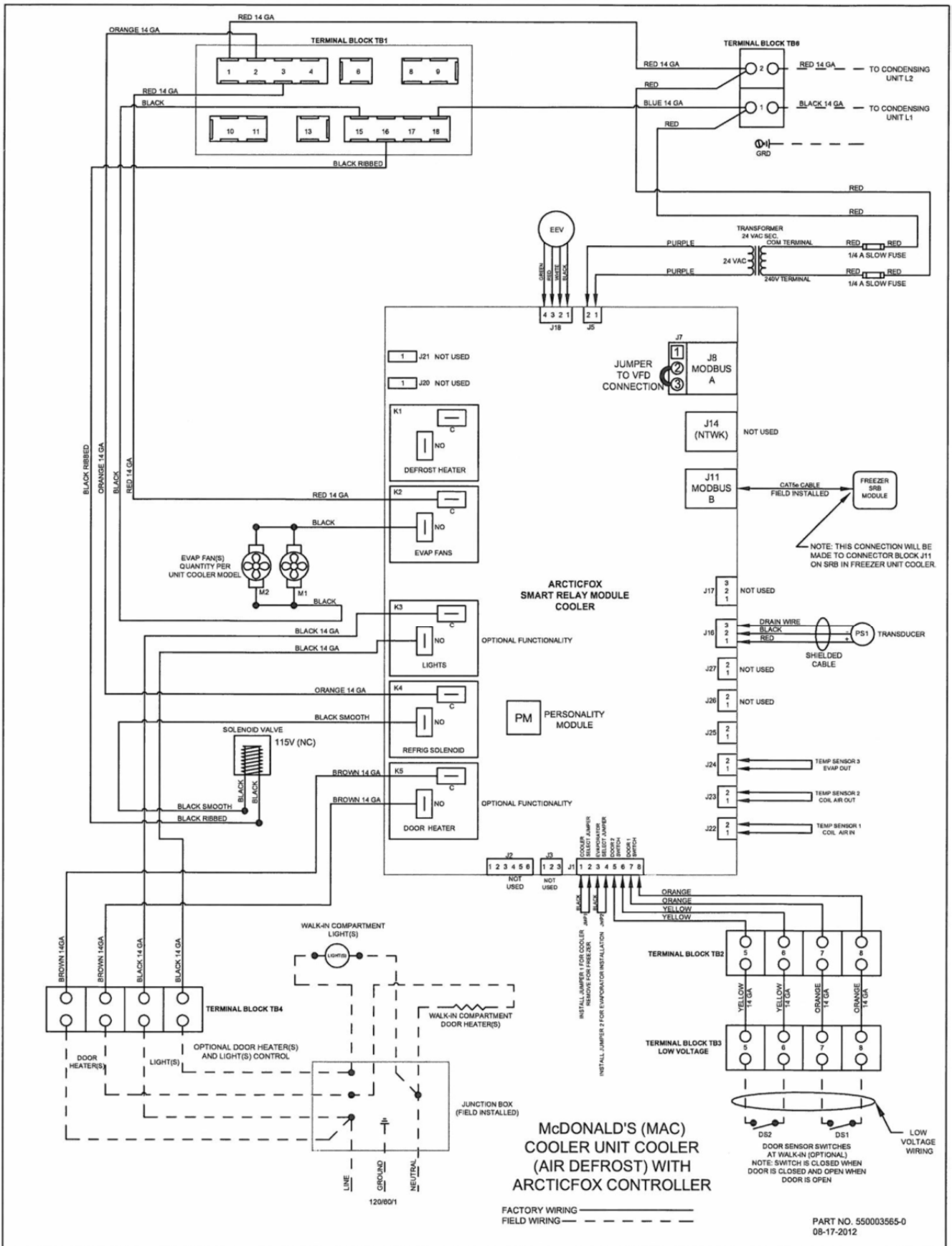

Appendix F – Electric Defrost Wiring Diagram:

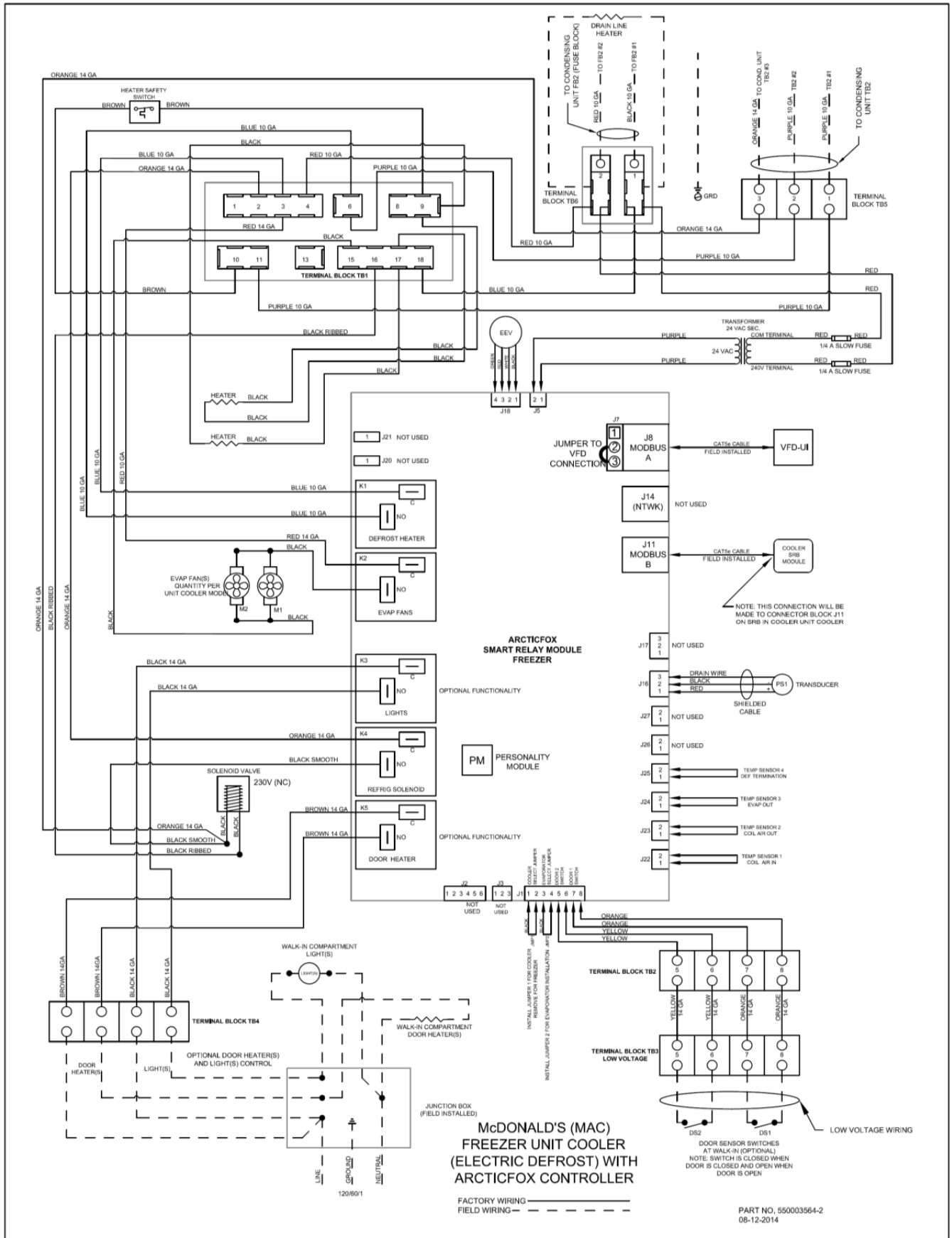

Appendix H – Standard Partition Door Section Wiring:

