



Joetap™

cold brew coffee tap systems

2060 Cessna Drive
Suite 100
Vacaville, CA 95688
www.joetap.com
**TECHNICAL SUPPORT:
707-448-5151**

JOETAP MODEL:

JT-NIT-RTD-4444

ULINE COOLER MODEL:

JADE524-SS03A

SYSTEM REQUIRES USE OF COMPRESSED NITROGEN FOR PROPER OPERATION. NITROGEN CAN BE SUPPLIED VIA NITROGEN GENERATOR OR COMPRESSED GAS CYLINDERS. NITROGEN SUPPLY DIAGNOSTICS ARE NOT COVERED IN THIS MANUAL.

PRECAUTIONS AND GENERAL INFORMATION

This appliance is intended for commercial use only and is intended for use in dispensing brewed beverage products for human consumption. No other use is recommended or authorized by the manufacturer or its agents.

This appliance is intended for use in commercial establishments, where all operators are familiar with the appliance use, limitations and associated hazards. Operating instructions and warnings must be read and understood by all operators and users.

Except as noted, this piece of equipment is made in the USA and has American sizes on hardware. All metric conversions are approximate and can vary in size.

The following trouble shooting, component views and parts lists are included for general reference, and are intended for use by qualified service personnel.



SYSTEM OVERVIEW

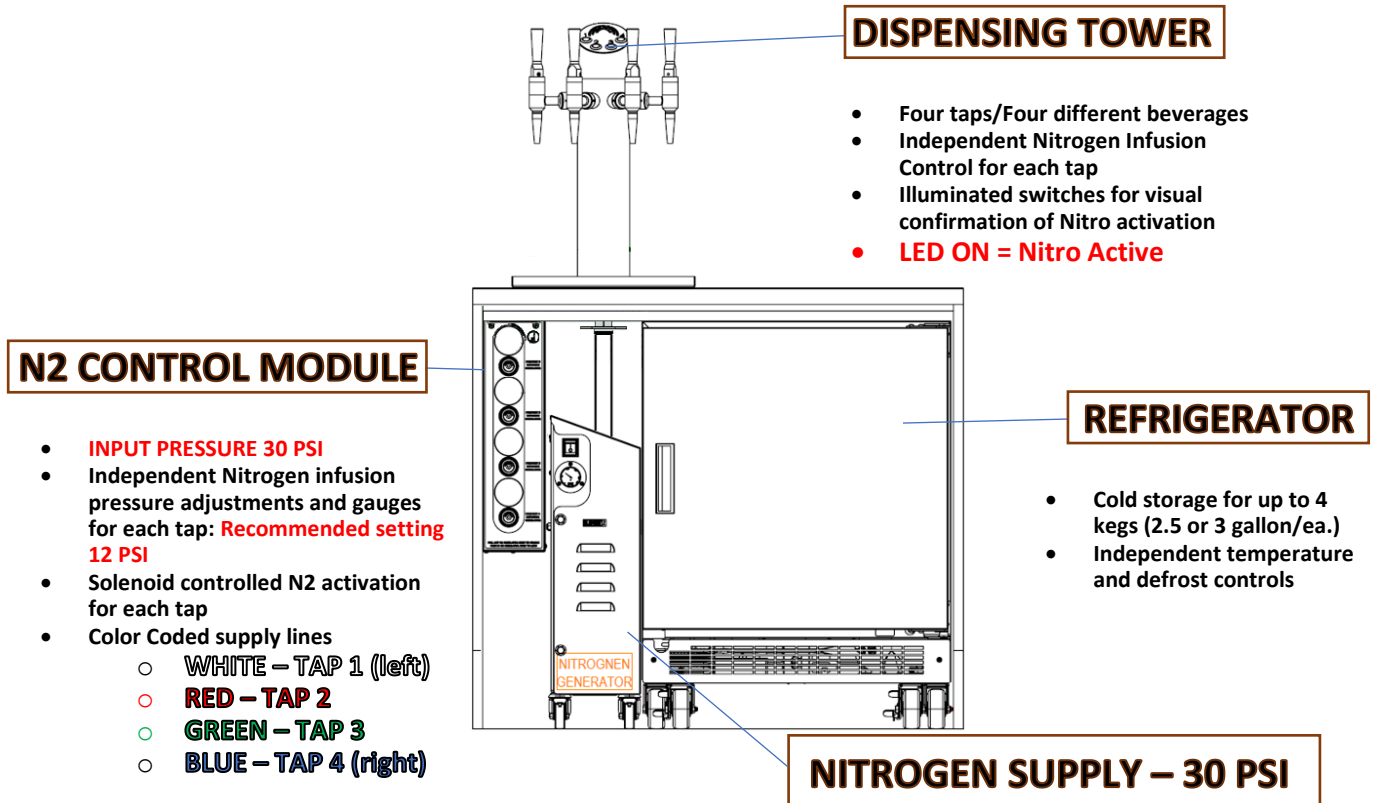
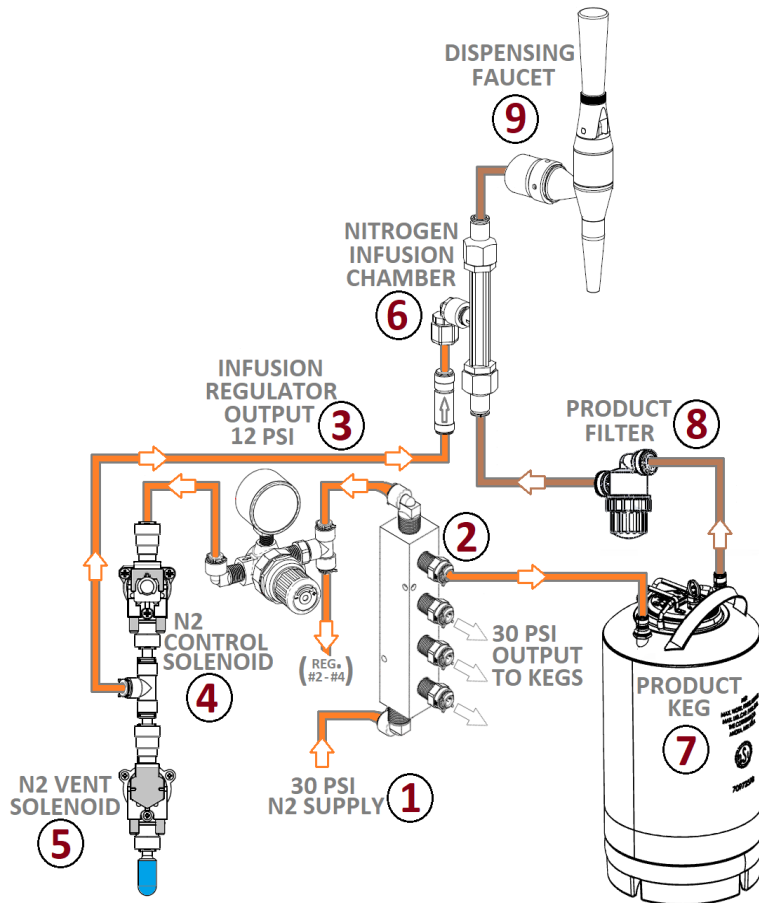

TABLE OF CONTENTS

- **PAGE 2 – SYSTEM OVERVIEW**
- **PAGE 3 – COMPONENT OVERVIEW**
- **PAGES 4-5 – OPERATIONAL OVERVIEW**
- **PAGE 6 – NITRO BEVERAGE CALIBRATION**
- **PAGE 7 – NITRO TROUBLESHOOTING GUIDE**
- **PAGE 8 – CONTROL SYSTEM WIRING DIAGRAM**
- **PAGE 9 – NITRO COMPONENT REPLACEMENT GUIDE**
- **PAGE 10 – REFRIGERATOR OPERATIONS**
- **PAGE 11 – REFRIGERATOR PROGRAMMING/ERROR CODES**
- **PAGE 12 – REFRIGERATOR TROUBLESHOOTING GUIDE**
- **PAGES 13-15 – REFRIGERATOR INVERTER DIAGNOSTICS/REMOVAL AND COMPRESSOR DIAGNOSTICS**
- **PAGES 16-21 – REFRIGERATOR UI BOARD/HARNESS REPLACEMENT INSTRUCTIONS**
- **PAGE 22 – QUICK REFERENCE PARTS GUIDE**
- **PAGES 23-25 – CLEANING INSTRUCTIONS**

COMPONENT OVERVIEW



1. 30 PSI N2 SUPPLY INPUT

LOCATION: REAR PANEL OF N2 CONTROL MODULE.

N2 supplied via a Nitrogen generator or compressed gas cylinder. Adjustments to this pressure can be made via a regulator at the output of either nitrogen source. Supply pressure dictates the amount of pressure displacing liquid from the product keg.

Factory recommended setting: 30 PSI (50PSI MAX)

2. NITROGEN DISTRIBUTION BLOCK

LOCATION: INSIDE N2 CONTROL MODULE

Distributes incoming N2 Pressure to 4 separate kegs in the refrigerator. These pressures are not independently adjustable.

3. INFUSION REGULATORS (X4)

LOCATION: FRONT OF N2 CONTROL MODULE

Regulates N2 Pressure to each tap for proper infusion with liquid product within the N2 Infusion Chamber (6). Easily adjusted at the front of N2 Control Module. Increasing this pressure will add more froth to final product.

Factory recommended setting: 12 PSI.

4. N2 CONTROL SOLENOID (X4 -Normally Open/24VDC/88-90Ω)

LOCATION: INSIDE N2 CONTROL MODULE.

Activated by the Nitrogen Select buttons at the top of the Dispensing Tower, the N2 Control Solenoids determine the presence of N2 pressure at the Infusion Chamber. These valves are NORMALLY OPEN. An illuminated N2 Select Button DOES NOT apply 24VDC to the valve, allowing a nitrogen infused beverage to be dispensed.

5. N2 VENT SOLENOID (X4 -Normally Closed/24VDC/88-90Ω)

LOCATION: INSIDE N2 CONTROL MODULE.

When N2 supply pressure to the Infusion Chamber is stopped by the N2 Control Solenoid, any static N2 pressure in the supply line is vented through the N2 Vent Solenoid for 2 seconds. This is controlled via Timer Relays inside the N2 Control Module.

6. NITROGEN INFUSION CHAMBER (X4)

LOCATION: INSIDE DISPENSING TOWER

Nitrogen pressure controlled by the N2 Control Solenoid is blended with liquid product from the kegs to produce a nitrogen infused beverage.

7. PRODUCT KEG (UP TO 4)

LOCATION: INSIDE REFRIGERATOR

Rated at 2.5 or 3 gallons, these product kegs store beverage products prepared by the customer. Liquid is forced from the kegs by incoming Nitrogen pressure at 30 PSI. *NOTE* Storing product kegs under Nitrogen pressure for more than 48 hours will saturate the product with Nitrogen gas and cause frothy beverages to be dispensed at all times.

8. PRODUCT FILTER (X4)

LOCATION: INSIDE REFRIGERATOR

A removable and cleanable particulate filter that prevents clogging of smaller orifices within the dispensing tower

9. DISPENSING FAUCET (X4)

LOCATION: TOP OF DISPENSING TOWER

A manually operated lever utilized for dispensing of product. It is important that the lever is pulled to a completely horizontal position for proper dispensing. The faucet is serviceable with available internal components.

OPERATIONAL OVERVIEW

NITROGEN CONTROL BOX/TOWER OPERATIONS

ILLUMINATED BUTTON – NITRO ACTIVATED

Nitrogen Control Solenoid status: OPEN – NO VOLTAGE PRESENT
 Nitrogen Vent Solenoid status: CLOSED – NO VOLTAGE PRESENT
 Nitrogen pressure from the Infusion Regulator enters the Normally Open N2 Control solenoid valve and allowed to pass through. The N2 Vent Solenoid is closed, channeling the Nitrogen Gas to the Infusion Chamber.

NON-ILLUMINATED BUTTON – NITRO DEACTIVATED

Nitrogen Control Solenoid status: CLOSED – 24VDC PRESENT
 Nitrogen Vent Solenoid status: TEMPORARILY OPEN – 24VDC PRESENT (2 seconds only)

When a Tower Button is switched from ILLUMINATED to NON-ILLUMINATED, the Nitrogen Control solenoid will activate and close the nitrogen supply to the Infusion Chamber. The Timer relay in the Control Box will send 24 VDC to the Vent Solenoid for 2 seconds to purge static nitrogen pressure from the supply line to the infusion chamber. After 2 seconds the Vent Solenoid will close.

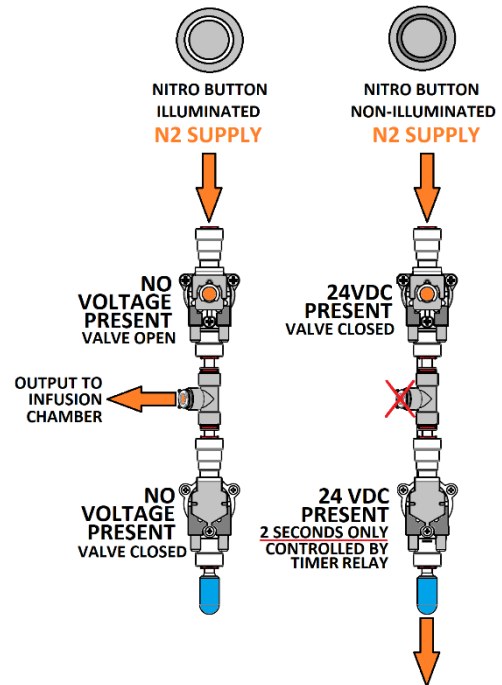

TIMER RELAYS

The Timer Relays located inside the Nitrogen Control Module provide a 2 second limit to voltage applied to the Vent solenoid. When a Tower Button is switched from ILLUMINATED to NON-ILLUMINATED, a constant supply of 24VDC is sent to the input of the Timer Relay. The resistor placed on the Timer Relay load circuit will allow only 2 seconds of power to be applied to the valve.

TO TROUBLESHOOT: Verify the corresponding Tower button is NON-ILLUMINATED and measure the '+' terminal (YELLOW WIRE) on the Timer Relay for 24VDC. If voltage is present, measure voltage at the 'LOAD' terminal (BROWN WIRE) while cycling the Tower Button between ILLUMINATED TO NON-ILLUMINATED. Verify the presence of 24VDC for 2 seconds only when the Tower Button switches to NON-ILLUMINATED.

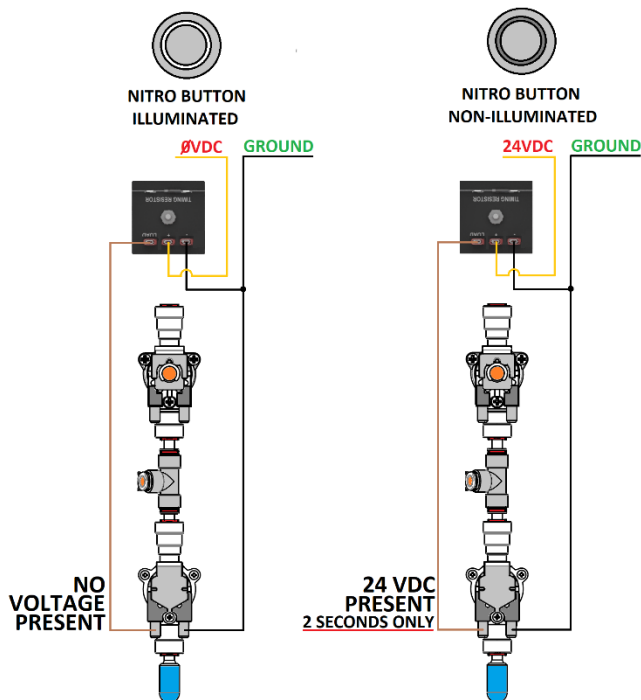

OPERATIONAL OVERVIEW cont.

NITROGEN FLOW AND COFFEE INTERACTION

- A. Incoming N2 pressure (30 PSI) from the Nitrogen Generator (or Gas Cylinder) is directed into each product keg, displacing the liquid. Product is channeled out of the keg and through an in-line filter into the base of the infusion chamber located inside the tower assembly.
- B. Nitrogen flow into the infusion chamber is controlled by the N2 Control Solenoid as previously discussed. 12 PSI of Nitrogen, set via the Infusion Regulators on the front of the N2 Control Module, is directed into the flow of liquid passing through the midsection of the infusion chamber and absorbed into the liquid.
- C. The Nitrogen infused liquid will be pushed through the system by 30 PSI of N2 Supply pressure.
- D. When the tap is opened, Nitrogen infused liquid will flow past the diaphragm and through the Diffusion Disk located in the nozzle. The Diffusion Disk is critical to the 'Cascading' process once the beverage has been dispensed into the cup.

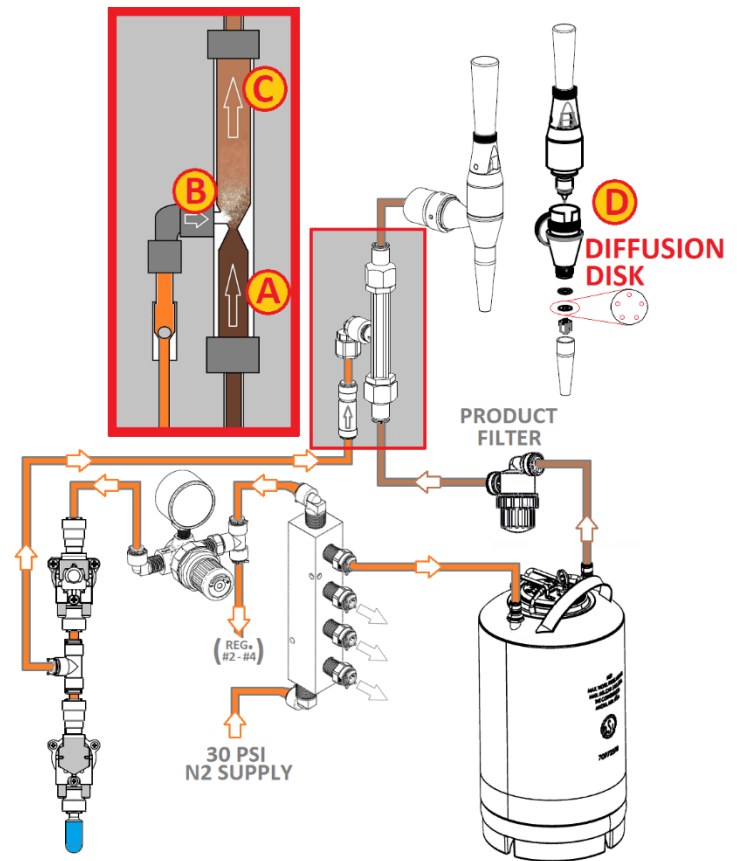

TROUBLESHOOTING TIP

UNWANTED NITROGEN INFUSION:

If Nitrogen gas is present on beverages designated as Non-nitro (non-illuminated button), the volume of unwanted nitrogen will help in determining the nature of the issue. Verify that operating pressures at the Primary N2 Regulator (30psi) and Infusion Regulators (12psi) are within specification. Slight modifications to the Infusion Regulator pressures can mitigate unwanted N2 infusion when switching from Nitro to Non-nitro beverages. If unwanted N2 remains, investigate the items to the right based on the levels of unwanted nitrogen.

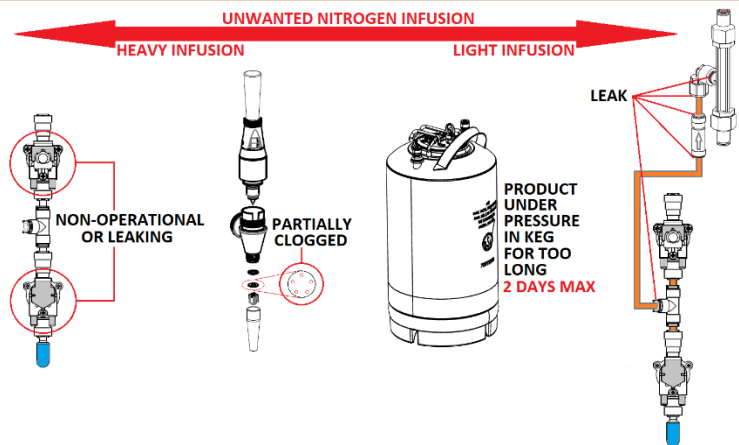

NITRO BEVERAGE CALIBRATION

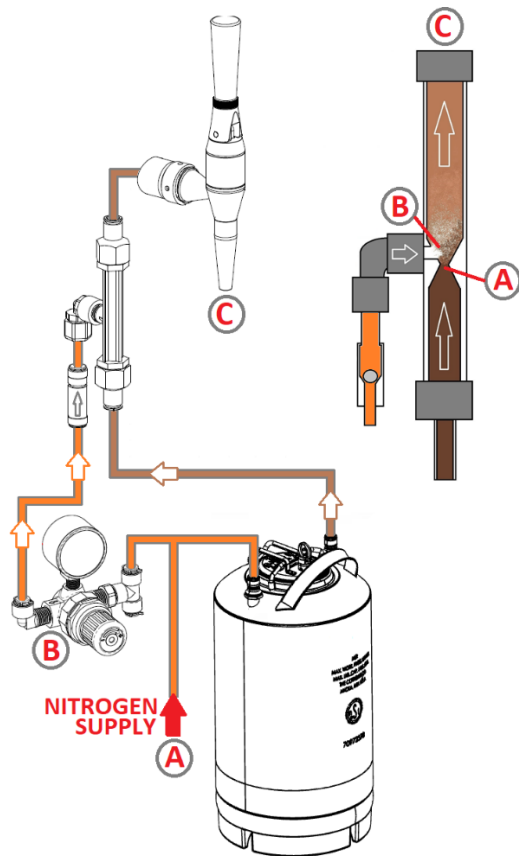

DIAGRAM KEY

- A:** OUTPUT PRESSURE FROM NITROGEN SOURCE (N2 GENERATOR OR COMPRESSED GAS CYLINDER)
- B:** NITROGEN INFUSION PRESSURE
- C:** PRODUCT OUTPUT

**Please note that the Nitrogen Control components have been removed from the diagram for simplification. The calibration guidelines below assume that the system is clean and all components are working properly.*

CAUSE AND EFFECT

A: Nitrogen Supply Pressure (30PSI RECOMMENDED)

This setting should be considered a baseline as it affects all 4 product kegs. Because this pressure dictates the amount of pressure that will displace, or 'push', product from the keg, higher pressure settings will accelerate the flow of product through the infusion chamber, creating higher vacuum pressures and increased agitation. Higher pressures will INCREASE the level of N2 froth in the beverage and contribute to N2 'carryover' when switching from Nitro infused beverages to non-nitro beverages.

B: Infusion Pressure

These settings are independently controlled for each tap and should be the primary adjustment utilized for determining the level of N2 'froth' for finished products. Once the Nitrogen supply pressure (A) has been set, adjust the Infusion pressure regulators until the optimal level of froth has been achieved for each product tap. Increasing the Infusion Pressure will INCREASE the level of froth in the beverage. 12 PSI is the factory setting, but slight adjustments may be necessary to account for conditions specific to the site such as altitude or type of product being dispensed. Products that do not contain oil, such as tea or lemonade, may need HIGHER infusion pressures to achieve optimal results.

C: Product output

The product output is used to determine needed pressure adjustments. It is very important that the Tap Handles are pulled all the way downward to a horizontal position when dispensing beverages. Failure to do so will impact the level of N2 infusion in the finished product.

NITROGEN CARRYOVER: After a Nitrogen infused beverage is dispensed, a small amount of infused product becomes trapped between the infusion chamber and the tap. When the tap is switched to pour a non-nitro beverage, the trace amounts of Nitrogen infused liquid in the product line are incorporated into the non-nitro beverage. This phenomenon is most noticeable in coffee-based beverages due to its dark coloring. To mitigate this, lower the infusion pressure (B) for the specific tap until a balance is reached between having acceptable levels of nitrogen present for infused beverages with a minimum amount of N2 carryover when switched to non-nitro beverages.

NITRO SYSTEM TROUBLESHOOTING GUIDE

| SYMPTOM | POSSIBLE CAUSE |
|---|--|
| NO PRODUCT POUR – ALL FAUCETS | <ul style="list-style-type: none"> • No Nitrogen pressure from Nitrogen Generator or Compressed Gas Cylinder |
| NO PRODUCT POUR – SINGLE FAUCET | <ul style="list-style-type: none"> • No product in keg (Opening faucet will dispense compressed gas only) • Improperly connected or faulty GAS/LIQUID connectors at product keg • In-line product filter completely clogged • Diffusion Disk completely clogged • Clogged pick-up tube in keg |
| NITRO POUR ONLY – ALL FAUCETS | <ul style="list-style-type: none"> • Faulty Power Supply or poor Power Supply connection at N2 Control Module • Primary Regulator set too high • All Product Kegs have been connected to N2 pressure for more than 48 hours |
| NITRO POUR ONLY – SINGLE FAUCET | <ul style="list-style-type: none"> • Faulty N2 Control Solenoid or bad wiring connection • Partially clogged Diffusion disk in Nozzle • N2 infused product in keg • Leak in N2 supply tubing to tower • Leaking N2 Vent Solenoid • Faulty Nitro Select Button at Tower • Product in keg is very low or has been exposed to N2 pressure for more than 48 hours |
| NON-NITRO POUR ONLY – SINGLE FAUCET | <ul style="list-style-type: none"> • Faulty Nitro Select Button at Tower • Faulty Infusion Regulator • Physical blockage of N2 Supply line • N2 ball valve closed • Missing restrictor disk in Nozzle |
| NITRO CARRYOVER WHEN SWITCHING FROM NITRO POUR TO NON-NITRO POUR | <ul style="list-style-type: none"> • Infusion Regulator set too high • Primary Regulator set too high • Faulty N2 Vent Solenoid or bad wiring connection • Faulty Timer Relay • Product in keg is very low or has been exposed to N2 pressure for more than 48 hours |

CONTROL BOX WIRING DIAGRAM

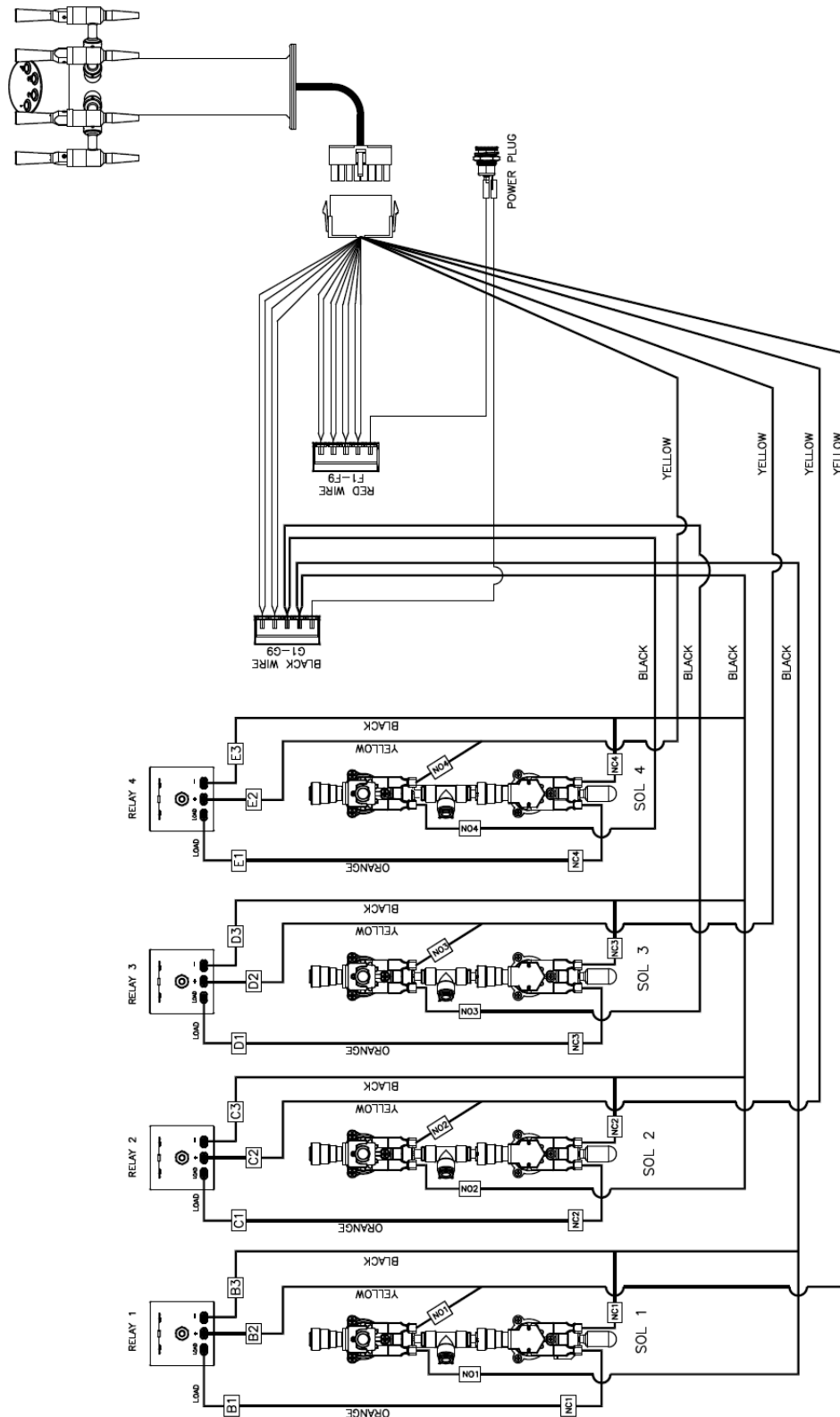

NITRO COMPONENT REMOVAL/DISASSEMBLY GUIDE

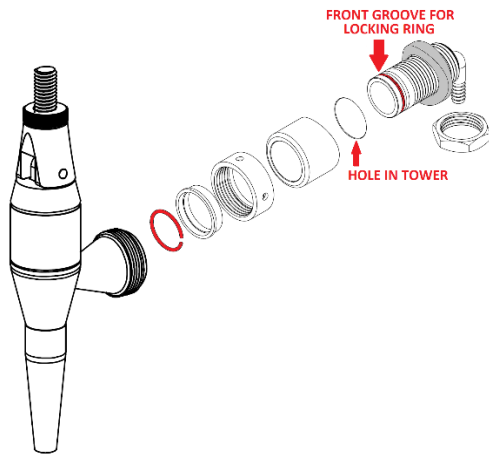

FAUCET SHANK DISASSEMBLY

- Disconnect BLACK/LIQUID Ball Lock Connector from Product Tank.
- Turn off N2 supply valve at base of Tower
- Open faucet to relieve pressure from line
- Remove Faucet by rotating Faucet Collar clockwise with faucet wrench
- Remove Tower cap and rest it on a Faucet handle that is not being removed
- Remove Locknut at rear of Shank
- Push shank forward far enough to remove locking collar at front of Shank
- Slide Shank hardware off front of shank

FAUCET DISASSEMBLY

- Disconnect BLACK/LIQUID Ball Lock Connector from Product Tank.
- Turn off N2 supply valve at base of Tower
- Open faucet to relieve pressure from line
- Unscrew Faucet lever and nozzle as indicated
- Replace Diaphragm, O-ring and Diffusion Disk
- Reassemble in reverse order, noting the location of the alignment notch. The Faucet lever will only face one direction, with the handle tilting forward

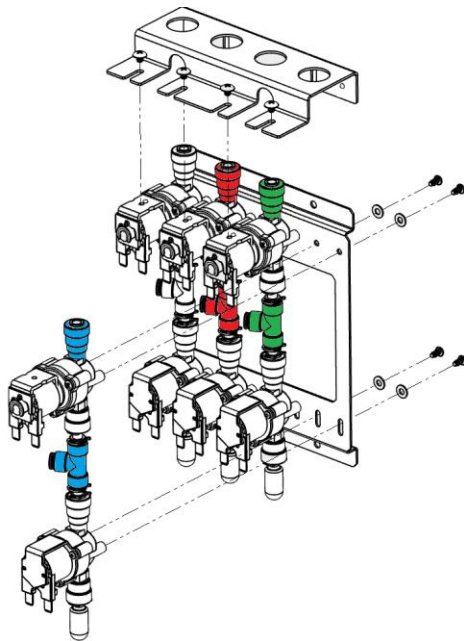
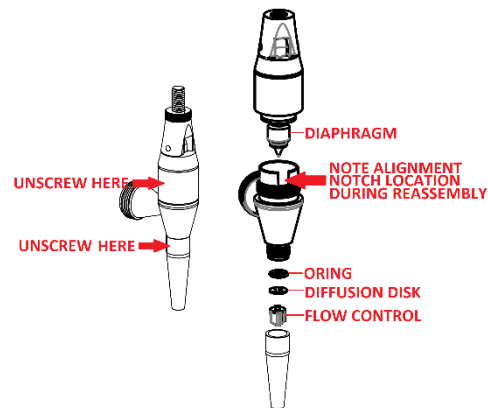

VALVE REMOVAL/REPLACEMENT

- Unplug Power Supply from rear of Control Box
- Turn off Nitrogen supply to Control Box
- Remove Control Box cover
- Remove the 8 red locking clips at the N2 Input/outputs. Four clips at top of valve assemblies (input) and 4 clips at the tee fittings between the two valves (output)
- Remove colored N2 supply lines at top of valve assemblies and at output tees
- Remove wiring from all solenoids. Wires are labelled, but make note of locations
- Remove heat-sink screws from top solenoids
- Remove 4 screws from solenoid mounting plate and remove mounting plate from Control Box
- Remove 4 screws from rear of Mounting Plate securing Valve Assembly
- Replace defective Valve as needed and reassemble in reverse order

REFRIGERATOR OPERATIONS

Factory Temperature Setting: **38°F**

PRIMARY COOLING COMPONENTS

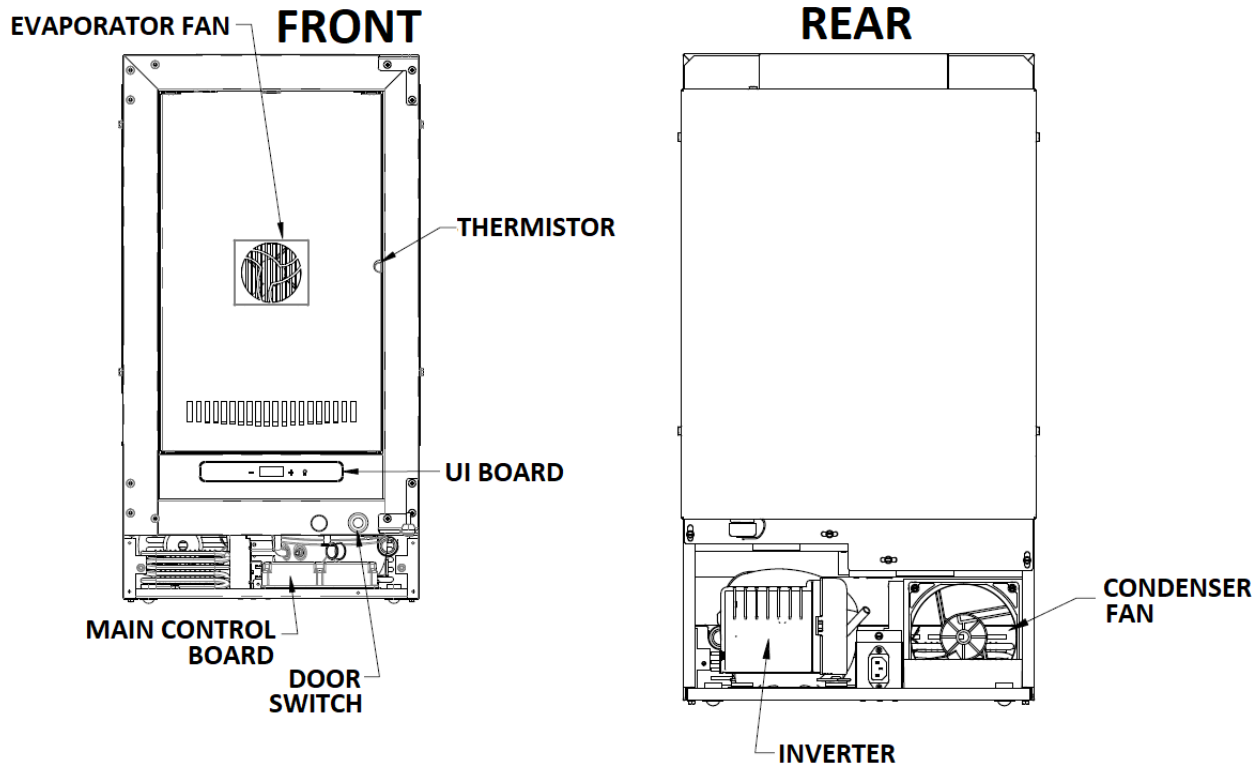

| DESCRIPTION | FUNCTION | |
|--|---|----------------------------|
| EVAPORATOR FAN | Provides air circulation for refrigerator interior. *NOTE* will not operate when door is open or if the compressor is not actively cooling. Engage door switch to test fan. | |
| THERMISTOR | Measures air temperature of refrigerator interior. Monitored through UI Board. | |
| UI BOARD | User Interface for refrigerator operations. Will display temperature status and allow for temperature adjustment as well as defrost operations. | |
| MAIN CONTROL BOARD | Primary controller of cooling components including compressor and fan operations. | |
| DOOR SWITCH | Provides status of door (OPEN/CLOSED) for Main Control Board. | |
| INVERTER | Internal capacitors for Compressor operations. Allows for 120V or 208/240V operations | |
| CONDENSER FAN | Dissipates heat from condenser coil | |
| REFRIGERATOR SELF DIAGNOSTIC TEST | | |
| Within the first 10 minutes of plugging the unit in, press and hold the "+" icon until 'Ct' is displayed and then press and hold the 'LIGHTBULB' icon for 3 seconds. All sections of the 7-segment LED on the UI Board should illuminate for 3 seconds. The diagnostic test will take a few minutes to complete. | | |
| ERROR CODE | DESCRIPTION | ACTION |
| 'E1' | NON-FUNCTIONING THERMISTOR | REPLACE THERMISTOR |
| 'EP' | EPROM FAILURE | REPLACE MAIN CONTROL BOARD |
| 'BR' | MAIN BOARD FAILURE | REPLACE MAIN CONTROL BOARD |

REFRIGERATOR PROGRAMMING/ERROR CODES

REFRIGERATOR PROGRAMMING



PRESS AND HOLD
5 SECONDS

'CURRENT TEMP'



PRESS TO DISPLAY CURRENT
THERMISTOR READING

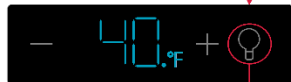

PRESS AND RELEASE

'DEFROST TIMER'



PRESS TO DISPLAY
DEFROST DURATION



ADJUST IF NECESSARY

'COMPRESSOR RUN TIME'



PRESS TO DISPLAY
DEFROST INTERVAL



ADJUST IF NECESSARY

'TEMPERATURE OFFSET'



ADJUST IF NECESSARY

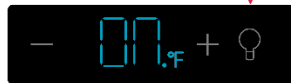

TURN REFRIGERATOR 'OFF' OR 'ON'



PRESS AND HOLD FOR 5 SECONDS



PRESS AND HOLD FOR 5 SECONDS



DISPLAY AND CHANGE OPERATING TEMPERATURE



PRESS TO DISPLAY CURRENT
TEMP SETTING



LOWER TEMP RAISE TEMP
WAIT 5 SECONDS

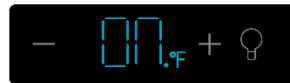

COOLING COMMAND TO COMPRESSOR



INDICATES SYSTEM IS ACTIVELY COOLING

REFRIGERATOR ERROR CODES



COMMUNICATION ERROR
BETWEEN UI BOARD AND
MAIN CONTROL BOARD



THERMISTOR
COMMUNICATION
ERROR



MAIN BOARD
EPROM FAILURE



MAIN BOARD
EPROM FAILURE

REFRIGERATOR PROGRAMMING KEY



CURRENT TEMPERATURE
MEASUREMENT FROM
THERMISTOR



NUMBER OF MINUTES SYSTEM
WILL REMAIN IN DEFROST CYCLE







THE NUMBER OF CUMULATIVE
COMPRESSOR RUN-TIME HOURS
BEFORE DEFROST CYCLE ENGAGES



TEMPERATURE OFFSET BETWEEN
ACTUAL READING OF THERMISTOR
AND TEMPERATURE DISPLAYED

REFRIGERATOR INVERTER DIAGNOSTICS & REMOVAL

| | |
|---|--|
| <p>**DISCONNECT UNIT FROM POWER**</p> <p>REMOVE SCREWS SECURING THE LOWER PANEL FROM REAR OF UNIT.</p> |  |
| <p>REMOVE SCREW ON RIGHT SIDE OF INVERTER, THEN PUSH THE LOCKING TAB TOWARD FRONT OF COOLER TO RELEASE INVERTER COVER.</p> |  |
| <p>REMOVE SCREW FROM WIRE STRAIN RELIEF BLOCK.</p> |  |
| <p>USING NEEDLE NOSED PLIERS, REMOVE THE BLACK (POWER) AND WHITE (NEUTRAL) WIRES FROM THE INVERTER.</p> |  |
| <p>INSERT TEST A LEAD FROM A MULTI METER INTO EACH OF THE WIRES. RECONNECT SYSTEM TO POWER AND VERIFY 120VAC IS PRESENT. IF NO VOLTAGE PRESENT, THEN THERE IS A CONTINUITY ISSUE OR NO SOURCE VOLTAGE.</p> |  |

****DISCONNECT UNIT FROM POWER****

UNPLUG BLUE WIRE FROM INVERTER BY PRESSING TAB TO RELEASE IT FROM SOCKET.

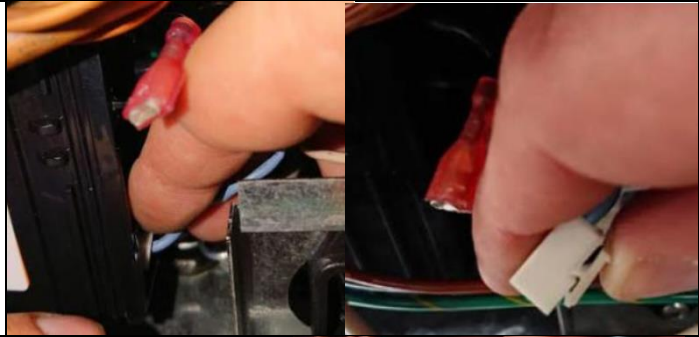

RECONNECT UNIT TO POWER AND VERIFY THAT THE COMPRESSOR OPERATION INDICATOR IS LIT ON THE UI BOARD. IF LIT, MEASURE VOLTAGE FROM BLUE WIRE TO CHASSIS GROUND. IF NO VOLTAGE IS PRESENT, REPLACE THE MAIN CONTROL BOARD AT FRONT OF UNIT. IF VOLTAGE IS PRESENT, PROCEED TO NEXT STEP.

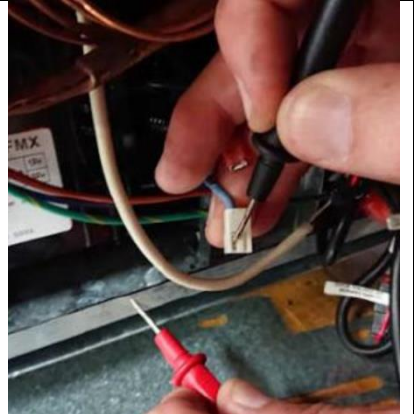

****DISCONNECT UNIT FROM POWER****

DISCONNECT GROUND WIRE AND REMOVE THE TWO SCREWS AS INDICATED. PULL THE BASE OF THE INVERTER AWAY FROM THE COMPRESSOR, ROTATING IT UPWARDS FOR REMOVAL.



DISCONNECT GROUND WIRE AND COMPRESSOR POWER CONNECTION. UTILIZE A ROCKING MOTION TO REMOVE COMPRESSOR POWER CONNECTOR.



RECONNECT WIRING TO THE INVERTER AS SHOWN. **RECONNECT UNIT TO POWER.**



MEASURE VOLTAGE AT EACH OF THE THREE OUTPUTS ON THE COMPRESSOR CONNECTOR. ALL THREE SHOULD MEASURE APPROXIMATELY 120VAC. INSUFFICIENT VOLTAGE AT ANY OF THESE OUTPUTS INDICATES THE INVERTER NEEDS REPLACEMENT. PROPER VOLTAGE INDICATES THE COMPRESSOR HAS FAILED.

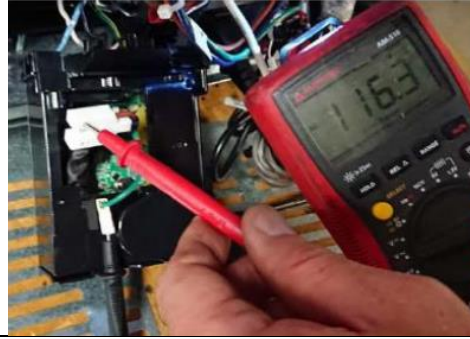

INSTALL REPLACEMENT INVERTER BY REVERSING THE REMOVAL STEPS OUTLINED ABOVE. TEST COMPRESSOR OPERATIONS ONCE REPLACEMENT IS COMPLETE.

COMPRESSOR OPERATIONS/DIAGNOSTIC GUIDE

| System Condition | Suction Pressure | Suction Line | Compressor Discharge | Condenser | Capillary Tube | Evaporator | Wattage |
|-----------------------------|-----------------------------------|---------------------------------|-------------------------|---|-----------------------------------|--|--------------------|
| Normal | Normal | Slightly below room temperature | Very hot | Very hot | Warm | Cold | Normal |
| Overcharge | Higher than normal | Very cold may frost heavily | Slightly warm to hot | Hot to warm | Cool | Cold | Higher than normal |
| Undercharge | Lower than normal | Warm-near room temperature | Hot | Warm | Warm | Extremely cold near inlet - Outlet below room temperature | Lower than normal |
| Partial Restriction | Somewhat lower than normal vacuum | Warm-near room temperature | Very hot | Top passes warm - Lower passes cool (near room temperature) due to liquid | Room temperature (cool) or colder | Extremely cold near inlet - Outlet below room temperature backing up | Lower than normal |
| Complete Restriction | In deep vacuum | Room temperature (cool) | Room temperature (cool) | Room temperature (cool) | Room temperature (cool) | No refrigeration | Lower than normal |
| No Gas | 0 PSIG to 25" | Room temperature (cool) | Cool to hot | Room temperature (cool) | Room temperature (cool) | No refrigeration | Lower than normal |

REFRIGERATOR UI BOARD/HARNESS REPLACEMENT

| | |
|---|--|
| <p>**DISCONNECT UNIT FROM POWER**</p> <p>PEEL ADHESIVE OVERLAY FROM UI MOUNTING BRACKET.</p> |  |
| <p>REMOVE BOTH UI MOUNTING BRACKET SCREWS.</p> |  |
| <p>DISCONNECT WIRING HARNESS FROM UI BOARD AND DISCARD BOARD/BACKET ASSEMBLY.</p> |  |
| <p>MAKING SURE THAT THE MOUNTING HOLES AND DISPLAY ARE PROPERLY ALIGNED, SNAP THE NEW UI BOARD INTO NEW MOUNTING BRACKET.</p> |  |
| <p>PEEL AWAY THE ADHESIVE SEAL COVER TO EXPOSE THE FOAM INSULATION GASKET. TAKE CARE TO NOT TOUCH THE GASKET ONCE THE COVER HAS BEEN REMOVED.</p> |  |

THOROUGHLY CLEAN THE STAINLESS STEEL MOUNTING SURFACE FOR THE OF THE UI BRACKET WITH ALCOHOL IF POSSIBLE. RECONNECT THE UI BOARD TO THE WIRING HARNESS. ENSURE THE MOUNTING HOLES ARE ALIGNED WITH STUDS AND ADHERE THE MOUNTING BRACKET TO THE COOLER.



SCREW THE MOUNTING BRACKET IN PLACE.

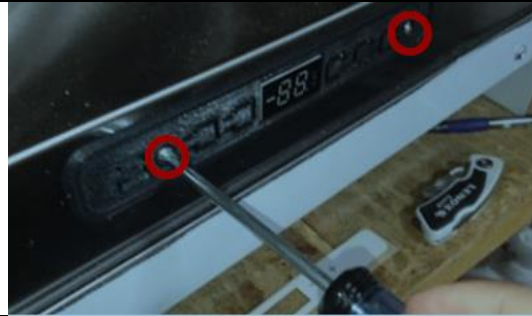

PEEL ADHESIVE BACKER FROM NEW OVERLAY AND APPLY IT TO THE MOUNTING BRACKET.



PROCESS COMPLETE

UI HARNESS REPLACEMENT PROCEDURE

****DISCONNECT UNIT FROM POWER****

PEEL ADHESIVE OVERLAY FROM UI MOUNTING BRACKET.

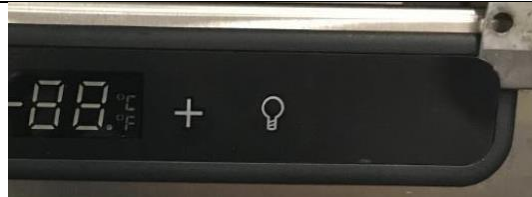

REMOVE BOTH UI MOUNTING BRACKET SCREWS.



DISCONNECT WIRING HARNESS FROM UI BOARD AND DISCARD OLD BRACKET ONLY. RETAIN UI BOARD FOR REINSTALLATION.



CUT THE DAMAGED WIRE CONNECTOR AS CLOSE TO THE UI CASING AS POSSIBLE. DISCARD DAMAGED CONNECTOR.



LAY THE COOLER ON ITS BACK BEING CAREFUL NOT TO OVER-EXTEND THE TUBING BUNDLE. ON THE BOTTOM SURFACE OF THE OVERHANG, PLACE A MARK 12" (CENTER) FROM THE EDGE OF THE COOLER AND 1" FROM THE FRONT FACE OF THE OVERHANG.



COVER THE LOWER VENT WITH A TOWEL OR PAPER TO PREVENT INTRODUCTION OF SHAVINGS INTO THE SYSTEM. USING A 5/8" DRILL BIT, DRILL THROUGH THE COOLER FRAME INTO THE UI CASING.



AFTER DEBURRING THE HOLE JUST DRILLED, RETURN COOLER TO STANDING POSITION. PLACE THE PROVIDED GROMMET ON TO END OF NEW UI CABLE AS SHOWN. APPLY TAPE TO END OF CONNECTOR TO PROTECT IT FOR NEXT STEP.



FEED THE TAPED END OF THE CONNECTOR THROUGH THE 5/8" HOLE AND UP INTO THE UI CASING. INSERT GROMMET INTO STAINLESS HOLE AND SEAT IT.



REMOVE TAPE FROM CONNECTOR AND SECURE TO UI BOARD. USE SILICONE SEALANT TO FILL THE GAPS OF THE 5/8" HOLE.



MAKING SURE THAT THE MOUNTING HOLES AND DISPLAY ARE PROPERLY ALIGNED, SNAP THE OLD UI BOARD INTO NEW MOUNTING BRACKET.



PEEL AWAY THE ADHESIVE SEAL COVER TO EXPOSE THE FOAM INSULATION GASKET. TAKE CARE TO NOT TOUCH THE GASKET ONCE THE COVER HAS BEEN REMOVED.



THOROUGHLY CLEAN THE STAINLESS STEEL MOUNTING SURFACE FOR THE OF THE UI BRACKET WITH ALCOHOL IF POSSIBLE. RECONNECT THE UI BOARD TO THE WIRING HARNESS. ENSURE THE MOUNTING HOLES ARE ALIGNED WITH STUDS AND ADHERE THE MOUNTING BRACKET TO THE COOLER.



SCREW THE MOUNTING BRACKET IN PLACE.



PEEL ADHESIVE BACKER FROM NEW OVERLAY AND APPLY IT TO THE MOUNTING BRACKET.

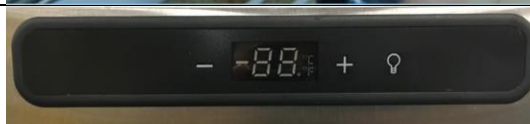

REMOVE BOTH SCREWS SECURING THE LOWER FRONT VENT. REMOVE VENT COVER AND SET ASIDE



REMOVE 5 SCREWS SECURING LOWER VENTILATION PANEL AT REAR OF COOLER. SET PANEL ASIDE.

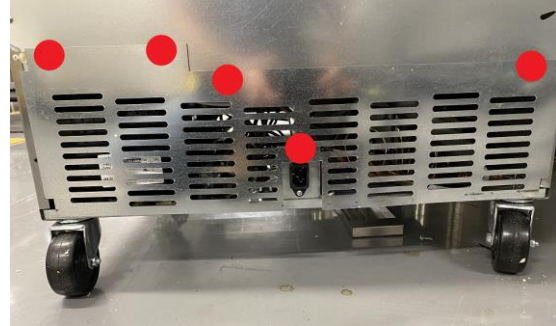

LOCATE WIRING BUNDLE INSIDE UNIT AND CUT CABLE TIE SECURING BUNDLE TOGETHER.



LOCATE WIRE HARNESS FOR 'DISPLAY BOARD' AND UNPLUG OLD CABLE FROM HARNESS. BUNDLE OLD CABLE WITH FASTENER AND TUCK INSIDE THE UNIT OUT OF THE WAY.



FEED NEW CABLE CONNECTOR THROUGH THE FRONT OF THE TOP MIDDLE VENT OF THE LOWER FRONT PANEL. FEED NEW CABLE THROUGH LOWER CHASSIS TO REAR OF UNIT.



PULL CABLE TO REAR OF UNIT UNTIL NO SLACK REMAINS AND MOUNT FRONT VENT.



PULL NEW CABLE THROUGH TO REAR OF UNIT AND CONNECT TO WIRING HARNESS. BUNDLE ALL HARNESSES BACK TOGETHER WITH A FASTENER AND TUCK BUNDLE BACK INSIDE UNIT.

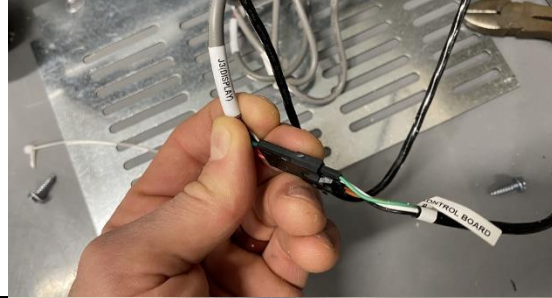



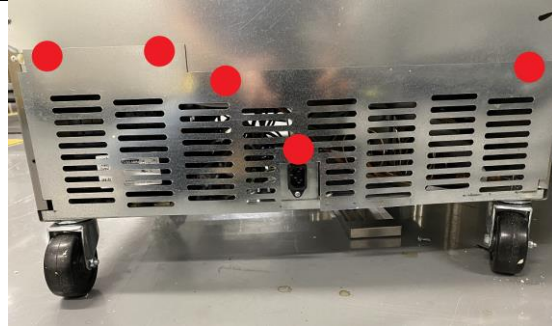









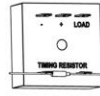

MOUNT BACK PANEL TO REAR OF UNIT AND TEST UI BOARD OPERATIONS.

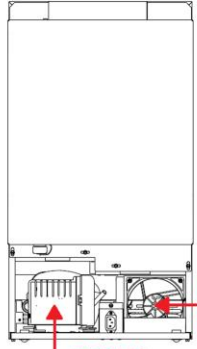

PROCESS COMPLETE

QUICK REFERENCE PARTS GUIDE

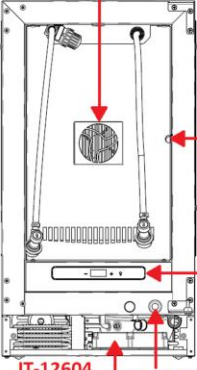
| TOWER | N2 CONTROL MODULE | REFRIGERATOR |
|--|---|--|
|  <p>FAUCET ASSY 1635-20Y24</p>  <p>FAUCET REPAIR KIT 1635-20L10</p>  <p>CHECK VALVE JT-14CVR</p>  <p>BUTTON SWITCH 1607-20D23</p> |  <p>TIMER RELAY TH-1011</p>  <p>0-30 PSI GAUGE 1618-20J15</p>  <p>INFUSION REGULATOR ASSY TH-10008</p>  <p>N2 CONTROL SOLENOID SLND-20D24-1</p>  <p>N2 VENT SOLENOID SLND-20D23</p> |  <p>JT-12606 CONDENSER FAN</p> <p>JT-12779 INVERTER</p>  <p>GAS BALL LOCK JT-4027110277</p>  <p>LIQUID BALL LOCK JT-4027110299</p>  <p>12.3MM HOSE CLAMP JT-16700009</p>  <p>1610-20L09 FILTER ELEMENT ONLY</p>  <p>JT-12609 POWER CORD</p>  <p>JT-12607 EVAP. FAN</p> <p>JT-12608 THERMISTOR</p> <p>JT-12621K UI BOARD KIT</p> <p>JT-UIHARNK UI HARNESS KIT (DOES NOT INCLUDE UI BOARD)</p> <p>JT-12604 MAIN BOARD</p> <p>JT-12781 DOOR SWITCH</p> |

| PART NUMBER | DESCRIPTION |
|---------------|---------------------------------------|
| 1607-20D23 | PUSHBUTTON 19MM, HIGH ROUND HEAD |
| 1618-20J15 | GAUGE PRESSURE, 1-1/2" DIAL, 0-30 PSI |
| 1635-20Y21 | FTG ELBOW, 3/8 NPT X 1/4 TUBE |
| 1635-20Y24 | FAUCET, NITRO COFFEE |
| AF-068 | FTG 1/4 TUBE X 1/4 NPTF |
| CD-FT-004 | FTG ELBOW 1/4 TUBE X 1/4 NPT |
| SLND-20D23 | R MINI -118, 1/4" JG, NC, 24VDC |
| SLND-20D24-1 | SLND-20D24 W/ 8-32 TAPPED HOLE |
| TH-10008 | REGULATOR ASSY |
| TH-10011 | RELAY / RESISTOR 100K 2W ,ASSY |
| 1610-20L09 | FILTER SCREEN, 100 MESH |
| 1635-20L10 | FAUCET REPAIR KIT, NITRO COFFEE |
| JT-4027110277 | BALL LOCK DISCONNECT, 1/4' BARB, GAS |

| PART NUMBER | DESCRIPTION |
|---------------|---|
| JT-4027110299 | BALL LOCK DISCONNECT, 1/4' BARB, LIQUID |
| TH-10002 | INFUSION GROUP REPLACEMENT KIT |
| TH-30001 | N2 GEN PRIMARY REGULATOR |
| JT-12621K | UI BOARD REPLACEMENT KIT |
| JT-UIHARNK | UI HARNESS REPLACEMENT KIT |
| JT-12607 | FAN-EVAPORATOR JOETAP NITRO |
| JT-12606 | CONDENSER FAN |
| JT-12608 | THERMISTOR |
| JT-12604 | MAIN BOARD JADE515-SSXXA |
| JT-12781 | SWITCH, DOOR |
| JT-12779 | INVERTER, 120V DROP-IN |
| JT-16700009 | CLAMP HOSE 15/32, 12.3 MM, SS |
| JT-14CVR | CHECK VALVE |

CLEANING INSTRUCTIONS

CLEANING SOLUTION:

Use a Sanitizing Solution capable of providing 100 PPM of available chlorine when properly mixed with warm (approximately 100°F / 38°C) potable water. Examples:

- 1) **STERA-SHEEN**® Green Label sanitizer & cleaner available from Purdy Products Company in 2-ounce packets (**requires no Rinse step**).
- 2) **KAY 5**® chlorinating sanitizer available from Kay Chemicals in 1-ounce packets (**requires a Rinse step**).
- 3) **Other Sanitizing Solutions** that provide 100 PPM of available chlorine when properly mixed with warm (approximately 100°F / 38°C) potable water. Follow all cleaning and rinse instructions for any line cleaner.

CLEANING SOLUTION PREPARATION:

- 1) **STERA-SHEEN**®: Mix one, 2-ounce packet of Stera-Sheen® sanitizer powder with 2 gallons / 7-1/2 liters of 100°F / 38°C potable water in a clean product tank.
- 2) **KAY 5**®: Mix One, 1-ounce packet of Kay 5® sanitizer powder with 2-1/2 gallons / 9-1/2 liters of 100°F / 38°C potable water in a clean product tank.
- 3) **Other Sanitizing Solutions**: In a clean Product tank, mix the recommended amount of sanitizing solution or powder (per instructions) with the required amount of 100°F / 38°C potable water to achieve a 100 PPM concentration of available Chlorine. If using a cleaner with no rinse step, a minimum of 2 gallons must be prepared at a time. If using a cleaner with a rinse step, a minimum of 2-1/2 gallons must be prepared.

Before starting the cleaning process, you **MUST** determine how many faucets you will need to clean. A Four Faucet System will require 64-ounces of cleaning solution for each line for a total of 2-gallons.

1. Gather your supplies.
2. Place a bucket under the faucets
3. **Wash Instructions:** 100 PPM available chlorine cleaning solutions listed above.
 1. Prepare cleaning solution (see CLEANING SOLUTION PREPARATION above) in a clean 2-1/2, 3- or 5-gallon product tank. Install and latch the tank lid, ensure the relief valve is closed.
 2. Confirm that all faucets are closed. Then, connect the Grey Connector to the "IN" tank connection and connect the Black Connector to the "OUT" tank connection from the first set of jumper lines, this will correspond to faucet number one.



WARNING

When using cleaning fluids or chemicals, rubber gloves and eye protection should be worn.

3. Working from left to right, place a bucket under the first faucet. Pull and hold the first faucet handle open until ½ gallon (64 ounces) of cleaning solution is dispensed. Close the first faucet.
 4. Disengage the LIQUID ball lock fitting from the sanitizer tank (leave the GAS ball lock connected) and connect the product line for the next tap to be flushed.
 5. Move the bucket to the next faucet and repeat the dispensing portion of this step until ½ gallon (64 ounces) of cleaning solution has been dispensed from every faucet. Repeat steps 4, 5 for as many sets of jumper lines or faucets you have. Discard all liquid.
 6. **IMPORTANT! - ALLOW THE CLEANING SOLUTION TO REMAIN IN THE SYSTEM FOR A MINIMUM OF 5 MINUTES**
 7. Disconnect your now empty cleaning cannister from the system. Depressurize the canister, remove the lid, and thoroughly rinse the interior of the vessel.
- 4. Rinse Instructions:**
1. Disconnect your now empty cleaning cannister from the system. Depressurize the canister, remove the lid, and thoroughly rinse the interior of the vessel.
 2. Refill the cannister with 2 Gallons of cool potable water.
 3. Working from left to right, place a bucket under the first faucet. Pull and hold the first faucet handle open until ½ gallon (64 ounces) of cleaning solution/water is dispensed. Close the first faucet. Move the bucket to the next faucet, hook up the next set of jumper lines and repeat the dispensing portion of this step until ½ gallon (64 ounces) of cleaning solution/water has been dispensed from every faucet.
 4. If no Pre-Prepared product is available currently, use the now empty product tank to blow the remaining liquid from the lines. Start with 4, move to 3, then 2, and finally 1.
 5. Turn off the gas supply. Turn off the valve at the top of the nitrogen tank or follow nitrogen generator's specific instructions for turning off gas flow.
 6. Open the furthest left faucet over a bucket to establish that pressure is removed from the system. Continue to the next faucet, moving from left to right until you have established that all faucets in the system have no remaining pressure.
 7. Close all faucets before moving to next step.
 8. Separate the two halves of the filter bowl, located on the liquid product lines inside the refrigerator. *This may be difficult to remove – use caution if utilizing tools that may damage the filter housing.
 9. Remove the mesh filter element from the housing and rinse filter element and filter bowl of any undissolved sanitizer by lightly brushing and rinsing under warm potable running water.
 10. Reassemble filter bowl. Re-insert the mesh filter element, and screw on the bottom half of the filter bowl.
 11. Repeat steps 8,9, and 10 for as many filter bowls as are present.
 12. Turn the gas supply back on.

WARNING

When using cleaning fluids or chemicals, rubber gloves and eye protection should be worn.

13. Remove and inspect all faucet tips. You should be checking for debris in the faucet tip and if any of the five holes in the restrictor disc are plugged.
14. Clean the faucet tips over a small cleaning bucket with sanitizer with a small brush. Do this to avoid any faucet tip parts from falling into a drain. Once the tips are cleaned, wipe them dry with a clean towel and set aside.
15. Use a general-purpose sanitizing cleaner and a clean towel, wipe down faucets, faucet handles, drain pan, tower, surrounding area and all jumper lines.
16. Reinstall the faucet tips.
17. Wash out the dump pan and grate under warm potable running water. Alternatively, clean and sanitize the dump pan and grate in a 3-compartment sink, Wash, Rinse, Sanitize. The use of a dish washing machine should be avoided, this method may cause the adhesive bumpers on the dump pan to become detached. Pat the dump pan dry and replace to its location at the tower.

WARNING

When using cleaning fluids or chemicals, rubber gloves and eye protection should be worn.

5. Hook-Up (If Product Is Pre-Prepared)

1. Connect all 4 product tanks to their corresponding locations.
2. Working from left to right, place a bucket under the first faucet. Pull and hold the first faucet handle open until only the desired product flows from the nose cone. Move the bucket to the next faucet and repeat the dispensing portion of this step until only the desired product flows from the nose cone. Discard all liquid.