

# INSTRUCTIONS FOR USE

## KT-ALP

**AUTOMATIC  
MEAT PRESS**

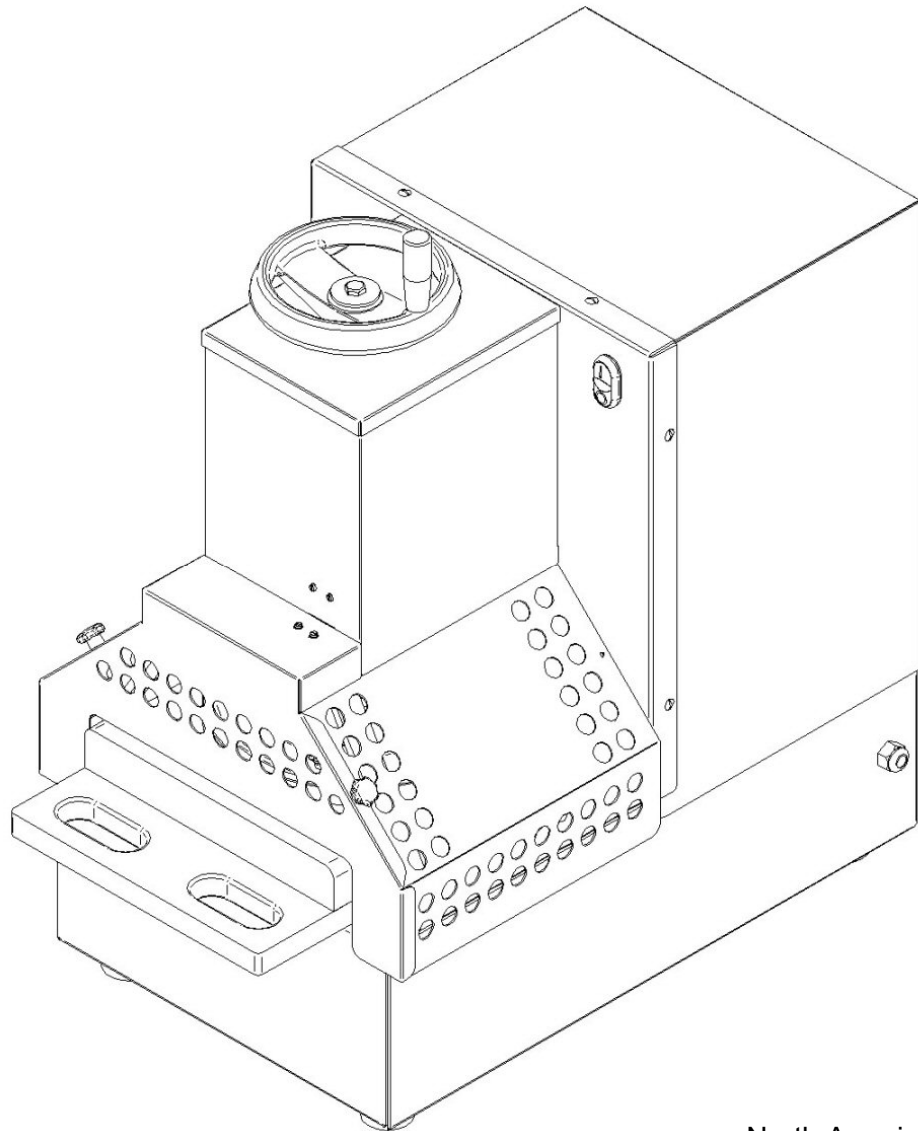

**Manufacturer:**

**KONETEOLLISUUS OY**

**Järvihaantie 5**

**01800 Klaukkala**

**Finland**

**Tel. +358 (0)9 878 9220**

**fax. + 358 (0)9 878 92233**

North American Distributor  
Jaccard Corporation  
70 Commerce Drive  
Rochester, NY 14623  
(866) 478-7373

Original instructions

## KT-ALP MEAT PRESS USER MANUAL

### *Warning!*

#### **Safety above all else**

The KT-ALP is a hydraulically operated meat press, which is designed to **thin and tenderise steaks**. Only use the machine for its intended purpose. If misused, the machine can **inflict damage to the user**.

- \* **DO NOT** use the machine unless you have read and completely understood this manual. Your attention is drawn in particular to the part which concerns safety.
- \* **DO NOT** use the machine unless all the covers are fixed firmly into place.
- \* **DO NOT** try to press articles other than meat with this machine.
- \* **DISCONNECT** the power source before cleaning.
- \* **REPORT** all faults immediately.
- \* **IF IN DOUBT, contact your local occupational safety inspector or ask the labour protection authorities for advice.**

## **LIST OF CONTENTS**

1. Introduction .....	3
1.1 Technical specifications.....	3
2. General description .....	3
3. Unpacking .....	4
4. Installation.....	5
4.1 Table .....	5
4.2 Direction of rotation .....	5
4.2.1 Switch diagram.....	5
4.3 Location .....	5
5. Operation .....	6
6. Cleaning .....	7
6.1 Stopping .....	7
6.2 Dismantling .....	7
6.3 Washing .....	8
6.4 Recommended detergents .....	8
7. Maintenance .....	8
7.1 Results from noise emission tests .....	8
ANNEX 1 Dimensional drawing .....	9
ANNEX 2 Spare parts list .....	10
ANNEX 3 Switch diagram .....	14

## **1. Introduction**

The KT-ALP is a hydraulically operated meat press which is designed for thinning and tenderising meat. Read this instruction manual carefully before using the machine and ensure also that all other users, service mechanics and cleaners have also read and thoroughly understood this manual, and also that they have familiarised themselves with the following:

1. use of the machine
2. dismantling, cleaning and reassembly of the machine.

All users must be given the correct training in the safe use of the meat press. The parts of this manual which deal with **SAFETY** must be read with particular attention.

### **1.1 Technical specifications**

Motor	1.5 kW, three-phase current
Weight	160 kg
Hydraulic pressure	100 bar
Oil tank capacity	14 litres
Oil	12 litres Iso VG32 hydraulic oil

## **2. General description**

The KT-ALP has been constructed on the basis of KT product development. The machine is simpler and faster in use than its predecessor, the KT-LP. The machine functions quietly and with minimum vibration. It is easy to dismantle for cleaning purposes. The machine is equipped with a safety switch in the front cover to ensure that it can only be started up safely when the cover is in place.

The start and stop switches (Diagram 1, No. 1 a, b) are located in the front panel. When the power is on, the machine commences the work cycle automatically once the plastic tray that holds the meat is pushed into the machine.

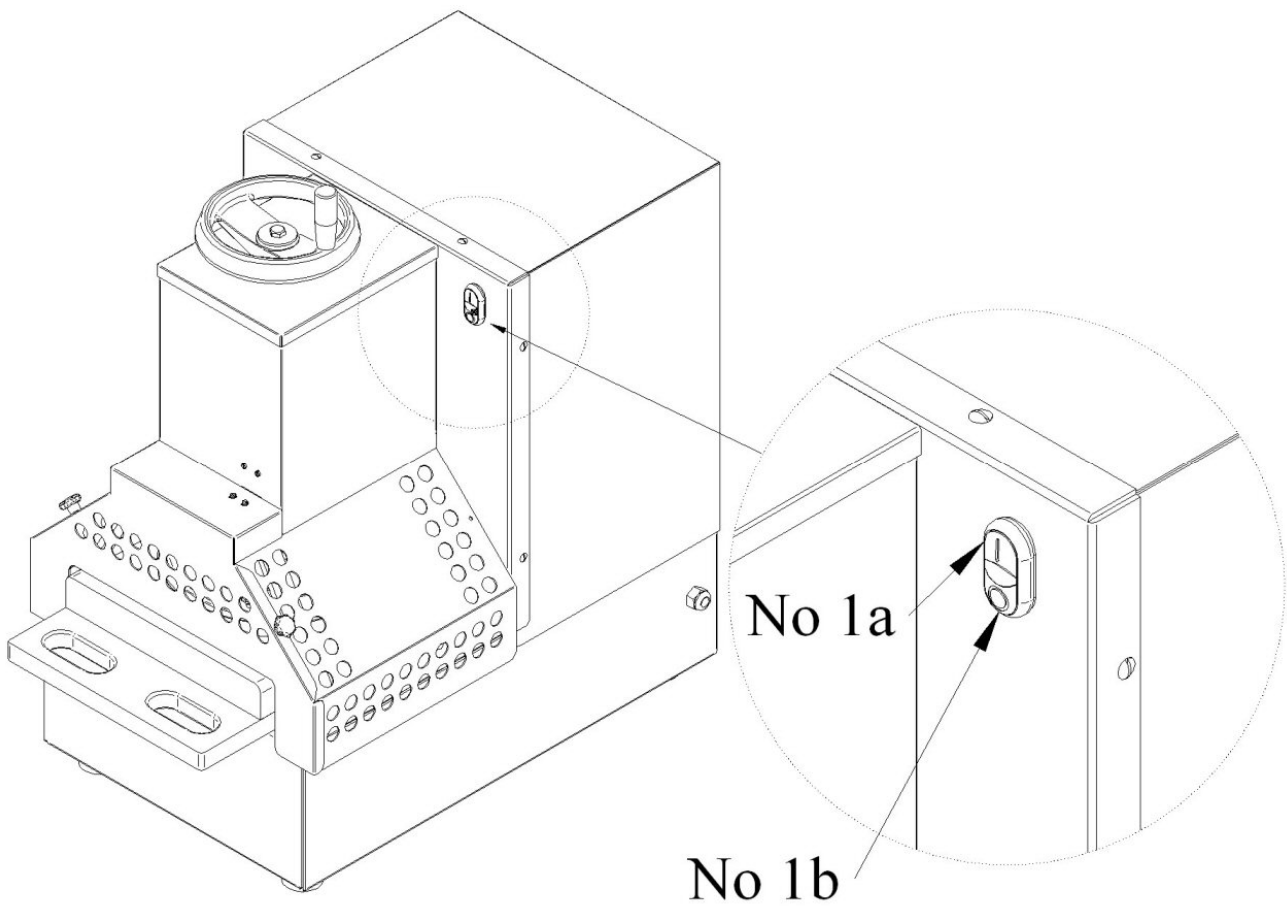

Diagram 1

### **3. Unpacking**

The meat press may be stored in the cold store. The machine must be cleaned thoroughly before use. If the meat press or the packaging has been damaged in transit, contact the retailer of the manufacturer.

The meat press may be lifted from the pallet and moved to its location using appropriate transport equipment. When moving the meat press, **ENSURE THAT IT IS NOT LIFTED TOO HIGH.**

## **4. Installation**

### *Please note:*

1. Ensure that the supply voltage corresponds with the voltage marked on the rating label.
2. The machine must be correctly earthed.
3. Only a competent electrician may connect the electricity supply to the machine and carry out electrical servicing work.
4. Ensure that the electrical supply has been properly disconnected before any electrical connections are made, or maintenance work is carried out.

### **4.1 Table**

The table must be sufficiently large to accommodate the meat press in its entirety. It must be of solid construction with a non-slip surface. The table must be of the correct height to allow for ergonomic working.

### **4.2 Direction of rotation**

Check the direction of rotation of the motor. If the machine starts up, but the work cycle does not commence as normal (the cylinder does not move), the direction of rotation is incorrect. Ask an authorised electrician to change the direction of rotation.

#### **4.2.1 Switch diagram**

The switch diagram for the meat press is to be found in Annex 3 to this manual.

### **4.3 Location**

The machine must be installed in a place where there is sufficient room to work around the machine and enough light to allow safe working. For the safety of the operator, the floor must have a non-slip surface.

## **5. Operation**

Before operation, ensure that the machine's **GUARDS ARE IN PLACE**. Never operate the machine without having first read the instruction manual. Make sure that the manual is available to everyone who operates the machine.

### ***Procedures:***

1. Switch on the power (Diagram 1, switch 1 a)
2. Place the plastic tray (Diagram 2, No. 2) between the work table guide rails (Diagram 2, No. 3).
3. Place the steak being pressed in the middle of the plastic tray.
4. Push the plastic tray inside the machine, against the back wall. The work cycle begins automatically.
5. When the press plate (cylinder) has lifted up, pull out the plastic tray.
6. If the steak has not been pressed to a sufficient degree, adjust the cylinder downwards by turning the handwheel (Diagram 2, No. 4) clockwise. If the steak comes out too thin, turn the handwheel counter-clockwise.
7. A plastic film (vacuum pack or similar) may be placed on top of the steak to assist with spreading.
8. Never attempt to operate the machine without the guards in place and never put your hand underneath the press plate (Diagram 2, No. 5).
9. When you finish work, stop the operation of the machine by pressing the stop switch (Diagram 1, No. 1 b).

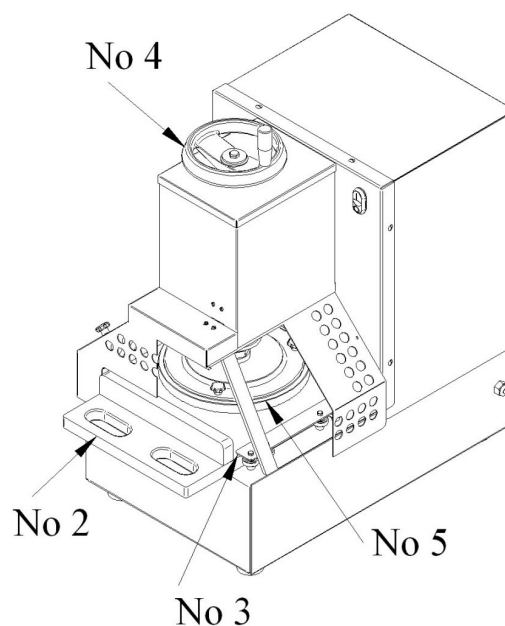

**Diagram 2**

## 6. Cleaning

### 6.1 Stopping

Stop the machine by pressing the stop switch (Diagram 1, No. 1b). **REMOVE THE PLUG FROM THE WALL SOCKET.**

### 6.2 Dismantling

1. Remove the plastic tray (Diagram 3, No. 2) from the machine.
2. Remove the front cover (Diagram 3, No. 6) by loosening the finger nuts (Diagram 3, No. 7) and pulling the cover off the machine. Handle the cover with care so as not to damage the tongue of the safety switch located in the cover.
3. Remove the plastic press plate (Diagram 3, No. 5) by loosening the three star knobs (Diagram 3, No. 8).

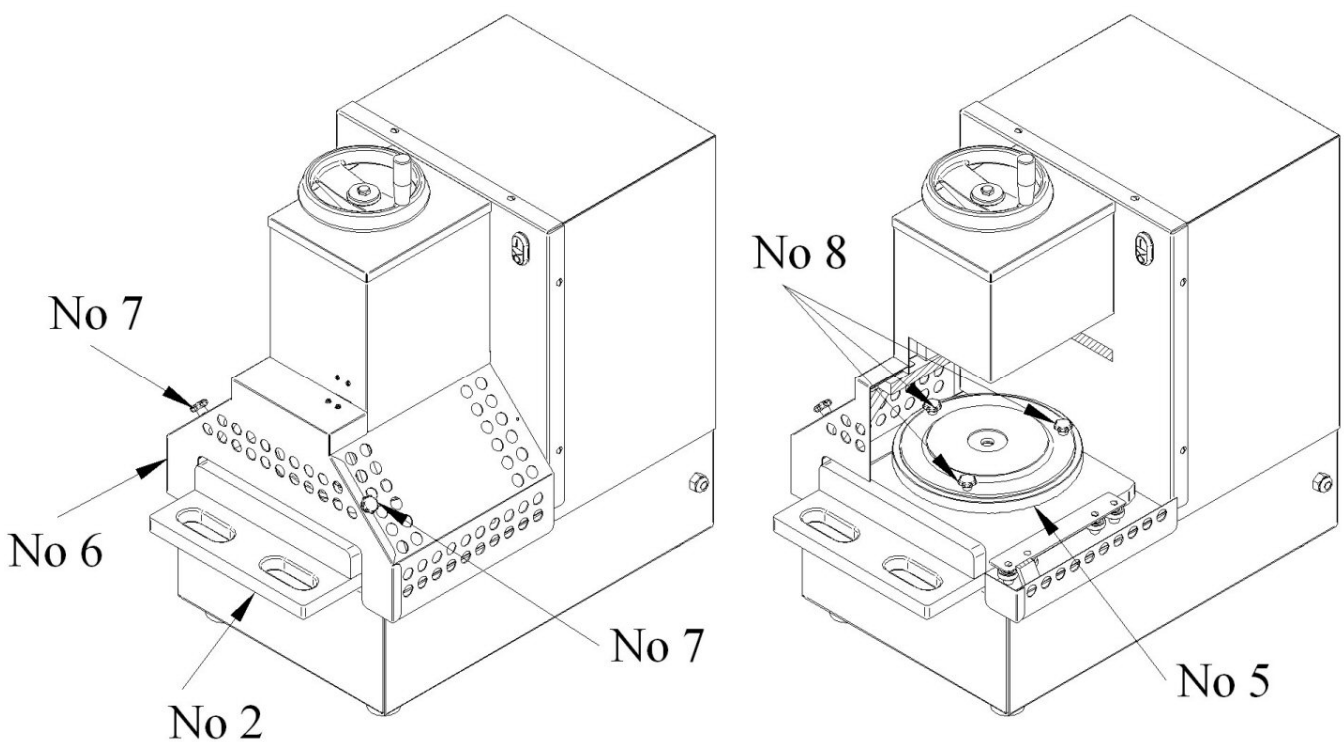

Diagram 3

### **6.3 Washing**

The machine's stainless steel surfaces may be wiped with a mild detergent.

**DO NOT USE A HOSE TO WASH THE MACHINE!**

### **6.4 Recommended detergents**

Mix, for instance, the following detergent with warm water (about + 20 °C):

*Kärcher RM 81*

Always rinse after washing. Whichever detergent or method you use, always follow the manufacturer's instructions. Do not exceed the recommended concentrations or soaking times.

If detergent, rinsing water or disinfectant remains in the meat press, it must be dried as appropriate.

## **7. Maintenance**

The machine does not have any components that require maintenance.

If the machine malfunctions or has a hydraulic leak, contact the manufacturer without delay. (The machine uses a vegetable-based hydraulic oil, which is approved for food use).

### **7.1 Results from noise emission tests**

Results of the noise emission measurements carried out in the place of operation:

Noise emission, weighting "A": 77 dB(A)

# ANNEX 1 Dimensional drawing

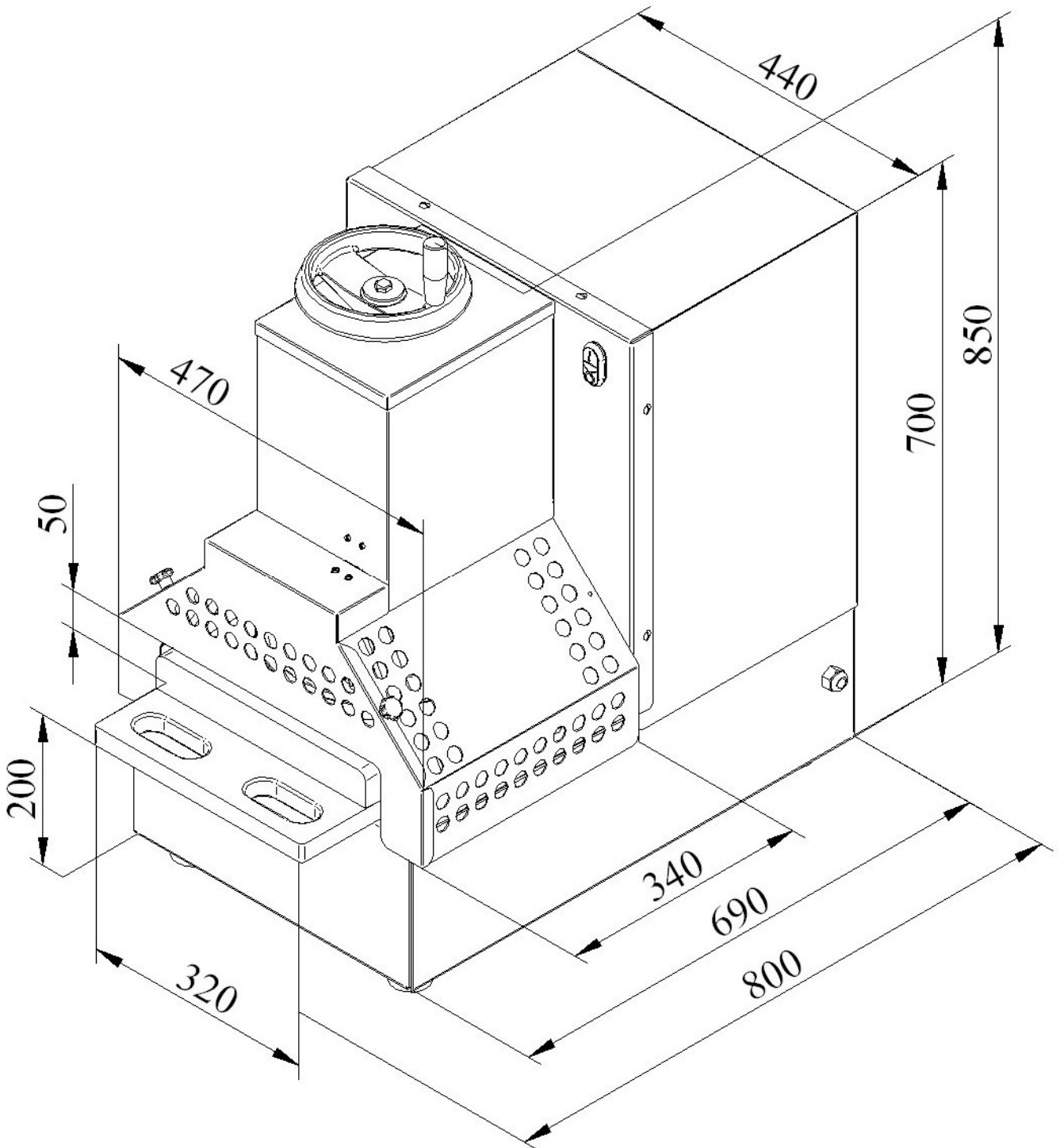

## ANNEX 2 Spare parts list

No.	Description	Note	Qty	No.	Description	Note	Qty
01	Handwheel		1	S1/S2/L1	Power switch		1
02	Finger nut		5	S3	Safety switch		1
03	Key for micro switch		1	S4 = S5	Magnetic switch		2
04	Front cover		1	TR	Time relay	MBA 88901328	1
05	Magnet		2	MV1	Magnetic valve		1
06	Plastic tray		1	C1	Contactora	DILM 9-10	1
07	Rubber foot		4	HR	Thermal overload relay	ZB 12-4	1
08	Horizontal cylinder support		1	R1 = R2	Relay	C10-A10X	2
09	Vertical cylinder support		2	F1	Fuse		1
10	Cylinder adjust nut		1	RE	Resistor		1
11	Cylinder lid		1	L2	Indication lamp		1
12	Cylinder adjusting screw		1				
13	Bushing		2				
14	Guide wedge		1				
15	Guide rail		2				
16	Bearing	SS 6200 2RS	9				
17	Guide bushing		8				
18	Press plate nut		1				
19	Press plate retainer		1				
20	Press plate, stainless		1				
21	Press plate bolt		1				
22	Press plate, plastic		1				
22.1	Press plate, plastic, smooth		1				
23	Cylinder top end		1				
24	Cylinder tube		1				
25	Guide ring	E/PWR 80x74x12,8	1				
26	Piston		1				
27	Spring		1				
28	Stop sleeve		1				
29	Guide ring	I/PWR 50x56x12,8	1				
30	Seal	UN 50x60x10 PU	1				
31	O-ring	OR 78,97x3,53 NBR70	2				
32	Cylinder end		1				
33	Wiper	AM 50x60x7/10 PU	1				
35	Support for plastic tray		1				
36	Thrust bearing	AXK 5070	1				
37	Guide ring	E/PWR 100x94x12,8	2				
38	Connection box		1				
39	Protective rubber		1				
40	Cable gland	M 20	1				
41	Cable		1				
42	Plug		1				
43	Side cover		2				
44	Top cover		1				
45	Cover plate		1				
46	Back cover		1				
47	Screw		3				
48	Holder for indication lamp		1				
100	Cylinder, complete set		1				

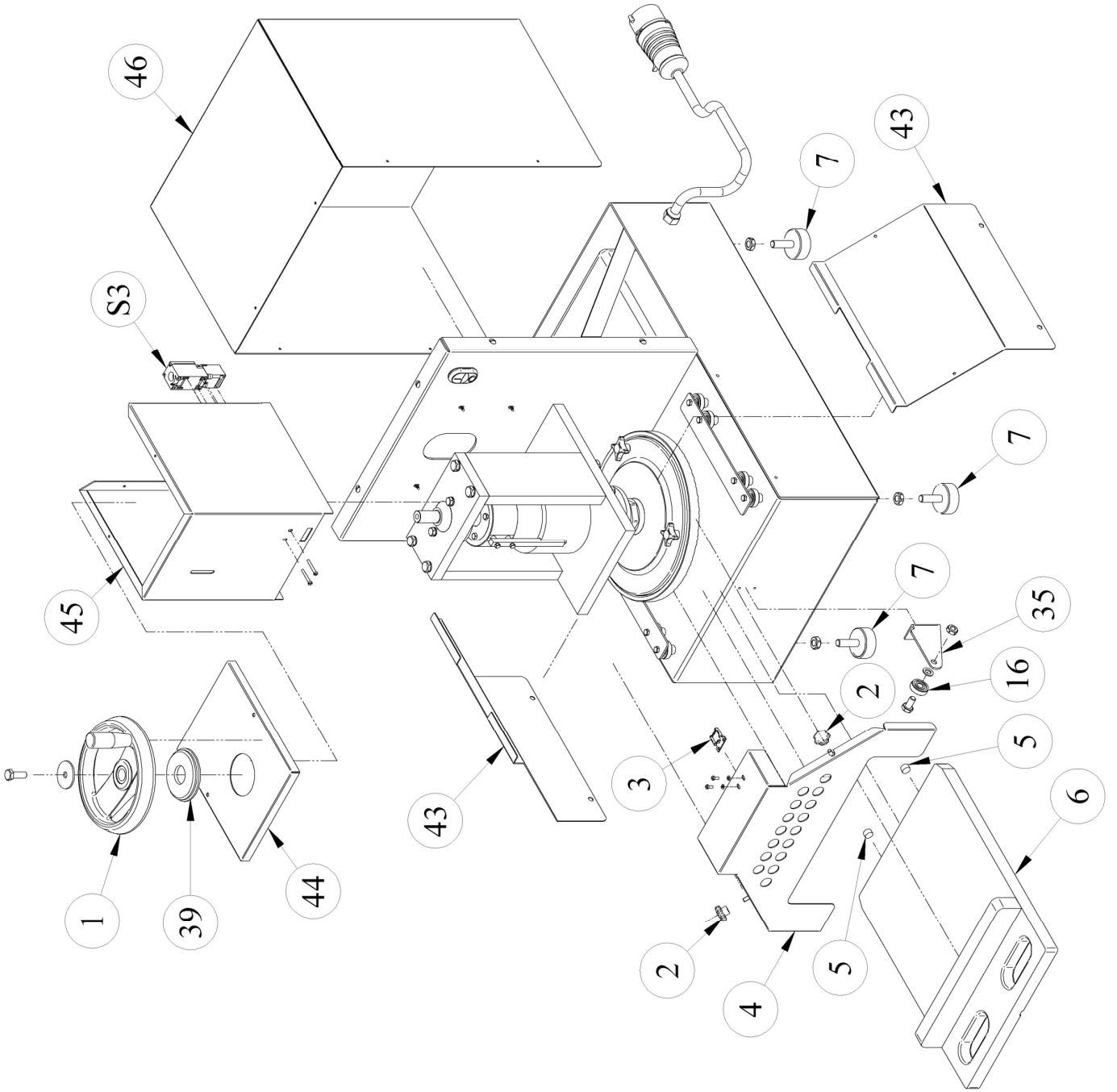



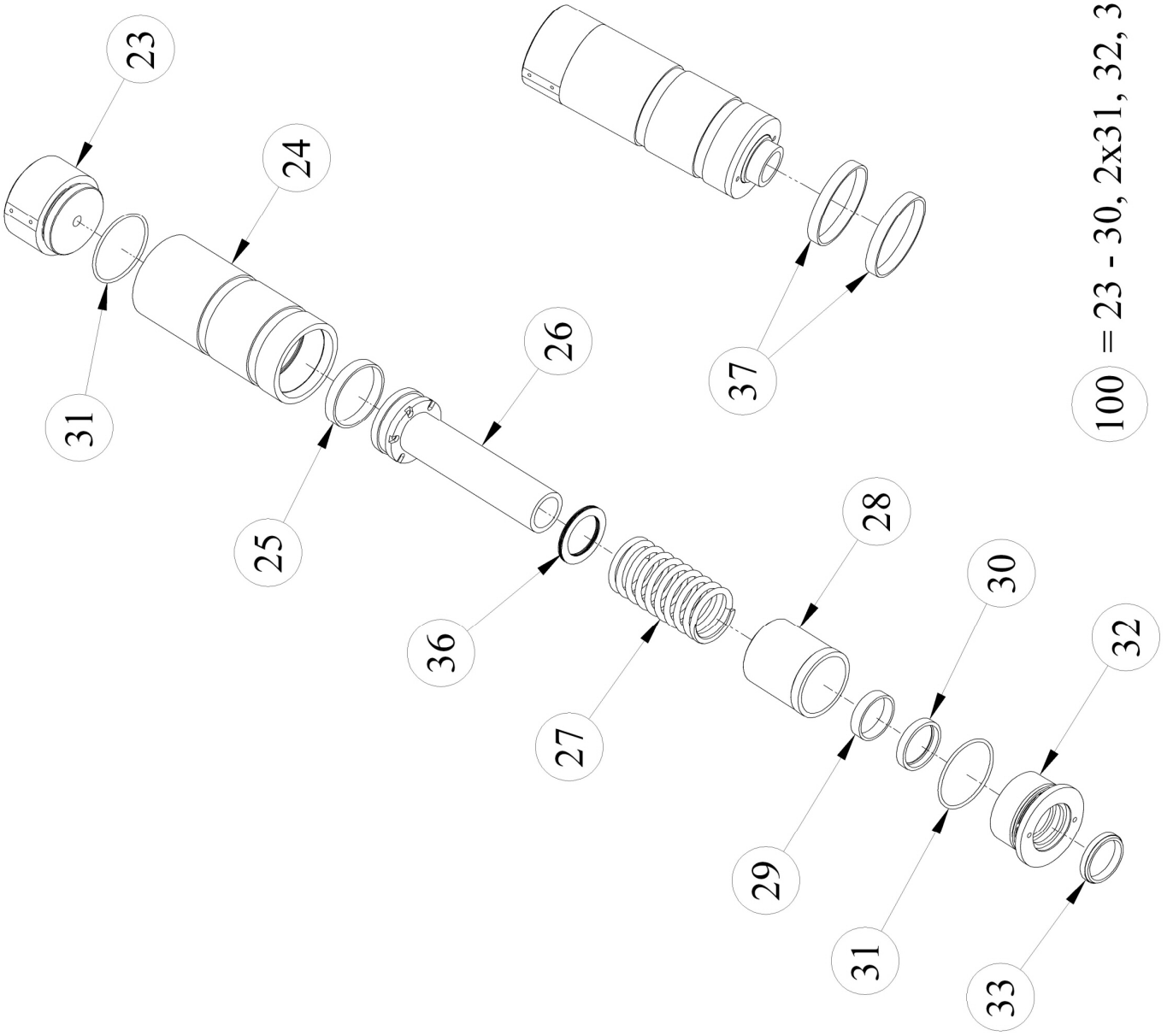

100 = 23 - 30, 2x31, 32, 33, 36, 2x37

# ANNEX 3 Switch diagram

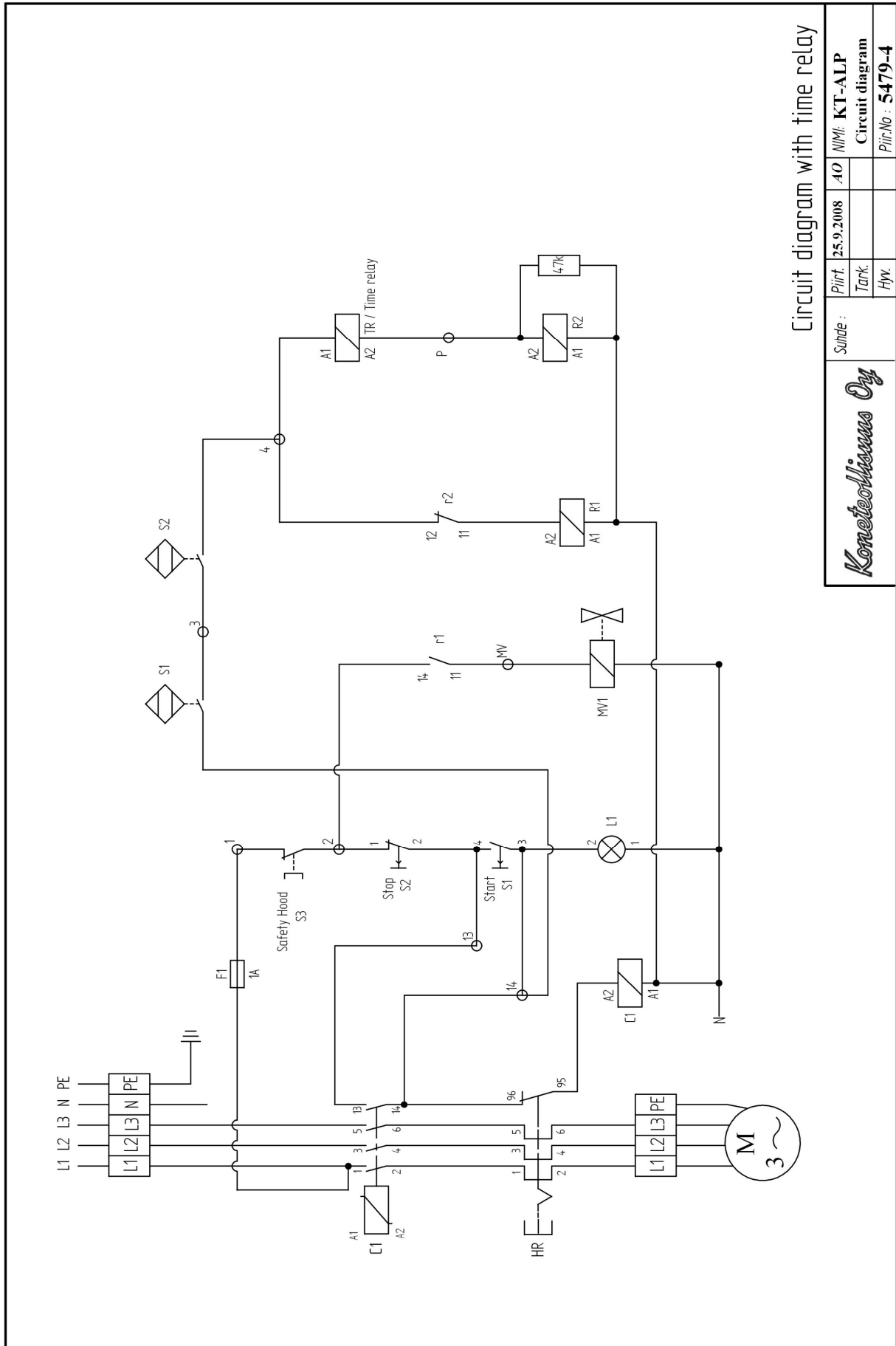

Circuit diagram with time relay

	Slide :	Pirt: 25.9.2008	AO	MIMI: KT-ALP
		Tank:		Circuit diagram
		Hvy:		Pirt.No : 5479-4