

INSTRUCTIONS FOR USE

SLICING MACHINE F-19S.

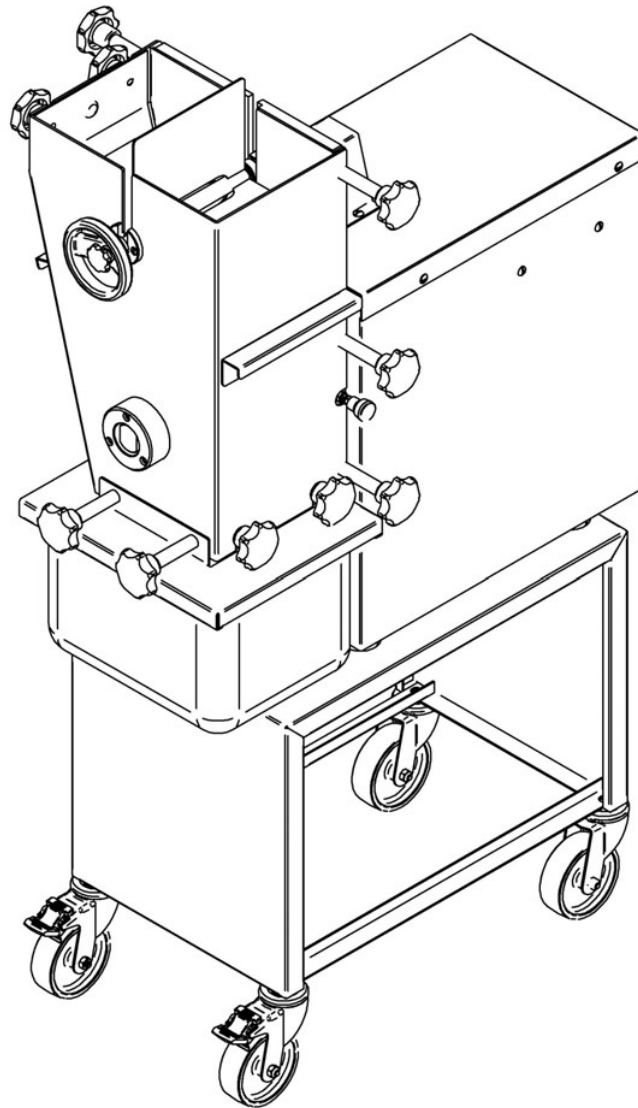

Jaccard Corporation
795 Beahan Road
Rochester, NY 14624
Tel: (866) 478-7373

SISÄLLYSLUETTELO

| | |
|---|-----------|
| 1. Introduction | 2 |
| 2. Technical specifications..... | 2 |
| 3. Installation..... | 3 |
| 3.1 Safety..... | 3 |
| 3.2 Starting and stopping..... | 4 |
| 3.3 Operation instructions | 5 |
| 4. Cleaning | 6 |
| 5. Care and maintenance..... | 8 |
| APPENDIX 1 Fault finding | 9 |
| APPENDIX 2 Dimensional drawing..... | 10 |
| APPENDIX 3 Circuit diagram..... | 11 |
| APPENDIX 4 Spare parts list | 12 |
| APPENDIX 5 Quantity of the blades and spacers..... | 24 |

1. Introduction

Slicing machine F-19S is developed especially for use in the retail and wholesale trade as well as in industry. As the slicer is constructed of stainless materials it will remain clean and in good condition for a long time. This guarantees a long life and trouble free operation.

This machine is intended specifically for cutting meat slices, strips and cubes. Also cutting slices of liver is made fast and easy with this slicer.

Because of the simple construction the machine is easy to disassemble, which enables easy maintenance and cleaning.

Due to the automatic cutting process, there is no need for any special pushing device that might damage the blades or lead to cutting fingers.

Only use the machine for its intended purpose. If misused, the machine can inflict damage to the user.

2. Technical specifications

| | |
|------------------|-------------------------|
| Power | 1,5 kW |
| Voltage | 400 V / 50 Hz / 3-phase |
| Current | 4,3 A |
| Rotational speed | 1000 1/min (motor) |

Measures of the machine:

| | |
|--------|--------|
| Height | 710 mm |
| Width | 500 mm |
| Depth | 770 mm |
| Weight | 85 kg |

Measures of the table:

| | |
|--------|--------|
| Height | 515 mm |
| Width | 400 mm |
| Depth | 700 mm |
| Weight | 11 kg |

Size of the blade: Ø 200 mm x 1,2 mm (7-7/8 x 1/21 in)

The machine is equipped with a low voltage control relay, thermal relay and direction control switch.

3. Installation

3.1 Safety

It is recommended, that all users must be given the correct training in the safe use of the meat press.

All users must read these operating instructions before usage of the machine.

Your personal safety is more important than the quick operation of the machine.

The machine must be installed on a flat surface. The machine must be installed in a place where there is sufficient room to work around the machine and enough light to allow safe working. For the safety of the operator, the floor must have a non-slip surface. If the optional table is used, the machine must be locked to the table with a fixing screw (see page 23)

When handling the set of blades, it is recommended to use protective gloves.

If the action of the machine seems abnormal, stop the machine immediately and contact service personnel or the manufacturer.

3.2 Starting and stopping

The machine can be started by pressing the white start switch (Picture 1, No. 1a).

The machine may be stopped as follows:

1. by pressing the BLACK stop switch (No. 1b).
2. in the case of emergency by pressing the EMERGENCY SWITCH (No. 1c)

Check the correct direction of rotation. When viewed from the end of the shaft, the set of blades should rotate counter clockwise. If necessary, change the direction of rotation with the direction control switch (No. 2). The direction control switch operates also as a main power switch.

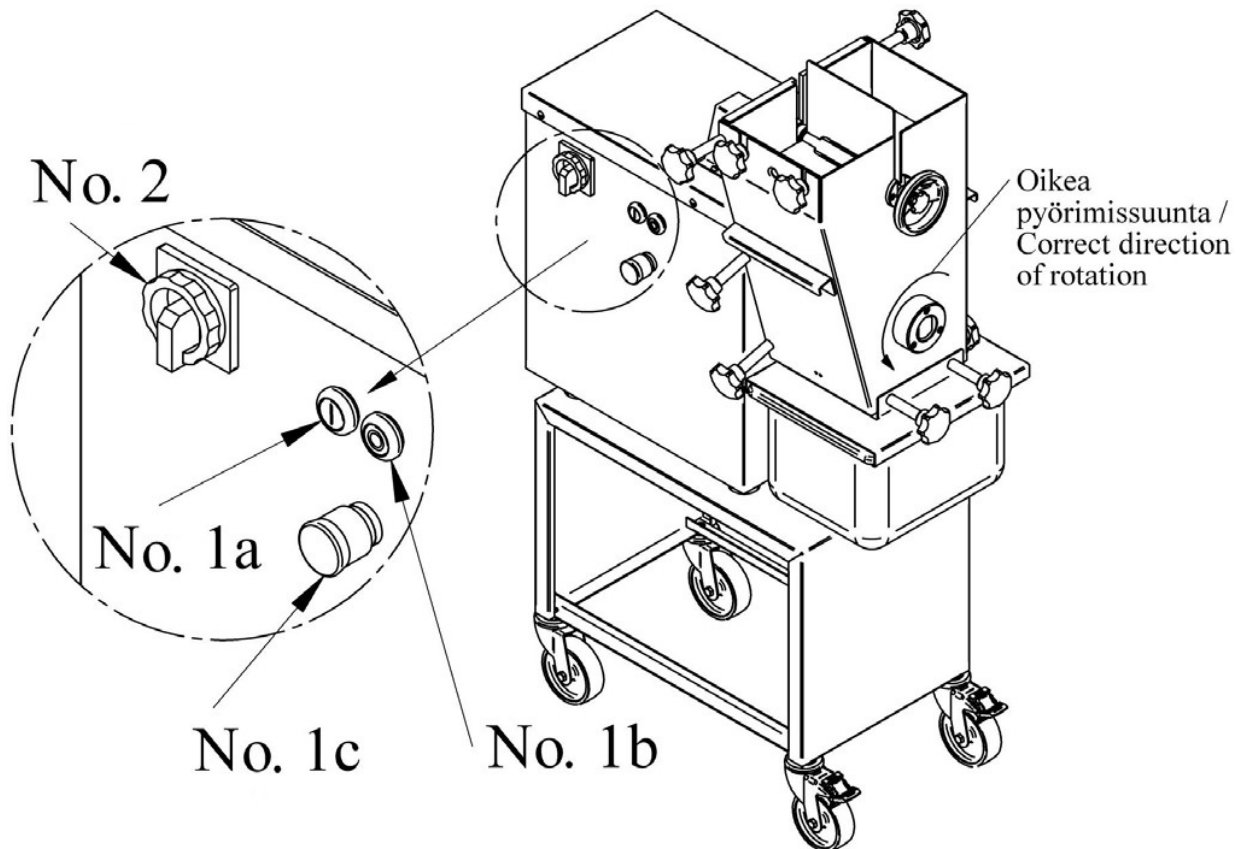

Picture 1. Push buttons.

3.3 Operation instructions

The machine must be cleaned thoroughly before use (see Chapter 4, Cleaning).

1. Cut excess fat and hard tendons and gristle away from the meat to be processed. Cut the meat into 1–1,5 kg pieces.
2. Check that the upper and lower combs are assembled correctly. Also check that the turn knobs are properly tightened.
3. Slide the meat container into place and start the machine. Check the correct direction of rotation before putting the meat into the slicer. If necessary, change the direction of rotation with the direction control switch (see Chapter 3.2). When viewed from the end of the shaft the blades should rotate counter clockwise.
4. Place the meat on top of the finger protecting paddle-wheel, from which it will drop into the blade housing. The blades will automatically pull the meat into the blade housing immediately cutting it. The slices of the meat will drop into the meat container.
5. When cutting the meat for the second time, place the slices on the wing of the

paddle-wheel while holding the knob with the other hand so the paddle-wheel stays still. When the meat slices are in their proper place, rotate the paddle-wheel and the meat will drop into the blade housing. The blades cut the slices into strips which will drop into the meat container underneath.

6. When making meat cubes cut the meat for a third time following the procedure above.
7. After use turn the power off, disassemble the blade housing and clean it thoroughly (see Chapter 4).

4. Cleaning

The cleaning procedure may be performed only a person, who is trained for the operation. To make the cleaning easier the machine must be disassembled:

- Step 1: Turn the power off and remove the plug from the wall socket.
- Step 2: Remove the meat container (Picture 2, No. 3)
- Step 3: Remove the lock plate of the meat container by unfastening the hand knobs (No. 4 and 5).
- Step 4: Upper and lower combs will be removed by loosening the hand knobs (No. 6, 7, 8 and 9). Lift the upper comb upwards to remove it. Push the lower comb downwards and it will come loose.
- Step 5: The paddle wheel (No. 10) may be removed by lifting it upwards along the groove.
- Step 6: Loosen the rest of the hand knobs (No. 11, 12 and 13) and pull the plates outwards by lifting from the supporting rails (No. 14). The set of blades will remain in the machine.
- Step 7: Lift the set of blades with the special hook, pull out the safety tenon (No. 15) and remove the set of blades putting it on the washing stand. Clean the blades with the brush that comes with the machine. The set of blades may also be dismantled if necessary. To make this easier, two grooves have been milled into the shaft of the blade set preventing the shaft from turning while opening the nut e.g. with a spanner.

Assembling the machine is done in reverse. While assembling the paddle wheel, make sure that the key for the safety switch is placed correctly into the safety switch and the set of blades locks in place (safety tenon, No. 14). Always check that the safety tenon works properly.

All removed parts can be washed e.g. in a washer or by hand with soap solution. Wipe the machine using a soft towel and mild soap solution. Do not use a hose to wash the machine.

NOTE! Always switch off the power before cleaning.

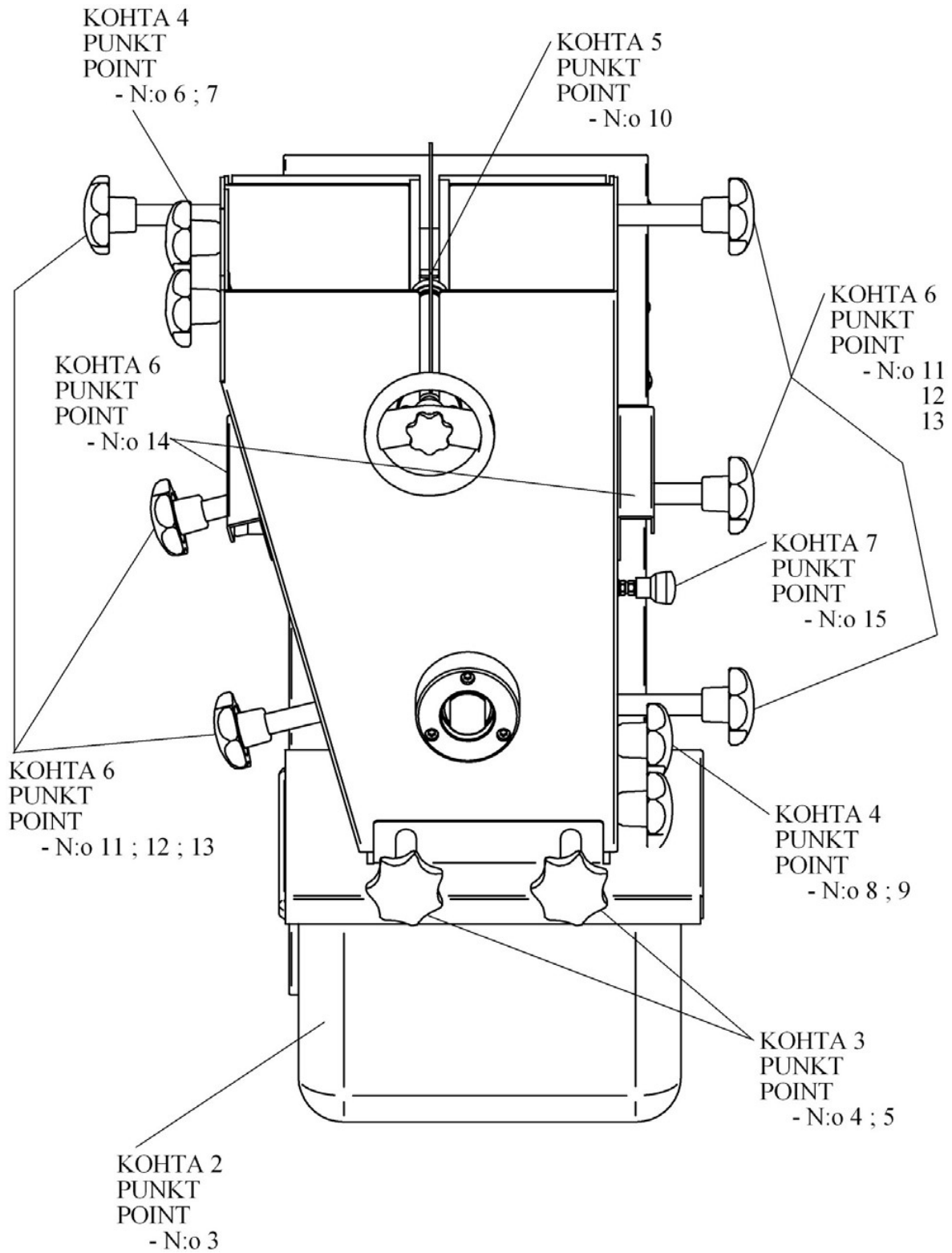

Picture 2. Disassembling the machine and cleaning.

5. Care and maintenance

There are no special parts requiring maintenance. The sharpness of the blades should be checked periodically and the blades must be sharpened if necessary.

The manufacturer also provides a sharpening service.

The blades of the machine may be damaged if inappropriate items (e.g. tools) are dropped into the blade housing while the machine is running.

Yhdistetty säilytys- ja pesulaatikko

Combined storing and cleaning box

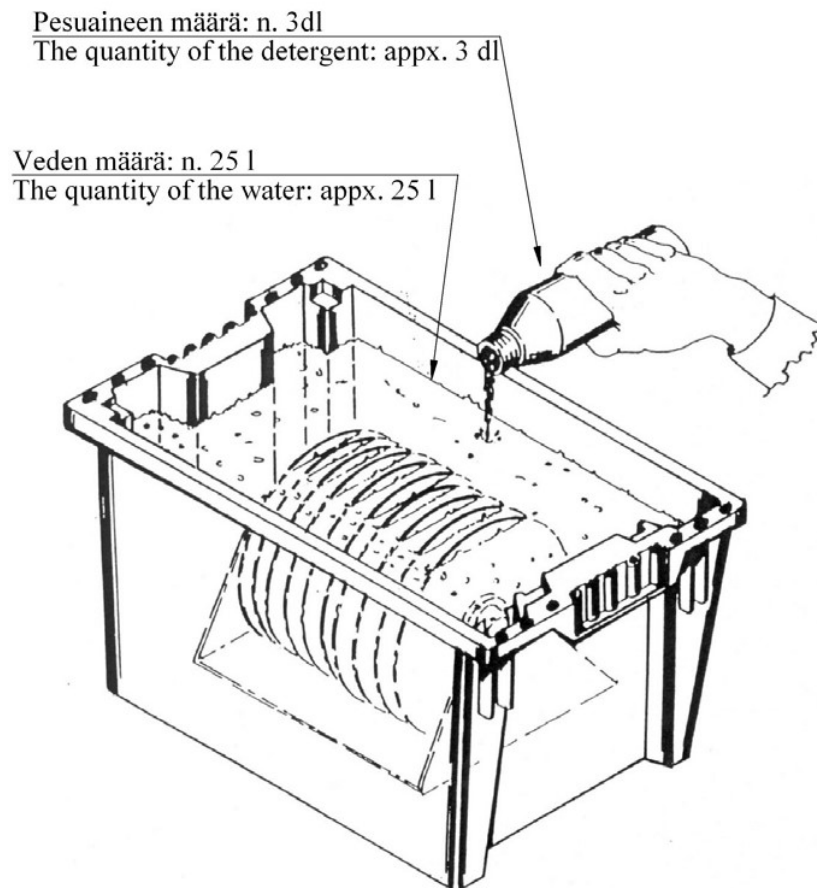

Picture 3. Storing and cleaning box.

APPENDIX 1 Fault finding

| FAULT | REASON | SOLUTION |
|---|--|--|
| The machine will not start | <ul style="list-style-type: none"> a) Emergency switch is pressed down b) The direction control switch is positioned to "0" c) The safety switch of the paddle wheel is not connected correctly d) The meat container is not placed in its place | <ul style="list-style-type: none"> a) Lift up the emergency switch b) Turn the switch to the correct position c) Check the assembly of the paddle wheel d) Slide the meat container into its place |
| The machine starts up, but the blades doesn't rotate | The cog belt is broken. | Contact service or the manufacturer. |
| The set of blades rotates, but the machine doesn't slice meat | The direction of the rotation is incorrect. | Change the direction of rotation with the direction control switch. |

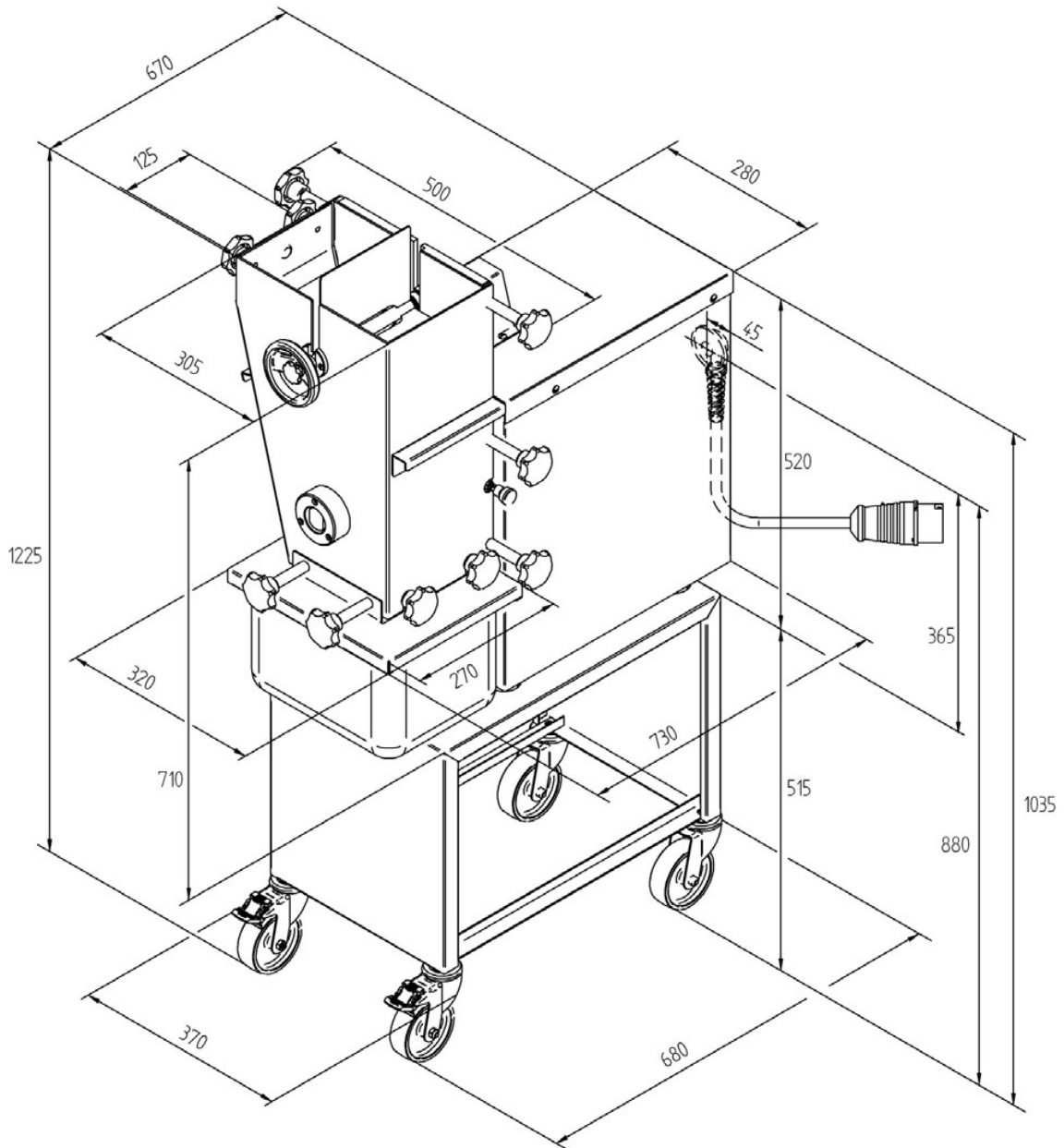
APPENDIX 2 Dimensional drawing

APPENDIX 3 Circuit diagram

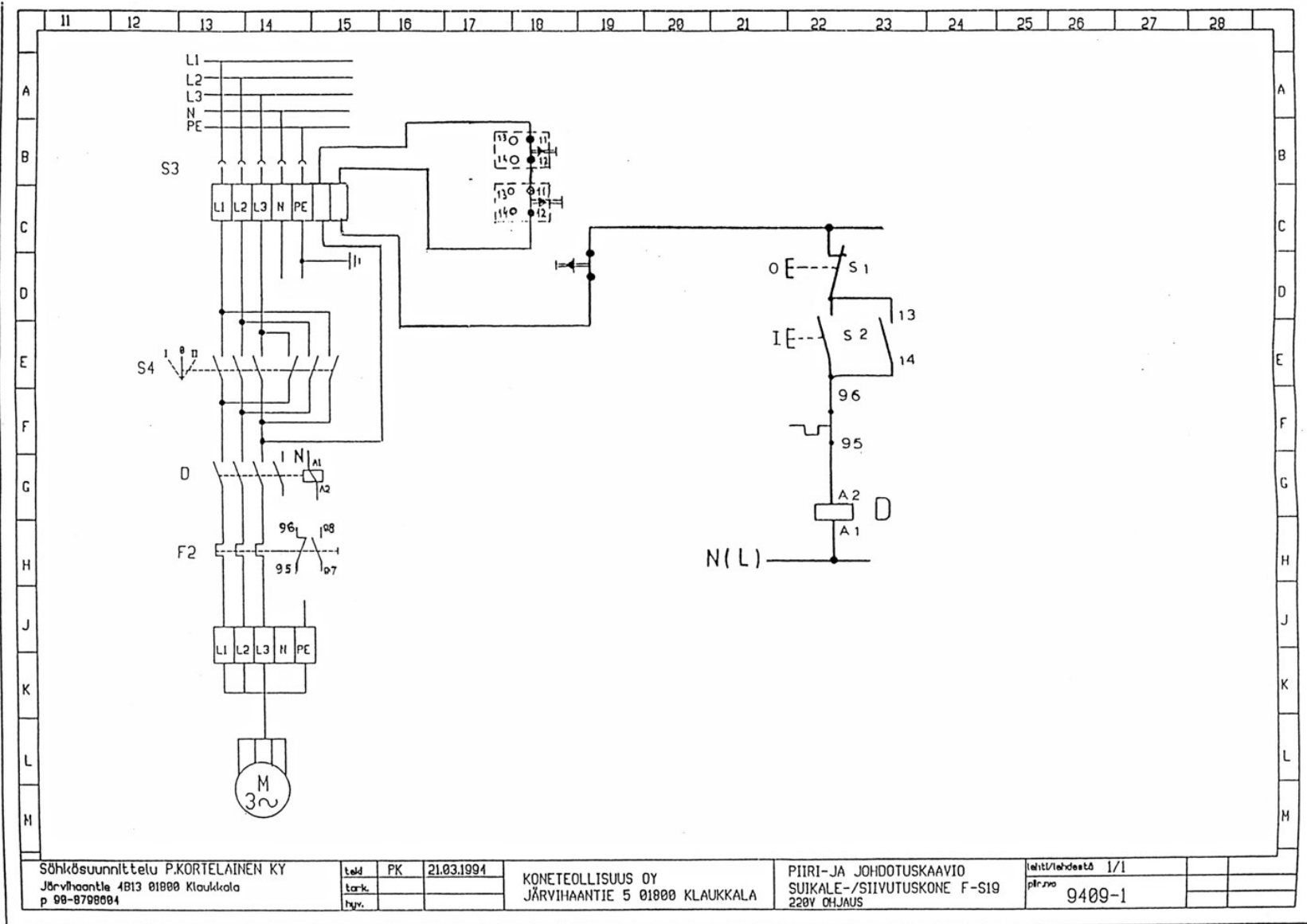

APPENDIX 4 Spare parts list

| <u>PART NUMBER</u> | <u>PART NAME</u> | <u>QUANTITY</u> |
|--------------------|---------------------------------|-----------------|
| 1901 | FRONT PLATE | 1 |
| 01/1 | FRONT PLATE | 1 |
| 02 | SIDE PLATE, LEFT | 1 |
| 03 | SIDE PLATE, RIGHT | 1 |
| 04 | PADDLE WHEEL | 1 |
| 04/1 | PADDLE WHEEL | 1 |
| 05 | BUSHING FOR THE PADDLE WHEEL | 1 |
| 06 | PIN | 1 |
| 07 | HAND KNOB | 8 |
| 08 | HAND KNOB FOR THE BLADE COMBS | 4 |
| 09 | WASHERS | 2 |
| 10 | BEARING FOR THE BLADE SET SHAFT | 1 |
| 11 | TURN WHEEL KNOB | 1 |
| 12 | THUMB SCREW | 1 |
| 13 | SCREW | 2 |
| 14 | BACK PLATE | 1 |
| 14/1 | BACK PLATE, PLASTIC | 1 |
| 14/2 | BACK PLATE, STAINLESS STEEL | 1 |
| 15 | BEARING | 1 |
| 15/1 | BEARING | 1 |
| 16 | SCREW | 6 |
| 17 | SPACER PLATE | 1 |
| 18 | DRIVE SHAFT GASKET | 1 |
| 19 | FRAME | 1 |
| 20 | GUIDE PIN | 1 |
| 21 | DRIVE SHAFT | 1 |
| 22 | KEY | 1 |
| 23 | DRIVE SHAFT BEARING | 1 |
| 24 | BEARING BLOCK | 1 |
| 25 | BEARING | 1 |
| 26 | CIRCLIP | 1 |
| 27 | COG BELT | 1 |
| 28 | COG BELT PULLEY | 1 |
| 29 | COG BELT PULLEY | 1 |
| 30 | KEY | 1 |
| 31 | MOTOR | 1 |
| 32 | RUBBER PAD FOR LEGS | 4 |
| 33 | KNOB | 1 |
| 34 | NUT | 2 |
| 35 | SUPPORT FOR SPRING | 1 |
| 36 | SPRING | 1 |
| 37 | SAFETY TENON | 1 |
| 2000 | CIRCLIP | 1 |
| 01 | BEARING | 1 |
| 02 | CIRCLIP | 1 |
| 03 | BUSHING | 1 |

| <u>PART NUMBER</u> | <u>PART NAME</u> | <u>QUANTITY</u> |
|-----------------------|-------------------------------|-----------------|
| <u>SETS OF BLADES</u> | | |
| 1938 | UPPER COMB STAINLESS (9 mm) | 1 |
| 39 | NUT FOR BLADE SET | 1 |
| 40 | SET OF BLADES (9 mm) | 1 |
| 41 | BLADE SPACER | 1 |
| 42 | BLADE | 19 |
| 43 | BLADE SPACER (9 mm) | 18 |
| 44 | BLADE SET SHAFT | 1 |
| 45 | LOWER COMB PLASTIC | 1 |
| 1946 | SET OF BLADES (18 mm) | 1 |
| 38 | UPPER COMB STAINLESS | 1 |
| 39 | NUR FOT BLADE SET | 1 |
| 41 | BLADE SPACER | 1 |
| 42 | BLADE | 10 |
| 44 | BLADE SET SHAF | 1 |
| 47 | BLADE SPACER (18 mm) | 9 |
| 1948 | SET OF BLADES (27 mm) | 1 |
| 38 | UPPER COMB STAINLESS | 1 |
| 39 | NUT FOR BLADE SET | 1 |
| 41 | BLADE SPACER | 1 |
| 42 | BLADE | 7 |
| 44 | BLADE SET SHAF | 1 |
| 49 | BLADE SPACER (27 mm) | 6 |
| 1950 | SET OF BLADES (12 mm) | 1 |
| 39 | NUT FOR BLADE SET | 1 |
| 42 | BLADE | 15 |
| 44 | BLADE SET SHAF | 1 |
| 51 | BLADE SPACER (12 mm) | 1 |
| 52 | BLADE SPACER (12 mm) | 14 |
| 53 | LOEWR COMB PLASTIC (12 mm) | 1 |
| 54 | UPPER COMB STAINLE (12 mm) | 1 |
| 1955 | SET OF BLADES (24 mm) | 1 |
| 39 | NUT FOR BLADE SET | 1 |
| 42 | BLADE | 8 |
| 44 | BLADE SET SHAF | 1 |
| 51 | BLADE SPACER | 1 |
| 56 | BLADE SPACER (24 mm) | 7 |
| 53 | LOWER COMB PLASTIC | 1 |
| 54 | UPPER COMB STAINLE | 1 |
| 1957 | SET OF BLADES (6 mm) | 1 |
| 39 | NUT FOR BLADE SET | 1 |
| 42 | BLADE | 29 |
| 44 | BLADE SET SHAFT | 1 |
| 58 | BLADE SPACER (6 mm) | 1 |
| 59 | BLADE SPACER (6 mm) | 28 |
| 60 | LOWER COMB PLASTIC (6 mm) | 1 |
| 61 | UPPER COMB STAINLESS (6 mm) | 1 |

| <u>OSANUMERO</u> | <u>NIMIKE</u> | <u>KPL</u> |
|------------------|-------------------------------|------------|
| 2011 | SET OF BLADES (4 mm) | 1 |
| 12 | BLADE SPACER (4 mm) | 37 |
| 13 | BLADE SPACER (4 mm) | 1 |
| 14 | LOWER COMB PLASTIC (4 mm) | 1 |
| 15 | UPPER COMB PLASTIC (4 mm) | 1 |
| 16 | UPPER COMB STAINLESS (4 mm) | 1 |
| 1939 | NUT FOR BLADE SET | 1 |
| 42 | BLADE | 38 |
| 44 | BLADE SET SHAFT | 1 |
| 1962 | SIDE COVER | 1 |
| 63 | TOP COVER | 1 |
| 64 | BRACKET FOR MICRO SWITCH | 1 |
| 65 | MICRO SWITCH | 1 |
| 65/1 | MICRO SWITCH | 1 |
| 66 | START BUTTON | 1 |
| 67 | STOP BUTTON | 1 |
| 68 | CONTACTOR BOX COVER | 1 |
| 69 | RUBBER COVER | 1 |
| 70 | RUBBER COVER | 1 |
| 71 | CONTACTOR | 1 |
| 71/1 | CONTACTOR | 1 |
| 72 | THERMAL RELAY | 1 |
| 72/1 | THERMAL RELAY | 1 |
| 73 | CONTACTOR BOX | 1 |
| 74 | NUT | 1 |
| 75 | CABLE GLAND | 1 |
| 76 | MICRO SWITCH | 1 |
| 77 | DIRECTIONAL CONTROL SWITCH | 1 |
| 77/1 | MAIN POWER SWITCH | 1 |
| 78 | ATTACHMENT PLATE FOR SWITCH | 1 |
| 79 | PROTECTIVE PLATE FOR SWITCH | 1 |
| 80 | SWITCH KNOB | 1 |
| 81 | SHEET METAL | 1 |
| 82 | PUSHER FOR MICRO SWITCH | 1 |
| 83 | SUPPORT | 1 |
| 84 | CABLE GLAND | 1 |
| 85 | NUT | 1 |
| 86 | CABLE GLAND | 1 |
| 87 | PLUG | 1 |
| 2004 | BLOCK, NC | 1 |
| 05 | BLOCK, NO | 2 |
| 06 | CLIP (ADAPTER) | 3 |
| 07 | EMERGENCY SWITCH | 1 |
| 08 | STOP BUTTON | 1 |
| 09 | START BUTTON | 1 |
| 10 | RUBBER COVER | 2 |

| <u>OSANUMERO</u> | <u>NIMIKE</u> | <u>KPL</u> |
|------------------|--------------------------------|------------|
| 1988 | STAINLESS STAND | 1 |
| 89 | TURNING WHEEL FOR STAND | 2 |
| 90 | FIXED WHEEL FOR STAND | 2 |
| 91 | LIFTING HOOK FOR THE BLADE SET | 1 |
| 92 | WASHING STAND | 1 |
| 93 | DETERGENT | 1 |
| 94 | BRUSH (9 mm) | 1 |
| 95 | BRUSH (18 mm) | 1 |
| 96 | BRUSH (27 mm) | 1 |
| 97 | THUMB SCREW | 2 |
| 98 | LOCK PLATE FOR MEAT CONTAINER | 1 |
| 99 | MEAT CONTAINER | 1 |
| 19100 | FEEDING VESSEL | 1 |
| 01 | SUPPORT STEEL | 1 |

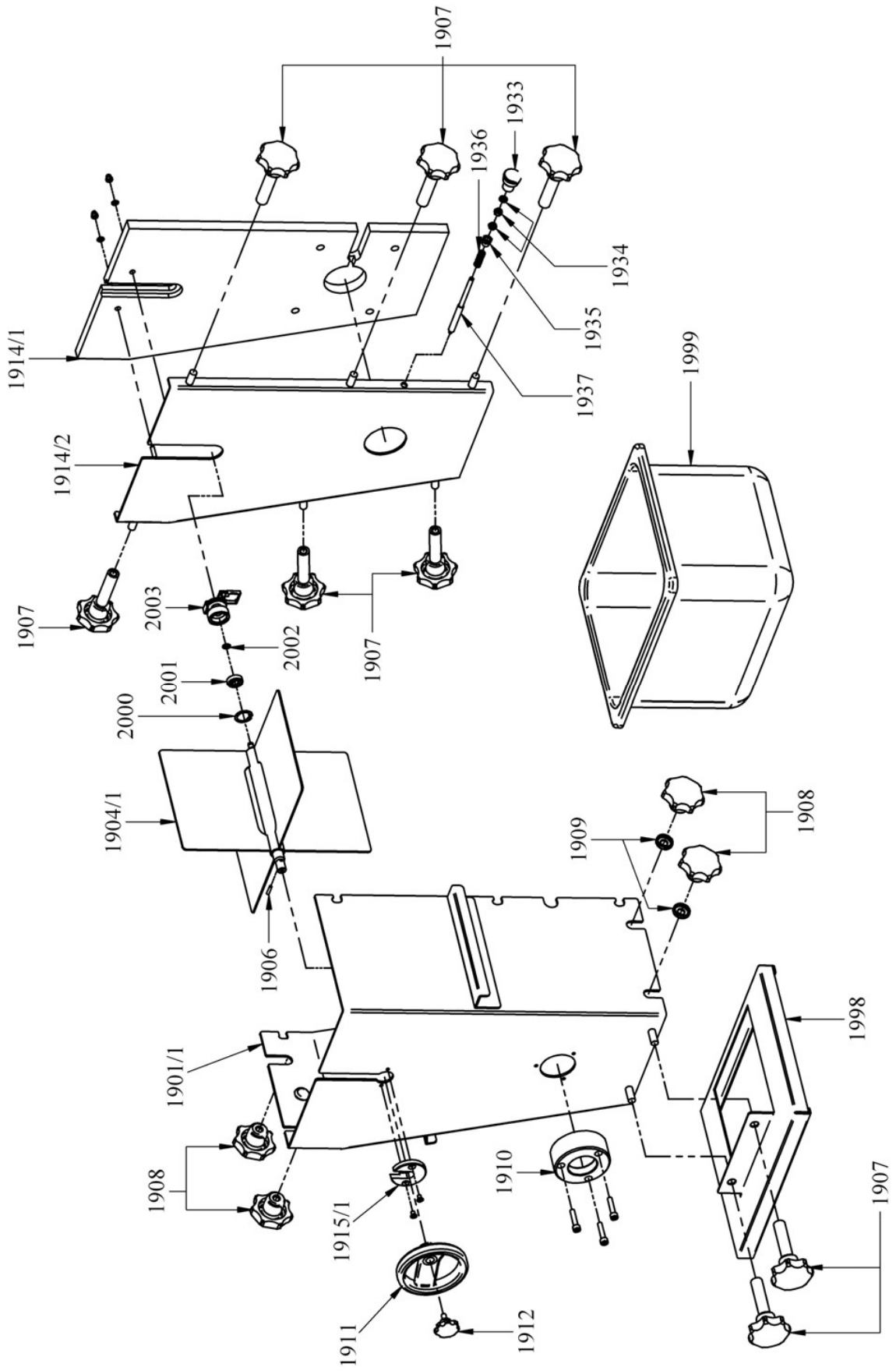

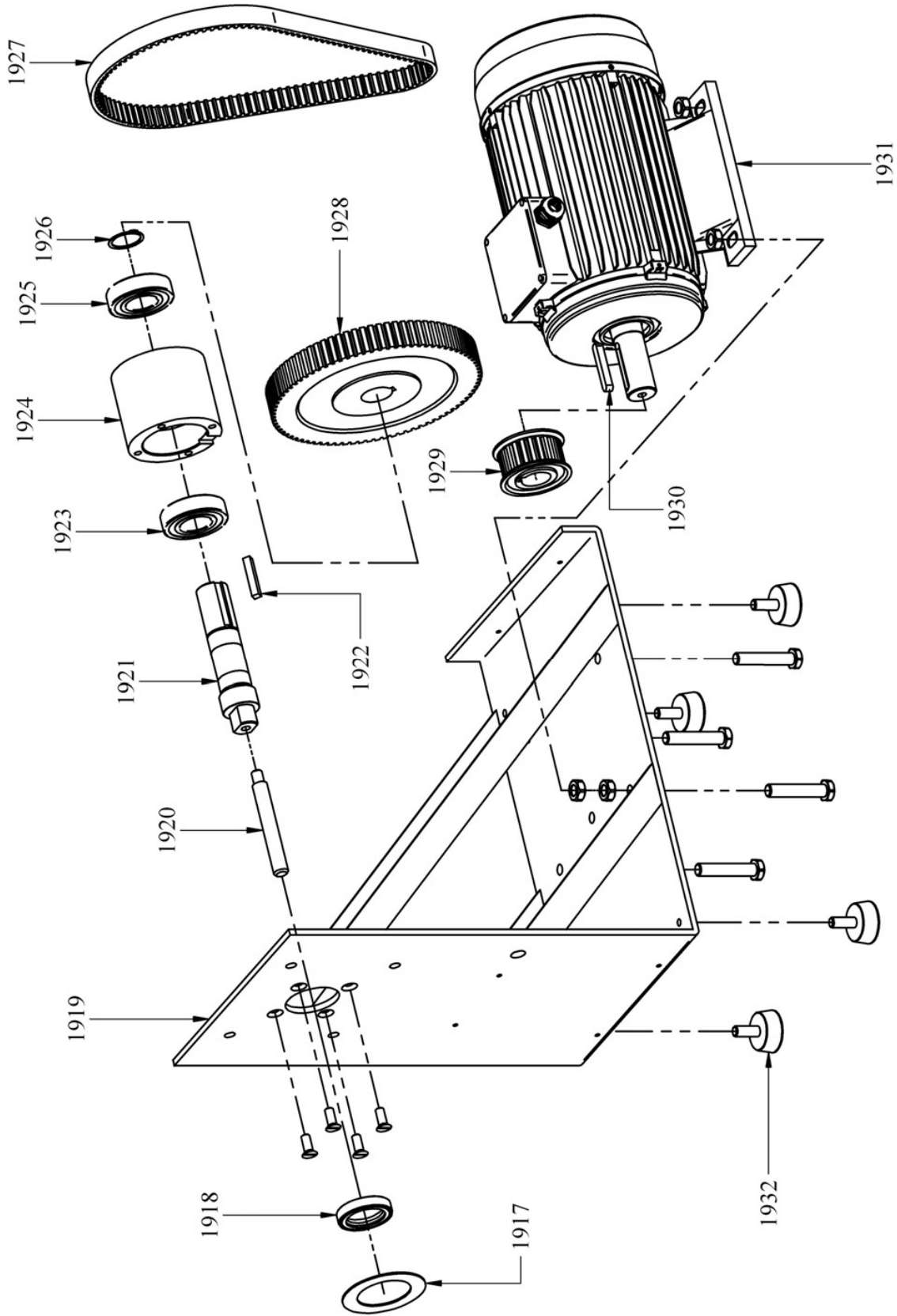

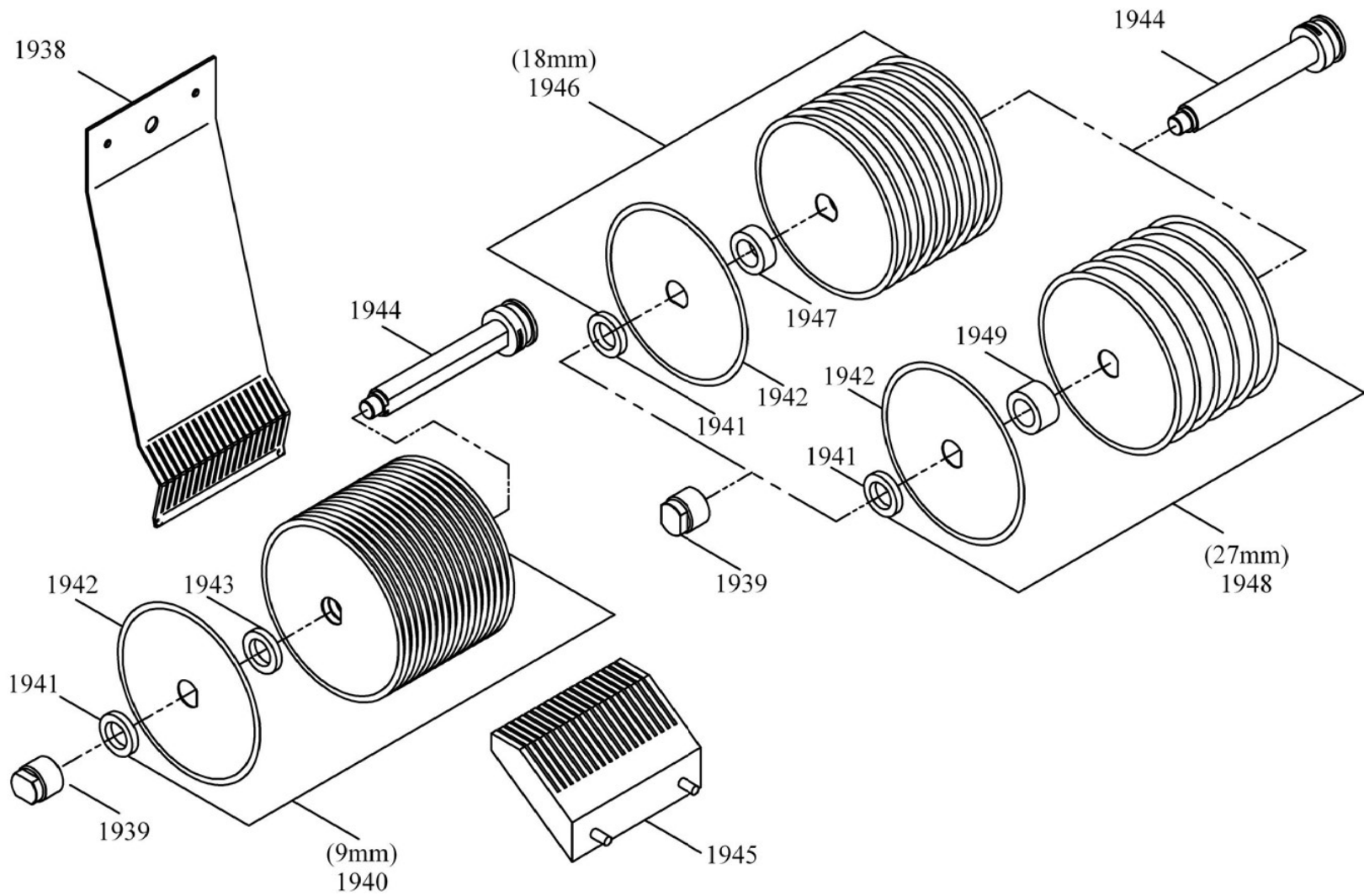

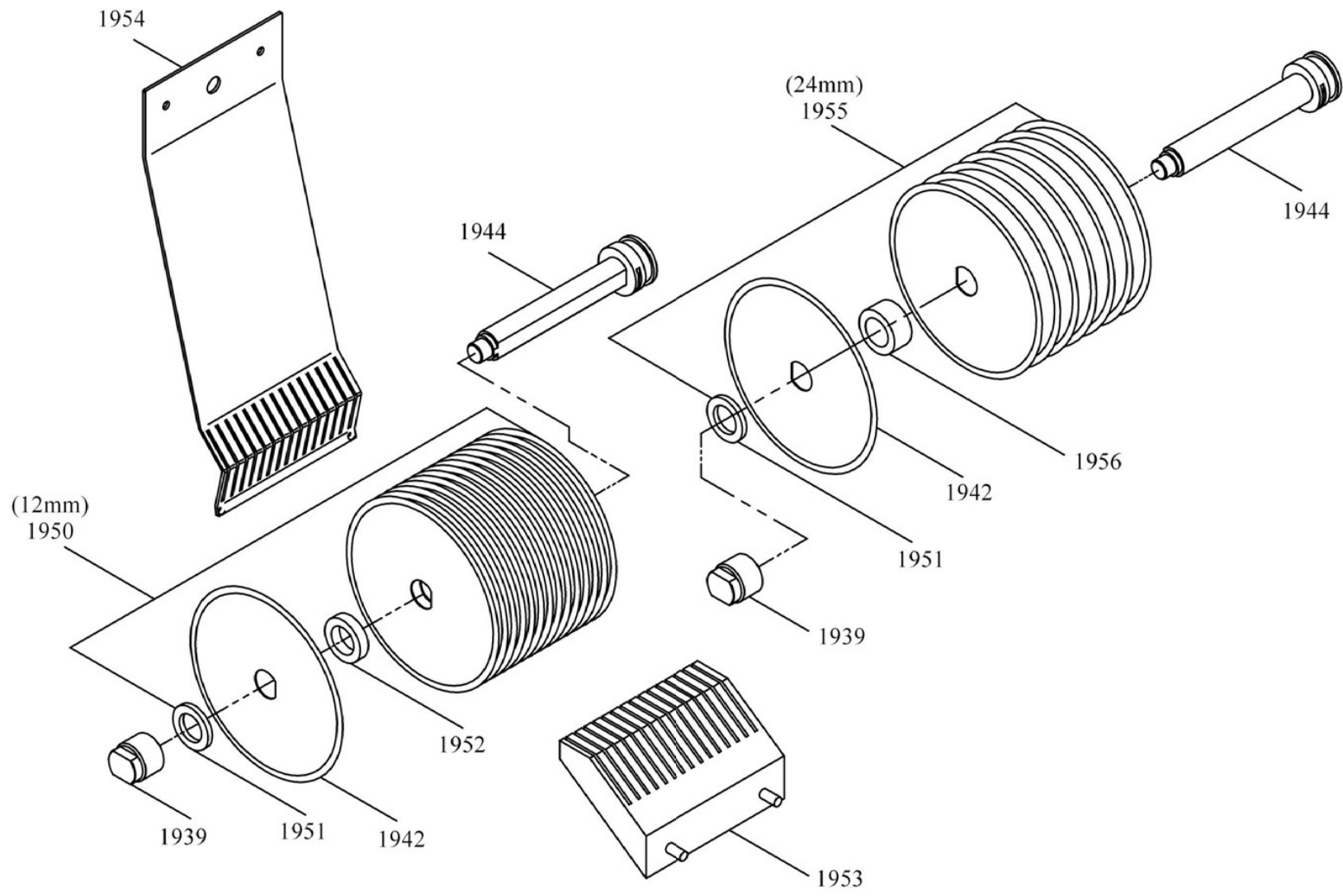

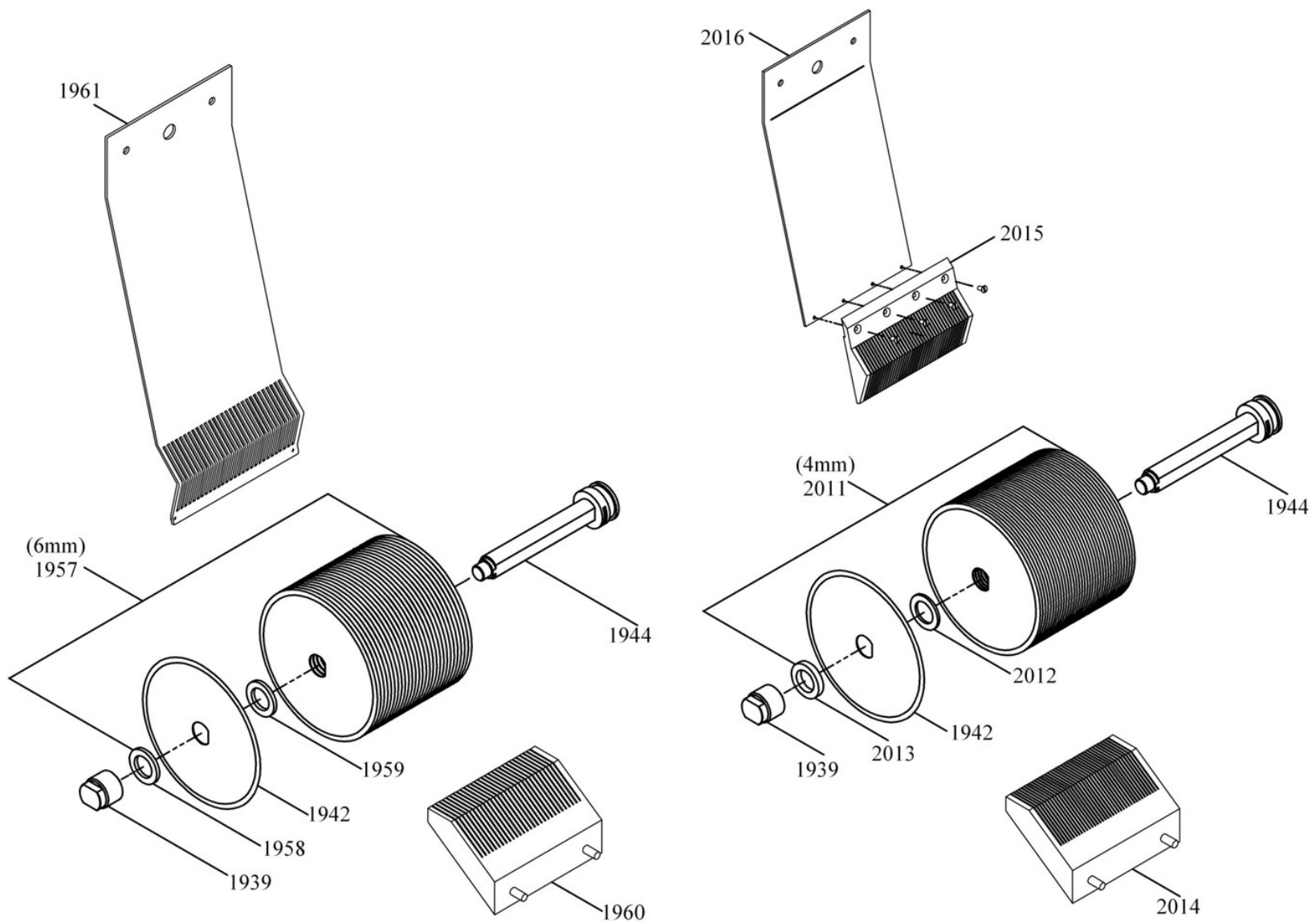

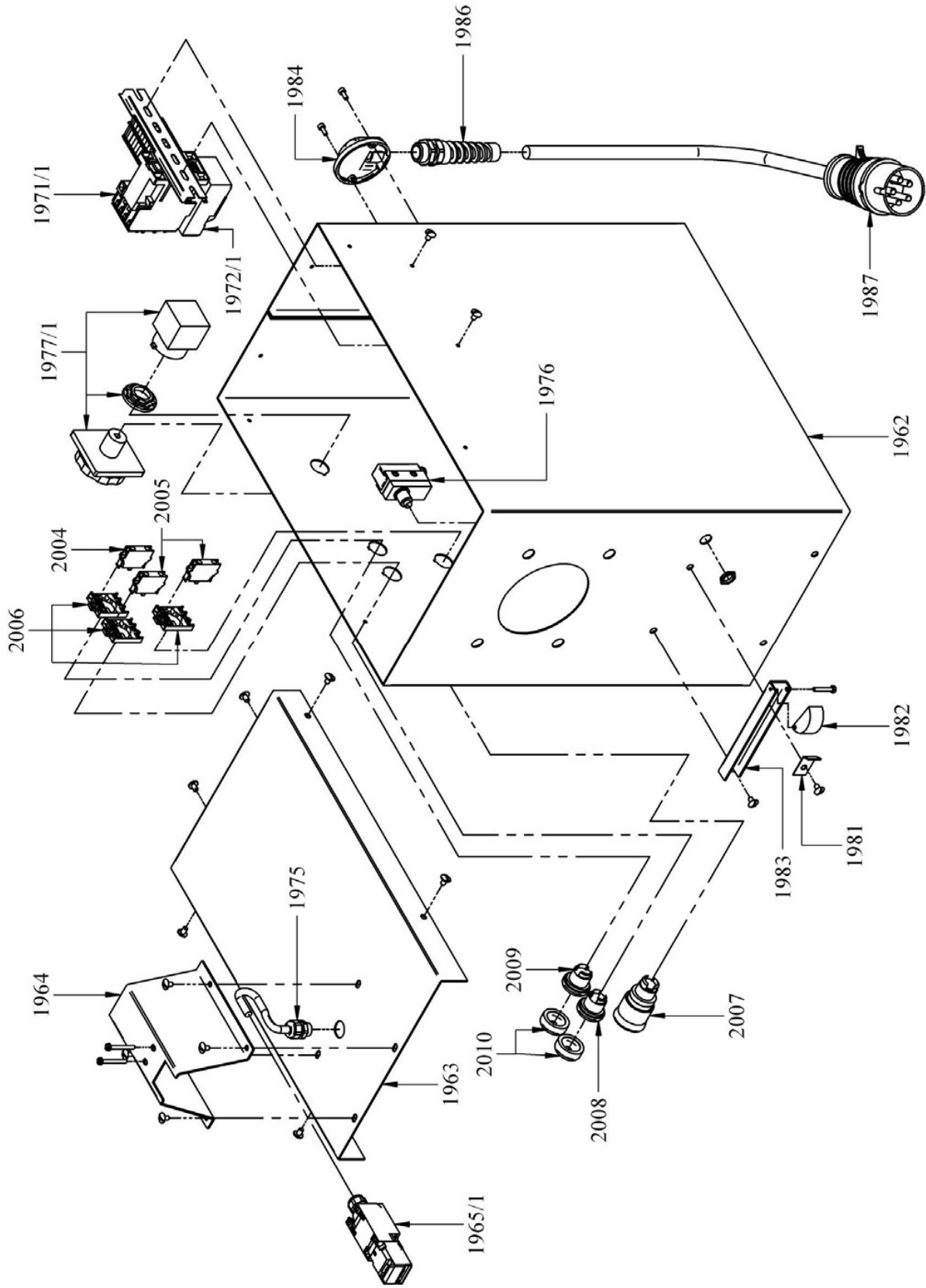

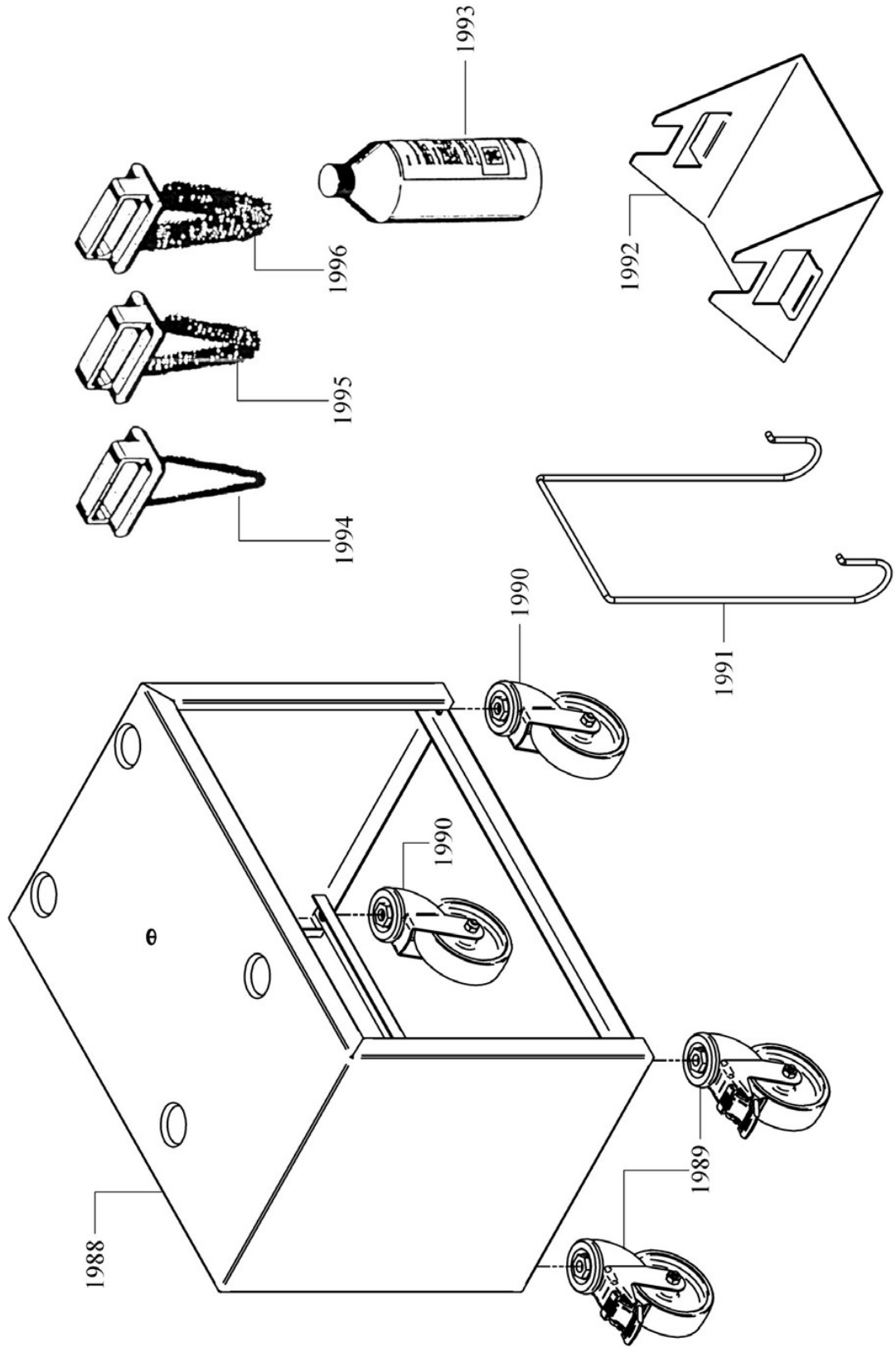

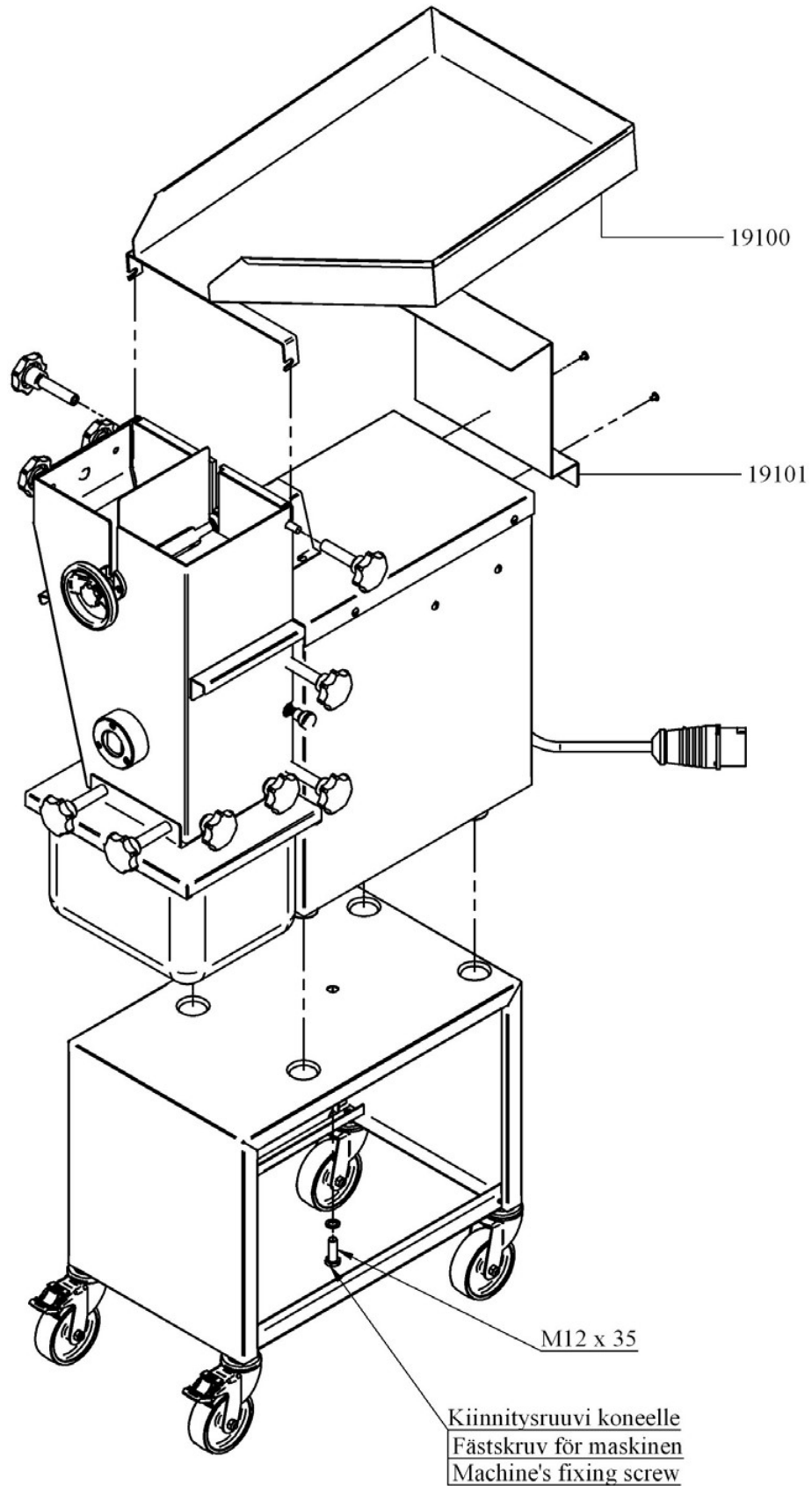

APPENDIX 5 Quantity of the blades and spacers

| SIZE OF BLADE SET | BLADE / PCS |
|-------------------|------------------|
| TERIEN JAKO | TERIEN LKM. /KPL |
| 4 mm | 38 |
| 6 mm | 29 |
| 9 mm | 19 |
| 12 mm | 15 |
| 15 mm | 12 |
| 18 mm | 10 |
| 24 mm | 8 |
| 27 mm | 7 |

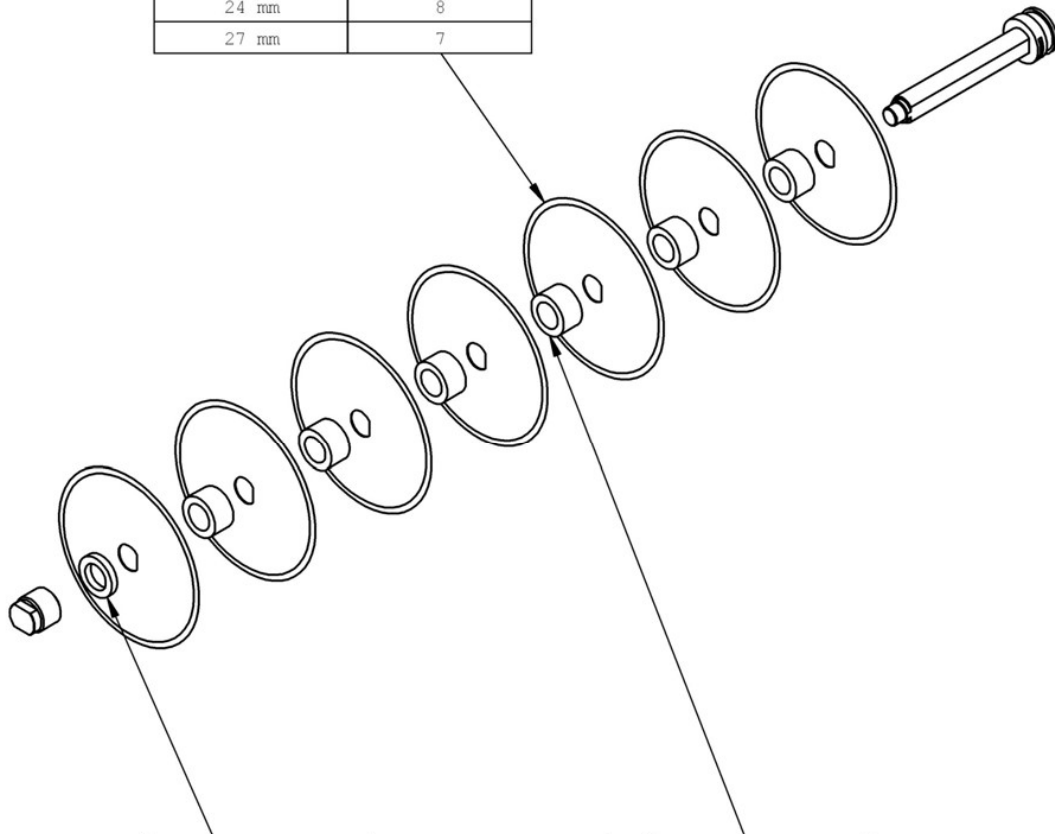

| SIZE OF BLADE SET | SIZE OF BLADE SPACE | BLADE SPACE / PCS |
|-------------------|---------------------|-----------------------|
| TERIEN JAKO | VÄLIRENKAAN PAKSUUS | VÄLIRENKAAN LKM. /KPL |
| 4 mm | 8 mm | 1 |
| 6 mm | 5,5 mm | 1 |
| 9 mm | 8 mm | 1 |
| 12 mm | 5,5 mm | 1 |
| 15 mm | 8 mm | 1 |
| 18 mm | 8 mm | 1 |
| 24 mm | 5,5 mm | 1 |
| 27 mm | 8 mm | 1 |

| SIZE OF BLADE SPACE | BLADE SPACE / PCS |
|---------------------|-----------------------|
| VÄLIRENKAAN PAKSUUS | VÄLIRENKAAN LKM. /KPL |
| 3,3 mm | 37 |
| 4,8 mm | 28 |
| 8 mm | 18 |
| 10,8 mm | 14 |
| 13,8 mm | 11 |
| 17,2 mm | 9 |
| 22,8 mm | 7 |
| 26,4 mm | 6 |