

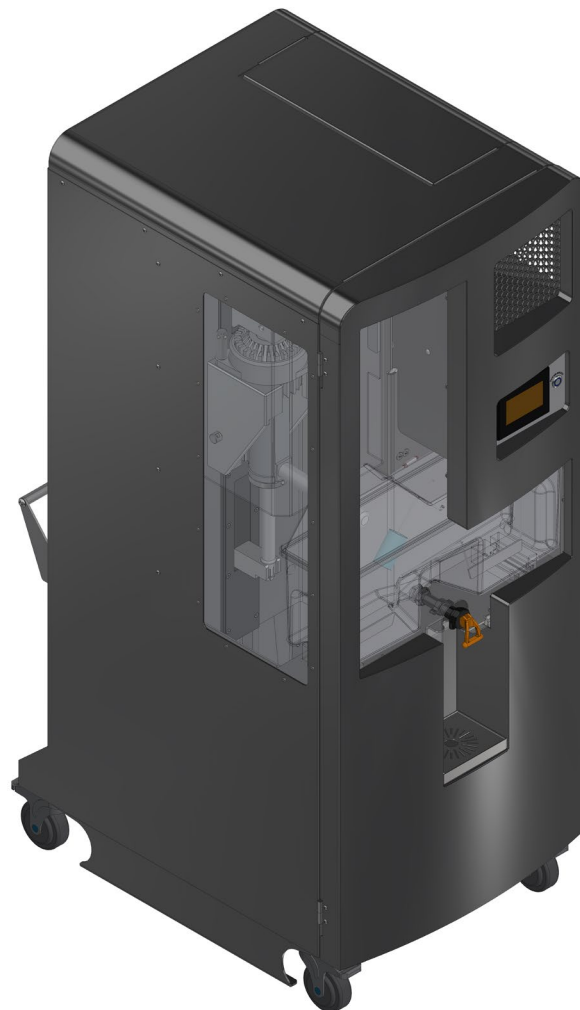

# 2nd Generation Multi-Fruit Juicer

Operator Manual



June 2019



# 2<sup>nd</sup> Generation Multi-Fruit Juicer

## Operator Manual

**Copyright © John Bean Technologies Corporation 2019**

JBT Corporation  
400 Fairway Avenue  
Lakeland, FL 33801  
(863) 683-5411

Manual No. FNS-0012-060-EN



## **Table of Contents**

<b>Important Safety Information .....</b>	<b>4</b>
<b>Specifications .....</b>	<b>6</b>
<b>General Information .....</b>	<b>7</b>
<b>Operating Instructions .....</b>	<b>9</b>
<b>Cleaning Instructions .....</b>	<b>19</b>
<b>Self Service Operating Instructions .....</b>	<b>23</b>
<b>Self Service Cleaning Instructions .....</b>	<b>25</b>
<b>Operator Do's and Don'ts .....</b>	<b>29</b>
<b>Operator Maintenance .....</b>	<b>31</b>
<b>Troubleshooting .....</b>	<b>34</b>
<b>Illustrated Parts Lists .....</b>	<b>37</b>



## Important Safety Information

You can help prevent personal injury and/or property damage.

**Please read this manual carefully before operating the Multi-Fruit Juicer.  
DO NOT attempt any operation until you understand exactly how the machine functions.**

If uncertainty remains after studying this manual, **please contact John Bean Technologies Corporation.**

We're here to help. With proper handling, the JBT Multi-Fruit Juicer will provide safe, efficient and convenient service for years to come.

	<b>North America</b> JBT Corporation 400 Fairway Ave Lakeland, FL 33801 USA Phone: +1 863 683 5411 Fax: +1 863 680 3672	<b>Europe</b> JBT Corporation, S.L. Julián Camarillo 26, 4º 28037 Madrid Spain Phone: +34 91 304 00 45 Fax: +34 91 327 50 03	<b>South Africa</b> JBT (Pty) Ltd. Koper Street Brackenfell Cape Town, South Africa 7560 Phone: +27 21 982 1130 Fax: +27 21 982 1136
	<b>Brazil</b> JBT Máquinas e Equipamentos Industriais Ltda. Av. Eng. Camilo Dinucci 4605 14808-900 Araraquara São Paulo Brazil Phone: +55 16 3301 2000 Fax: +55 16 3332 0565	<b>Latin America</b> JBT Corporation Carr. Mty-Salttillo Km 7—Bodega 4 Colonia Las Mitras Santa Catarina, NL Mexico 66350 Phone: +52 81 81 23 70 55 Fax: +52 81 81 23 70 54	<b>Asia / Pacific</b> JBT (Shanghai) Co. Ltd. Room 3002-3003 Haitong Security Building No. 689 Guangdong Road Shanghai 200001, China Phone: +86 21 6341 1616 Fax: +86 21 6341 0708

[www.jbtcorporation.com](http://www.jbtcorporation.com)

### Revision History

Manual Code	Rev.	Date	Change History
FNS-0012-060	A	06/06/19	Initial release

## Safety Labels

The safety labels shown below appear on the Juice Extractor. Safety labels provide essential instructions on how to avoid possible hazards.

**Please, for your safety: FOLLOW THOSE INSTRUCTIONS AT ALL TIMES.**

Should the Juicer safety labels become damaged or unreadable, contact JBT Corporation for replacement labels.



## Safety Instructions

**Carefully review the following safety instructions. Make them a habit when using the JBT Corporation Multi-Fruit Juicer.**

1. If Juicer continues to run when any access cover is open, the interlock switch is defective. **Turn Juicer off immediately.** Call for service.
2. **NEVER** attempt to make any safety device inoperative.
3. **NEVER** operate or perform maintenance or repair work on the Juicer when taking any kind of drug or sedative, when under the influence of alcohol, or when fatigued.
4. **ALWAYS** check adjustment of all nuts, bolts, and screws after installation, repair, or periodic maintenance.
5. **NEVER** attempt to operate or transport machine if the caster wheels are damaged, do not roll freely, or if front and rear brakes do not lock.



# **Specifications**

## **Technical Specifications**

Fruit size: 2 1/2" to 3 3/4" diameter (6.5 cm to 9.5 cm)	
Oranges — FL:.....	125 to 50 count
Oranges — CA:.....	138 to 48 count
Grapefruit — FL:.....	56 to 48 count
Hopper capacity:.....	80 lb. (2 cartons) (36 kg)
Reservoir capacity:.....	3.5 gal. (1 carton) (13.2 liters)
Waste container capacity:.....	40 lb. of peel (2 cartons) (18 kg)
Three Speeds:.....	25 fruit/minute, 29 fruit/minute, 33 fruit/minute

## **Electrical Specifications**

115V, 60 Hz Single Phase 15 AMP Service on a dedicated circuit  
 10 GA. wire — up to 200 ft. from main breaker panel  
 or  
 220 VAC, 50 Hz / 60Hz Single Phase 16 AMP Service  
 10 GA. wire — up to 200 ft. from main breaker panel

## **Shipping Specifications**

Height:	65.4"	(166 cm)
Width:	26"	(65 cm)
Depth:	35"	(89 cm)
Weight:	711 lbs	(323 kg)

## **Patents**

U.S. Patents - #4905586 and #4922814  
 and Patents Pending

## General Information

The JBT Corporation Juicer is designed to provide years of dependable service. It uses a unique patented design to extract every available amount of juice from the fruit with the least amount of peel oil. The peel is completely separated from the juice and juice sacs before being compressed and strained.

The machine will juice all types of citrus — oranges, grapefruit, lemons, limes, tangerines, etc. — without changing or adjusting parts. In fact, different varieties and sizes of fruit can be juiced to create various fruit juice blends.

Clean-up is simple, requiring disassembly of only five parts. All waste material — peel, membranes, and seeds — is collected in a disposable garbage bag for easy removal and disposal.

The Juice Extractor is solidly built using heavy duty components in all assemblies, including the drive. It is simple to operate and uses a minimal number of parts.

**ALWAYS** follow cleaning and maintenance schedules in this manual to prevent equipment damage and maintain juicer performance.

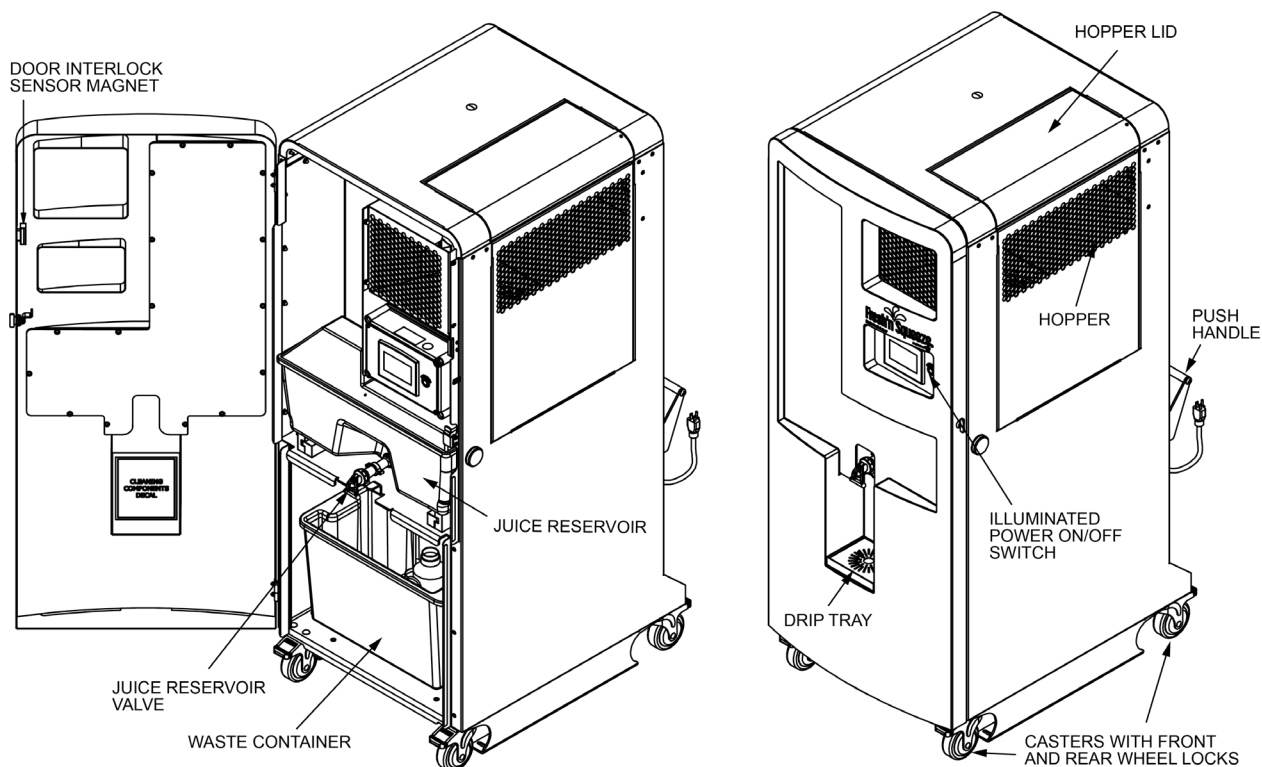

**Figure 1. 2nd Generation Multi-Fruit Juicer**

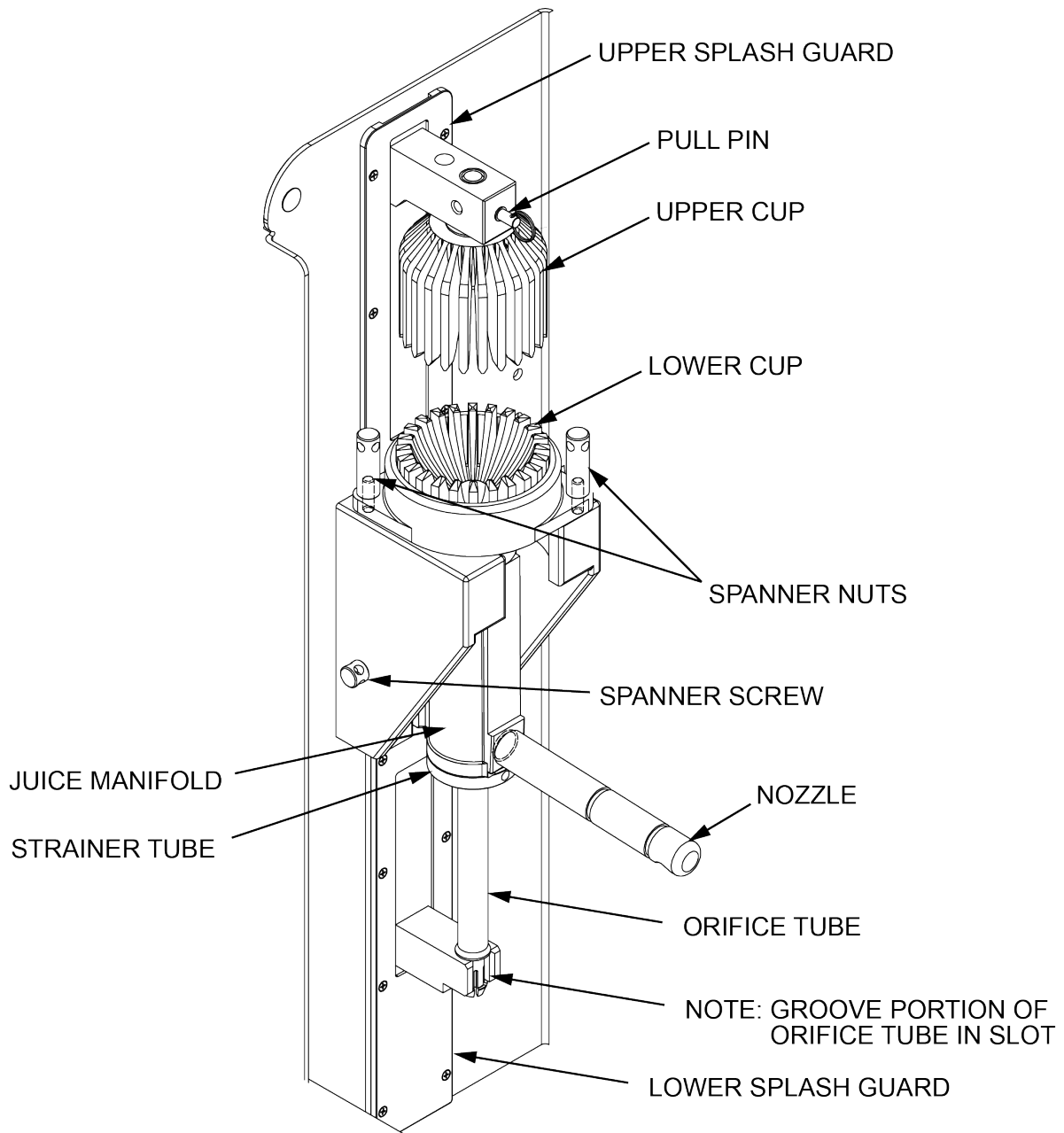

**Figure 2. Juicing Components Assembly**

## Operating Instructions

### Equipment Check

Before plugging the Multi-Fruit Juicer into an electrical outlet, the following steps must be performed:

1. **Locate the Multi-Fruit Juicer on a level surface.**  
This will prevent fruit feed problems.

**CAUTION: WHEN MOVING JUICER, ALWAYS TRANSPORT ON LEVEL SURFACE. USE RAMPS IF NECESSARY. AVOID LEDGES, IRREGULAR FLOORS OR DRAIN INDENTIONS.**

2. **Lock casters.**  
To lock, push down on caster with foot. To unlock, push again with foot.
3. **Check waste container.**  
Open cart door to verify that waste container is in place.
4. **Check juicing components.**  
Remove reservoir, juice nozzle and splash shield, then check juicing components.
5. Make sure juice nozzle is firmly seated. If not present, wet o-ring before installing.
6. Make sure juice reservoir is firmly in place.
7. Close and turn latch to secure door.
8. **Make sure juice reservoir valve is in closed position.**
9. **Check the hopper for foreign objects.**  
Remove any foreign objects found in the hopper.
10. **Make sure floor area around Juicer is clean and free of obstructions and water.**  
Wear appropriate non-slip footwear when water is necessary.



## **Juicing**

- 1. Turn on Juicer.**  
Push the ON-OFF button. Light on button turns on.
- 2. Feed fruit into the Juicer.**
  - a. Open the hopper door.
  - b. Dump carton of fruit into hopper. If necessary, place fruit individually into hopper.
  - c. Close the hopper door.

**CAUTION: TO AVOID PHYSICAL INJURY, USE CAUTION WHEN LIFTING HEAVY WEIGHTS OVERHEAD. IF NECESSARY, DIVIDE FRUIT AND PLACE IN CARTON LID AND DUMP INDIVIDUALLY OR ASK FOR ASSISTANCE WHEN LIFTING OVERHEAD.**

- 3. Initiating and Stopping juicing.**  
See Next Section "Touch Screen Juicer Operation"
- 4. Stir juice.**  
Use stirrer handle located on the side of the machine to stir juice in reservoir before filling containers.
- 5. Fill containers.**  
Place container under juice reservoir valve. Open valve by pulling lever until container is full.
- 6. Clean Juicer.**  
If finished juicing, clean Juicer as soon as possible.  
**(See Page 19 for cleaning instructions.)**

## Touch Screen Juicer Operation

Early models of this juicer used word labels instead of symbols, however, the location of the buttons and their functions remain the same.

### Standard Start Screen

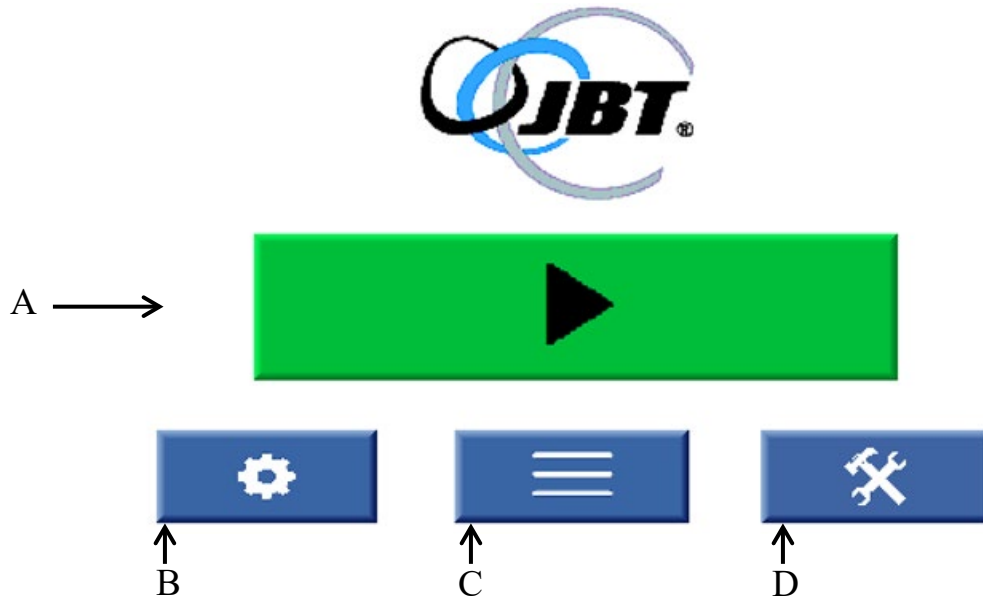

### Self-Service Start Screen

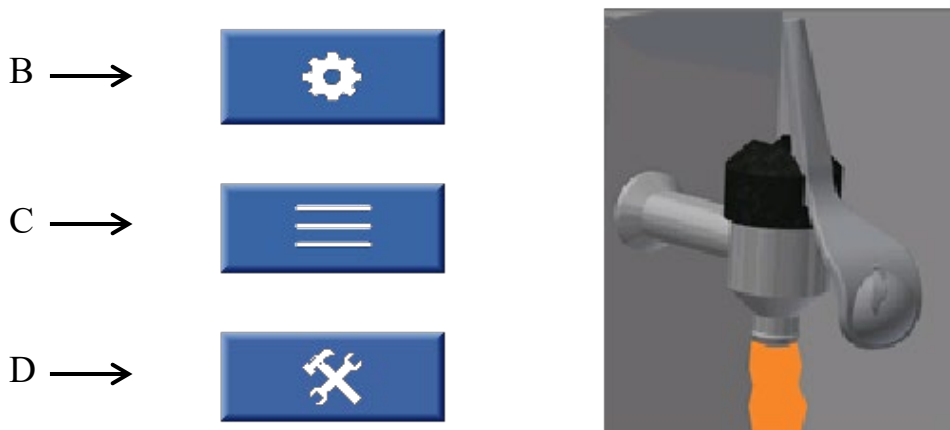

- A. Start Button – Starts Juicing (on self-service machines, pulling down on the handle starts juicing)
- B. Go to Settings – Options to change the juicing speed and the juicing animation screen.
- C. Go to Status – View various information about the unit.
- D. Go to Service – Various settings for the juicer, this is for service personnel only.

## Processing Screens

- These screens appear when the juicer is actively running.
- There are two animations available which can be chosen on the settings page.

# Processing...

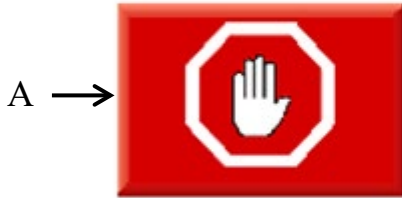

A. Stop Button – Juicer will continue to run until it reaches the point when the cups are farthest apart.

NOTE: In self-service tap mode, the tap handle must be held down for this to function. Once the juicer has stopped, then the handle can be released.

## Juice Tank Full

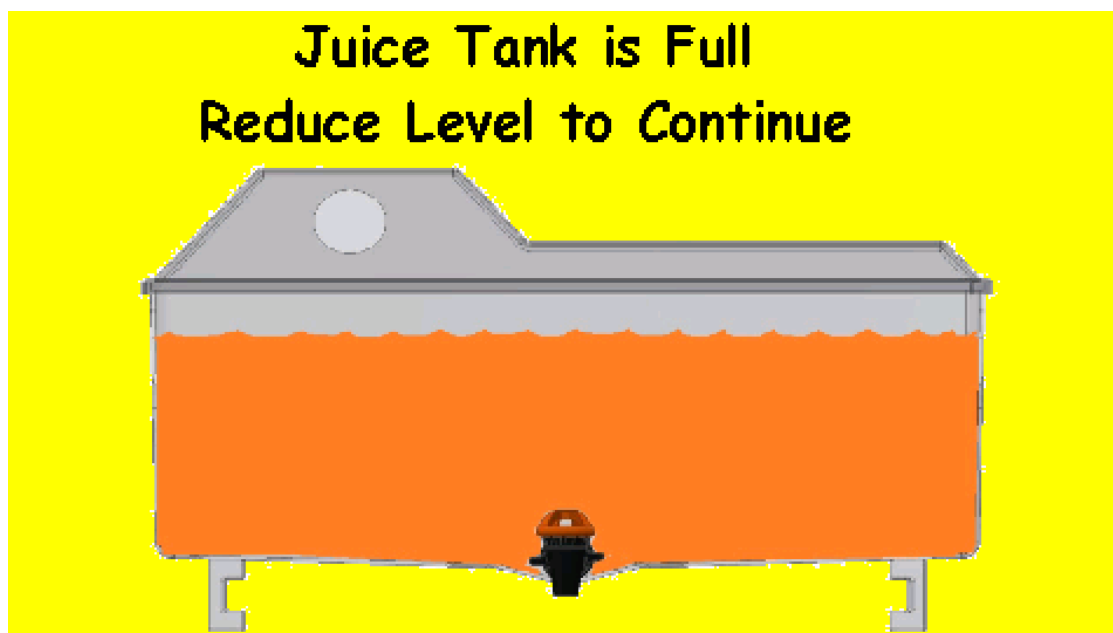

When this screen appears, it indicates that the juice tank is full and the juicer has stopped. The juicer will not run again until juice is removed from the tank.



## Settings Screen

A → **Speed Setting**



**Display Setting** ← B

Filling Glass



Dancing Orange



- A. Speed setting - The juicer can run at 25, 29, or 33 fruit per minute. Be aware that some harder or larger fruit may not process at the higher speeds. If excessive stalling or mis-feeding is observed, switch speed to a lower setting to improve performance.
- B. Display setting – These check boxes choose which animation is displayed while the juicer is running.

## Status Screen

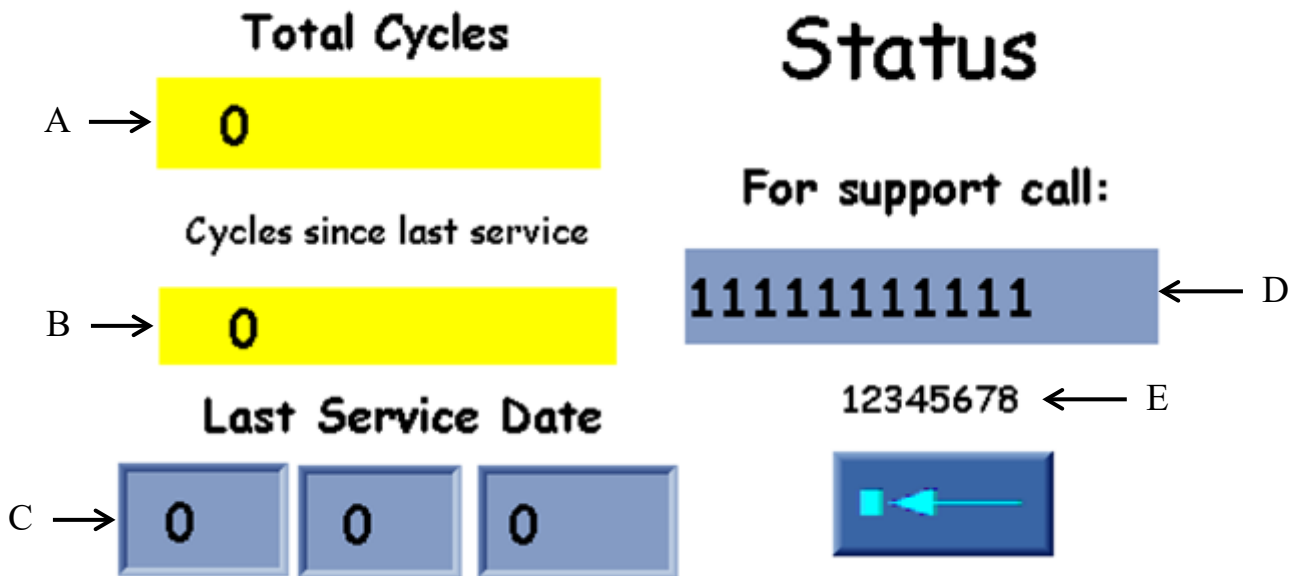

- A. Total Cycles – indicates the total number of cycles the juicer has run.
- B. Cycles since last service – shows how many cycles have run since the last time the juicer was serviced
- C. Last Service Date – shows what the date of the last service was for the juicer. The format for this date is: Month Day Year
- D. Support Phone Number – phone number for the service company for the juicer.
- E. Juicer serial number – serial number for the juicer

## Informational Screens

### Front Door Open

**Warning!**

**Front Door open**

**Close Door before  
Restarting**

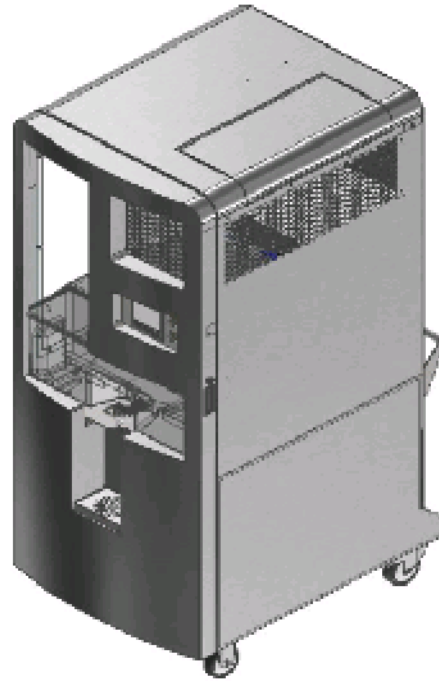

This screen indicates that the front door is not properly closed. The juicer will not run until the door is fully closed

### Hopper Door Open

**Warning!**

**Hopper Door Open**

**Close Door before  
Restarting**

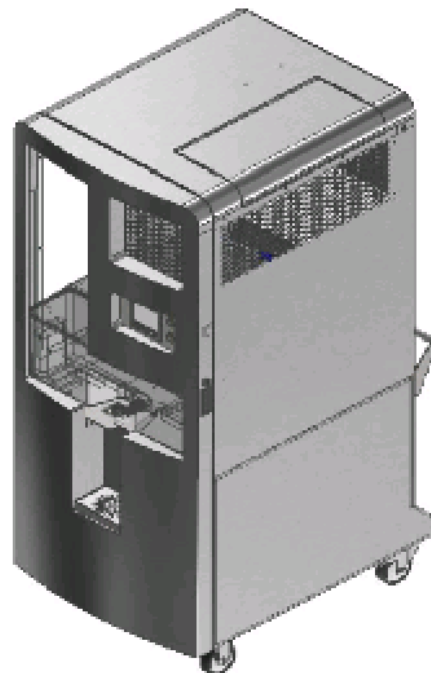

This screen indicates that the hopper door or fruit loading door on top is open. The juicer will not run while this door is open

## Position Sensor Error

**Position sensor not detected  
Please ensure machine  
is operating properly  
Contact service Dept.**



This error message occurs because the juicer is operating, but the position sensor has not been detected. The juicer is still capable of running, but the following features will be disabled or not function properly: speed setting, stop button, cycle counting.

## Motor Fault

**Motor Stall**

**Motor has stalled. Press  
"Restart" to begin running again.  
If the issue persists turn off  
and inspect for blockages.**



If this screen appears it indicates that the motor has stopped. This is usually caused by a blockage, large fruit, hard fruit, frozen fruit, or something else. Press the ( ) button for the juicer to restart. If the error continues, the blockage will need to be removed manually.  
**ALWAYS POWER OFF THE JUICER BEFORE ATTEMPTING TO CLEAR ANY BLOCKAGE.**



## Safety Circuit

# Safety Circuit Fault!

Power off the machine,  
check all cables and restart

If problem persists  
contact service:

18005555555 180

When this message occurs, it indicates that there is a problem with one of the safety sensors. The juicer will not run until the problem has been fixed.

## Battery Warning

# Attention! Battery Low

If battery dies this  
machine may not run.

Contact Service Department



If this error message occurs, it indicates that the battery in the touch screen is running low. As the message states, if the battery dies completely the machine may not run at all. Touch the blue button to confirm to continue juicing and contact the local service provider to have the battery replaced as soon as possible.

## Cleaning Instructions

**ALWAYS follow cleaning and maintenance schedules in this manual to prevent equipment damage.**

Clean Juicer as soon as possible after juicing. Use a soft towel or sponge to wipe equipment parts. **DO NOT** use abrasive pads such as green scrub pads or steel wool.

The recommended cleaner is JBT Corporation brand CorKlean. CorKlean is a low-foaming alkaline equipment cleaner. It is safe on aluminum, 100% water soluble and free rinsing. CorKlean has been especially formulated for cleaning food processing equipment and is USDA accepted. Follow instructions on cleaner label for dilution.

1. **Turn-off Juicer using the STOP button on the touch screen to ensure maximum separation between upper and lower cups. Refer to the “Touch Screen Juicer Operation” section of this manual.**
2. **DISCONNECT ELECTRICAL PLUG.**

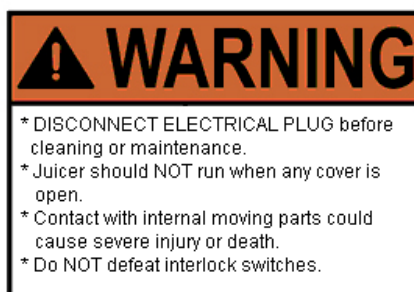

3. **Pull Juicer to clean-up area, if one is available.**



4. **Brush all loose peel into waste container or bag.**
5. **Empty and rinse waste container.**



**6. Remove juicing components (see Figure 6).**

- a. Cups should be separated. (Juicer should have been turned off using the STOP button on the touch screen, see Step 1.)
- b. Remove reservoir and juice nozzle, then lift splash shield off mounting brackets.

**CAUTION: DO NOT PLACE HANDS OR FINGERS BETWEEN CUPS.**

- c. Grasp upper cup and pull out pin just above it. Place upper cup in waste container.
- d. Using spanner tool and starting at bottom, loosen the strainer tube in manifold, manifold spanner screw and the spanner nuts securing the lower cup.

**CAUTION: CUTTER AND KNIVES ARE SHARP.**

- e. Install red protective cap on cutter. (Red protective cap is provided.)
- f. Grasp juice manifold and orifice tube firmly. Remove entire juicing components assembly.
- g. Grasp orifice tube and pull out of strainer tube.
- h. Remove strainer tube from inside juice manifold by turning tube counter-clockwise and sliding out. (Spanner wrench is provided to loosen/tighten strainer tube.) Place juicing components into waste container.

**7. Prepare cleaning solution.**

Read the product label on Cleaning Solution and follow the manufacturer's mixing directions and safety precautions.

**8. Immerse all components in cleaning solution.**

Use the blunt end of plastic rod provided to displace any fruit material lodged in the bore of the orifice tube.

Use pointed end of plastic rod to displace any fruit material lodged in cup fingers.

**9. Scrub components.**

Use a brush, towel, or sponge. **DO NOT** use abrasive pads such as steel wool. Thoroughly rinse with clean water, then thoroughly rinse with sanitizer solution. Follow the manufacturer's mixing directions and safety precautions.

**10. For best results, soak strainer tube overnight.**

After soaking overnight, rinse the strainer tube thoroughly before using. Check that all strainer tube holes are clean. Clean strainer tube with a hard spray from a hose while moving orifice tube back and forth in strainer tube. Rinse thoroughly with sanitizer solution. Allow to air dry.

## **Cleaning Instructions (continued)**

### **11. If possible, hose down juicing area and cover.**

If location prohibits using a hose to clean juicing area and cover, ensure waste container is in place. Wash down the exposed juicing area and cover with a sponge or spray applicator using the recommended cleaning solution. Cover may be rinsed in place or removed by lifting it off the hinges. Allow to stand for two minutes before rinsing thoroughly with water.

### **12. Re-assemble juicing components.**

Start by re-assembling strainer tube into juice manifold. Tighten with spanner wrench. Insert orifice tube into bottom of strainer tube. Mount juice manifold assembly onto locating pins with orifice tube notch engaging lower drive. Tighten spanner screw with spanner wrench. Remove red protective cap from cutter. Install lower cup and tighten spanner nuts with spanner wrench. Install upper cup by slipping pin into stem hole. Install splatter shield.

**Refer to Figure 6.**

### **13. Verify that orifice tube is properly installed (Figure 7).**

### **14. Remove wax build-up as needed.**

Cups, hopper and other parts may acquire a build-up of wax over time.

- a. Soak cups for five minutes in Veggie Wash solution to remove wax.**
- b. Use Veggie Wash solution to remove wax from hopper and other areas to remove wax build-up.**

### **15. Remove orange discoloration as needed.**

Equipment may exhibit some build-up or orange coloration over time. Wipe with a cloth soaked in any pine based cleaner to remove discoloration from plastic covers.

Rinse thoroughly with sanitizer solution.

### **16. Clean juice reservoir faucet.**

Daily cleaning is crucial to the performance, maintenance and sanitation of the faucet.

Take apart handle assembly and flush with clean water, then sanitize.

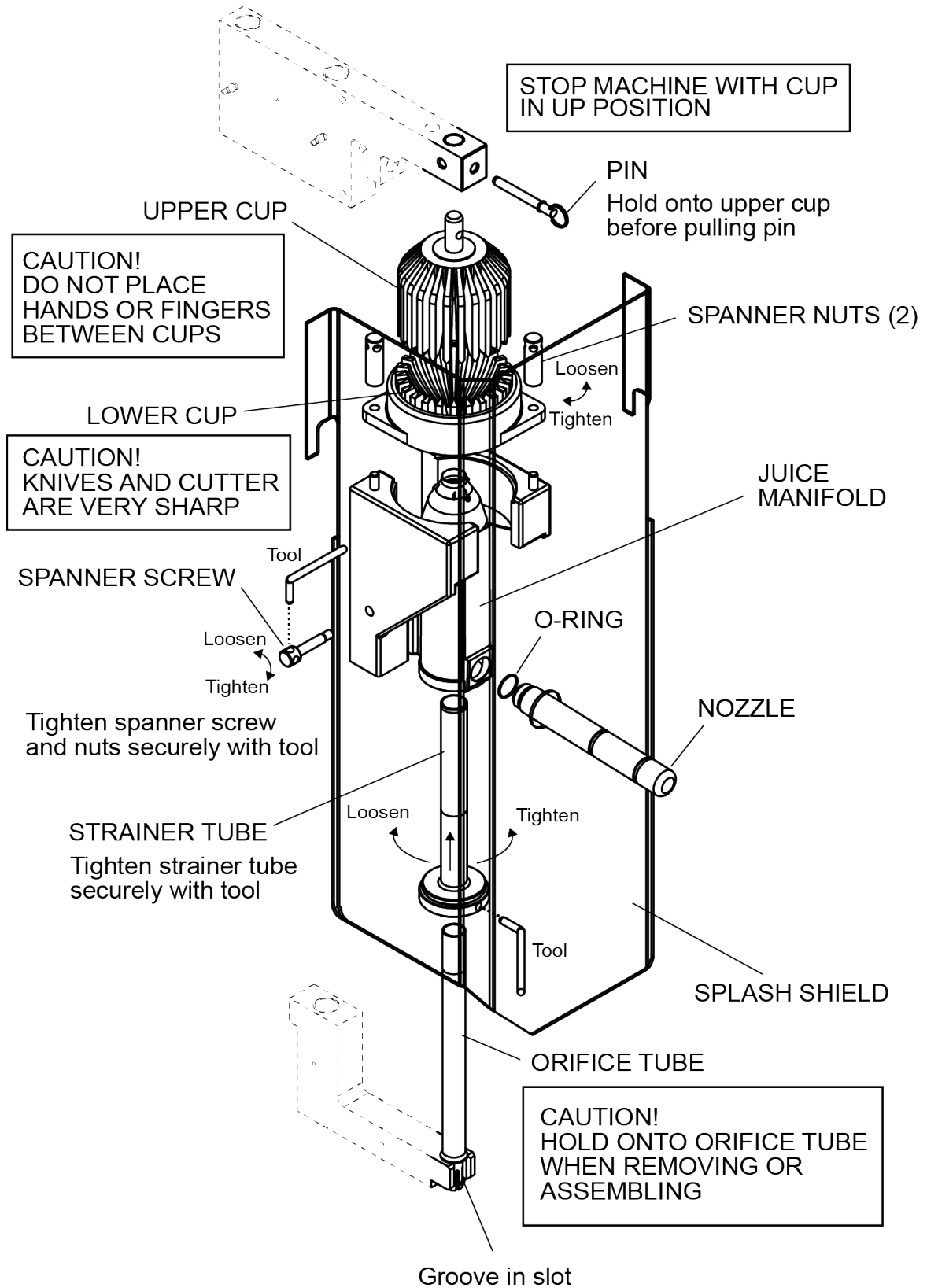

**Figure 6. Removing/Replacing Juicing Components**



## **Self-Service Option Operating Instructions**

### **Equipment Check**

**Before plugging the Multi-Fruit Juicer into an electrical outlet, the following steps must be performed:**

**1. Locate the Multi-Fruit Juicer on a level surface.**

This will prevent fruit feed problems.

**CAUTION: WHEN MOVING JUICER, ALWAYS TRANSPORT ON LEVEL SURFACE. USE RAMPS IF NECESSARY. AVOID LEDGES, IRREGULAR FLOORS OR DRAIN INDENTIONS.**

**2. Lock casters.**

To lock, push down on caster with foot. To unlock, push again with foot.

**3. Check waste container.**

Open cart door to verify that waste container is in place.

**4. Check juicing components.**

Remove self-service assembly and splash shield, and then check juicing components.

**5. Check Self-Service Assembly.**

Make sure self-service assembly is fully inserted under the two retaining posts and the spout nozzle is firmly seated in the manifold. If not present, wet O-ring before installing.

**6. Close and turn latch to secure door.**

**7. Make sure self-service valve handle is released and in the off/closed position.**

**8. Check the hopper for foreign objects.**

Remove any foreign objects found in the hopper.

**9. Make sure floor area around Juicer is clean and free of obstructions and water.**

Wear appropriate non-slip footwear when water is necessary.



## **Juicing**

### **1. Turn on Juicer.**

Push the ON-OFF button. Circle on button will illuminate.

### **2. Feed fruit into the Juicer.**

- a. Open the hopper door.
- b. Dispense carton of fruit into hopper. If necessary, place fruit individually into hopper.
- c. Close the hopper door.

**CAUTION: TO AVOID PHYSICAL INJURY, USE CAUTION WHEN LIFTING HEAVY WEIGHTS OVERHEAD. IF NECESSARY, DIVIDE FRUIT AND PLACE IN CARTON LID AND DISPENSE INDIVIDUALLY OR ASK FOR ASSISTANCE WHEN LIFTING OVERHEAD.**

### **3. Place juice container.**

Center juice container opening under self-service spout nozzle.

### **4. Initiate juicing.**

Pull self-service handle downward to start juicing. Depending on the type of handle installed constant pressure may be required to sustain juicing operation. If equipped with a constant dispense handle, pulling the handle all the way down will lock the handle and juicing will continue until the handle is lifted.

### **5. Stop juicing.**

Lift the self-service handle to stop juicing at any point.

### **6. Topping off juice containers.**

The handle may be actuated repeatedly for short durations to top off juice container.

### **7. Clean Juicer.**

If finished juicing, clean Juicer as soon as possible.  
**(See Next Page for cleaning instructions.)**

## Self-Service Option Cleaning Instructions

**ALWAYS** follow cleaning and maintenance schedules in this manual to prevent equipment damage.

Clean Juicer as soon as possible after juicing. Use a soft towel or sponge to wipe equipment parts. **DO NOT** use abrasive pads such as green scrub pads or steel wool.

The recommended cleaner is JBT Corporation brand CorKlean. CorKlean is a low-foaming alkaline equipment cleaner. It is safe on aluminum, 100% water soluble and free rinsing. CorKlean has been especially formulated for cleaning food processing equipment and is USDA accepted. Follow instructions on cleaner label for dilution.

**1. Actuate the self-service handle until there is a maximum separation between upper and lower cups. Then press ON/OFF button to power off juicer.**

**2. DISCONNECT ELECTRICAL PLUG.**

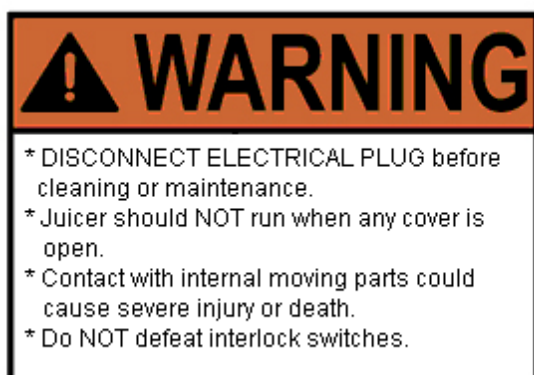

**3. Pull Juicer to clean-up area, if one is available.**



**4. Brush all loose peel into waste container or bag.**

**5. Empty and rinse waste container.**



## **6. Remove juicing components (see Figure 1).**

- a. Cups should be separated. (Juicer should have been turned off with maximum separation between cups using the method described in Step 1.)
- b. Remove self-service spout housing assembly by grasping either side of the housing and pulling straight out, then lift splash shield off mounting brackets.

**CAUTION: DO NOT PLACE HANDS OR FINGERS BETWEEN CUPS.**

- c. Grasp upper cup and pull out pin just above it. Place upper cup in waste container.
- d. Using spanner tool and starting at bottom, loosen the strainer tube in manifold, manifold spanner screw and the spanner nuts securing the lower cup.

**CAUTION: CUTTER AND KNIVES ARE SHARP.**

- e. Install red protective cap on cutter.  
(Red protective cap is provided.)
- f. Grasp juice manifold and orifice tube firmly. Remove entire juicing components assembly.
- g. Grasp orifice tube and pull out of strainer tube.
- h. Remove strainer tube from inside juice manifold by turning tube counter-clockwise and sliding out.  
(Spanner wrench is provided to loosen/tighten strainer tube.)  
Place juicing components into waste container.

## **7. Prepare cleaning solution.**

JBT Corporation brand CorKlean is recommended, see Operator Manual Page 19. Read the product label. Follow the manufacturer's mixing directions and safety precautions.

## **8. Immerse all components in cleaning solution.**

Use the blunt end of plastic rod provided to displace any fruit material lodged in the bore of the orifice tube.

Use pointed end of plastic rod to displace any fruit material lodged in cup fingers.

## **9. Scrub components.**

Use a brush, towel, or sponge. **DO NOT** use abrasive pads such as steel wool. Thoroughly rinse with clean water, then thoroughly rinse with sanitizer solution. Follow the manufacturer's mixing directions and safety precautions.

## **10. For best results, soak strainer tube overnight.**

After soaking overnight, rinse the strainer tube thoroughly before using. Check that all strainer tube holes are clean. Clean strainer tube with a hard spray from a hose while moving orifice tube back and forth in strainer tube. Rinse thoroughly with sanitizer solution. Allow to air dry.

## **Self Service Option Cleaning Instructions (continued)**

### **11. If possible, hose down juicing area and cover.**

If location prohibits using a hose to clean juicing area and cover, ensure waste container is in place. Wash down the exposed juicing area and cover with a sponge or spray applicator using the recommended cleaning solution. Cover may be rinsed in place or removed by lifting it off the hinges. Allow to stand for two minutes before rinsing thoroughly with water.

### **12. Re-assemble juicing components.**

Start by re-assembling strainer tube into juice manifold. Tighten with spanner wrench. Insert orifice tube into bottom of strainer tube. Mount juice manifold assembly onto locating pins with orifice tube notch engaging lower drive. Tighten spanner screw with spanner wrench. Remove red protective cap from cutter. Install lower cup and tighten spanner nuts with spanner wrench. Install upper cup by slipping pin into stem hole. Install splatter shield.

**Refer to Figure 1.**

### **13. Verify that orifice tube is properly installed (Figure 2).**

### **14. Remove wax build-up as needed.**

Cups, hopper and other parts may acquire a build-up of wax over time.

- a. Soak cups for five minutes in Veggie Wash solution to remove wax.
- b. Use Veggie Wash solution to remove wax from hopper and other areas to remove wax build-up.

### **15. Remove orange discoloration as needed.**

Equipment may exhibit some build-up or orange coloration over time. CorKlean solution should remove this. Wipe with a cloth soaked in any pine based cleaner to remove discoloration from plastic covers.

Rinse thoroughly with sanitizer solution.

### **16. Clean self-service housing and spout.**

Daily cleaning is crucial to the performance, maintenance and sanitation of the self-service assembly. After the self-service assembly is removed from the machine, remove the spout cap assembly by rotating it counter clockwise 1/4 turn and then lifting the entire assembly from the spout body. Depress the seal plug and remove the handle to disassemble. Rinse cap, spring, stem and seal plug with clean water and sanitize. Rinse housing and flush spout body with clean water and sanitize. Note that removal of the spout nozzle from the housing is not required for proper cleaning.

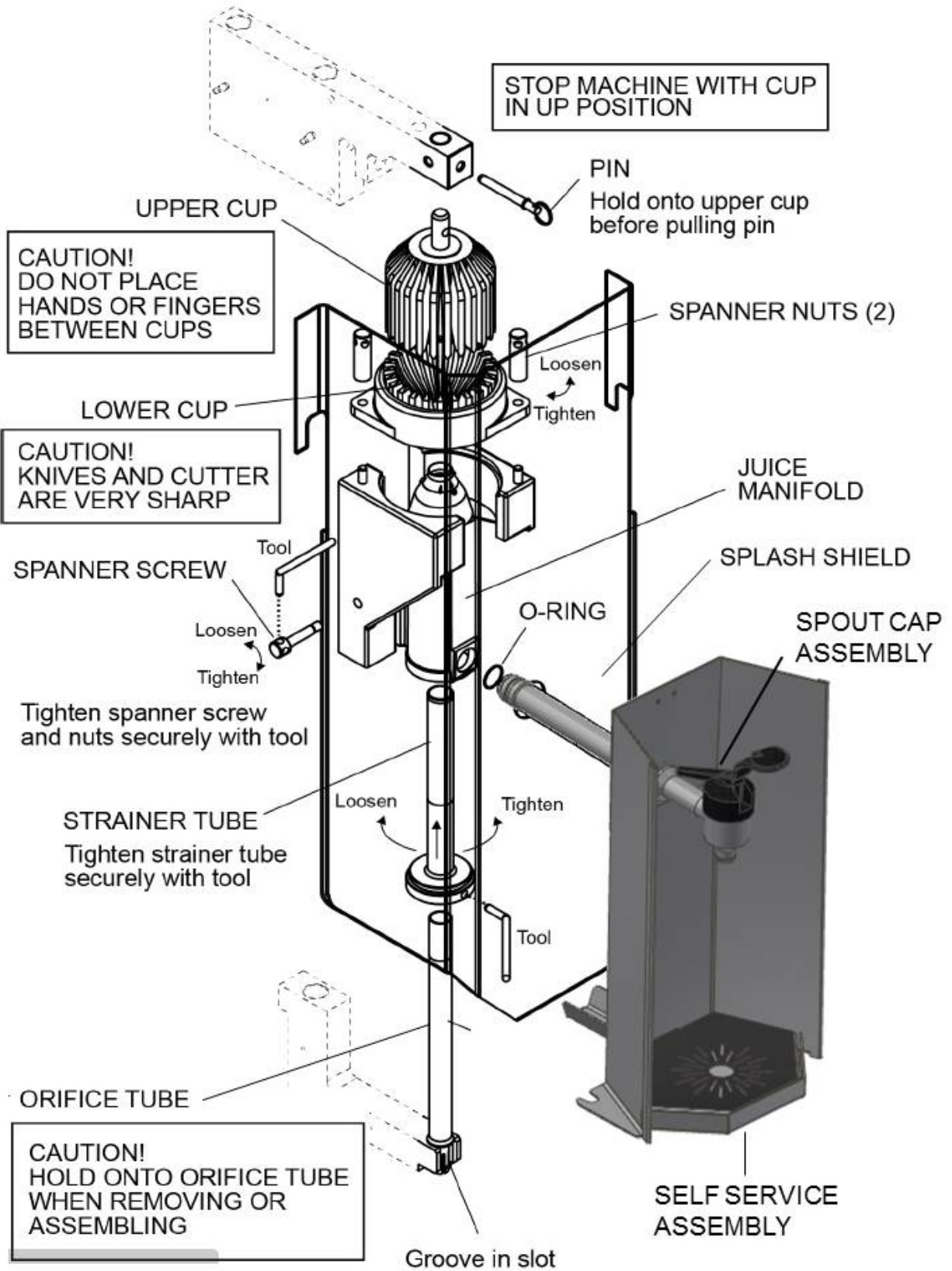

**Figure 1. Removing/Replacing Self-Service Juicing Components**



## Operator Do's and Don'ts

Do's	Don'ts
Unplug juicer before removing splash shields or panels	DO NOT remove juicing components or panels before unplugging
Use light water spray when rinsing juicer	DO NOT use high pressure or volume water when rinsing juicer
Wipe off touch screen and electrical connections with damp cloth when cleaning	DO NOT spray water with hose to clean touch screen or electrical connections
Stop juicer with cups in most open position	DO NOT stop cups in closed position
If fruit doesn't roll in hopper, remove wax build-up from inside using spray bottle and damp towel	DO NOT use food grade non-stick product inside of the hopper
Use spray bottle with cleaner on main frame in juicing components area	DO NOT use chemical dosage and water system to clean main casting (can result in mechanical damage)
Rinse sanitizer off juicer five minutes after applying	DO NOT leave sanitizer on juicer without rinsing (can damage or discolor aluminum parts and casting)
Use fruit within size range (2-1/4" to 3-7/8" diameter). Use fruit template to measure fruit	DO NOT use oversized fruit or undersized fruit with diameter less than 2-1/4" (undersized fruit can result in double feed and cause cups to break, as well as loss of yield and off flavor)
Inspect and test front door and hopper lid safety switches weekly	DO NOT use juicer if safety switches are not working properly
Install juicing components using spanner tool; tighten spanner nuts from top to bottom	DO NOT hand tighten spanner nuts and screw (can result in major equipment damage)
Install orifice tube into slot on lower arm (see Figure 7 on Page 30)	DO NOT install orifice tube on top of lower arm slot (see Figure 7 on Page 30)
Inspect cutter daily. Replace if damaged; adjust and tighten screw	DO NOT continue to juice fruit with cutter damaged, loose or dull
If fruit is bursting in cups, inspect fruit for cuts, fruit too large, cutter/orifice tube damaged or strainer tube holes plugged	DO NOT continue to juice fruit with fruit bursting in cups
If yield loss is noticed, check for orifice discharge pushing out cutter and waste wet, the timing can be off (call for service tech)	DO NOT continue to juice with fruit condition causing problem
Mix juice and pulp slowly to reduce foam in reservoir	DO NOT mix juice quickly in reservoir (can result in foam and off flavor)
If foam is dark orange color in reservoir and has off flavor, cutter is likely damaged, loose or dull (tighten, sharpen or replace)	DO NOT continue to juice fruit with cutter damaged, loose or dull
If the juicer stalls, it will attempt to squeeze the fruit 3 times, if the fruit can't be squeezed, juicer will shut off. Check for oversized, hard or multiple fruit in cup. Unplug juicer and remove objects from cups	DO NOT continue to squeeze fruit without determining cause of stalled juicer

## ORIFICE TUBE INSTALLATION



CORRECT ✓

GROOVE OF ORIFICE TUBE  
INSTALLED IN LOWER ARM SLOT

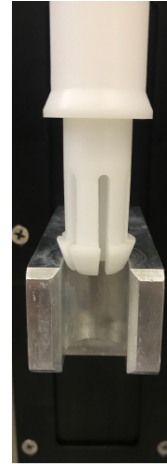

INCORRECT ✗

ORIFICE TUBE INSTALLED  
ON TOP OF LOWER ARM SLOT

## RESULTS OF IMPROPER ORIFICE TUBE INSTALLATION



DAMAGED ORIFICE TUBE  
AND CUTTER



ORIFICE TUBE BROKEN OFF  
INSIDE UPPER CUP



ORIFICE TUBE DOES NOT  
CLEAN STRAINER TUBE  
(EFFECTS JUICE YIELD  
AND QUALITY)

**Figure 7. Proper Orifice Tube Installation**

## Operator Maintenance

Before performing any maintenance,

**DISCONNECT ELECTRICAL PLUG.**

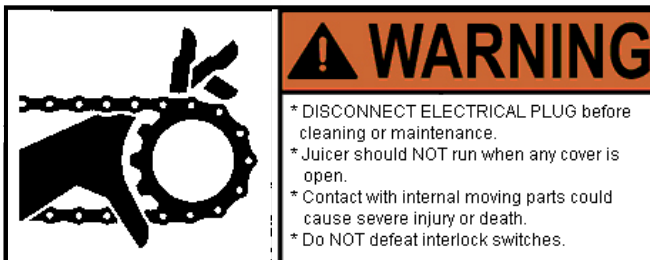

**LOCK FRONT AND REAR CASTER WHEELS.**

After every juice run:

1. **Check cutter and knives for sharpness.**

Refer to **Figure 8** to determine condition of cutter.

If dull, sharpen with a whetstone provided.

Refer to **Figure 8** to sharpen cutter.

If cutter is severely damaged or rolled over, replace cutter.

a. **Cutter removal:**

Disassemble juicing components (Figure 6, Page 22). Loosen set screw under front knife (make sure screw is backed out far enough to clear cutter). Cutter should lift out, if not, tap the cutter lightly from inside the juice manifold with a 1-1/4" diameter rod (hammer handle).

**CAUTION: CUTTER AND KNIVES ARE SHARP.**

Install red protective cap provided onto cutter. After red protective cap is installed, remove cutter. Handle cutter with care to avoid direct contact with sharp edge.

b. **Cutter installation:**

Align arrows on cutter and juice manifold to seat cutter. Make sure cutter is fully seated. Tighten set screw. (**DO NOT** over-tighten.)

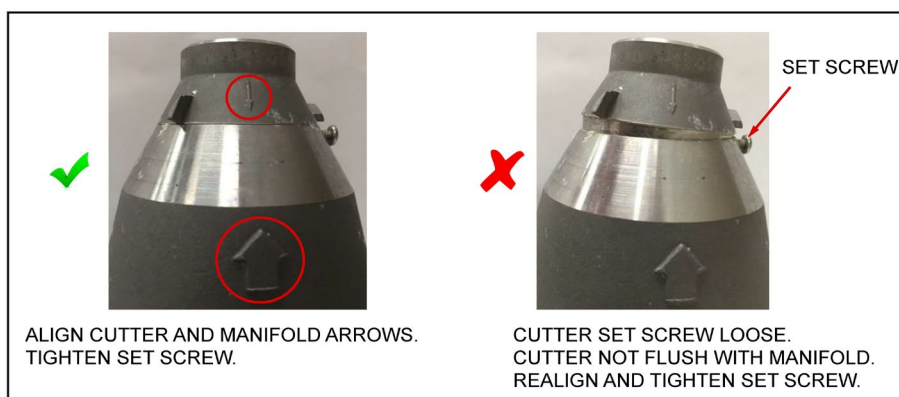

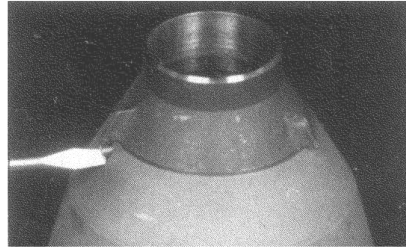

INSTALLATION OF  
GOOD CUTTER

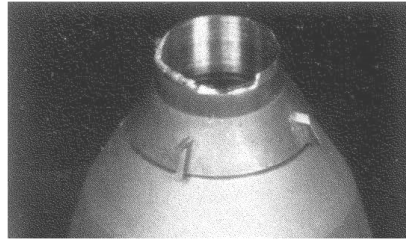

BAD CUTTER  
REPLACE CUTTER

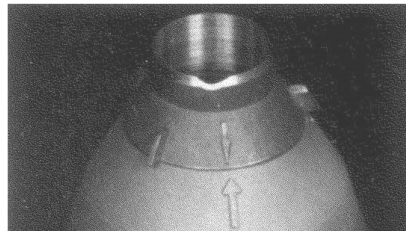

CUTTER THAT  
CAN BE SHARPENED



SHARPENING CUTTER  
WITH WHETSTONE



SHARPENING KNIFE  
WITH WHETSTONE

**Figure 8. Sharpening Cutter**

## **Operator Maintenance (continued)**

- 2. Check orifice tube for damage.**  
Refer to Figure 9.

Replace tube when:

- a. Chunks are missing from top end.
- b. Score marks 1/32" or deeper appear along the length of the tube.

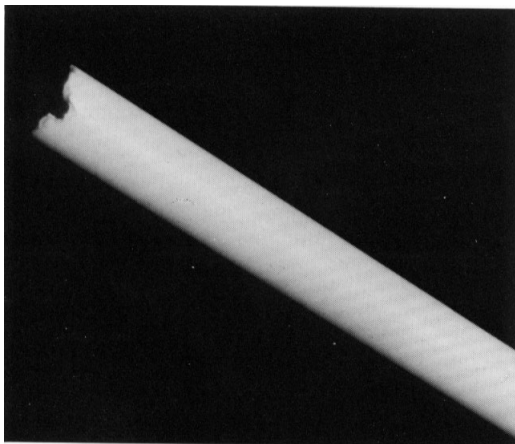

**Figure 9. Severely Damaged Orifice Tube**

- 3. Check for loose or missing nuts and bolts.**
  - a. Tighten or replace nuts and bolts as necessary.
  - b. **DO NOT** exceed torque ranges specified.
  - c. **ALWAYS** use JBT Corporation recommended spare parts.

### **Periodic Inspection**

**Perform the following steps every week.**

- 1. Test all access cover interlock switches.**

Juicer should stop automatically when any access cover is opened. Individually open and close the front door and hopper access door.

If juicer continues to run when front door or hopper access is opened, the interlock switch is defective. Stop the juicer and call service provider immediately.

**See Troubleshooting Section.**
- 2. Inspect casters for damage or wear.**

Caster must roll freely and front and rear brakes must lock.



## Troubleshooting

Condition	Corrective Action
Juicer will not run	<ul style="list-style-type: none"> <li>• Reset breaker</li> <li>• Power cord plugged in?</li> <li>• Doors and covers closed and locked?</li> </ul>
Orifice tube stuck in strainer tube	<ul style="list-style-type: none"> <li>• Orifice tube installed incorrectly</li> <li>• Excess pulp in strainer, thoroughly clean out pulp from strainer</li> <li>• Top of orifice tube damaged</li> <li>• Strainer tube damaged or bent</li> </ul>
Peel and seeds in juice	<ul style="list-style-type: none"> <li>• Cutter missing or loose</li> <li>• Strainer tube not tight in manifold</li> <li>• Top of strainer tube damaged</li> </ul>
Foam in reservoir	<ul style="list-style-type: none"> <li>• Cutter damaged</li> <li>• Mixing juice and pulp too fast causes air to mix in juice</li> </ul>
Fruit bursting and waste is wet	<ul style="list-style-type: none"> <li>• Fruit is too large (3-7/8" max)</li> <li>• Check for damaged fruit</li> </ul>
Juice in waste and/or discharge is wet	<ul style="list-style-type: none"> <li>• Check for damaged fruit</li> <li>• Inspect orifice tube top for damage or wear</li> <li>• Strainer tube holes are plugged</li> <li>• Fruit too large</li> </ul>
Juice nozzle leaking juice	<ul style="list-style-type: none"> <li>• Nozzle O-ring missing or damaged; replace O-ring</li> </ul>
Fruit not feeding out of hopper into cup	<ul style="list-style-type: none"> <li>• Remove wax build-up in hopper</li> <li>• Wipe with food grade non-stick product inside hopper</li> </ul>
Cutter damaged and has rolled top edge	<ul style="list-style-type: none"> <li>• Dried peel, stems stuck in upper cup cutter</li> <li>• Broken top edge of orifice tube wedged inside cutter</li> <li>• Clean out obstruction</li> </ul>
Juicer stalls and shuts off	<ul style="list-style-type: none"> <li>• Cutter dull</li> <li>• Fruit too large</li> <li>• Orifice tube damaged</li> <li>• Strainer tube needs cleaning</li> </ul>
Juicer runs then shuts off	<ul style="list-style-type: none"> <li>• Check door safety switches, locks and reservoir high level switch</li> </ul>
Juice yield less than 2-1/2 gallons per case	<ul style="list-style-type: none"> <li>• Fruit soft or too large</li> <li>• Orifice tube, strainer tube and/or cutter damaged; replace damaged parts</li> </ul>
Clear plastic window of juice reservoir scratched	<ul style="list-style-type: none"> <li>• Do not use scrub pads on any plastic parts</li> </ul>

## **Troubleshooting (continued)**

- **Juicer will not start**

1. **Juicer is not plugged into electrical outlet.**
2. **Building circuit breaker or GFI has tripped (reset).**
3. **Covers are not completely closed.**

Open and close both doors, make sure the sensors are securely fastened and then ensure the doors are firmly closed.

- **Juicer starts, but shuts off**

1. **Juicer is tripping GFCI outlet**

Certain GFCI outlets will not support the juicer. Have electrician replace with a compatible outlet.

2. **Building circuit breaker is not properly rated for 15 Amps.**

3. **Extension cord or wiring is too long.**

Shorten extension cord or use heavier gauge wire. (See Page 6 "Electrical Specifications")

4. **All covers not completely closed (including cart).**

Juicer may be flexing when squeezing fruit, causing switch to open. Make sure all latches are completely locked.

- **Safety Circuit Fault screen will not go away**

1. **Call Service Provider**



## Troubleshooting (continued)

- **Juicer stalls trying to squeeze fruit**

1. **Fruit has part of stem on it.**

Turn off Juicer and unplug . Remove fruit from the Juicer and restart.

2. **Peel is too thick.**

Turn off Juicer and unplug. Remove fruit from the Juicer and restart.

3. **Juicer is operating too quickly.**

Use a lower speed setting on the settings page.

4. Turn off Juicer and unplug . Remove fruit from the Juicer and restart.

5. **Cutter is damaged.**

**CAUTION: CUTTER AND KNIVES ARE SHARP.**

- a. Sharpen or replace cutter as specified in Maintenance section.

- b. Install red protective cap onto cutter.

- c. After red protective cap is installed, remove cutter. Handle cutter with care to avoid contact with sharp edge.

- **Juicer runs with covers open or off**

**Power off and unplug juicer immediately and call service provider**

- **Juicer emits "squealing" sound during operation**

**Spray food grade lubricant on all rotating parts.**

If noise continues, call service provider. Grease fittings may need to be lubricated or rod end or bearings may need to be replaced.

- **Scraping noise coming from hopper area**

**Fruit lift mechanism is dragging on hopper.**

Call Service Provider

**NOTE: IF AN OPERATIONAL PROBLEM PERSISTS AFTER TROUBLESHOOTING, CONTACT YOUR SERVICE PROVIDER FOR ASSISTANCE.**

## Juicing Components

Item	Qty	Part Number	Description
1	1	004220037	Pin, Quick Release, Ring Grip
2	1	004406003	Screw, Machine, Round, #4-40 X 3/16" Lg, 304SS
3	1	06000004	Cup, Lower, Machined
4	1	06000022	Nozzle, Straight, FDA Grade
5	1	06000027	Cup, Upper, Assembly
6	1	06000225	Cutter and Knives, Machined
7	2	06000098	Nut, Spanner
8	1	06000108	Manifold, Juice
9	1	06010073	Screw, Spanner
10	1	06010143	Tube, Orifice, Snap In
11	1	007486119	O-Ring, Nozzle, Viton, 1/16" Section

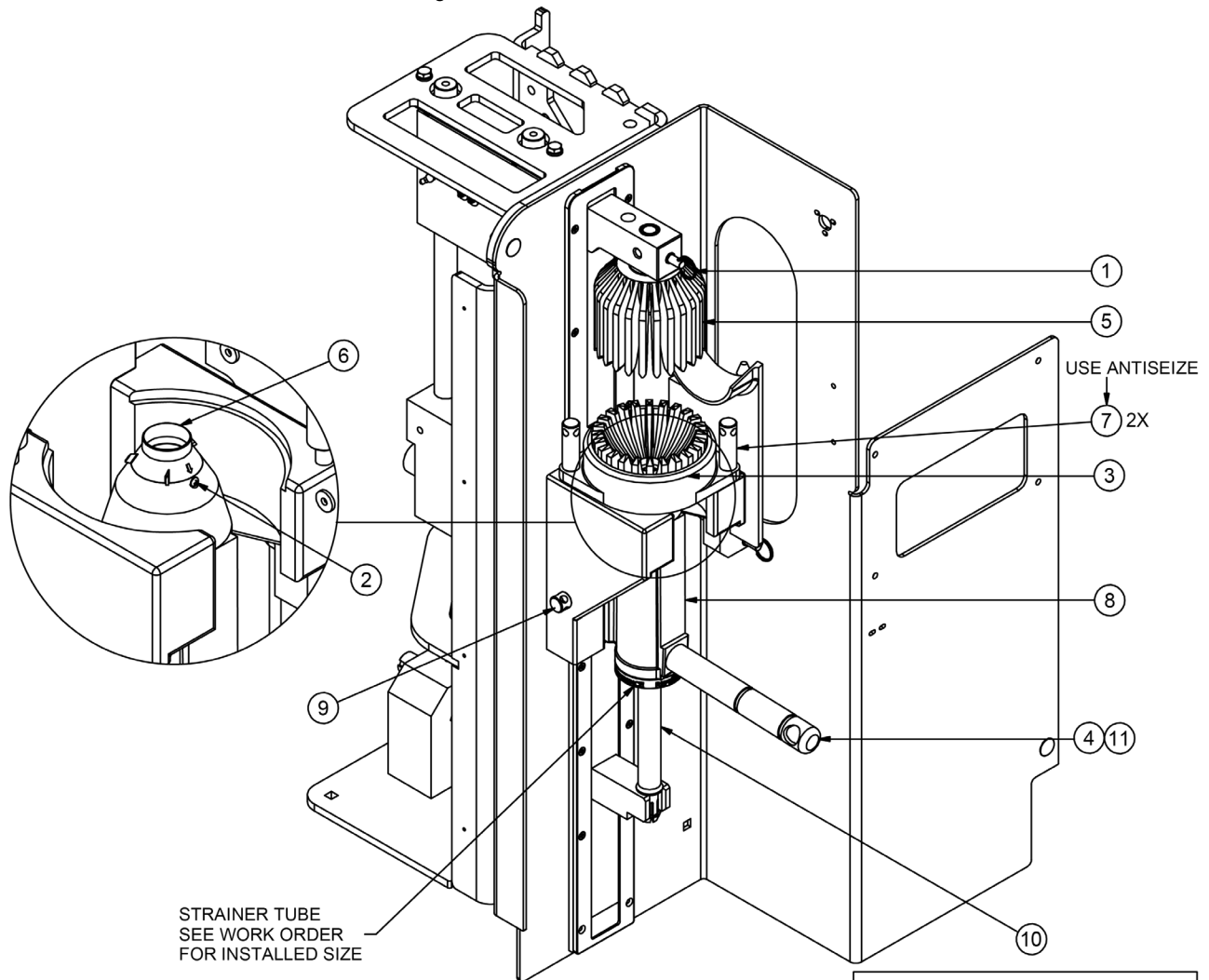

### NOTES:

- NEVER PLACE HANDS IN BETWEEN CUPS.
- CHECK CLEARANCE WHEN CUP MOVES UP AND DOWN, DO NOT PLACE HANDS IN BETWEEN CUPS WHILE DOING SO.
- ENSURE CUPS MESH WITH NO MAJOR ALIGNMENT ISSUES BEFORE PROCEEDING.
- USE APPROPRIATE STRAINER TUBE PER WORK ORDER. USE TABLE (CHOOSE ONE).

STRAINER TUBE SELECTION	
STRAINER TUBE SIZE	DWG / PN
0.028"	06000289
0.033"	06000086
0.040"	06000208
0.055"	06000230

**Figure 10. Juicing Components**



## Self-Service Specific Juicing Components

<u>Item</u>	<u>Qty</u>	<u>Part Number</u>	<u>Description</u>
1	1	06010494	Handle Momentary
1a	1	06010495	Handle Continuous
2	1	06010485	Spout Cap
3	1	06010482	Spout Body
4	1	06010479	Self-Service Housing
5	1	06010442	Manifold with Vent
6	1	06010429	Drip Tray Cover
7	1	009210043	Seat Cup
8	1	009210042	Stem
9	1	009210041	Spring
10	1	007486119	O-Ring Nozzle

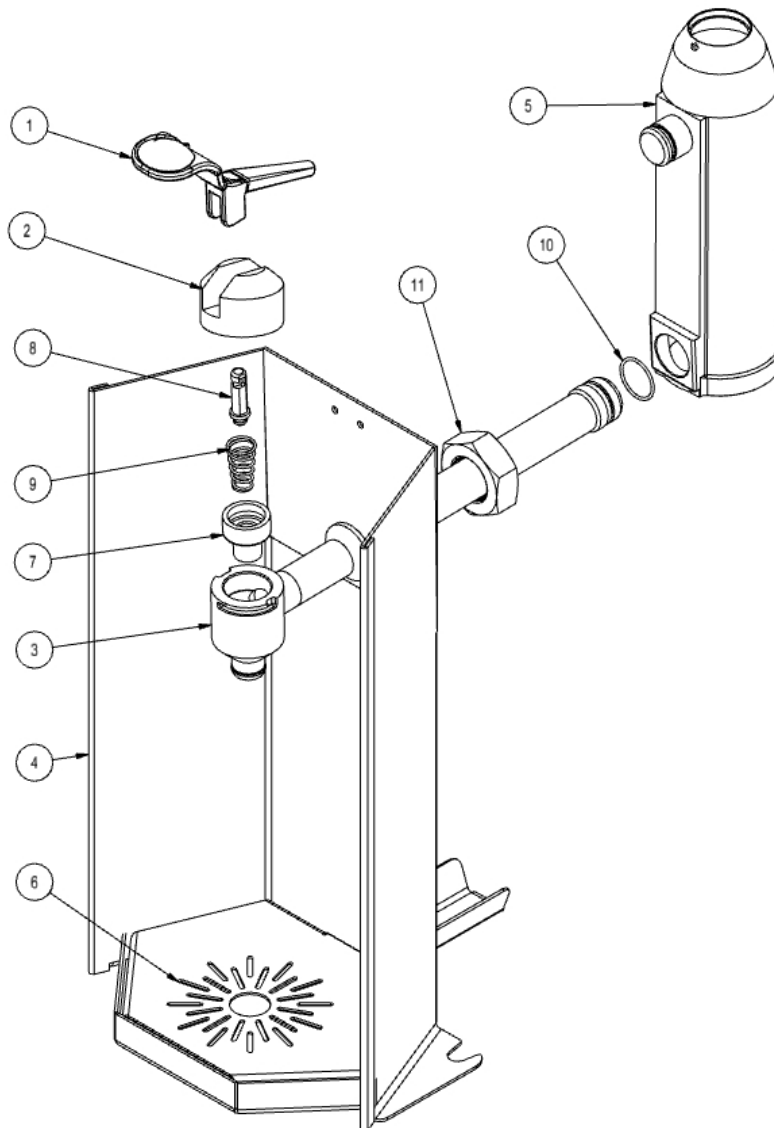

**Figure 11. Self-Service Specific Juicing Components**

## Splash Shield, Waste Bin, Tools and Accessories

Item	Qty	Part Number	Description
1	1	003091001-2	Cleaner, Corklean, 2 lbs
2	1	009080327	Brush, Dish
3	1	009080328	Brush, Tube, 1"
4	1	009092018	Cap, Cover
5	1	009092023	Waste Container, 21" X 17" X 12", Polyethylene, Grey
6	1	009710031	Stone, Sharpening, Half Round
7	1	06000077	Tool, Wrench, 5/16" Diameter
8	1	06000084	Rod, Orifice Clean Out
9	1	06001127	Cleaning Component Kit
10	1	06010188	Splash Shield
11	1	06010359	Triple Fruit Sizer, Hand-Held

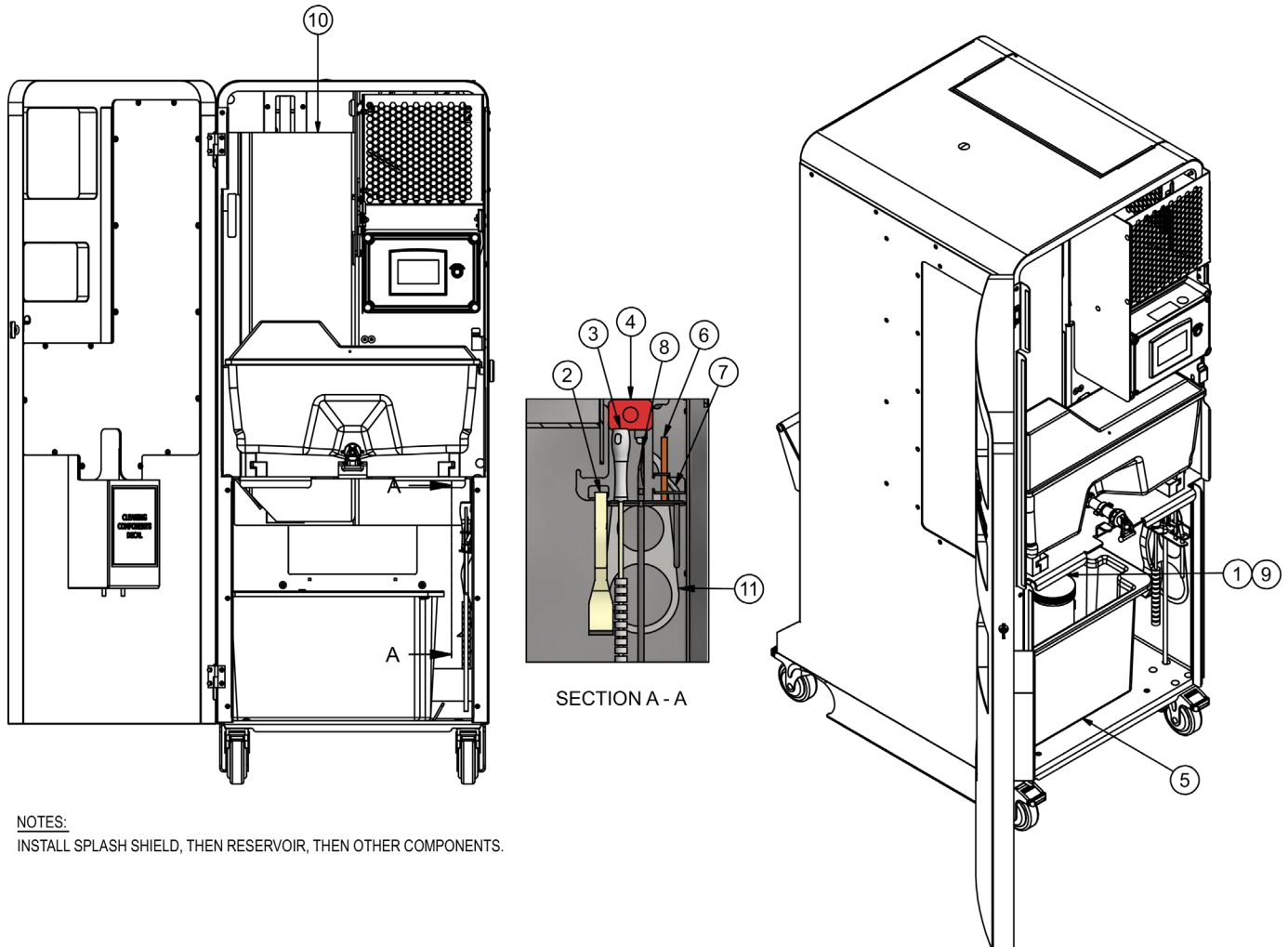

Figure 12. Splash Shield, Waste Bin, Tools and Accessories



[www.jbtcorporation.com](http://www.jbtcorporation.com)