



*Warewashing Systems*

# OPERATION AND SERVICE MANUAL



# FLIGHTSTAR<sup>®</sup>

RACKLESS CONVEYOR FLIGHT-TYPE DISHMACHINES

FlightStar Manual • 07610-004-81-74-C

**MANUFACTURER'S LIMITED WARRANTY  
(APPLICABLE ONLY IN THE UNITED STATES AND CANADA)**

**WARRANTY REGISTRATION:**

To register your Jackson Dishmachine's warranty go to [jacksonwws.com/warranty](http://jacksonwws.com/warranty) or call 1-888-800-5672. Failure to register the Dishmachine will void the warranty.

**ONE YEAR LIMITED PARTS AND LABOR WARRANTY**

For a period of one (1) year from date of original installation of a new Jackson Dishmachine (but in no event to exceed eighteen (18) months from date of shipment from Jackson's factory), Jackson WWS, Inc. (Jackson) will repair or replace, at its discretion, any original part that proves defective in materials or workmanship at the time the Dishmachine was purchased; provided that (i) the Dishmachine has not been altered, (ii) the Dishmachine has been properly installed, maintained, and operated under normal use conditions and in accordance with the applicable installation, operation and service manual available on the Jackson website, and (iii) a warranty claim is reported to a Jackson Authorized Service Agency within the warranty period. This warranty includes replacement with Jackson specified genuine replacement parts, purchased directly from a Jackson Authorized Parts Distributor or Service Agency. Use of generic replacement parts may create a hazard and shall void this warranty.

**THIS WARRANTY DOES NOT APPLY OUTSIDE THE UNITED STATES AND CANADA.**

Jackson will pay the labor to repair or replace a defective original part as a part of the warranty, provided that a Jackson Authorized Service Agency performs the labor. Any repair or replacement work by anyone other than a Jackson Authorized Service Agency is the sole responsibility of the purchaser. Labor coverage is limited to regular hourly rates; Jackson will not pay overtime premiums or emergency service charges. Accessory components (such as table limit switches, pressure regulators, and drain water tempering kits) that are not installed by Jackson at the factory and are shipped with the Dishmachine carry only a (1) one-year parts warranty. Labor to repair or replace these components is not included in the warranty or covered by Jackson. Booster heaters not manufactured by Jackson are not covered by this warranty but are warranted by their respective manufacturers. This warranty is void if any defect or failure is a direct result from shipping, handling, fire, water, accident, alteration, modification, misuse, abuse, flood, acts of God, burglary, casualty, attempted repair by unauthorized persons, use of replacement parts not authorized by Jackson, improper installation, installation not in accordance with local electrical and plumbing codes, if the serial number has been removed or altered, if the Dishmachine is used for any purpose other than originally intended, or if the equipment is installed for residential use. Jackson does not authorize any other entity or person, including, without limitation, any entity or person who deals in Jackson Dishmachines, to change this warranty or create any other obligation in connection with Jackson Dishmachines.

**TRAVEL LIMITATIONS:**

Jackson limits warranty travel time to the customer site within 50 miles of the Jackson authorized service agent's office and during regular business hours. Jackson will not pay for travel time and mileage that exceeds these limits, or any fees such as those for air or boat travel without prior authorization.

**REPLACEMENT PARTS WARRANTY:**

For a period of (90) ninety days from the date of installation by a Jackson Authorized Service Agency (but in no event to exceed (180) one-hundred-eighty days from the date of purchase from a Jackson Authorized Parts Distributor or Service Agency), Jackson will repair or replace, at its discretion, any Jackson genuine replacement parts that prove defective in materials or workmanship at the time the replacement parts were installed. This warranty does not include paying the labor to repair or replace the replacement part. This warranty is subject to all conditions, exclusions and limitations applicable to the Dishmachine.

**MANUFACTURER'S LIMITED WARRANTY (CONT.)  
(APPLICABLE ONLY IN THE UNITED STATES AND CANADA)**

**PRODUCT CHANGES:**

Jackson reserves the right to make changes in design and specification of any component of the Dishmachine as engineering or necessity requires.

**DISCLAIMER OF WARRANTIES:**

**THERE ARE NO WARRANTIES, EXPRESSED OR IMPLIED, INCLUDING, WITHOUT LIMITATION, ANY IMPLIED WARRANTY OF FITNESS FOR A PARTICULAR PURPOSE OR MERCHANTABILITY, THAT ARE NOT SET FORTH HEREIN, OR THAT EXTEND BEYOND THE DURATION HEREOF.**

**LIMITATION OF REMEDIES AND LIABILITIES:**

**YOUR SOLE AND EXCLUSIVE REMEDY UNDER THIS LIMITED WARRANTY SHALL BE PRODUCT REPAIR OR REPLACEMENT AS PROVIDED HEREIN.**

**UNDER NO CIRCUMSTANCES WILL JACKSON BE LIABLE FOR ANY INCIDENTAL OR CONSEQUENTIAL DAMAGES, OR FOR DAMAGES IN THE NATURE OF PENALTIES. JACKSON'S LIABILITY ON ANY CLAIM OF ANY KIND WITH RESPECT TO THE GOODS OR SERVICES COVERED HEREUNDER SHALL IN NO CASE EXCEED THE PRICE OF THE GOODS OR SERVICES OR PART THEREOF WHICH GIVES RISE TO THE CLAIM.**

**ITEMS NOT COVERED:**

THIS WARRANTY DOES NOT COVER (1) ADJUSTMENTS INCLUDING, BUT NOT LIMITED TO, TIMER CAMS, THERMOSTATS, DOORS, TANK HEATER ADJUSTMENTS OR CLUTCHES; (2) AIR FREIGHT OR OVERNIGHT FREIGHT; (3) ANY AMOUNT EXCEEDING ORIGINAL PURCHASE PRICE; (4) CLEANING OF DRAIN VALVES, GAS LINES, RINSE/WASH NOZZLES, STRAINERS, SCREENS, OR SPRAY PIPES; (5) CLEANING OR DELIMING OF THE DISHMACHINE OR ANY COMPONENT INCLUDING, BUT NOT LIMITED TO, WASH ARMS, RINSE ARMS AND STRAINERS; (6) CONDITIONS CAUSED BY THE USE OF INCORRECT (NON-COMMERCIAL) GRADE DETERGENTS; (7) CORROSION FROM CHEMICALS DISPENSED IN EXCESS OF RECOMMENDED CONCENTRATIONS; (8) COSMETIC DAMAGE, INCLUDING BUT NOT LIMITED TO, SCRATCHES, DENTS, CHIPS, AND OTHER DAMAGE TO THE DISHMACHINE FINISHES, UNLESS SUCH DAMAGE RESULTS FROM DEFECTS IN MATERIALS AND WORKMANSHIP AND IS REPORTED TO JACKSON WITHIN (30) THIRTY DAYS FROM THE DATE OF INSTALLATION; (9) DAMAGE CAUSED BY LABOR DISPUTE; (10) DAMAGES RESULTING FROM IMPROPER CONNECTION TO UTILITY SERVICE; (11) DAMAGES RESULTING FROM WATER CONDITIONS, INADEQUATE OR EXCESSIVE WATER PRESSURE, ACCIDENTS, ALTERATIONS, IMPROPER USE, ABUSE, HANDLING, OVERLOADS, TAMPERING, IMPROPER INSTALLATION OR FAILURE TO FOLLOW MAINTENANCE AND OPERATING PROCEDURES; (12) DISCOLORATION, RUST OR OXIDATION OF SURFACES RESULTING FROM CAUSTIC OR CORROSIVE ENVIRONMENTS, INCLUDING, BUT NOT LIMITED TO, HIGH SALT CONCENTRATIONS, HIGH MOISTURE OR HUMIDITY, OR EXPOSURE TO CHEMICALS; (13) ELECTRIC BOOSTERS, FEED LINES, FLEX HOSE, FUSES, GARBAGE DISPOSALS, OR GAS PILOTS; (14) EXCESSIVE LIME, MINERAL, OR ALKALINE BUILDUP; (15) EXPENSES DUE TO DISCONNECTION, DELIVERY, RETURN AND REINSTALLATION; (16) FAILURE OF ELECTRICAL COMPONENTS DUE TO CONNECTION OF CHEMICAL DISPENSING EQUIPMENT INSTALLED BY OTHERS; (17) FAILURE OF FACILITY WATER HEATER TO MAKE TEMPERATURE; (18) FAILURE TO MAINTAIN WATER HARDNESS LOWER THAN 3.0 GRAINS, PH BETWEEN 7.0 AND 8.5 AND TOTAL DISSOLVED SOLIDS BELOW 250 PPM; (19) FAILURE TO COMPLY WITH LOCAL ELECTRICAL BUILDING CODES; (20) LEAKS OR DAMAGE RESULTING FROM SUCH LEAKS CAUSED BY THE INSTALLER, INCLUDING THOSE AT MACHINE TABLE CONNECTIONS, OR BY CONNECTION OF CHEMICAL DISPENSING EQUIPMENT INSTALLED BY OTHERS; (21) OPENING OR CLOSING OF UTILITY SUPPLY VALVES OR SWITCHING OF ELECTRICAL SUPPLY CURRENT; (22) PERFORMANCE OF REGULAR MAINTENANCE AND CLEANING AS OUTLINED IN THE OPERATOR'S GUIDE; (23) REMOVAL OR REINSTALLATION OF INACCESSIBLE DISHMACHINES OR BUILT-IN FIXTURES THAT INTERFERE WITH SERVICING, REMOVAL OR REPLACEMENT OF THE DISHMACHINE; (24) REPLACEMENT WEAR ITEMS INCLUDING, BUT NOT LIMITED TO, CURTAINS, DRAIN BALLS, DOOR GUIDES, GASKETS, O-RINGS, SEALS, SQUEEZE TUBES, AND BEARINGS; (25) RESIDENTIAL USE; (26) USE WITH UTILITY SERVICE OTHER THAN THAT DESIGNATED ON THE RATING PLATE.

## REVISION HISTORY

Revision	Date	Made by	Process	Details
A	9-16-20	JH	N/A	Initial release of manual.
B	9-27-22	JH	8889 8897	Added: steam schematic, override switch to pre-wash control box, water connection port to booster plumbing, steam model specs, door panel components, photoeye, and programming section. Changed/corrected: overloads, 230 V booster P/N, I/O module fuse, curtain in final rinse, and high-limit thermostat. Updated: rails and schematics.
C	4-9-24	JH	8858 22-1647 22-1648 22-1649 23-1753	Added: fill hose P/Ns to final rinse section, link to steam booster manual on steam booster page, hinges, door switch, and magnet to door page. Added to unload section: R-L drive motor assemblies, gear drives, limit switch, shut-off arm hardware, spring rod, and spring. Changed photoeye sensor P/N. Corrected page numbers on reference diagram page. Updated: rails and steam schematic.



## **FlightStar**

**FlightStar - Electric-heated rackless conveyor dishmachine**  
**FlightStar Steam - Steam-heated rackless conveyor dishmachine**

The manufacturer provides technical support for all of the dishmachines detailed in this manual. We strongly recommend that you refer to this manual before making a call to our technical support staff. Please have this manual open when you call so that our staff can refer you, if necessary, to the proper page. Technical support is not available on holidays.

Contact technical support toll free at 1-888-800-5672.

Technical support is available for service personnel only.

# TABLE OF CONTENTS

## SPECIFICATIONS

Dimensions .....	1
Steam Dimensions.....	3
Exhaust Fan Dimensions.....	5
Operating Parameters .....	6
Electrical Requirements.....	7

## INSTALLATION

Installation Instructions.....	10
<i>Note on Installation</i> .....	10
<i>Curtain Locations</i> .....	10

## OPERATION

Operation Instructions .....	11
<i>Preparation</i> .....	11
<i>Power Up</i> .....	11
<i>Ware Preparation</i> .....	11
<i>Filling the Machine</i> .....	12
<i>Conveyor Speeds</i> .....	12
<i>Daily Machine Preparation</i> .....	12
<i>Washing Ware</i> .....	13
<i>Operational Inspection</i> .....	13
<i>Shutdown &amp; Cleaning</i> .....	13
Detergent Control .....	16
Deliming .....	17
Deliming Electric Booster .....	17

## MAINTENANCE

Maintenance Overview, Pre-Scrapping, Strainers.....	18
Daily and Weekly Maintenance .....	19
Monthly Maintenance .....	20
Quarterly and Annual Maintenance .....	21
Items That Should Not Require Maintenance and Items of Note .....	22

## TROUBLESHOOTING

Programming .....	23
Troubleshooting.....	25

## PARTS

Reference Diagram.....	28
Load Section.....	29
Load Expansion .....	31
Load Section Drain Plumbing .....	32
Load Section Expansion Drain Plumbing .....	33
Conveyor Belt .....	34
Pre-wash Section .....	35
Pre-wash Control Box.....	36
Pre-wash Arms & Drain Plumbing .....	38

# TABLE OF CONTENTS

## PARTS

Wash Section.....	40
Wash Control Box.....	41
Wash Arms & Drain Plumbing .....	43
Wash Steam Coil & Plumbing, L-R.....	45
Wash Steam Coil & Plumbing, R-L.....	46
Power Rinse Section.....	47
Power Rinse Control Box .....	48
Power Rinse Arms & Drain Plumbing .....	50
Power Rinse Steam Coil & Plumbing, L-R .....	52
Power Rinse Steam Coil & Plumbing, R-L.....	53
Electrical Section.....	54
Electrical Control Box .....	55
Motor Overloads .....	57
Display .....	58
Display Panel.....	59
Electric Booster & Plumbing .....	60
Steam Booster & Plumbing .....	62
Final Rinse Plumbing & Arms .....	64
Blower Dryer.....	66
Blower Assembly .....	68
Unload Section.....	70
Unload Section 36" Expansion .....	72
Unload Section 18" Expansion .....	74
Pre-wash/Wash/Power Rinse Motor.....	76
Wash/Power RinseHeaters .....	77
Doors .....	78
Frame.....	79
Strainers & Curtains .....	80

## SCHEMATICS

208-230-460 Volt/50-60 Hz/3 Phase .....	82
Steam 208-230-460 Volt/50-60 Hz/3 Phase .....	85

## SYMBOLS



- Risk of Injury to Personnel



- Risk of Damage to Equipment



- Risk of Electrical Shock



- Caustic Chemicals



- Reference Data Plate



- Lockout Electrical Power

**NOTICE** - Important Note



- Instructions Hyperlink

## ABBREVIATIONS & ACRONYMS

**A** - Amps  
**ANSI** - American National Standards Institute  
**FPM** - Feet per Minute  
**GHT** - Garden Hose Thread  
**GPG** - Grains per Gallon  
**GPH** - Gallons per Hour  
**GPM** - Gallons per Minute  
**HP** - Horse Power  
**Hz** - Hertz  
**ID** - Inside Diameter  
**kW** - Kilowatts  
**MCA** - Minimum Circuit Ampacity  
**MOP** - Maximum Overcurrent Protection  
**NFPA** - National Fire Protection Association  
**NPT** - National Pipe Thread  
**OD** - Outside Diameter  
**PRV** - Pressure Regulating Valve  
**PSI** - Pounds per Square Inch  
**V** - Volts

**LEFT-TO-RIGHT**

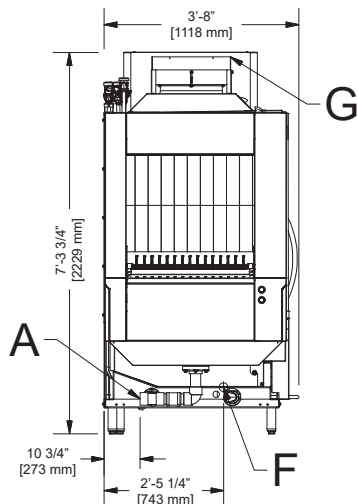
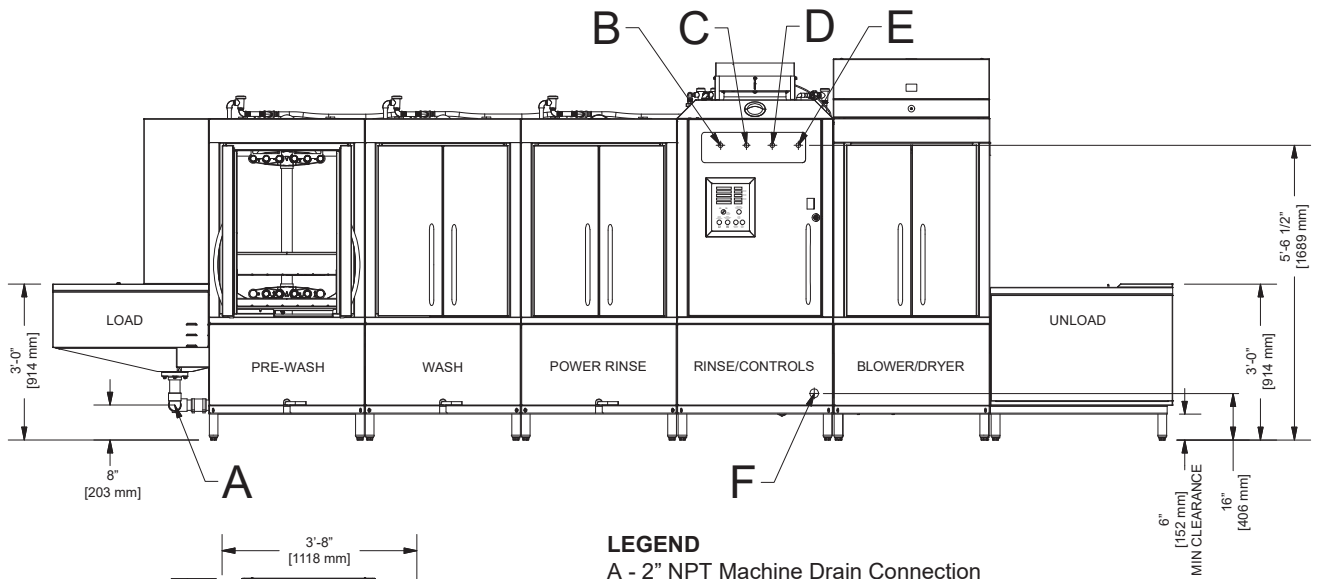
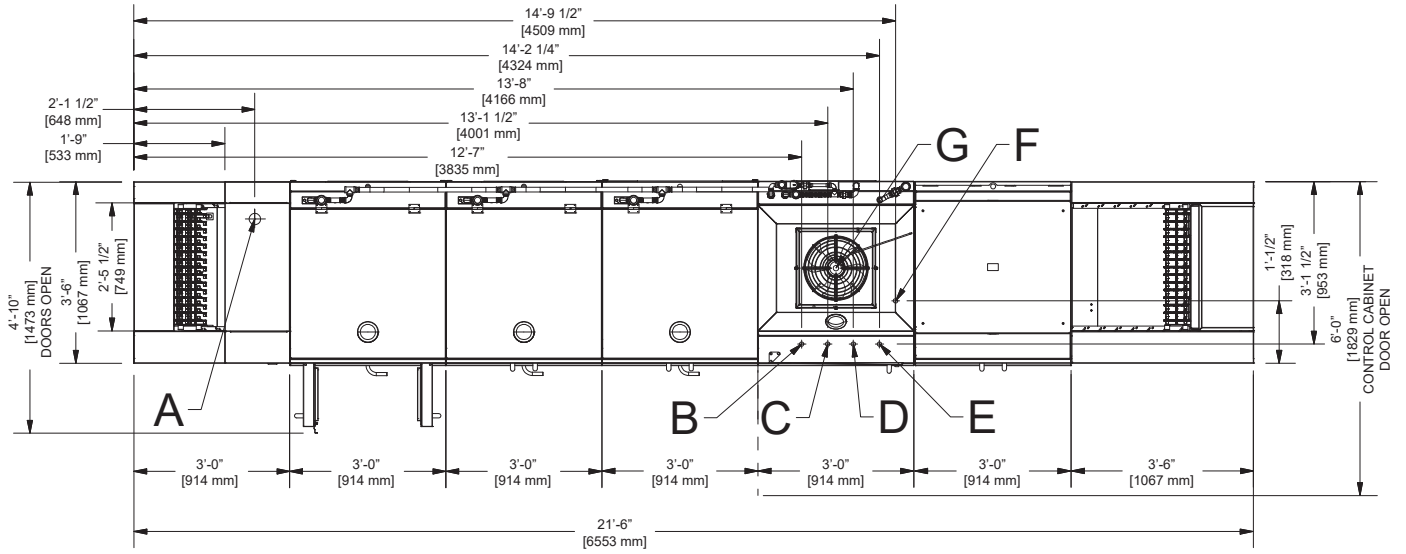

**LEGEND**

- A - 2" NPT Machine Drain Connection  
*(Floor drain - optional to either end)*
- B - Booster Heater Electrical Connection
- C - Wash Tank Electrical Connection
- D - Power Rinse Tank Electrical Connection
- E - Blower/Controls/Pre-wash Electrical Connection
- F - 3/4" NPT Incoming Water Connection
- G - Vent Connection *(Adjustable)*

*4-point electrical connection shown.*

*All dimensions from the floor can be increased 2" using the machine's adjustable feet.*

**RIGHT-TO-LEFT**

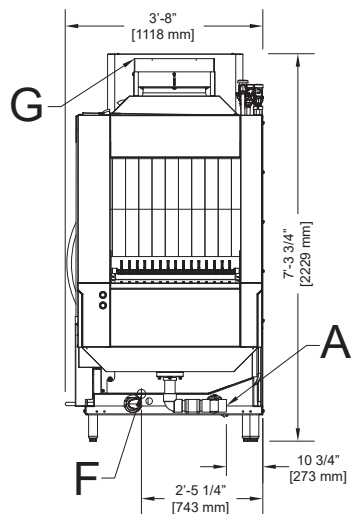
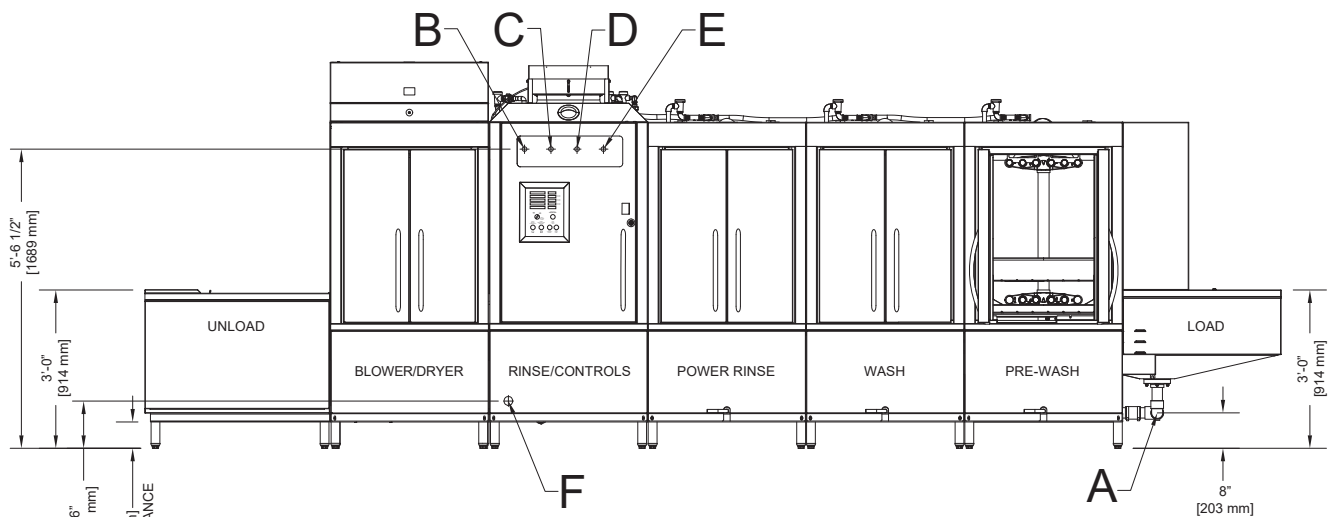
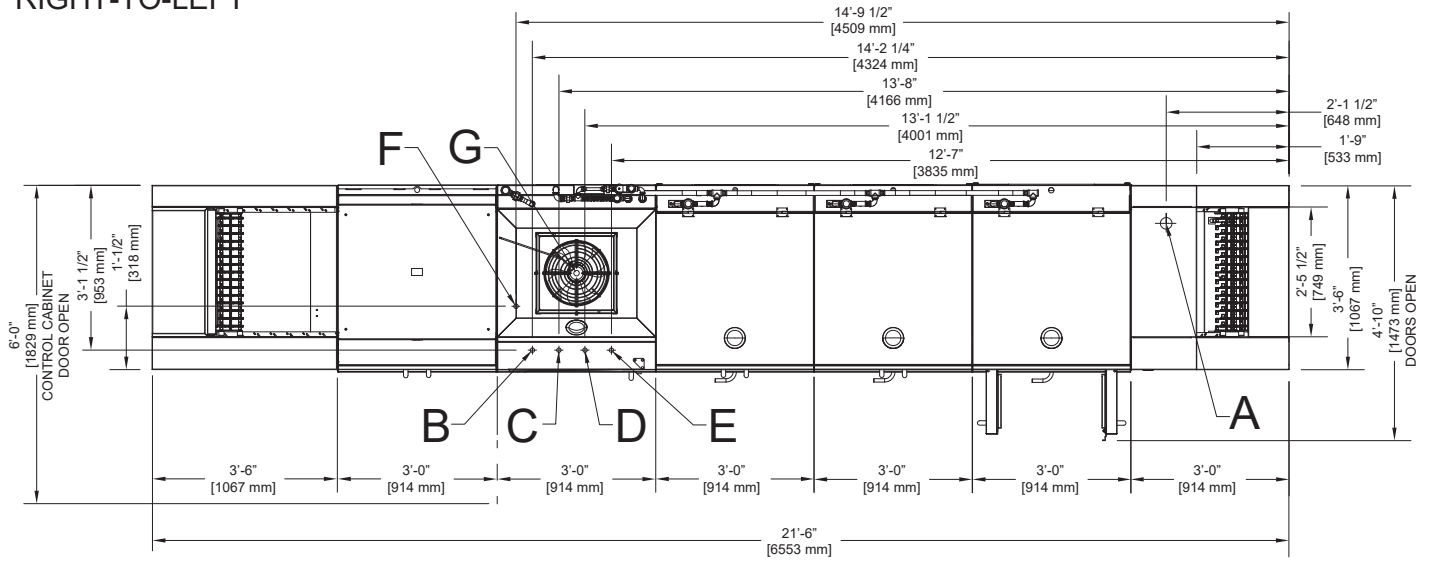

**LEGEND**

- A - 2" NPT Machine Drain Connection  
(Floor drain - optional to either end)
- B - Booster Heater Electrical Connection
- C - Wash Tank Electrical Connection
- D - Power Rinse Tank Electrical Connection
- E - Blower/Controls/Pre-wash Electrical Connection
- F - 3/4" NPT Incoming Water Connection
- G - Vent Connection (Adjustable)

4-point electrical connection shown.

All dimensions from the floor can be increased 2" using the machine's adjustable feet.

## LEFT-TO-RIGHT

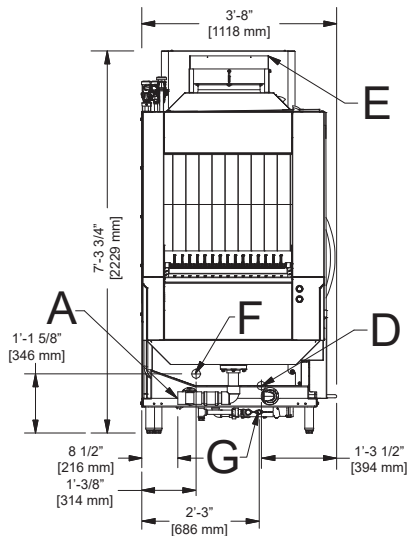
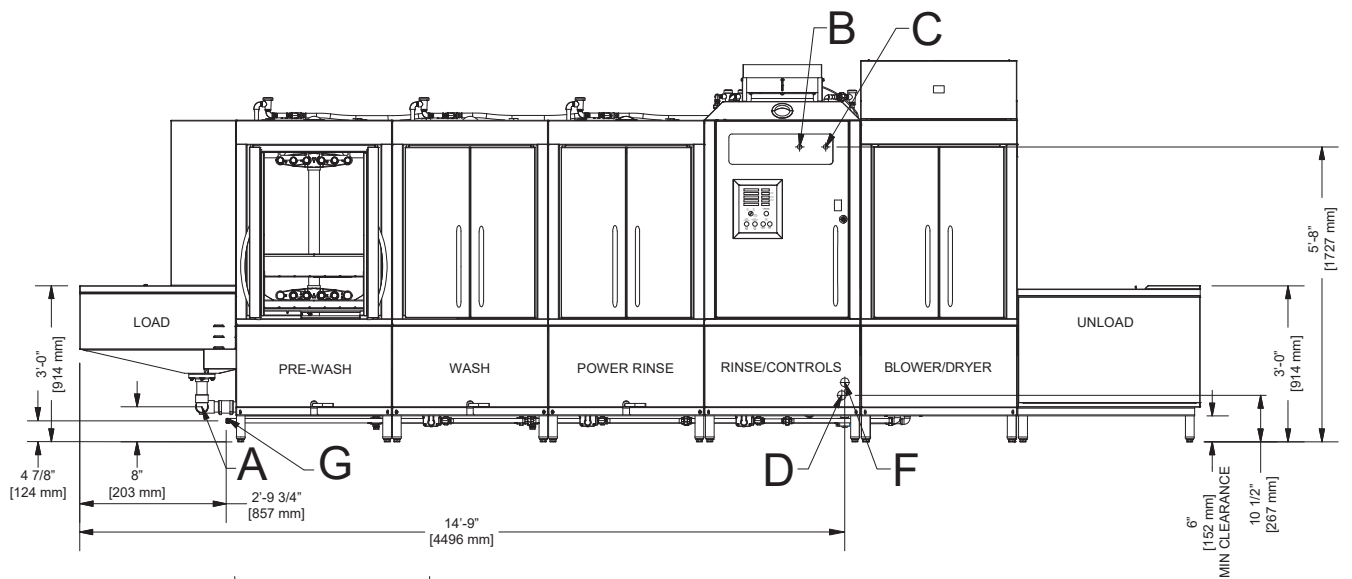
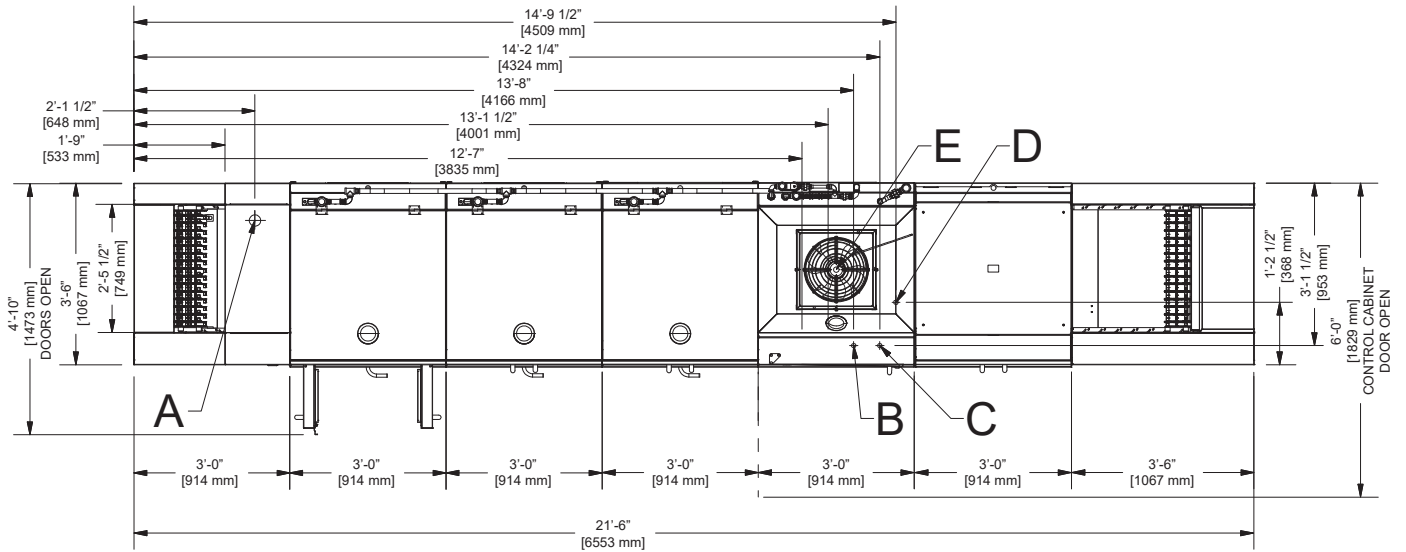

### LEGEND

- A - 2" NPT Machine Drain Connection  
*(Floor drain - optional to either end)*
- B - Wash/Power Rinse Electrical Connection
- C - Blower/Controls/Pre-wash Electrical Connection
- D - 3/4" NPT Incoming Water Connection
- E - Vent Connection *(Adjustable)*
- F - 3/4" NPT Machine Steam Inlet
- G - 3/4" NPT Condensate Return

2-point electrical connection shown.

All dimensions from the floor can be increased 2" using the machine's adjustable feet.

**RIGHT-TO-LEFT**

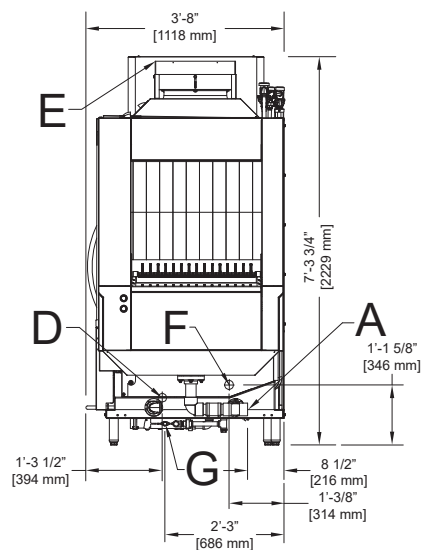
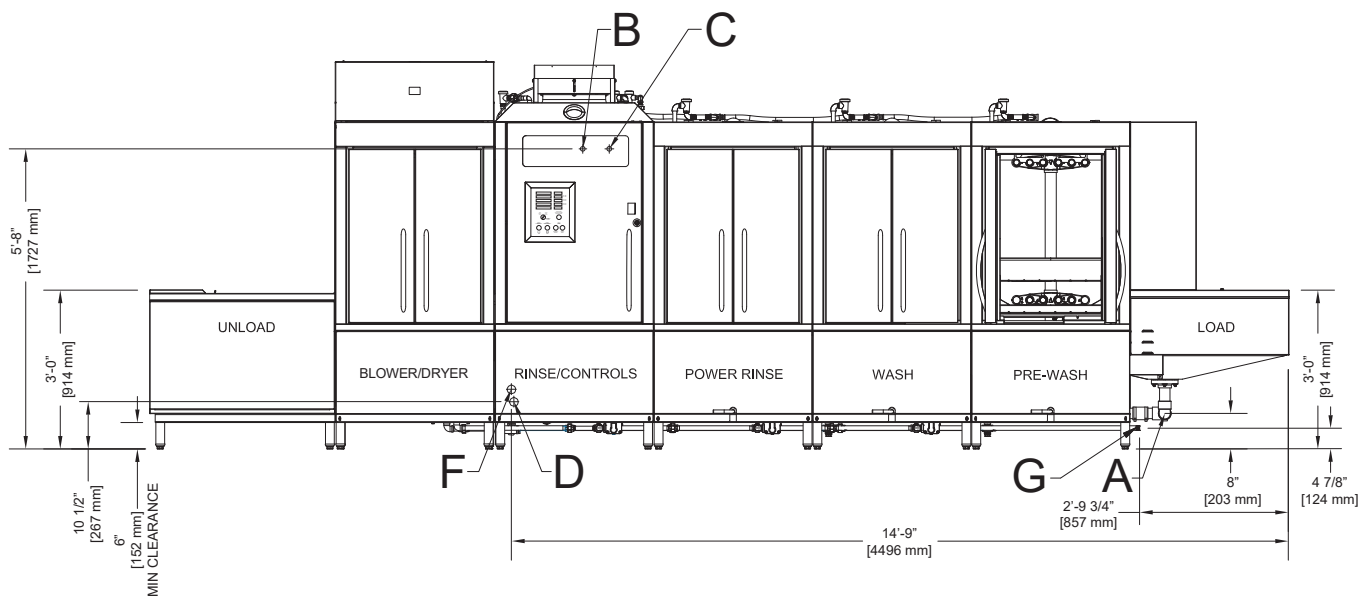
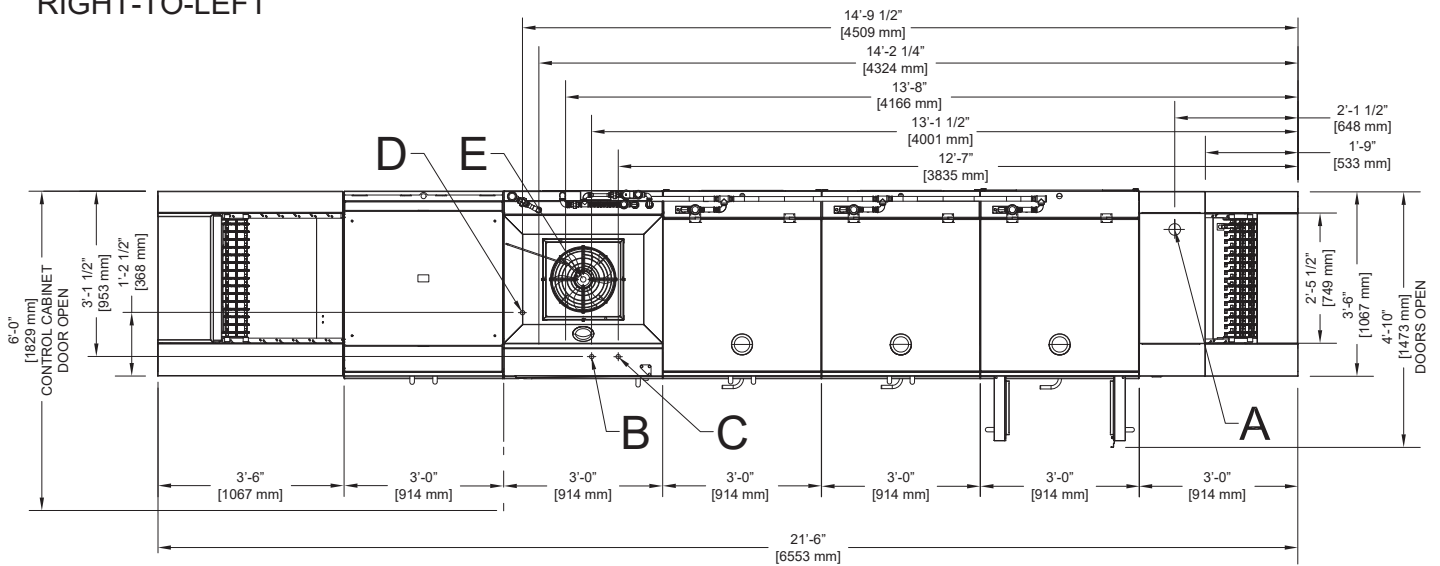

**LEGEND**

- A - 2" NPT Machine Drain Connection  
(Floor drain - optional to either end)
- B - Wash/Power Rinse Electrical Connection
- C - Blower/Controls/Pre-wash Electrical Connection
- D - 3/4" NPT Incoming Water Connection
- E - Vent Connection (Adjustable)
- F - 3/4" NPT Machine Steam Inlet
- G - 3/4" NPT Condensate Return

2-point electrical connection shown.

All dimensions from the floor can be increased 2" using the machine's adjustable feet.

**EXHAUST FAN DIMENSIONS**

**NOTICE** The condensate removal system built into the dishmachine consists of a fan that will remove 1200 CFM. A single condensate connection must be provided by the installing contractor. This is an indirect connection that must be capable of removing 1200 CFM from the area.

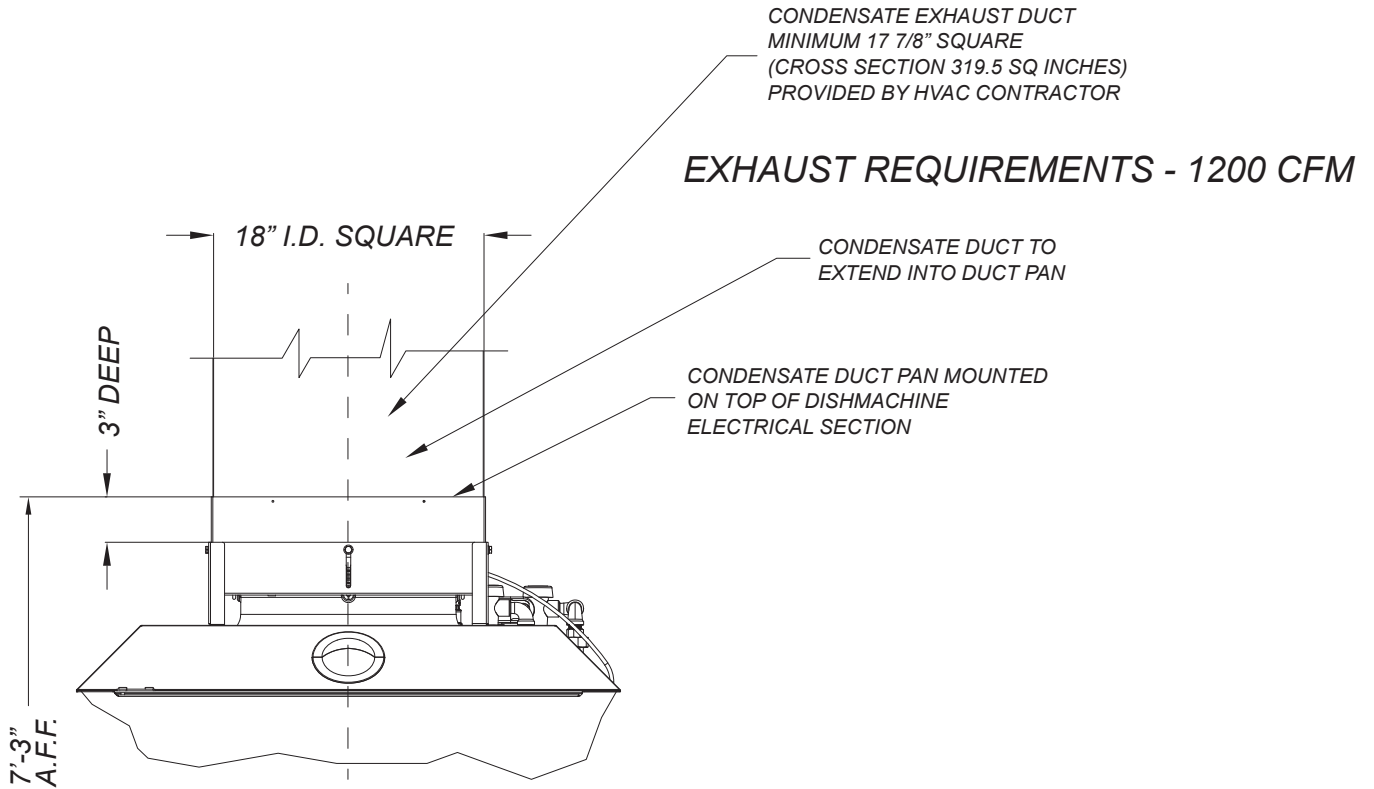

## SPECIFICATIONS

## OPERATING PARAMETERS

### Operating Capacity:

Dishes per Hour (8.6 FPM)	14,964
Dishes per Hour (6.8 FPM)	11,832

### Tank Capacity (Gallons):

Pre-wash Tank	34.2
Wash Tank	35.9
Rinse Tank	37.5

### Pump Capacity (GPM):

Pre-wash Tank	250
Wash Tank	250
Rinse Tank	250

### Venting Requirements

(CFM)(100% Capacity) (INDIRECT)	1200
------------------------------------	------

### Conveyor Speed (FPM)

High	8.6
Low	6.8

### Water Temperatures (°F):

Minimum Inlet Water Temperature	110
Recommended Pre-wash Temperature	140
Minimum Wash Temperature	150
Minimum Power Rinse Temperature	165
Minimum Final Rinse Temperature	180

### Other Water Parameters:

Water Flow Pressure (PSI)	15
Standard Rinse (GPM)	0.83
Standard Rinse (GPH)	50
Turbo Rinse (GPM)	1.53
Turbo Rinse (GPH)	92

### Steam Booster Requirements (FlightStar Steam):

Steam Flow Pressure (PSI)	10–30
Consumption at 110 °F Incoming Water Temp	317 lbs/hr
Consumption with Blower/Dryer	351 lbs/hr

Click [here](#) for the Steam Booster manual.



#### NOTICE



*Always refer to the machine data plate for specific electrical and water requirements. The material provided on this page is for reference only and is subject to change without notice.*



All electrical ratings provided in this manual are for reference only. Always refer to the machine data plate to get the exact electrical information for this machine. **All electrical work performed on machines should be done in accordance with applicable local, state, territorial, and national codes.** Work should only be performed by qualified electricians and authorized service agents.

Amperage loads for motors and heaters are indicated on the machine data plate.

The steam booster (FlightStar Steam only) has its own electrical connection and requires a separate service. Amperage loads for machine are listed on the machine data plate. Click on the instruction icon below for the Steam Booster manual.



The electrical configurations of machine components are as follows:

• Pre-wash Pump Motor	3 HP
• Wash Pump Motor	3 HP
• Power Rinse Pump Motor	3 HP
• Wash Heater 1	12 kW
• Wash Heater 2	15 kW
• Power Rinse Heater 1	15 kW
• Power Rinse Heater 2	15 kW
• Drive Motor	1/4 HP
• Exhaust Fan Motor	3.1 kW
• Blower/Dryer Motor	1.6 kW
• Blower/Dryer Heater 1	4.5 kW
• Blower/Dryer Heater 2	4.5 kW
• Electric Booster Heater	27 kW
 Idle Energy Rate	 2.31 kW



Local codes may require more stringent protection than what is displayed here and on the data plate. Always verify with your electrical service contractor that your circuit protection is adequate and meets all applicable national and local codes. Numbers in this manual are for reference and may change without notice.

**NOTICE** Imbalanced wild leg goes to L3. Also see the Motor Rotation section.

**Electric Machines with No Blower/Dryer**

208 V/60 Hz/3-Phase					
	Heater kW	Pump HP	208 V	MCA	MOP
Wash Heater & Pump Section	27	3	84.1 A	86.4 A	95 A
Power Rinse Heater & Pump Section	30	3	92.5 A	94.8 A	100 A
Motors, Pre-wash Pump, & Controls	-	3	11.3 A	13.6 A	20 A
Booster Option	27	-	74.9 A	76.2 A	80 A
230 V/60 Hz/3-Phase					
	Heater kW	Pump HP	230 V	MCA	MOP
Wash Heater & Pump Section	27	3	70.8 A	73.0 A	80 A
Power Rinse Heater & Pump Section	30	3	77.8 A	79.9 A	85 A
Motors, Pre-wash Pump, & Controls	-	3	10.7 A	12.9 A	20 A
Booster Option	27	-	65.0 A	66.3 A	70 A
460 V/60 Hz/3-Phase					
	Heater kW	Pump HP	460 V	MCA	MOP
Wash Heater & Pump Section	27	3	35.4 A	36.5 A	40 A
Power Rinse Heater & Pump Section	30	3	38.9 A	40.0 A	45 A
Motors, Pre-wash Pump, & Controls	-	3	5.5 A	6.6 A	15 A
Booster Option	27	-	32.5 A	33.8 A	35 A

**Electric Machines with Blower/Dryer**

208 V/60 Hz/3-Phase					
	Heater kW	Pump HP	208 V	MCA	MOP
Wash Heater & Pump Section	27	3	84.1 A	86.4 A	95 A
Power Rinse Heater & Pump Section	30	3	92.5 A	94.8 A	100 A
Motors, Pre-wash Pump, Controls, & Blower/Dryer	9	3	41.5 A	43.8 A	50 A
Booster Option	27	-	74.9 A	76.2 A	80 A
230 V/60 Hz/3-Phase					
	Heater kW	Pump HP	230 V	MCA	MOP
Wash Heater & Pump Section	27	3	70.8 A	73.0 A	80 A
Power Rinse Heater & Pump Section	30	3	77.8 A	79.9 A	85 A
Motors, Pre-wash Pump, Controls, & Blower/Dryer	9	3	36.6 A	38.8 A	45 A
Booster Option	27	-	65.0 A	66.3 A	70 A

**NOTICE** Electrical tables show base machine with Pre-wash section and base machine with Pre-wash and Blower/Dryer sections and are for reference only. Use machine data plate for electrical specs specific to machine that was ordered.



Local codes may require more stringent protection than what is displayed here and on the data plate. Always verify with your electrical service contractor that your circuit protection is adequate and meets all applicable national and local codes. Numbers in this manual are for reference and may change without notice.

**NOTICE** Imbalanced wild leg goes to L3. Also see the Motor Rotation section.

**Electric Machines with Blower/Dryer (Cont.)**

<b>460 V/60 Hz/3-Phase</b>					
	<b>Heater kW</b>	<b>Pump HP</b>	<b>460 V</b>	<b>MCA</b>	<b>MOP</b>
Wash Heater & Pump Section	27	3	35.4 A	36.5 A	40 A
Power Rinse Heater & Pump Section	30	3	38.9 A	40.0 A	45 A
Motors, Pre-wash Pump, Controls, & Blower/Dryer	9	3	18.9 A	19.9 A	25 A
Booster Option	27	-	32.5 A	33.8 A	35 A

**Steam Machines with No Blower/Dryer**

<b>208 V/60 Hz/3-Phase</b>				
	<b>Pump HP</b>	<b>208 V</b>	<b>MCA</b>	<b>MOP</b>
Wash Heater & Power Rinse Section	3	18.4 A	20.7 A	25 A
Motors, Pre-wash Pump, & Controls	3	11.3 A	13.6 A	20 A
<b>230 V/60 Hz/3-Phase</b>				
	<b>Pump HP</b>	<b>230 V</b>	<b>MCA</b>	<b>MOP</b>
Wash Heater & Power Rinse Section	3	17.2 A	19.4 A	25 A
Motors, Pre-wash Pump, & Controls	3	10.7 A	12.9 A	20 A
<b>460 V/60 Hz/3-Phase</b>				
	<b>Pump HP</b>	<b>460 V</b>	<b>MCA</b>	<b>MOP</b>
Wash Heater & Power Rinse Section	3	8.6 A	9.7 A	15 A
Motors, Pre-wash Pump, & Controls	3	5.5 A	6.6 A	15 A

**Steam Machines with Blower/Dryer**

<b>208 V/60 Hz/3-Phase</b>				
	<b>Pump HP</b>	<b>208 V</b>	<b>MCA</b>	<b>MOP</b>
Wash Heater & Power Rinse Section	3	18.4 A	20.7 A	25 A
Motors, Pre-wash Pump, Controls, & Blower/Dryer	3	16.5 A	18.8 A	25 A
<b>230 V/60 Hz/3-Phase</b>				
	<b>Pump HP</b>	<b>230 V</b>	<b>MCA</b>	<b>MOP</b>
Wash Heater & Power Rinse Section	3	17.2 A	19.4 A	25 A
Motors, Pre-wash Pump, Controls, & Blower/Dryer	3	15.9 A	18.1 A	25 A
<b>460 V/60 Hz/3-Phase</b>				
	<b>Pump HP</b>	<b>460 V</b>	<b>MCA</b>	<b>MOP</b>
Wash Heater & Power Rinse Section	3	8.6 A	9.7 A	15 A
Motors, Pre-wash Pump, Controls, & Blower/Dryer	3	8.5 A	9.6 A	15 A

**NOTE ON INSTALLATION**

All FlightStar models are accompanied by a certified technician for the initial installation. Problems that arise, as well as questions about the installation, should be directed to this person.

**CURTAIN LOCATIONS**

The machine has decals marking the curtain locations inside the machine, starting at the load end and ending at the unload end. The illustrations below indicate the size of the curtain to be placed on the curtain hooks provided. If any curtain components are missing, they must be obtained and installed before operation.

The curtains inside the dishmachine must be installed properly for the machine to operate correctly. Curtains are used to control air currents inside the unit and assist in maintaining the heat necessary to keep energy costs down.

See the Strainers & Curtains page for part numbers.

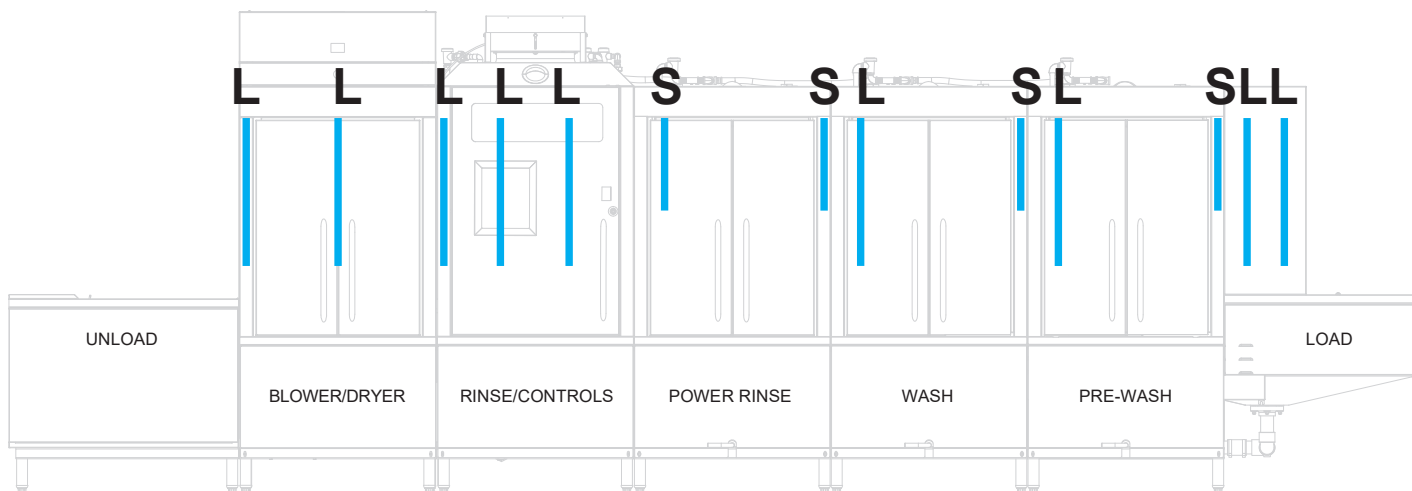
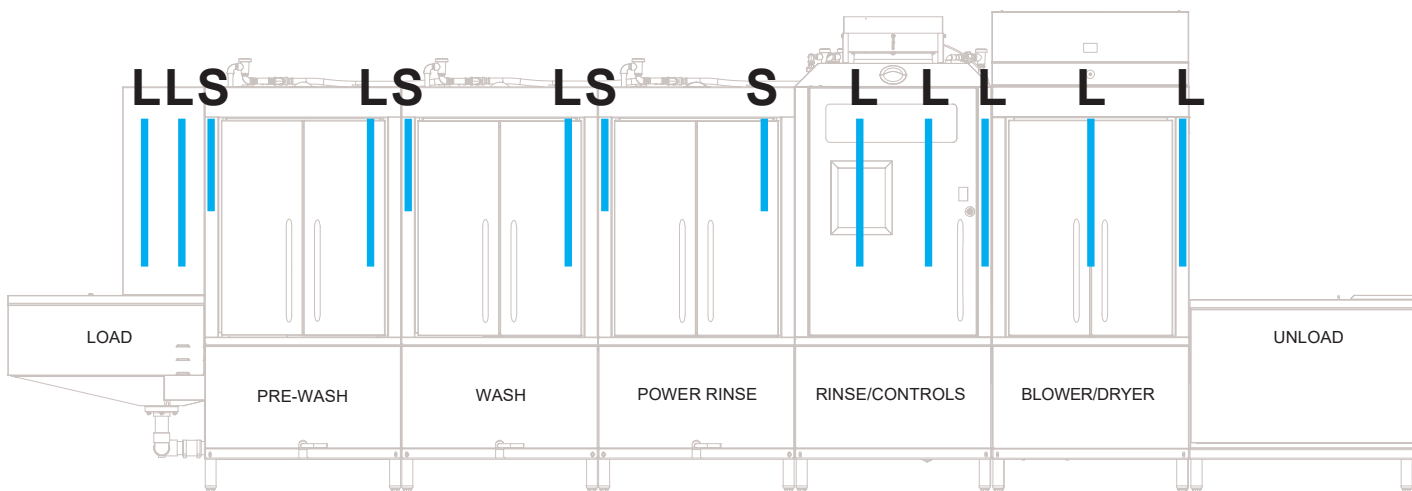

**PREPARATION** Before operating the machine, verify the following:

1. All tools, cleaning rags, and foreign parts are removed from the operation areas of the machine.
2. Wash arms, rinse arms, strainers, and curtains are all installed correctly.
3. All doors on machine are closed.
4. All drain valves are closed.
5. Main stop valves for water are open.
6. All emergency stop switches are pulled-out.
7. Main switch at the control panel is on.

**POWER UP** To energize the machine, turn on the power at the service breakers. The voltage should have been previously verified as being correct. If not, the voltage must be verified. Press the Power button on the control panel.

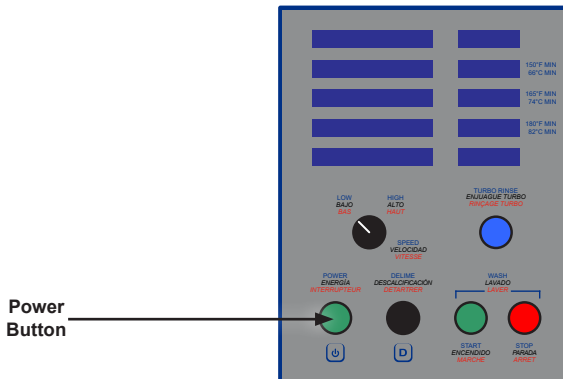

For electrical booster operation, ensure that the electric booster heater's power switch is in the ON position. This can be seen when electrical section's lower dress panel is removed. Check that the power light is illuminated.

For steam booster heater operation, ensure switch below front control door is in the ON position. The light beside the switch should be illuminated to indicate ON and the light beside the steam gauge will turn on and off depending on whether steam is cycling to the booster.

**WARE PREPARATION** Proper preparation of ware is essential for the smooth, efficient operation of this machine.

Any ware placed in the machine should have all solid food waste and scraps removed. Ware should also be sprayed-down before entering the machine.

Place cups and glasses upside-down so they don't hold water during the cycle. Pre-soak flatware in warm water to help remove food.

**FILLING THE MACHINE**

Close all doors. The display will indicate "FILLING" then "HEATING." When the display indicates "READY," the filling and heating cycle is complete and the machine is ready for operation. Press the green Start button on the display panel or at the load or unload ends. Now the conveyor belt can be loaded with ware in the load section.

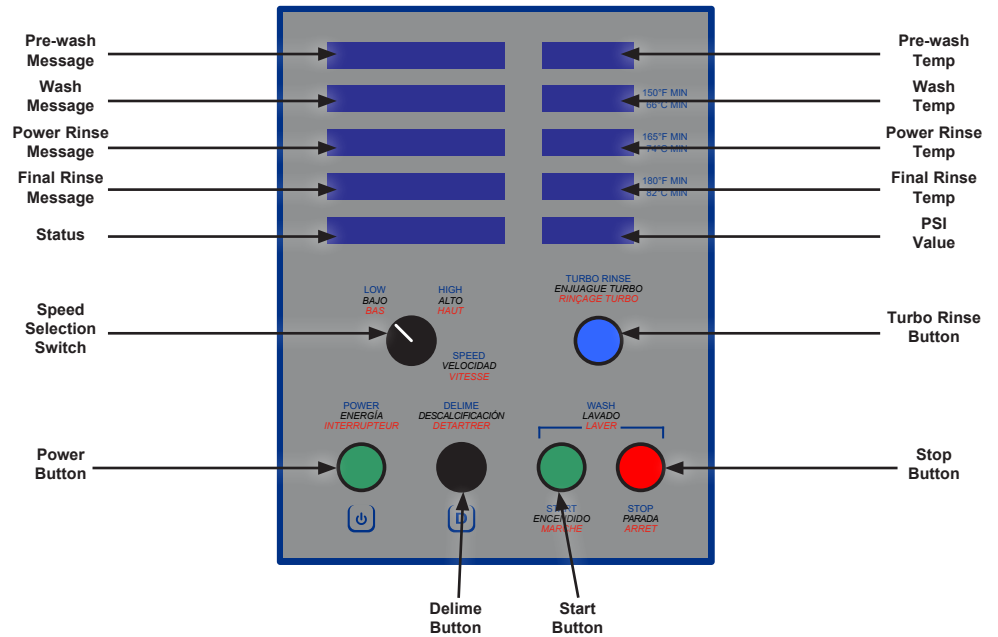

**CONVEYOR SPEEDS**

Two conveyor speeds can be selected. During operation, the conveyor speed can be changed from low to high or vice-versa. "Low" moves ware slower through the machine, which is suitable for heavily-soiled dishware. "High" moves ware quicker through the machine, which is suitable for lightly-soiled dishware. The conveyor speed must be selected according to the soiling of the dishware, the belt load, and the washing results.

**DAILY MACHINE PREPARATION**

By means of the red Stop button (located on the display panel and at each end of the machine), the operation cycle is temporarily interrupted (i.e. the wash pumps and conveyor are switched off); however, the tank heaters continue running. The operation cycle is only temporarily interrupted and remains ready for operation. The machine is in stand-by operation and can start operation at any time. After an interruption of operation, you can continue the wash cycle by pressing the green Start button on the display panel or at the load or unload ends.

Refer to the Preparation section and follow the instructions there. Afterward, check that all of the chemical levels are correct for the expected workload.

## WASHING WARE

To wash, simply place ware on the track at the load end of the machine. Place glasses upside-down and plates with the soiled side facing the unload end. Place silverware and utensils in appropriate baskets/racks for transport through the machine.



**WARNING!** Ware coming out of the dishwasher will be hot!

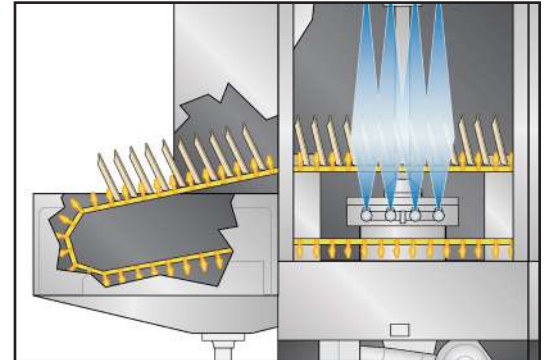

Cut-a-way detail showing direction of plates.

## OPERATIONAL INSPECTION

Based on use, the strainers can become clogged with soil and debris as the workday progresses. Operators should regularly inspect the strainers to ensure they have not become clogged. If the strainers are clogged, it will reduce the washing capability of the machine. Instruct operators to clean out the strainers at regular intervals or as required by workload.

## SHUTDOWN & CLEANING



**CAUTION!** Do not spray the machine, electrical cabinets, or other electrical parts with a water hose or high-pressure hose.

1. Push Power button.

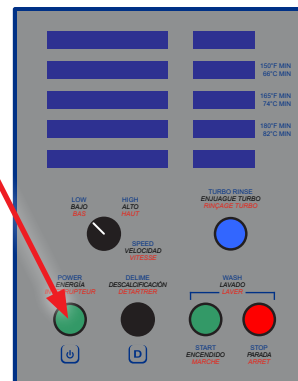

2. Open doors.

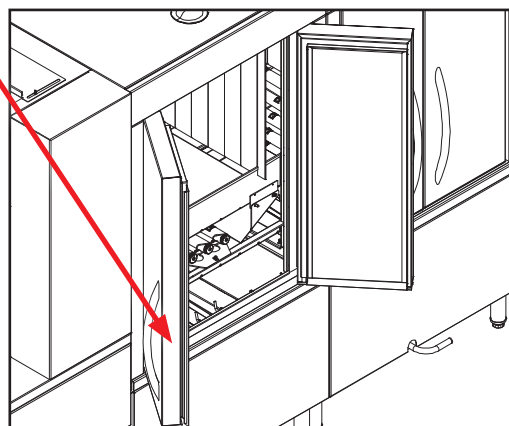

**SHUTDOWN &  
CLEANING**

3. Open drain valves and allow the machine to drain completely.

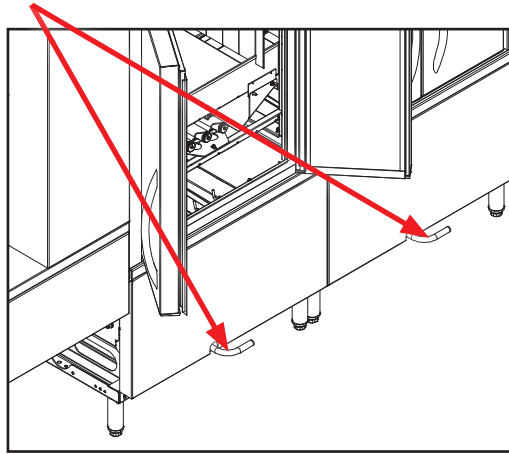

4. Remove all strainers and run-off sheets and clean.

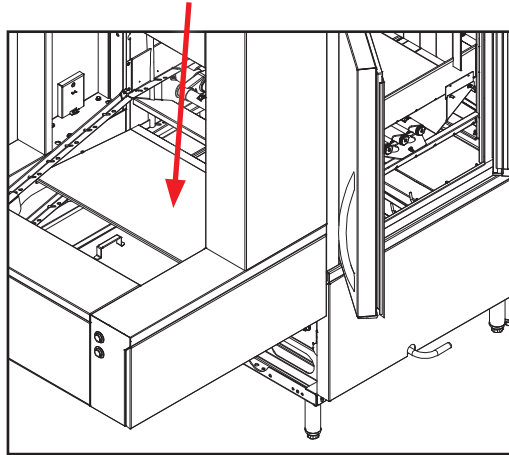

**CAUTION!** Do NOT beat strainers to remove soil and debris!

5. Remove wash, pre-wash arms, and power rinse arms and verify the nozzles and arms are free of obstructions. Use a small wire or toothpick to remove debris.

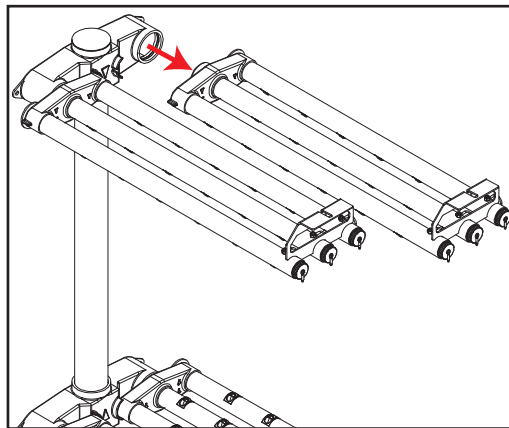

**SHUTDOWN &  
CLEANING**

6. Remove end-caps and flush arms with fresh water.

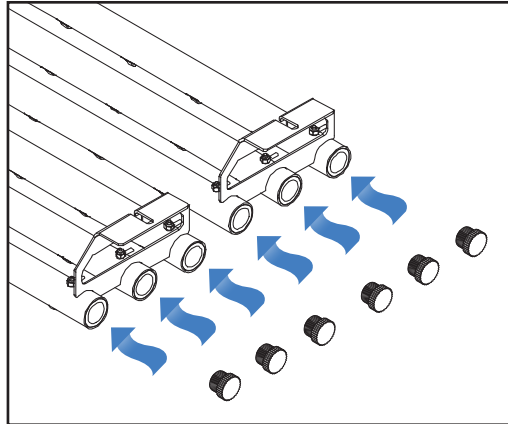

7. Remove curtains and scrub with a mild detergent and warm water. When replacing curtains, please note proper locations for re-installation.

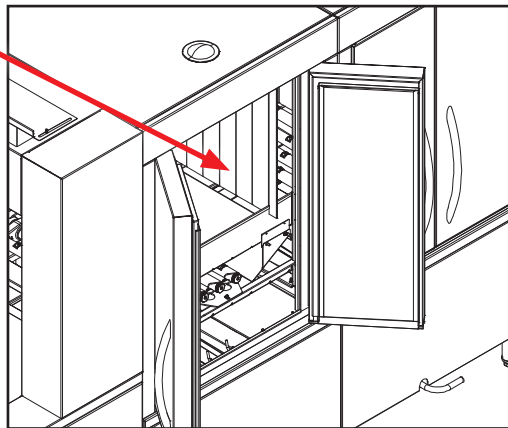

8. Wipe-out inside of the machine and replace components previously removed.

**DETERGENT  
CONTROL**

Detergent usage and water hardness are two factors that contribute greatly to how efficiently this machine will operate. Using detergent in the proper amount can become a source of substantial savings. A qualified water treatment specialist can determine what is needed for maximum efficiency from the detergent.

- Hard water greatly affects the performance of the dishmachine, causing the amount of detergent required for washing to increase. If the machine is installed in an area with hard water (greater than 3 GPG), the manufacturer recommends the installation of water treatment equipment (see Plumbing Options page).
- Deposited solids from hard water can cause spotting that will not be removed with a drying agent. Treated water will reduce this occurrence.
- Treated water might not be suitable for use in other areas of operation and it might be necessary to install a water treatment unit for the water going to the machine only. Discuss this option with a qualified water treatment specialist.
- Machine operators should be properly trained on how much detergent is to be used per cycle. Meet with a water treatment specialist and detergent vendor to discuss a complete training program for operators.
- These machines require that chemicals be provided for proper operation and sanitization and require the installation of third-party chemical feeders to introduce these chemicals to the machine. Contact a chemical supplier with any questions.
- Water temperature is an important factor in ensuring the machine functions properly. The machine's data plate details what the minimum temperatures must be. If minimum requirements are not met, there is a possibility that dishes will not be cleaned or sanitized.
- Instruct machine operators to observe the required temperatures and to report when they fall below the minimum allowed. A loss of temperature can indicate a larger problem.

**DELIMING** In order to maintain the machine at its optimum performance level, lime and corrosion deposits must be removed on a frequent basis. A deliming solution should be available from your chemical supplier. Read and follow all instructions on the label of the deliming solution.

To prepare for the deliming operation:

1. Fill the machine.
2. Add the correct amount of deliming solution as recommended by the chemical supplier.

**NOTICE** *The water capacity of the various tanks of the machine can be verified on the specification pages of this manual.*

To delime the dishmachine:

1. Push Delime button.

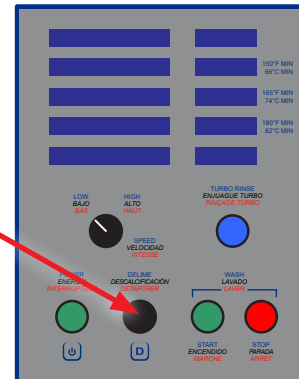

2. Once delime cycle is complete, turn the machine off and open doors.
3. Wait five minutes, then inspect inside of the machine. If the machine is not delimed, run another deliming cycle.
4. When clean, drain and re-fill the machine.
5. Run in regular cycle for 10 minutes to remove residual deliming solution.
6. Drain and re-fill the machine.



**CAUTION!** *This equipment is not recommended for use with deionized water or other aggressive fluids. Use of deionized water or other aggressive fluids will result in corrosion and failure of materials and components. Use of deionized water or other aggressive fluids will void the manufacturer's warranty.*

**DELIMING ELECTRIC BOOSTER** In order to maintain the electric booster heater at its optimum performance level, lime and corrosion deposits must be removed on a frequent basis. To delime, please refer to the instruction manual that came with the electric booster heater. A deliming solution should be available from your chemical supplier. Read and follow all instructions on the label of the deliming solution.

## MAINTENANCE OVERVIEW

The concept of preventative maintenance is to perform small checks and procedures that will limit the catastrophic failures your machine could experience. A catastrophic failure is anything that will keep the machine from operating for an extended period of time. Dishmachines, regardless of size, are very simple machines and do not require very much in the way of preventative maintenance. Listed here are some maintenance items that will prolong the life of the machine.

## PRE-SCRAPPING

It cannot be stressed enough that in order for the machine to work at peak efficiency, the introduction of food and soil must be limited. Though the FlightStar is a large machine, it is not a garbage disposal, and it contains several parts that have very small openings. These openings can become clogged very quickly if large food particles are introduced to the machine. Train operating personnel in proper scrapping techniques. This includes scraping excess food from plates and bowls and removing straws from glasses.

Some ware might require soaking before being placed in the machine, especially silverware and casserole dishes. Soaking helps loosen stuck-on food particles and aids the machine in removing such soil. Sink soak options are available and can be discussed with your authorized dealer.

## STRAINERS

Machines should be cleaned at least daily and one of the most important aspects of this task is the removal, cleaning, and proper replacement of the various strainers located throughout the machine. Strainers are added to try and prevent any debris from getting inside the pumps or in the arms of the machine. Both the pumps and the arms have very close tolerances manufactured into their design in order to deliver optimum performance.

There are generally three problems associated with strainers:

1. Not removed for cleaning. Many operators are simply unaware that the strainers can and should be removed for cleaning. How often this should be done is based on usage and is generally something that can be determined with experience. It is important, however, to not only tell operators about the strainers, but to show them where they are at and remind them that they should be cleaned regularly.
2. Damaged strainers. Many times the first impulse for cleaning strainers is to take them and beat them on the side of a garbage can. The strainers are made from stainless steel and delivering such blows to them will eventually warp them. A warped strainer does not sit flush and creates gaps that debris and soil can get through. The proper method of cleaning a strainer is to wipe it out and then rinse it with water to get any debris out. Remember that it is much easier and inexpensive to clean out a strainer than it is to replace a pump!



**CAUTION! Do NOT beat strainers to remove soil and debris!**

**STRAINERS**

3. Missing strainers. It is easy to forget to put the strainers back after removing them, so it is important to train operating personnel on the importance of putting everything back when they are finished. If the strainer was not important, it would never have been incorporated into the machine design. Strainers are implemented to prevent failure of the more expensive components of the dishmachine (e.g. pumps) and should always be replaced before operating the machine. The manufacturer strongly recommends that you do not operate the machine without the strainers as doing so not only allows damage to occur to the machine, but could also void the warranty. Train personnel to report whenever a strainer is missing or damaged so that replacements can be ordered immediately.

**DAILY MAINTENANCE**

Drain and clean the dishmachine per the instructions in this manual. During cleaning, any items that appear to be broken or failed should be reported to authorized service personnel.

**WEEKLY MAINTENANCE**

1. Delime the machine. The deliming agent that you use might require more or less frequency in application. Because water conditions vary from installation to installation, it might be necessary to delime the machine more or less often. Follow the chemical supplier's instructions regarding frequency of application and adjust the maintenance schedule as required.
2. Verify there are no leaks. This includes inspecting the integrity of all gaskets, including the ones inside the machine, as well as ensuring that none of the silicone used between the individual sections has frayed or been removed. Any torn gaskets should be immediately replaced. Re-apply silicone as required. The machine should be completely turned off and drained for this procedure so that gaskets in the lower parts of the tanks can be examined.
3. Verify the operation of the emergency stop switches. Start the machine with all personnel standing clear and push an emergency stop switch to verify that it stops the machine. Do this for each switch. The emergency stop switch stops the conveyor belt and the pumps, but the heaters remain on. If the emergency stop switch fails to stop the machine, then the wiring to the switch should be verified. If, according to the schematic, the switch is wired correctly, then it is most likely faulty and should be replaced. Immediately inform operating personnel of the defect and instruct them as to where other emergency stop switches are as well as the main stop switch on the front control panel.
4. Verify the operation of the door switches. Start the machine with all personnel standing clear and open each door one at a time to verify that the unit shuts off. Do this for all pre-wash, wash, and power rinse doors. The door switches stop the conveyor belt and the pumps, but the heaters remain on.



**WARNING!** *Hot water can drip as doors are opened.*

**WEEKLY  
MAINTENANCE**

5. Verify the pre-wash, wash, and power rinse doors open all of the way.
6. Verify the conveyor belt tension per the instructions given in the Belt Tension section of this manual.
7. Verify the operation of the temperature display. Operate the machine normally and ensure the display cycles as it is supposed to, through each required parameter. If it does not cycle or it appears that it's not reading the temperature, it must be replaced.
8. Verify the operation of Start and Stop buttons. With the machine energized, push the Start button on the control panel and allow the machine to start. After approximately 60 seconds, press the stop button. The machine should stop. Verify the lights in the buttons are working as well. Any problems should be investigated immediately to see if components need to be replaced. Perform this check on the buttons located at the load and unload ends as well.
9. Verify drive motor stop switch and slide stop switches.

**MONTHLY  
MAINTENANCE**

1. Inspect the drive gears for missing or damaged teeth. If there has been any sort of damage, the gear should be replaced immediately.
2. Inspect seals used in final rinse arms to ensure they are in good condition. Any that have nicks, tears, or are missing should be replaced.
3. Inspect the conveyor drive belt for damaged or missing pegs. Any that are suspect should be replaced. Loss of pegs decreases the number of dishes per hour that the machine will wash. Check rod end-caps and ensure that none are missing.
4. Visual inspection of electrical boxes. With power to the unit shut-off at the service breaker, open the main control box and the control boxes for each section and make a visual inspection of the components. Verify there are no loose wires, there is no carbon scoring, and that all components are secure. Replace the covers and re-energize the machine if no problems are found. Correct any deficiencies before returning the machine to an operating status.
5. Verify the conveyor operates in both high and low speeds. Start the machine as normal, ensuring that all personnel are clear. Put the machine in low speed using the Speed Selector Switch located on the front panel. Allow the machine to operate normally for five minutes, ensuring the speed appears to remain constant. Without turning off the machine, turn the switch to the high speed position and allow to run for another five minutes, checking for a constant speed. Once completed, place the selector switch in the desired position and turn the machine off.
6. Inspect the vacuum breakers to ensure the valve disc is not damaged, limed up, or misaligned. With power and water secured to the machine, verify the small disc inside the vacuum breakers move freely and seat well.
7. Inspect and clean the steam supply y-strainer on steam models.

**QUARTERLY  
MAINTENANCE**



1. Check the amperage draw for each connection point; this should be done only by qualified electricians since this involves working with energized components. Compare the amperage draw for each section to what is listed on the data plate and/or to maintenance records. Any significant change in amperage draw could be indicative of a major component (motor or heater) failing and should be investigated further to determine the exact cause of the change.
2. Verify the machine is maintaining proper temperatures as indicated on the machine data plate. Start the machine and allow it to run in low speed with the exhaust fan and blower turned on. Do not load any ware onto the machine. Let run for approximately 15 minutes before starting to observe temperatures. Compare the temperatures to what is listed on the machine data plate. If there is a discrepancy, investigate and correct.
3. Verify the machine is still level. A level machine is required for peak efficiency as water levels can be affected due to any incline. This should be done with the machine off, cooled down, and drained.
4. Delime the electric booster heater. In order to maintain the electric booster heater at its optimum performance level, lime and corrosion deposits must be removed on a frequent basis. To delime, refer to the instruction manual that came with the electric booster heater. A deliming solution should be available from your chemical supplier. Read and follow all instructions on the label of the deliming solution.

**ANNUAL  
MAINTENANCE**

1. The manufacturer recommends that at least once a year a general, overall inspection of the machine is performed. With the machine drained and power secured at the service breaker, service personnel should look for any items needing addressed that might not be specifically pointed out in the preventative maintenance procedures. Examples of things to look for include:
  - Loose screws.
  - Frayed wires.
  - Broken lights or switches.
  - Torn curtains.

**NOTICE** *Experience will dictate to service personnel specific items that should be examined and the manufacturer encourages scheduling inspections as often as needed to ensure any problems do not become catastrophic.*

**ITEMS THAT SHOULD NOT REQUIRE MAINTENANCE**

1. Thermostats - the thermostats are factory-set so the machine will operate in accordance with accepted regulatory parameters. Upon initial installation, the manufacturer's representative might adjust the thermostats if required, but otherwise they should never need to be corrected again. If thermostats need adjusted to maintain the same temperatures, there is most likely a problem somewhere else. Scale build-up in the tub and on the heaters can affect the operation of the machine as can a variety of other factors. Thermostats, once they fail, cannot be repaired and should be replaced.
2. Gear drive - the drive motor is connected to a gear drive that is oil-filled. The manufacturer does not recommend draining the gear drive for any reason. If the gear drive fails, then it should be replaced, not repaired. If for any reason the oil is drained from the gear drive, the component should be replaced.

---

**ITEMS OF NOTE**

1. The electric booster heater is a third-party, self-contained unit and should come with its own instruction manual. Refer to that manual for any information regarding troubleshooting or maintenance.
2. If the display indicates a motor fault, the machine must be shut down completely and service personnel contacted. A motor fault can be for any number of reasons and could apply to any one or more of the motors on the machine. Do not operate the machine if the display indicates a motor fault.

- PROGRAMMING** 1. Press and hold delime and start buttons until "SETUP USER" flashes. Display will then show first programmable parameter.

*To access programming, machine should be on and not in cycle.*

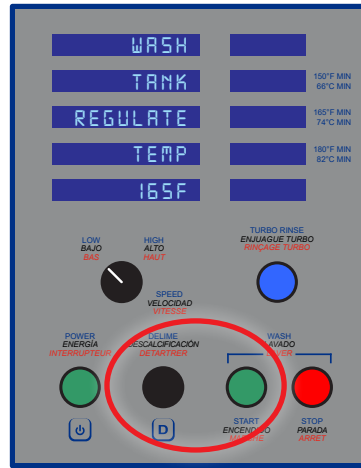

**PARAMETERS**

PARAMETER	MAX	MIN	PARAMETER	MAX	MIN
Wash Regulate Temperature	188 °F (87 °C)	140 °F (60 °C)	Dwell On Speed Change	500 Milliseconds	100 Milliseconds
Wash Low Temperature Alarm	188 °F (87 °C)	140 °F (60 °C)	Belt Prestart Delay	2 Minutes	0 Seconds
Power Rinse Regulate Temperature	188 °F (87 °C)	140 °F (60 °C)	Shutoff Load Disable Dwell	500 Milliseconds	100 Milliseconds
Power Rinse Low Temperature Alarm	188 °F (87 °C)	140 °F (60 °C)	Prewash (On is Default)	N/A	N/A
Final Rinse Low Temperature Alarm	188 °F (87 °C)	140 °F (60 °C)	Prewash Fill (On is Default)	N/A	N/A
Photo Eye Initial Wait	3 Minutes	5 Seconds	Prewash Fill Temperature	149 °F (65 °C)	99 °F (37 °C)
Photo Eye Restart Timeout	15 Minutes	0 Seconds	Full Conveyor Travel Duration	200 Seconds	30 Seconds
Photo Eye to Final Rinse On	5 Minutes	5 Seconds	Float Bounce Wait	20 Seconds	1 Second
Photo Eye To Rinse Shutoff	5 Minutes	5 Seconds	Temp Scale (°F is Default)	N/A	N/A
Conveyor Shutoff Restart Wait	5 Minutes	5 Seconds	Language (English is Default)	N/A	N/A
Conveyor Shutoff Idle Shutoff	5 Minutes	5 Seconds	PreWash Temperature Offset	3	-3
Delime Duration	30 Minutes	3 Minutes	Wash Temperature Offset	3	-3
Power Off Internal Fan	10 Minutes	0 Seconds	Power Rinse Temperature Offset	3	-3
Power Off External Fan	10 Minutes	0 Seconds	Final Rinse Temperature Offset	3	-3
Dryer Fan Delay	5 Minutes	0 Seconds	Spare T5 T6 Offset	3	-3
Reverse Belt Duration	2000 Milliseconds	250 Milliseconds	Dryer (On is Default)	N/A	N/A

2. Start and stop buttons act as "up-arrow" and "down-arrow" buttons to move through parameters.

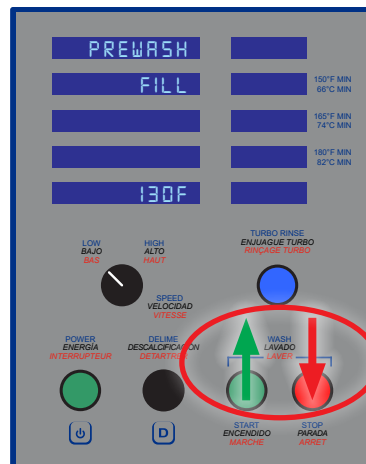

Firmly press and hold button for one second then release. Next programmable parameter will appear.

**PROGRAMMING** 3. Repeat until desired parameter is reached.

*To access programming, machine should be on and not in cycle.*

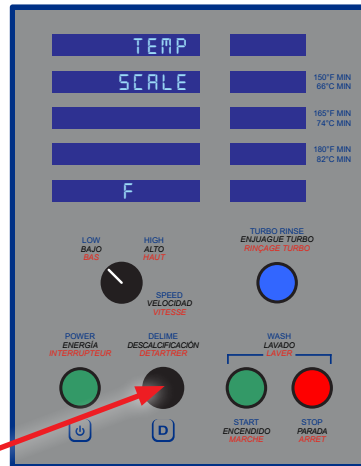

- 4. Press delime button until parameter value starts flashing.
- 5. Use start and stop buttons to change parameter to desired value.

*Firmly press and hold button for one second then release.*

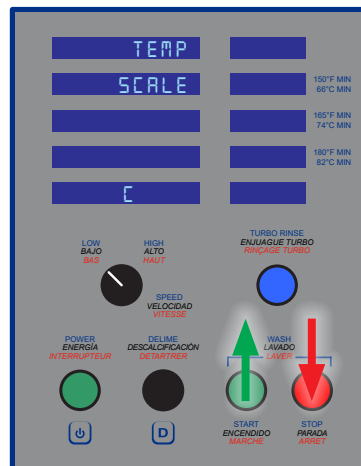

- 6. Press delime button to save.

*Firmly press and hold button for one second then release.*

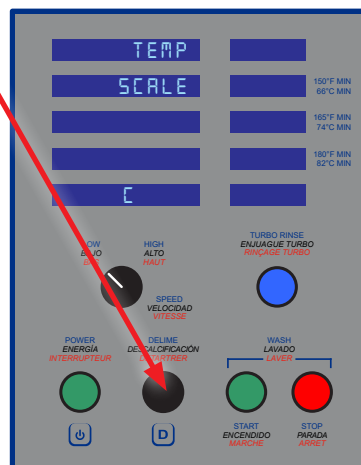

- 7. Press and hold delime and start buttons until display goes to operation mode.



**WARNING!** Inspection, testing, and repair of electrical equipment should only be performed by a qualified service technician. Many of the tests require that the unit have power to it and live electrical components be exposed. USE EXTREME CAUTION WHEN TESTING THE MACHINE.

OBSERVATION	POSSIBLE CAUSE	REMEDY
Nothing on machine operates. Machine is ON and the power indicator light is OFF.	<ol style="list-style-type: none"> <li>1. Machine is not wired correctly to incoming power source.</li> <li>2. Machine circuit breakers are tripped.</li> <li>3. Service breakers are tripped.</li> </ol>	<ol style="list-style-type: none"> <li>1. Have an electrician verify wiring.</li> <li>2. Reset the circuit breakers. If they trip again, contact an electrician to verify the machine amp draw.</li> <li>3. Reset the service breakers. If they trip again, contact an electrician to verify the machine amp draw.</li> </ol>
Machine will not fill. Machine is ON and the power indicator light is ON.	<ol style="list-style-type: none"> <li>1. No water supply to machine.</li> <li>2. Incoming water solenoid valve damaged/faulty.</li> <li>3. Water level indicators are giving a false reading.</li> </ol>	<ol style="list-style-type: none"> <li>1. Verify water lines have been connected to the machine.</li> <li>2. Verify the valve is operating. If not, replace.</li> <li>3. See if the green "Tank Filled" light is on. Verify the wiring of the water level indicators and if correct, replace component.</li> </ol>
Low wash tank/ power rinse tank temperature.	<ol style="list-style-type: none"> <li>1. Electric booster heater not energized.</li> <li>2. Low incoming water temperature.</li> <li>3. Heater not energizing.</li> <li>4. Low incoming voltage.</li> <li>5. Heater(s) has scale and lime build-up.</li> </ol>	<ol style="list-style-type: none"> <li>1. Verify electric booster heater is energized.</li> <li>2. Verify the incoming water temperature matches what is indicated on the machine data plate.</li> <li>3. Verify the wash tank heater is operating. If not, replace.</li> <li>4. Have an electrician verify the power coming to the machine is the same as indicated on the data plate.</li> <li>5. Try deliming the machine. If this does not correct the problem, the heater(s) should be replaced.</li> </ol>
Inadequate rinse.	<ol style="list-style-type: none"> <li>1. Low incoming water pressure.</li> <li>2. Incoming water solenoid is clogged.</li> <li>3. Final rinse pump not operating.</li> <li>4. Incoming water y-strainer is clogged.</li> <li>5. Clogged rinse arm nozzles.</li> </ol>	<ol style="list-style-type: none"> <li>1. Verify that incoming water pressure to rinse tank during fill is 15 PSI.</li> <li>2. Verify that debris is not trapped in valve. If so, remove debris.</li> <li>3. Replace pressure transducer.</li> <li>4. Remove debris from y-strainer.</li> <li>5. Verify nozzles are not clogged with debris. If so, remove debris.</li> </ol>

OBSERVATION	POSSIBLE CAUSE	REMEDY
<b>Ware is coming out dirty.</b>	<ol style="list-style-type: none"> <li>1. Improper pre-scapping procedures.</li> <li>2. Verify the chemical concentrations are correct.</li> <li>3. Wash pumps are clogged with debris.</li> <li>4. Water level is too low and pumps are cavitating (drawing in air).</li> <li>5. Strainers are clogged with debris.</li> <li>6. Pre-wash, wash, or power rinse nozzles are clogged.</li> </ol>	<ol style="list-style-type: none"> <li>1. Verify proper pre-scapping procedures are being followed.</li> <li>2. See the Detergent Control page in this manual. If there appears to be a problem with the chemicals, contact your chemical representative.</li> <li>3. Remove debris if pump is not permanently damaged.</li> <li>4. Verify water levels are correct by observing whether or not the "Tank Filled" light is illuminated. If so and problem continues, visually verify the water level is correct.</li> <li>5. Remove and clean strainers.</li> <li>6. Verify nozzles are not clogged with debris. If so, remove debris.</li> </ol>
<b>An excessive amount of vapor is exiting the machine through the load and/or unload ends.</b>	<ol style="list-style-type: none"> <li>1. Exhaust fan is turned off as well as the room ventilation.</li> <li>2. Incorrect placement of curtains within the machine.</li> <li>3. Water temperatures too hot.</li> <li>4. Incorrect damper positioning.</li> </ol>	<ol style="list-style-type: none"> <li>1. Ensure the exhaust fan is turned on as well as the room ventilation.</li> <li>2. Correct as necessary.</li> <li>3. Verify water temperatures and ensure they comply with what is marked on the machine data plate</li> <li>4. Check correct damper positioning in the electrical section.</li> </ol>
<b>Machine continues to fill and does not stop. Green "Tank Filled" light does not come on.</b>	<ol style="list-style-type: none"> <li>1. No water coming to the machine.</li> <li>2. Drain valves are open.</li> <li>3. Water level controls are faulty.</li> <li>4. Leak in the tank.</li> <li>5. Drain valve indicates closed but is not.</li> <li>6. Level control sensors out of adjustment.</li> </ol>	<ol style="list-style-type: none"> <li>1. Verify the power is on and the water supply is also turned on.</li> <li>2. Verify the position of the valves and shut if necessary.</li> <li>3. Verify the wiring of the water level controls to the schematic and if correct, replace.</li> <li>4. Inspect under the machine to verify there are no holes or cracks.</li> <li>5. Replace or repair the drain valve.</li> <li>6. Level control sensors might need the sensitivity adjusted.</li> </ol>

OBSERVATION	POSSIBLE CAUSE	REMEDY
<b>Water level will not remain constant (tanks appear to be losing water).</b>	<ol style="list-style-type: none"> <li>1. Drain valve is open and draining the tub.</li> <li>2. Low water pressure.</li> <li>3. Machine is not level.</li> <li>4. Faulty water level control or control probe.</li> <li>5. Check placement of splash shield run-offs.</li> <li>6. Check curtain placement.</li> </ol>	<ol style="list-style-type: none"> <li>1. Verify all drain valves are shut.</li> <li>2. Verify incoming water is flowing to the machine and at the pressure indicated on the data plate.</li> <li>3. Verify the machine is level.</li> <li>4. Replace as required.</li> <li>5. Adjust if necessary.</li> <li>6. Adjust if necessary.</li> </ol>
<b>Machine is running and suddenly stops. Motor fault light could be on.</b>	<ol style="list-style-type: none"> <li>1. Power might have been lost to the machine.</li> <li>2. Conveyor belt bound-up or jammed during operation.</li> <li>3. Conveyor drive chain is broken or has come off.</li> <li>4. Conveyor drive motor faulty.</li> <li>5. Failure of drive motor switch or slide stop switch.</li> </ol>	<ol style="list-style-type: none"> <li>1. If the control box lights are on, it is safe to assume there is power.</li> <li>2. Ensure there are no obvious jams or obstructions preventing the conveyor belt from moving. It might be necessary to remove all ware from the conveyor before proceeding. Try pulling up on the conveyor belt at various locations in the event it became misaligned. Be careful, this could cause the conveyor belt to snap back into place instantly! Another sign of a jammed belt is the conveyor drive motor will be pulled against the machine and its spring bracket will be compressed.</li> <li>3. Secure the machine and remove the cover to expose the drive motor, gearing, and chain. If the chain is broken, it might be possible to put it back together; otherwise a new one should be ordered.</li> <li>4. Chain or drive motor might need to be replaced.</li> <li>5. Replace switch.</li> </ol>
<b>Conveyor not running.</b>	<ol style="list-style-type: none"> <li>1. Faulty photoeye sensor.</li> </ol>	<ol style="list-style-type: none"> <li>1. Use override switch on pre-wash control box to override sensor until it can be replaced.</li> </ol>

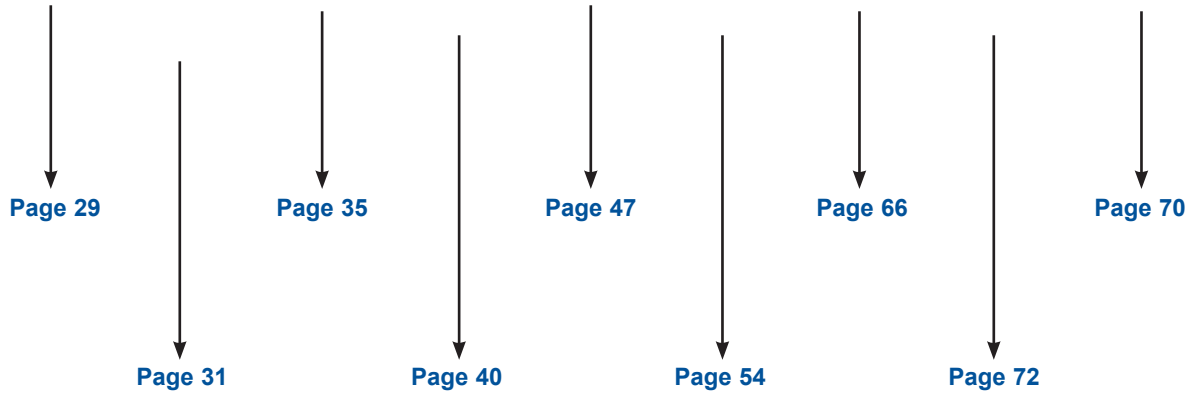
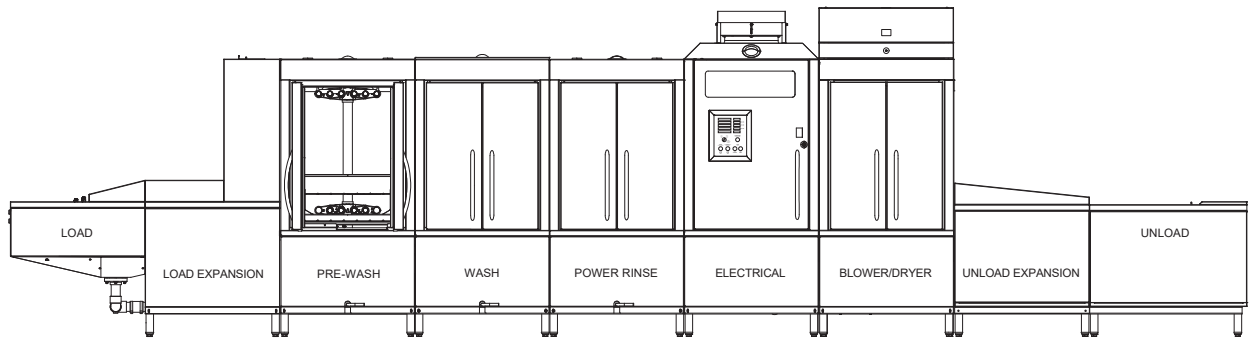

**NOTICE** L-R shown.

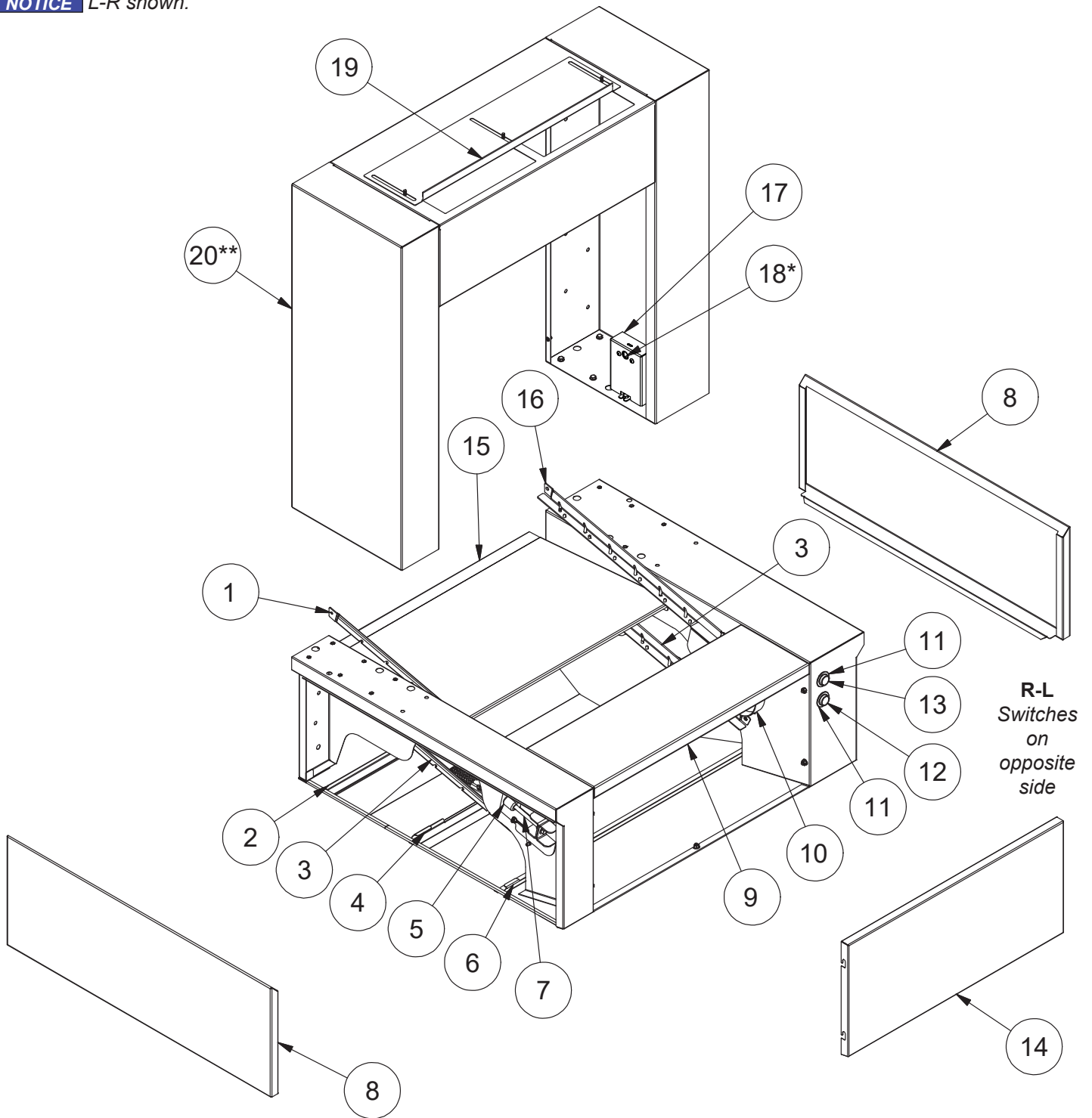

ITEM	QTY	DESCRIPTION	PART NUMBER
1	1	Upper Rail Two	05700-004-61-01
2	1	Screen Rail Three	05700-004-65-53
3	2	Lower Rail	05700-004-61-02
4	1	Screen Rail Two	05700-004-65-52
5	1	Adjuster, Conveyor, Left	05700-004-61-05
6	1	Screen Rail One	05700-004-65-51
7	2	Bolt, 3/8-16 x 5"	05700-003-52-34
8	2	Side Cover	05700-004-66-80
9	1	End Cover, Top	05700-004-66-79
10	1	Adjuster, Conveyor, Right	05700-004-61-08
11	2	Snap Bushing	05975-003-10-46
12	1	Stop Switch	05930-004-72-99
13	1	Start Switch	05930-004-72-98
14	1	End Cover	05700-004-66-78
15	1	Runoff	05700-004-61-18
16	1	Upper Rail One	05700-004-61-03
17	2	Optical Cover	05700-005-06-03
	2	Bracket, Optical Cover (Not Shown)	05700-005-05-98
18*	2	Sensor	06401-005-06-02*
19	1	Damper	05700-004-72-59
20**	1	Shroud, L-R	05700-004-60-85
		Complete Shroud Assembly, L-R (Items 17–20)	05700-004-78-18
		Shroud, R-L	05700-004-76-28
		Complete Shroud Assembly, R-L (Items 17–20)	05700-004-79-82

\*Order 06401-005-05-97 for machines with serial numbers before 22G407712.

\*\*If Load Expansion is used, Shroud is located on expansion section.

**NOTICE** L-R shown.

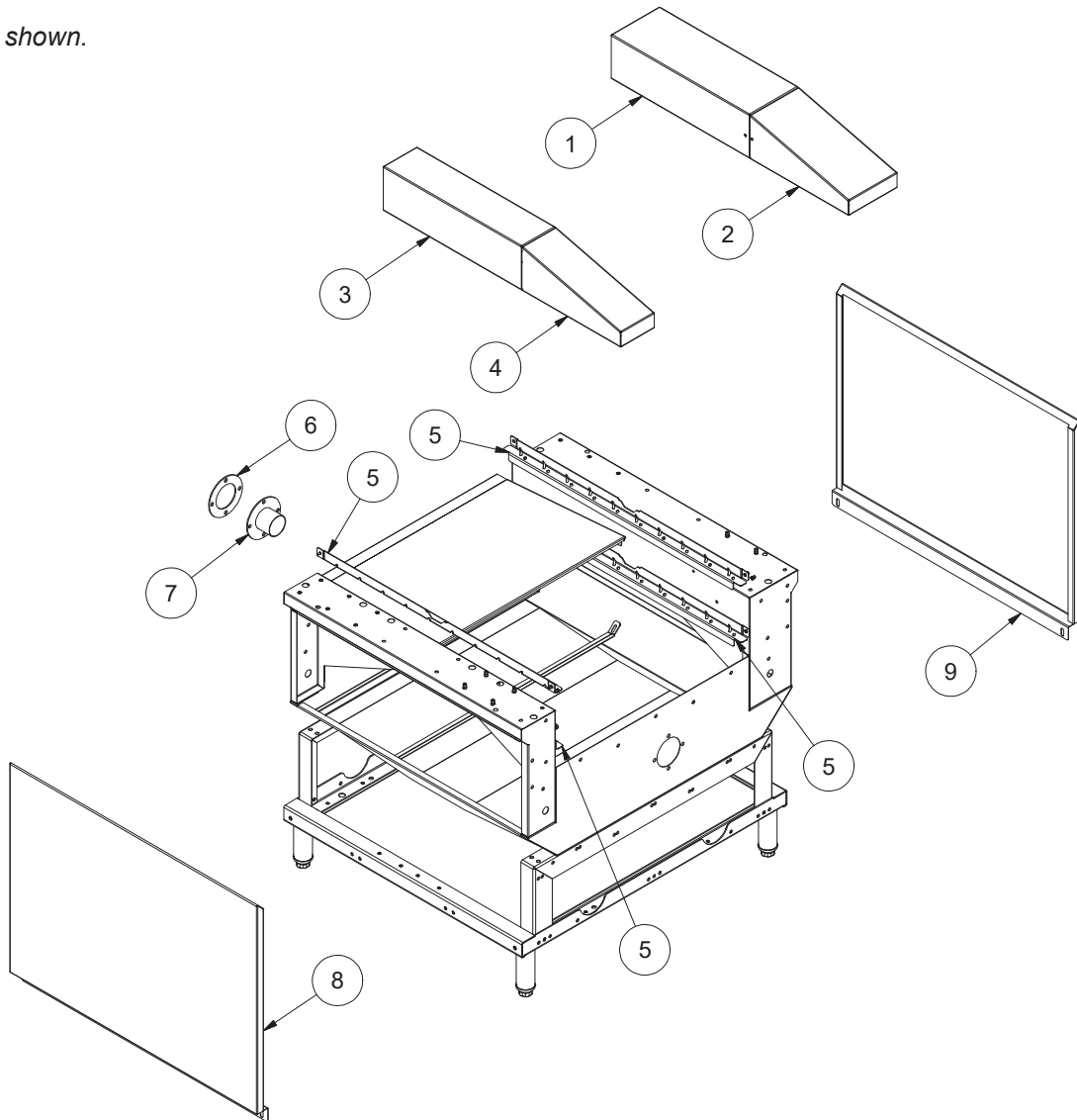

ITEM	QTY	DESCRIPTION	PART NUMBER
1	1	Riser, Load Expansion, L-R Riser, Load Expansion, R-L	05700-004-81-70 05700-004-81-94
2	1	Riser, Taper, Load Expansion, L-R Riser, Taper, Load Expansion, R-L	05700-004-81-82 05700-004-82-01
3	1	Riser, Load Expansion, L-R Riser, Load Expansion, R-L	05700-004-81-72 05700-004-81-92
4	1	Riser, Taper, Load Expansion, L-R Riser, Taper, Load Expansion, R-L	05700-004-81-84 05700-004-81-99
5	4	Conveyor Rail	05700-004-62-24

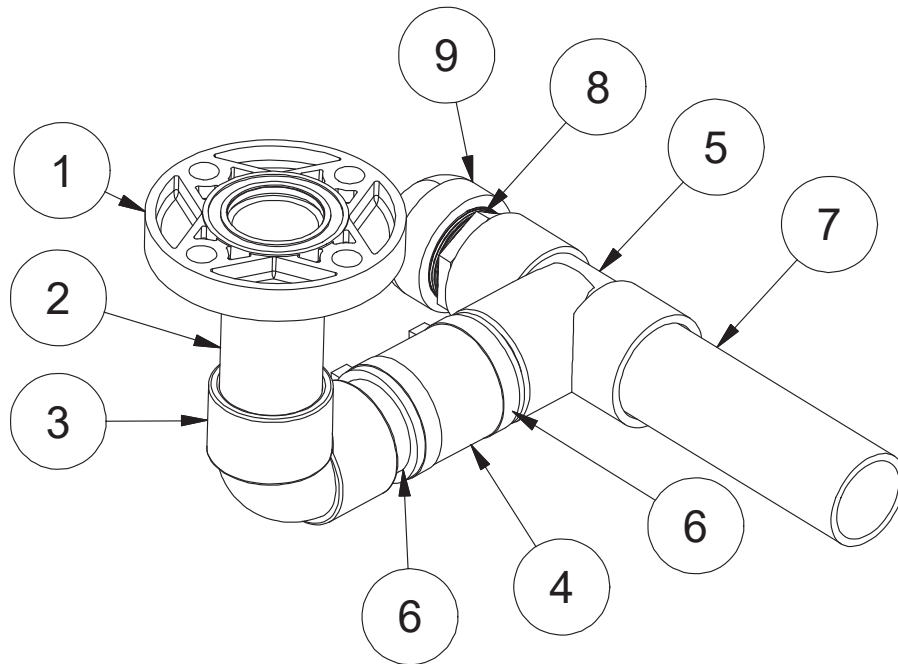

ITEM	QTY	DESCRIPTION	PART NUMBER
1	1	Flange, 2"	04730-003-04-25
2	1	Tube, CPVC 2" x 6"	05700-003-05-00
3	1	Elbow, 90-degree, CPVC, 2"	04730-002-72-25
4	1	No Hub Connector, 2"	04730-002-66-87
5	1	Tee, CPVC, 2"	04730-002-66-09
6	2	Tube, CPVC 2"	05700-004-61-21
7	1	Tube, CPVC 2"	05700-004-65-47
8	1	Adapter, 2" x 2"	04730-004-72-64
9	1	Fitting, Cap 2"	04730-004-72-65
10	1	Drain Gasket, 2" (Not Shown)	05330-003-04-26

Complete Load Section Drain Plumbing  
 L-R 05700-004-67-31  
 R-L 05700-004-76-31

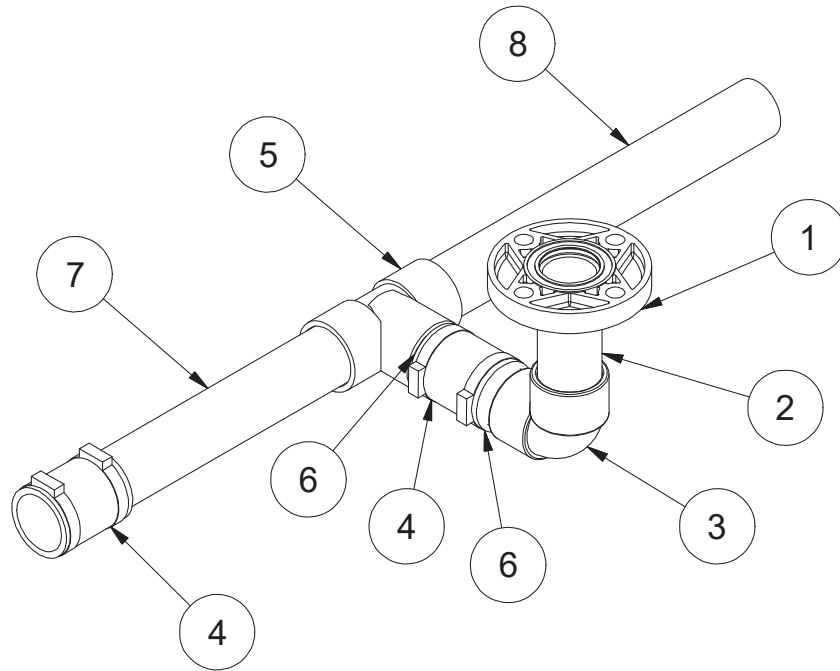

ITEM	QTY	DESCRIPTION	PART NUMBER
1	1	Flange, 2"	04730-003-04-25
2	1	Tube, CPVC 2" x 6"	05700-003-05-00
3	1	Elbow, 90-degree, CPVC, 2"	04730-002-72-25
4	2	No Hub Connector, 2"	04730-002-66-87
5	1	Tee, CPVC, 2"	04730-002-66-09
6	2	Tube, CPVC 2"	05700-004-61-21
7	1	Tube, CPVC 2" x 14 3/4"	05700-004-81-86
8	1	Tube, CPVC 2" x 18 3/4"	05700-004-81-87

Complete Load Expansion Drain Plumbing  
05700-004-81-88

When ordering replacement conveyor belt assemblies, please have machine serial number available and contact technical support toll free at 888.800.5672.

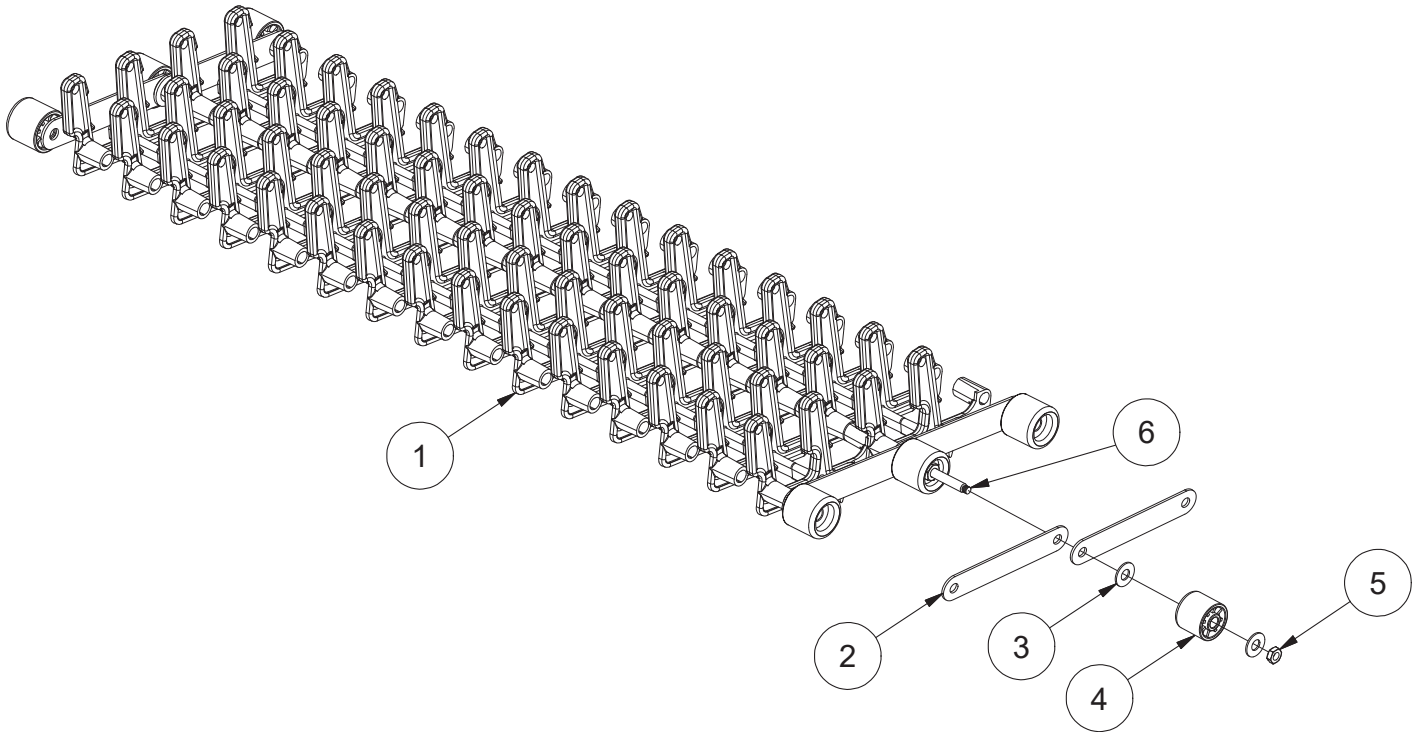

ITEM	QTY	DESCRIPTION	PART NUMBER
	1	Complete 12' Rod Assembly	05700-002-85-37
1	15	Peg, Belt	05700-003-25-80
2	2	Plate, Connector	05700-002-63-85
3	6	Washer	05311-175-01-00
4	2	Wheel, PVC	05340-002-63-86
5	2	Locknut, 1/4-20, Low Profile with Nylon Insert	05310-374-02-00
6	1	Rod, Conveyor	05700-002-63-92

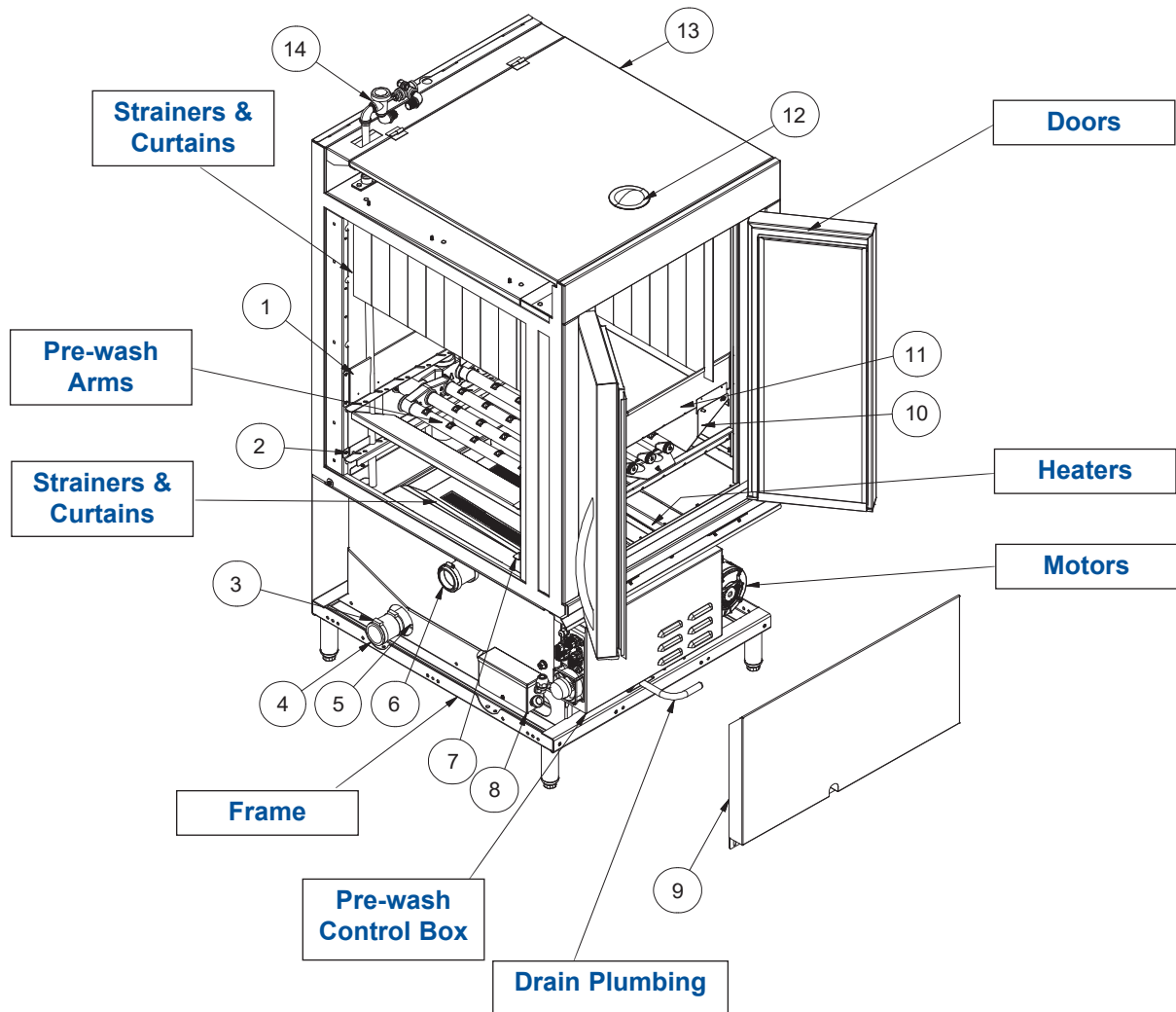

ITEM	QTY	DESCRIPTION	PART NUMBER
1	2	Rail, Conveyor Upper	05700-004-71-99
2	1	Rail, Conveyor Lower, Rear	05700-004-62-24
3	4	Hose Clamp, 2 9/16" to 3 1/2"	04730-003-15-40
4	1	Connector, 2" No Hub	04730-002-66-87
5	2	Tube, CVPC, 2"	05700-004-66-94
6	1	Hose, 2 1/2" ID, Blue, 10" Long	05700-004-67-02
7	1	Rail, Conveyor Lower	05700-004-62-05
8	1	Junction Box, Pre-wash to Load	05700-004-73-84
9	1	Panel, Front	05700-004-61-90
10	2	Baffle, Wash Diverter	05700-004-72-00
11	1	Rail, Conveyor Upper, Front	05700-004-71-98
12	1	Handle, Top	05700-002-67-21
13	1	Panel, Vent	05700-004-61-68
14	1	Plumbing, Fill Assembly	05700-004-72-60

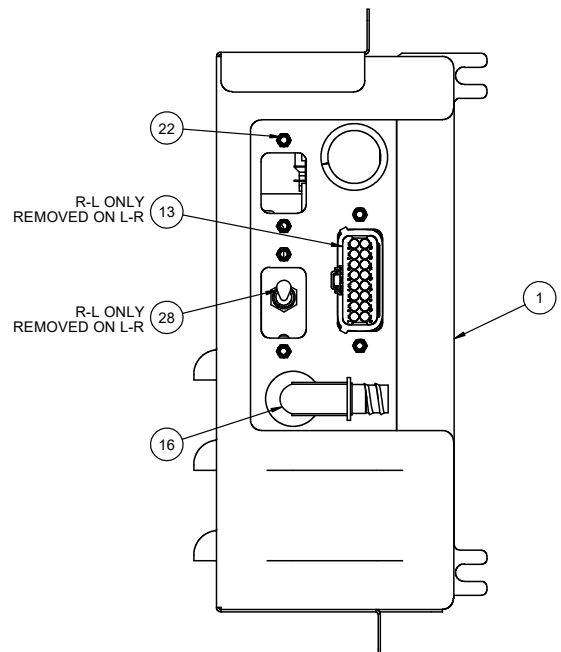
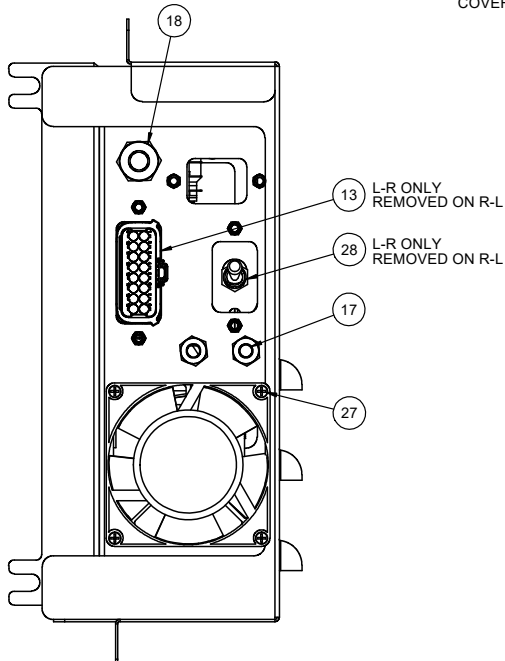
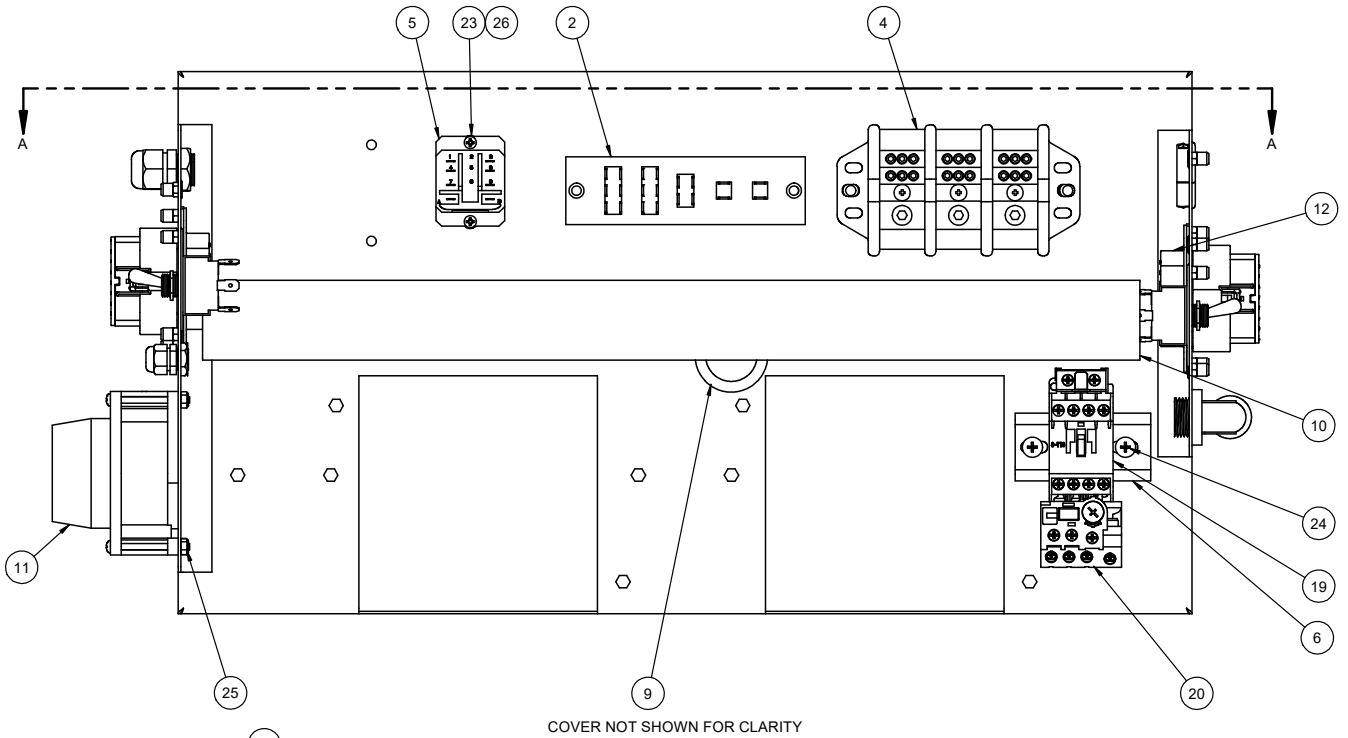
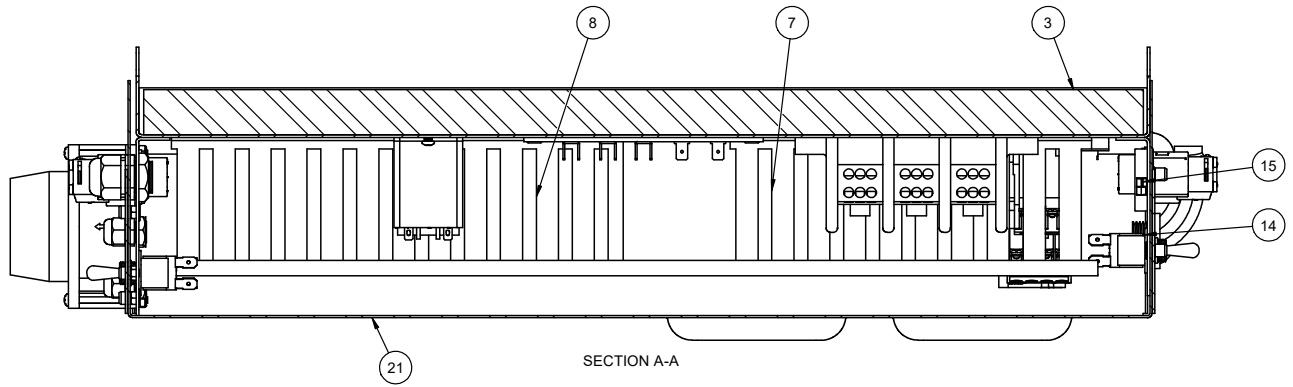

ITEM	QTY	DESCRIPTION	PART NUMBER
1	1	Control Box	05700-004-73-68
2	1	Terminal Board	05940-002-78-97
3	1	Foam Insulation, Lower Tub	05700-004-75-55
4	1	Terminal Block, 3-pole	05940-011-48-27
5	1	Relay, 2-Pole	05945-111-35-19
6	1	Din-rail, 3"	05700-011-84-65
7	1	Panduit Bottom, 1 1/2" x 3" x 8"	05700-004-65-18
8	1	Panduit Bottom, 1 1/2" x 3" x 10"	05700-004-65-17
9	1	Bushing, Snap	05975-003-10-46
10	1	Panduit Top, 1 1/2" x 20 3/4"	05700-002-87-24
11	1	Fan	05999-004-19-46
12	2	Connector, 16-pin Mount	05940-004-73-27
13	2	Connector, 16-pin Receptacle	05940-004-73-43
14	2	Cover, Connector Hole, 8-pin	05940-004-73-47
15	1	Connector, 10-pin Receptacle	05975-004-35-29
16	1	Connector, 16-pin Receptacle	05975-003-35-32
17	2	Fitting, Nut and Cap	05975-205-43-00
18	1	Fitting	05975-011-49-03
19	1	Contact, AC, 100 V	05945-004-25-78
20	1	Overload	See Motor Overloads page.
21	2	Cover, Control Box	05700-004-74-07
22	22	Nut, Hex 10-32	05310-004-40-48
23	2	Nut, 10-32	05340-118-05-00
24	6	Screw, 10-32 x 3/4"	05305-011-62-17
25	4	Locknut, 6-32 x 1/2" with Nylon Insert	05310-373-03-00
26	2	Screw, 6-32 x 1/2"	05305-004-23-63
27	4	Screw, 6-32 x 1 3/4"	05305-004-36-67
28	2	Switch, Photoeye Override	05700-005-05-89

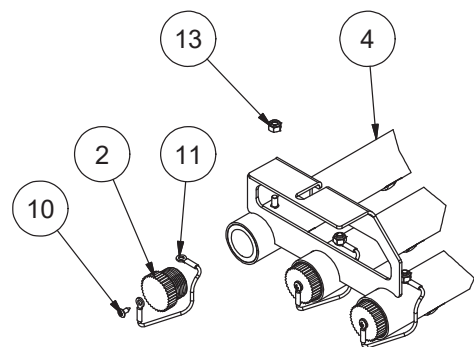
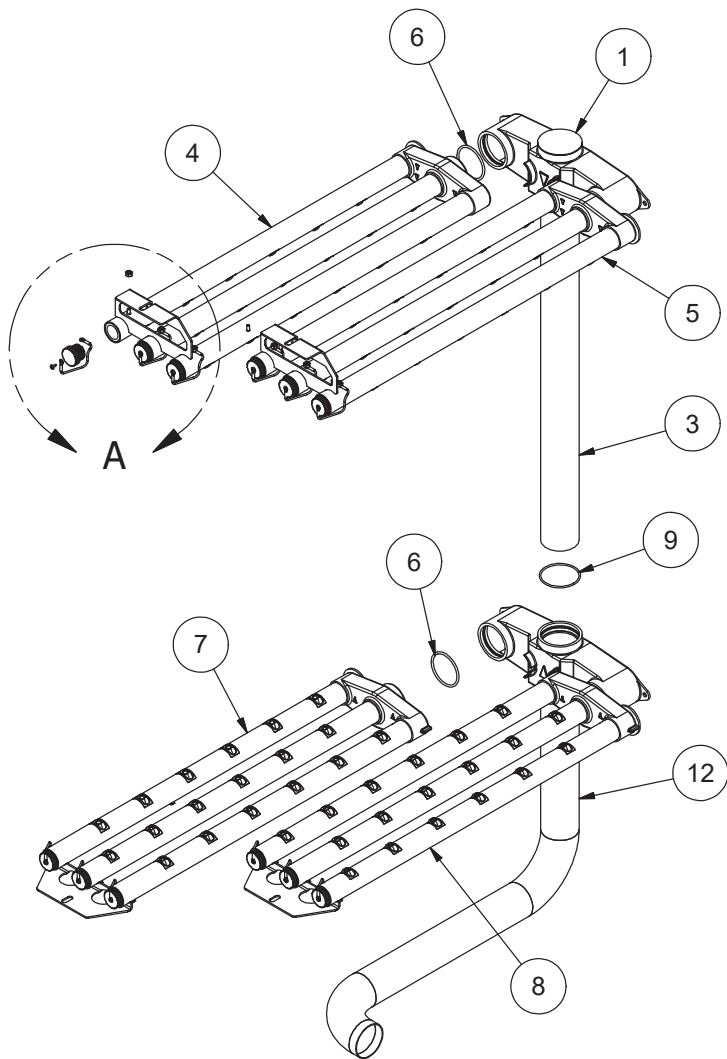

DETAIL A

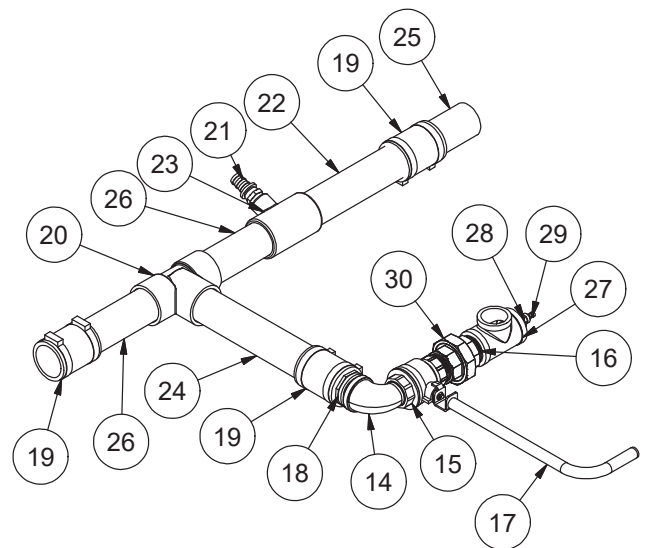

ITEM	QTY	DESCRIPTION	PART NUMBER
1	1	Wash Manifold, Upper	05700-003-73-66
2	12	Cap, Threaded	04730-603-12-00
3	1	Tube, Wash System Riser	05700-004-57-20
4	1	Wash Manifold, Upper Left	05700-004-57-22
5	1	Wash Manifold, Upper Right	05700-004-57-21
6	4	O-ring, 2 1/2"	05330-003-73-72
7	1	Wash Manifold, Lower Left	05700-004-57-24
8	1	Wash Manifold, Lower Right	05700-004-57-23
9	2	O-ring, 2 11/16"	05330-003-73-71
10	12	Screw, 6-40 x 3/8"	05305-002-63-49
11	12	Lanyard, 6"	05340-011-72-46
12	1	Wash Pump Manifold	05700-004-63-71
13	12	Locknut, 10-32 with Nylon Insert	05310-373-02-00
14	1	Elbow, 1 1/2" Brass, 90-degree	04730-206-32-00
15	1	Valve, Ball 1 1/2"	04820-111-71-46
16	2	Nipple, 1 1/2" Brass	04730-207-40-00
17	1	Drain Handle	05700-004-62-26
18	1	Fitting, 1 1/2"	04730-002-74-06
19	3	Connector, 2" No Hub	04730-002-66-87
20	1	Tee, 2"	04730-002-66-09
21	1	Fitting	04730-004-52-94
22	1	Tube, CVPC, 2" x 10 1/2"	05700-004-73-98
23	1	Reducing Tee	04730-004-63-80
24	1	Tube, CVPC, 2" x 11 1/2"	05700-004-64-38
25	1	Tube, CVPC, 2", Drain Right Side	05700-004-64-39
26	2	Tube, CVPC, 2", Drain Left Side	05700-004-66-94
27	1	Tee, 1 1/2"	04730-011-69-93
28	1	Reducer, 1 1/2" to 1/4"	04730-002-55-76
29	1	Fitting, 1/4"	04730-011-95-41
30	1	Union, 1 1/2"	04730-212-08-34

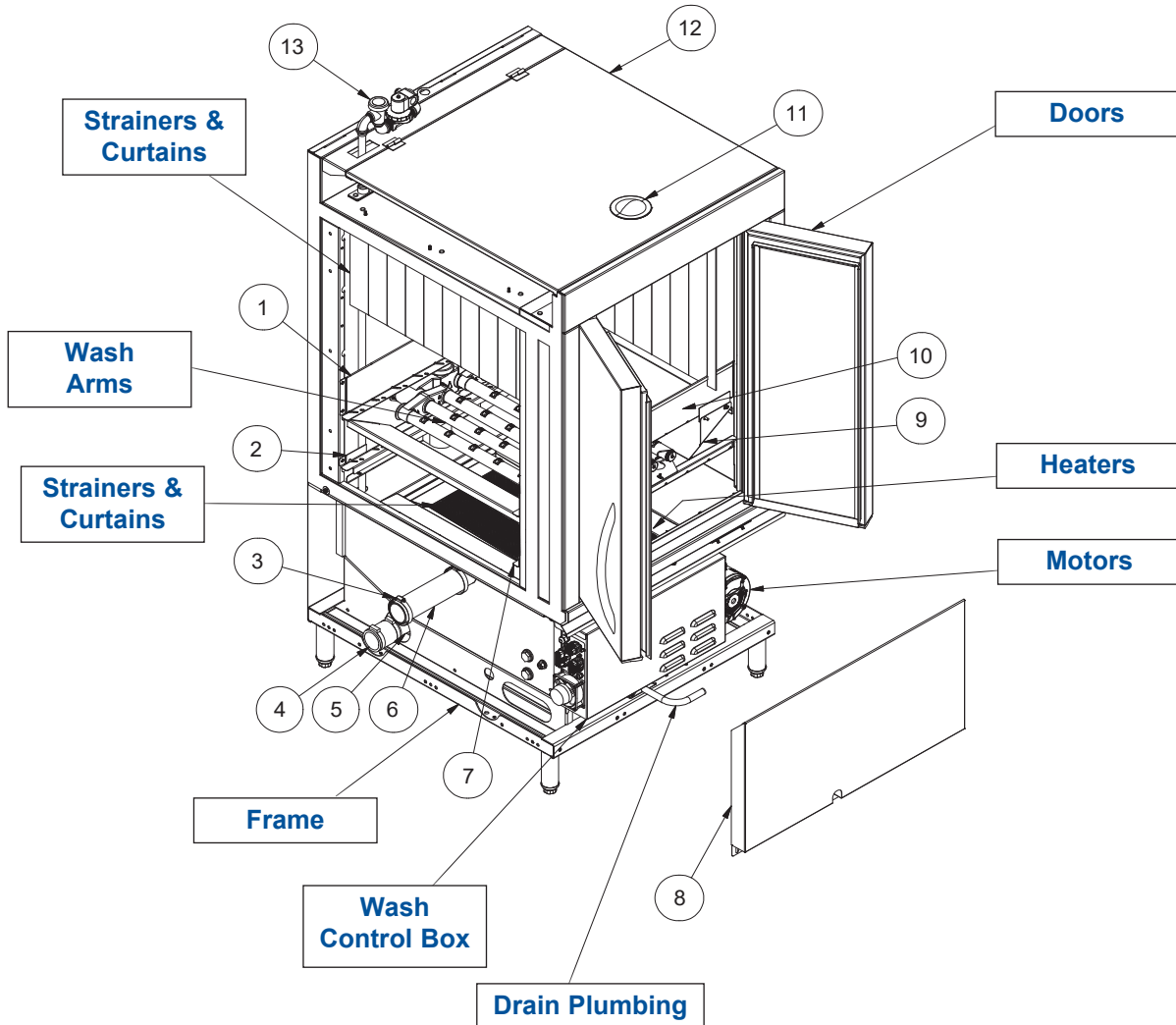

ITEM	QTY	DESCRIPTION	PART NUMBER
1	2	Rail, Conveyor Upper	05700-004-71-99
2	1	Rail, Conveyor Lower, Rear	05700-004-62-24
3	4	Hose Clamp, 2 9/19" to 3 1/2"	04730-003-15-40
4	1	Connector, 2" No Hub	04730-002-66-87
5	2	Tube, CVPC, 2"	05700-004-66-94
6	1	Hose, 2 1/2" ID, Blue, 10" Long	05700-004-72-48
7	1	Rail, Conveyor Lower	05700-004-62-05
8	1	Panel, Front	05700-004-61-90
9	2	Baffle, Wash Diverter	05700-004-72-00
10	1	Rail, Conveyor Upper, Front	05700-004-71-98
11	1	Handle, Top	05700-002-67-21
12	1	Panel, Vent	05700-004-61-68
13	1	Plumbing, Fill Assembly	05700-004-72-60

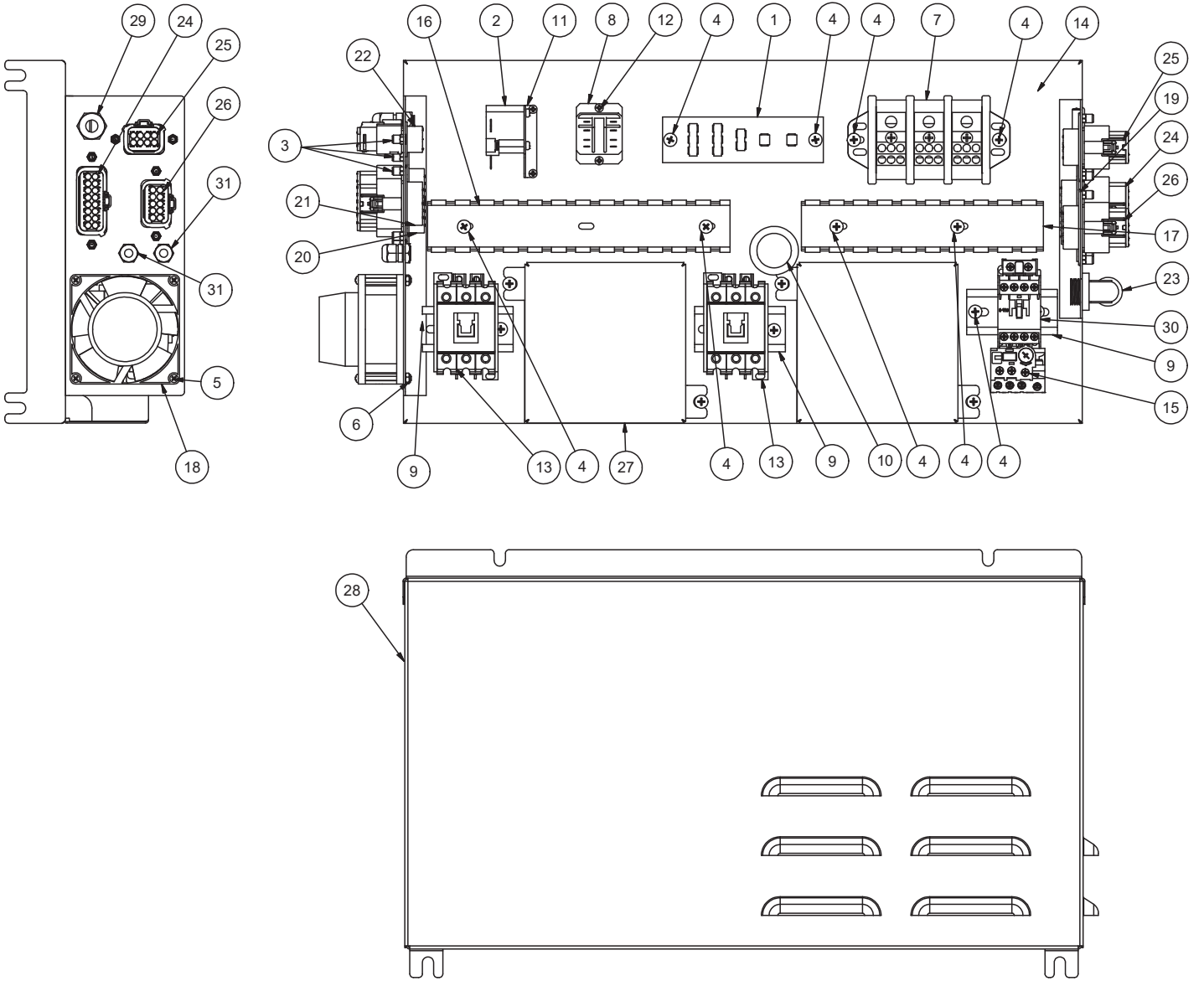

ITEM	QTY	DESCRIPTION	PART NUMBER
1	1	Terminal Board	05940-002-78-97
2	1	Thermostat	05930-004-33-12
3	30	Nut, Hex 10-32	05310-004-40-48
4	18	Screw, 10-32 x 3/4"	05305-011-62-17
5	4	Screw, 6-32 x 1 3/4"	05305-004-36-67
6	4	Locknut, 6-32 x 1/2" with Nylon Insert	05310-373-03-00
7	1	Terminal Block, 3-pole	05940-011-48-27
8	1	Relay, 2-Pole	05945-111-35-19
9	3	Din-rail, 3"	05700-011-84-65
10	1	Bushing, Snap	05975-003-10-46
11	1	Bracket, Thermostat	05700-004-36-37
12	4	Nut, 6-32 Plated	05340-118-04-00
	4	Screw, 6-32 x 1/2"	05305-004-23-63
13	1	Contactor, AC, 120 V	05945-002-65-98
14	1	Foam Insulation (Back of Box, Not Shown)	05700-004-61-45
15	1	Overload	See Motor Overloads page.
16	1	Panduit Bottom, 1 1/2" x 3" x 10"	05700-004-65-17
17	1	Panduit Bottom, 1 1/2" x 3" x 8"	05700-004-65-18
18	1	Fan	05999-004-19-46
19	1	Control Box	05700-004-73-68
20	2	Connector, 16-pin Mount	05940-004-73-27
21	2	Connector, 10-pin Mount	05940-004-73-28
22	2	Connector, 8-pin Mount	05940-004-73-29
23	1	Fitting, 1/2", 90-degree	05975-003-35-32
24	2	Connector, 16-pin Receptacle	05940-004-73-43
25	2	Connector, 8-pin Receptacle	05940-004-73-44
26	2	Connector, 10-pin Receptacle	05940-004-73-45
27	2	Cover, Heater	05700-004-73-71
28	1	Cover, Control Box	05700-004-74-07
29	1	Fitting	05975-011-49-03
30	1	Contactor, AC, 100 V	05945-004-25-78
31	2	Fitting, Nut and Cap	05975-205-43-00

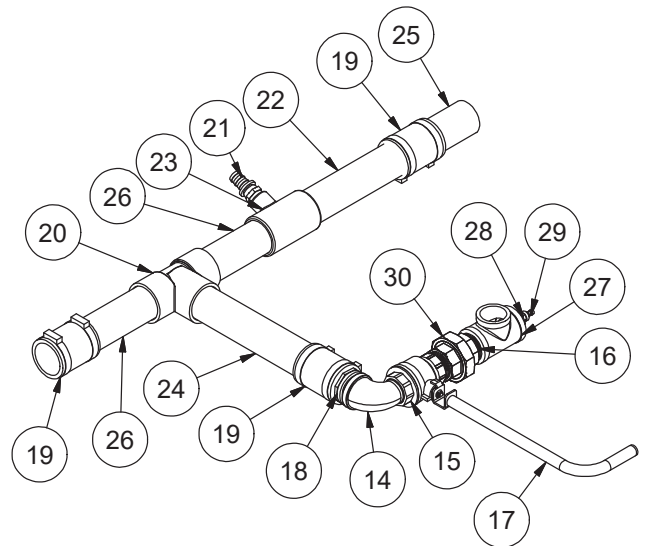
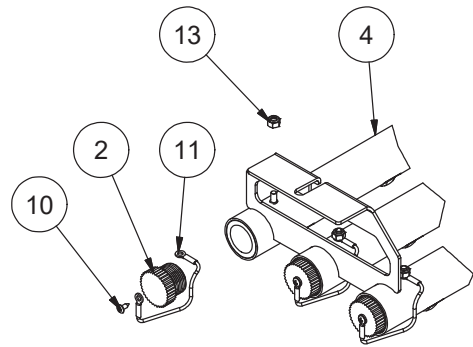
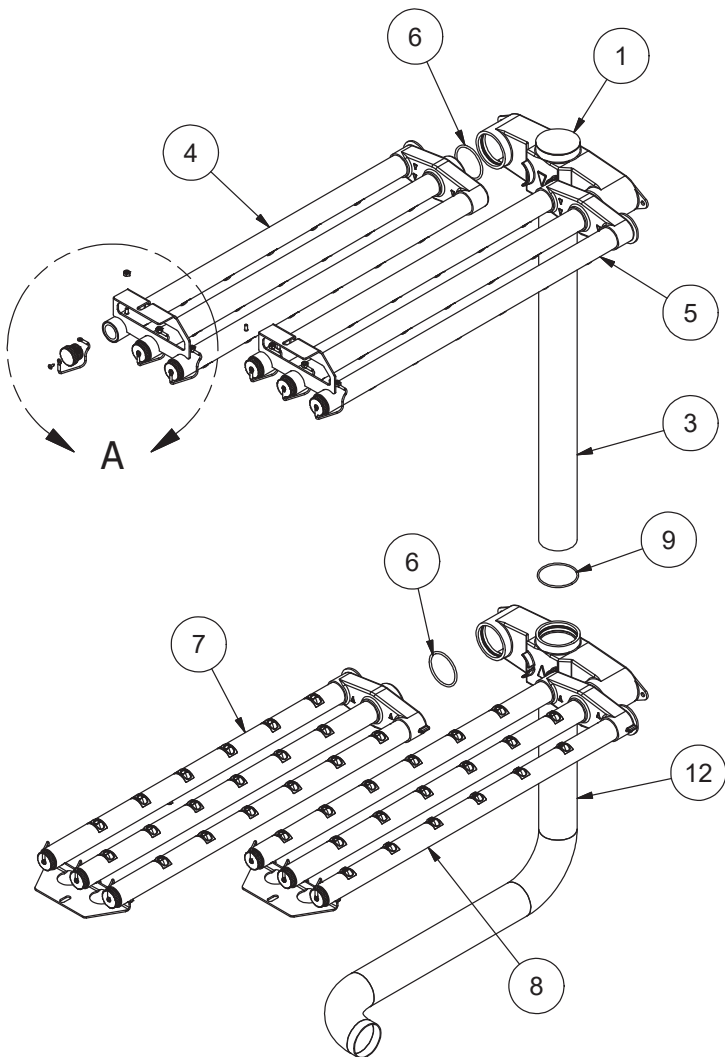

ITEM	QTY	DESCRIPTION	PART NUMBER
1	1	Wash Manifold, Upper	05700-003-73-66
2	12	Cap, Threaded	04730-603-12-00
3	1	Tube, Wash System Riser	05700-004-57-20
4	1	Wash Manifold, Upper Left	05700-004-57-22
5	1	Wash Manifold, Upper Right	05700-004-57-21
6	4	O-ring, 2 1/2"	05330-003-73-72
7	1	Wash Manifold, Lower Left	05700-004-57-24
8	1	Wash Manifold, Lower Right	05700-004-57-23
9	2	O-ring, 2 11/16"	05330-003-73-71
10	12	Screw, 6-40 x 3/8"	05305-002-63-49
11	12	Lanyard, 6"	05340-011-72-46
12	1	Wash Pump Manifold	05700-004-63-71
13	12	Locknut, 10-32 with Nylon Insert	05310-373-02-00
14	1	Elbow, 1 1/2" Brass, 90-degree	04730-206-32-00
15	1	Valve, Ball 1 1/2"	04820-111-71-46
16	2	Nipple, 1 1/2" Brass	04730-207-40-00
17	1	Drain Handle	05700-004-62-26
18	1	Fitting, 1 1/2"	04730-002-74-06
19	3	Connector, 2" No Hub	04730-002-66-87
20	1	Tee, 2"	04730-002-66-09
21	1	Fitting	04730-004-52-94
22	1	Tube, CVPC, 2" x 10 1/2"	05700-004-73-98
23	1	Reducing Tee	04730-004-63-80
24	1	Tube, CVPC, 2" x 11 1/2"	05700-004-64-38
25	1	Tube, CVPC, 2", Drain Right Side	05700-004-64-39
26	2	Tube, CVPC, 2", Drain Left Side	05700-004-66-94
27	1	Tee, 1 1/2"	04730-011-69-93
28	1	Reducer, 1 1/2" to 1/4"	04730-002-55-76
29	1	Fitting, 1/4"	04730-011-95-41
30	1	Union, 1 1/2"	04730-212-08-34

# PARTS

# WASH STEAM COIL & PLUMBING, L-R

**NOTICE** This steam coil assembly is used only in the FlightStar Steam Wash Section, L-R.

Complete Wash Section  
Steam Coil & Plumbing  
Assembly, L-R  
05700-004-79-97

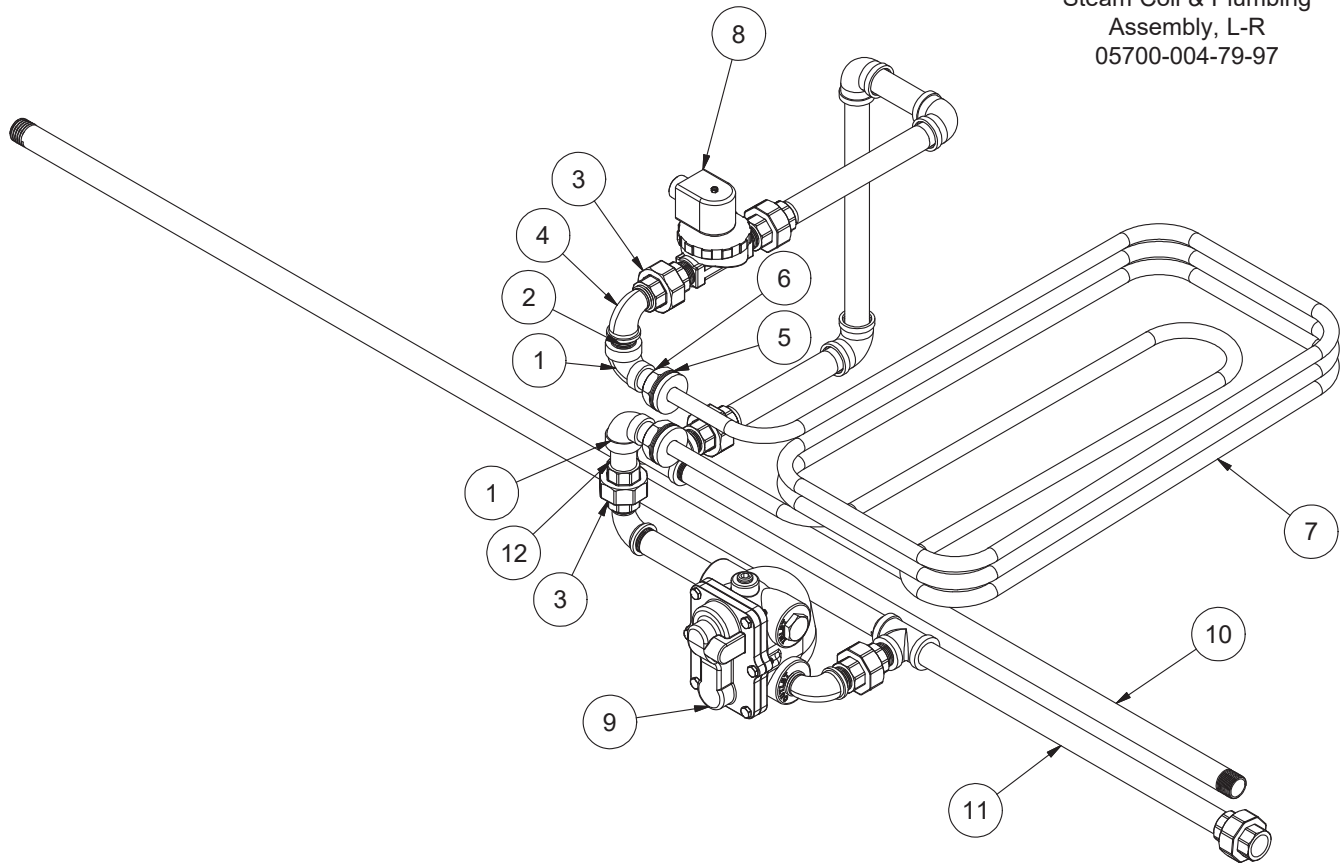

ITEM	QTY	DESCRIPTION	PART NUMBER
1	2	Elbow, 3/4" x 1/2" Black Iron	04730-003-75-92
2	6	Nipple, 3/4" Close Black Iron	04730-907-01-00
3	6	Union, 3/4" Black Iron	04730-912-01-00
4	3	Elbow, 90-degree, 3/4"	04730-011-87-37
5	4	Gasket, Steam Coil	05700-001-17-86
6	2	Nut, Steam Coil Adapter	05310-011-17-85
7	1	Steam Coil Assembly	05700-004-79-87
8	1	Steam Valve Piping Assembly Solenoid Valve Only	05700-004-79-81 04820-011-87-39
9	1	Steam Trap Assembly	05700-004-79-93
10	1	Steam Piping Assembly One	05700-004-79-95
11	1	Steam Piping Assembly Two	05700-004-79-96
12	1	Nipple, 3/4" x 2" Black Iron	04730-004-85-28

# PARTS

# WASH STEAM COIL & PLUMBING, R-L

**NOTICE** This steam coil assembly is used only in the FlightStar Steam Wash Section, R-L.

Complete Wash Section  
Steam Coil & Plumbing  
Assembly, R-L  
05700-004-86-90

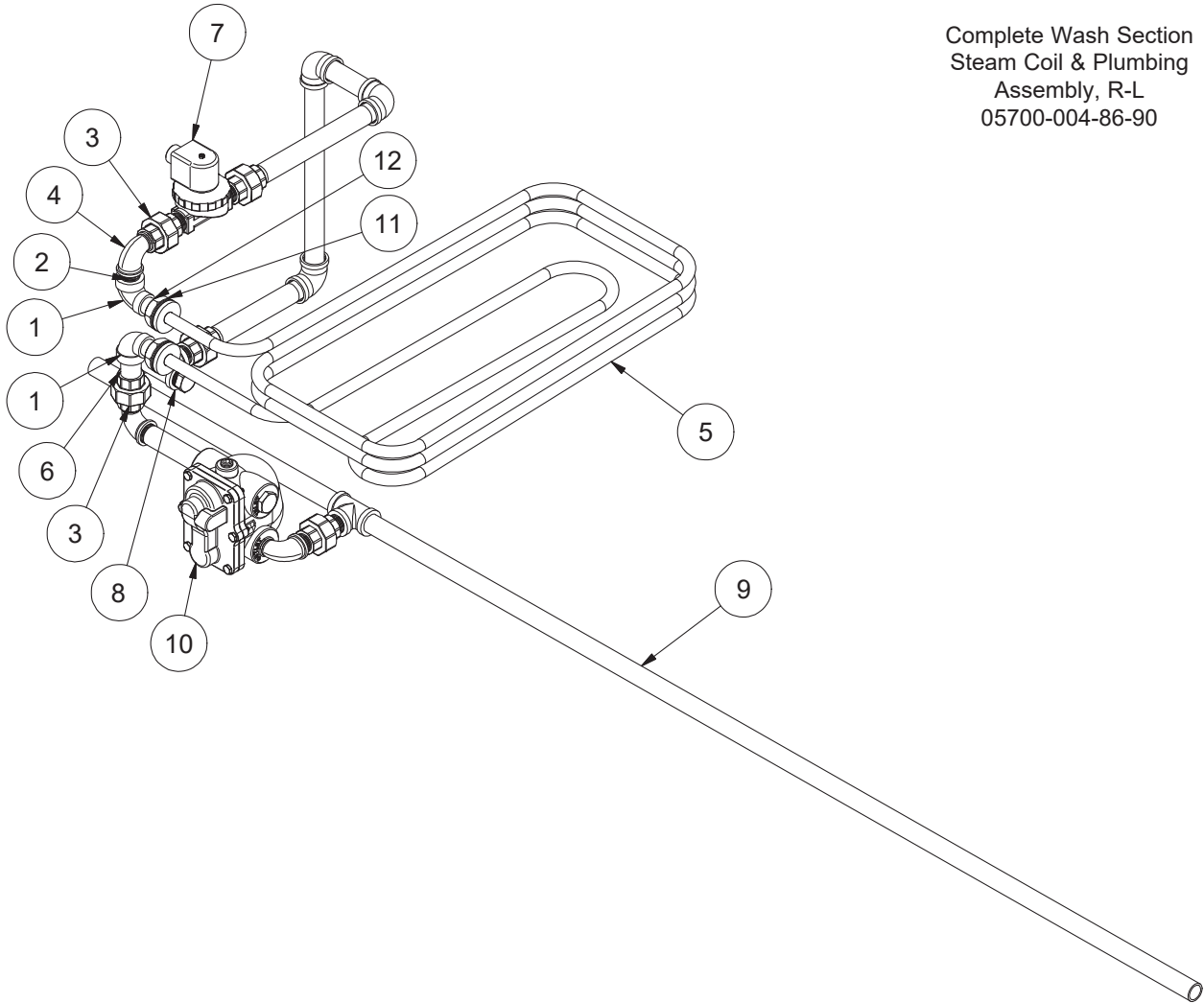

ITEM	QTY	DESCRIPTION	PART NUMBER
1	2	Elbow, 3/4" x 1/2" Black Iron	04730-003-75-92
2	6	Nipple, 3/4" Close Black Iron	04730-907-01-00
3	5	Union, 3/4" Black Iron	04730-912-01-00
4	3	Elbow, 90-degree, 3/4"	04730-011-87-37
5	1	Steam Coil Assembly	05700-004-79-87
6	1	Nipple, 3/4" x 2" Black Iron	04730-004-85-28
7	1	Steam Valve Piping Assembly Solenoid Valve Only	05700-004-79-81 04820-011-87-39
8	1	Steam Piping Assembly One	05700-004-86-91
9	1	Steam Piping Assembly Two	05700-004-86-92
10	1	Steam Trap Assembly	05700-004-86-93
11	4	Gasket, Steam Coil	05700-001-17-86
12	2	Nut, Steam Coil Adapter	05310-011-17-85

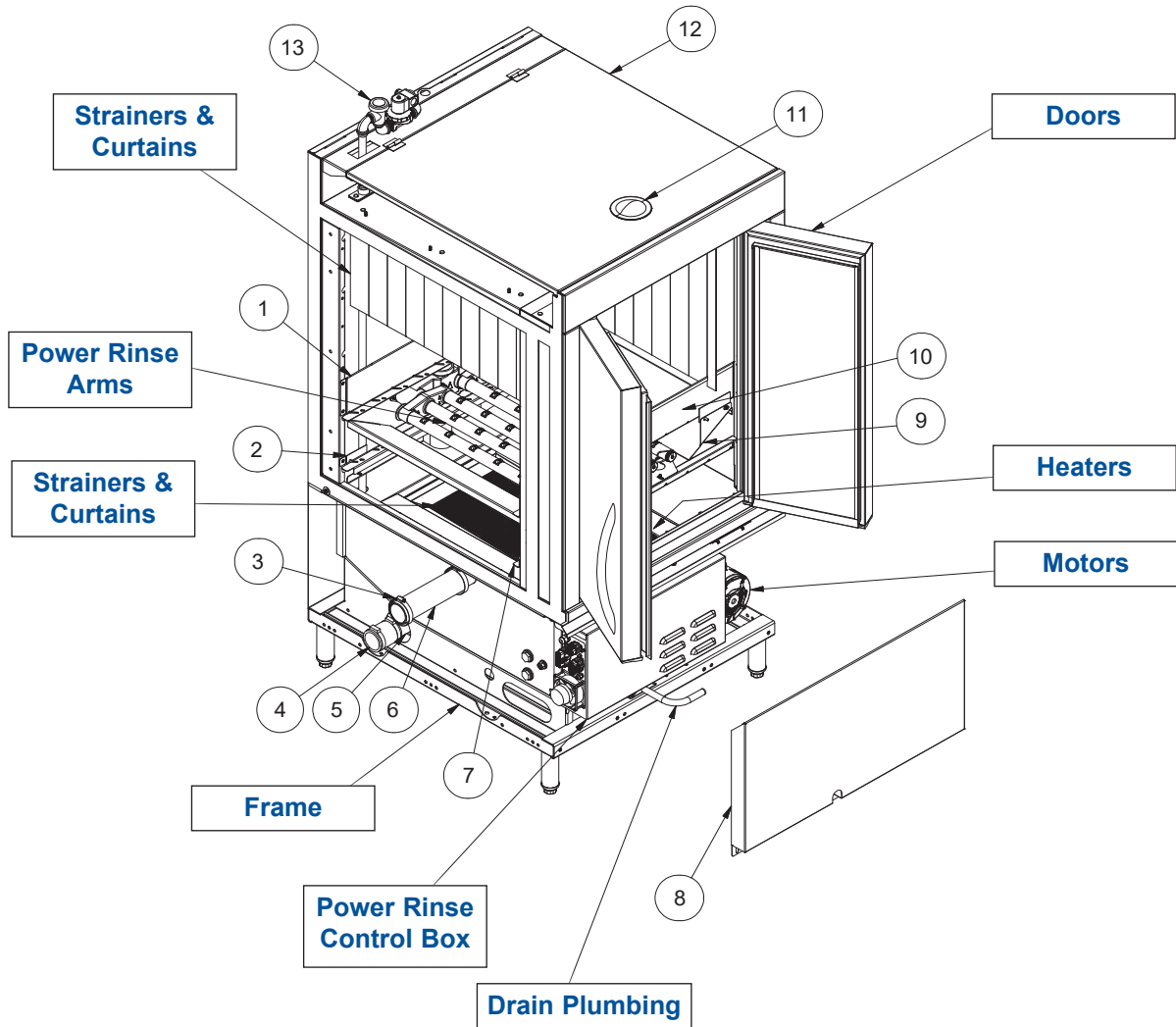

ITEM	QTY	DESCRIPTION	PART NUMBER
1	2	Rail, Conveyor Upper	05700-004-71-99
2	1	Rail, Conveyor Lower, Rear	05700-004-62-24
3	4	Hose Clamp, 2 9/16" to 3 1/2"	04730-003-15-40
4	1	Connector, 2" No Hub	04730-002-66-87
5	2	Tube, CVPC, 2"	05700-004-66-94
6	1	Hose, 2 1/2" ID, Blue, 10" Long	05700-004-72-48
7	1	Rail, Conveyor Lower	05700-004-62-05
8	1	Panel, Front	05700-004-61-90
9	2	Baffle, Wash Diverter	05700-004-72-00
10	1	Rail, Conveyor Upper, Front	05700-004-71-98
11	1	Handle, Top	05700-002-67-21
12	1	Panel, Vent	05700-004-61-68
13	1	Plumbing, Fill Assembly	05700-004-72-60

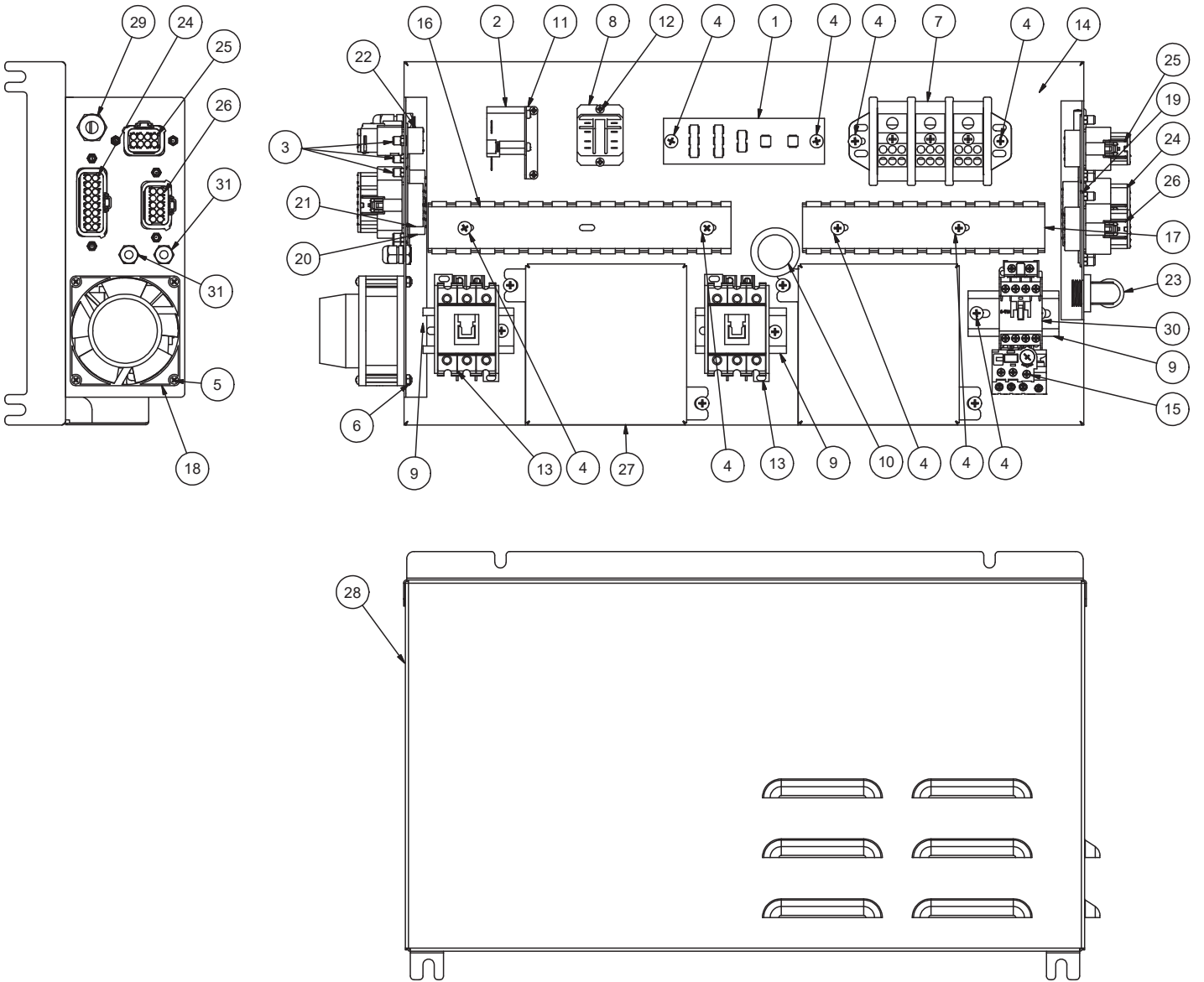

ITEM	QTY	DESCRIPTION	PART NUMBER
1	1	Terminal Board	05940-002-78-97
2	1	Thermostat	05930-004-33-12
3	30	Nut, Hex 10-32	05310-004-40-48
4	18	Screw, 10-32 x 3/4"	05305-011-62-17
5	4	Screw, 6-32 x 1 3/4"	05305-004-36-67
6	4	Locknut, 6-32 x 1/2" with Nylon Insert	05310-373-03-00
7	1	Terminal Block, 3-pole	05940-011-48-27
8	1	Relay, 2-Pole	05945-111-35-19
9	3	Din-rail, 3"	05700-011-84-65
10	1	Bushing, Snap	05975-003-10-46
11	1	Bracket, Thermostat	05700-004-36-37
12	4	Nut, 6-32 Plated	05340-118-04-00
	4	Screw, 6-32 x 1/2"	05305-004-23-63
13	1	Contactor, AC, 120 V	05945-002-65-98
14	1	Foam Insulation (Back of Box, Not Shown)	05700-004-61-45
15	1	Overload	See Motor Overloads page.
16	1	Panduit Bottom, 1 1/2" x 3" x 10"	05700-004-65-17
17	1	Panduit Bottom, 1 1/2" x 3" x 8"	05700-004-65-18
18	1	Fan	05999-004-19-46
19	1	Control Box	05700-004-73-68
20	2	Connector, 16-pin Mount	05940-004-73-27
21	2	Connector, 10-pin Mount	05940-004-73-28
22	2	Connector, 8-pin Mount	05940-004-73-29
23	1	Fitting, 1/2", 90-degree	05975-003-35-32
24	2	Connector, 16-pin Receptacle	05940-004-73-43
25	2	Connector, 8-pin Receptacle	05940-004-73-44
26	2	Connector, 10-pin Receptacle	05940-004-73-45
27	2	Cover, Heater	05700-004-73-71
28	1	Cover, Control Box	05700-004-74-07
29	1	Fitting	05975-011-49-03
30	1	Contactor, AC, 100 V	05945-004-25-78
31	2	Fitting, Nut and Cap	05975-205-43-00

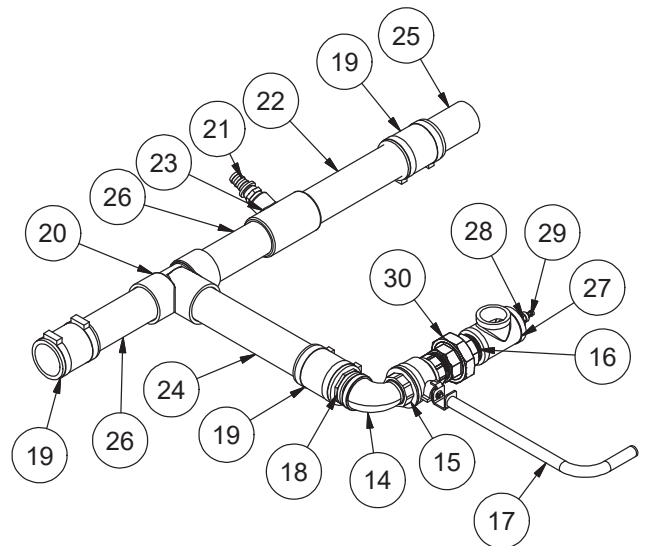
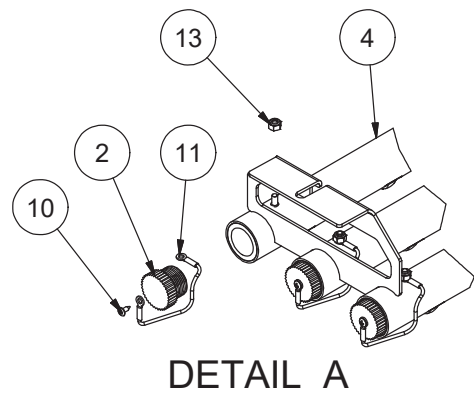
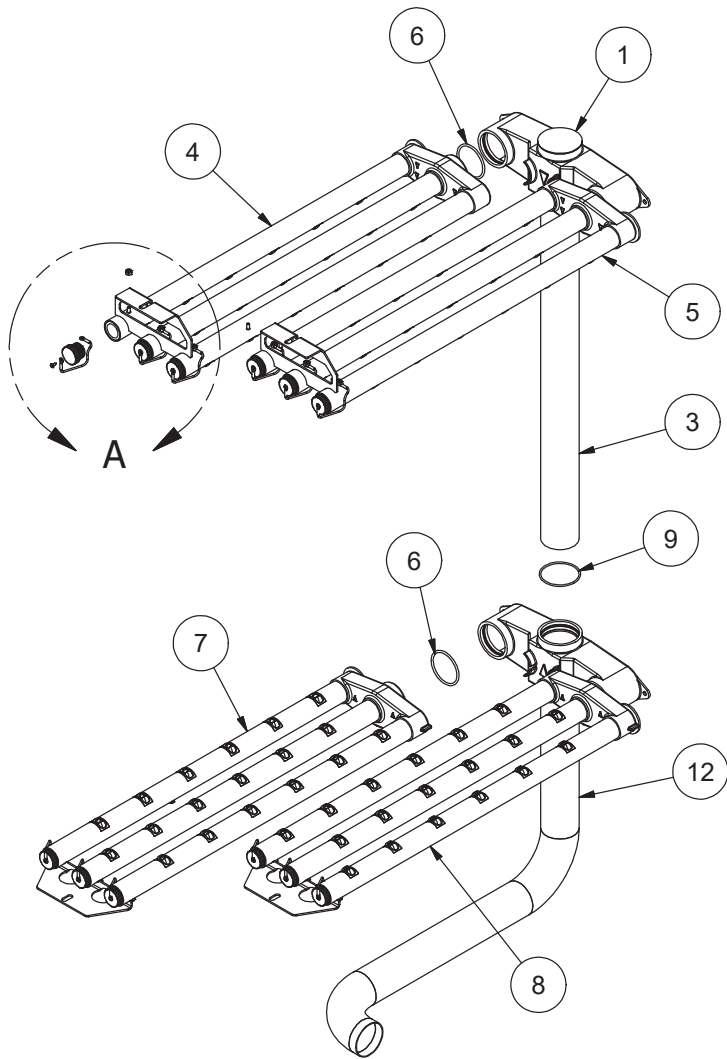

ITEM	QTY	DESCRIPTION	PART NUMBER
1	1	Wash Manifold, Upper	05700-003-73-66
2	12	Cap, Threaded	04730-603-12-00
3	1	Tube, Wash System Riser	05700-004-57-20
4	1	Wash Manifold, Upper Left	05700-004-57-22
5	1	Wash Manifold, Upper Right	05700-004-57-21
6	4	O-ring, 2 1/2"	05330-003-73-72
7	1	Wash Manifold, Lower Left	05700-004-57-24
8	1	Wash Manifold, Lower Right	05700-004-57-23
9	2	O-ring, 2 11/16"	05330-003-73-71
10	12	Screw, 6-40 x 3/8"	05305-002-63-49
11	12	Lanyard, 6"	05340-011-72-46
12	1	Wash Pump Manifold	05700-004-63-71
13	12	Locknut, 10-32 with Nylon Insert	05310-373-02-00
14	1	Elbow, 1 1/2" Brass, 90-degree	04730-206-32-00
15	1	Valve, Ball 1 1/2"	04820-111-71-46
16	2	Nipple, 1 1/2" Brass	04730-207-40-00
17	1	Drain Handle	05700-004-62-26
18	1	Fitting, 1 1/2"	04730-002-74-06
19	3	Connector, 2" No Hub	04730-002-66-87
20	1	Tee, 2"	04730-002-66-09
21	1	Fitting	04730-004-52-94
22	1	Tube, CVPC, 2" x 10 1/2"	05700-004-73-98
23	1	Reducing Tee	04730-004-63-80
24	1	Tube, CVPC, 2" x 11 1/2"	05700-004-64-38
25	1	Tube, CVPC, 2", Drain Right Side	05700-004-64-39
26	2	Tube, CVPC, 2", Drain Left Side	05700-004-66-94
27	1	Tee, 1 1/2"	04730-011-69-93
28	1	Reducer, 1 1/2" to 1/4"	04730-002-55-76
29	1	Fitting, 1/4"	04730-011-95-41
30	1	Union, 1 1/2"	04730-212-08-34

# PARTS

# POWER RINSE STEAM COIL & PLUMBING, L-R

**NOTICE** This steam coil assembly is used only in the FlightStar Steam Power Rinse Section, L-R.

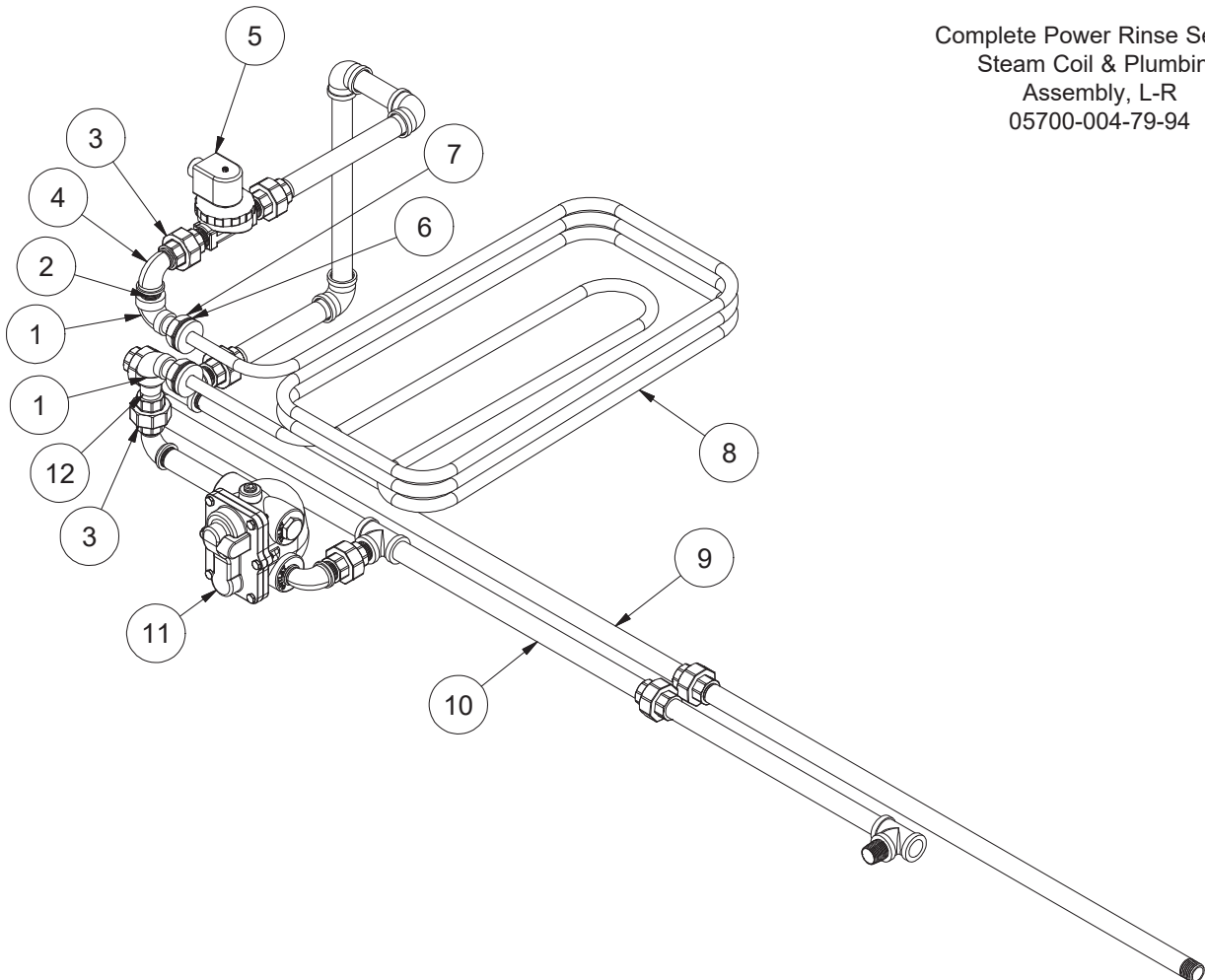

Complete Power Rinse Section  
Steam Coil & Plumbing  
Assembly, L-R  
05700-004-79-94

ITEM	QTY	DESCRIPTION	PART NUMBER
1	2	Elbow, 3/4" x 1/2" Black Iron	04730-003-75-92
2	8	Nipple, 3/4" Close Black Iron	04730-907-01-00
3	8	Union, 3/4" Black Iron	04730-912-01-00
4	3	Elbow, 90-degree, 3/4"	04730-011-87-37
5	1	Steam Valve Piping Assembly Solenoid Valve Only	05700-004-79-81 04820-011-87-39
6	4	Gasket, Steam Coil	05700-001-17-86
7	2	Nut, Steam Coil Adapter	05310-011-17-85
8	1	Steam Coil Assembly	05700-004-79-87
9	1	Steam Piping Assembly One	05700-004-79-89
10	1	Steam Piping Assembly Two	05700-004-79-90
11	1	Steam Trap Assembly	05700-004-79-93
12	1	Pipe, 3/4" x 2" Black Iron	04730-907-05-34

# PARTS

# POWER RINSE STEAM COIL & PLUMBING, R-L

**NOTICE** This steam coil assembly is used only in the FlightStar Steam Power Rinse Section, R-L.

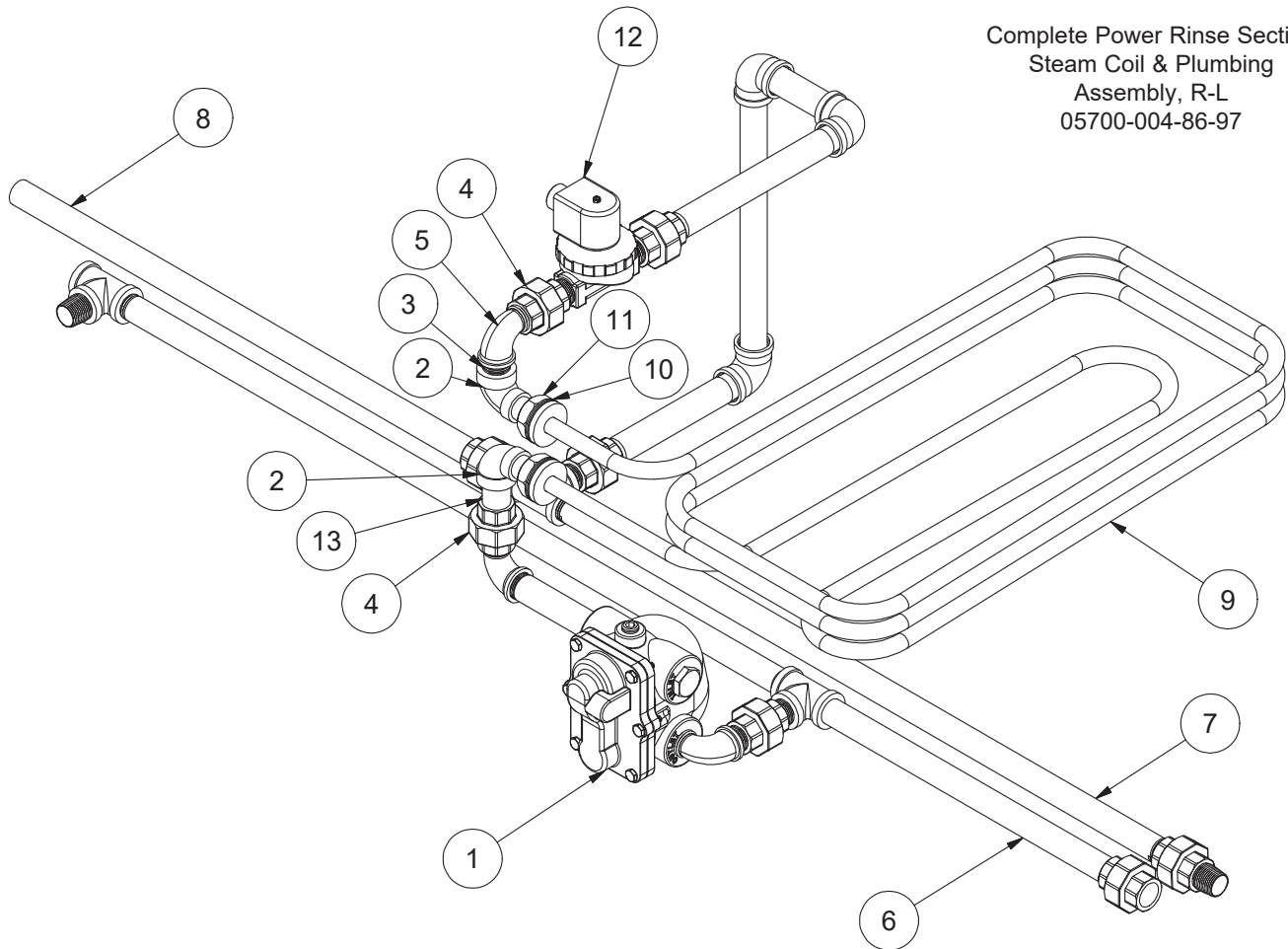

Complete Power Rinse Section  
Steam Coil & Plumbing  
Assembly, R-L  
05700-004-86-97

ITEM	QTY	DESCRIPTION	PART NUMBER
1	1	Steam Trap Assembly	05700-004-87-03
2	2	Elbow, 3/4" x 1/2" Black Iron	04730-003-75-92
3	1	Nipple, 3/4" Close Black Iron	04730-907-01-00
4	2	Union, 3/4" Black Iron	04730-912-01-00
5	1	Elbow, 90-degree, 3/4"	04730-011-87-37
6	1	Steam Piping Assembly One	05700-004-87-01
7	1	Steam Piping Assembly Two	05700-004-86-98
8	1	Nipple, 3/4" x 20" Black Iron	04730-004-87-02
9	1	Steam Coil Assembly	05700-004-79-87
10	4	Gasket, Steam Coil	05700-001-17-86
11	2	Nut, Steam Coil Adapter	05310-011-17-85
12	1	Steam Valve Piping Assembly Solenoid Valve Only	05700-004-79-81 04820-011-87-39
13	1	Nipple, 3/4" x 2" Black Iron	04730-004-85-28

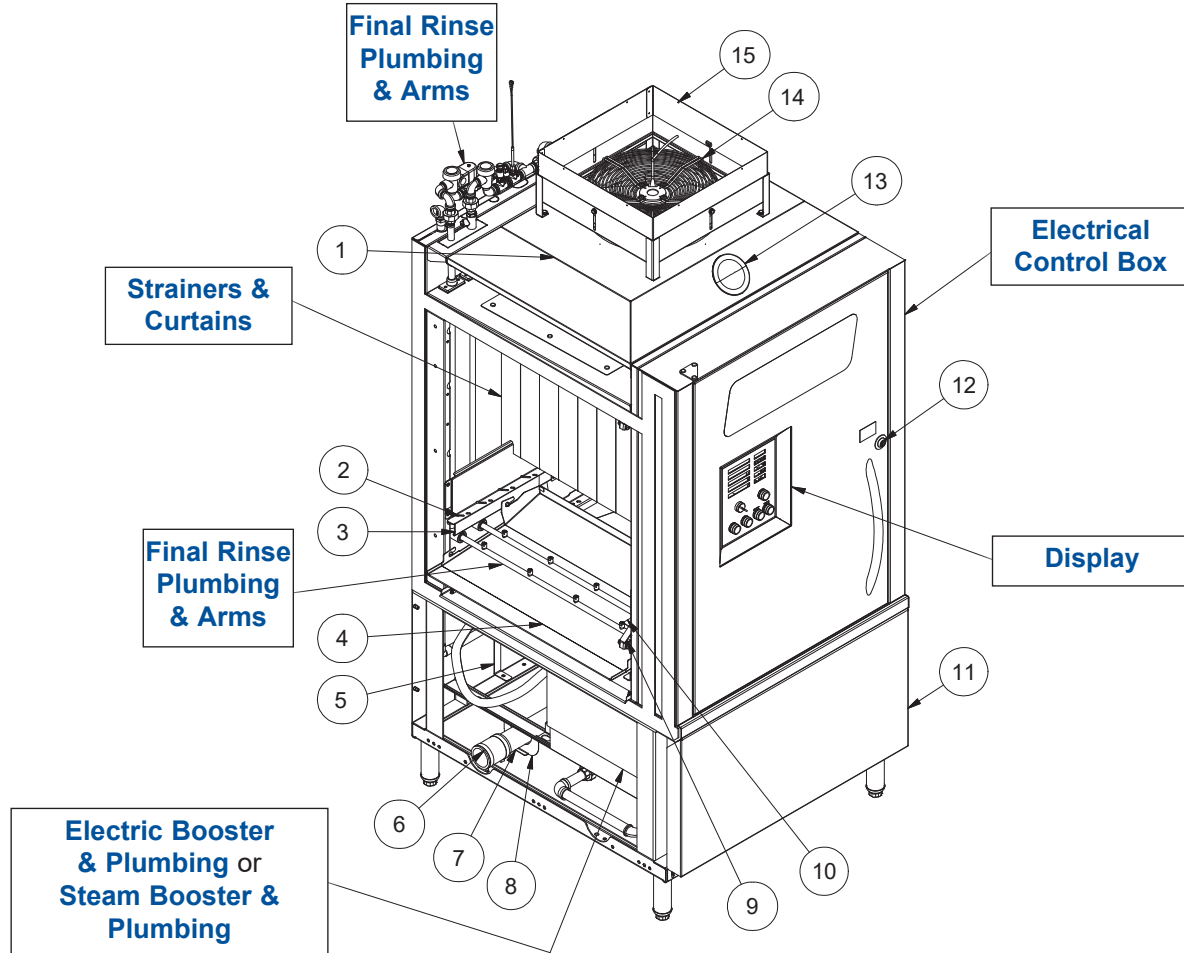

ITEM	QTY	DESCRIPTION	PART NUMBER
1	1	Cover, Electrical Section, FlightStar Cover, Electrical Section, FlightStar Steam	05700-004-73-54 05700-003-93-62
2	1	Rail, Conveyor Upper Rear	05700-004-71-98
3	2	Extension, Conveyor Rail	05700-004-82-19
4	1	Rinse Capture Pan	05700-004-73-56
5	1	Water Line Support	05700-004-77-57
6	2	Connector, 2" No-hub	04730-002-66-87
7	1	Plumbing, Drain, Electrical Section	05700-004-73-60
8	2	Bracket, Drain Pipe	05700-004-72-35
9	2	Rinse Arm Support	05700-004-69-85
10	1	Rail, Conveyor Upper Front	05700-004-71-99
11	1	Dress Panel, Front	05700-004-62-87
12	1	Latch, Door Compression	05340-002-80-97
13	1	Handle, Top Panel	05700-002-67-21
14	1	Vent Exhaust Fan	06105-002-86-46
15	1	Vent Adapter Assembly	05700-003-92-86

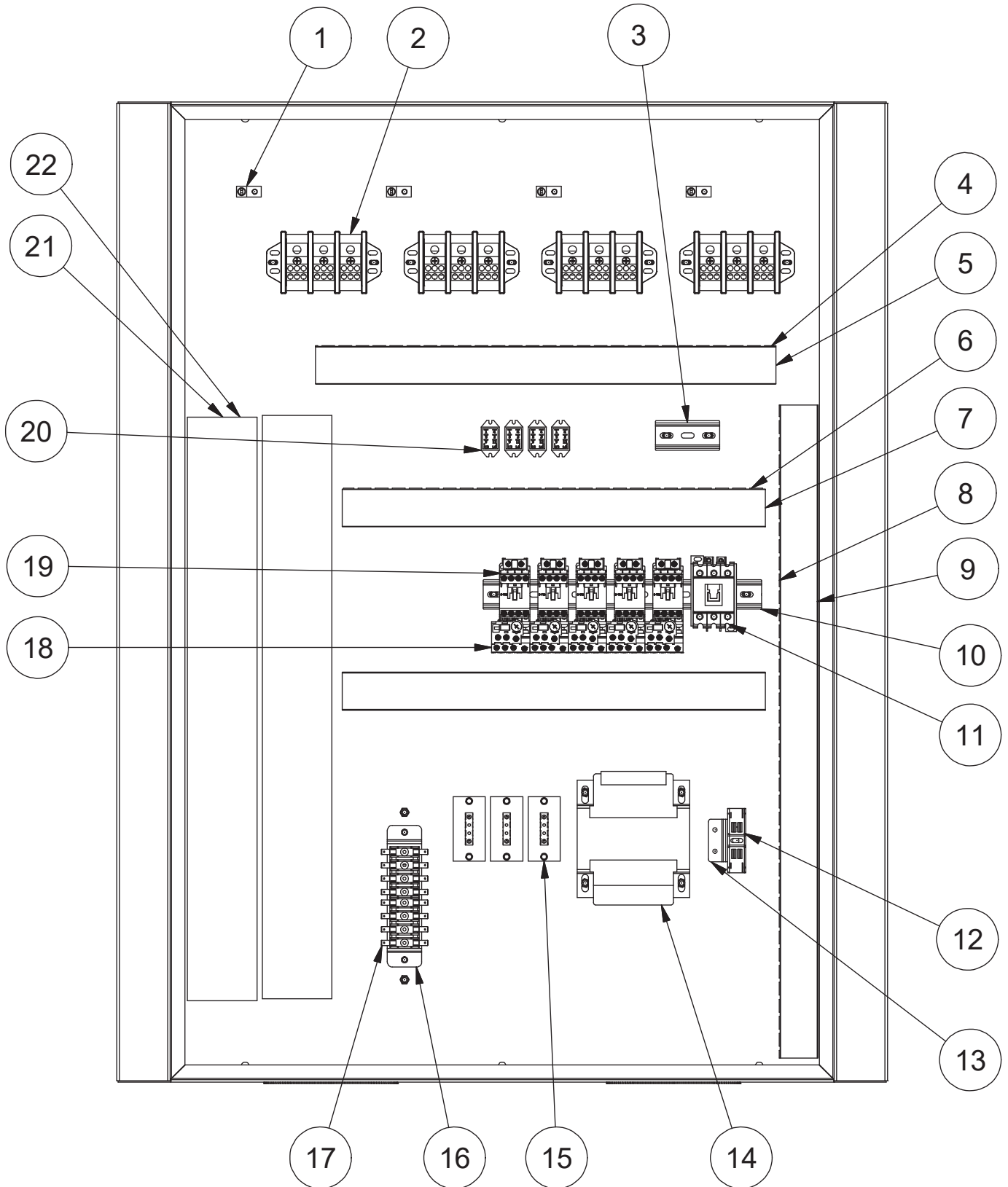

ITEM	QTY	DESCRIPTION	PART NUMBER
1	4	Ground Lug	05940-200-76-00
2	4	Terminal Block, 3-Pole	05940-011-48-27
3	1	Din Rail, 2"	05700-004-73-24
4	1	Bottom, Panduit 1 1/2" x 21 1/2"	05700-004-73-21
5	1	Cover, Panduit 1 1/2" x 21 1/2"	05700-004-73-22
6	2	Bottom, Panduit 1 1/2" x 19 3/4"	05700-004-73-18
7	2	Cover, Panduit 1 1/2" x 19 3/4"	05700-004-73-19
8	1	Bottom, Panduit 1 1/2" x 30 1/2"	05700-004-73-11
9	1	Cover, Panduit 1 1/2" x 30 1/2"	05700-004-73-17
10	1	Din Rail, 13"	05700-004-73-31
11	1	Contactor, 60 A	05945-002-65-98
12	1	Fuse Holder Fuse, 2 A, 460 V (208/230 V Units) (Not Shown) Fuse, 1 A, 460 V (460 V Units) (Not Shown)	05920-011-72-89 05920-002-67-30 05920-002-67-23
13	1	Bracket, Fuse Holder	05700-002-80-50
14	1	Transformer, 208/230/460 V	05950-004-63-51
15	3	Terminal Board	05940-021-94-85
16	1	Bracket, Fuse Strip	05700-004-32-36
17	2	Fuse Block, 6-Pole	05920-002-42-13
18	5	Overload	See Motor Overloads page.
19	5	Contactor	05945-004-25-78
20	4	Relay	05945-004-44-69
21	2	Bottom, Panduit 3" x 27 1/4"	05700-004-73-05
22	2	Cover, Panduit 3" x 27 1/4"	05700-004-73-10

**Pre-Wash Motor**

Volts	Phase	Freq	Motor Overload
208	3	60 Hz	05945-004-25-88
230	3	60 Hz	05945-004-25-88
460	3	60 Hz	05945-004-25-87

**Wash Motor**

Volts	Phase	Freq	Motor Overload
208	3	60 Hz	05945-004-25-88
230	3	60 Hz	05945-004-25-88
460	3	60 Hz	05945-004-25-87

**Power Rinse Motor**

Volts	Phase	Freq	Motor Overload
208	3	60 Hz	05945-004-25-88
230	3	60 Hz	05945-004-25-88
460	3	60 Hz	05945-004-25-87

**Drive Motor**

Volts	Phase	Freq	Motor Overload
208	3	60 Hz	05945-004-25-80
230	3	60 Hz	05945-004-25-80
460	3	60 Hz	05945-004-25-85

**Exhaust Fan Motor**

Volts	Phase	Freq	Motor Overload
208	3	60 Hz	05945-004-25-80
230	3	60 Hz	05945-004-25-80
460	3	60 Hz	05945-004-25-85

**Blower**

Volts	Phase	Freq	Motor Overload
208	3	60 Hz	05945-004-25-87
230	3	60 Hz	05945-004-25-87
460	3	60 Hz	05945-004-25-83

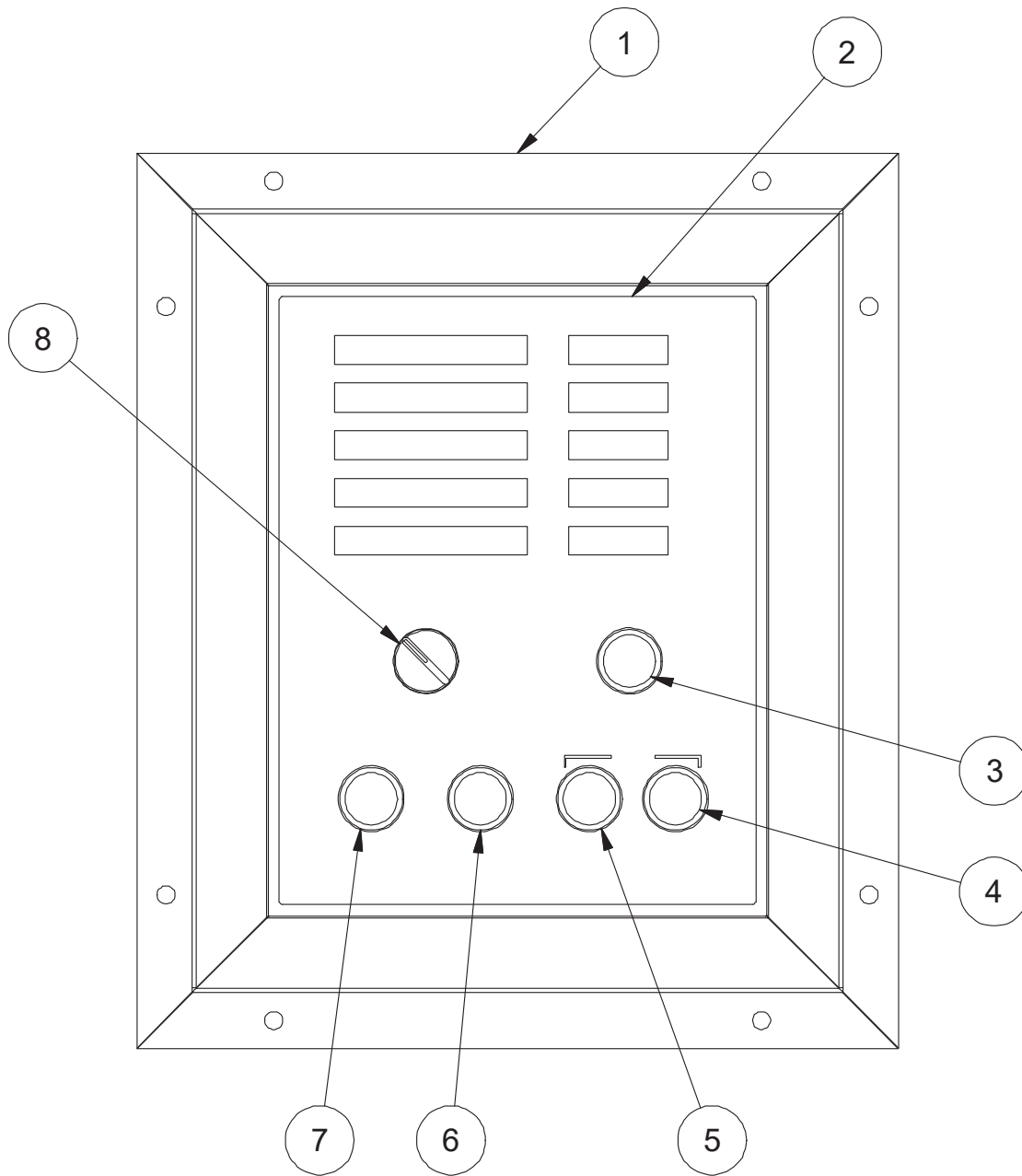

ITEM	QTY	DESCRIPTION	PART NUMBER
1	1	Panel, Display	05700-004-65-70
2	1	Decal, Display Panel	05999-004-62-39
3	1	Switch, Blue (Turbo)	05930-004-73-01
4	1	Switch, Red (Stop)	05930-004-72-99
5	1	Switch, Green (Start)	05930-004-72-98
6	1	Switch, Black (Delime)	05930-004-73-00
7	1	Switch, Green (Power)	05930-004-72-97
8	1	Switch, Black Rotary (Speed)	05930-004-73-03

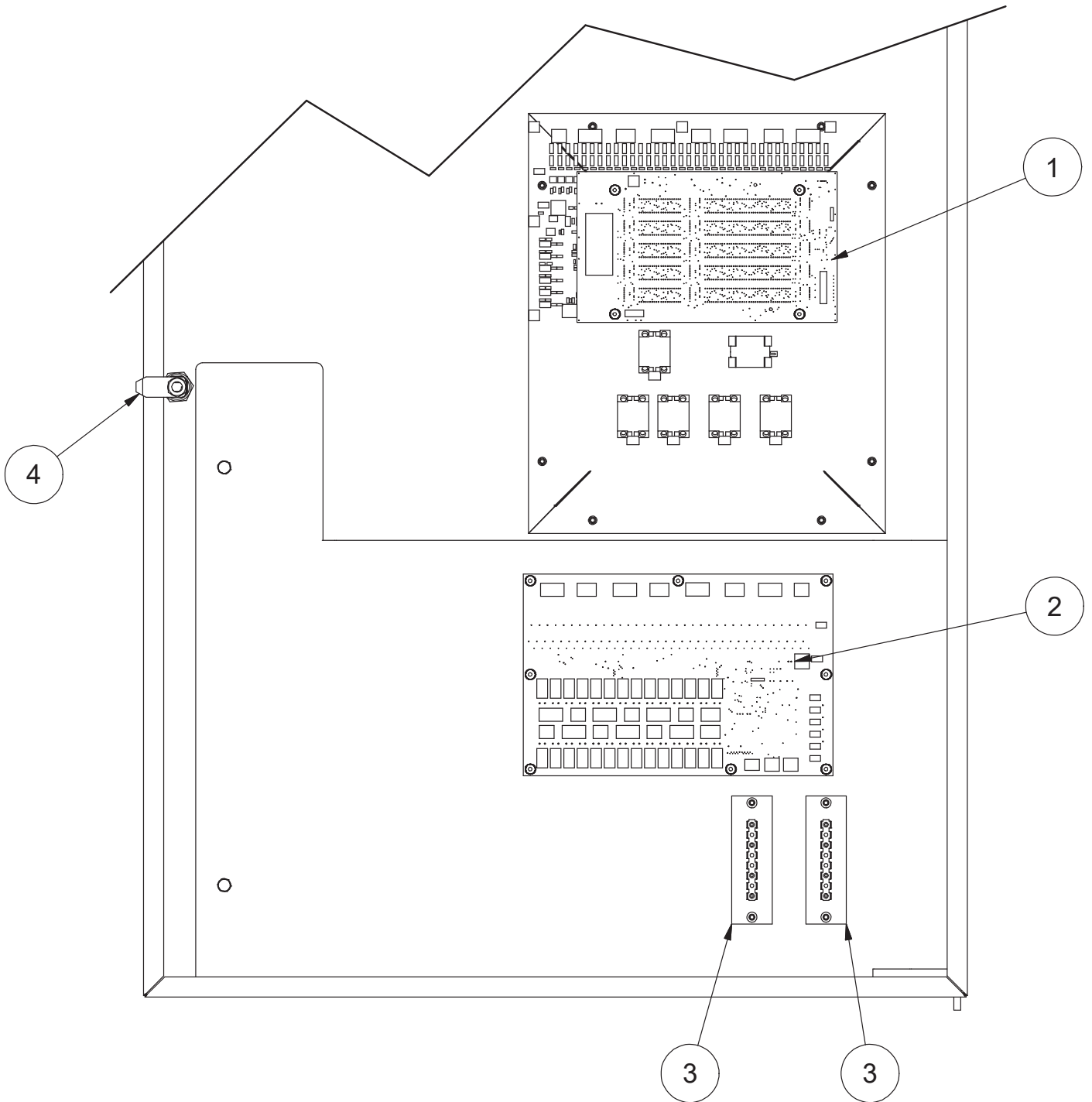

ITEM	QTY	DESCRIPTION	PART NUMBER
1	1	PCB, Display	05945-004-64-58
2	1	I/O Module	05945-004-64-57
3	2	Terminal Board	05940-004-21-34
4	1	Door Latch	05340-002-80-97
5	1	I/O Module Fuse (Not Shown)	05920-005-00-47

**NOTICE** L-R shown.

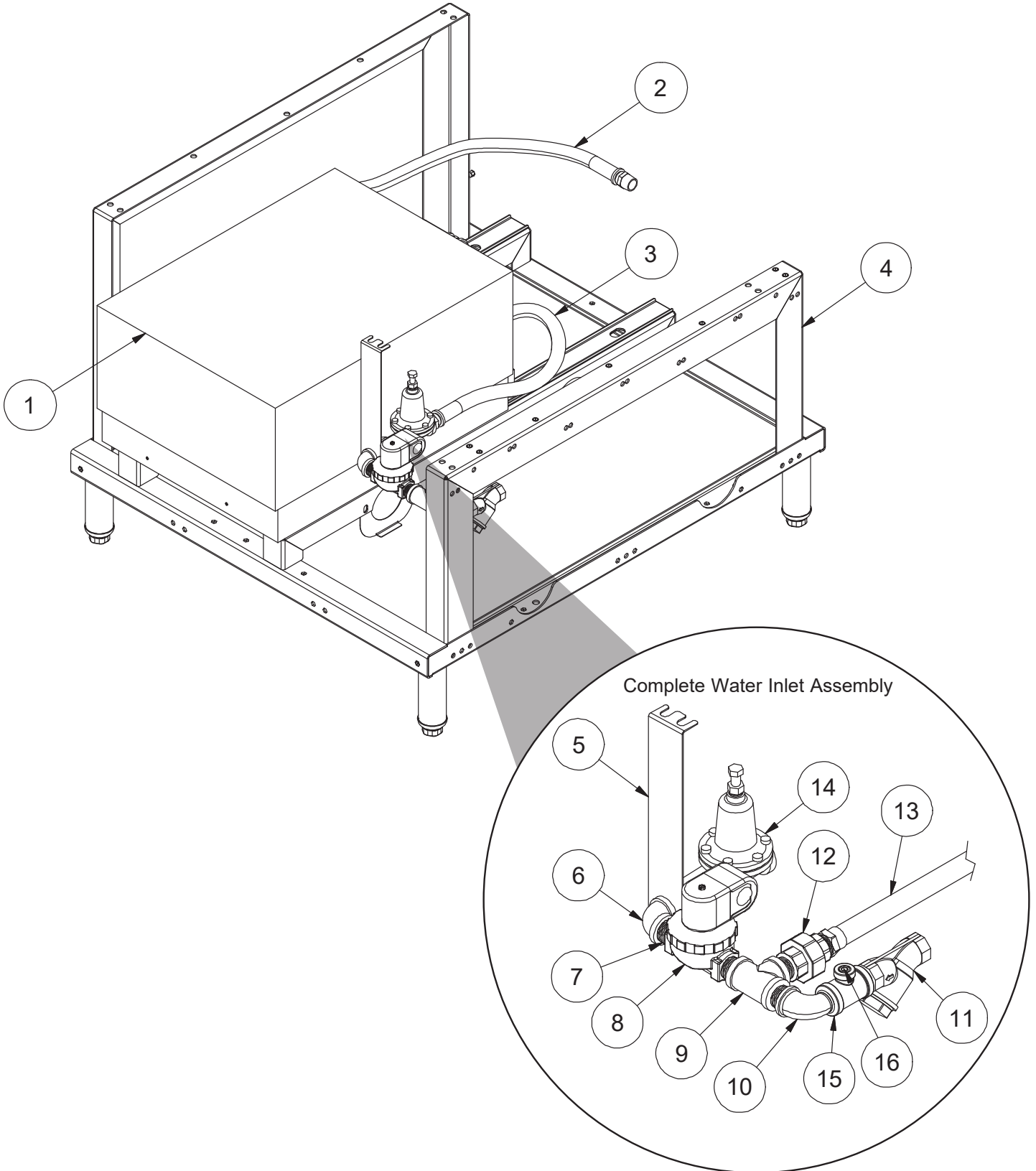

ITEM	QTY	DESCRIPTION	PART NUMBER
1	1	Heater, 27 kW, 208 V, 3 PH Booster Heater, 27 kW, 230 V, 3 PH Booster Heater, 27 kW, 460 V, 3 PH Booster	04540-500-05-00 04540-500-02-00 04540-500-12-00
2	1	Booster Hose, Top, L-R Booster Hose, Top, R-L	05700-004-72-47 05700-004-76-41
3	1	Booster Hose, Bottom, L-R Booster Hose, Bottom, R-L	05700-004-72-45 05700-004-76-43
4	1	Frame, Electrical Section	05700-004-62-76
5	1	Bracket, Booster Piping	05700-004-85-39
6	1	Elbow, 3/4" 90-degree Brass	04730-206-13-00
7	5	Nipple, 3/4" x 1 3/8" Brass	04730-207-34-00
8	1	Solenoid Valve, 3/4"	04810-100-53-00
9	1	Tee, 3/4" x 3/4" x 3/4" Brass	04730-211-01-34
10	1	Elbow, 3/4" 90-degree Brass	04730-206-04-34
11	1	Y-strainer, 3/4" Brass	04730-717-02-06
12	1	Union, 3/4"	04730-212-05-00
13	1	Water Inlet Riser Assembly	05700-004-63-09
14	1	Pressure Regulating Valve, 3/4"	06685-011-58-22
15	1	Tee, 3/4" x 3/4" x 1/4" Brass	04730-211-04-00
16	1	Plug, 1/4" Hex Socket Flush Brass	04730-004-23-47

Complete Water Inlet Assembly  
L-R 05700-004-63-10  
R-L 05700-004-76-39

*Contains items 5-16 above.*

**NOTICE** L-R shown.

See Steam Booster manual for booster parts.

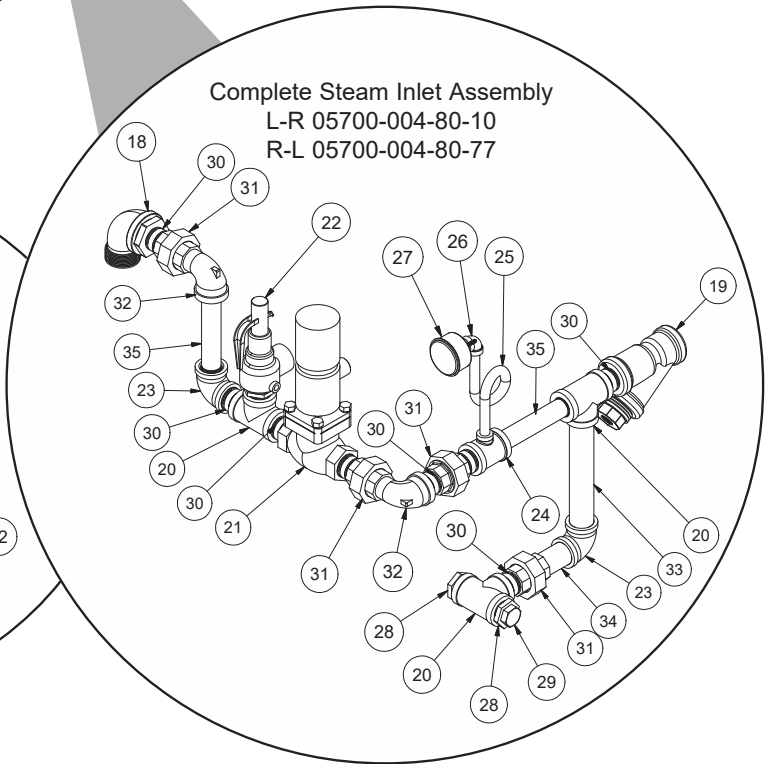
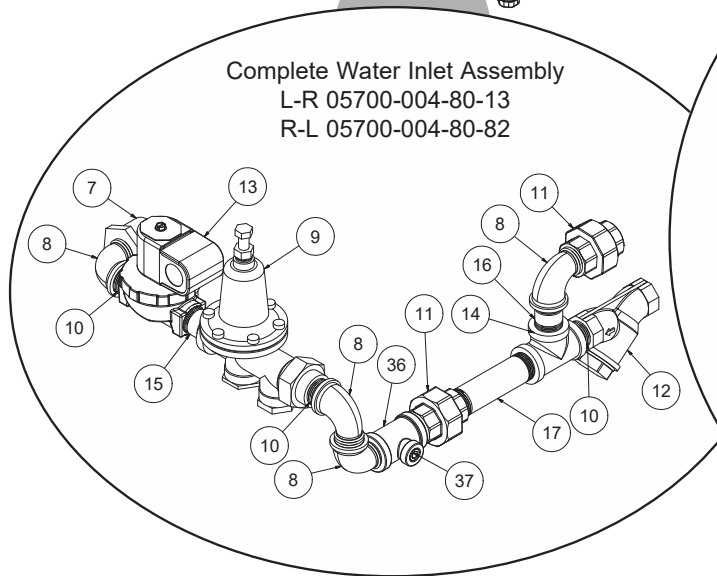
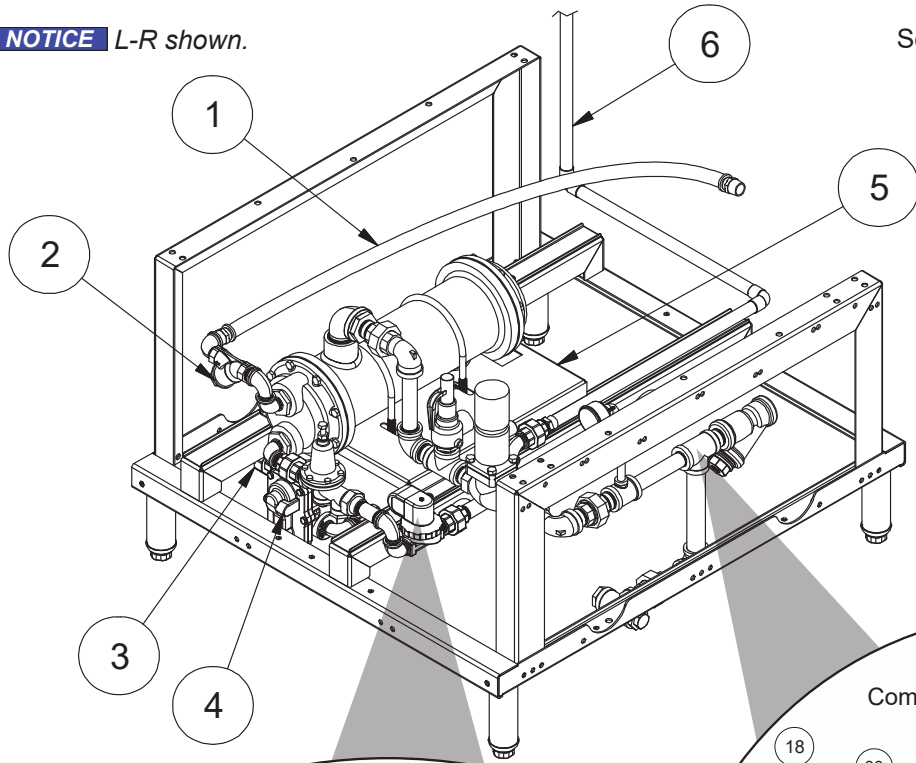

ITEM	QTY	DESCRIPTION	PART NUMBER
1	1	Hose Assembly	05700-004-86-27
2	1	Outlet Assembly, L-R Outlet Assembly, R-L	05700-004-80-11 05700-004-80-81
3	1	Condensate Manifold Assembly, L-R Condensate Manifold Assembly, R-L	05700-004-80-00 05700-004-86-31
4	1	Steam Trap, L-R Steam Trap, R-L	05700-004-79-98 05700-004-94-76
5	1	Bracket, Steam Booster, L-R Bracket, Steam Booster, R-L	05700-004-80-84 05700-004-80-85

ITEM	QTY	DESCRIPTION	PART NUMBER
6	1	Water Inlet Riser Assembly, L-R Water Inlet Riser Assembly, R-L	05700-004-86-22 05700-004-86-25
7	1	Bushing, 1 1/4" x 3/4"	04730-011-88-80
8	4	Elbow, 3/4" 90-degree Brass	04730-206-04-34
9	1	Pressure Regulating Valve, 3/4"	06685-011-58-22
10	4	Nipple, 3/4" x 1 3/8" Brass	04730-207-34-00
11	3	Union, 3/4"	04730-212-05-00
12	1	Y-strainer, 3/4" Brass	04730-717-02-06
13	1	Solenoid Valve, 3/4"	04810-100-53-00
14	1	Tee, 3/4" x 3/4" x 3/4" Brass	04730-211-01-34
15	1	Nipple, 3/4" x 3" Brass	04730-011-38-29
16	1	Nipple, 3/4" x 2" Brass	04730-207-46-00
17	1	Nipple, 3/4" x 4 1/2" Brass	04730-004-04-53
18	1	Bushing, 1 1/2" x 1" Black Iron	04730-002-36-79
19	1	Y-strainer, 1" Black Iron	04730-217-02-32
20	3	Tee, 1" x 1" x 1" Black Iron	04730-911-01-34
21	1	Valve, 1" Bronze Steam	04810-002-92-23
22	1	Valve, Safety Relief	04820-100-01-35
23	2	Elbow, 90-degree, 1"	04730-906-03-34
24	1	Tee, 1" x 1" x 1/4" Black Iron	04730-911-01-00
25	1	Nipple, Pigtail, 1/4" Black Iron	04730-907-14-34
26	1	Elbow, 90-degree, 1/4" Black Iron	04730-002-87-10
27	1	Gauge, 0–100 PSI	06680-011-86-42
28	2	Reducer, 1" to 3/4"	04730-011-95-66
29	1	Plug, 3/4" Black Iron	04730-004-02-72
30	8	Nipple, 1" Close Black Iron	04730-907-08-34
31	4	Union, 1" Black Iron	04730-912-01-34
32	2	Elbow, 1" Street Black Iron	04730-002-86-58
33	1	Nipple, 1" x 8" Black Iron	04730-004-84-30
34	1	Nipple, 1" x 3" Black Iron	04730-004-80-03
35	2	Nipple, 3/4" x 6" Black Iron	04730-907-01-34
36	1	Tee, 3/4" x 3/4" x 1/4" Brass	04730-211-04-00
37	1	Plug, 1/4" Hex Socket Flush Brass	04730-004-23-47

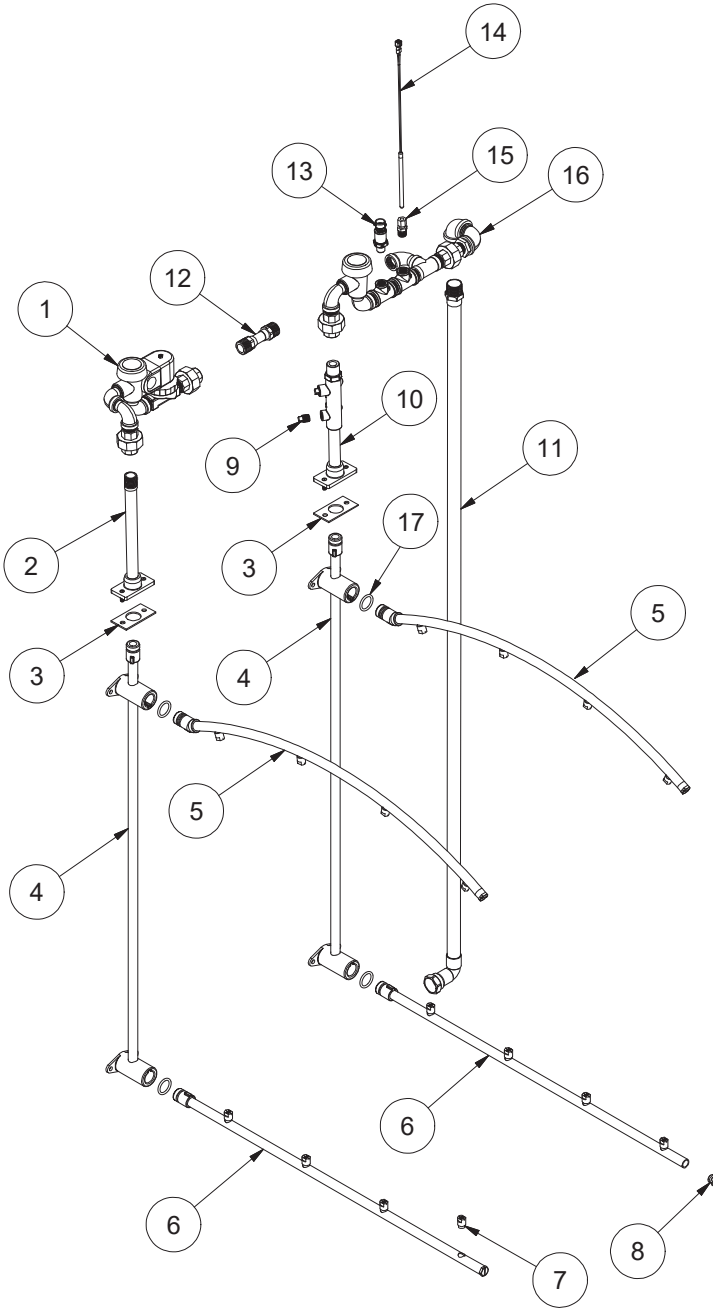

Complete Final Rinse Plumbing Assembly  
05700-004-63-11

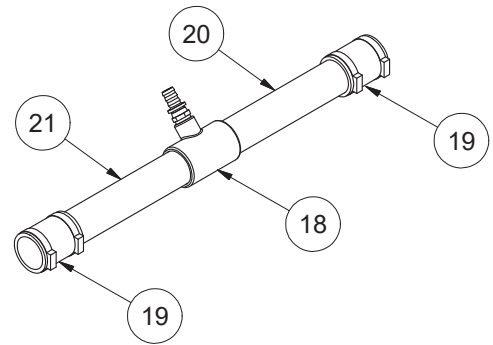
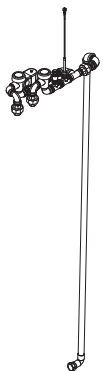

Complete Final Rinse Arm Assembly  
05700-004-63-05  
*Does not include Item #8.*

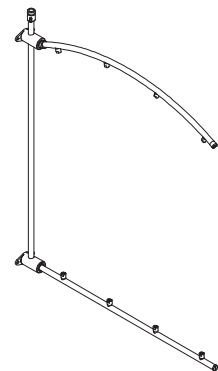

ITEM	QTY	DESCRIPTION	PART NUMBER
1	1	Rinse Inlet Valve Assembly Two	05700-004-63-15
2	1	Rinse Nozzle Extension	05700-004-63-08
3	2	Gasket, Rinse Manifold	05330-003-75-91
4	2	Rinse Manifold Assembly	05700-004-62-92
5	2	Rinse Arm, Upper Arched (Includes Item #7)	05700-003-94-59
6	2	Rinse Arm, Lower (Includes Item #7)	05700-003-94-60
7	16	Nozzle, Rinse Arm	04730-003-76-06
8	4	End-cap, Rinse Arm	05700-011-35-92
9	4	Plug, 1/4" Brass	04730-211-01-34
10	1	Rinse Injector (Includes Item #9)	05700-004-73-62
11	1	Rinse Inlet Riser Assembly	05700-004-63-12
12	1	Rinse Inlet Section	05700-004-63-13
13	1	Pressure Transducer	05945-004-17-01
14	1	Thermistor Probe	06685-004-17-26
15	1	Compression Fitting, 1/4" x 1/4"	04730-011-48-56
16	1	Rinse Inlet Valve Assembly One	05700-004-63-14
17	4	O-ring, Silicone, 11/16" x 7/8"	05330-003-77-82
18	1	Reducing Tee	04730-004-63-80
19	2	Connector, 2" No Hub	04730-002-66-87
20	1	Fitting	04730-004-52-94
21	2	Tube, CVPC, 2" x 12 1/2"	05700-004-73-59
22	2	Fill Hose, 3/4", 33" Long, L-R & R-L (Not Shown)	05700-004-72-40
23	1	Fill Hose, 3/4", 22" Long, L-R (Not Shown) Fill Hose, 3/4", 14" Long, R-L (Not Shown)	05700-004-72-62 05700-004-92-53

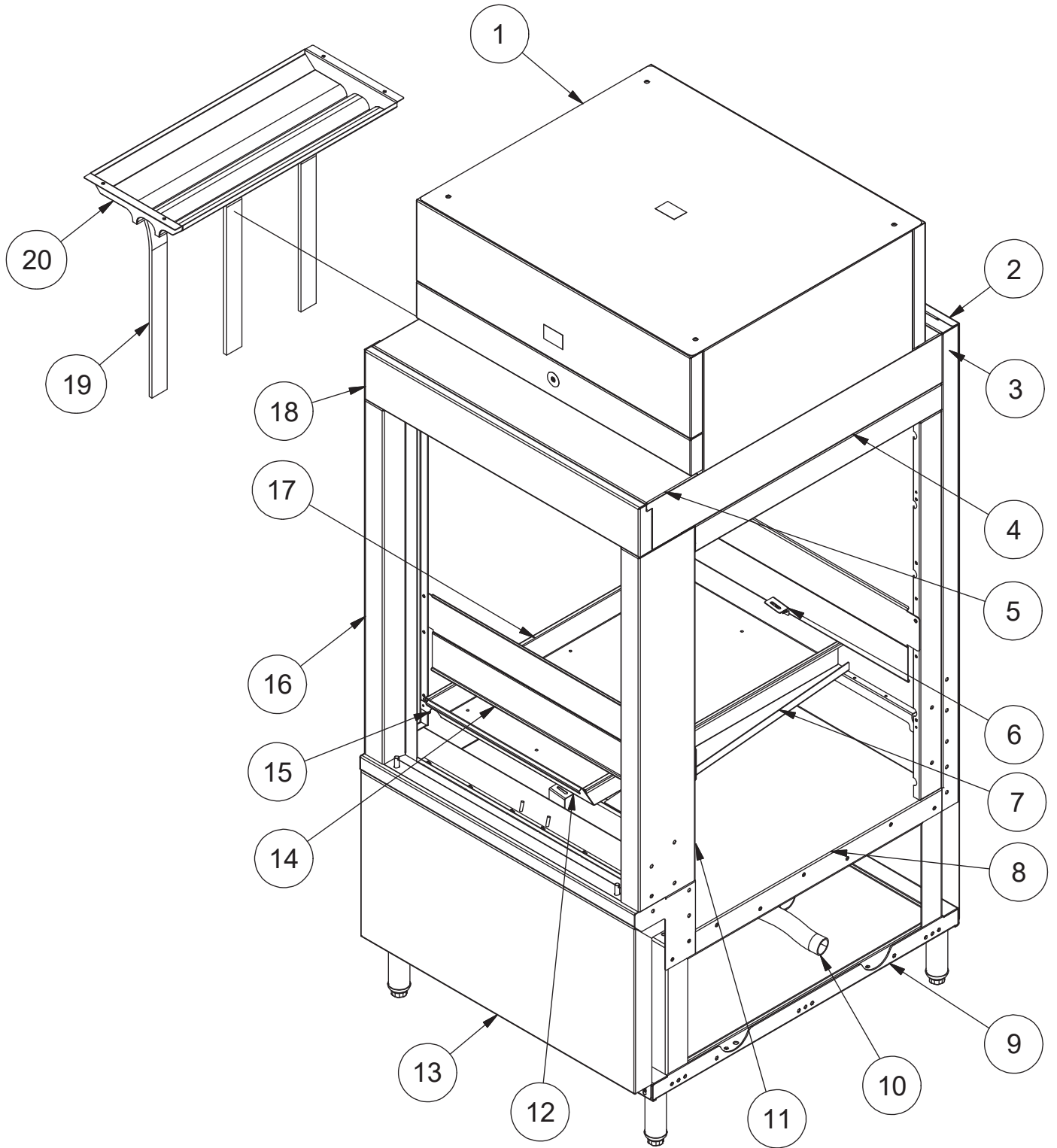

ITEM	QTY	DESCRIPTION	PART NUMBER
1	1	Blower Assembly	See next page.
2	1	Dress Panel, Rear	05700-004-72-74
3	1	Rear Panel, Blower	05700-004-78-81
4	1	End Plate Panel, Blower Right End Plate Panel, Blower Left (Not Shown)	05700-004-74-32 05700-004-74-14
5	1	Front Top Cover, Blower	05700-004-74-16
6	1	Bracket, Upper Rear Rail Support Bracket, Upper Front Rail Support (Not Shown)	05700-004-75-96 05700-004-75-95
7	1	Tray Support, Right Tray Support, Left (Not Shown)	05700-004-74-99 05700-004-74-98
8	1	Bottom Plate, Blower	05700-004-74-25
9	1	Frame Assembly	05700-004-77-63
10	1	Complete Drain Assembly, Blower	05700-004-75-02
11	1	Support, Corner Post, RH, L-R Support, Corner Post, RH, R-L	05700-004-75-27 05700-004-75-44
12	1	Bracket, Lower Front Rail Support Bracket, Lower Rear Rail Support (Not Shown)	05700-004-75-97 05700-004-75-98
13	1	Dress Panel, Front	05700-004-62-87
14	2	Guard, Conveyor Rear	05700-004-62-69
15	2	Tray Rail, Blower	05700-004-74-20
16	1	Support, Corner Post, LH, L-R Support, Corner Post, LH, R-L	05700-004-72-07 05700-004-76-68
17	1	Tray, Blower	05700-004-74-87
18	1	Door Header, Blower, L-R Door Header, Blower, R-L	05700-004-75-74 05700-004-76-67
19	3	Dish Stabilizer	05330-003-04-43
20	1	Blower Air Knives Box	05700-003-92-04

**STEAM BLOWER, FLIGHTSTAR STEAM**

Complete Assembly  
05700-004-78-93

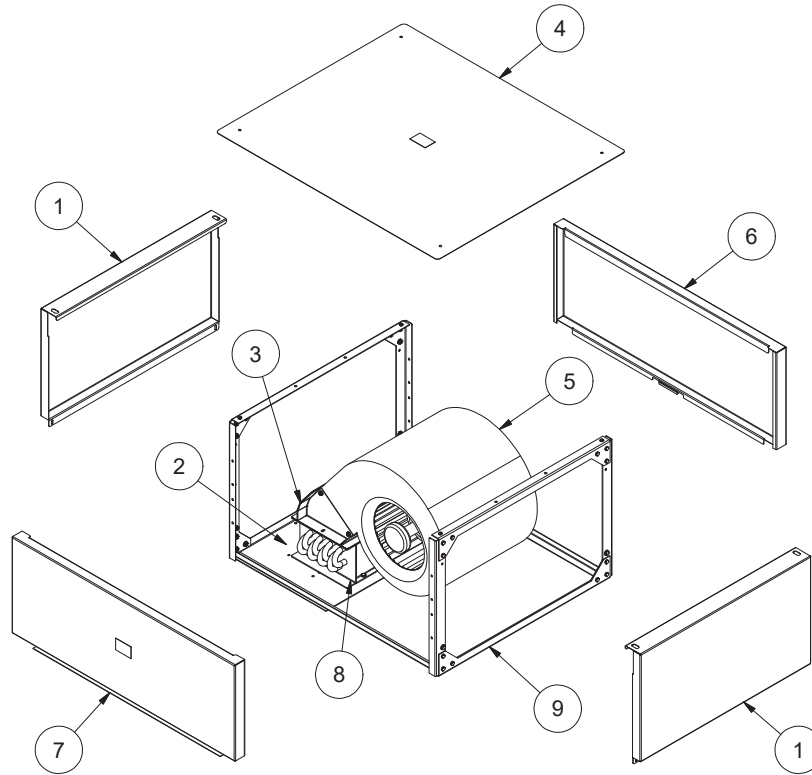

**ELECTRIC BLOWER, FLIGHTSTAR**

Complete Assembly  
05700-004-73-97

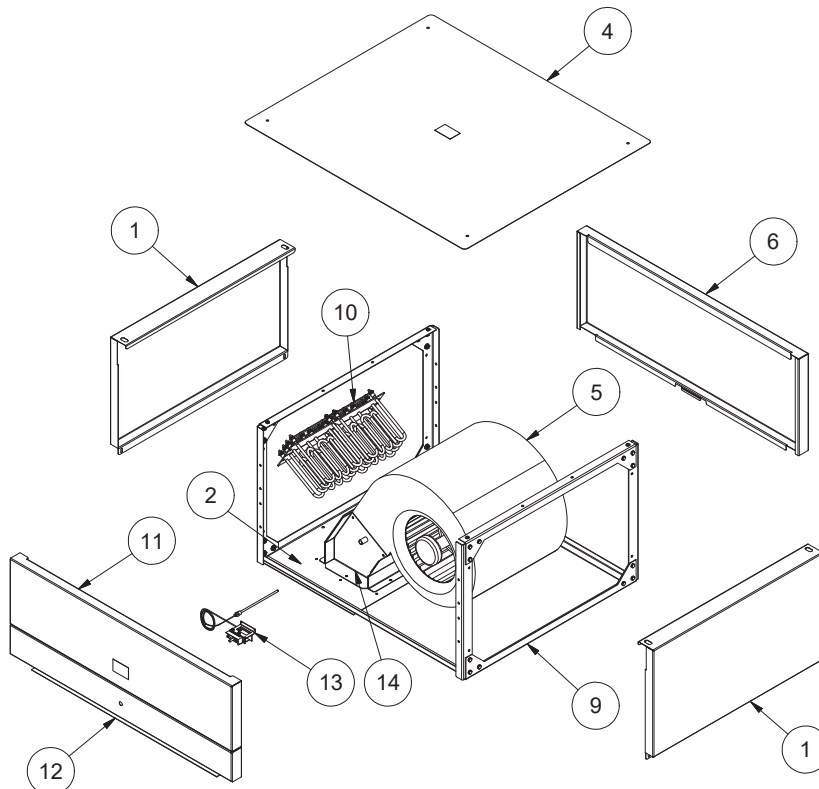

ITEM	QTY	DESCRIPTION	PART NUMBER
1	2	Panel, Blower Side	05700-002-71-99
2	1	Plate, Blower Support	05700-002-84-67
3	1	Blower Dryer Heater Box, FlightStar Steam	05700-002-76-85
4	1	Panel, Blower Top	05700-002-72-00
5	1	Blower, 208-230/600 V, 60 Hz, Dual Cage Blower, 460 V, 60 Hz, Dual Cage	06105-002-72-15 06105-002-88-36
6	1	Panel, Blower Back	05700-004-74-09
7	1	Panel, Blower Front	05700-004-78-92
8	1	Heat Exchanger, FlightStar Steam	04420-002-76-68
9	1	Frame Assembly	05700-002-84-68
10	2	Heater, 4.5 kW, 208 V, FlightStar Heater, 4.5 kW, 240 V, FlightStar Heater, 4.5 kW, 460 V, FlightStar Heater, 4.5 kW, 600 V, FlightStar	04540-002-74-29 04540-002-87-79 04540-002-91-60 04540-002-90-30
11	1	Panel, Blower Front, FlightStar	05700-003-91-89
12	1	Panel, Blower Front Lower, FlightStar	05700-004-75-81
13	1	High Limit Thermostat, FlightStar	05930-003-92-41
14	1	Blower Dryer Heater Box, FlightStar	05700-002-72-14

## ITEMS NOT SHOWN, FLIGHTSTAR STEAM

15	2	Nipple, 3/4" x 2" Brass Heat Exchanger	04730-002-90-27
16	2	Elbow, 3/4" 90-degree, Brass Heat Exchanger	04730-206-04-34
17	1	Hose Assembly, Outlet	05700-002-87-95
18	1	Hose Assembly, Inlet	05700-002-87-96

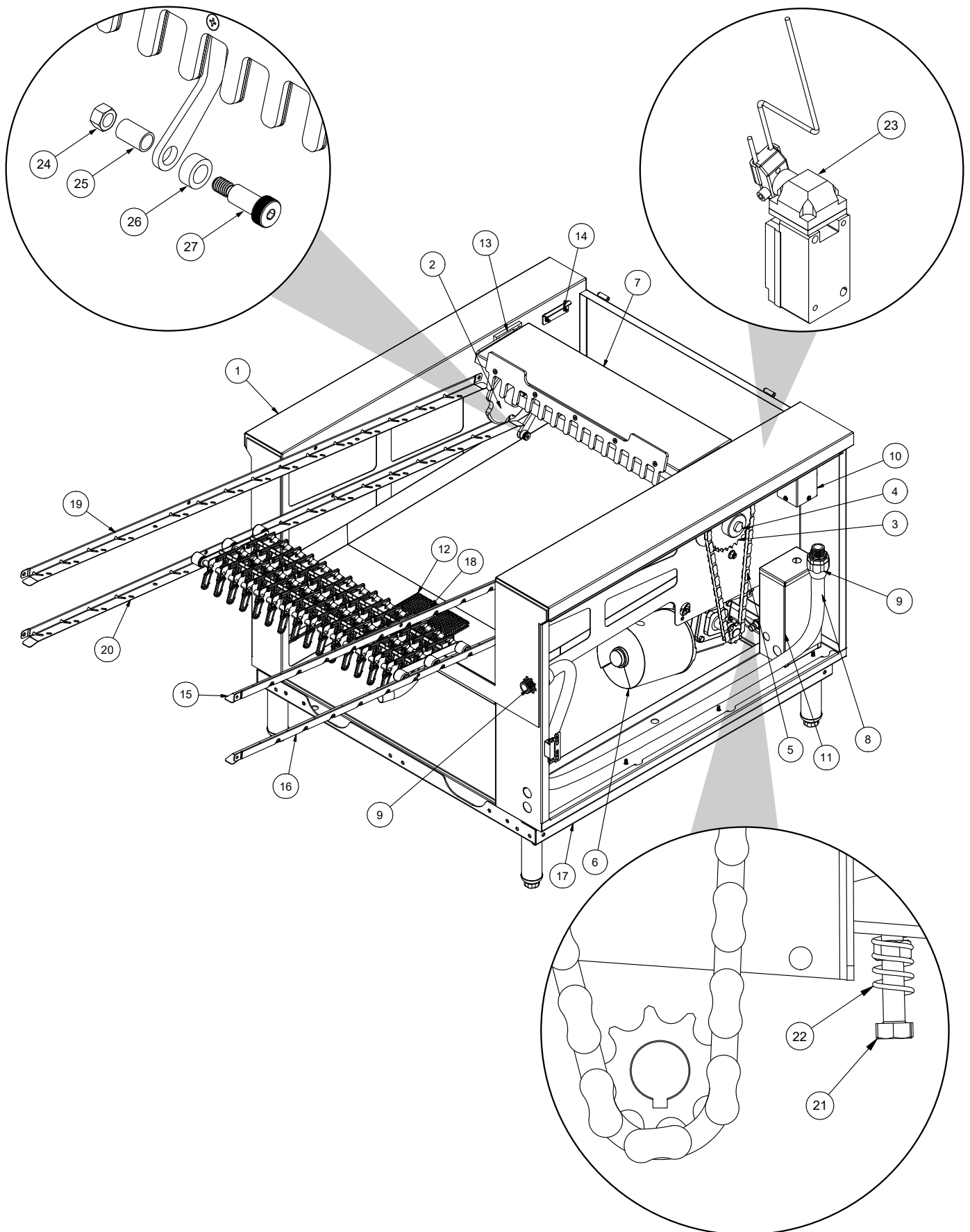

ITEM	QTY	DESCRIPTION	PART NUMBER
1	1	Tank, L-R	05700-004-74-46
2	2	Conveyor Drive Wheel	05700-002-67-03
3	1	Belt Sprocket	06105-002-75-22
4	1	Drive Shaft	05700-004-63-85
5	1	Drive Assembly Chain	05700-002-88-43
6	1	<b>L-R</b> Drive Motor Assembly, 208/230 V Drive Motor Assembly, 460 V Gear Drive Only, 208/230/460 V <b>R-L</b> Drive Motor Assembly, 208/230 V Drive Motor Assembly, 460 V Gear Drive Only, 208/230/460 V <hr/> <b>L-R/R-L</b> Drive Motor Only, 208/230 V Drive Motor Only, 460 V	<b>L-R</b> 05700-002-66-38 05700-002-68-55 06105-002-68-52 <b>R-L</b> 05700-004-76-90 05700-004-80-76 06105-004-76-74 <hr/> <b>L-R/R-L</b> 06105-002-87-69 06105-002-87-70
7	1	Conveyor Shut-off Assembly	05700-004-74-66
8	1	Conduit, 1" x 62 3/4"	05700-004-79-00
9	2	Straight Plastic Fitting, 1"	05975-011-70-75
10	1	Switch Box	05700-004-74-88
11	1	Junction Box	05700-004-74-92
12	1	Strainer	05700-004-73-25
13	2	Guide Block	05700-004-74-77
14	2	Shelf Stop Bracket	05700-004-74-84
15	1	Upper Rail 1	05700-004-74-96
16	1	Lower Rail 1	05700-004-75-25
17	1	Base Assembly	05700-004-63-73
18	1	Drain	05700-003-02-24
19	1	Upper Rail 2	05700-005-11-06
20	1	Lower Rail 2	05700-005-14-67
21	2	Bolt, Spring Holding, 3/8"	05340-002-87-02
22	2	Spring	05340-002-87-62
23	1	Limit Switch, Conveyor Shut-off Kit, Limit Switch Install, L-R Kit, Limit Switch Install, R-L	05700-005-00-31 06401-005-00-16 06401-005-00-20
24	2	Nut, Hex, 3/8-16	05310-276-01-00
25	2	Bushing, Bronze	05700-004-74-75
26	2	Bushing, Nylon	05700-004-74-72
27	2	Bolt, Socket Head, Shoulder	05700-004-74-73

**STRAIGHT EXPANSION SECTION**

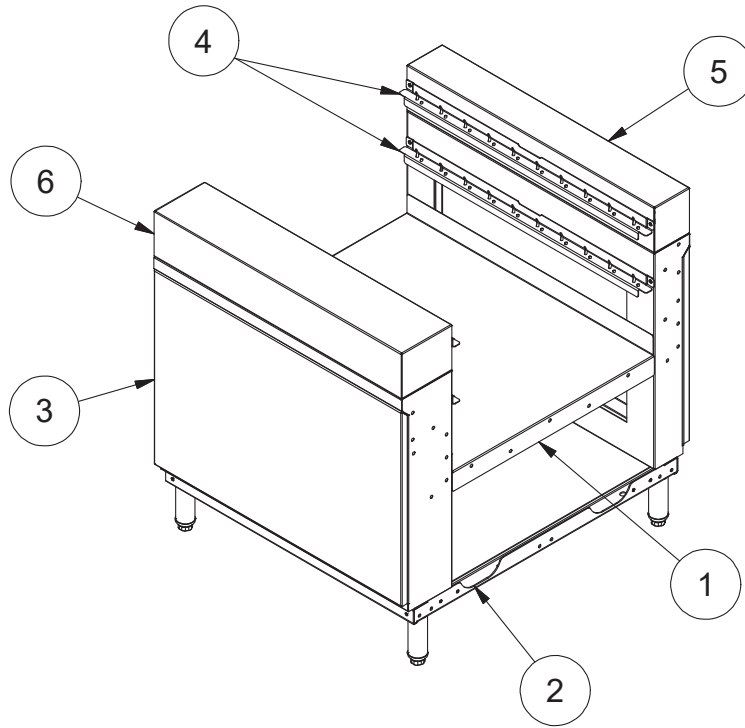

**ANGLED EXPANSION SECTION**

Risers on Unload Expansion are angled if it's the last section before the Unload Section. Parts are identical to the above except for the risers.

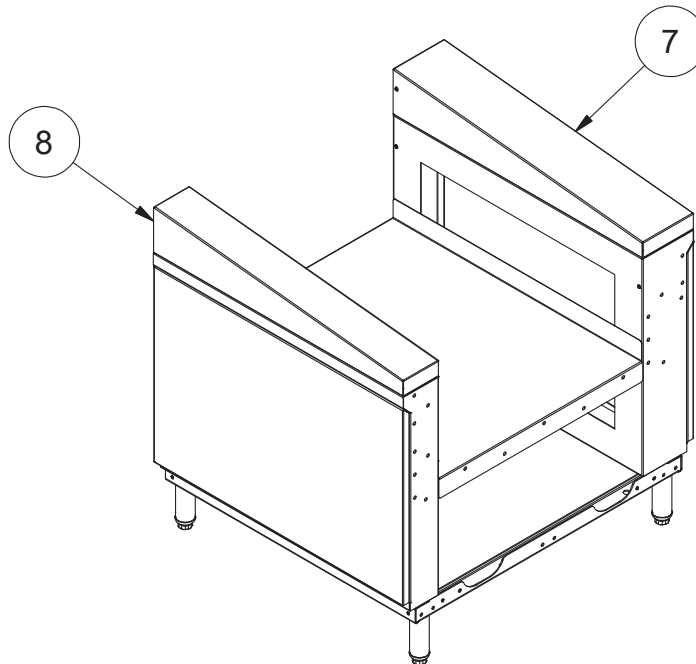

ITEM	QTY	DESCRIPTION	PART NUMBER
1	1	Tank	05700-004-80-28
2	1	Base	05700-004-80-30
3	2	Side Dress Panel	05700-004-80-21
4	4	Conveyor Rail, Lower Rear	05700-004-62-24
5	1	Riser, Rear Straight	05700-004-81-24
6	1	Riser, Front Straight	05700-004-81-22
7	1	Riser, Rear Angled, L-R Riser, Rear Angled, R-L	05700-004-81-35 05700-004-81-39
8	1	Riser, Front Angled, L-R Riser, Front Angled, R-L	05700-004-81-25 05700-004-81-37

**STRAIGHT EXPANSION SECTION**

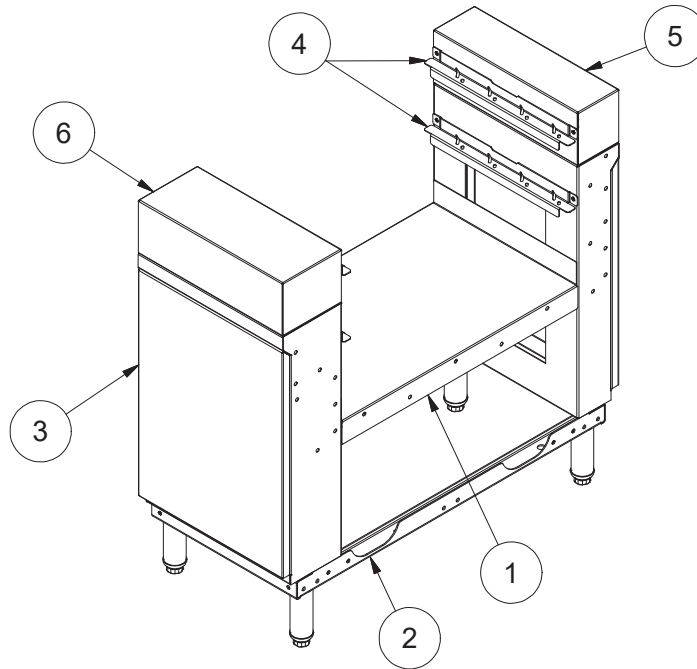

**ANGLED EXPANSION SECTION**

Risers on Unload Expansion are angled if it's the last section before the Unload Section. Parts are identical to the above except for the risers.

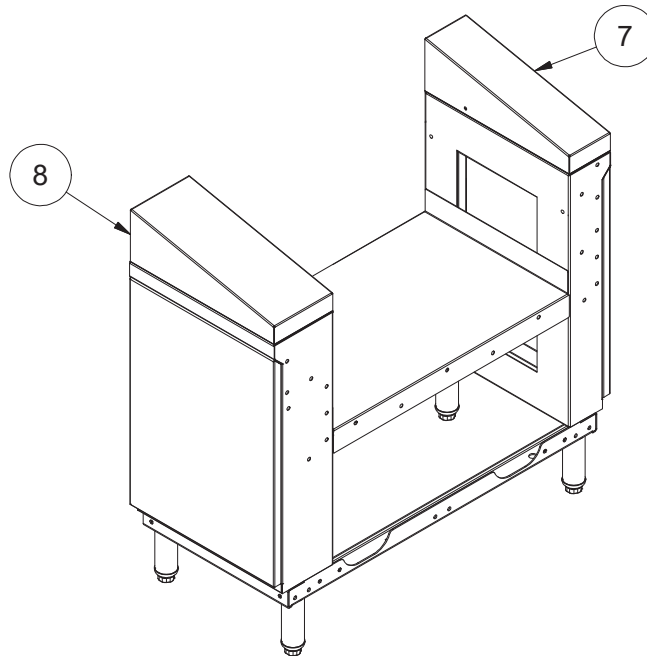

ITEM	QTY	DESCRIPTION	PART NUMBER
1	1	Tank	05700-004-80-37
2	1	Base	05700-004-80-40
3	2	Side Dress Panel	05700-004-80-41
4	4	Conveyor Rail, 18" Unload Expansion	05700-004-81-55
5	1	Riser, Rear Straight	05700-004-81-44
6	1	Riser, Front Straight	05700-004-81-42
7	1	Riser, Rear Angled, L-R Riser, Rear Angled, R-L	05700-004-81-47 05700-004-81-51
8	1	Riser, Front Angled, L-R Riser, Front Angled, R-L	05700-004-81-45 05700-004-81-49

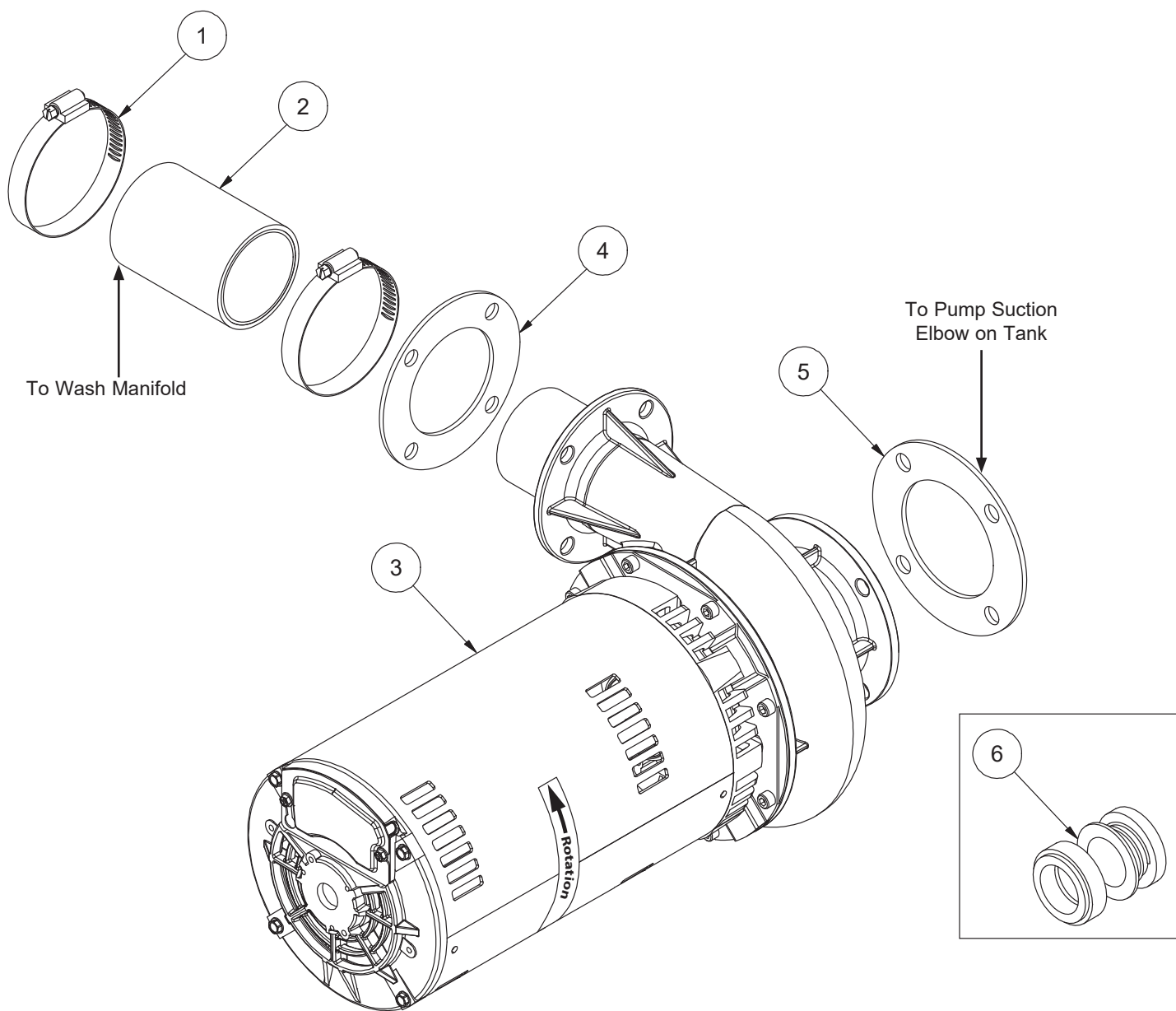

ITEM	QTY*	DESCRIPTION	PART NUMBER
1	2	Hose Clamp, 2 9/16" to 3 1/2"	04730-003-15-40
2	1	Drain Hose, 2 1/2" ID	05700-004-67-02
3	1	Pump & Motor Assembly, 3 HP	06105-004-56-23
4	1	Pump Discharge Gasket	05330-003-75-88
5	1	Pump Suction Gasket	05330-003-75-87
6	1	Pump Seal	05330-002-34-22

\*Each section (Pre-wash, Wash, and Power Rinse) contains the complete assembly shown above.

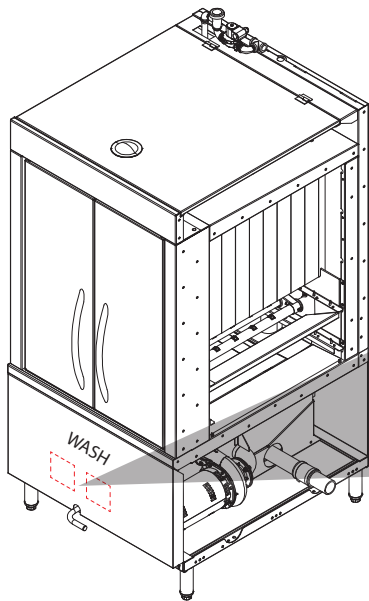

**Wash**

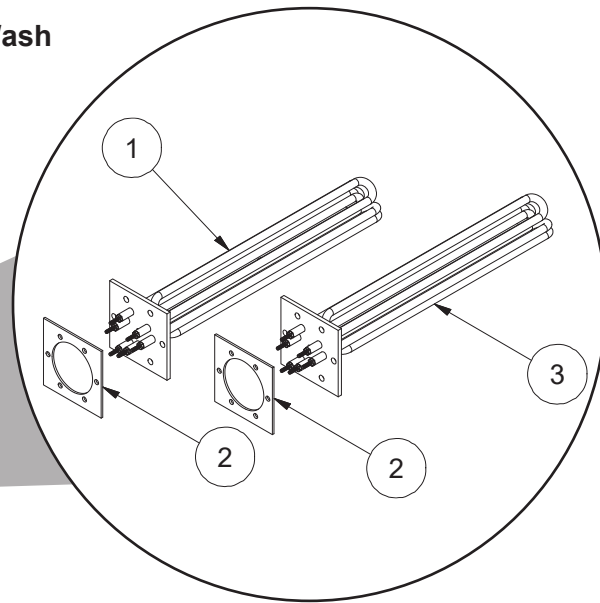

ITEM	QTY	DESCRIPTION	PART NUMBER
1	1	Heater, 12 kW, 208 V Heater, 12 kW, 230 V Heater, 12 kW, 460 V	04540-004-56-21 04540-004-79-53 04540-004-79-54
2	2	Heater Gasket	05330-200-02-70
3	1	Heater, 15 kW, 208 V Heater, 15 kW, 230 V Heater, 15 kW, 460 V	04540-121-68-45 04540-121-68-46 04540-121-68-47

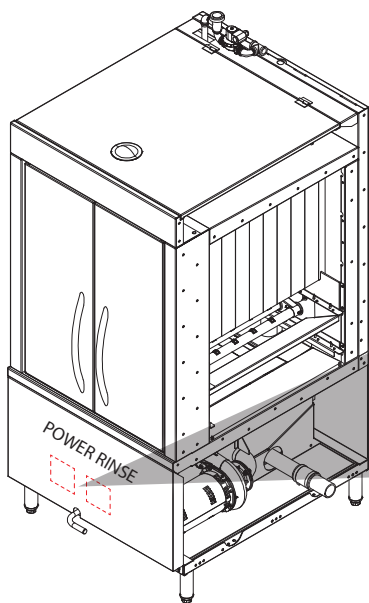

**Power Rinse**

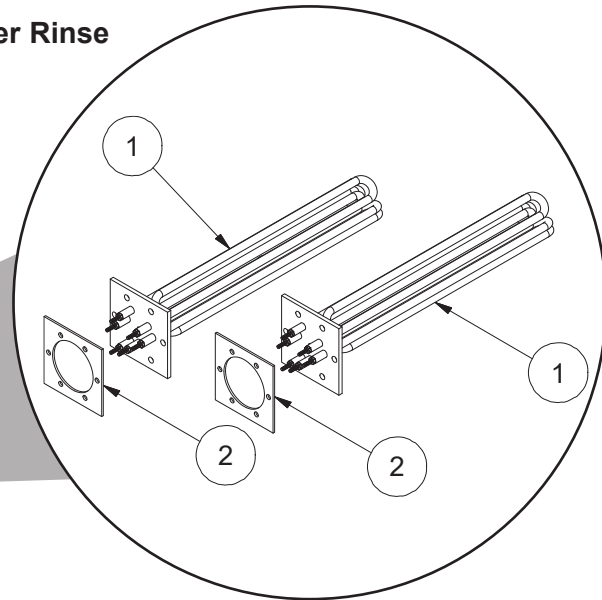

ITEM	QTY	DESCRIPTION	PART NUMBER
1	2	Heater, 15 kW, 208 V Heater, 15 kW, 230 V Heater, 15 kW, 460 V	04540-121-68-45 04540-121-68-46 04540-121-68-47
2	2	Heater Gasket	05330-200-02-70

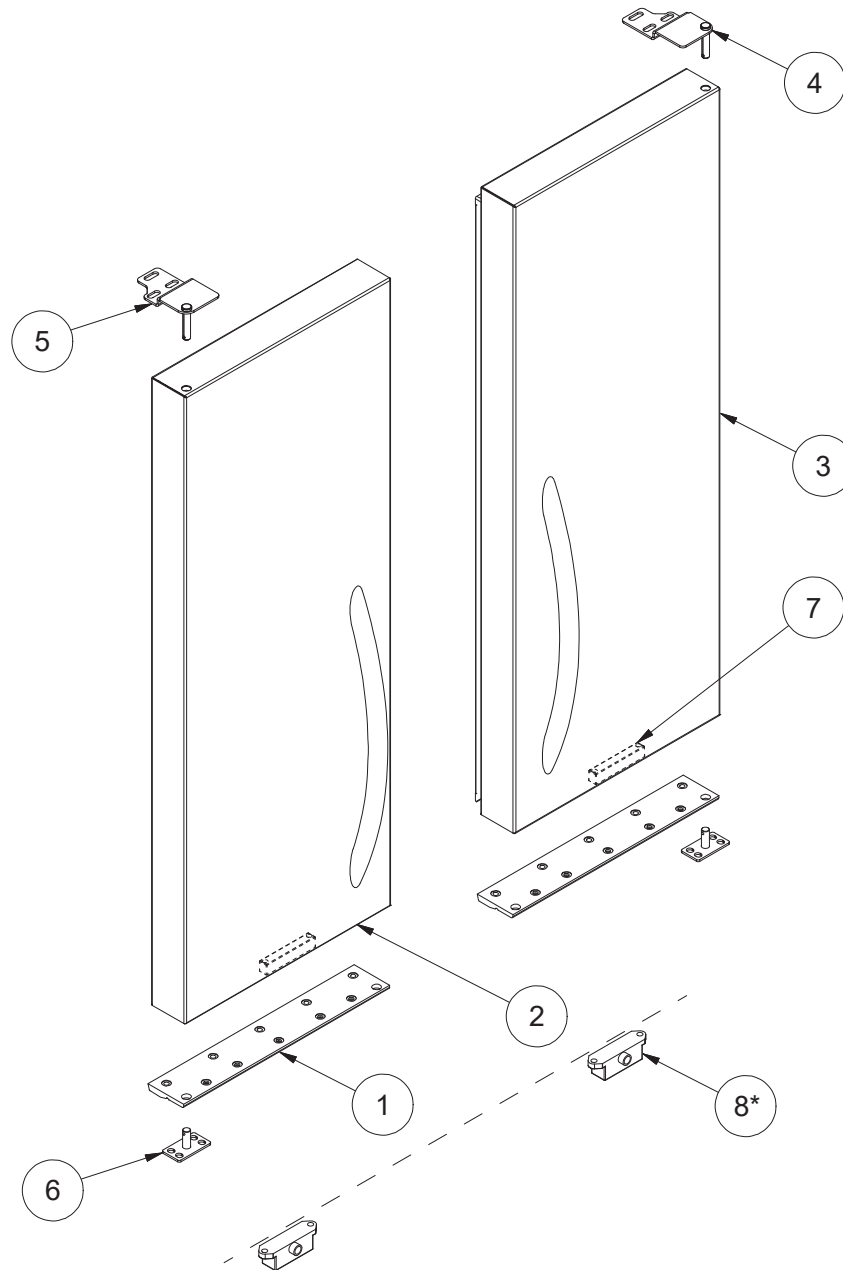

ITEM	QTY	DESCRIPTION	PART NUMBER
1	1	Door Block (included in door assembly)	05700-004-31-36
2	1	Door Assembly, Left	05700-004-72-25
3	1	Door Assembly, Right	05700-004-72-30
4	1	Door Hinge, Right	05700-004-16-57
5	1	Door Hinge, Left	05700-004-16-56
6	2	Door Hinge Pin, Bottom	05700-004-62-22
7	2	Magnet, 3/8" x 2 1/2" (included in door assembly)	05930-111-51-68
8*	2	Switch, Door Safety	05930-002-36-80

\*Located on machine frame under door.

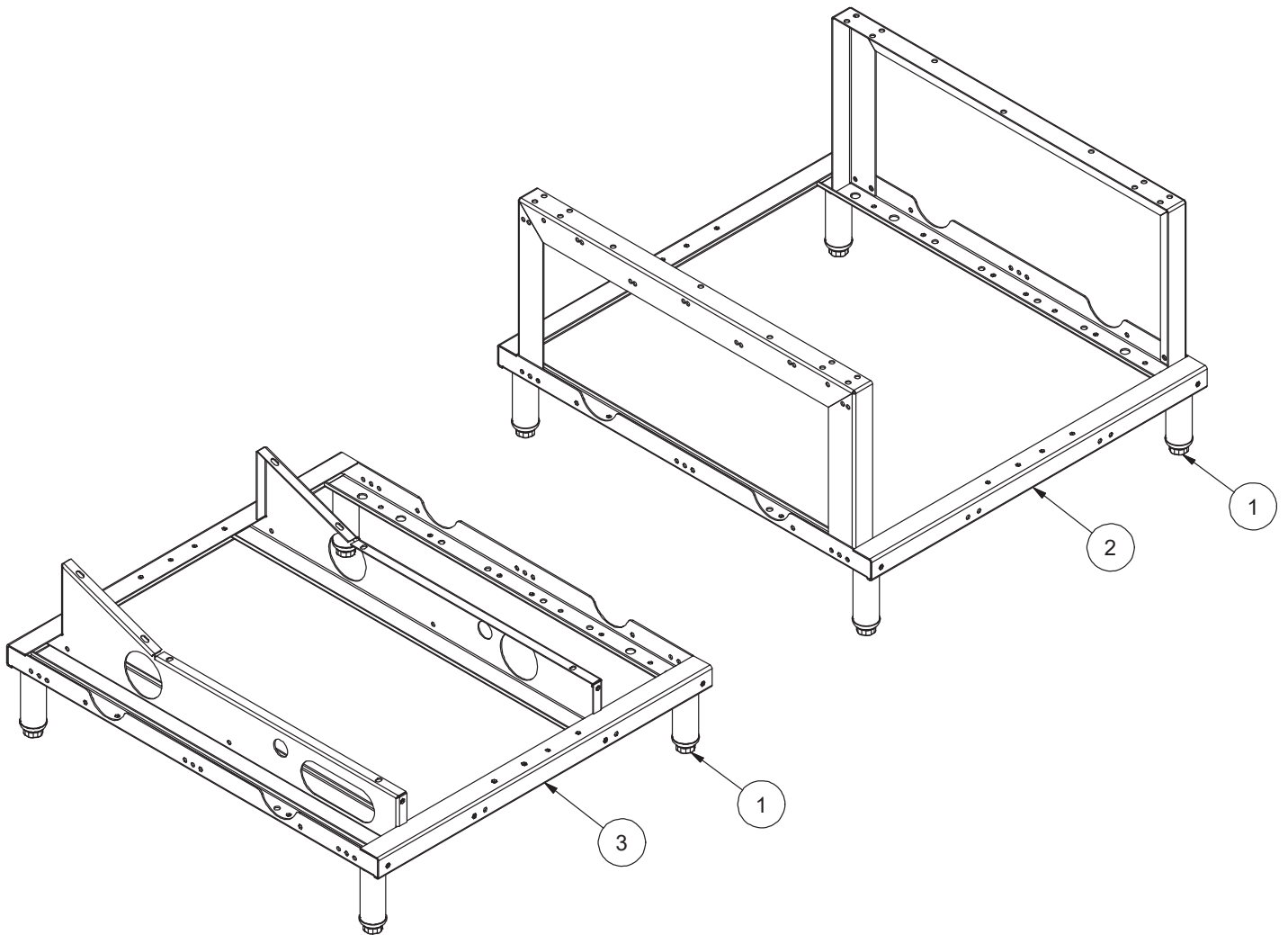

ITEM	QTY	DESCRIPTION	PART NUMBER
1	4 per	Adjustable Foot Flanged Foot	05340-011-71-74 05340-002-15-47
2	1	Frame, Blower/Dryer Section Frame, Electrical Section (Not Shown)	05700-004-77-63 05700-004-62-76
3	1	Frame, Pre-Wash/Wash/Power Rinse Sections	05700-004-56-90
4	1	Frame, Load Expansion (Not Shown)	05700-004-81-58

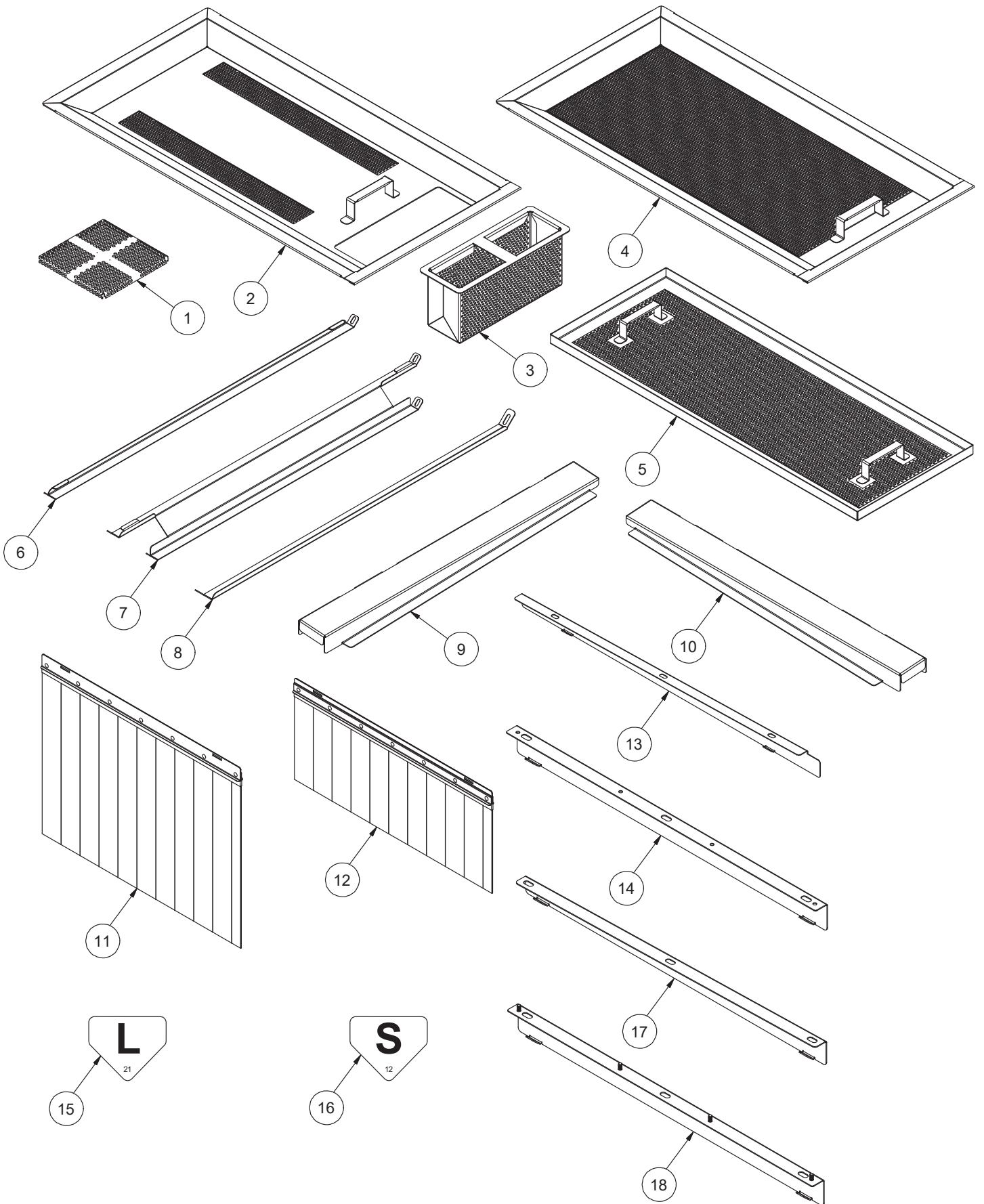

ITEM	QTY	DESCRIPTION	PART NUMBER
1	1	Strainer, Load Strainer, Unload Retainer, Strainer, Load and Unload (Not Shown)	05700-003-22-99 05700-004-73-25 05700-004-65-46
2	1	Pan Strainer, Pre-wash	05700-004-62-02
3	1	Scrap Basket, Pre-wash	05700-004-61-64
4	1 per	Pan Strainer, Wash/Power Rinse	05700-004-62-03
5	2 1	Pan Strainer, Load Pan Strainer, Load Expansion	05700-004-75-66
6	1	Screen Rail One, Load	05700-004-65-51
7	1	Screen Rail Two, Load	05700-004-65-52
8	1	Screen Rail Three, Load	05700-004-65-53
9	1 per	Strainer Support, Side, Pre-Wash/Wash, L-R & R-L Strainer Support, Side, Pre-Wash/Wash, L-R & R-L	05700-004-61-59 05700-004-61-60
10	1 per	Strainer Support, Side, Power Rinse, L-R Strainer Support, Side, Power Rinse, L-R <hr/> Strainer Support, Side, Power Rinse, R-L Strainer Support, Side, Power Rinse, R-L	05700-004-92-88 05700-004-92-87 <hr/> 05700-004-61-60 05700-004-85-46
11	1 per	Curtain, Long	05700-002-79-70
12	1 per	Curtain, Short	05700-002-86-00
13	2 per	Curtain Holder, Load, Pre-Wash/Wash/Power Rinse, L-R Curtain Holder, Load, Pre-Wash/Wash/Power Rinse, R-L	05700-004-72-01 05700-004-76-06
14	1	Curtain Holder, Blower/Dryer Middle	05700-004-75-65
15	1 per	Decal, Long Curtain	09905-004-38-07
16	1 per	Decal, Short Curtain	09905-004-38-05
17	3	Curtain Holder, Controls, L-R Curtain Holder, Controls, R-L	05700-004-63-59 05700-004-63-60
18	1	Curtain Holder, Blower/Dryer Unload End	05700-004-75-26

LEGEND 208/230/460 VAC 60Hz 3-PHASE

TB1-TB4	POWER DISTRIBUTION BLOCKS	S11	SWITCH, DOOR 2 PREWASH SECTION
GND	EARTH GROUND	S12	SWITCH, DOOR 1 WASH SECTION
H1	HEATER 1, WASH 208 VOLTS, 12KW	S13	SWITCH, DOOR 2 WASH SECTION
H2	HEATER 2, WASH 208 VOLTS, 12KW	S14	SWITCH, DOOR 1 POWER RINSE SECTION
H3	HEATER 1, RINSE 208 VOLTS, 12KW	S15	SWITCH, DOOR 2 POWER RINSE SECTION
H4	HEATER 2, RINSE 208 VOLTS, 14KW	S16	SWITCH, COVER
H5	HEATER, BLOWER 208 VOLTS, 9KW (OPTION)	S17	SWITCH, DOOR 1 BLOWER DRYER (OPTIONAL)
M1	MOTOR, WASH PUMP 208 VOLTS, 3HP, 2.5A	S18	SWITCH, DOOR 2 BLOWER DRYER (OPTIONAL)
M2	MOTOR, POWER RINSE PUMP 208 VOLTS, 6.8A	S19	SWITCH, DRIVE-MOTOR SPEED SELECTOR
M3	MOTOR, EXHAUST FAN 208 VOLTS, .42HP, 1.0A	S21	SWITCH, DRIVE-MOTOR JAM
M4	MOTOR, PREWASH PUMP 208 VOLTS, 3HP, 8.5A	S22	SWITCH, SLIDE-STOP
M5	MOTOR, BLOWER (OPTION)	S23	SWITCH, MANUAL/AUTOMATIC MODE
M6	MOTOR, DRIVE 208 VOLTS, .25HP, 1.4A	SNS1	SENSOR, TEMPERATURE, PREWASH
HC1	CONTACTOR 1, WASH HEATER	SNS2	SENSOR, TEMPERATURE, WASH
HC2	CONTACTOR 2, WASH HEATER	SNS3	SENSOR, TEMPERATURE, POWER RINSE
HC3	CONTACTOR 1, RINSE HEATER	SNS4	SENSOR, TEMPERATURE, FINAL RINSE
HC4	CONTACTOR 2, RINSE HEATER	SNS5	SENSOR, WATER PRESSURE, FINAL RINSE
HC5	CONTACTOR, BLOWER HEATER (OPTION)	TS1	THERMOSTAT, HIGH LIMIT, WASH
MC1	CONTACTOR, WASH PUMP MOTOR	TS2	THERMOSTAT, HIGH LIMIT, POWER RINSE
MC2	CONTACTOR, POWER RINSE PUMP MOTOR	TS3	THERMOSTAT, HIGH LIMIT, INTERNAL EXHAUST FAN
MC3	CONTACTOR, EXHAUST FAN MOTOR	TS4	THERMOSTAT, HIGH LIMIT, INTERNAL BLOWER MOTOR
MC4	CONTACTOR, PREWASH PUMP MOTOR	TS5	THERMOSTAT, HIGH LIMIT, BLOWER HEATER
MC5	CONTACTOR, BLOWER MOTOR (OPTION)	OL1	OVERLOAD RELAY, WASH PUMP MOTOR
MC6	CONTACTOR, DRIVE MOTOR, LOW SPEED	OL2	OVERLOAD RELAY, POWER RINSE PUMP MOTOR
MC7	CONTACTOR, DRIVE MOTOR, HIGH SPEED	OL3	OVERLOAD RELAY, EXHAUST FAN MOTOR
MC8	CONTACTOR, DRIVE MOTOR REVERSER	OL4	OVERLOAD RELAY, PREWASH PUMP MOTOR
R1	RELAY, PREWASH TANK FILL	OL5	OVERLOAD RELAY, BLOWER MOTOR (OPTION)
R2	RELAY, WASH TANK FILL	OL6	OVERLOAD RELAY, DRIVE MOTOR HIGH SPEED
R3	RELAY, POWER RINSE TANK FILL	OL7	OVERLOAD RELAY, DRIVE MOTOR LOW SPEED
R4	RELAY, BOOSTER CONTROL POWER	OL8	OVERLOAD RELAY, DRIVE MOTOR REVERSER
R5	RELAY, PREWASH PUMP SAFETY	FSPW1	FLOAT SWITCH, PREWASH TOP
R6	RELAY, WASH PUMP SAFETY	FSPW2	FLOAT SWITCH, PREWASH BOTTOM
R7	RELAY, POWER RINSE PUMP SAFETY	FSW1	FLOAT SWITCH, WASH TOP
SFR	SOLENOID, FINAL RINSE	FSW2	FLOAT SWITCH, WASH BOTTOM
SPWF	SOLENOID, PREWASH TANK FILL	FSPR1	FLOAT SWITCH, POWER RINSE TOP
SWF	SOLENOID, WASH TANK FILL	FSPR2	FLOAT SWITCH, POWER RINSE BOTTOM
SPRF	SOLENOID, POWER RINSE TANK FILL	PE1	PHOTO EYE, EMITTER
SK	SWITCH, KEYED (OPTION)	PE2	PHOTO EYE, RECEIVER
S1	SWITCH, MAIN POWER ON/OFF (MAINTAINED, LIGHTED)	E1	LAMP, RUN MODE, LOAD SECTION
S2	SWITCH, START, MAIN CONTROL SECTION (LIGHTED)	E2	LAMP, RUN MODE, CONTROL SECTION
S3	SWITCH, START, LOAD SECTION (LIGHTED)	E3	LAMP, RUN MODE, UNLOAD SECTION
S4	SWITCH, START, UNLOAD SECTION (LIGHTED)	T1	TRANSFORMER, CONTROL
S5	SWITCH, STOP MAIN CONTROL SECTION	F1	FUSE, CONTROL 2A/250VAC, SLOW-ACTING
S6	SWITCH, STOP LOAD SECTION	F2	FUSE, RINSE AID 0.2A/250VAC, SLOW-ACTING
S7	SWITCH, STOP UNLOAD SECTION	F3	FUSE, DETERGENT 0.2A/250VAC, SLOW-ACTING
S8	SWITCH, TURBO RINSE (MAINTAINED, LIGHTED)	F4	FUSE, EXT FAN CDN 0.2A/250VAC, SLOW-ACTING
S9	SWITCH, DELIME (MAINTAINED, LIGHTED)	F5	FUSE, CONSTANT VOLTAGE 0.5A/250VAC, SLOW-ACTING
S10	SWITCH, DOOR 1 PREWASH SECTION	F6	FUSE, PREWASH FAN 0.2A/250VAC, SLOW-ACTING
		F7	FUSE, WASH FAN 0.2A/250VAC, SLOW-ACTING
		F8	FUSE, POWER RINSE 0.2A/250VAC, SLOW-ACTING

NOTES

- R4 IS TO BE INSERTED BETWEEN THE TRANSFORMER & POWER SWITCH OF THE EXISTING BOOSTER WIRING. POWER SWITCH REMAINS IN "ON" POSITION.
- HIGH-LIMIT SWITCH USES WHITE LEADS, WHICH CONNECT TO COLORED MACHINE WIRING AS SHOWN.
- IF BELT IS FUNCTIONING IN REVERSE OF NORMAL OPERATION, SWAP RED AND BLACK WIRES ON MOTOR CONTACTOR (M6)
- IF MULTIPLE PREWASH SECTIONS ARE ADDED, ALL PREWASH DOOR SWITCHES AND FLOAT SWITCHES WILL BE WIRED IN SERIES
- IF MULTIPLE BLOWER DRYER SECTIONS ARE ADDED, ALL BLOWER DRYER DOOR SWITCHES AND THERMOSTATS WILL BE WIRED IN SERIES
- S23 IS USED TO OPERATE THE MACHINE BASED OFF OF EITHER THE PHOTOEYE SIGNAL(AUTOMATIC) OR A CONSTANT SIGNAL FROM L1 FROM THE TRANSFORMER (MANUAL)

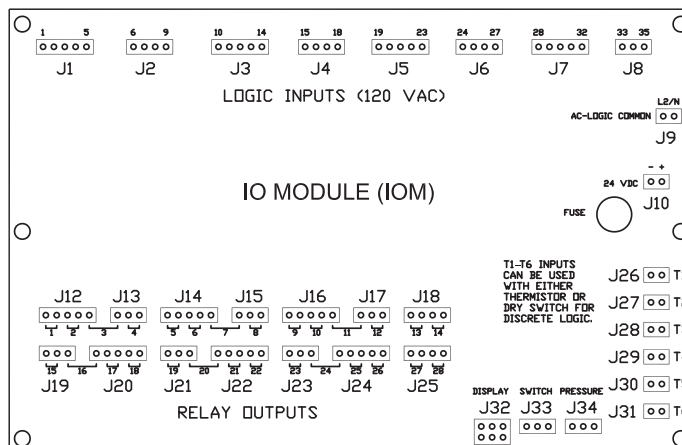



Previous Page

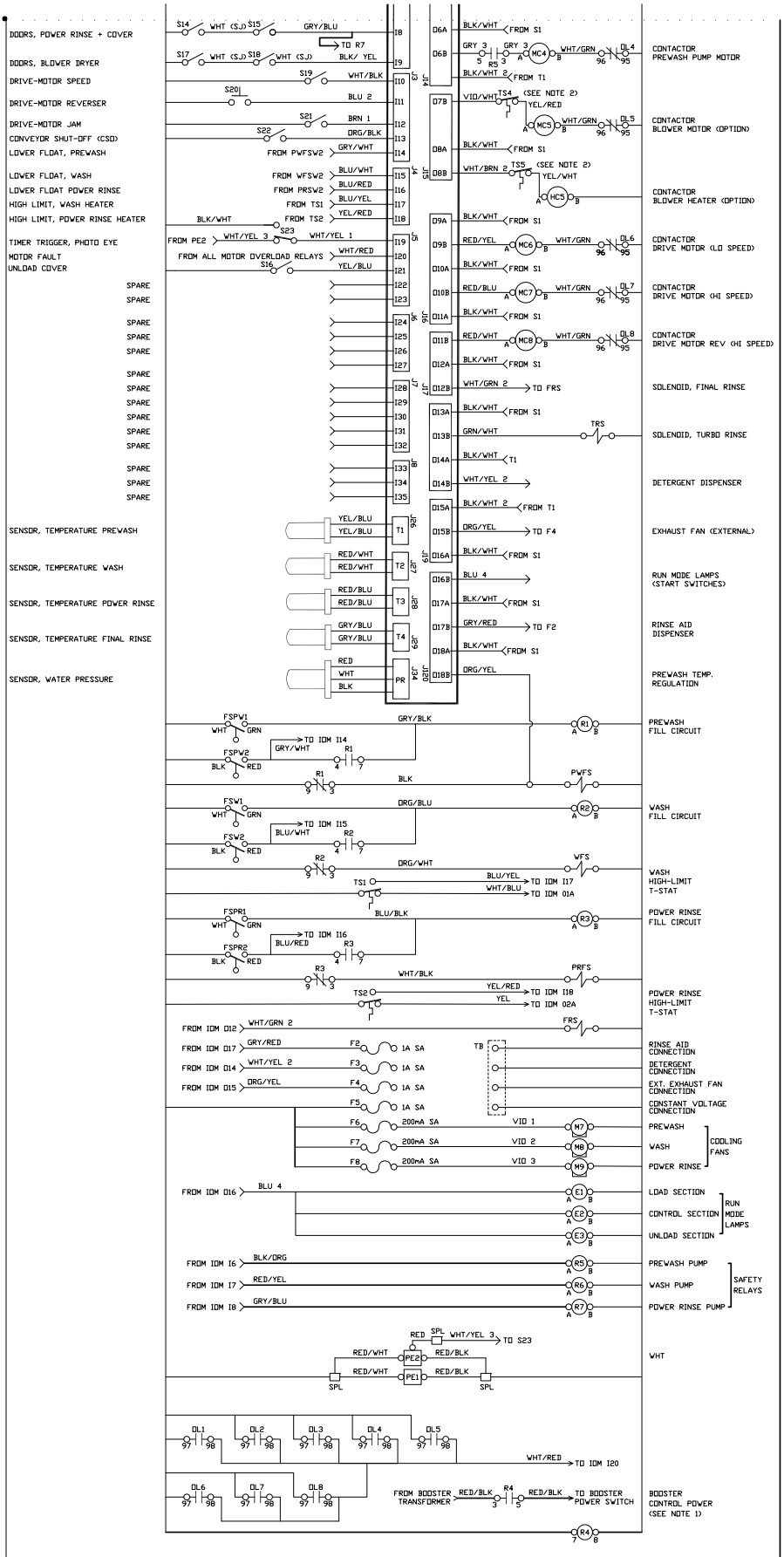

09905-004-60-42 REV. K

LEGEND 208/230/460 VAC 60Hz 3-PHASE

TB1-TB4	POWER DISTRIBUTION BLOCKS	S21	SWITCH, DRIVE-MOTOR JAM
GND	EARTH GROUND	S22	SWITCH, SLIDE-STOP
M1	MOTOR, WASH PUMP 208 VOLTS, 3HP, 2.5A	S23	SWITCH, MANUAL/AUTOMATIC
M2	MOTOR, POWER RINSE PUMP 208 VOLTS, 6.8A	SNS1	SENSOR, TEMPERATURE, PREWASH
M3	MOTOR, EXHAUST FAN 208 VOLTS, .42HP, 1.0A	SNS2	SENSOR, TEMPERATURE, WASH
M4	MOTOR, PREWASH PUMP 208 VOLTS, 3HP, 8.5A	SNS3	SENSOR, TEMPERATURE, POWER RINSE
M5	MOTOR, BLOWER (OPTION)	SNS4	SENSOR, TEMPERATURE, FINAL RINSE
M6	MOTOR, DRIVE 208 VOLTS, .25HP, 1.4A	SNS5	SENSOR, WATER PRESSURE, FINAL RINSE
MC1	CONTACTOR, WASH PUMP MOTOR	DL1	OVERLOAD RELAY, WASH PUMP MOTOR
MC2	CONTACTOR, POWER RINSE PUMP MOTOR	DL2	OVERLOAD RELAY, POWER RINSE PUMP MOTOR
MC3	CONTACTOR, EXHAUST FAN MOTOR	DL3	OVERLOAD RELAY, EXHAUST FAN MOTOR
MC4	CONTACTOR, PREWASH PUMP MOTOR	DL4	OVERLOAD RELAY, PREWASH PUMP MOTOR
MC5	CONTACTOR, BLOWER MOTOR (OPTION)	DL5	OVERLOAD RELAY, BLOWER MOTOR (OPTION)
MC6	CONTACTOR, DRIVE MOTOR, LOW SPEED	DL6	OVERLOAD RELAY, DRIVE MOTOR HIGH SPEED
MC7	CONTACTOR, DRIVE MOTOR, HIGH SPEED	DL7	OVERLOAD RELAY, DRIVE MOTOR LOW SPEED
MC8	CONTACTOR, DRIVE MOTOR REVERSER	DL8	OVERLOAD RELAY, DRIVE MOTOR REVERSER
R1	RELAY, PREWASH TANK FILL	FSPW1	FLOAT SWITCH, PREWASH TOP
R2	RELAY, WASH TANK FILL	FSPW2	FLOAT SWITCH, PREWASH BOTTOM
R3	RELAY, POWER RINSE TANK FILL	FSW1	FLOAT SWITCH, WASH TOP
R4	RELAY, BOOSTER CONTROL POWER	FSW2	FLOAT SWITCH, WASH BOTTOM
R5	RELAY, PREWASH PUMP SAFETY	FSPR1	FLOAT SWITCH, POWER RINSE TOP
R6	RELAY, WASH PUMP SAFETY	FSPR2	FLOAT SWITCH, POWER RINSE BOTTOM
R7	RELAY, POWER RINSE PUMP SAFETY	PE1	PHOTO EYE, EMITTER
SFR	SOLENOID, FINAL RINSE	PE2	PHOTO EYE, RECEIVER
SPWF	SOLENOID, PREWASH TANK FILL	E1	LAMP, RUN MODE, LOAD SECTION
SWF	SOLENOID, WASH TANK FILL	E2	LAMP, RUN MODE, CONTROL SECTION
SPRF	SOLENOID, POWER RINSE TANK FILL	E3	LAMP, RUN MODE, UNLOAD SECTION
SK	SWITCH, KEYED (OPTION)	T1	TRANSFORMER, CONTROL
S1	SWITCH, MAIN POWER ON/OFF (MAINTAINED, LIGHTED)	F1	FUSE, CONTROL 2A/250VAC, SLOW-ACTING
S2	SWITCH, START, MAIN CONTROL SECTION (LIGHTED)	F2	FUSE, RINSE AID 0.2A/250VAC, SLOW-ACTING
S3	SWITCH, START, LOAD SECTION (LIGHTED)	F3	FUSE, DETERGENT 0.2A/250VAC, SLOW-ACTING
S4	SWITCH, START, UNLOAD SECTION (LIGHTED)	F4	FUSE, EXT FAN CON 0.2A/250VAC, SLOW-ACTING
S5	SWITCH, STOP MAIN CONTROL SECTION	F5	FUSE, CONSTANT VOLTAGE 0.5A/250VAC, SLOW-ACTING
S6	SWITCH, STOP LOAD SECTION	F6	FUSE, PREWASH 0.2A/250VAC, SLOW-ACTING
S7	SWITCH, STOP UNLOAD SECTION	F7	FUSE, WASH FAN 0.2A/250VAC, SLOW-ACTING
S8	SWITCH, TURBO RINSE (MAINTAINED, LIGHTED)	F8	FUSE, POWER RINSE FAN 0.2A/250VAC, SLOW-ACTING
S9	SWITCH, DELIME (MAINTAINED, LIGHTED)	WSS	SOLENOID, WASH STEAM COIL
S10	SWITCH, DOOR 1 PREWASH SECTION	PRSS	SOLENOID, POWER RINSE STEAM COIL
S11	SWITCH, DOOR 2 PREWASH SECTION	BHSS	SOLENOID, STEAM BLOWER HEATER (OPTION)
S12	SWITCH, DOOR 1 WASH SECTION	BSS	SOLENOID, STEAM BOOSTER HEATER
S13	SWITCH, DOOR 2 WASH SECTION	TS1	BOOSTER THERMOSTAT
S14	SWITCH, DOOR 1 POWER RINSE SECTION		
S15	SWITCH, DOOR 2 POWER RINSE SECTION		
S16	SWITCH, COVER		
S17	SWITCH, DOOR 1 BLOWER DRYER (OPTIONAL)		
S18	SWITCH, DOOR 2 BLOWER DRYER (OPTIONAL)		
S19	SWITCH, DRIVE-MOTOR SPEED SELECTOR		

NOTES

- R4 IS TO BE INSERTED BETWEEN THE L1 AND THE COMMON ON THE BOOSTER THERMOSTAT
- HIGH-LIMIT SWITCH USES WHITE LEADS, WHICH CONNECT TO COLORED MACHINE WIRING AS SHOWN.
- IF BELT IS FUNCTIONING IN REVERSE OF NORMAL OPERATION, SWAP RED AND BLACK WIRES ON MOTOR CONTACTOR (M6)
- IF MULTIPLE PREWASH SECTIONS ARE ADDED, ALL PREWASH DOOR SWITCHES AND FLOAT SWITCHES WILL BE WIRED IN SERIES
- IF MULTIPLE BLOWER DRYER SECTIONS ARE ADDED, ALL BLOWER DRYER DOOR SWITCHES AND THERMOSTATS WILL BE WIRED IN SERIES
- S23 IS USED TO OPERATE THE MACHINE BASED OFF OF EITHER THE PHOTOEYE SIGNAL(AUTOMATIC) OR A CONSTANT SIGNAL FROM L1 FROM THE TRANSFORMER (MANUAL)

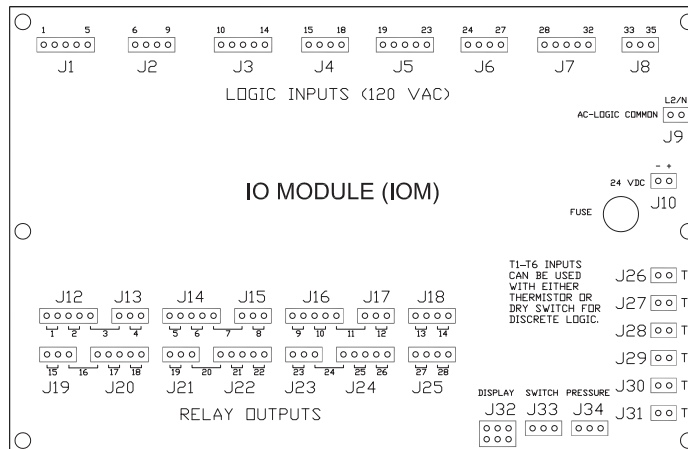

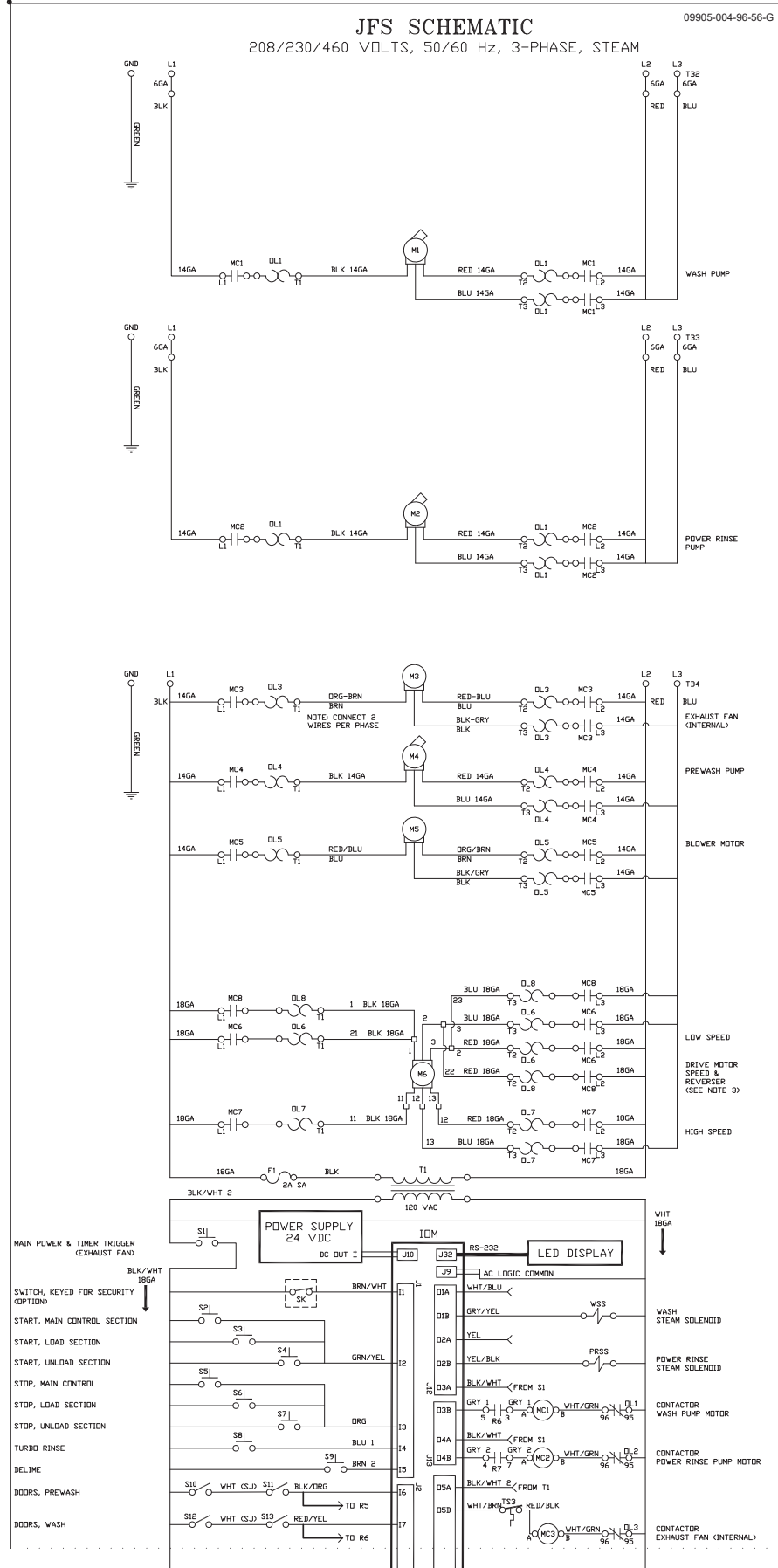

Next Page





Jackson WWS, Inc. • 6209 N. US Hwy 25E • Gray, KY 40734 USA  
1.888.800.5672 • [www.jacksonwws.com](http://www.jacksonwws.com)