



Warewashing Systems

INSTALLATION, OPERATION, AND SERVICE MANUAL



DISHSTAR[®] HT/LT

DISHSTAR SERIES UNDERCOUNTER DISHMACHINES

DishStar HT/LT Manual • 07610-004-37-13-R

**MANUFACTURER'S LIMITED WARRANTY
(APPLICABLE ONLY IN THE UNITED STATES AND CANADA)**

WARRANTY REGISTRATION:

To register your Jackson Dishmachine's warranty go to jacksonwws.com/warranty or call 1-888-800-5672. Failure to register the Dishmachine will void the warranty.

ONE YEAR LIMITED PARTS AND LABOR WARRANTY

For a period of one (1) year from date of original installation of a new Jackson Dishmachine (but in no event to exceed eighteen (18) months from date of shipment from Jackson's factory), Jackson WWS, Inc. (Jackson) will repair or replace, at its discretion, any original part that proves defective in materials or workmanship at the time the Dishmachine was purchased; provided that (i) the Dishmachine has not been altered, (ii) the Dishmachine has been properly installed, maintained, and operated under normal use conditions and in accordance with the applicable installation, operation and service manual available on the Jackson website, and (iii) a warranty claim is reported to a Jackson Authorized Service Agency within the warranty period. This warranty includes replacement with Jackson specified genuine replacement parts, purchased directly from a Jackson Authorized Parts Distributor or Service Agency. Use of generic replacement parts may create a hazard and shall void this warranty.

THIS WARRANTY DOES NOT APPLY OUTSIDE THE UNITED STATES AND CANADA.

Jackson will pay the labor to repair or replace a defective original part as a part of the warranty, provided that a Jackson Authorized Service Agency performs the labor. Any repair or replacement work by anyone other than a Jackson Authorized Service Agency is the sole responsibility of the purchaser. Labor coverage is limited to regular hourly rates; Jackson will not pay overtime premiums or emergency service charges.

Accessory components (such as table limit switches, pressure regulators, and drain water tempering kits) that are not installed by Jackson at the factory and are shipped with the Dishmachine carry only a (1) one-year parts warranty. Labor to repair or replace these components is not included in the warranty or covered by Jackson. Booster heaters not manufactured by Jackson are not covered by this warranty but are warranted by their respective manufacturers.

This warranty is void if any defect or failure is a direct result from shipping, handling, fire, water, accident, alteration, modification, misuse, abuse, flood, acts of God, burglary, casualty, attempted repair by unauthorized persons, use of replacement parts not authorized by Jackson, improper installation, installation not in accordance with local electrical and plumbing codes, if the serial number has been removed or altered, if the Dishmachine is used for any purpose other than originally intended, or if the equipment is installed for residential use.

Jackson does not authorize any other entity or person, including, without limitation, any entity or person who deals in Jackson Dishmachines, to change this warranty or create any other obligation in connection with Jackson Dishmachines.

TRAVEL LIMITATIONS:

Jackson limits warranty travel time to the customer site within 50 miles of the Jackson authorized service agent's office and during regular business hours. Jackson will not pay for travel time and mileage that exceeds these limits, or any fees such as those for air or boat travel without prior authorization.

REPLACEMENT PARTS WARRANTY:

For a period of (90) ninety days from the date of installation by a Jackson Authorized Service Agency (but in no event to exceed (180) one-hundred-eighty days from the date of purchase from a Jackson Authorized Parts Distributor or Service Agency), Jackson will repair or replace, at its discretion, any Jackson genuine replacement parts that prove defective in materials or workmanship at the time the replacement parts were installed. This warranty does not include paying the labor to repair or replace the replacement part. This warranty is subject to all conditions, exclusions and limitations applicable to the Dishmachine.

**MANUFACTURER'S LIMITED WARRANTY (CONT.)
(APPLICABLE ONLY IN THE UNITED STATES AND CANADA)**

PRODUCT CHANGES:

Jackson reserves the right to make changes in design and specification of any component of the Dishmachine as engineering or necessity requires.

DISCLAIMER OF WARRANTIES:

THERE ARE NO WARRANTIES, EXPRESSED OR IMPLIED, INCLUDING, WITHOUT LIMITATION, ANY IMPLIED WARRANTY OF FITNESS FOR A PARTICULAR PURPOSE OR MERCHANTABILITY, THAT ARE NOT SET FORTH HEREIN, OR THAT EXTEND BEYOND THE DURATION HEREOF.

LIMITATION OF REMEDIES AND LIABILITIES:

YOUR SOLE AND EXCLUSIVE REMEDY UNDER THIS LIMITED WARRANTY SHALL BE PRODUCT REPAIR OR REPLACEMENT AS PROVIDED HEREIN.

UNDER NO CIRCUMSTANCES WILL JACKSON BE LIABLE FOR ANY INCIDENTAL OR CONSEQUENTIAL DAMAGES, OR FOR DAMAGES IN THE NATURE OF PENALTIES. JACKSON'S LIABILITY ON ANY CLAIM OF ANY KIND WITH RESPECT TO THE GOODS OR SERVICES COVERED HEREUNDER SHALL IN NO CASE EXCEED THE PRICE OF THE GOODS OR SERVICES OR PART THEREOF WHICH GIVES RISE TO THE CLAIM.

ITEMS NOT COVERED:

THIS WARRANTY DOES NOT COVER (1) ADJUSTMENTS INCLUDING, BUT NOT LIMITED TO, TIMER CAMS, THERMOSTATS, DOORS, TANK HEATER ADJUSTMENTS OR CLUTCHES; (2) AIR FREIGHT OR OVERNIGHT FREIGHT; (3) ANY AMOUNT EXCEEDING ORIGINAL PURCHASE PRICE; (4) CLEANING OF DRAIN VALVES, GAS LINES, RINSE/WASH NOZZLES, STRAINERS, SCREENS, OR SPRAY PIPES; (5) CLEANING OR DELIMING OF THE DISHMACHINE OR ANY COMPONENT INCLUDING, BUT NOT LIMITED TO, WASH ARMS, RINSE ARMS AND STRAINERS; (6) CONDITIONS CAUSED BY THE USE OF INCORRECT (NON-COMMERCIAL) GRADE DETERGENTS; (7) CORROSION FROM CHEMICALS DISPENSED IN EXCESS OF RECOMMENDED CONCENTRATIONS; (8) COSMETIC DAMAGE, INCLUDING BUT NOT LIMITED TO, SCRATCHES, DENTS, CHIPS, AND OTHER DAMAGE TO THE DISHMACHINE FINISHES, UNLESS SUCH DAMAGE RESULTS FROM DEFECTS IN MATERIALS AND WORKMANSHIP AND IS REPORTED TO JACKSON WITHIN (30) THIRTY DAYS FROM THE DATE OF INSTALLATION; (9) DAMAGE CAUSED BY LABOR DISPUTE; (10) DAMAGES RESULTING FROM IMPROPER CONNECTION TO UTILITY SERVICE; (11) DAMAGES RESULTING FROM WATER CONDITIONS, INADEQUATE OR EXCESSIVE WATER PRESSURE, ACCIDENTS, ALTERATIONS, IMPROPER USE, ABUSE, HANDLING, OVERLOADS, TAMPERING, IMPROPER INSTALLATION OR FAILURE TO FOLLOW MAINTENANCE AND OPERATING PROCEDURES; (12) DISCOLORATION, RUST OR OXIDATION OF SURFACES RESULTING FROM CAUSTIC OR CORROSIVE ENVIRONMENTS, INCLUDING, BUT NOT LIMITED TO, HIGH SALT CONCENTRATIONS, HIGH MOISTURE OR HUMIDITY, OR EXPOSURE TO CHEMICALS; (13) ELECTRIC BOOSTERS, FEED LINES, FLEX HOSE, FUSES, GARBAGE DISPOSALS, OR GAS PILOTS; (14) EXCESSIVE LIME, MINERAL, OR ALKALINE BUILDUP; (15) EXPENSES DUE TO DISCONNECTION, DELIVERY, RETURN AND REINSTALLATION; (16) FAILURE OF ELECTRICAL COMPONENTS DUE TO CONNECTION OF CHEMICAL DISPENSING EQUIPMENT INSTALLED BY OTHERS; (17) FAILURE OF FACILITY WATER HEATER TO MAKE TEMPERATURE; (18) FAILURE TO MAINTAIN WATER HARDNESS LOWER THAN 3.0 GRAINS, PH BETWEEN 7.0 AND 8.5 AND TOTAL DISSOLVED SOLIDS BELOW 250 PPM; (19) FAILURE TO COMPLY WITH LOCAL ELECTRICAL BUILDING CODES; (20) LEAKS OR DAMAGE RESULTING FROM SUCH LEAKS CAUSED BY THE INSTALLER, INCLUDING THOSE AT MACHINE TABLE CONNECTIONS, OR BY CONNECTION OF CHEMICAL DISPENSING EQUIPMENT INSTALLED BY OTHERS; (21) OPENING OR CLOSING OF UTILITY SUPPLY VALVES OR SWITCHING OF ELECTRICAL SUPPLY CURRENT; (22) PERFORMANCE OF REGULAR MAINTENANCE AND CLEANING AS OUTLINED IN THE OPERATOR'S GUIDE; (23) REMOVAL OR REINSTALLATION OF INACCESSIBLE DISHMACHINES OR BUILT-IN FIXTURES THAT INTERFERE WITH SERVICING, REMOVAL OR REPLACEMENT OF THE DISHMACHINE; (24) REPLACEMENT WEAR ITEMS INCLUDING, BUT NOT LIMITED TO, CURTAINS, DRAIN BALLS, DOOR GUIDES, GASKETS, O-RINGS, SEALS, SQUEEZE TUBES, AND BEARINGS; (25) RESIDENTIAL USE; (26) USE WITH UTILITY SERVICE OTHER THAN THAT DESIGNATED ON THE RATING PLATE.

REVISION HISTORY

Revision	Date	Made by	Process	Details
A	7-18-16	JH	N/A	Initial release of the manual.
B	11-30-16	JH	N/A	Added LT and LT-H units.
C	12-13-16	JH	N/A	Updated Operating Parameters on pg. 3. Added Drain Quench Kit and P/N to pg. 52. Updated the Go Box kit, pg. 55.
D	3-6-17	JH	N/A	Updated pg. 42 with new motor and assembly P/Ns.
E	5-16-17	JH	8511	Updated water line connection information. Changed wording in the chemical feeder pump programming section to indicate changes are lost if closed without saving. Removed item #25 from pg. 47. Changed Discharge Hose to 05700-004-43-76 in the Wash Manifold Assembly. Added 05700-004-36-95 to HT Display page. Added Plumbing Options page.
F	6-6-17	JH	N/A	Corrected wash motor amps for LT/LT-H on Electrical Requirements page.
G	7-10-17	JH	N/A	Added 05940-002-78-97 to HT Control Panel page.
H	7-24-17	JH	N/A	Changed Heater Contactor Wires (HT Only) section to show current process.
J	8-23-17	JH	QOF-386	Replaced the middle 05975-003-35-21 with 05975-210-08-00 on the HT Control Panel page. Corrected items 4 and 5 on HT Chemical Feeder Pump Assembly page to 1/8" clear and added length. Added color and length to items 6 and 7 on HT Chemical Feeder Pump Assembly page. Added the 100" chemical tubes for red, white, and blue to LT/LT-H Chemical Feeder Pump Assembly page.
K	2-18-19	JH	8585 8599	Updated pg. 2. Corrected references to flow pressure on pg. 6. Updated references to E and F outputs on pgs. 9–10. Corrected P/Ns of motor assembly and motor only on pg. 42. Updated parts on pg. 44. Changed item #11 on pg. 48. Updated item #6 on pg. 52 and added link to instructions. Added links to instructions on pg. 53.
L	6-17-20	JH	8709 19-680	Revised Programming Chemical Feeder Pumps section. Updated chemical feeder pump assemblies. Updated plumbing for LT. Corrected drain hose P/N.
M	11-13-20	JH	N/A	Revised drain line size. Updated dimensional drawing.
N	6-15-21	JH	N/A	Updated amp values of LT-H. Changed P/N of high limit thermostat on LT-H Optional Heater Components page. Added LT-H float to Miscellaneous Parts page.
P	5-10-22	JH	22-1201 22-1202	Removed water hardness test strip. Updated Chemical Feeder Pumps section with black dot roller and corrected P/Ns and components. Added door magnet bracket to Door pages.
Q	12-7-22	JH	8901 22-1505	Changed chemical tubing. Updated peri-pumps to black components.
R	5-15-23	JH	8905	New control panel, digital controls, door, kick panel, plumbing, rinse tank, and schematic for HT.



DishStar® HT

Undercounter dishmachine; high-temperature, hot-water sanitizing, with a booster tank and detergent and rinse-aid chemical feeder pumps.

DishStar® LT

Undercounter dishmachine; low-temperature, chemical-sanitizing, with detergent, rinse-aid, and sanitizer chemical feeder pumps.

DishStar® LT-H

Undercounter dishmachine; low-temperature with wash tank heater, chemical-sanitizing, with detergent, rinse-aid, and sanitizer chemical feeder pumps.

The manufacturer provides technical support for all of the machines detailed in this manual. We strongly recommend that you refer to this manual before making a call to our technical support staff. Please have this manual open when you call so that our staff can refer you, if necessary, to the proper page. Technical support is not available on holidays.

Contact technical support toll free at 1-888-800-5672.

Technical support is available for service personnel only.

TABLE OF CONTENTS

GUIDES

Symbols.....	1
Abbreviations & Acronyms	1

SPECIFICATIONS

Machine Dimensions	2
Operating Parameters	3
Electrical Requirements	4

INSTALLATION

Installation Instructions.....	5
<i>Inspection</i>	5
<i>Unpacking</i>	5
<i>Plumbing</i>	5
<i>Water Supply Connections</i>	5
<i>Pressure Regulator</i>	6
<i>Shock Absorber</i>	6
<i>Connecting the Drain Line</i>	6
<i>Plumbing Check</i>	6
<i>Electrical Power Connections</i>	7
<i>Voltage Check</i>	7
<i>Surrounding Area</i>	7
<i>Thermostats</i>	7
<i>Chemical Feeder Equipment</i>	8
<i>Preparing Chemical Feeder Pumps</i>	8
<i>Priming Chemical Feeder Pumps</i>	8
<i>Programming Chemical Feeder Pumps (LT/LT-H)</i>	9
<i>Leveling</i>	12
<i>Initial Fill (HT Only)</i>	12

OPERATION

Operating Instructions	13
<i>Preparation</i>	13
<i>Filling the Wash Tub</i>	13
<i>Ware Preparation</i>	14
<i>Washing a Rack of Ware</i>	14
<i>Operational Inspection</i>	14
<i>Shutdown & Cleaning</i>	15
<i>Deliming HT</i>	17
<i>Deliming LT/LT-H</i>	18
<i>Detergent Control</i>	19

TABLE OF CONTENTS

MAINTENANCE

Preventative Maintenance.....	20
-------------------------------	----

TROUBLESHOOTING

HT Setpoints.....	21
HT Fault Codes	25
Troubleshooting.....	28

PARTS

HT Control Panel.....	30
LT Control Panel.....	32
LT-H Control Panel	33
HT Display Panel.....	34
LT Display Panel.....	35
LT-H Display Panel.....	36
Terminal Block Box.....	37
HT Chemical Feeder Pumps	38
LT/LT-H Chemical Feeder Pump Assembly.....	39
LT/LT-H Chemical Feeder Pumps	40
HT Plumbing.....	41
LT/LT-H Plumbing	43
Plumbing Options	45
Vacuum Breaker	46
Wash Manifold.....	47
Motor & Pump	49
Rinse Arms & Wash Arms	51
HT Rinse Tank.....	53
HT Door.....	54
LT/LT-H Door	56
Miscellaneous Door Components	58
Frame & Panel Components	60
Miscellaneous Parts	62
Stands & Components	63
LT-H Optional Heater Components	64
LT/LT-H Vacuum Switch	65
LT/LT-H Vacuum Switch Install	66

SCHEMATICS

DishStar HT 208-240 V, 50/60 Hz, 1/3 Phase.....	67
DishStar LT/LT-H 115 V, 50/60 Hz, 1 Phase	68

SYMBOLS



- Risk of Injury to Personnel



- Risk of Damage to Equipment



- Risk of Electrical Shock



- Caustic Chemicals



- Reference Data Plate



- Lockout Electrical Power

NOTICE - Important Note



- Instructions Hyperlink

ABBREVIATIONS & ACRONYMS

ANSI - American National Standards Institute

Btu/Hr - British Thermal Units per Hour

CFM - Cubic Feet per Minute

GHT - Garden Hose Thread

GPH - Gallons per Hour

GPM - Gallons per Minute

GPG - Grains per Gallon

HP - Horsepower

Hz - Hertz

ID - Inside Diameter

kW - Kilowatts

MCA - Minimum Circuit Ampacity

MOP - Maximum Overcurrent Protection

NFPA - National Fire Protection Association

NPT - National Pipe Thread

OD - Outside Diameter

PRV - Pressure Regulating Valve

PSI - Pounds per Square Inch

V - Volts

SPECIFICATIONS

MACHINE DIMENSIONS

LEGEND

A - Electrical Connection

C - Drain Hose

(1" ID, install into 1 1/2" MIN Drain with Air-gap)

B - Water Inlet (with 6' Hose)
(3/4" Male GHT, connect to true
1/2" ID line, MIN 110 °F)

All dimensions from the floor can be increased 1"
using the machine's adjustable feet.

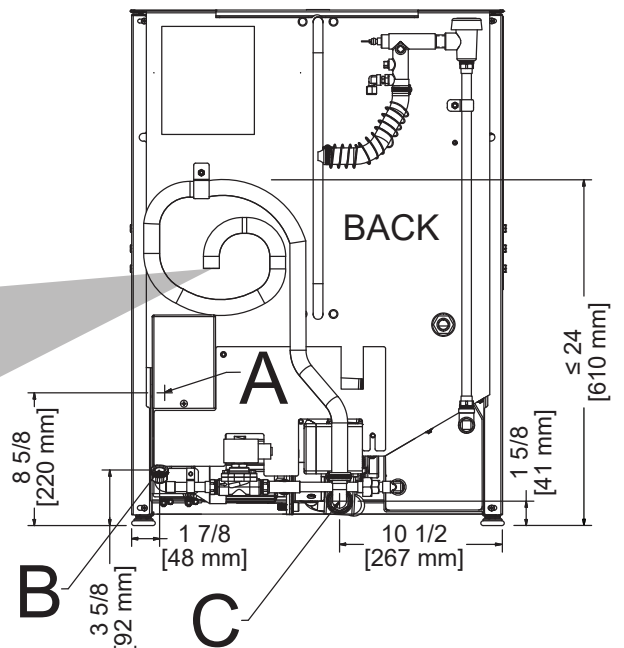
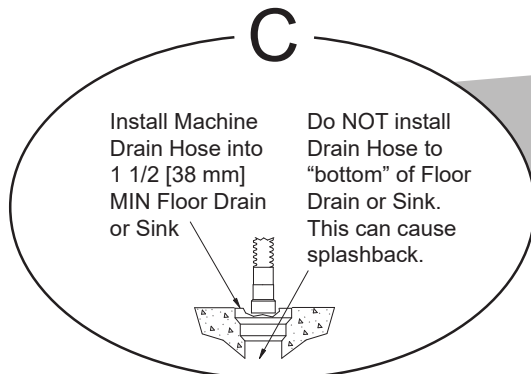
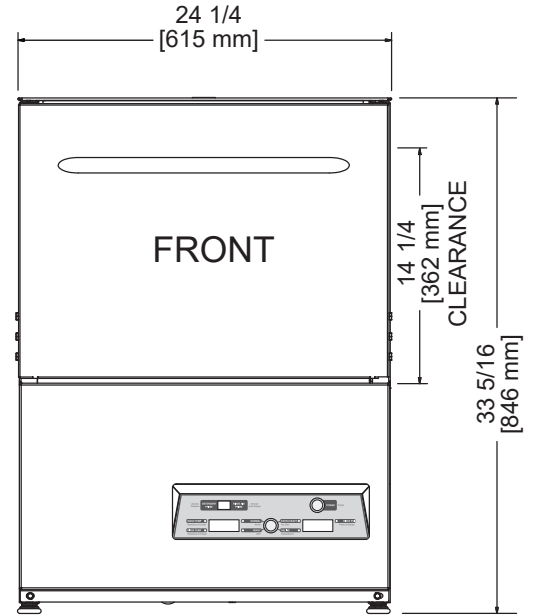
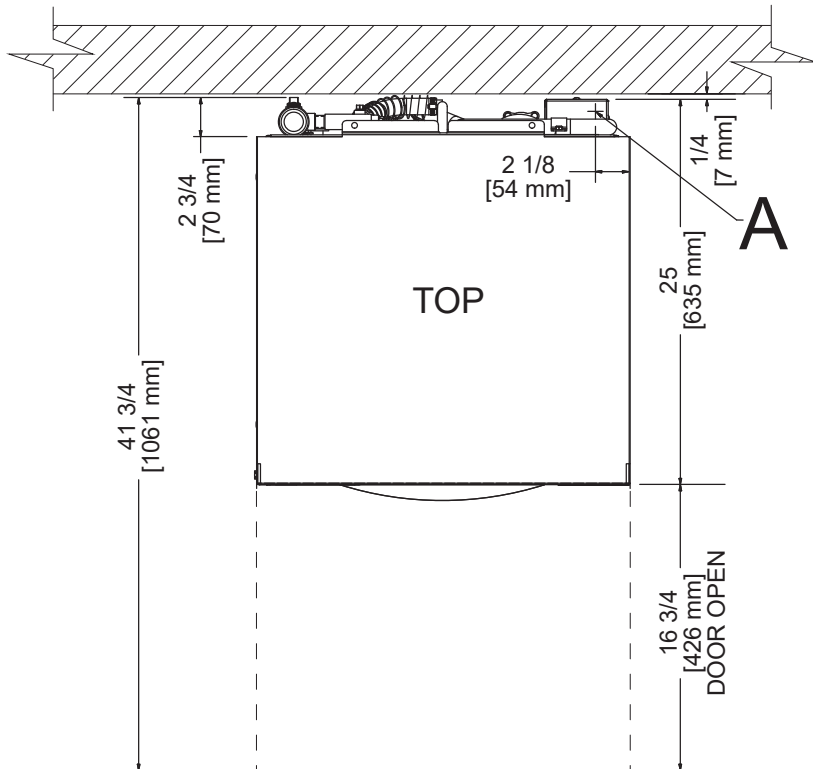

NOTICE HT shown.

Operating Capacity:	HT	LT/LT-H
Racks per Hour	24	24
Dishes per Hour	600	600
Glasses per Hour	864	864
Gallons per Rack	1.1	1.2
Gallons per Hour	26.4	28.8

Tank Capacity (Gallons):

Wash Tank	1.1	1.2
Rinse Tank	3.0	N/A

Electrical Loads (as applicable):

Wash Motor HP	1.0	1.0
Rinse Heater kW	6.7 (208 V)/8.2 (230 V)	N/A
Wash Heater kW	N/A	1.5



NOTICE

Always refer to the machine data plate for specific electrical and water requirements. The material provided on this page is for reference only and is subject to change without notice.

HOT WATER SANITIZING

Water Temperatures (°F):

Minimum Wash Temperature	150	N/A
Minimum Rinse Temperature	180	N/A
Minimum Incoming Water Temperature	110	N/A

CHEMICAL SANITIZING

Water Temperatures (°F):

Minimum Wash Temperature	N/A	120
Minimum Rinse Temperature	N/A	120
Minimum Incoming Water Temperature	N/A	120

Other Water Requirements:

Water Flow Pressure (PSI)	20 ± 5	20 ± 5
Flow Rate Minimum (GPM)	6.6	6.6
Water Line Connection Size (NPT)	3/4" GHT	3/4" GHT
Water Line Size (NPT)	1/2"	1/2"
Drain Line Size (NPT)	1" ID	1" ID

NOTICE *Install drain line into MIN 1 1/2" Drain with Air-gap.*

Minimum Chlorine Required (PPM)	N/A	50
---------------------------------	-----	----

NOTICE



All electrical ratings provided in this manual are for reference only. Always refer to the machine data plate to get exact electrical information for this machine. **All electrical work performed on machines should be done in accordance with applicable local, state, territorial, and national codes.** Work should only be performed by qualified electricians and authorized service agents.

The electrical configurations of the DishStar series of machines are as follows:

Available Electrical Characteristics:

HT

- 208 V, 60 Hz, Single-phase
- 230 V, 60 Hz, Single-phase

LT/LT-H

- 115 V, 60 Hz, Single-phase

Available Wash Tank Heater:

- 1.5 kW (LT-H Only)

**Motor and heater do not operate at same time. Total load based on motor load.*

**Electrical Characteristics
DishStar HT**

VOLTS	208	230
PHASE	1	1
FREQ	60	60
WASH MOTOR AMPS	5.0 A	5.0 A
RINSE HEATER AMPS	32.2 A	35.7 A
TOTAL LOAD	37.2 A	40.7 A

DishStar LT

VOLTS	115
PHASE	1
FREQ	60
WASH MOTOR AMPS	10.0 A
TOTAL LOAD	10.0 A

DishStar LT-H

VOLTS	115
PHASE	1
FREQ	60
WASH MOTOR AMPS	10.0 A
WASH HEATER AMPS	13.0 A
TOTAL LOAD	10.0 A*

INSPECTION

Do not throw away container if damage is evident!

Before installing the unit, check packaging and machine for damage. Damaged packaging might be an indication of damage to the machine. If there is any type of damage to both packaging and unit, do not throw away the packaging. The dishmachine has been inspected at the factory before shipping and is expected to arrive in new, undamaged condition. However, rough handling by carriers or others might result in damage to the unit while in transit. If this occurs, do not return the unit to the manufacturer. Instead, contact the carrier and ask them to send a representative to the site to inspect the damage and request that an inspection report be completed.

Contact the carrier within 48 hours of receiving the machine as well as the dealer that sold you the unit.

UNPACKING

Remove the box and machine from the pallet before installing. Open the front door and remove all of the materials from inside. Once unpacked, verify there are no missing parts (reference the Parts section). If a part is missing, contact the manufacturer immediately.

PLUMBING

The plumber must flush the incoming water line!

All plumbing connections must be made to adhere to local, state, territorial, and national codes. The installing plumber is responsible for ensuring the incoming water lines are flushed of debris before connecting to the machine. Note that chips and materials from cutting processes can become lodged in the solenoid valves and prevent them from opening or closing. Any valves that are found to be fouled or defective because of foreign matter left in the water line, and any subsequent damage, are not the responsibility of the manufacturer.

A water hardness test must be performed.

A water hardness test must be performed. A hardness test kit can be found on the warning tag that is attached to the incoming plumbing connection on the back of the machine. If water hardness is higher than 3 GPG, install a water softener or install the optional Scale Prevention System (SPS). See the Plumbing Options page and the next section for more information on the SPS.

See the Machine Dimensions page and reference item "B" for water inlet connection location.

NOTICE *The manufacturer does NOT endorse "Tankless On-demand" water heaters for use with their dishmachines. The manufacturer DOES endorse, and highly recommends, the standard "Tank" style water heaters, sized to properly handle the water heating requirements of the facility.*

**WATER SUPPLY CONNECTIONS:
WATER HARDNESS HIGHER THAN 3 GPG**

A water hardness test must be performed. If water hardness is higher than 3 GPG and a water softener is not being used, install an SPS (see Plumbing Options page) into the water line between the facility water line and the machine water line (installed at the factory). Observe proper inlet/outlet water directions. A water shut-off valve should be installed before installing the SPS to allow access for service. The water supply must be capable of a minimum of 20 ± 5 PSI “flow” pressure at the recommended temperature indicated on the data plate.

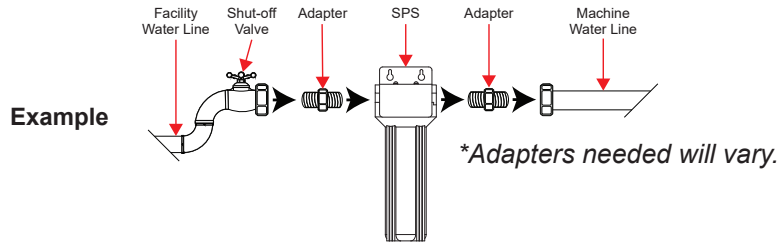

**WATER SUPPLY CONNECTIONS:
WATER HARDNESS LOWER THAN 3 GPG**

If water hardness tests at 3 GPG or lower, connect the machine water line (installed at the factory) to the facility water line. A water shut-off valve should be installed in the water line between the facility supply and the machine to allow access for service. The water supply line must be capable of a minimum of 20 ± 5 PSI “flow” pressure at the recommended temperature indicated on the data plate.

PRESSURE REGULATOR

The manufacturer has an optional water pressure regulator to accommodate areas where water pressure fluctuates or is higher than the recommended pressure. Take care not to confuse static pressure with flow pressure: static pressure is line pressure in a “no flow” condition (all valves and services are closed); flow pressure is the pressure in the fill line when the valve is opened during the cycle. See the Plumbing Options page.

Take care not to confuse static pressure with flow pressure!

SHOCK ABSORBER

It is suggested that a shock absorber (not supplied) be installed on the incoming water line. This prevents water hammer (hydraulic shock)—induced by the solenoid valve as it operates—from causing damage to the equipment. See the Plumbing Options page.

CONNECTING THE DRAIN LINE

The dishmachine has a pumped (pressure) drain capable of pumping waste water to a height of 24” above the floor to the kitchen’s drain system. Each dishmachine is supplied with a drain hose. When installed, it will extend from the rear side of the machine. There must be an air-gap between the machine drain line and the floor sink or drain. If a grease trap is required by code, it should have a flow capacity of 12 GPM.

PLUMBING CHECK

After installing the incoming fill line and the drain line, slowly turn on the water supply to the machine. Check for any leaks and repair as required. All leaks must be repaired before operating the machine.

ELECTRICAL POWER CONNECTIONS



Disconnect electrical power at the breaker or disconnect switch and tag-out in accordance with procedures and codes.

Electrical and grounding conductors must comply with the applicable portions of the National Electric Code ANSI/NFPA 70 (latest edition) and/or other electrical codes.

The data plate is located at the left-front side of the dishmachine. Refer to the data plate for machine operating requirements, machine voltage, total amperage, and serial number.

Remove the back panel and set aside. This will require removing the screw at the bottom of the back panel with a phillips screwdriver. Install 3/4" conduit into the pre-punched holes in the back of the control box. Route power wires and connect to power block and grounding lug. Install the service wires (L1 and L2 for HT, L1 and N for LT/LT-H) to the appropriate terminals as they are marked on the terminal block. Install the grounding wire into the lug provided. It is recommended that "DE-OX" or another similar anti-oxidation agent be used on all power connections.

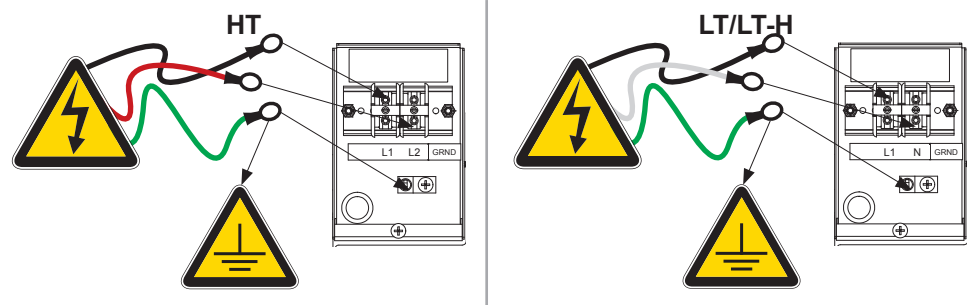

VOLTAGE CHECK



Ensure the ON/OFF switch is in the OFF position and apply power to dishmachine. Check the incoming power at the terminal block and ensure it corresponds with the voltage listed on the data plate. If not, contact a qualified service agency to examine the problem. Do not run dishmachine if voltage is too high or too low. Shut-off the service breaker and advise all proper personnel of the location of the breaker and any problems. Replace the control box cover and tighten-down the screws.

SURROUNDING AREA

This is a commercial dishmachine and reaches temperatures that can exceed those generated by a residential machine. Surrounding countertops, cabinets, flooring material, and subfloor material must be designed and/or selected with these higher temperatures in mind.

NOTICE Any damage to surrounding area that is caused by heat and/or moisture to materials that are not recommended for higher temperatures will not be covered under warranty or by the manufacturer.

THERMOSTATS

The thermostats on this dishmachine have been set at the factory. They should only be adjusted by an authorized service agent.

CHEMICAL FEEDER EQUIPMENT



CAUTION! Chlorine-based sanitizers can be detrimental to this machine if the chemical solution is too strong. See a chemical professional to ensure the dispenser is set-up correctly.

The bottom of the chemical container cannot be located any higher than 8" from the floor. If the unit is equipped with the 6" or 18" table stand, the highest position will be 14" or 26" from the floor, respectively. It is important to remember that if you decide to operate the unit in chemical-sanitizing mode, you must ensure an appropriate chlorine-based sanitizer is used in the final rinse line.

PREPARING CHEMICAL FEEDER PUMPS

The DishStar HT dishmachine is supplied with detergent and rinse-aid chemical feeder pumps.

The DishStar LT and LT-H dishmachines are supplied with detergent, rinse-aid, and sanitizer chemical feeder pumps.

Locate the open ends of the chemical tubes with the tube stiffeners and place each one in the appropriate container.

- Red Tubing = Detergent
- Blue Tubing = Rinse-Aid
- White Tubing = Sanitizer

PRIMING CHEMICAL FEEDER PUMPS

Chemical feeder pumps need priming when the machine is first installed or if the chemical lines have been removed and air was allowed to enter.



CAUTION! Water must be in the sump and wash tank before chemicals are dispensed.

HT

1. Press and hold prime button toward DETERGENT PRIME until display shows timer. Priming cycle defaults to 70 seconds. Observe wash tank during priming cycle. If too much detergent, press prime button to stop priming cycle. If not enough, run priming cycle again.

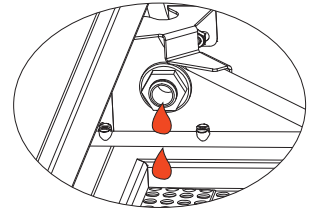

2. Press and hold prime button toward RINSE AID PRIME until display shows timer. Priming cycle defaults to 180 seconds.

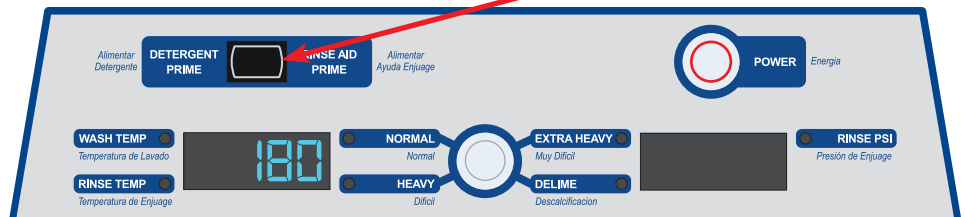

WARNING! Some of the chemicals used in dishwashing might cause chemical burns if they come in contact with skin. Wear protective gear when handling these chemicals. If any contact with skin occurs, immediately follow the treatment instructions provided with the chemicals.

PRIMING CHEMICAL FEEDER PUMPS

- The amount of detergent might need adjustment depending on water quality and type of detergent. The amount of rinse-aid might need adjustment depending on water hardness and results. Refer to HT Setpoints section for instructions on adjusting amount of chemicals being dispensed.

LT/LT-H

- Hold each prime switch (Detergent, Rinse-aid, and Sanitizer) until the respective chemical can be seen entering the wash tank.

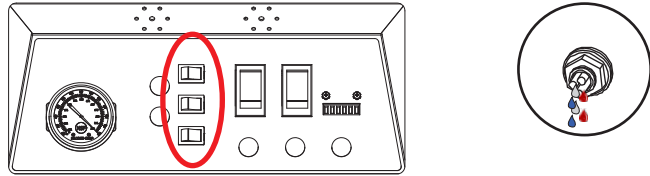

- Detergent is dispensed as required during the wash cycle by the timer. The amount of detergent might need to be increased or decreased depending upon water quality and type of detergent.
- Rinse-aid is dispensed as required into the final rinse. The amount of rinse-aid might need to be adjusted depending upon water hardness and results.
- Sanitizer is dispensed proportionally into the final rinse water line. The amount of sanitizer might need to be adjusted depending on concentration.
- See Programming Chemical Feeder Pumps (LT/LT-H) section to adjust chemical amounts using the universal timer.

PROGRAMMING CHEMICAL FEEDER PUMPS (LT/LT-H)

To access programming mode, machine must be ON and between cycles.
The PROGRAM (PGM) light will be flashing.

- Locate universal timer. On the timer, locate programming board and programming buttons.

LT/LT-H DIP-switch Settings
(0 = On, X = Off)

X		X	X	X					
0	0							0	0
8	7	6	5	4	3	2	1		

ON ↓

Universal timer is located on control panel. Use Parts section of this manual for reference.

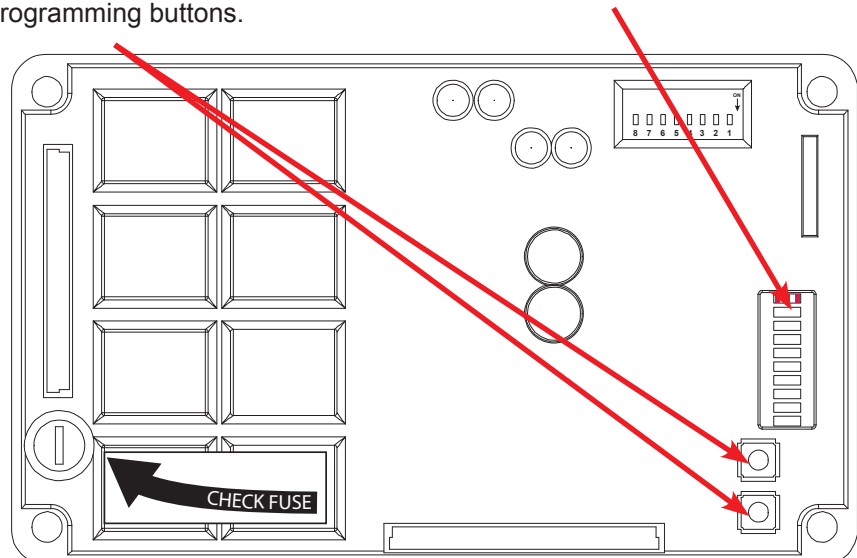

PROGRAMMING CHEMICAL FEEDER PUMPS (LT/LT-H)

- Programming board and buttons are not labeled on the timer. Use the graphic below for reference.

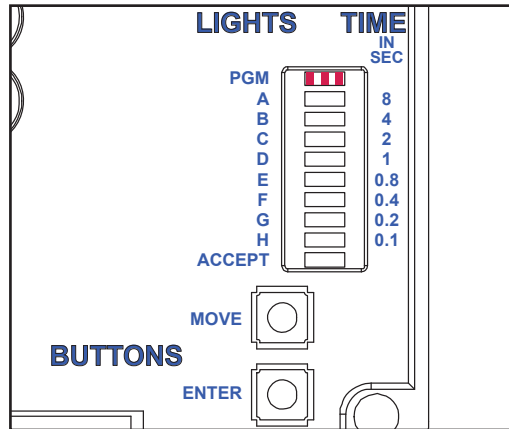

- Press and hold both the MOVE and ENTER buttons simultaneously for two seconds then release. PGM light will go steady and light A will start flashing.

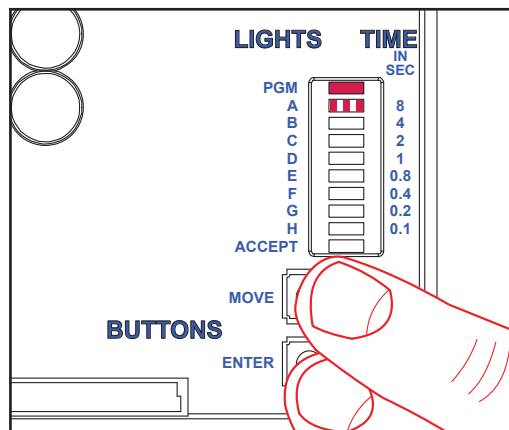

= Light Steady
 = Light Flashing

- Press MOVE button to move the flashing light to E, F, G, or H. Options A–D are not adjustable.

PGM	DishStar LT/LT-H
E	Rinse-aid
F	Fill
G	Sanitizer
H	Detergent

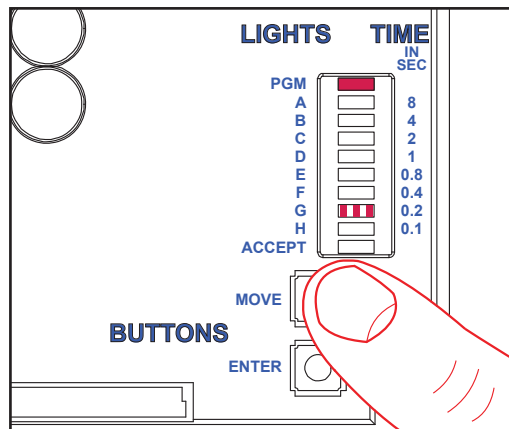

Example here shows option G (sanitizer) being selected.

PROGRAMMING CHEMICAL FEEDER PUMPS (LT/LT-H)

 = Light Steady
 = Light Flashing

- Press ENTER button. PGM light will stay steady, lights for the current time setting will come on, and ACCEPT light will start flashing.

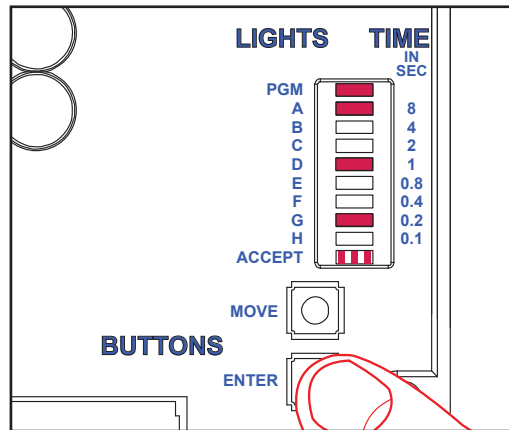

Example here shows current setting for G at 9.2 seconds (each selected time option is added to get the total).

- Press MOVE button to cycle through the different time options. To choose a time option, press ENTER while the light is flashing on that option. To deselect the option, press ENTER again.



CAUTION! Light for each desired option must be steady before moving on.

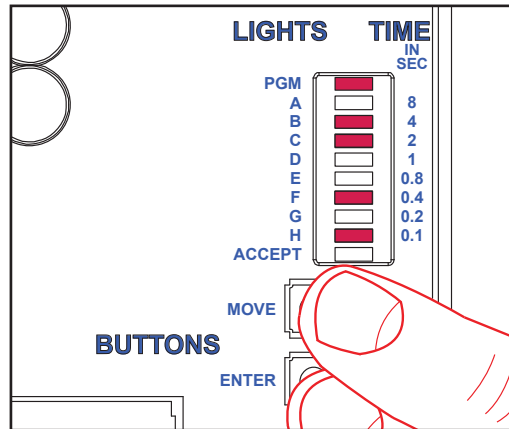

Example here shows setting for G changed to 6.5 seconds (each selected time option is added to get the total).

- Once all desired time options are selected, press MOVE button until ACCEPT light is flashing (lights for selected time options should still be steady).

 = Light Steady
 = Light Flashing

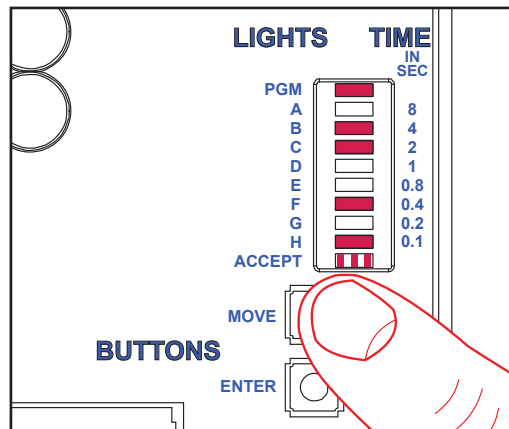

**PROGRAMMING
CHEMICAL FEEDER
PUMPS (LT/LT-H)**

- Press ENTER button. This saves the changed parameters and exits the programming mode. PGM light will go from steady to flashing.

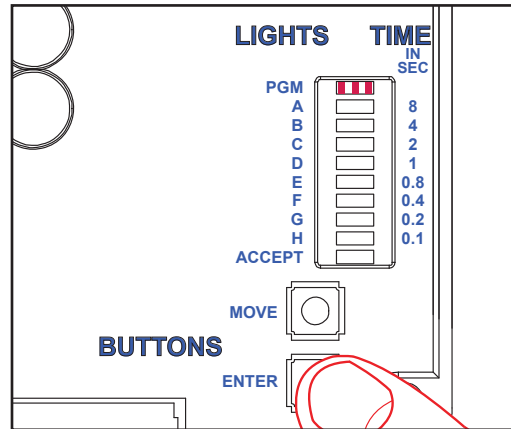

- To change any other values, repeat the process above. To revert back to a previous setting, repeat the process above and change parameters back to previous settings.

In programming mode, if there have been no keypad inputs for approximately two minutes, the system will automatically exit out of programming mode. Any changes to parameters will be lost when programming mode is automatically exited.

LEVELING

The dishmachine is designed to operate while level. This is important to prevent any damage to the machine during operation and to ensure the best possible results. The unit comes equipped with adjustable bullet feet which can be turned using a pair of pliers. Since this machine is an undercounter unit, it should be leveled as close as possible to the unit's location before it is pushed under the counter.

**INITIAL FILL
(HT ONLY)**

- Press POWER button and listen for machine to stop filling.
- Press POWER button and listen for machine to stop draining.
- Repeat Steps 1 and 2.
- Press POWER button and listen for machine to stop filling.
- Machine is now ready for operation.

HT models with serial numbers before 23D415452 have different initial fill instructions. Click here to open earlier manual.

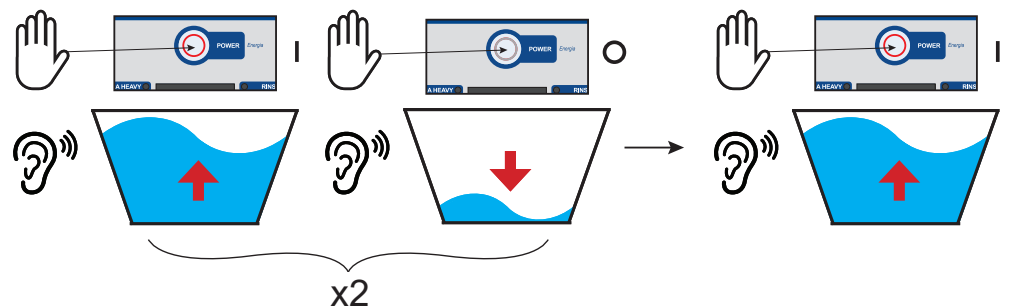

PREPARATION Before operating machine, verify:

1. Strainer is in place and clean.

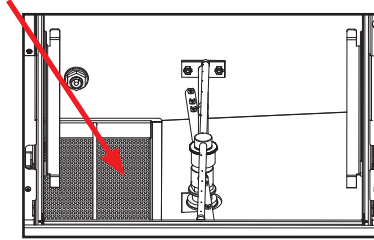

2. Wash and rinse arms are screwed securely into place and end-caps are tight.

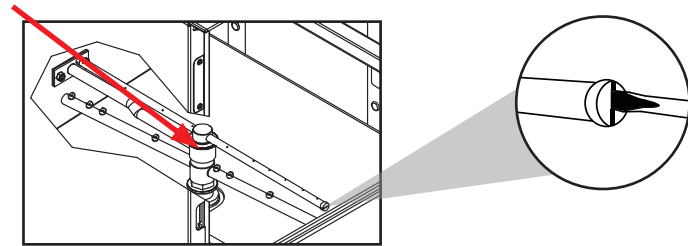

3. Wash and rinse arms rotate freely.

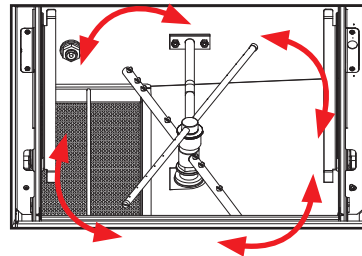

4. Chemical levels in chemical containers are correct.

LT and LT-H have combined wash/rinse arms.

FILLING THE WASH TUB

1. Close door.
2. Turn machine on.

See Initial Fill section for HT models.

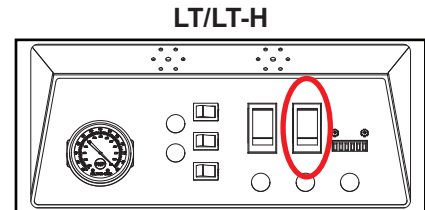
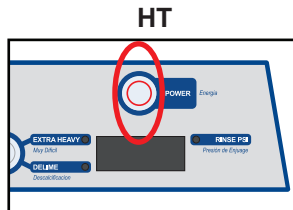

3. Machine will automatically begin to fill.
4. Once wash tub is filled, wait until wash temperature is at least 150 °F for HT and 120 °F for LT/LT-H before operating machine.

WARE PREPARATION

Properly preparing ware will help ensure good results and fewer re-washes. If not done properly, ware might not come out clean and the efficiency of the machine will be reduced. Putting unscrapped dishes into the machine affects its performance, so always remove scraps from ware before loading into a rack. Pre-rinsing and pre-soaking are good ideas, especially for silverware and casserole dishes.

Place cups and glasses upside-down in racks so they don't hold water during the cycle. The dishmachine sanitizes as well as cleans. To do this, ware must be properly prepared before being placed in the machine.

WASHING A RACK HT OF WARE

1. Ensure machine is on and at operating temperature.
2. Open door and load rack.
3. Push START button.

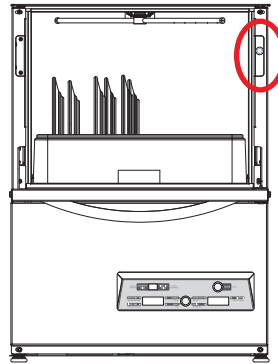

4. LED will turn green. Operator has three seconds to close door before LED goes out and START button must be pressed again.

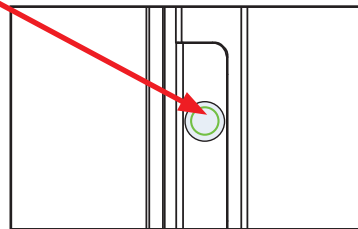

5. Cycle automatically starts when door is closed.

LT/LT-H

1. Ensure machine is on and at operating temperature.
2. Open door and load rack.
3. Close door and ensure WASH/DELIME switch is on WASH.
4. Push START button. Cycle light comes on and cycle automatically starts.

OPERATIONAL INSPECTION

Based on use, the strainer might become clogged with soil and debris as the workday progresses. Operators should regularly inspect the strainer to ensure it has not become clogged. If clogged, it will reduce the washing capability of the machine. Instruct operators to clean out the strainer at regular intervals or as required by workload.

SHUTDOWN & CLEANING

1. At end of workday, close door. **HT**: Press POWER button. **LT/LT-H**: Flip ON/OFF switch to OFF position.

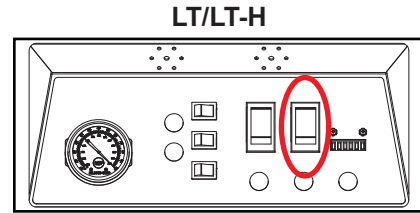
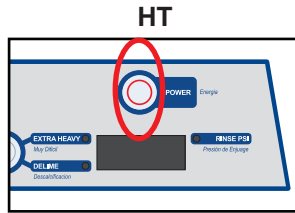

2. Drain pump will activate and empty machine of water.

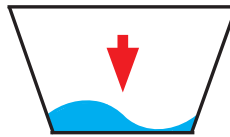

3. When draining stops, remove strainer.

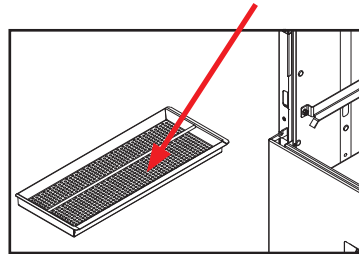

4. Remove soil and debris from strainer and set aside.

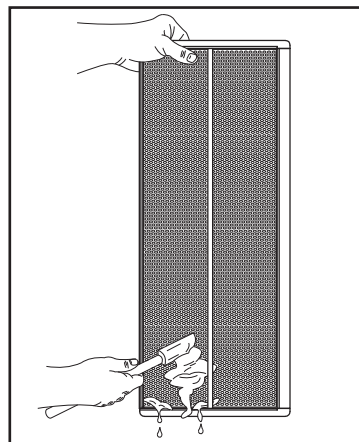

5. Unscrew wash and rinse arms manifolds. Remove end-caps and flush arms with water. Use a brush to clean inside of the arms. If nozzles appear to be clogged, use a toothpick to remove debris.

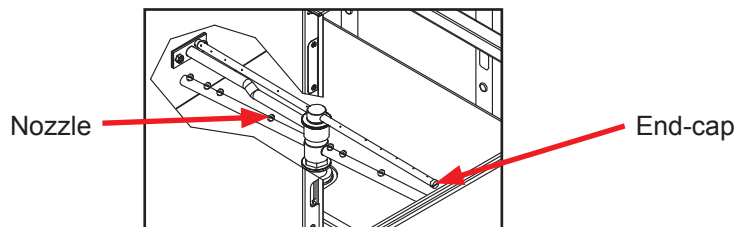

CAUTION! Do NOT beat strainers to remove soil and debris!

LT and LT-H have combined wash/rinse arms.

SHUTDOWN & CLEANING

6. Wipe inside of machine out, removing all soil and scraps.

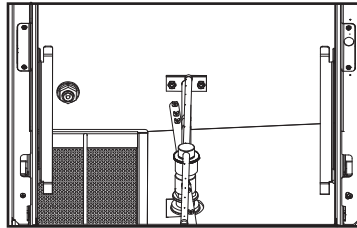

7. Reassemble wash and rinse arms.

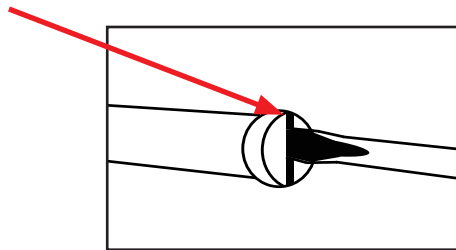

8. Replace wash and rinse arms. The arms only need to be hand-tight, do not use tools to tighten them down.

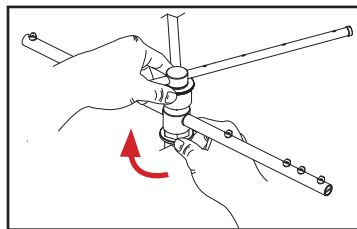

9. Reinstall strainer and close door.

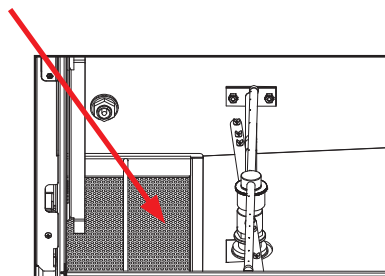

LT and LT-H have combined wash/rinse arms.

DELMING HT

If machine is equipped with an SPS and lime is becoming a frequent problem, the cartridge needs to be replaced. To order a replacement cartridge, call the manufacturer.

1. Remove rinse arms and place in sink with deliming solution (leave for amount of time recommended by chemical supplier).

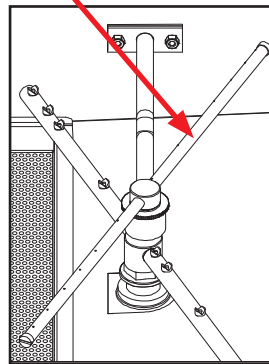

2. Replace rinse arms.
3. If the machine is full of water, close door, press power button, and allow the machine to drain and shut-off.
4. Follow Filling the Wash Tub section of this manual.
5. Open door and add amount of deliming solution recommended by chemical supplier.
6. Use cycle button to select Delime.

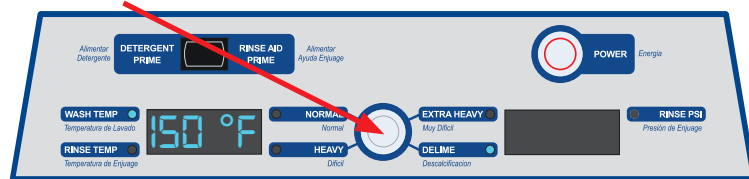

7. Close door and the machine will begin delime cycle. Cycle timer shows on right display. LED on power button will turn green.

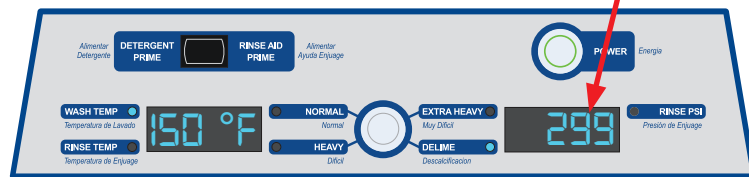

8. The machine will delime, drain, and refill. When cycle is complete right display will turn off.
9. Wait five minutes and inspect the machine. If the machine is not delimed, run again.
10. When clean, use cycle button to select Normal.

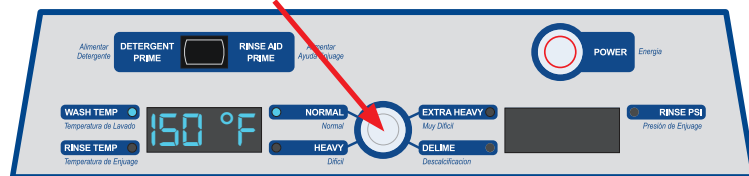

11. Run two Normal cycles to remove residual deliming solution.
12. The machine is now ready for normal operation.

**DELIMING
LT/LT-H**

If machine is equipped with an SPS and lime is becoming a frequent problem, the cartridge needs to be replaced. To order a replacement cartridge, call the manufacturer.

1. Flip ON/OFF switch to ON position.

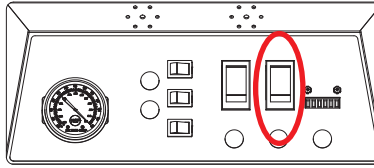

2. Flip WASH/DELIME switch to DELIME position.

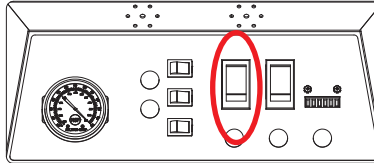

3. Add deliming solution per chemical supplier's instructions.
4. Close door.
5. Push START button.

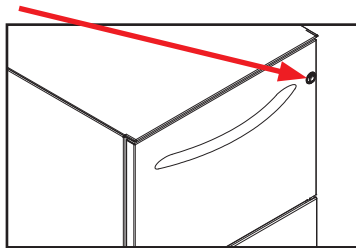

6. Wait until cycle is complete and inspect inside of machine. If machine is not delimed, run again.

NOTICE *HT and LT/LT-H: This equipment is not recommended for use with deionized water or other aggressive fluids. Use of deionized water or other aggressive fluids will result in corrosion and failure of materials and components. Use of deionized water or other aggressive fluids will void the manufacturer's warranty.*

DETERGENT CONTROL

Detergent usage and water hardness are two factors that greatly contribute to the machine's operating efficiency. Using the proper amount of detergent can become a source of substantial savings. A qualified water-treatment specialist can determine what is needed for maximum efficiency from the detergent.

- Hard water greatly affects the performance of the machine, causing the amount of detergent required for washing to increase. If the machine is installed in an area with hard water, the manufacturer recommends the installation of water treatment equipment.
- Deposited solids from hard water can cause spotting that will not be removed with a drying agent. Treated water will reduce this occurrence.
- Treated water might not be suitable for use in other areas of operation and it might be necessary to install a water treatment system for the water going to the machine only. Discuss this option with a qualified water treatment specialist.
- Properly train operators on how much detergent is to be used per cycle. Meet with a water treatment specialist and chemical supplier to discuss a complete training program for operators.
- Water temperature is an important factor in ensuring the machine functions properly, and the machine's data plate details what the minimum temperatures must be for the incoming water supply, the wash tank, and the rinse tank. If minimum requirements are not met, it's possible that dishes will not be clean or sanitized.
- Instruct operators to observe the required temperatures and to report when they fall below the minimum allowed. A loss of temperature can indicate a larger problem.



PREVENTATIVE MAINTENANCE

The manufacturer highly recommends that only qualified service personnel perform any maintenance and repairs not specifically discussed in this manual.



WARNING! *Unqualified personnel performing maintenance on the machine may void the warranty, lead to larger problems, or cause harm to the operator.*

By following the operating and cleaning instructions in this manual, you should get the most efficient results from your machine. As a reminder, here are some steps to take to ensure that you are using the dishmachine the way it was designed to work:



CAUTION!

Do NOT beat strainers to remove debris!

1. Ensure the water temperatures match those listed on the machine data plate. There can be a variety of reasons why your water temperature could be too low.
2. Ensure all strainers are clean and securely in place before operating the machine. When cleaning out strainers, do NOT beat them on waste cans. Wipe out strainers with a rag and rinse under a faucet if necessary. Use a toothpick to dislodge any stubborn debris.
3. Ensure all wash and rinse arms are secure in the machine before operating.
4. Remove as much soil from dishes by hand as possible before loading into racks.
5. Do not overfill racks.
6. Ensure glasses are placed upside-down in the rack.
7. Ensure all chemicals being injected into machine have been verified at the correct concentrations.
8. Clean out the machine at the end of every workday per the Shutdown and Cleaning section of this manual.
9. Follow all safety procedures, whether listed in this manual or put forth by local, state, or national codes/regulations.

RINSE TEMP

To access Setpoints, the machine must be on and not in cycle.

1. Push and hold cycle button a minimum of six seconds. Temperature shows on left display and will flash on and off.



2. Once button is released, press prime button (left rocker to increase and right rocker to decrease). This changes rinse temp one degree at a time to a maximum of 192 °F or a minimum of 180 °F.



3. Once desired temperature is selected, press and hold cycle button a minimum of three seconds and no more than five seconds (after three seconds temperature will stop flashing). Release cycle button to accept and move to next setpoint (drain time).



Adjustable Setpoints:
 Rinse Temp
 Drain Time
 Detergent Time
 Rinse-aid Time
 Detergent Priming Time
 Rinse-aid Priming Time
 Temperature Scale

DRAIN TIME

1. Once setting changes to drain time, current setting shows on left display and will flash on and off.



2. Press prime button (left rocker to increase and right rocker to decrease). This changes drain time one second at a time.

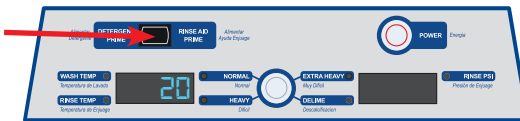

3. Once desired time is selected, press and hold cycle button a minimum of three seconds and no more than five seconds (after three seconds time will stop flashing). Release cycle button to accept and move to next setpoint (detergent time).



If there is no activity (button presses) for 30 seconds, display will exit Setpoints mode without saving changes.

To exit Setpoints at any time, hold cycle button a minimum of six seconds. Display will stop flashing and return to wash temperature. Machine is ready to operate.

DETERGENT TIME

If there is no activity (button presses) for 30 seconds, display will exit Setpoints mode without saving changes.

1. Once setting changes to detergent time, current setting will flash on and off.

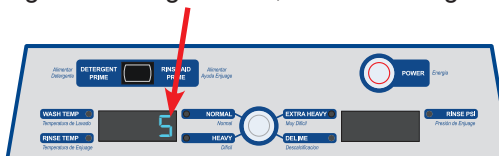

2. Press prime button (left rocker to increase and right rocker to decrease). This changes detergent time one second at a time.

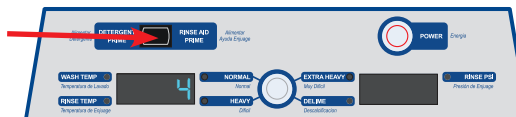

3. Once desired time is selected, press and hold cycle button a minimum of three seconds and no more than five seconds (after three seconds time will stop flashing). Release cycle button to accept and move to next setpoint (rinse-aid time).



RINSE-AID TIME

To exit Setpoints at any time, hold cycle button a minimum of six seconds. Display will stop flashing and return to wash temperature. Machine is ready to operate.

1. Once setting changes to rinse-aid time, current setting will flash on and off.



2. Press prime button (left rocker to increase and right rocker to decrease). This changes rinse-aid time one second at a time.



3. Once desired time is selected, press and hold cycle button a minimum of three seconds and no more than five seconds (after three seconds time will stop flashing). Release cycle button to accept and move to next setpoint (detergent priming time).



DETERGENT PRIMING TIME

If there is no activity (button presses) for 30 seconds, display will exit Setpoints mode without saving changes.

1. Once setting changes to detergent priming time, current setting will flash on and off.



2. Press prime button (left rocker to increase and right rocker to decrease). This changes detergent priming time one second at a time.



3. Once desired time is selected, press and hold cycle button a minimum of three seconds and no more than five seconds (after three seconds time will stop flashing). Release cycle button to accept and move to next setpoint (rinse-aid priming time).



RINSE-AID PRIMING TIME

To exit Setpoints at any time, hold cycle button a minimum of six seconds. Display will stop flashing and return to wash temperature. Machine is ready to operate.

1. Once setting changes to rinse-aid priming time, current setting will flash on and off.



2. Press prime button (left rocker to increase and right rocker to decrease). This changes rinse-aid priming time one second at a time.



3. Once desired time is selected, press and hold cycle button a minimum of three seconds and no more than five seconds (after three seconds time will stop flashing). Release cycle button to accept and move to next setpoint (energy saver on/off).



TEMPERATURE SCALE

If there is no activity (button presses) for 30 seconds, display will exit Setpoints mode without saving changes.

To exit Setpoints at any time, hold cycle button a minimum of six seconds. Display will stop flashing and return to wash temperature. Machine is ready to operate.

1. Once setting changes to temperature scale, °F or °C will flash on and off.

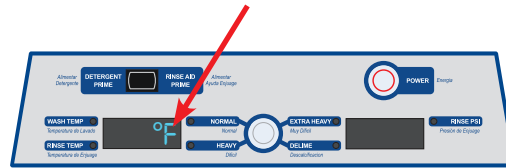

2. Press prime button to switch to other setting.



3. Once desired scale is selected, press and hold cycle button a minimum of three seconds and no more than five seconds (after three seconds scale will stop flashing). Release cycle button to accept and move to next setpoint (back to wash temp).

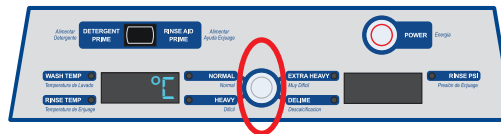

DISPLAY SHOWS	POSSIBLE CAUSES	REMEDY
"F1 Service needed," "No water in Booster"	<ol style="list-style-type: none"> 1. Low or no water pressure. 2. Faulty inlet valve or fill relay. 3. Contactor to booster heater not turning off. 4. Faulty temperature input (P12) on IO module. 5. Faulty temperature probe (T3). 6. Faulty float switch allows heaters to operate with no water in tub. 	<ol style="list-style-type: none"> 1. Verify incoming water pressure is 10 ± 2 PSI. 2. Verify that fill relay is supplying voltage to fill solenoid. Replace faulty component. 3. Check for welded contacts. Verify that output from IO module turns off when above the set temperature. 4. Substitute a 1.2 kΩ resistor for T3, and verify that booster heater turns off. If not, replace IO module. 5. Verify that the booster-probe resistance is correct with respect to temperature (see table on pg. 24). If not, replace T3. 6. Replace float switch.
"F2 Service needed," "Check booster thermostat"	<ol style="list-style-type: none"> 1. Contactor to booster heater not turning off. 2. Faulty temperature input (P12) on IO module. 3. Faulty temperature probe (T3). 	<ol style="list-style-type: none"> 1. Check for welded contacts. Verify that output from IO module turns off when above the set temperature. 2. Substitute a 1.2 kΩ resistor for T3, and verify that booster heater turns off. If not, replace IO module. 3. Verify that the booster probe resistance is correct with respect to temperature (see table on pg. 24). If not, replace T3.
"F3 No water in wash tank," "Check inlet water and door"	<ol style="list-style-type: none"> 1. Malfunction of fill solenoid or fill relay. 2. Door is open, which inhibits fill mode. 3. Faulty door switch. 	<ol style="list-style-type: none"> 1. Replace faulty component. 2. Close door to activate door switch. 3. Replace or adjust door switch.
"F4 Service needed," "Check incoming power"	<ol style="list-style-type: none"> 1. Incoming power not properly connected. 2. L3 is missing (3-phase machines only). 	<ol style="list-style-type: none"> 1. Check connections to heater. 2. Verify that L3 is present and connected properly.
"F5 Service needed," "Check booster thermostat and high limit"	<ol style="list-style-type: none"> 1. Faulty temperature input (P12) on IO module. 2. Faulty temperature probe (T3). 3. Faulty high-limit switch. 4. Faulty booster heater. 5. Booster-heater contactor not energizing. 	<ol style="list-style-type: none"> 1. Substitute a 1.8 kΩ resistor for T3, and verify that booster heater turns on. If not, replace IO module. 2. Verify that T3 resistance is consistent with the table on pg. 24. If not, replace T3. 3. Replace high-limit switch. 4. Check booster heater for proper resistance. Replace if incorrect. 5. Verify that drive voltage to contactor coil is present during a call for heat and that contactor closes. If voltage is present, replace contactor. If voltage is not present, check wiring.

DISPLAY SHOWS	POSSIBLE CAUSES	REMEDY
"F6 Service needed," "No water in wash tank"	<ol style="list-style-type: none"> 1. Low or no water pressure. 2. Faulty inlet valve or fill relay. 3. Contactor to wash heater not turning off. 4. Faulty temperature input (T1) on IO module. 5. Faulty temperature probe (T1). 6. Faulty float switch allows heaters to operate with no water in tub. 	<ol style="list-style-type: none"> 1. Verify incoming water pressure is 10 ± 2 PSI. 2. Verify that fill relay is supplying voltage to fill solenoid. Replace faulty component. 3. Check for welded contacts. Verify that output from IO module turns off when above the set temperature. 4. Substitute a 1.2 kΩ resistor for T1, and verify that wash heater turns off. If not, replace IO module. 5. Verify that T1 resistance is correct with respect to temperature (see table on pg. 24). If not, replace T1. 6. Replace float switch.
"F7 Service needed," "Check wash tank thermostat"	<ol style="list-style-type: none"> 1. Contactor to wash heater not turning off. 2. Faulty temperature input (P10) on IO module. 3. Faulty temperature probe (T1). 	<ol style="list-style-type: none"> 1. Check for welded contacts. Verify that output from IO module turns off when above the set temperature. 2. Substitute a 1.2 kΩ resistor for T1, and verify that wash heater turns off. If not, replace IO module. 3. Verify that T1 resistance is correct with respect to temperature (see table on pg. 24). If not, replace T1.
"F8 No water in wash tank," "Check inlet water and door"	<ol style="list-style-type: none"> 1. Malfunction of fill solenoid or fill relay. 2. Door is open, which inhibits fill mode. 3. Faulty door switch. 	<ol style="list-style-type: none"> 1. Replace faulty solenoid or fill relay. 2. Close door to activate door switch. 3. Replace or adjust door switch.
"F9 Service needed," "Check incoming power"	<ol style="list-style-type: none"> 1. Incoming power not properly connected. 2. L3 is missing (3-phase machines only). 	<ol style="list-style-type: none"> 1. Check connections to heater. 2. Verify that L3 is present and connected properly.
"F10 Service needed," "Check wash tank thermostat and high limit"	<ol style="list-style-type: none"> 1. Faulty temperature input (T1) on I/O module. 2. Faulty temperature probe (T1). 3. Faulty high-limit switch. 4. Faulty wash heater. 5. Wash-heater contactor not energizing. 	<ol style="list-style-type: none"> 1. Substitute a 1.8 kΩ resistor for T1, and verify that wash heater turns on. If not, replace I/O module. 2. Verify that T1 resistance is correct with respect to temperature (see table on pg. 24). If not, replace T1. 3. Replace high-limit switch. 4. Check wash heater for proper resistance. Replace if incorrect. 5. Verify that drive voltage to contactor coil is present during a call for heat and that contactor closes. If voltage present, replace contactor. If voltage not present, check wiring.
F11 Service needed –check wash tank thermostat	Faulty temperature probe (T1).	Replace probe that connects to P10.

DISPLAY SHOWS	POSSIBLE CAUSES	REMEDY
"F12 Service needed," "Check booster thermostat"	Faulty temperature probe (T3).	Replace probe that connects to P13.
"F13 Communication error," "Check 6-pin cable"	<ol style="list-style-type: none"> 1. Loose connection in 6-pin cable between display board and I/O module. 2. Faulty 6-pin cable between display board and I/O module. 3. Faulty communication port on I/O module or display board. 	<ol style="list-style-type: none"> 1. Fully disconnect 6-pin cable at each end, and reconnect each end until a click is heard. 2. Inspect for broken wire or unseated terminal by gently pulling on each wire at each end of the cable. Reseat any loose terminals by inserting it fully into the housing using long-nosed pliers. Replace cable if broken wire is found. 3. Temporarily substitute a verified good display board, and check if F13 message recurs. If so, repeat substitution with a good I/O module.
"F14 Service needed," "Check incoming water pressure or pressure switch"	<ol style="list-style-type: none"> 1. Low or no water pressure. 2. Faulty pressure switch. 3. Faulty fill valve or fill valve not receiving power. 	<ol style="list-style-type: none"> 1. Verify correct PSI. 2. Replace pressure switch. 3. Check continuity and replace if faulty.
"F16 LLC violation"	Faulty or corroded probe.	Clean or replace probe.
"F17 Excessive inlet temp"	Inlet water supply too hot.	Ensure inlet water supply is at required temperature.

RESISTANCE-TO-TEMPERATURE VALUES

R (kΩ)	°F
11.58	69.8
10.37	75.2
9.30	80.6
7.78	89.6
3.05	140.0
2.54	150.8
2.18	159.8
1.58	179.6
1.45	185.0
1.33	190.4
1.16	199.4
0.96	212.0



WARNING! Inspection, testing, and repair of electrical equipment should only be performed by qualified service personnel. Certain procedures in this section require electrical tests or measurements while power is applied to the machine. Exercise extreme caution at all times. If test points are not easily accessible, disconnect power, attach test equipment, and reapply power to test. When replacing electrical parts, disconnect power at source circuit breaker.

OBSERVATION	POSSIBLE CAUSE	REMEDY
Water overflow from bottom of door.	<ol style="list-style-type: none"> 1. Clogged drain. 2. Machine not level. 3. Excessive inlet pressure. 4. Detergent foaming. 5. Wash/rinse arm end-cap missing. 	<ol style="list-style-type: none"> 1. Remove obstruction. 2. Level machine or increase height to the front. 3. Install pressure regulator or adjust if one is present. Ensure flow meets data plate specification. 4. Reduce detergent quantity. 5. Replace.
Wash motor doesn't operate on delime wash.	<ol style="list-style-type: none"> 1. Loose or broken wires. 2. Defective WASH/DELIME switch. 3. Defective motor starting relay. 4. Machine in FAULT mode and locked out. 	<ol style="list-style-type: none"> 1. Reconnect or replace wires in motor. 2. Verify WASH/DELIME switch triggers input on PLC. If not, check wiring/replace membrane. 3. Replace. 4. Review fault screen for active faults.
No water comes through the arms when the WASH/DELIME switch is depressed.	<ol style="list-style-type: none"> 1. Water not turned on. 2. Defective solenoid valve 	<ol style="list-style-type: none"> 1. Turn water on. 2. Replace solenoid valve.
Little or no water coming through the wash/rinse assemblies.	<ol style="list-style-type: none"> 1. Limed-up heads or piping. 2. Low water pressure. 	<ol style="list-style-type: none"> 1. Delime heads. 2. Adjust pressure regulator (not supplied) or increase pipe size to machine.
Rinse water runs continuously with breaker turned off.	<ol style="list-style-type: none"> 1. Defective plunger in solenoid valve. 2. Defective diaphragm in solenoid valve. 	<ol style="list-style-type: none"> 1. Replace. 2. Replace diaphragm.



WARNING! Inspection, testing, and repair of electrical equipment should only be performed by qualified service personnel. Certain procedures in this section require electrical tests or measurements while power is applied to the machine. Exercise extreme caution at all times. If test points are not easily accessible, disconnect power, attach test equipment, and reapply power to test. When replacing electrical parts, disconnect power at source circuit breaker.

OBSERVATION	POSSIBLE CAUSE	REMEDY
Wash temperature not at required temperature range.	<ol style="list-style-type: none"> 1. Water level low. 2. RTD setpoint too slow. 3. Defective RTD. 4. Wash heater defective. 5. Defective heater contactor R1. 	<ol style="list-style-type: none"> 1. Check water level. If low, run new fill cycle. 2. Check fault screen. Adjust wash temperature setpoint 3. Replace. 4. Replace heater element. 5. Replace.
Rinse water not at required temperature range.	<ol style="list-style-type: none"> 1. Incoming rinse water does not meet minimum criteria indicated on machine data plate. 2. RTD is defective. 3. Rinse heaters damaged. 4. Setpoint screens set low. 	<ol style="list-style-type: none"> 1. Adjust as required. 2. Replace if necessary. 3. Check amperages. Replace if necessary. 4. Adjust rinse tank setpoint.
Machine doesn't drain when POWER button is pressed.	<ol style="list-style-type: none"> 1. Drain clogged. 2. Defective drain valve. 	<ol style="list-style-type: none"> 1. Remove obstruction. 2. Replace.
No indication of pressure.	<ol style="list-style-type: none"> 1. Water turned off. 2. Pressure gauge failure. 	<ol style="list-style-type: none"> 1. Turn water on. 2. Replace pressure gauge.

NOTICE

Machines with serial numbers before 23D415452 have a different control panel. Click [here](#) to open earlier manual.

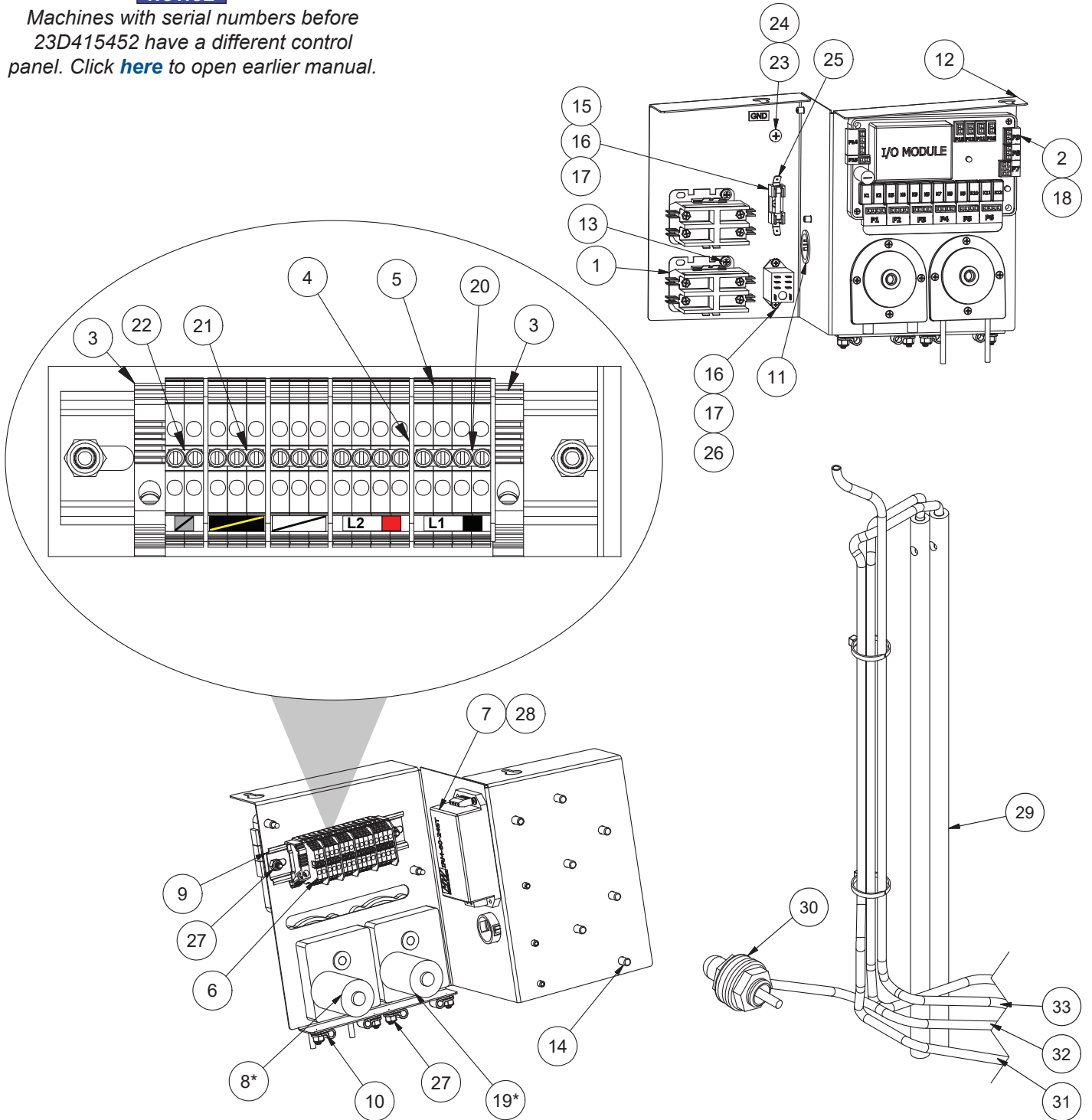

ITEM	QTY	DESCRIPTION	PART NUMBER
1	2	Contactora, 30 A, 240 VAC	05945-002-74-20
2	1	I/O Module	06401-005-10-88
3	2	End Bracket, Terminal	05999-004-90-66
4	5	Separator, Terminal Block	05999-004-90-67
5	16	Terminal Block, Single Level	05999-004-90-68
6	16	Tag, Marking	05999-004-90-72
7	1	Power Supply	05950-004-81-79
8*	1	Peri-pump Assembly, 14 RPM	05700-004-71-63
9	1	Din Rail, 5 3/4"	05700-021-72-75
10	4	P-clamp, 1/4" ID	05975-002-61-42
11	1	Bushing, 1 1/8"	05975-210-08-00
12	1	Bracket, Control Panel	05700-004-96-19
13	4	Screw, 10-32 x 1/2"	05305-002-80-88
14	9	Fastener, 10-32	05340-111-58-10
15	1	Fuse, Time-delay 8 A, 250 V	05920-004-85-54
16	5	Nut, Plated 6-32	05340-118-04-00
17	3	Screw, 6-32 x 3/8"	05305-002-25-91
18	2	Screw, 10-32 x 1"	05305-002-19-42
19*	1	Peri-pump Assembly	05700-005-00-29
20	2	Jumper Bars, 4-Pole	05999-004-41-80
21	2	Jumper Bars, 3-Pole	05999-004-90-71
22	1	Jumper Bars, 2-Pole	05999-004-41-79
23	1	Screw, 10-32 x 1/2"	05305-011-39-36
24	1	Decal, Ground	09905-011-86-86
25	1	Fuser Holder, One Only	05920-002-42-13
26	1	Relay, 10 A, 240 VAC	05945-111-89-75
27	6	Locknut, 10-24 Hex with Nylon Insert	05310-373-01-00
28	2	Screw, 6-32 x 1/2"	05305-004-23-63
29	2	Stiffener, Chemical Tube	05700-002-66-49
30	1	Chemical Port Assembly	05700-004-30-86
31	1	Tubing, Blue, 1/4"	04720-604-11-00
32	1	Tubing, Red, 1/4"	04720-601-12-00
33	1	Tubing, Clear, 1/8"	04720-111-58-09

*See HT Chemical Feeder Pumps section for peri-pump components.

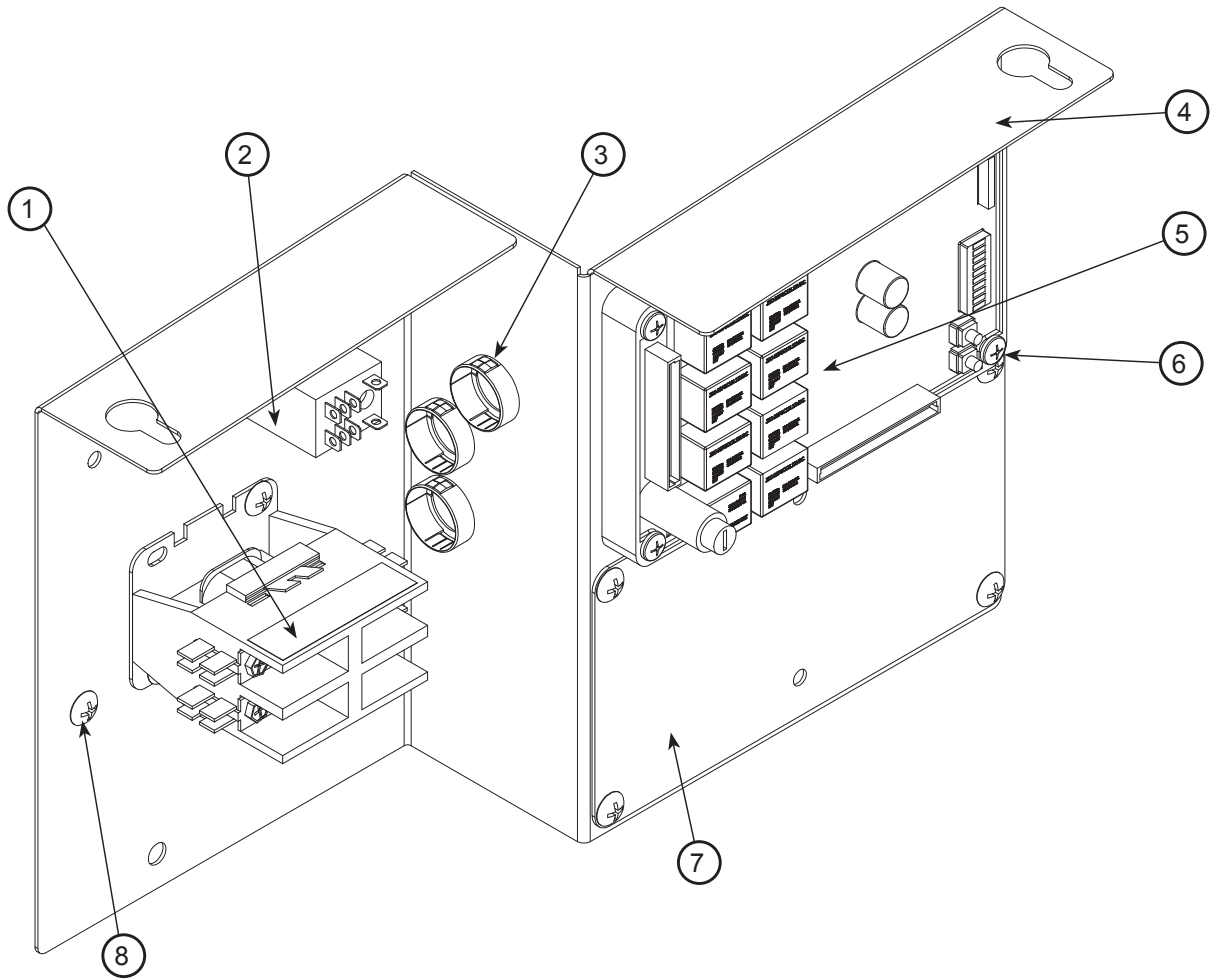

ITEM	QTY	DESCRIPTION	PART NUMBER
1	1	Contactors, 110 V	05945-109-05-69
2	1	Relay, Omron	05945-002-47-41
3	3	Open/Closed Bushing	05975-003-35-21
4	1	Control Panel Weldment	05700-004-35-76
5	1	Universal Timer	05945-003-75-23
6	4	Screw, 10-32 x 1"	05305-002-19-42
7	1	Thermostat Plate	05700-004-37-67
8	7	Screw, 10-32 x 3/8"	05305-173-12-00

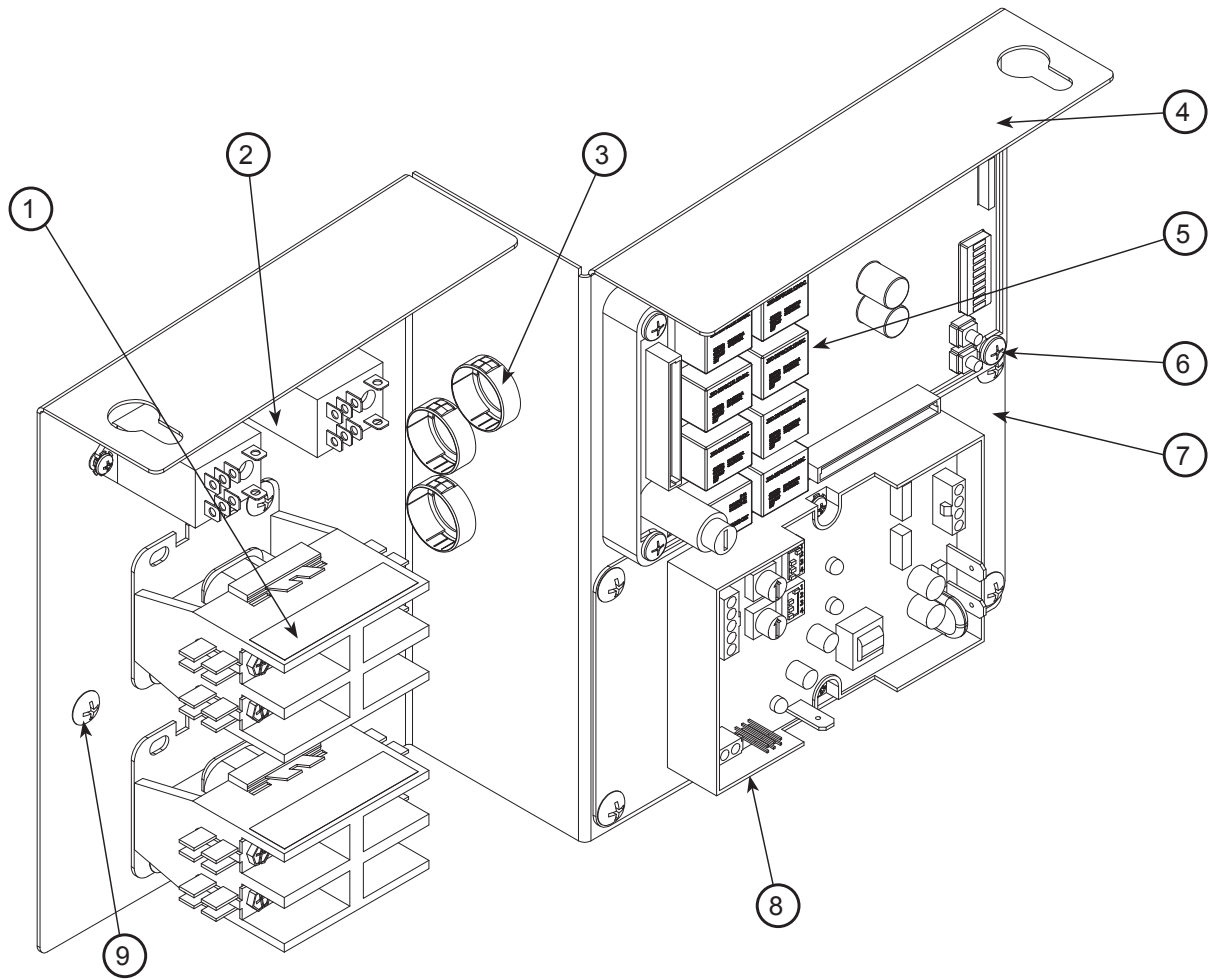

ITEM	QTY	DESCRIPTION	PART NUMBER
1	2	Contactors, 110 V	05945-109-05-69
2	2	Relay, Omron	05945-002-47-41
3	3	Open/Closed Bushing	05975-003-35-21
4	1	Control Panel Weldment	05700-004-35-76
5	1	Universal Timer	05945-003-75-23
6	4	Screw, 10-32 x 1"	05305-002-19-42
7	1	Thermostat Plate	05700-004-37-67
8	1	Thermostat, Electric	06685-004-17-27
9	7	Screw, 10-32 x 3/8"	05305-173-12-00

NOTICE

Machines with serial numbers before 23D415452 have a different display panel. Click [here](#) to open earlier manual.

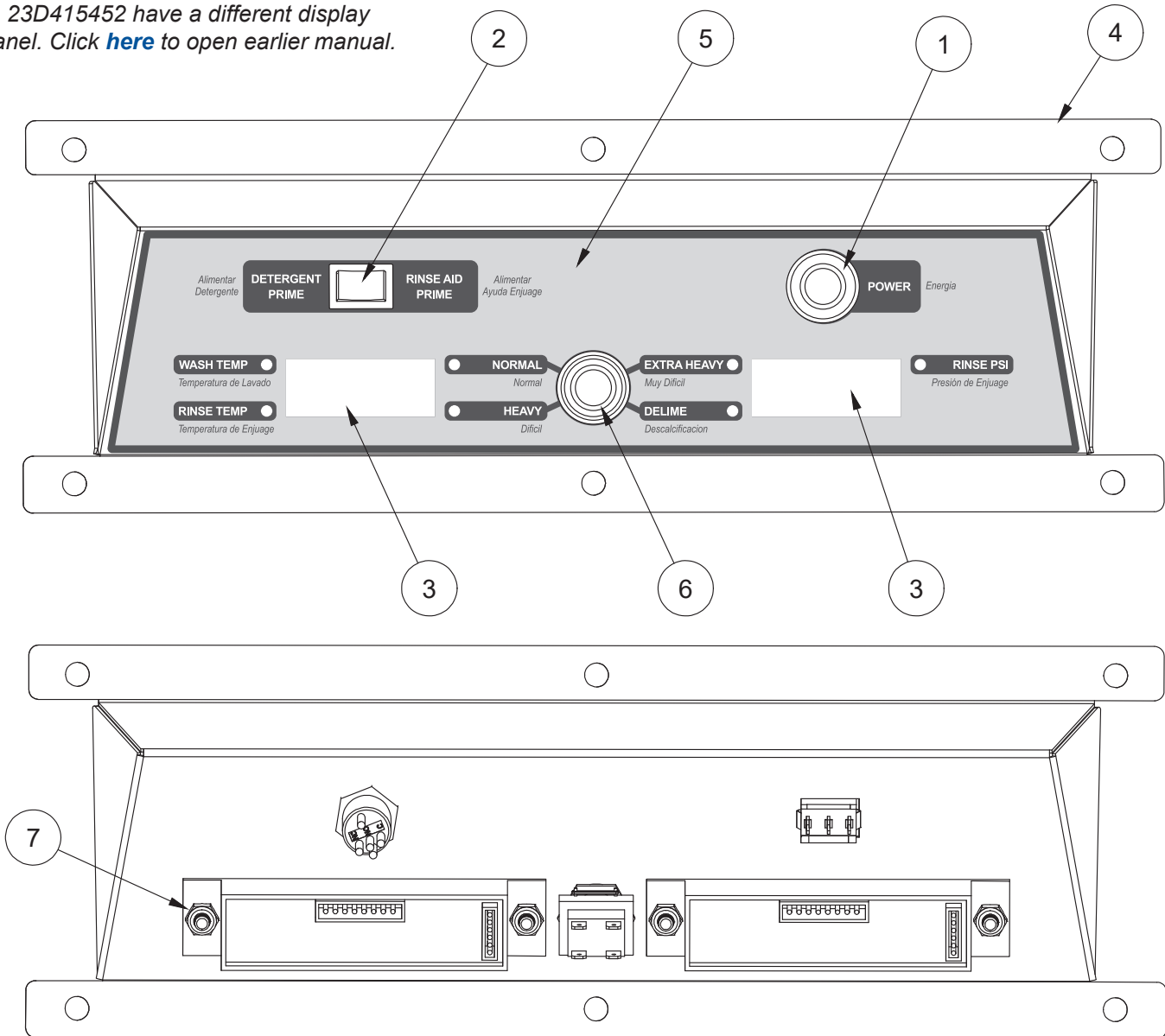

ITEM	QTY	DESCRIPTION	PART NUMBER
1	1	Switch, Power	05930-004-85-60
2	1	Switch, Prime	05930-004-97-47
3	2	Display, LED	05945-004-85-61
4	1	Bracket, Display Panel	05700-005-07-33
5	1	Decal, Display Panel	09905-005-06-11
6	1	Switch, Cycle	05700-003-14-91
7	4	Locknut, 10-24 Hex with Nylon Insert	05310-373-01-00

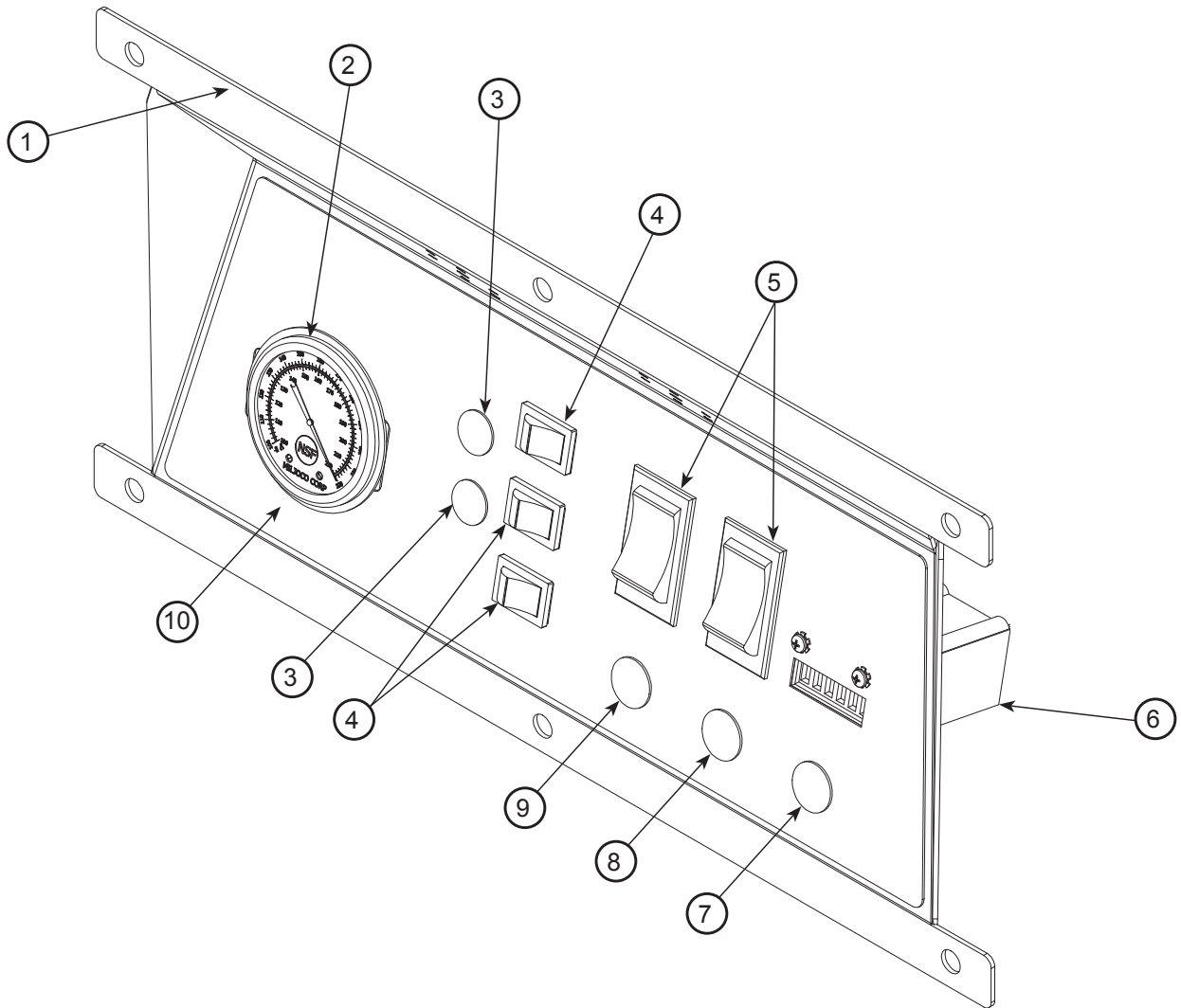

ITEM	QTY	DESCRIPTION	PART NUMBER
1	1	Bracket, Control Panel	05700-004-37-73
2	1	Thermometer, 48" Rinse	06685-004-31-47
3	2	Light, Red	05945-504-07-18
4	3	Prime Switch	05930-011-49-54
5	2	Switch	05930-011-49-55
6	1	Counter	05990-111-35-38
7	1	Light, Amber	05945-111-44-44
8	1	Light, Green	05945-111-44-43
9	1	Light, Red	05945-111-44-45
10	1	Decal, Display Panel	09905-004-37-72

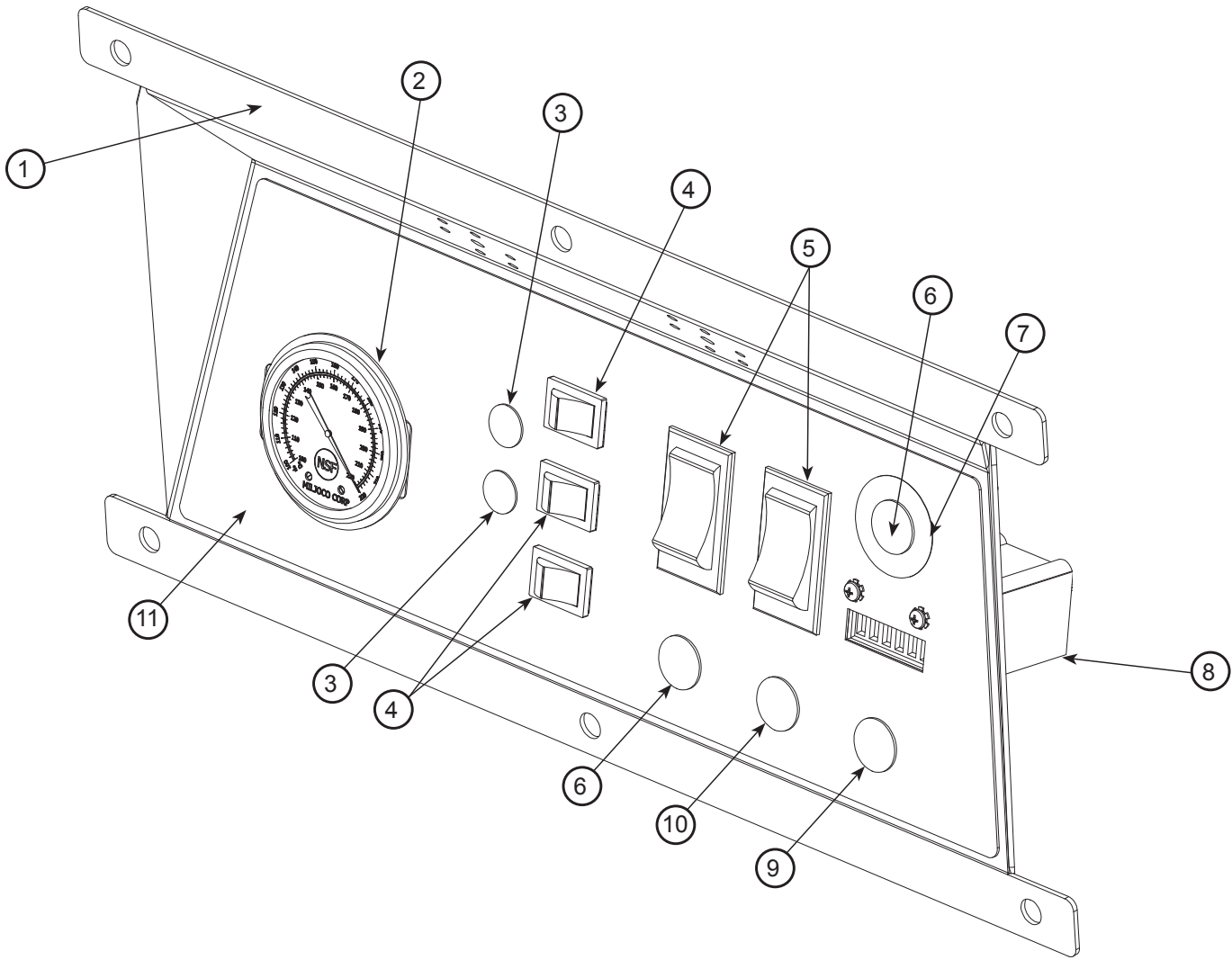

ITEM	QTY	DESCRIPTION	PART NUMBER
1	1	Bracket, Control Panel	05700-004-37-73
2	1	Thermometer, 48" Rinse	06685-004-31-47
3	2	Light, Red	05945-504-07-18
4	3	Prime Switch	05930-011-49-54
5	2	Switch	05930-011-49-55
6	2	Light, Red	05945-111-44-45
7	1	Decal, Hi-Limit Ring	09905-004-37-89
8	1	Counter	05990-111-35-38
9	1	Light, Amber	05945-111-44-44
10	1	Light, Green	05945-111-44-43
11	1	Decal, Display Panel	09905-004-37-72

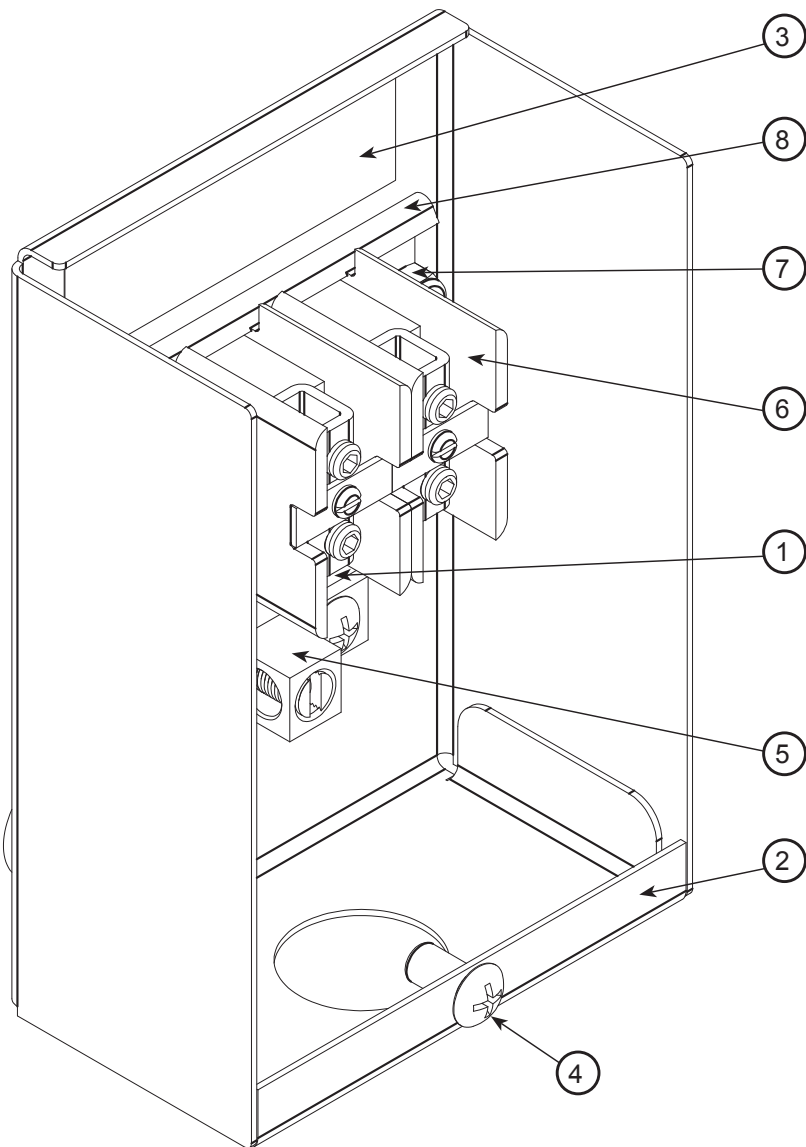

ITEM	QTY	DESCRIPTION	PART NUMBER
1	1	Decal, Power Connections, HT	09905-011-62-72
		Decal, Power Connections, LT/LT-H	09905-011-47-64
2	1	Terminal Block Box	05700-003-27-69
	1	Terminal Box Cover (Not Shown)	05700-003-27-70
3	1	Decal, Copper Conductors	09905-011-47-35
4	2	Screw, 10-32 x 1/2"	05305-011-39-36
5	1	Ground Lug	05940-200-76-00
6	2	Terminal Block	05940-500-02-19
7	1	Locknut, 10-24 SS Hex with Nylon Insert	05310-373-01-00
8	1	Terminal Block Track	05700-000-43-60

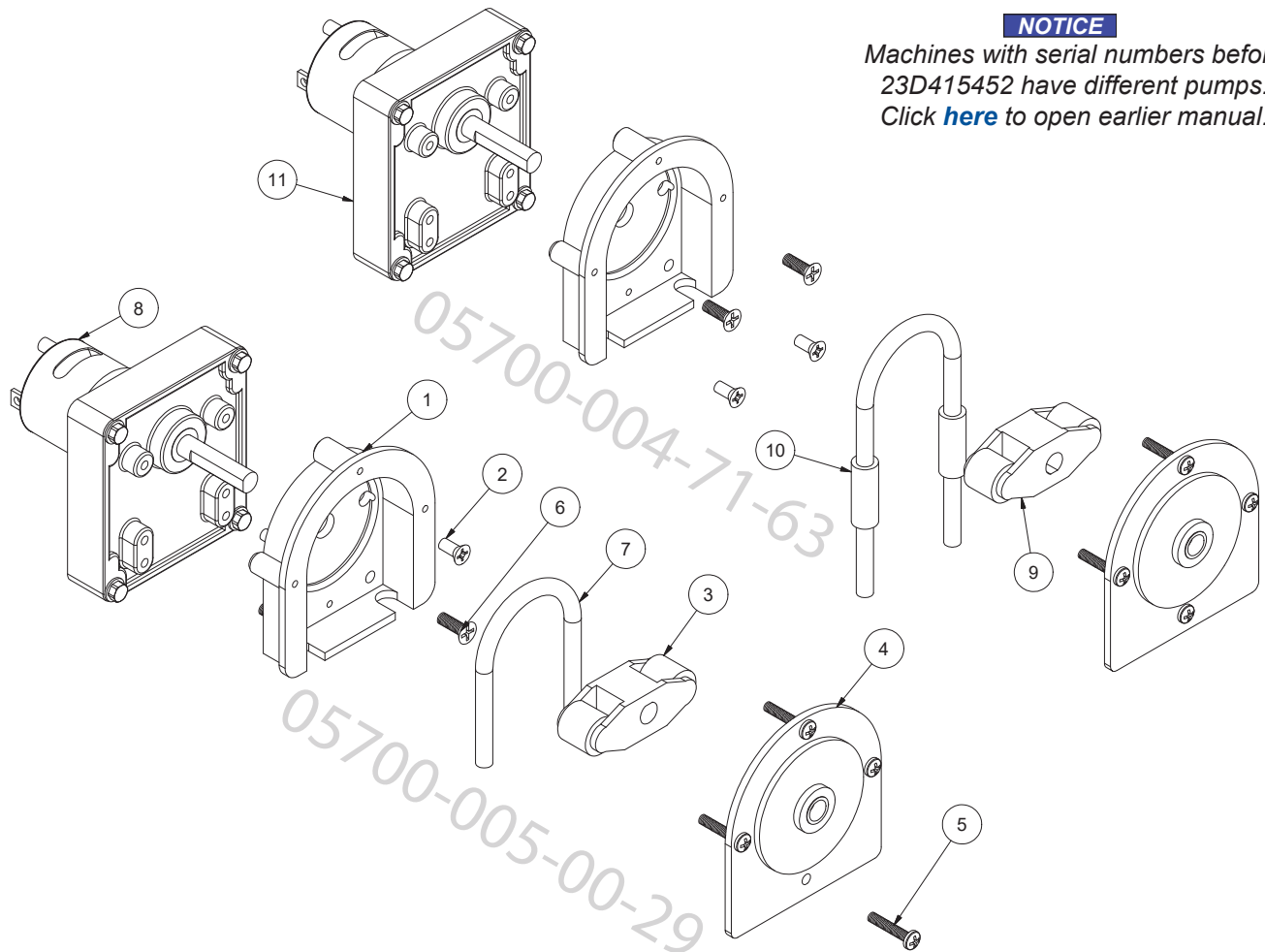
**NOTICE**

Machines with serial numbers before 23D415452 have different pumps. Click [here](#) to open earlier manual.

ITEM	QTY	DESCRIPTION	PART NUMBER
1	2	Pump Housing	04320-111-37-09
2	4	Screw, 8-32 x 3/8" Phillips	05305-011-37-07
3	1	Roller, Plastic	04320-002-82-28
4	2	Pump Cover	04320-111-37-08
5	8	Screw, 6-32 x 3/4" Phillips	05305-011-37-05
6	4	Screw, 8-32 x 1/2" Phillips	05305-011-37-06
7	1	Tube, Squeeze, 8"	05700-003-22-89
8	1	Motor, 38 RPM	04320-004-99-36
9	1	Roller, Plastic	04320-111-65-27
10	1	Tube, Squeeze, 9"	05700-011-65-21
11	1	Motor, 14 RPM	04320-011-63-33

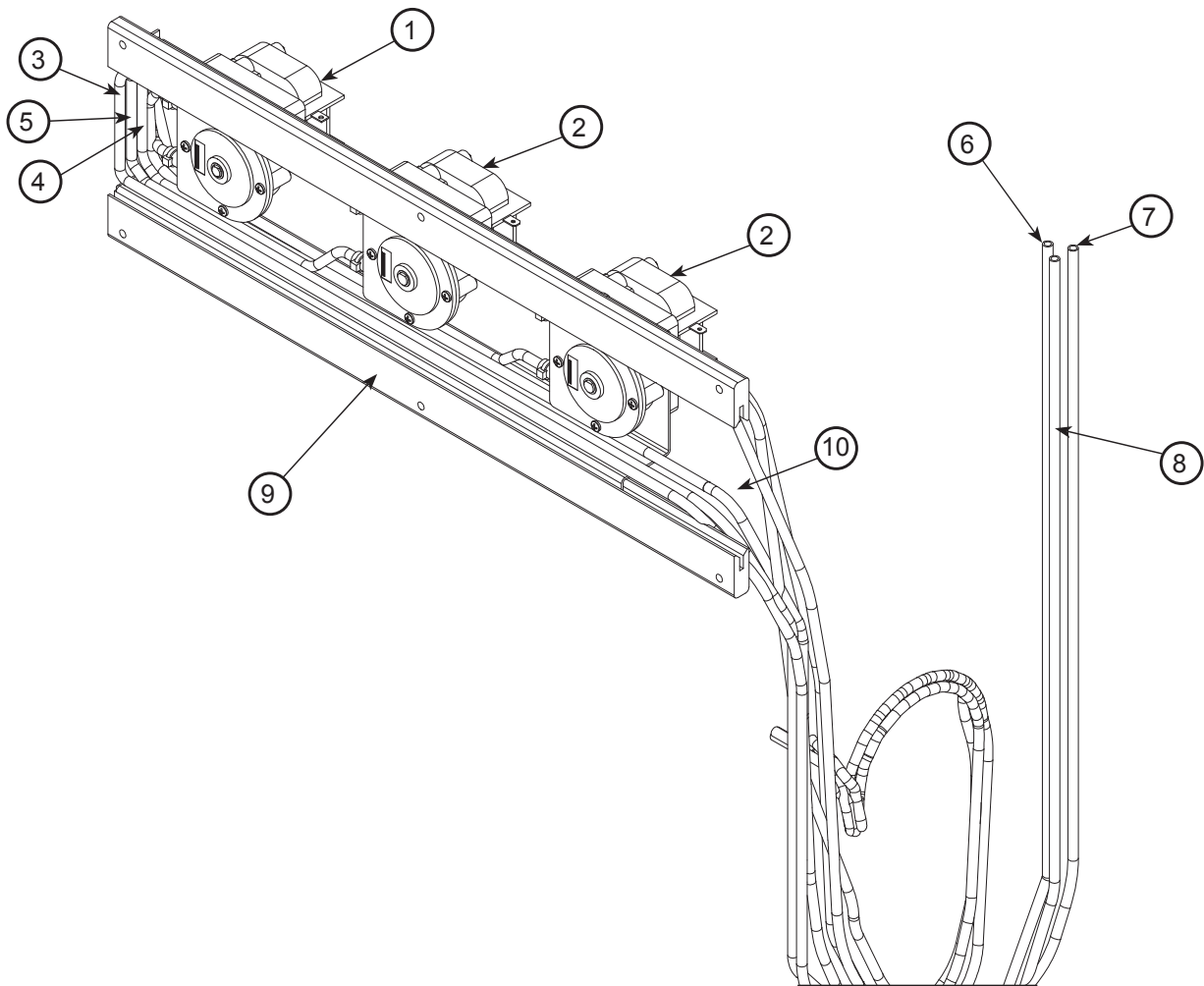

ITEM	QTY	DESCRIPTION	PART NUMBER
1	1	Complete Peri-pump Assembly, 14 RPM*	05700-004-71-61
2	2	Complete Peri-pump Assembly, 36 RPM*	05700-004-71-60
3	1	Tubing, White, 1/4" x 48"	05700-002-62-13
4	1	Tubing, Blue, 1/4" x 48"	05700-002-62-11
5	1	Tubing, Red, 1/4" x 48"	05700-002-62-12
6	1	Tubing, White, 1/4" x 100"	05700-003-20-67
7	1	Tubing, Blue, 1/4" x 100"	05700-003-20-68
8	1	Tubing, Red, 1/4" x 100"	05700-003-03-45
9	1	Track Mount Assembly	05700-004-37-94
10	1	Peri-pump Channel	05700-003-53-25

*Components on next page.

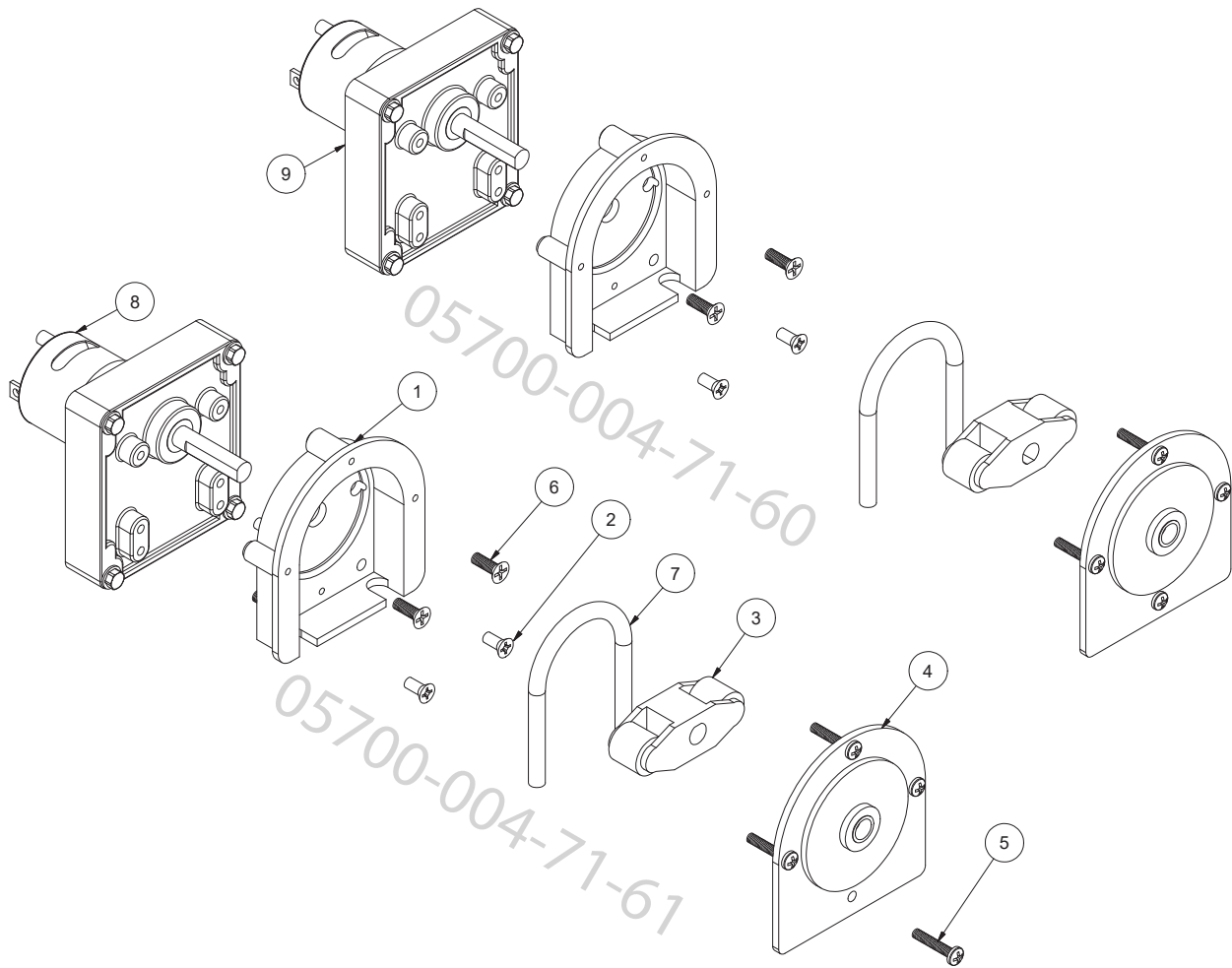

ITEM	QTY	DESCRIPTION	PART NUMBER
1	2	Pump Housing	04320-111-37-09
2	4	Screw, 8-32 x 3/8" Phillips	05305-011-37-07
3	1	Roller, Plastic	04320-002-82-28
4	2	Pump Cover	04320-111-37-08
5	8	Screw, 6-32 x 3/4" Phillips	05305-011-37-05
6	4	Screw, 8-32 x 1/2" Phillips	05305-011-37-06
7	1	Tube, Squeeze, 8"	05700-003-22-89
8	1	Motor, 14 RPM	04320-111-35-13
9	1	Motor, 36 RPM	04320-111-35-14

NOTICE

Machines with serial numbers before 23D415452 have different plumbing.
Click [here](#) to open earlier manual.

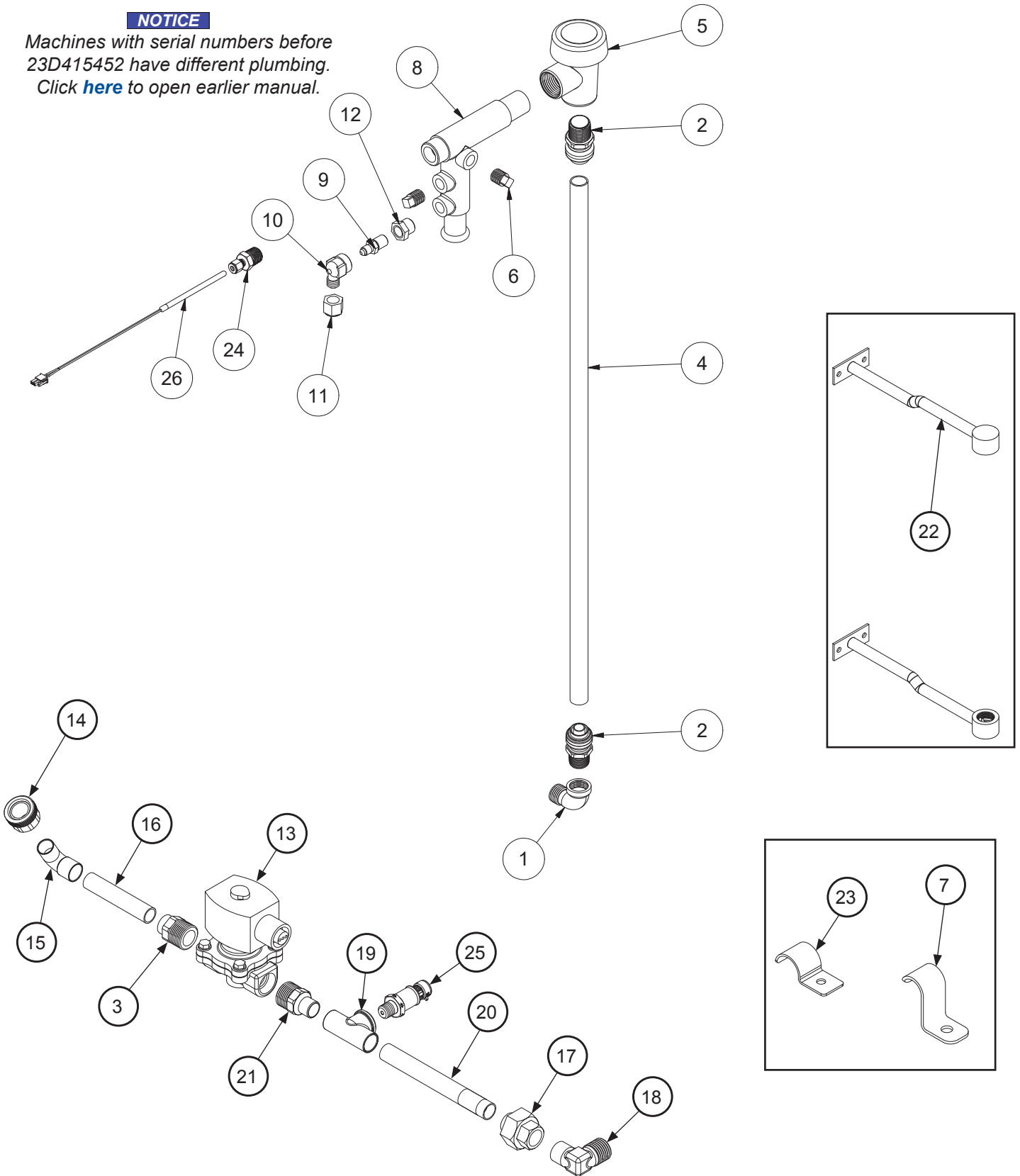

ITEM	QTY	DESCRIPTION	PART NUMBER
1	1	Elbow, 1/2" 90-Degree	04730-206-08-00
2	2	Adapter, 1/2" x 1/2"	04730-004-97-23
3	1	Adapter, Male	04730-401-03-01
4	1	Tube, Copper 1/2" x 22"	05700-003-32-16
5	1	Vacuum Breaker	04820-003-06-13
6	2	Plug, 1/4" Brass	04730-209-01-00
7	1	Pipe Clamp	05700-011-38-62
8	1	Injector Adapter	05700-031-40-44
9	1	Check Valve	04820-111-51-14
10	1	Fitting, Outlet Elbow	04820-111-51-18
11	1	Nut, Tube	04730-011-59-45
12	1	Bushing, 1/4" x 1/8"	04730-003-05-61
13	1	Valve, 1/2" 208/60	04810-003-71-56
14	1	Hose Adapter	04720-004-24-68
15	1	Elbow, 1/2"	04730-406-31-01
16	1	Copper Tube 1/2" x 3"	05700-003-36-25
17	1	Union, 1/2"	04730-412-05-01
18	1	Elbow, 1/2" 90-Degree	04730-406-32-01
19	1	Tee, 1/2" x 1/2" x 1/4" Female	04730-411-25-01
20	1	Copper Pipe, 4 3/4" Long	05700-002-91-02
21	1	Adapter, 1/2" Male	04730-011-59-53
22	2	Rinse Hub Weldment	05700-021-38-31
23	2	Pipe Clamp (Side of Unit)	05700-000-35-05
24	1	Fitting, 1/2" x 1/4"	05700-004-36-74
25	1	Pressure Transducer	05945-004-84-32
26	1	Thermistor Probe, 4"	06685-004-34-58

NOTICE Use teflon tape on threads. Do NOT use "pipe dope."

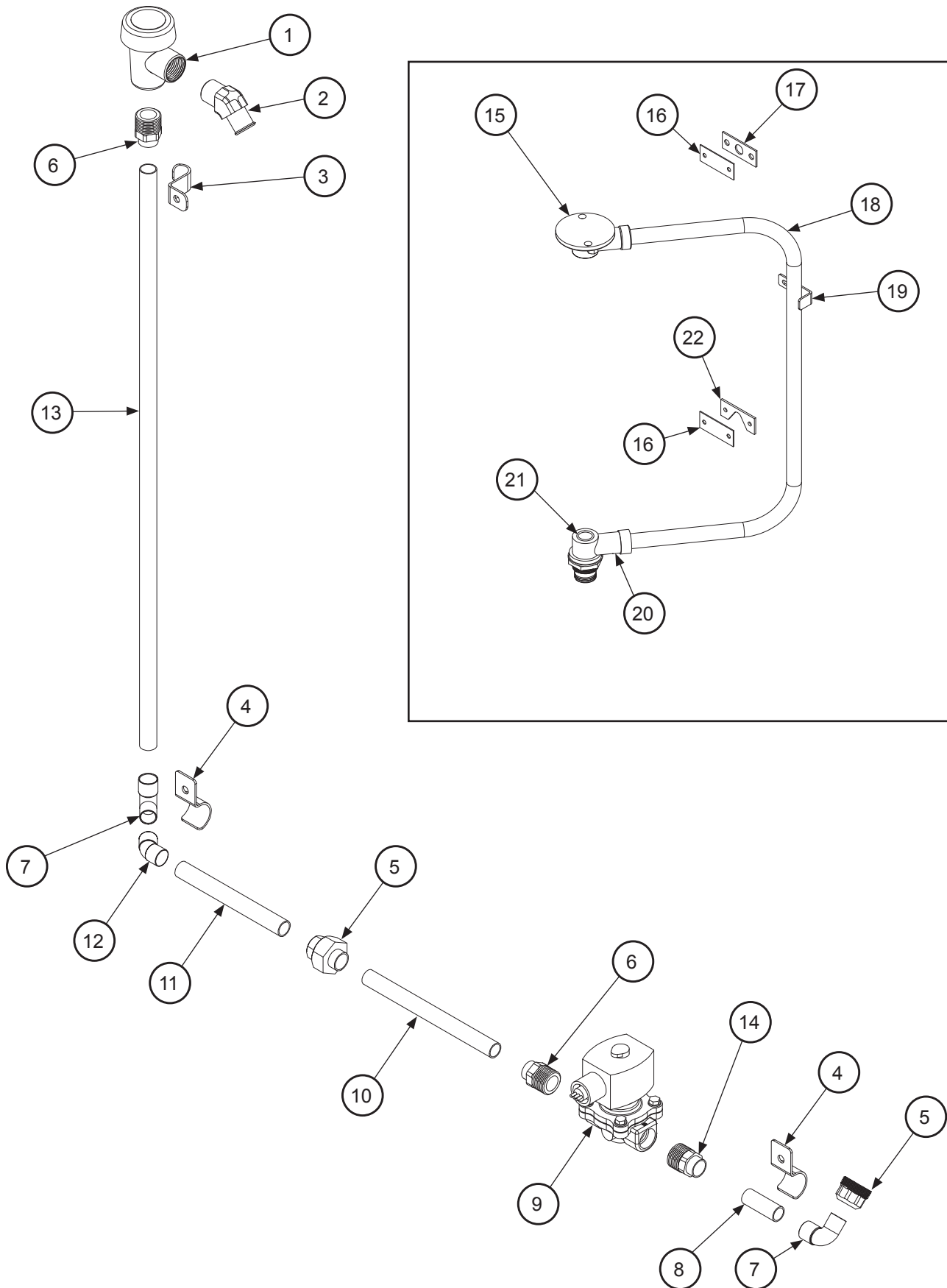

ITEM	QTY	DESCRIPTION	PART NUMBER
1	1	Vacuum Breaker	04820-003-06-13
2	1	Elbow, 1/2" NPT x 3/4" Hose, 45-Degree	04730-003-29-22
3	1	Pipe Clamp	05700-011-38-62
4	2	Pipe Clamp (Side of Unit)	05700-000-35-05
5	1	Hose Union, 1/2"	04720-004-24-68
6	1	Male Adapter	04730-401-03-01
7	2	Elbow, 1/2"	04730-406-31-01
8	1	Copper Pipe, 1/2" x 1 3/8"	05700-004-69-44
9	1	Valve, 1/2"	04810-003-71-55
10	1	Copper Pipe, 1/2" x 6 1/2"	05700-002-60-71
11	1	Copper Pipe, 1/2" x 5 1/4"	05700-002-04-92
12	1	Elbow, 1/2", 45-Degree	04730-011-67-77
13	1	Copper Pipe, 1/2" x 25 1/2"	05700-011-59-85
14	1	Male Adapter	04730-011-59-53
15	1	Upper Manifold	05700-031-34-82
16	2	Rinse Plumbing Plate	05700-011-82-86
17	1	Rinse Plumbing Gasket	05330-111-42-81
18	1	Manifold	05700-002-13-75
19	1	Manifold Tube Position Bracket	05700-011-34-63
20	1	Lower Manifold	05700-021-52-80
21	1	O-ring	05330-002-60-69
22	1	Deflector Plate	05700-002-62-49

NOTICE Use teflon tape on threads. Do NOT use "pipe dope."

SHOCK ABSORBER (WATER ARRESTOR) OPTION

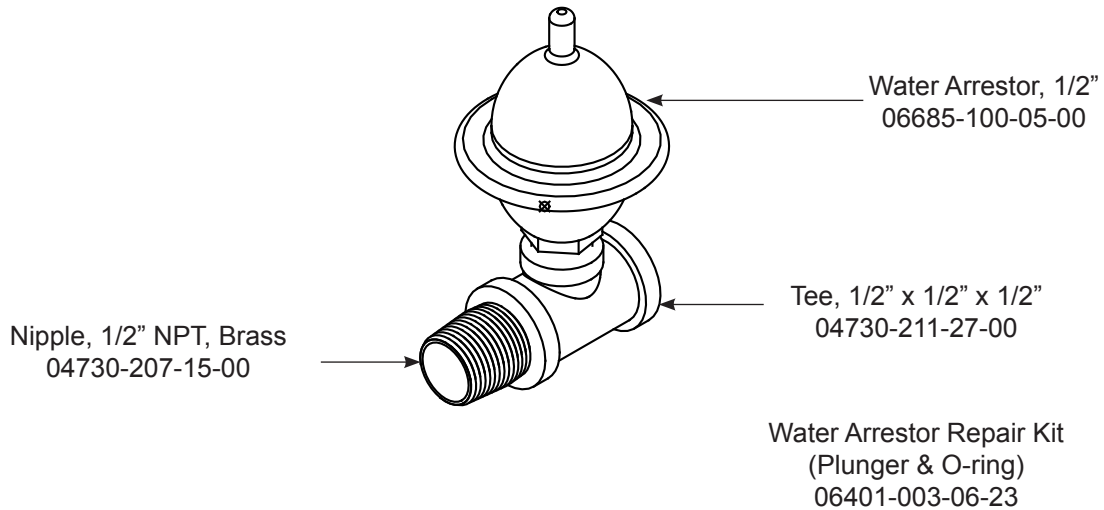

PRESSURE REGULATING VALVE (PRV) OPTION

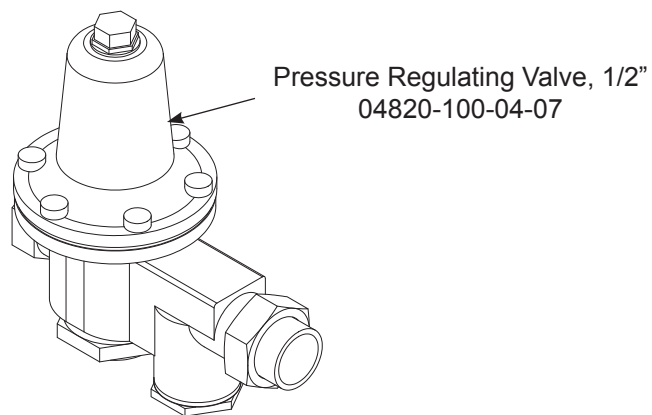

SCALE PREVENTION SYSTEM (SPS) OPTION

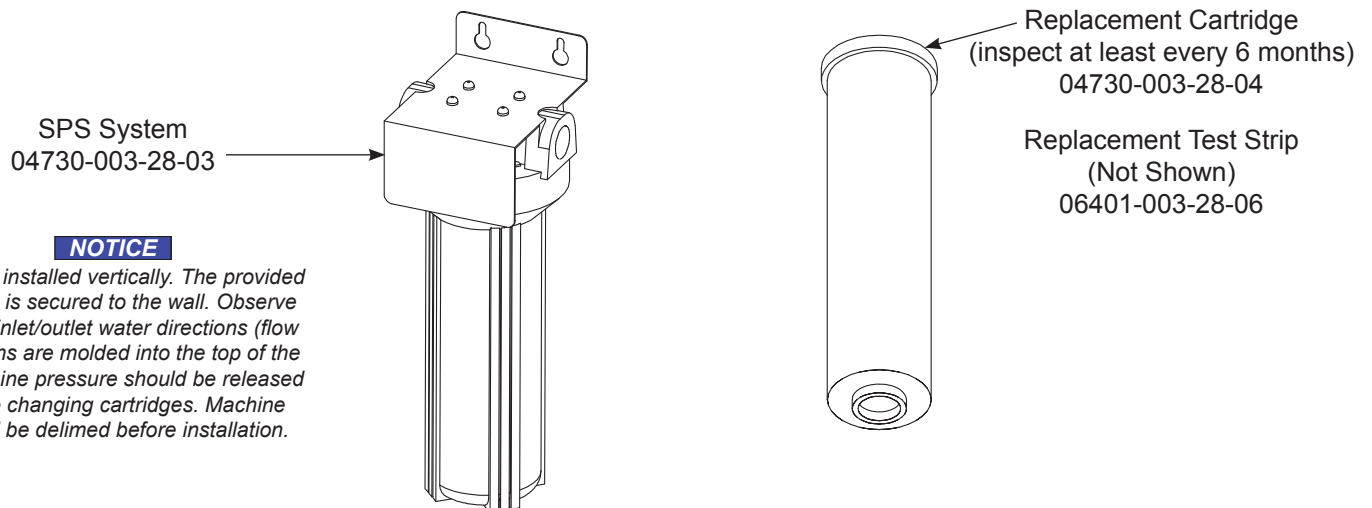

NOTICE

Must be installed vertically. The provided bracket is secured to the wall. Observe proper inlet/outlet water directions (flow directions are molded into the top of the head). Line pressure should be released before changing cartridges. Machine should be delimed before installation.

VACUUM BREAKER ASSEMBLY

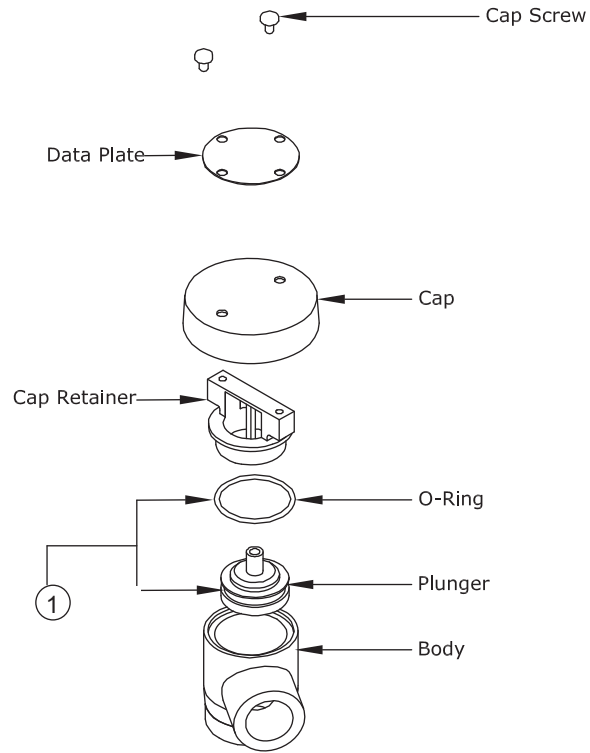

ITEM	QTY	DESCRIPTION	PART NUMBER
1	1	Components of Repair Kit	06401-003-06-23
		Complete Vacuum Breaker Assembly 1/2" NPT	04820-003-06-13

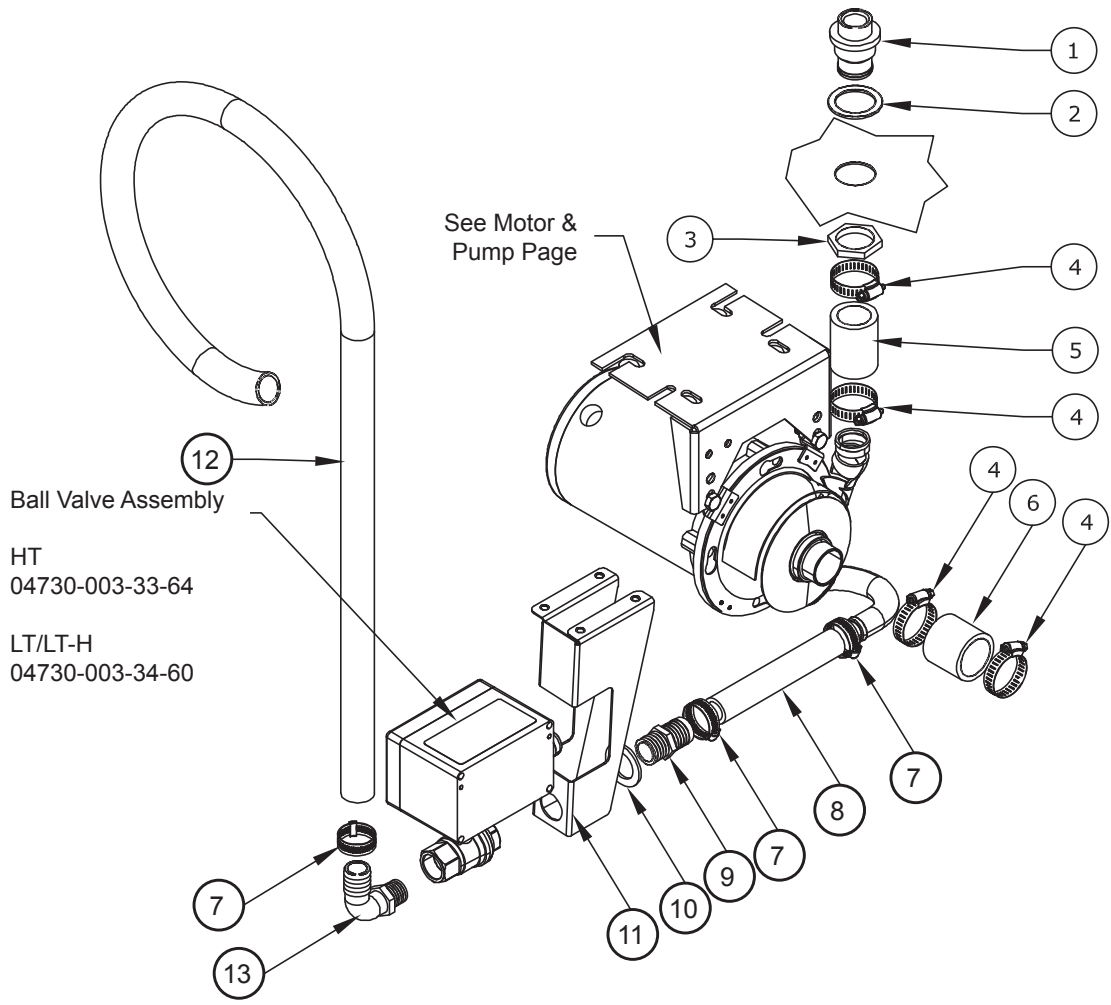

ITEM	QTY	DESCRIPTION	PART NUMBER
1	1	Hub, Discharge Machine	05700-021-37-90
2	1	Gasket, Manifold	05330-200-23-00
3	1	Nut, Jam 1 1/2-12	05700-000-86-23
4	4	Hose Clamp, 1 5/16" - 2 1/4" #28	04730-719-01-37
5	1	Hose, 1 1/4" x 2 1/4" Reinforced	05700-011-44-48
6	1	Hose, Bottom Manifold Pump	05700-001-22-92
7	3	Clamp, 3/16" to 1 1/2"	04730-719-06-09
8	1	Discharge Hose	05700-004-43-76
9	1	Hosebarb, 1" x 3/4" NPT Polypropylene	04730-011-65-86
10	1	Spacer, Drain Valve	05700-003-31-93
11	1	Bracket, Drain Valve Support	05700-004-35-85
12	1	Hose, 1" ID x 6' Long	04720-004-50-76
13	1	Hose-barb, 90-Degree 1" x 3/4" NPT	04730-011-65-87

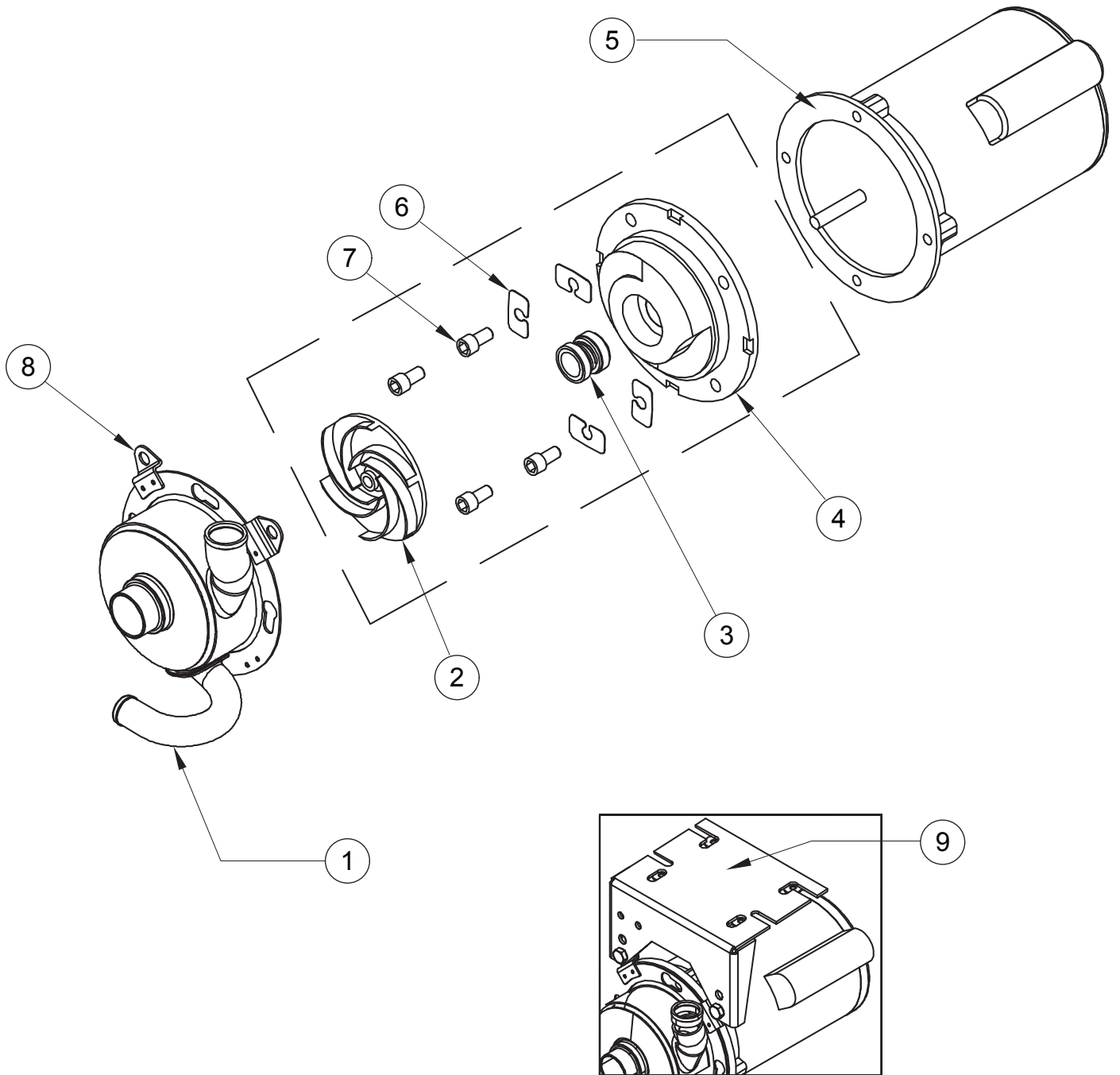

Complete Pump & Motor Assembly, DishStar HT/LT/LT-H
06105-004-35-22

ITEM	QTY	DESCRIPTION	PART NUMBER
1	1	Pump Casing SS, 60 Hz	05700-002-85-00
2	1	Impeller, 60 Hz	05700-002-81-86
3	1	Mechanical Seal, 60 Hz	05330-002-34-22
4	1	Seal Plate, 60 Hz	05700-002-81-87
	1	Case O-ring, 60 Hz	05330-002-81-83
	1	Drain Plug (Not Shown)	04730-002-81-89
5	1	Motor Only, HT/LT/LT-H	06105-004-32-04
6	1	Shim Kit	05700-002-82-58
7	1	Case Capscrew	05305-356-04-00
8	2	Bolt, 3/8"	05305-276-03-00
	2	Lock washer, 3/8"	05311-276-01-00
	2	Nut Hex, 3/8-16	05310-276-01-00
9	1	Mounting Bracket	05700-003-31-58

Complete Wash Arm Assembly
 1 per Unit on HT
 2 per Unit on LT/LT-H
 05700-021-39-23

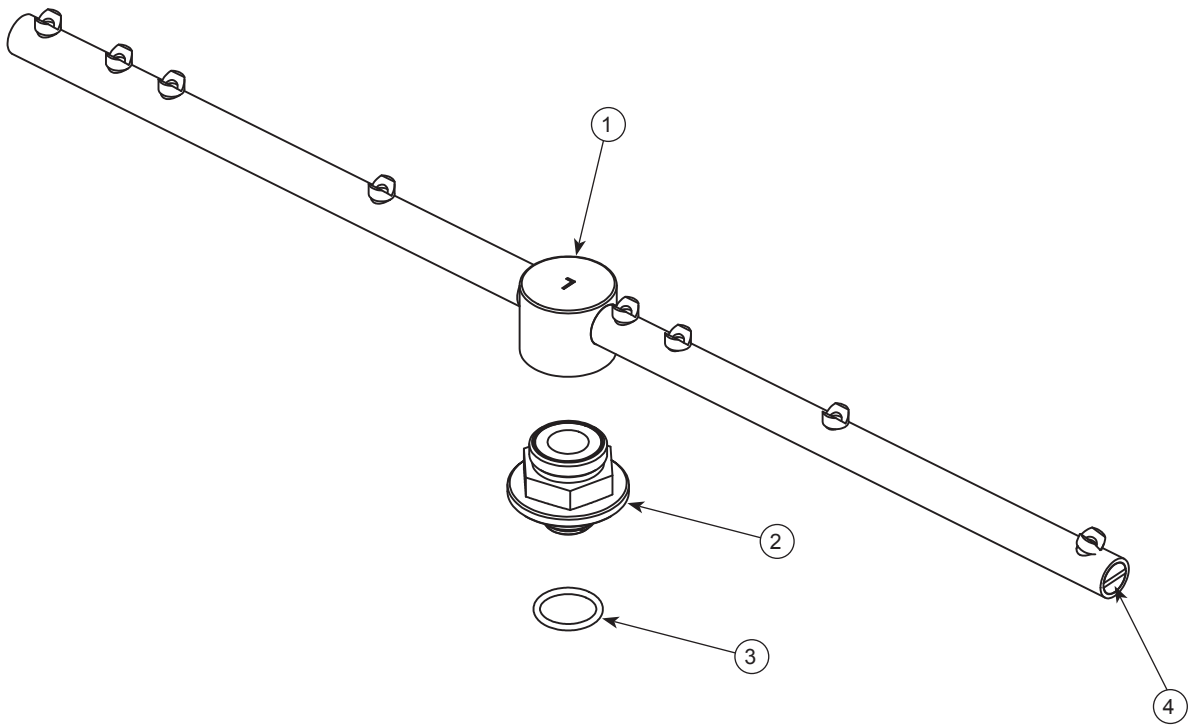

ITEM	QTY	DESCRIPTION	PART NUMBER
1	1	Wash Arm with End-cap	05700-021-46-58
2	1	Bearing, Assembly	05700-021-35-97
3	1	O-ring	05330-002-60-69
4	2	End-cap, Wash Arm	05700-003-31-59

Complete Rinse Arm Assembly

2 per Unit on HT

0 per Unit on LT/LT-H

05700-031-39-21

Rinse Arm Bearing Kit

06401-004-57-50

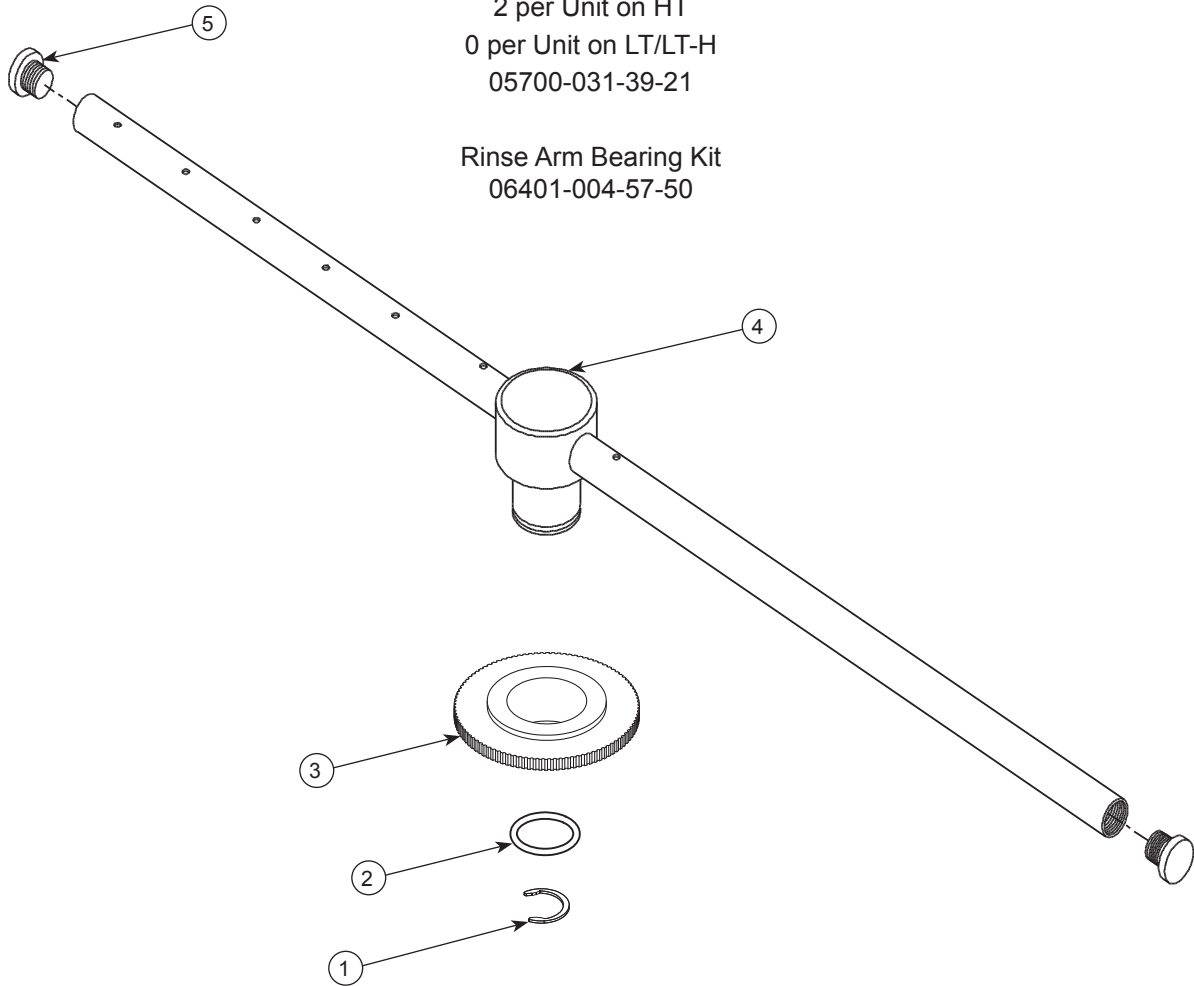

ITEM	QTY	DESCRIPTION	PART NUMBER
1	1	Retaining Ring	05340-112-01-11
2	1	O-ring (included in item #3)	05330-002-60-69
3	1	Bearing Assembly, Rinse Arm	05700-004-54-71
4	1	Rinse Arm	05700-031-38-30
5	2	End-cap, Rinse Arm	04730-111-60-41

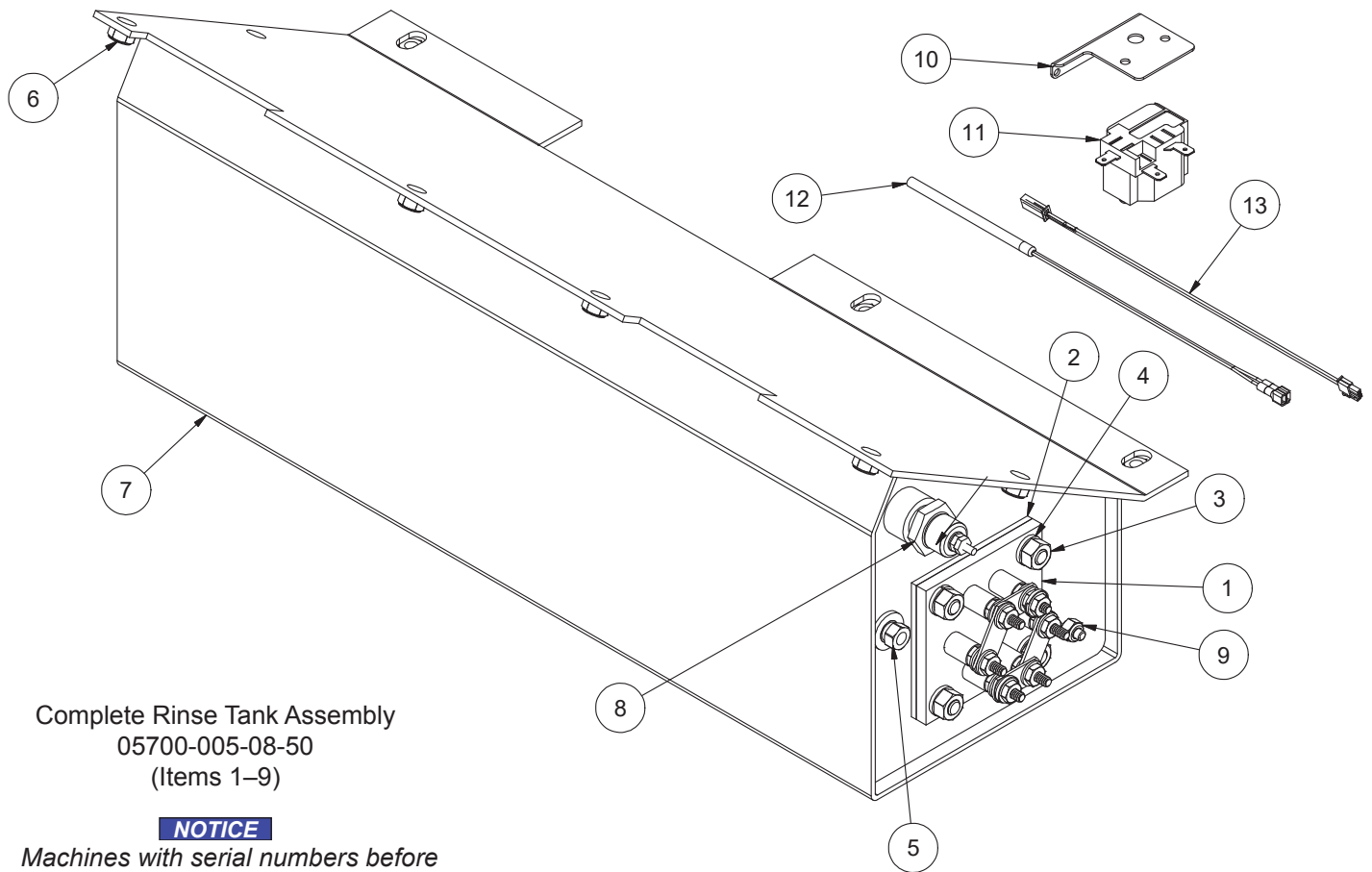

Complete Rinse Tank Assembly
05700-005-08-50
(Items 1–9)

NOTICE

Machines with serial numbers before
23D415452 have a different rinse tank.
Click [here](#) to open earlier manual.

ITEM	QTY	DESCRIPTION	PART NUMBER
1	1	Heater, 8.2 kW, 230 V	04540-111-43-21
2	1	Gasket, Heater	05330-011-47-79
3	4	Lock Washer, 5/16" Split	05311-275-01-00
4	4	Nut, 5/16-18 SS Hex	05310-275-01-00
5	1	Fitting, 1/4" Imperial Brass	05310-924-02-05
6	9	Locknut, 1/4-20 SS Hex with Nylon Insert	05310-374-01-00
7	1	Rinse Tank Weldment	05700-005-08-49
8	1	Probe, High Water	06680-200-02-68
9	1	Locknut, 10/24-20 SS Hex with Nylon Insert	05310-373-01-00
10	1	Thermostat Bracket	05700-004-36-37
11	1	High Limit Thermostat	05930-004-33-15
12	1	Probe, Thermister 4"	06685-004-34-58
13	1	Cable, Temperature Probe	05700-004-33-23

Complete Door Assembly
05700-005-07-44

NOTICE

Machines with serial numbers before 23D415452 have a different door. Click [here](#) to open earlier manual.

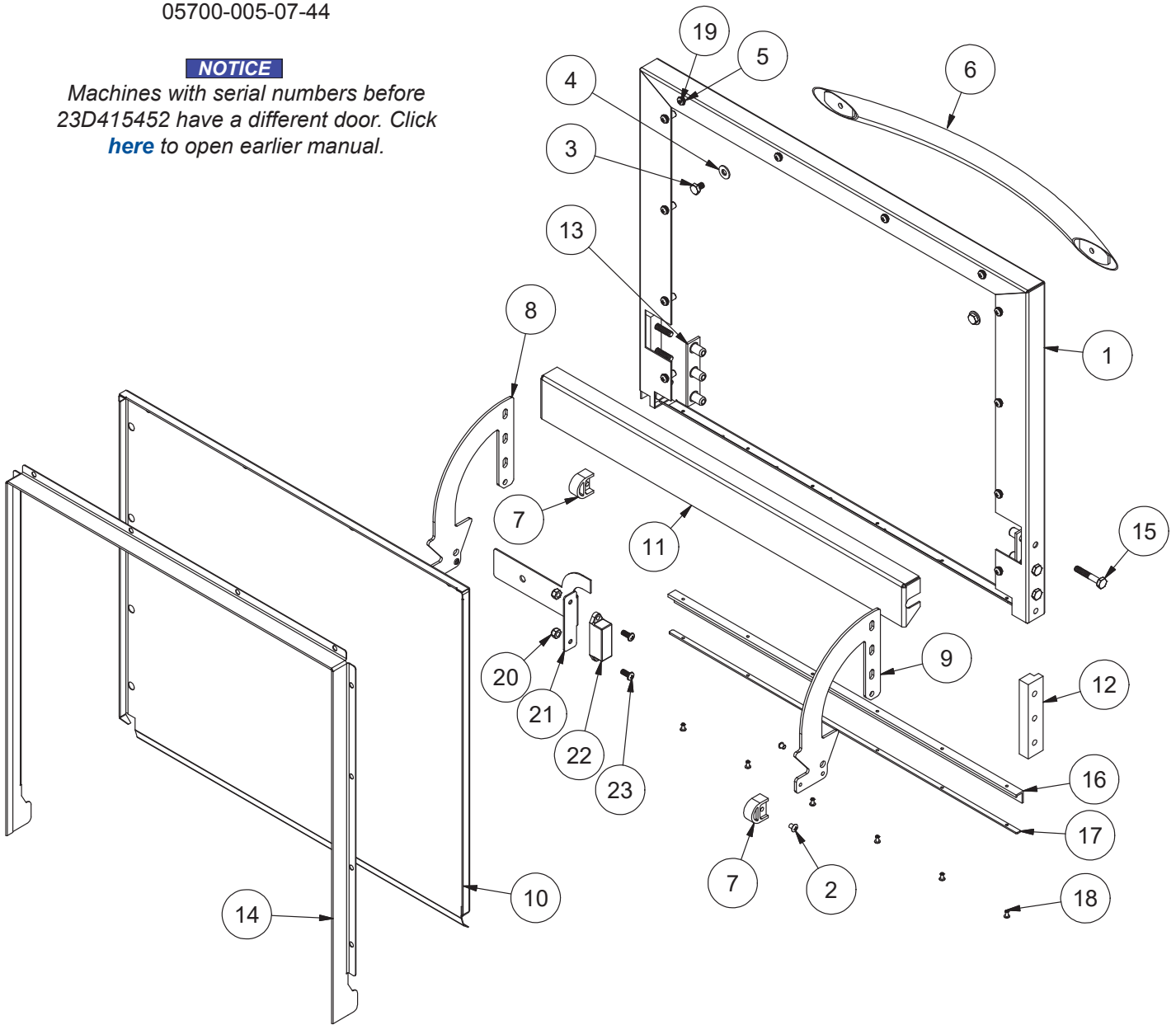

ITEM	QTY	DESCRIPTION	PART NUMBER
1	1	Outer Door Weldment	05700-005-07-43
2	2	Screw, 10-32 x 1/4"	05305-173-01-00
3	2	Bolt, 1/4-20 x 3/8" Hex	05305-274-20-00
4	2	Washer, SS 1/4-20 ID	05311-174-01-00
5	12	Fastener, 10-32	05340-111-58-10
6	1	Door Handle	05700-003-26-62
7	2	Stop, Door Hinge	05700-003-32-55
8	1	Hinge, Left	05700-003-32-71
9	1	Hinge, Right	05700-003-32-72
10	1	Inner Door	05700-003-33-21
11	1	Baffle, Door	05700-003-33-38
12	2	Hinge Spacer	05700-003-33-42
13	2	Retaining Plate	05700-011-44-37
14	1	Channel, Door Seal	05700-003-55-49
15	6	Screw, 1/4-20 x 1 1/2" Hex	05305-274-23-00
16	1	Gasket, Door L	05330-004-36-05
17	1	Gasket Clamp	05700-004-36-56
18	6	Pop Rivet, 1/8" x 3/8"	05320-003-06-98
19	12	Screw, 10-32 x 1/2" Pan Phillips Head	05305-002-32-37
20	2	Locknut, 10-32 with Nylon Insert	05310-373-02-00
21	1	Bracket, Door Magnet	05700-004-52-68
22	1	Magnet, Door	05930-002-88-42
23	2	Screw, 10-32 x 1/2" Pan Phillips Head	05305-011-44-52

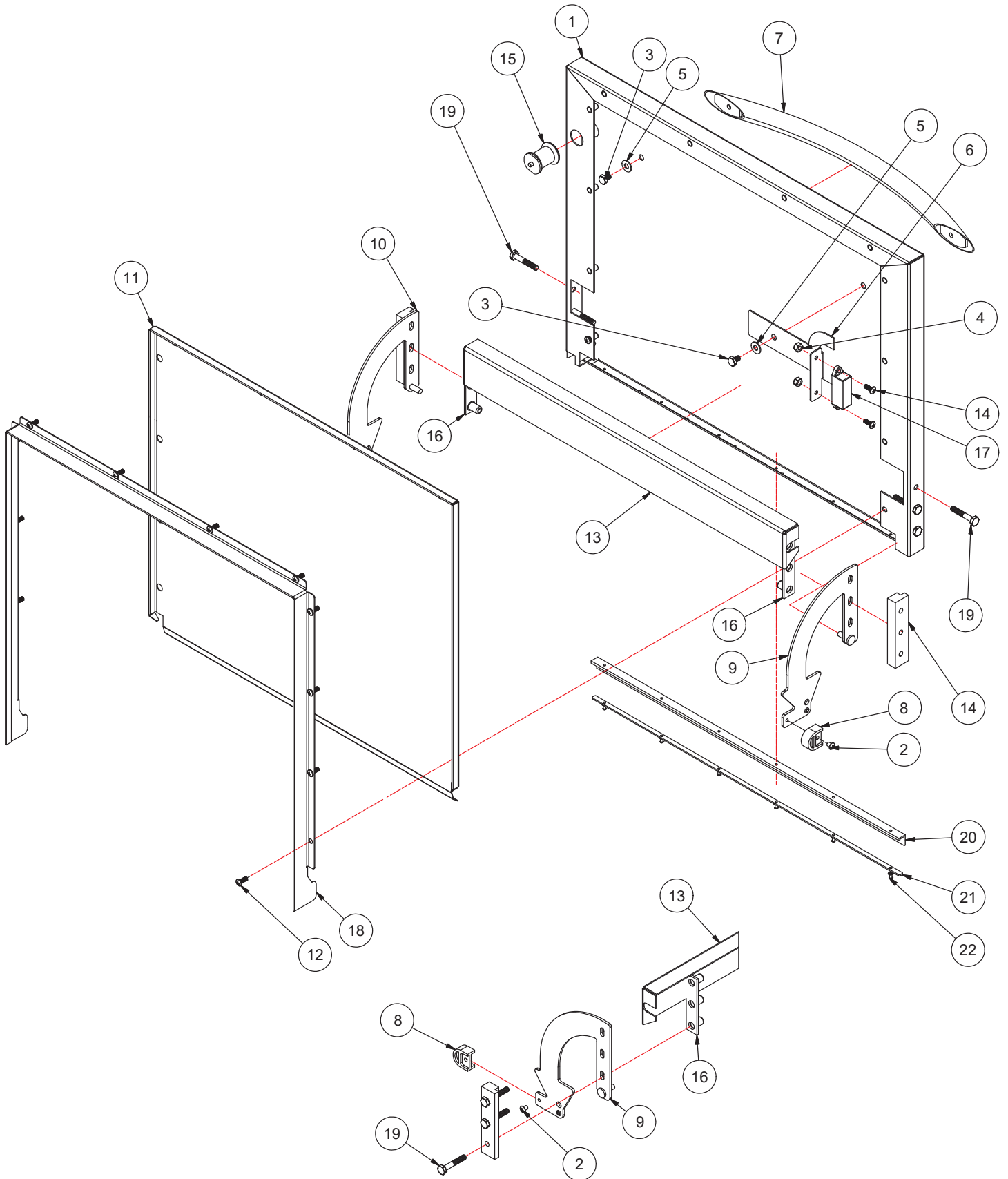

ITEM	QTY	DESCRIPTION	PART NUMBER
1	1	Outer Door Weldment	05700-004-36-55
2	2	Screw, 10-32 x 1/4"	05305-173-01-00
3	2	Bolt, 1/4-20 x 3/8" Hex	05305-274-20-00
4	2	Nut, Lock 10-32 Hex with Nylon Insert	05310-373-02-00
5	2	Washer, SS 1/4-20 ID	05311-174-01-00
6	1	Bracket, Door Magnet	05700-004-52-68
7	1	Door Handle	05700-003-26-62
8	2	Stop, Door Hinge	05700-003-32-55
9	1	Hinge, Left	05700-003-32-71
10	1	Hinge, Right	05700-003-32-72
11	1	Inner Door	05700-003-33-21
12	14	Screw, 10-32 x 1/2" Pan Phillips Head	05305-011-44-52
13	1	Baffle, Door	05700-003-33-38
14	2	Hinge Spacer	05700-003-33-42
15	1	Switch Assembly	05700-003-34-80
16	2	Retaining Plate	05700-011-44-37
17	1	Magnet, Door	05930-002-88-42
18	1	Channel, Door Seal	05700-003-55-49
19	6	Screw, 1/4-20 x 1 1/2" Hex	05305-274-23-00
20	1	Gasket, Door L	05330-004-36-05
21	1	Gasket Clamp	05700-004-36-56
22	6	Pop Rivet, 1/8" x 3/8"	05320-003-06-98

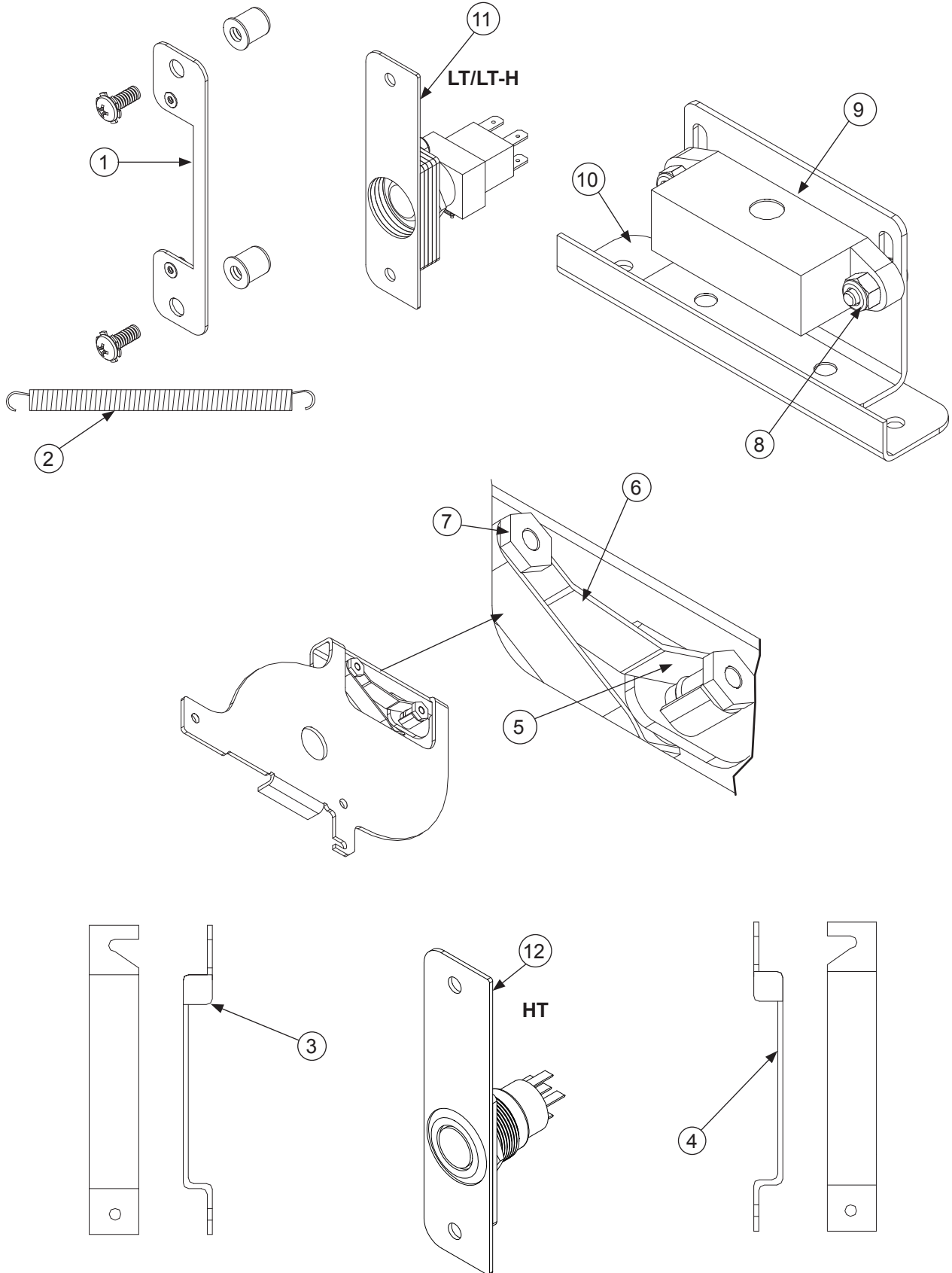

ITEM	QTY	DESCRIPTION	PART NUMBER
1	1	Switch Mounting Plate Assembly	05700-003-33-54
2	1	Door Spring	05700-003-32-85
3	1	Cover, Left Hinge Weldment	05700-004-36-80
4	1	Cover, Right Hinge Weldment	05700-004-36-81
		Hinge Components secured with Locknut, 1/4-20 Hex with Nylon Insert	05310-374-01-00
5	2	O-ring	05330-003-32-34
6	1	Latch Spring	05700-003-32-32
7	2	Latch Nut	05700-003-32-33
8	2	Hardware: Locknut, 6-32 Hex with Nylon Insert	05310-373-03-00
	2	Screw, 6-32 x 1/4" Flat Head	05305-171-01-00
9	1	Door Switch	05930-003-31-44
10	1	Door Switch Bracket	05700-003-31-43
	1	Door Switch & Bracket Assembly	05700-003-32-21
11	1	Complete Switch Mount Assembly (LT/LT-H)	06401-004-47-76
12	1	Complete Switch Mount Assembly (HT)	05700-005-07-45

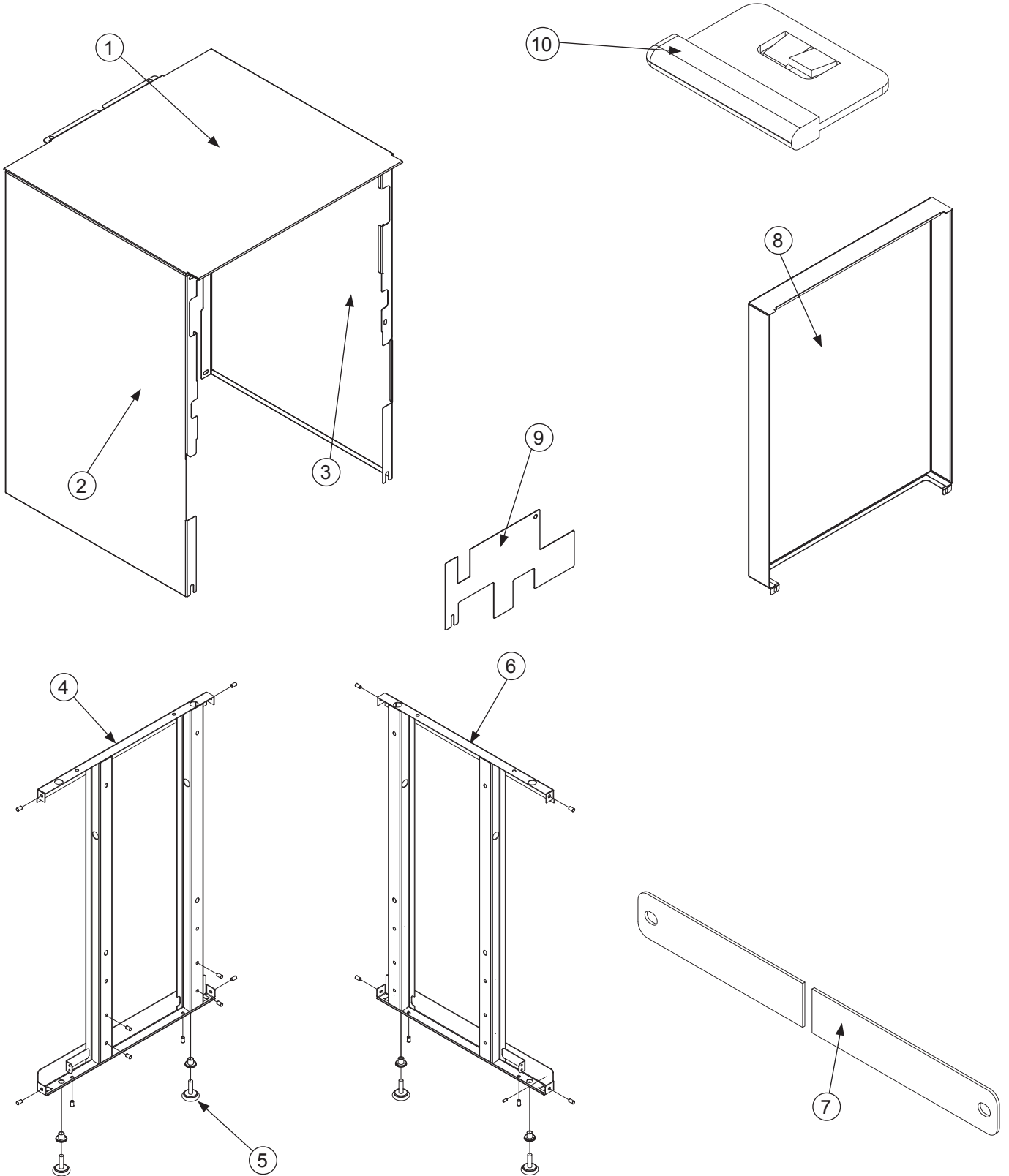

ITEM	QTY	DESCRIPTION	PART NUMBER
1	1	Top Shroud Weldment	05700-003-37-06
2	1	Left Shroud Weldment	05700-003-37-04
3	1	Right Shroud Weldment	05700-004-36-82
4	1	Left Frame Weldment	05700-003-31-91
5	1	Swivel Feet	05340-108-02-00
6	1	Right Frame Weldment	05700-003-31-90
	4	Hardware: Nut, 1/4-20 Serrated Hex	05310-959-03-00
	4	Nut, 5/16-18 Cad Spine	05310-959-03-00
7	2	Bottom Strap	05700-003-92-20
8	1	Optional Back Panel	05700-003-33-55
9	1	Standard Back Panel	05700-004-36-83
10	2	Shroud Plug	05700-003-32-50

Parts are not shown to scale in relation to each other.

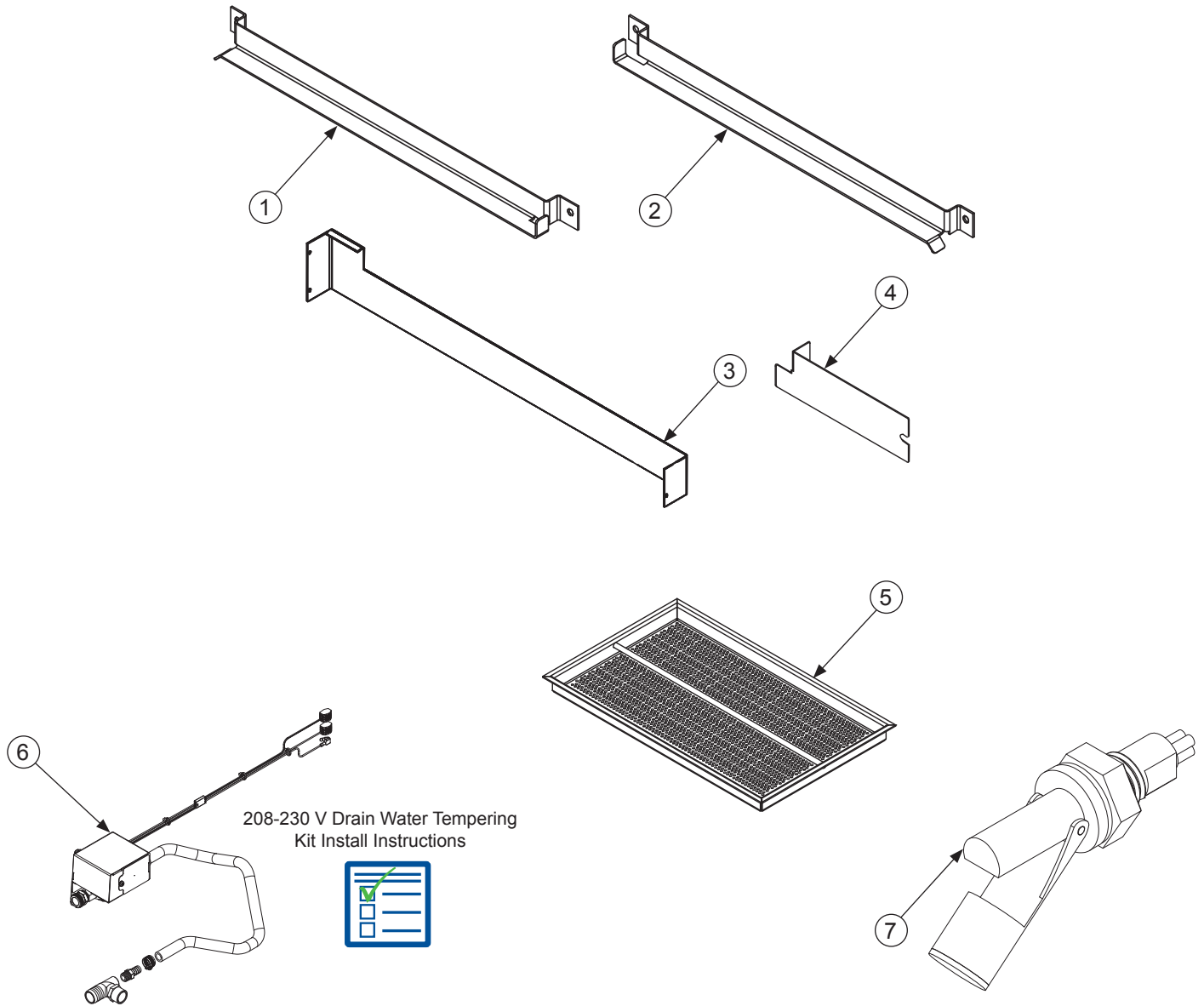

ITEM	QTY	DESCRIPTION	PART NUMBER
		Components secured with Locknut, 1/4-20 SS Hex with Nylon Insert	05310-374-01-00
1	1	Rail, Left Rack	05700-031-37-89
2	1	Rail, Right Rack	05700-031-37-88
3	1	Splash Shield	05700-003-33-51
4	1	Strainer Spacer	05700-002-70-60
		Attaches with: Nut, Nylon Wing, 1/4-20	05310-994-01-00
5	1	Strainer Weldment	05700-031-35-81
6	1	Drain Water Tempering Kit (HT)	06401-004-60-64
7	1	Switch, Horizontal Float (LT-H)	06680-004-05-50

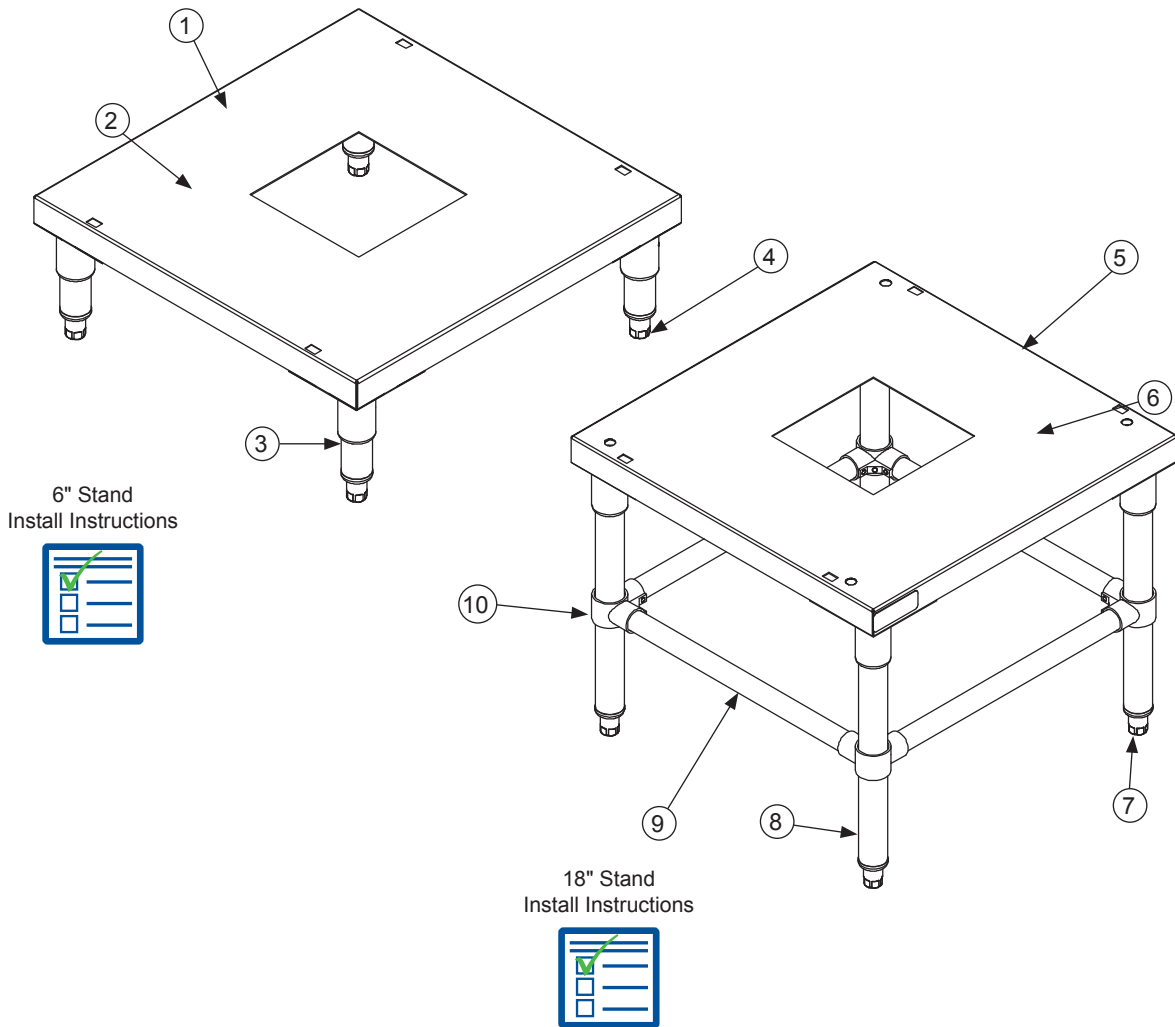

ITEM	QTY	DESCRIPTION	PART NUMBER
1	1	6" Stand Assembly	05700-003-34-24
2	1	Stand	05700-002-88-82
3	4	6" Leg	05700-021-61-10
4	4	Bullet Foot	05340-108-01-03
5	1	18" Stand Assembly	05700-003-34-25
6	1	Stand	05700-002-88-82
7	4	Bullet Foot	05340-108-01-03
8	4	18" Leg	05700-002-89-47
9	4	Cross Brace	05700-003-25-90
10	4	Cross Member Bracket	04730-003-25-89

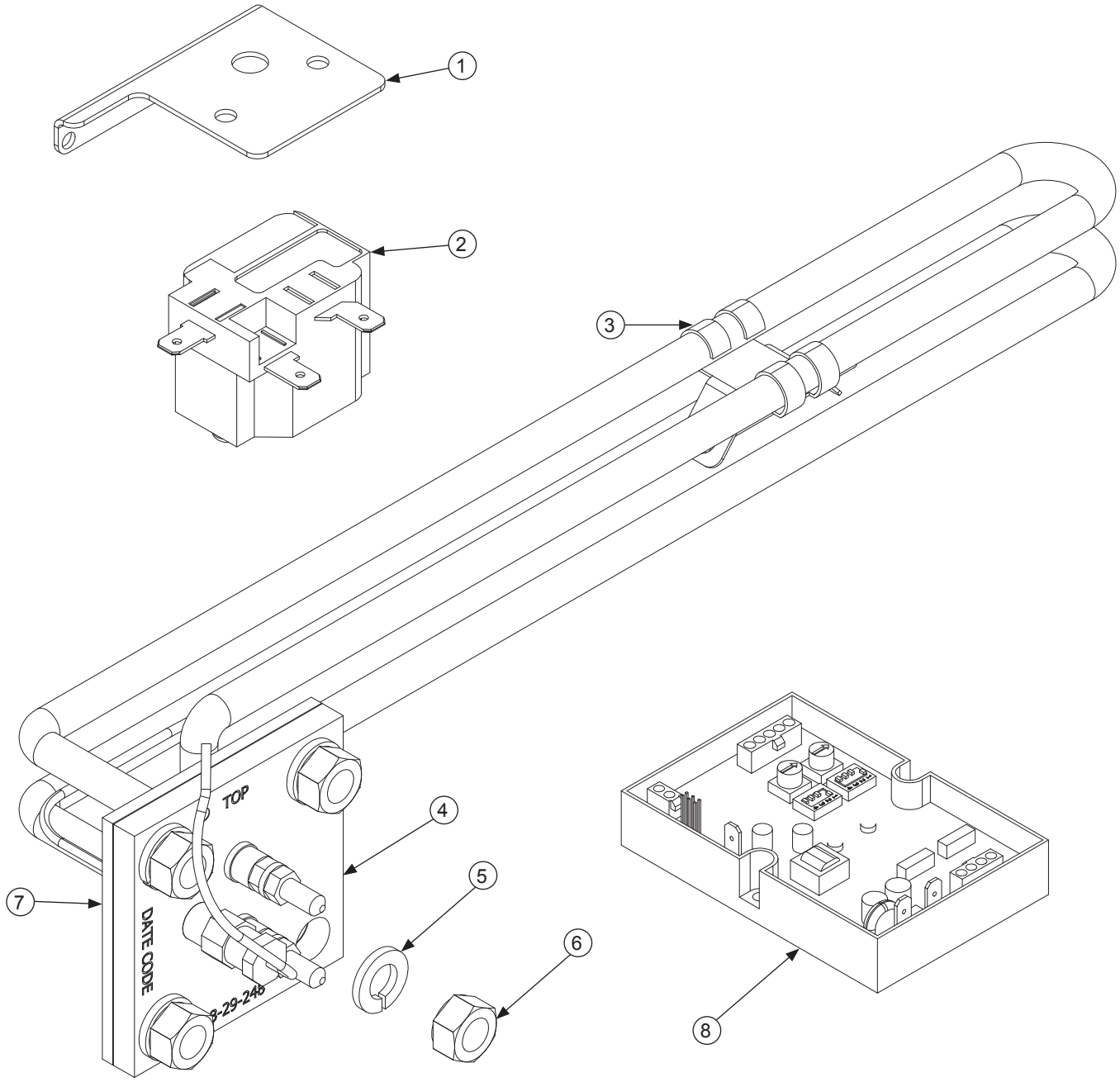

ITEM	QTY	DESCRIPTION	PART NUMBER
1	1	Thermostat Bracket	05700-004-36-37
2	1	High Limit Thermostat	05930-004-33-15
3	1	Probe Bracket	05700-004-38-45
4	1	Wash Heater, 115 V, 1.5 kW	04540-004-33-76
5	4	Lockwasher, Split, 5/16"	05311-275-01-00
6	4	Nut, Hex 5/16-18	05310-275-01-00
7	1	Wash Heater Gasket	05330-011-61-34
8	1	Thermostat, Electric Dual	06685-004-17-27

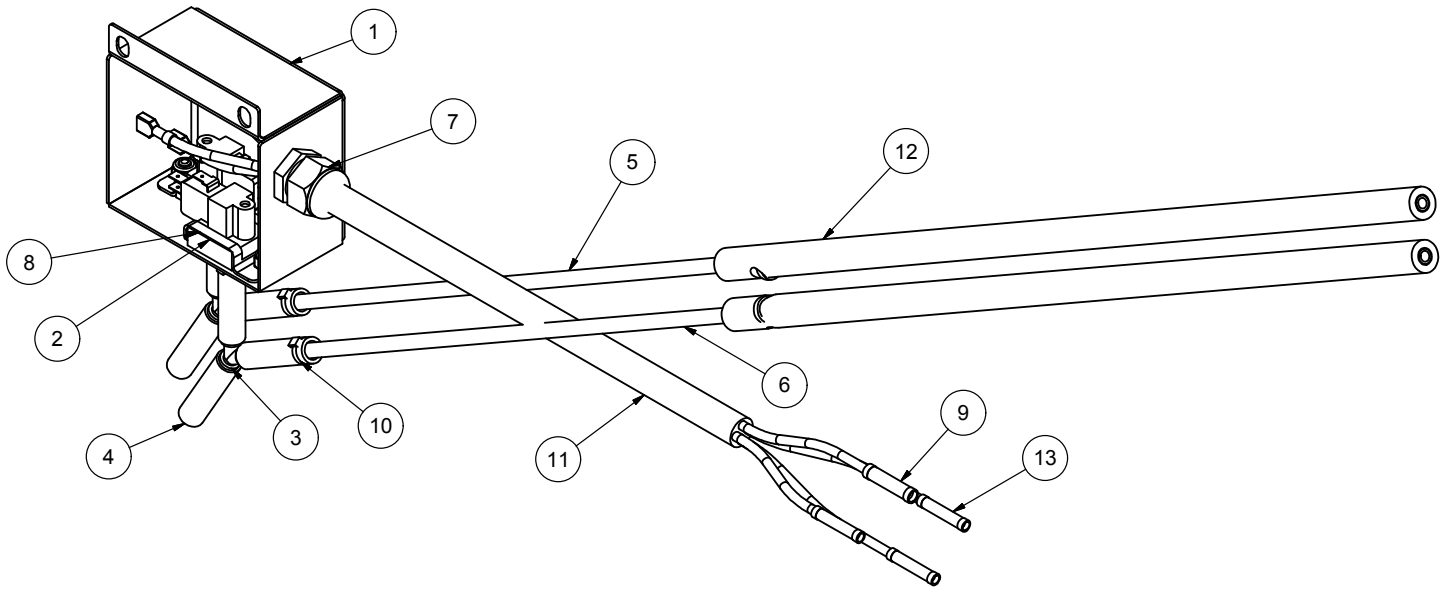

ITEM	QTY	DESCRIPTION	PART NUMBER
		Complete Assembly	05700-003-55-98
1	1	Box, Vacuum Switch	05700-003-55-96
2	2	Switch, Vacuum	06685-003-36-13
3	2	Wye, 1/4" Barbed PVDF	04730-003-36-14
4	6	Tubing, Clear 5/16" ID	04710-003-53-26
5	1	Tube, Red 1/4" OD x 100" Long	05700-003-03-45
6	1	Tube, White 1/4" OD x 100" Long	05700-003-03-45
7	1	Fitting, Liquidtite .231" x .394" Heyco	05700-003-20-67
8	2	Pressure Switch Bracket	05700-003-53-03
9	2	Splice, Blue Butt	05940-200-11-44
10	6	Locknut, 10-24 x 3/8" Phillips Truss	05945-602-01-16
11	14	Cable, 18 GA/5 Con 46"	05700-003-55-97
12	3	Tube Stiffener	05700-002-66-49
13	2	Splice, Red Butt	05940-200-26-00



Back of machine showing use of existing mounting hardware for installation of vacuum switch assembly.

Remove locknut on plumbing support bracket and mount switch box over existing stud. Reinstall bracket and route red and white tubes behind blue hose as shown.

Route gray cable down back and under the tub along inlet plumbing, remove wires from existing pressure switches, and connect to gray cable per instructions below.

Detergent Switch (Red Tube)

1. Connect black wire from gray cable to black/yellow wire from switch.
2. Connect brown wire from gray cable to blue wire from switch.

Sanitizer Switch (White Tube)

1. Connect white wire from gray cable to white/yellow wire from switch.
2. Connect red wire from gray cable to blue wire from switch.



After cutting the existing red and white tube approximately 12" above the gray tube stiffener, insert the cut ends into the clear tubes as shown.

NOTICE

Machines with serial numbers before 23D415452 have a different schematic. Click [here](#) to open earlier manual.

DISHSTAR SCHEMATIC HT wo/UT

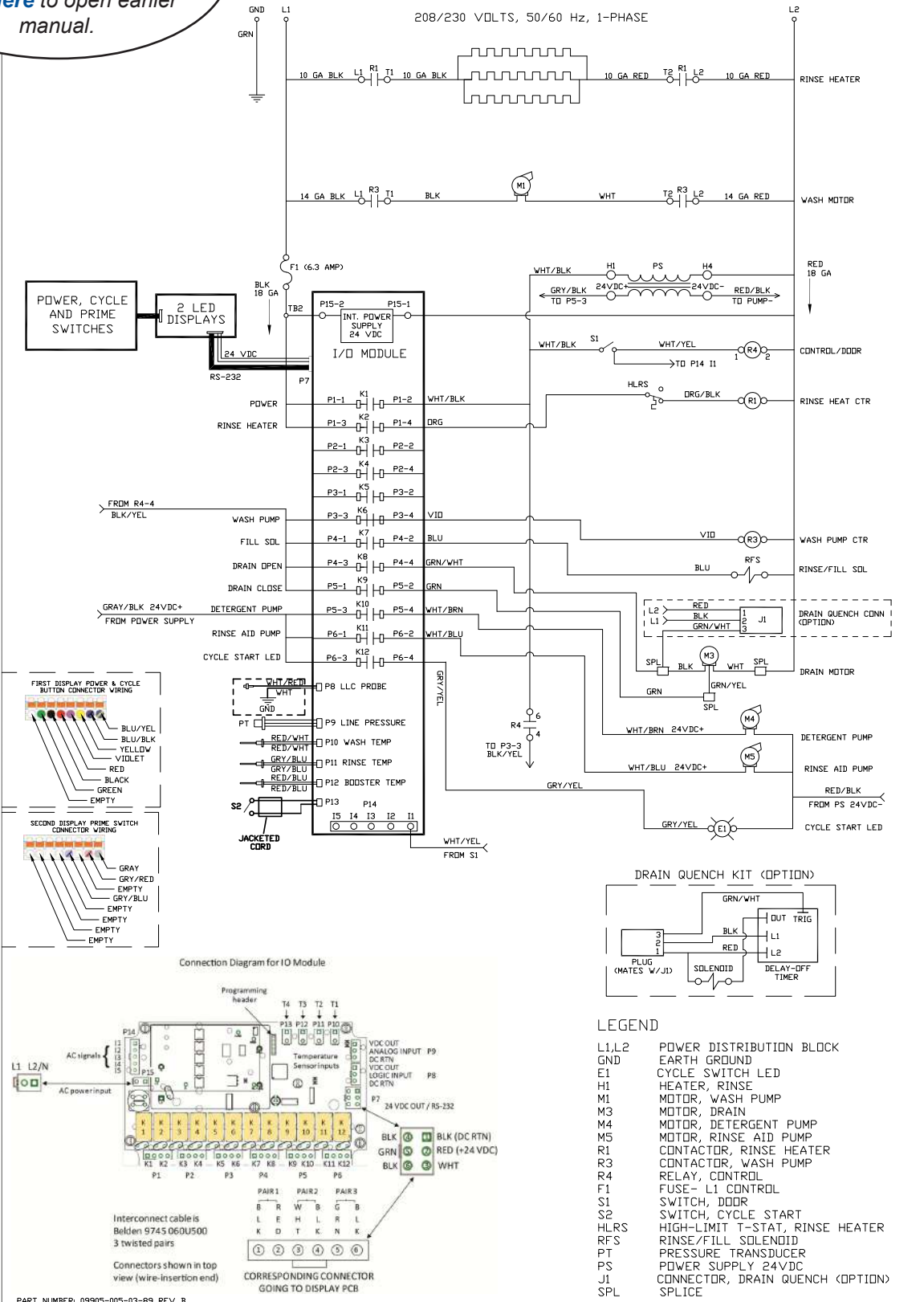

POWER, CYCLE AND PRIME SWITCHES

2 LED DISPLAYS

FIRST DISPLAY POWER & CYCLE BUTTON CONNECTOR WIRING

SECOND DISPLAY PRIME SWITCH CONNECTOR WIRING

Connection Diagram for I/O Module

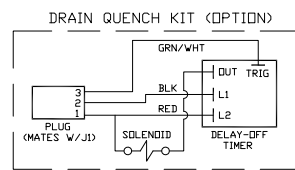
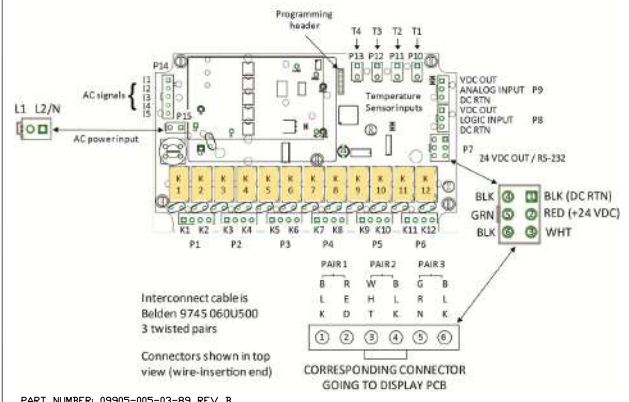

LEGEND

- L1,L2 POWER DISTRIBUTION BLOCK
- GND EARTH GROUND
- E1 CYCLE SWITCH LED
- H1 HEATER, RINSE
- M1 MOTOR, WASH PUMP
- M3 MOTOR, DRAIN
- M4 MOTOR, DETERGENT PUMP
- M5 MOTOR, RINSE AID PUMP
- R1 CONTACTOR, RINSE HEATER
- R3 CONTACTOR, WASH PUMP
- R4 RELAY, CONTROL
- F1 FUSE- L1 CONTROL
- S1 SWITCH, DOOR
- S2 SWITCH, CYCLE START
- HLRS HIGH-LIMIT T-STAT, RINSE HEATER
- RFS RINSE/FILL SOLENOID
- PT PRESSURE TRANSDUCER
- PS POWER SUPPLY 24VDC
- J1 CONNECTOR, DRAIN QUENCH (OPTION)
- SPL SPLICE

**DISHSTAR LT
SCHEMATIC**

(WITH OPTIONAL WASH-TANK HEATER)
115 VOLTS, 50/60 Hz, 1-PHASE

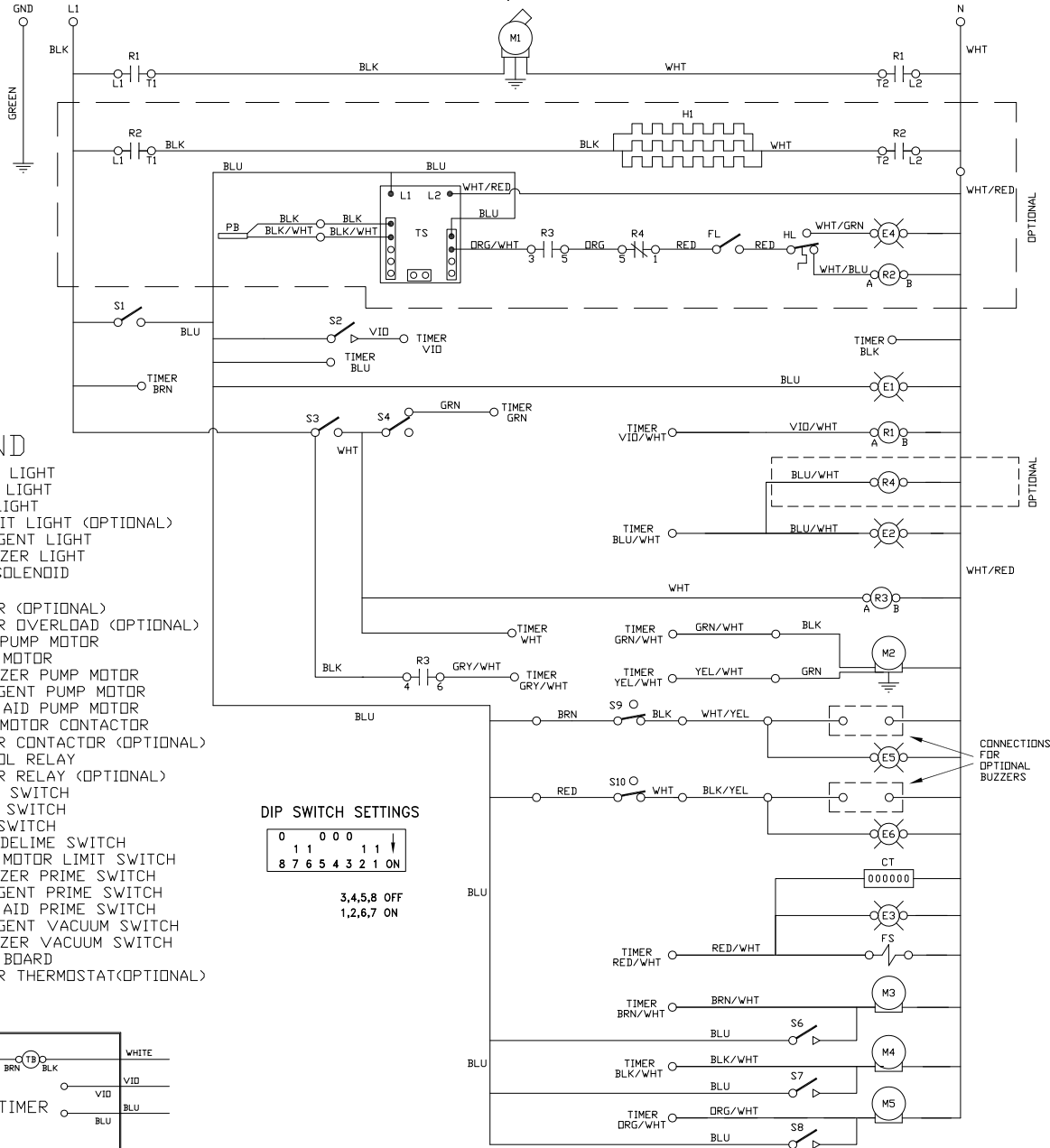

LEGEND

- E1 POWER LIGHT
- E2 CYCLE LIGHT
- E3 FILL LIGHT
- E4 HI LIMIT LIGHT (OPTIONAL)
- E5 DETERGENT LIGHT
- E6 SANITIZER LIGHT
- FS FILL SOLENOID
- FL FLOAT
- H1 HEATER (OPTIONAL)
- HL HEATER OVERLOAD (OPTIONAL)
- M1 WASH PUMP MOTOR
- M2 DRAIN MOTOR
- M3 SANITIZER PUMP MOTOR
- M4 DETERGENT PUMP MOTOR
- M5 RINSE AID PUMP MOTOR
- R1 WASH MOTOR CONTACTOR
- R2 HEATER CONTACTOR (OPTIONAL)
- R3 CONTROL RELAY
- R4 HEATER RELAY (OPTIONAL)
- S1 POWER SWITCH
- S2 CYCLE SWITCH
- S3 DOOR SWITCH
- S4 WASH/DELIME SWITCH
- S5 DRAIN MOTOR LIMIT SWITCH
- S6 SANITIZER PRIME SWITCH
- S7 DETERGENT PRIME SWITCH
- S8 RINSE AID PRIME SWITCH
- S9 DETERGENT VACUUM SWITCH
- S10 SANITIZER VACUUM SWITCH
- TB TIMER BOARD
- TS HEATER THERMOSTAT(OPTIONAL)

DIP SWITCH SETTINGS

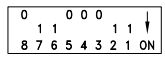

3,4,5,8 OFF
1,2,6,7 ON

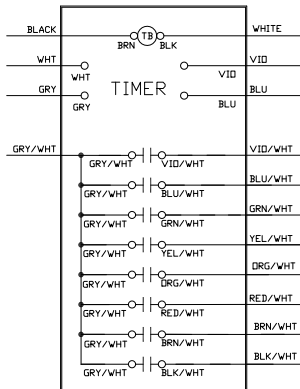

TIMING CHART

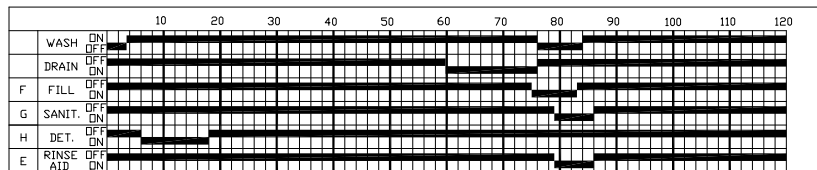

09905-004-38-42 REV B



Jackson WWS, Inc. • 6209 N. US Hwy 25E • Gray, KY 40734 USA
1.888.800.5672 • www.jacksonwws.com