

INSTALLATION/OPERATION & TECHNICAL MANUAL

FOR JACKSON MODELS:

AJ-54CE

AJ-76CE

AJ-90CE

AJ-54CGP

AJ-76CGP

AJ-90CS

AJ-54CS

AJ-76CS

AND ASSOCIATED OPTION PACKAGES INCLUDING:

SIDE LOADER

D226 EXTERNAL STEAM BOOSTER



Jackson

MANUFACTURERS WARRANTY

ONE YEAR LIMITED PARTS & LABOR WARRANTY

ALL NEW JACKSON DISHWASHERS ARE WARRANTED TO THE ORIGINAL PURCHASER TO BE FREE FROM DEFECTS IN MATERIAL OR WORKMANSHIP, UNDER NORMAL USE AND OPERATION FOR A PERIOD OF (1) ONE YEAR FROM THE DATE OF PURCHASE, BUT IN NO EVENT TO EXCEED (18) EIGHTEEN MONTHS FROM THE DATE OF SHIPMENT FROM THE FACTORY.

Jackson MSC agrees under this warranty to repair or replace , at its discretion, any original part which fails under normal use due to faulty material or workmanship during the warranty period, providing the equipment has been unaltered, and has been properly installed, maintained and operated in accordance with the applicable factory instruction manual furnished with the machine and the failure is reported to the authorized service agency within the warranty period. This includes the use of factory specified genuine replacement parts, purchased directly from a Jackson authorized parts distributor or service agency. Use of generic replacement parts may create a hazard and void warranty certification.

The labor to repair or replace such failed part will be paid by Jackson MSC, within the continental United States, Hawaii and Canada, during the warranty period provided a Jackson MSC authorized service agency, or those having prior authorization from the factory, performs the service. Any repair work by persons other than a Jackson MSC authorized service agency is the sole responsibility of the customer. Labor coverage is limited to regular hourly rates, overtime premiums and emergency service charges will not be paid by Jackson MSC.

Accessory components not installed by the factory carry a (1) one year parts warranty only. Accessory components such as table limit switches, pressure regulators, pre rinse units, etc. that are shipped with the unit and installed at the site are included. Labor to repair or replace these components is not covered by Jackson MSC.

This warranty is void if failure is a direct result from shipping, handling, fire, water, accident, misuse, acts of god, attempted repair by unauthorized persons, improper installation, if serial number has been removed or altered, or if unit is used for purpose other than it was originally intended.

TRAVEL LIMITATIONS

Jackson MSC limits warranty travel time to (2) two hours and mileage to (100) one hundred miles. Jackson MSC will not pay for travel time and mileage that exceeds this, or any fees such as those for air or boat travel without prior authorization.

WARRANTY REGISTRATION CARD

The warranty registration card supplied with the machine must be returned to Jackson MSC within 30 days to validate the warranty.

REPLACEMENT PARTS WARRANTY

Jackson replacement parts are warranted for a period of 90 days from the date of installation or 180 days from the date of shipment from the factory, which ever occurs first.

PRODUCT CHANGES AND UPDATES

Jackson MSC reserves the right to make changes in design and specification of any equipment as engineering or necessity requires.

THIS IS THE ENTIRE AND ONLY WARRANTY OF JACKSON MSC. JACKSON'S LIABILITY ON ANY CLAIM OF ANY KIND, INCLUDING NEGLIGENCE, WITH RESPECT TO THE GOODS OR SERVICES COVERED HEREUNDER, SHALL IN NO CASE EXCEED THE PRICE OF THE GOODS OR SERVICES OR PART THEREOF WHICH GIVES RISE TO THE CLAIM.

THERE ARE NO WARRANTIES, EXPRESSED OR IMPLIED, INCLUDING FOR FITNESS OR MERCHANTABILITY, THAT ARE NOT SET FORTH HEREIN, OR THAT EXTEND BEYOND THE DURATION HEREOF. UNDER NO CIRCUMSTANCES WILL JACKSON MSC BE LIABLE FOR ANY LOSS OR DAMAGE, DIRECT OR CONSEQUENTIAL, OR FOR THE DAMAGES IN THE NATURE OF PENALTIES, ARISING OUT OF THE USE OR INABILITY TO USE ANY OF ITS PRODUCTS.

ITEMS NOT COVERED

This warranty does not cover cleaning or deliming of the unit or any component such as, but not limited to, wash arms, rinse arms or strainers at anytime. Nor does it cover adjustments such as, but not limited to timer cams, thermostats or doors, beyond 30 days from the date of installation. In addition, the warranty will only cover the replacement of wear items such as curtains, drain balls, door guides or gaskets during the first 30 days after installation. Also, not covered are conditions caused by the use of incorrect (non-Commercial) grade detergents, incorrect water temperature or pressure, or hard water conditions.



**CALL 1-888-800-5672 TO REGISTER THIS PRODUCT!
FAILURE TO DO SO WILL VOID THE WARRANTY!**

**LLAME AL 1-888-800-5672 PARA REGISTRAR ESTE PRODUCTO!
AL NO HACERLO LA GARANTIA SERA ANULADA!**

**S.V.P. APPELER 1-888-800-5672 POUR ENREGISTRER CE PRODUIT,
LA GARANTIE SERA ANNULEE POUR TOUT PRODUIT NON- ENREGISTREE**



AJ-54CS

AJ = AJ series of rack conveyors

54 = 54" wide machine

76 = 76" wide machine

90 = 90" wide machine

CE = Electrically heated, hot water sanitizing machine

CS = Steam heated, hot water sanitizing machine

CGP = Gas heated, hot water sanitizing machine

Model: _____

Serial No.: _____

Installation Date: _____

Service Rep. Name: _____

Phone No.: _____

Jackson MSC LLC. provides technical support for all of the dishmachines detailed in this manual. We strongly recommend that you refer to this manual before making a call to our technical support staff. Please have this manual with you when you call so that our staff can refer you, if necessary, to the proper page. Technical support is available from 8:00 a.m. to 5:00 p.m. (EST), Monday through Friday. Technical support is not available on holidays. Contact technical support toll free at 1-888-800-5672. Please remember that technical support is available for service personnel only.

TABLE OF CONTENTS

<u>SECTION</u>	<u>DESCRIPTION</u>	<u>PAGE</u>
I.	SPECIFICATION INFORMATION	
	Operating Characteristics	2
	Electrical Requirements	3
	D226 Steam Booster Parameters	4
	AJ-54 Dimensions	5
	AJ-76 (Left to Right) Dimensions	6
	AJ-76 (Right to Left) Dimensions	7
	AJ-90 (Left to Right) Dimensions	8
	AJ-90 (Right to Left) Dimensions	9
	Side Loader (Left to Right) Dimensions	10
	Side Loader (Right to Left) Dimensions	11
	Side Loader (Installed) Dimensions	12
	D226 Steam Booster Dimensions	13
	D226 Steam Booster Plumbing Line Drawings	14
	Typical Electric and Gas Booster Dimensions	15
II.	INSTALLATION & OPERATION INSTRUCTIONS	
	Installation Instructions	17
	Delimiting Operations	20
	Curtain Installation Diagram	21
	Side Loader Installation & Operation Instructions	22
	D226 Steam Booster Installation & Operation Instructions	23
	Gas Conveyor Hose Installation	25
	Dishmachine Operating Instructions	27
	Detergent Control	29
	Photoelectric Limit Switch Installation Instructions	30
	Striker Plate Limit Switch Installation Instructions	31
	Whisker Limit Switch Installation Instructions	32
III.	PREVENTATIVE MAINTENANCE	
	General Maintenance	34
	D226 Maintenance	35
	Drive Motor Gear Reducer Preventative Maintenance	36
IV.	TROUBLESHOOTING SECTION	
	Common Problems	38
	D226 Common Problems	40
V.	SERVICE PROCEDURES	
	Replacing the Pump Gasket & Seal	42
	Rack Rail Stabilizer Kit	45
	Rinse Solenoid Valve Repair Parts Kit	46
	Vacuum Breaker Repair Parts Kit	50
	Drive Motor & Gear Reducer Replacement	52
	Replacing the Wash Heater	57
	Replacing the Conveyor Motor	61
VI.	PARTS SECTION	
	AJ-54 Control Box Assembly	65
	AJ-76/AJ-90 Control Box Assembly	67
	Motor Overload Chart	69
	Heater Assembly	70
	Thermostats	72
	Frame Weldments/Front Dress Panels	72

TABLE OF CONTENTS

VI.	PARTS SECTION (CONTINUED)	
	Prewash Plumbing Assembly	73
	Wash Section Plumbing	74
	External Electric Booster Option Incoming Plumbing	75
	External Electric Booster Option Outlet Plumbing	76
	WPRK Plumbing Option	77
	3/4" Solenoid Valve & 3/4" NPT Vacuum Breaker Repair Parts Kits	78
	Steam Unit Wash Tank Coil Assembly	79
	Steam Inlet/Outlet Plumbing (Left to Right)	80
	Steam Inlet/Outlet Plumbing (Right to Left)	81
	Gas Coil Assembly (CGP Models)	82
	Rinse Booster Tank Assembly (CGP Models)	83
	Recirculating Pump Assembly (CGP Models)	84
	Hose Connections (CGP Models)	85
	Wash/Fill Plumbing Assembly (CGP Models)	86
	Rinse Header Plumbing Assembly (CGP Models)	87
	AJ-54 Series Drain Plumbing Assemblies	88
	AJ-76 Drain Plumbing Assemblies	89
	AJ-90 Drain Plumbing Assemblies	90
	AJ-76 Drain Plumbing Assembly (Left to Right) (CGP Models)	91
	Drain Quench Assembly	92
	Motor Assemblies	93
	Prewash & Wash Pump Weldments	94
	Prewash/Upper Wash Arm Assemblies	95
	Lower Wash Arm Assembly	96
	Curtains/Tub Magnets	97
	Final Rinse Assembly	98
	Drive Assembly	99
	Lubrication Chart for Drive Gear	101
	Door Assemblies	102
	Pawl Bar Miscellaneous Components	103
	AJ-54 Pawl Bar Assembly	104
	AJ-76 Pawl Bar Assemblies	105
	AJ-90 Pawl bar Assemblies	106
	AJ-54 Rack Rail Assembly	107
	AJ-76 Rack Rail Assemblies	108
	AJ-90 Rack Rail Assemblies	109
	Miscellaneous Parts & Weldments	110
	Manifolds/Strainer Support Weldments	111
	Strainers	112
	Float Switch Covers/Scrap Basket Assembly	113
	Vent Cowl Assembly/Vent Scoop Option	114
	Exhaust Fan Control Option/Limit Switch Options	115
	SIDE LOADER SECTION	
	Side Loader Track Assembly/Leg Replacements/Strainer	116
	Side Loader Pawl Bar Assemblies/Pawl Bar Bracket/Magnet	117
	Side Loader Vent Cowl Option	118
	D226 STEAM BOOSTER SECTION	
	Control Box Assembly	119
	Plumbing Assembly	120
	Go*Box Components	122
	Rinse Fill Option	123

TABLE OF CONTENTS

VII.	ELECTRICAL SCHEMATICS	
	AJ-54CE	
	208-230 Volt, 60 Hz, 1 Phase	125
	208-230 Volt, 60 Hz, 3 Phase	126
	460-575-600 Volt, 60 Hz, 3 Phase	127
	AJ-54CS	
	208-230 Volt, 60 Hz, 1 Phase	128
	208-230 Volt, 60 Hz, 3 Phase	129
	460-575-600 Volt, 60 Hz, 3 Phase	130
	AJ-76CE & AJ-90CE	
	208-230 Volt, 60 Hz, 1 Phase	131
	208-230 Volt, 60 Hz, 3 Phase	132
	460-575-600 Volt, 60 Hz, 3 Phase	133
	AJ-76CS & AJ-90CS	
	208-230 Volt, 60 Hz, 1 Phase	134
	208-230 Volt, 60 Hz, 3 Phase	135
	460-575-600 Volt, 60 Hz, 3 Phase	136
	AJ-54CGP	
	208-230 Volt, 60 Hz, 1 Phase	137
	208-230 Volt, 60 Hz, 3 Phase	138
	460 Volt, 60 Hz, 3 Phase	139
	AJ-76CGP	
	208-230 Volt, 60 Hz, 1 Phase	140
	208-230 Volt, 60 Hz, 3 Phase	141
	460 Volt, 60 Hz, 3 Phase	142
	Exhaust Fan Hook-Up Schematics	143
	D226 Steam Booster/Drain Quench/Side Loader Schematics	144
VIII.	MAINTENANCE & REPAIR CENTERS	146

SECTION 1: SPECIFICATION INFORMATION

SECTION 1: SPECIFICATION INFORMATION

OPERATING CHARACTERISTICS

RACKS PER HOUR:

AJ-54-76-90CE/CS/CGP 270

DISHES OR GLASSES PER HOUR:

AJ-54-76-90CE/CS/CGP 6750

PREWASH TANK CAPACITY (GALLONS):

AJ-76CE/CS/CGP 16

AJ-90CE/CS/CGP 16

WASH TANK CAPACITY (GALLONS):

AJ-54-76-90CE/CS/CGP 20.4

PREWASH PUMP CAPACITY (GPM):

AJ-76CE/CS/CGP 120

AJ-90CE/CS/CGP 270

WASH PUMP CAPACITY

GALLONS PER MINUTE (ALL MODELS): 270

VENTING REQUIREMENTS (CFM)(100% CAP.):

INPUT END 200

OUTPUT END 400

TOTAL 600

CONVEYOR SPEED (FPM):

AJ-54-76-90CE/CS/CGP MACHINES 7.5

GALLONS PER RACK:

AJ-54-76-90CE/CS/CGP MACHINES 1.03

WATER TEMPERATURES:

AJ-54-76-90CE/CS/CGP MODELS:

PREWASH (RECOMMENDED) (AJ-76/AJ-90) 110-140°F

WASH (MINIMUM) 160°F

RINSE (MINIMUM) 180°F

FLOW PRESSURE (PSI) 20 ± 5

FLOWRATE (GPM):

AJ-54-76-90CE/CS/CGP 4.7

STEAM COIL TANK HEAT (CS/CSL MODELS ONLY):

STEAM INLET PRESSURE (PSIG) 10-20

STEAM CONNECTION NPT 3/4"

CONSUMPTION @ 15 PSIG (lbs/hr):

AJ-54-76-90CS/CSL 60

MOTOR ELECTRICAL CHARACTERISTICS:

DRIVE MOTOR HP 1/4

WASH MOTOR HP 2

POWER RINSE MOTOR HP 2

PREWASH MOTOR HP:

AJ-76 MODELS 1

AJ-90 MODELS 2

NOTE: Typical Electrical Circuit is based upon (1) 125% of the full amperage load of the machine and (2) typical fixed-trip circuit breaker sizes as listed in the NEC 2002 Edition. Local codes may require more stringent protection than what is displayed here. Always verify with your electrical service contractor that your circuit protection is adequate and meets all applicable national and local codes. These numbers are provided in this manual simply for reference and may change without notice at any given time.

SECTION 1: SPECIFICATION INFORMATION
ELECTRICAL REQUIREMENTS

AJ-54CE MODELS

<u>VOLTS</u>	<u>PH</u>	<u>HZ</u>	<u>TOTAL AMPS</u>	<u>TYPICAL ELECTRICAL CIRCUIT</u>
208	1	60	107 A	150 AMP
230	1	60	98 A	125 AMP
208	3	60	63 A	80 AMP
230	3	60	57 A	80 AMP
460	3	60	29 A	40 AMP
575	3	60	22 A	30 AMP
600	3	60	23 A	30 AMP

AJ-76CE MODELS

<u>VOLTS</u>	<u>PH</u>	<u>HZ</u>	<u>TOTAL AMPS</u>	<u>TYPICAL ELECTRICAL CIRCUIT</u>
208	1	60	113 A	150 AMP
230	1	60	104 A	150 AMP
208	3	60	66 A	90 AMP
230	3	60	61 A	80 AMP
460	3	60	31 A	40 AMP
575	3	60	25 A	35 AMP
600	3	60	26 A	35 AMP

AJ-54CGP MODELS

<u>VOLTS</u>	<u>PH</u>	<u>HZ</u>	<u>TOTAL AMPS</u>	<u>TYPICAL ELECTRICAL CIRCUIT</u>
208	1	60	11 A	15 AMP
230	1	60	11 A	15 AMP
208	3	60	7 A	15 AMP
230	3	60	7 A	15 AMP
460	3	60	4 A	15 AMP

AJ-76CGP MODELS

<u>VOLTS</u>	<u>PH</u>	<u>HZ</u>	<u>TOTAL AMPS</u>	<u>TYPICAL ELECTRICAL CIRCUIT</u>
208	1	60	17 A	25 AMP
230	1	60	17 A	25 AMP
208	3	60	12 A	15 AMP
230	3	60	12 A	15 AMP
460	3	60	6 A	15 AMP

AJ-54CS MODELS

<u>VOLTS</u>	<u>PH</u>	<u>HZ</u>	<u>TOTAL AMPS</u>	<u>TYPICAL ELECTRICAL CIRCUIT</u>
208	1	60	11 A	15 AMP
230	1	60	11 A	15 AMP
208	3	60	7 A	15 AMP
230	3	60	7 A	15 AMP
460	3	60	4 A	15 AMP
575	3	60	4 A	15 AMP
600	3	60	4 A	15 AMP

AJ-76CS MODELS

<u>VOLTS</u>	<u>PH</u>	<u>HZ</u>	<u>TOTAL AMPS</u>	<u>TYPICAL ELECTRICAL CIRCUIT</u>
208	1	60	17 A	25 AMP
230	1	60	17 A	25 AMP
208	3	60	12 A	15 AMP
230	3	60	12 A	15 AMP
460	3	60	6 A	15 AMP
575	3	60	6 A	15 AMP
600	3	60	6 A	15 AMP

SECTION 1: SPECIFICATION INFORMATION

ELECTRICAL REQUIREMENTS (CONTINUED)/D226 STEAM BOOSTER PARAMETERS

AJ-90CE MODELS

<u>VOLTS</u>	<u>PH</u>	<u>HZ</u>	<u>TOTAL AMPS</u>	<u>TYPICAL ELECTRICAL CIRCUIT</u>
208	1	60	115 A	150 AMP
230	1	60	106 A	150 AMP
208	3	60	68 A	90 AMP
230	3	60	63 A	80 AMP
460	3	60	32 A	40 AMP
575	3	60	25 A	35 AMP
600	3	60	26 A	35 AMP

AJ-90CS MODELS

<u>VOLTS</u>	<u>PH</u>	<u>HZ</u>	<u>TOTAL AMPS</u>	<u>TYPICAL ELECTRICAL CIRCUIT</u>
208	1	60	19 A	25 AMP
230	1	60	19 A	25 AMP
208	3	60	14 A	20 AMP
230	3	60	14 A	20 AMP
460	3	60	7 A	15 AMP
575	3	60	6 A	15 AMP
600	3	60	6 A	15 AMP

NOTE: Always refer to the machine data plate for specific electrical and water requirements. The material provided on this page is for reference only and may be subject to change without notice.

D226 STEAM BOOSTER

ELECTRICAL REQUIREMENTS:

VOLTAGE (V)	208-230
FREQUENCY (HZ)	60
PHASE	SINGLE

WATER REQUIREMENTS:

INCOMING WATER TEMPERATURE (MINIMUM)	110°F
FLOW PRESSURE (PSI)	20 ± 5

STEAM REQUIREMENTS:

INCOMING STEAM PRESSURE (PSIG)	15-25
--------------------------------	-------

HEAT EXCHANGER SPECIFICATIONS:*

TUBESIDE WORKING PRESSURE (PSI)	125
SHELLSIDE WORKING PRESSURE (PSI)	125
TUBESIDE HYDROSTATIC TEST PRESSURE (PSI)	250
SHELLSIDE HYDROSTATIC TEST PRESSURE (PSI)	188
MAXIMUM OPERATING TEMPERATURE	295°F
MAXIMUM SHELLSIDE STEAM PRESSURE (PSI)	125

* - Indicates typical design criteria but is subject to change without notice. For more information, contact your authorized Jackson service representative.

WATER OUTLET SAFETY VALVE

SET PRESSURE (PSI):	125
STEAM RELIEF VALVE SET PRESSURE (PSI):	50

SECTION 1: SPECIFICATION INFORMATION

AJ-54 MODEL DIMENSIONS

Left to Right or Right to Left

Legend to Drawing

- A - Machine water inlet 3/4" NPT, 180°F water min. Hi-temp, minimum flow requirements 4.7 GPM, 279 GPH
- B - Drain connection-1 1/2" NPT
- C - Electrical connection (does not include booster heater)
- D - Vent collar 4" wide x 16" long x 7" high- **Optional**
- E - Vent collar - standard both ends
- *F - Incoming low pressure steam connection, 3/4" NPT (gate valve supplied)- **Requires 60 lbs of steam per hour (1.74 BHP)**
- *G - Condensate return connection, 3/4" NPT (return to boiler feeder of open drain)
- * Steam tank heat option only.

Note: All vertical dimensions are +/- 1/2" from floor due to adjustable bullet feet.

Note: Utility connections are identical regardless of direction of flow.

Note: Maximum overall dimension of unit is 30", which includes drain handle and conduit. Minimum door required. - 30" wide x 78" high.

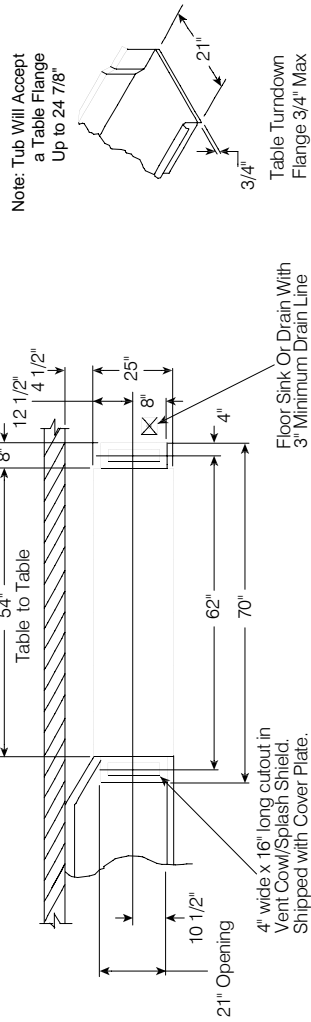

Note: Tub Will Accept a Table Flange Up to 24 7/8"

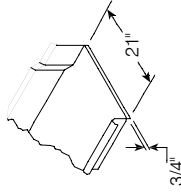

Recommended Table Fabrication

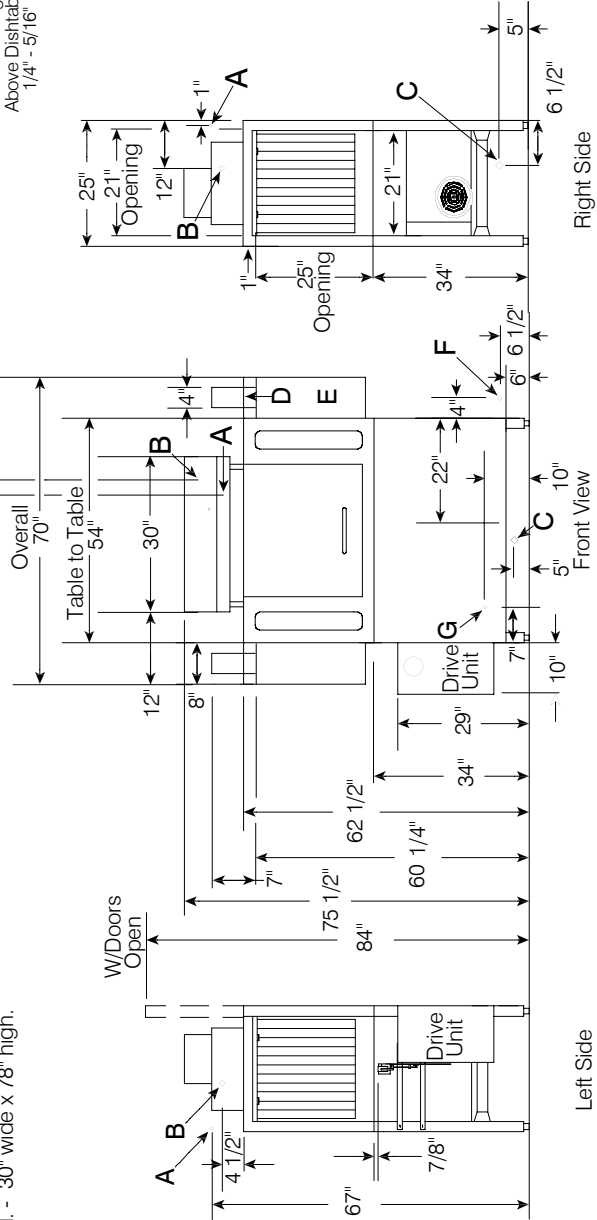
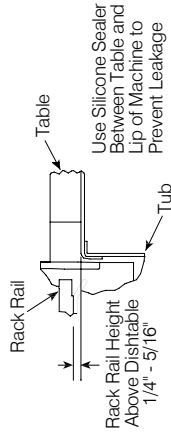

SECTION 1: SPECIFICATION INFORMATION

AJ-76 MODEL (LEFT TO RIGHT) DIMENSIONS

Left to Right Operation Shown

Legend to Drawing

- A - Machine water inlet 3/4" NPT, 180°F Hi-temp, minimum flow requirements 4.7 GPM, 279 GPH
- B - 3/4" NPT prewash water inlet, 140°F water max
- C - Drain connection-1 1/2" NPT
- D - Electrical connection - does not include booster heater
- E - Vent cowl standard
- F - Vent collar 4" wide x 16" long x 7" high - **Optional**
- *G - Incoming low pressure steam connection, 3/4" FPT (gate valve supplied) - **Optional**
- *H - Condensate return connection, 3/4" FPT (return to boiler feeder or open drain)
- J - Cold water thermostat plumbing connection 3/4" NPT - **Optional**

* Steam tank heat option only

Note: All vertical dimensions are +/- 1/2" from floor due to adjustable bullet feet

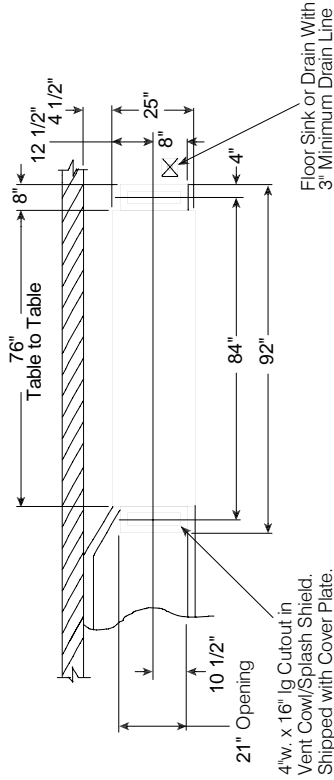

Recommended Table Fabrication

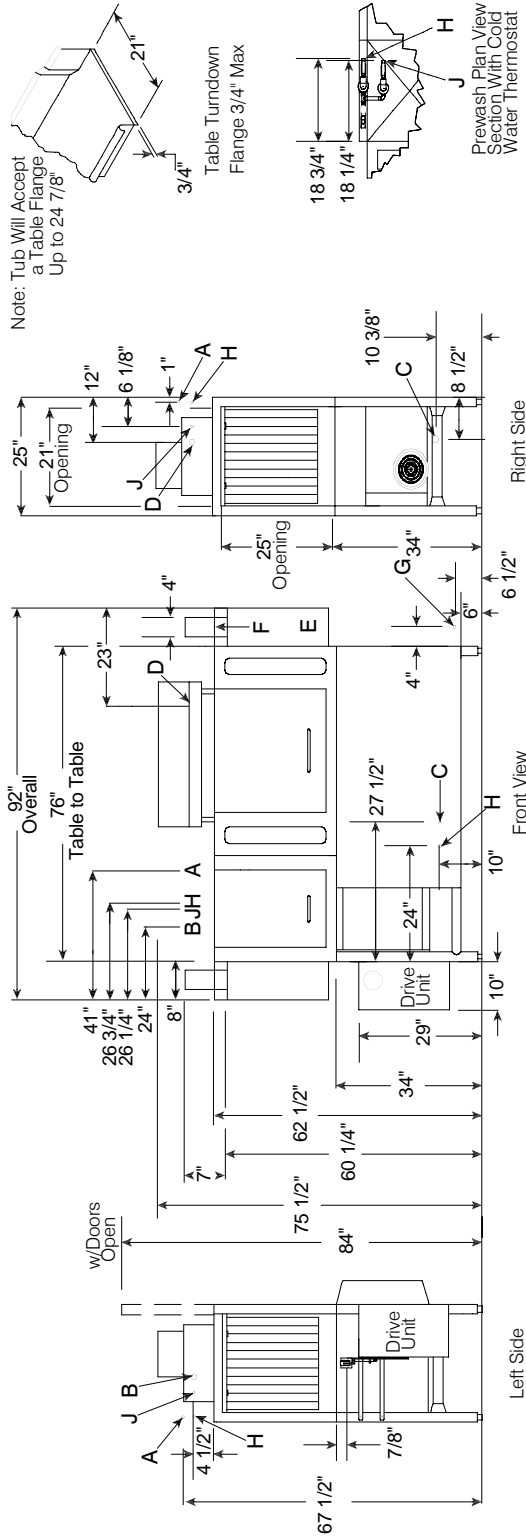
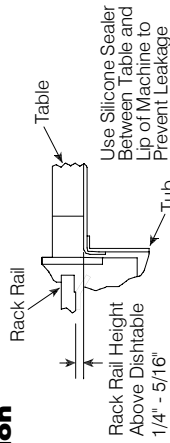

Note: Tub Will Accept a Table Flange Up to 24 7/8"

Table Turndown Flange 3/4" Max

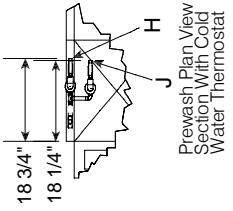

Prewash Plan View Section With Cold Water Thermostat

SECTION 1: SPECIFICATION INFORMATION

AJ-90 MODEL (LEFT TO RIGHT) DIMENSIONS

Left to Right Operation Shown

Legend to Drawing

- A - Machine water inlet, 3/4" NPT, 180°F Hi-temp, minimum flow requirements 4.7 GPM, 279 GPH
 - B - 3/4" NPT prewash water inlet, 140°F water max
 - C - Drain connection-1 1/2" NPT
 - D - Electrical connection - does not include booster heater
 - E - Vent cowi standard
 - F - Vent collar 4" wide x 16" long x 7" high- **Optional**
 - *G - Incoming low pressure steam connection, 3/4" FPT (gate valve supplied)- **Optional**
 - *H - Condensate return connection, 3/4" FPT (return to boiler feeder or open drain)
 - J - Cold water thermostat plumbing connection 3/4" NPT- **Optional**
- * Steam tank heat option only
 Note: All vertical dimensions are +/- 1/2" from floor due to adjustable bullet feet

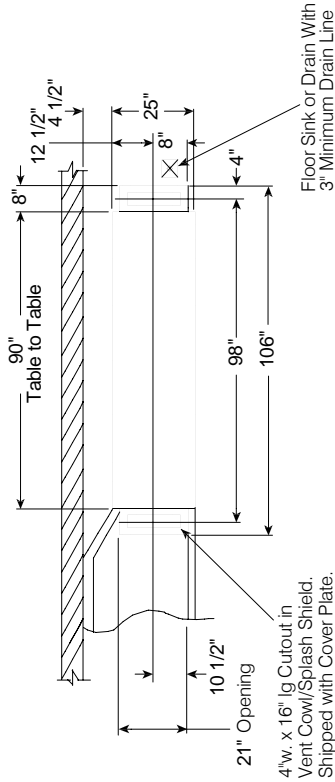

Recommended Table Fabrication

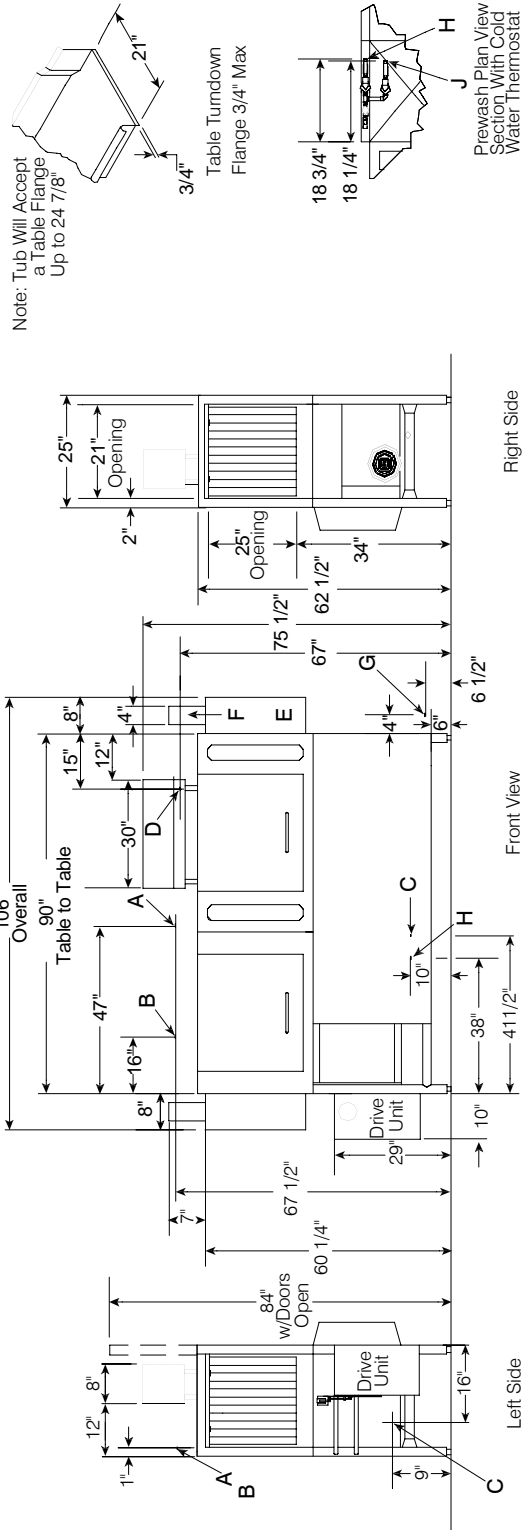
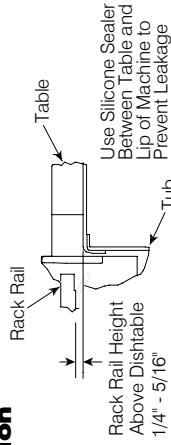

SECTION 1: SPECIFICATION INFORMATION

AJ-90 MODEL (RIGHT TO LEFT) DIMENSIONS

Right to Left Operation Shown

Legend to Drawing

- A - Machine water inlet, 3/4" NPT, 180°F Hi-temp, minimum flow requirements 4.7 GPM, 279 GPH
 - B - 3/4" NPT prewash water inlet, 140°F water max
 - C - Drain connection-1 1/2" NPT
 - D - Electrical connection - does not include booster heater
 - E - Vent cowl standard
 - F - Vent collar 4" wide x 16" long x 7" high- **Optional**
 - *G - Incoming low pressure steam connection, 3/4" FPT (gate valve supplied)- **Optional**
 - *H - Condensate return connection, 3/4" FPT (return to boiler feeder or open drain)
 - J - Cold water thermostat plumbing connection 3/4" NPT- **Optional**
 - * Steam tank heat option only
- Note: All vertical dimensions are +/- 1/2" from floor due to adjustable bullet feet

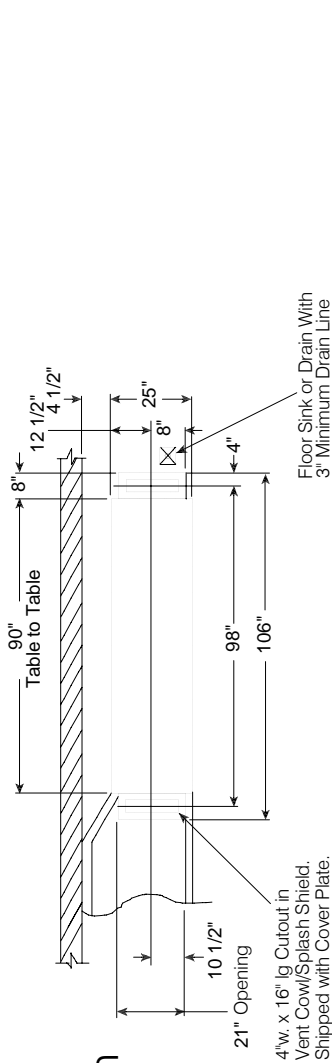

Recommended Table Fabrication

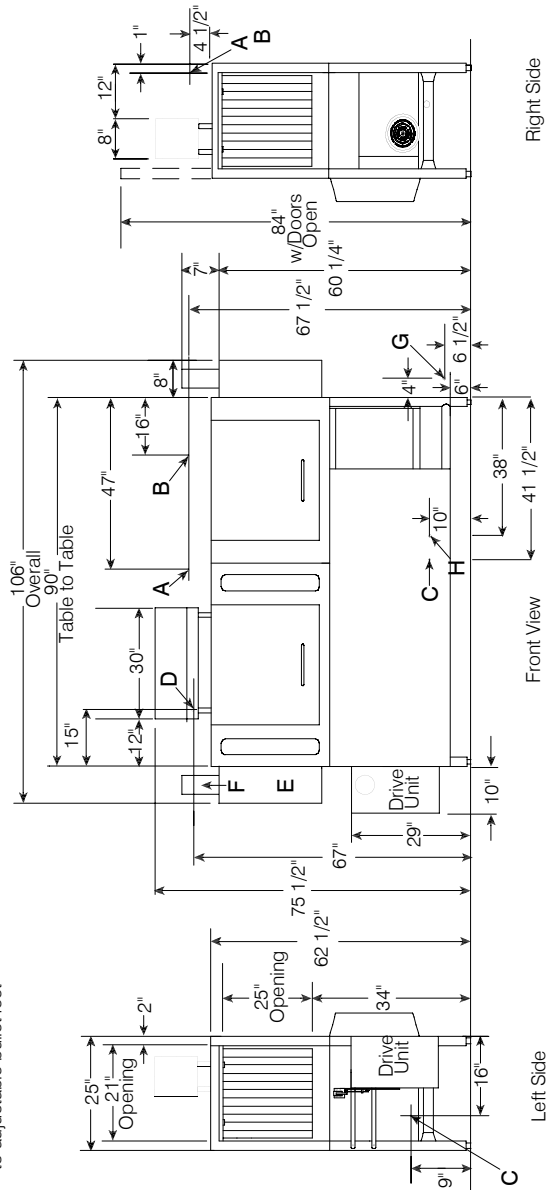
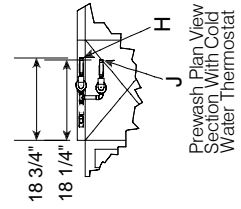
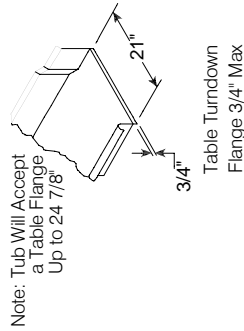
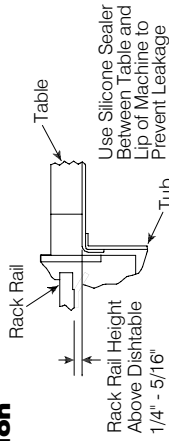

SECTION 1: SPECIFICATION INFORMATION

SIDE LOADER (LEFT TO RIGHT) DIMENSIONS

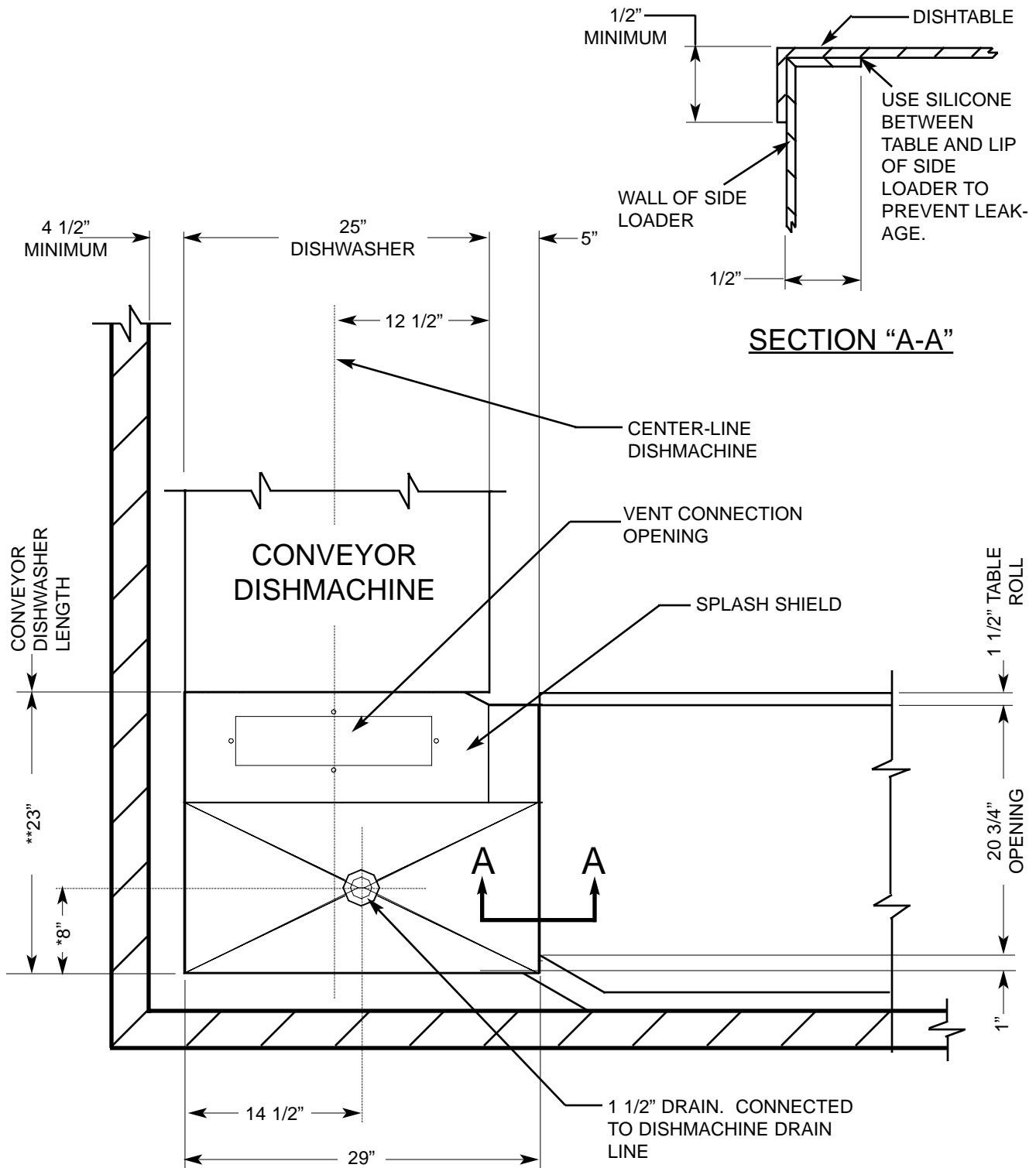

* - 15" for 30" Model
 ** - 30" for 30" Model

SECTION 1: SPECIFICATION INFORMATION

SIDE LOADER (RIGHT TO LEFT) DIMENSIONS

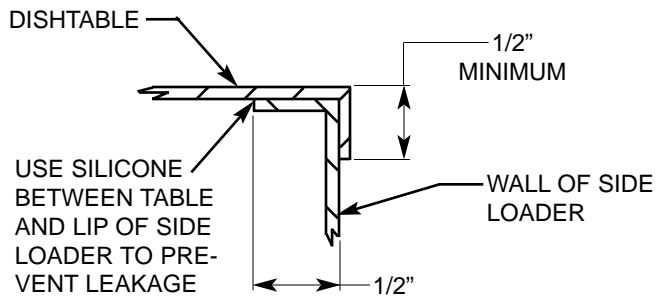

SECTION "A-A"

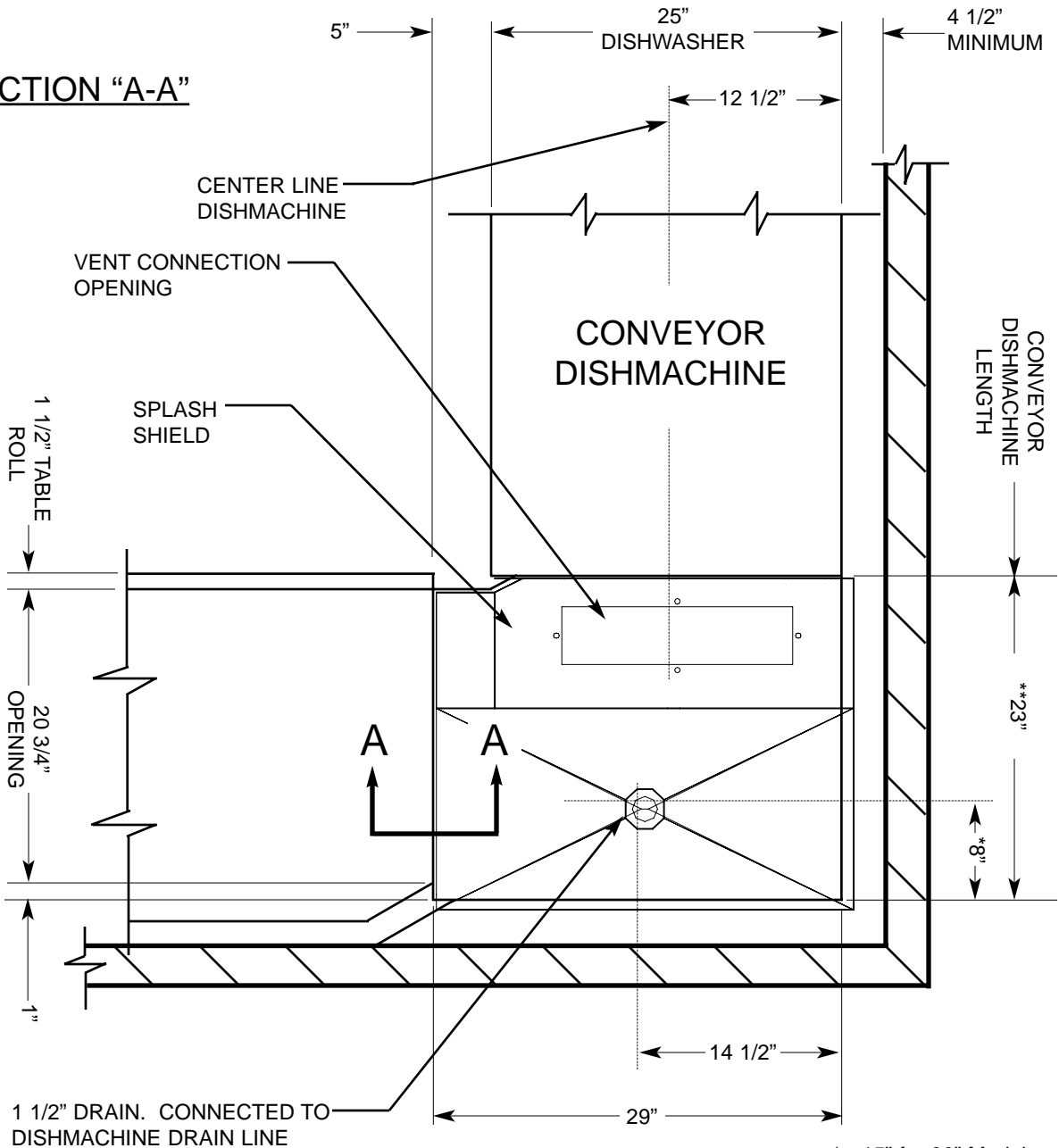

* - 15" for 30" Model
 ** - 30" for 30" Model

SECTION 1: SPECIFICATION INFORMATION

SIDE LOADER INSTALLATION DIMENSIONS

23" SIDE LOADER DIMENSIONS

<u>MODEL</u>	<u>DIMENSIONS</u>
AJ-54	85"
AJ-76	107"
AJ-90	121"

30" SIDE LOADER DIMENSIONS

<u>MODEL</u>	<u>DIMENSIONS</u>
AJ-54	92"
AJ-76	114"
AJ-90	128"

NOTE: ALL DIMENSIONS ARE TYPICAL.

(Left to Right installation shown for reference.)

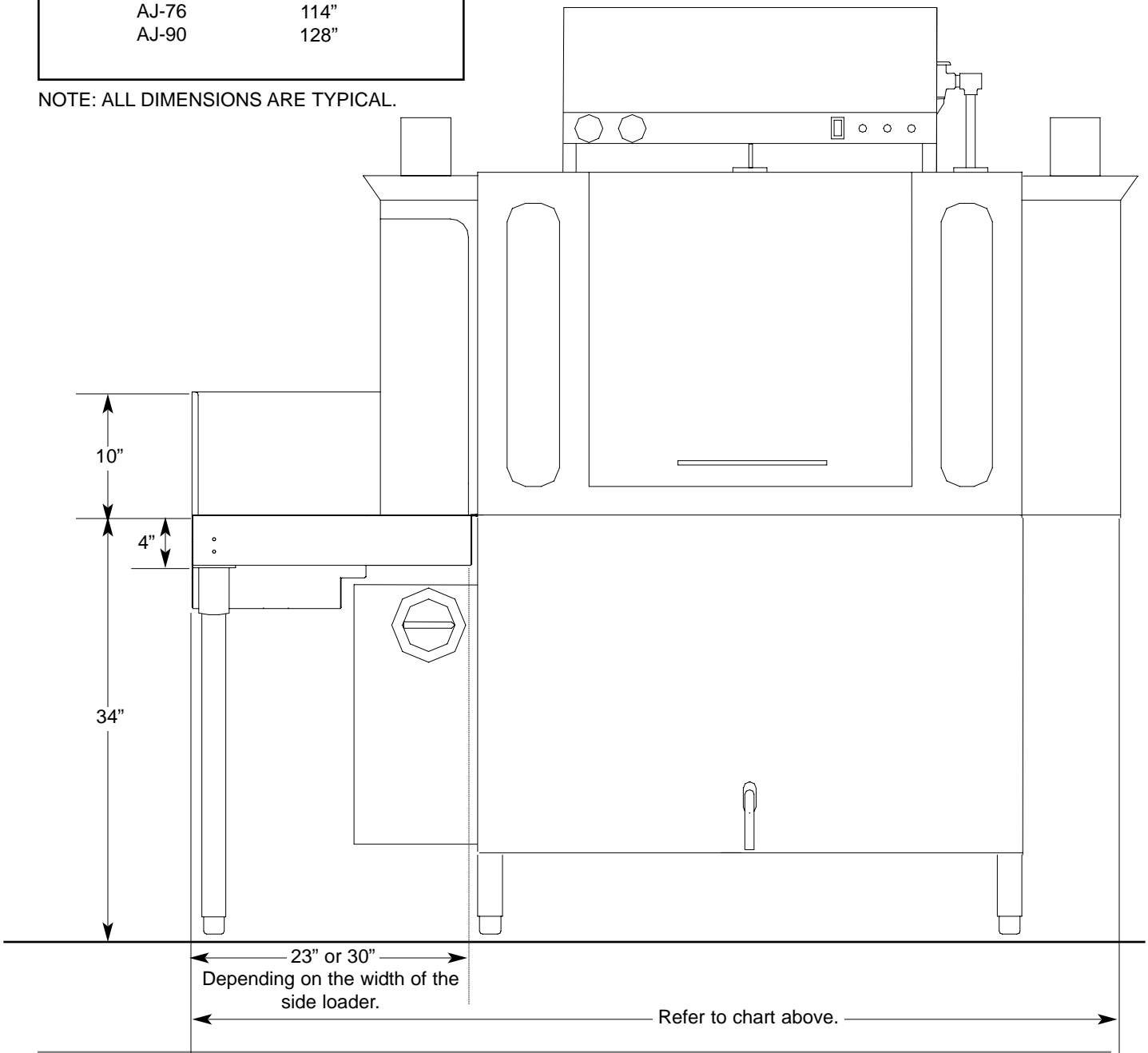

SECTION 1: SPECIFICATION INFORMATION

D226 STEAM BOOSTER DIMENSIONS

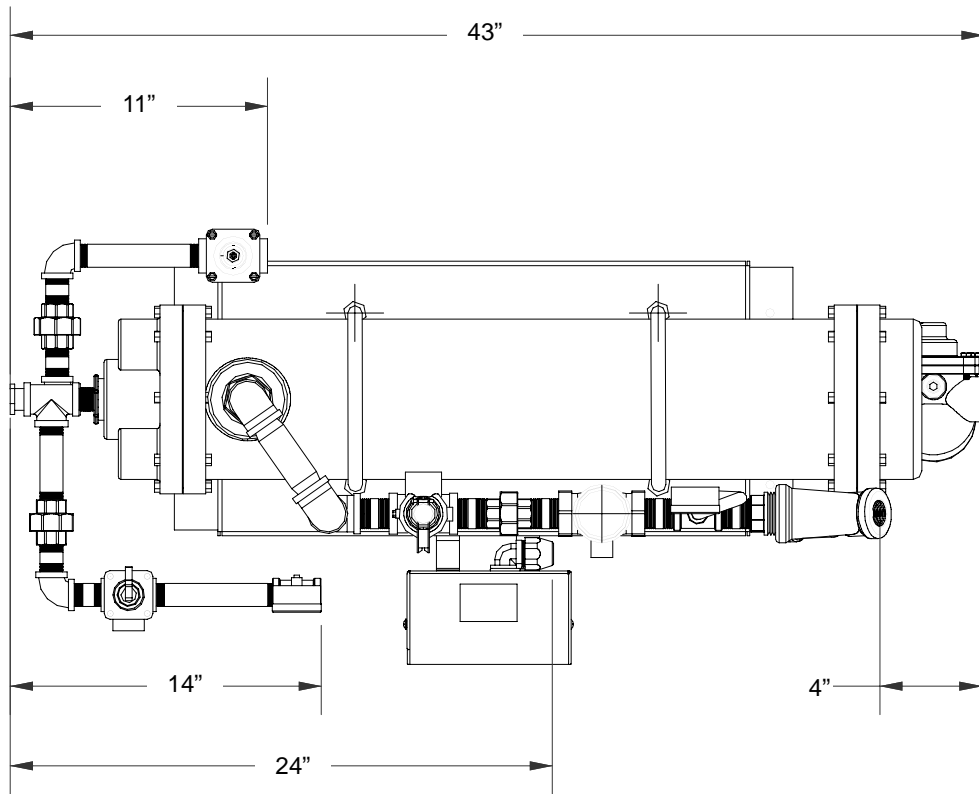

NOTE: All dimensions are in inches and are for reference only.

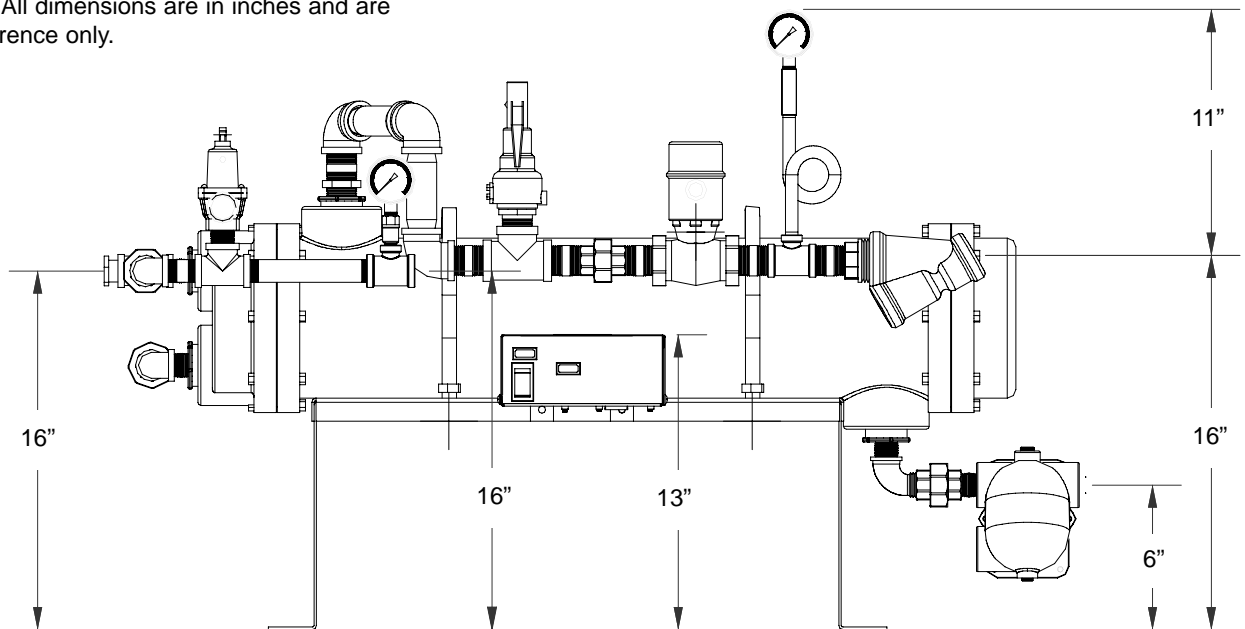

SECTION 1: SPECIFICATION INFORMATION
D226 STEAM BOOSTER PLUMBING LINE DRAWINGS

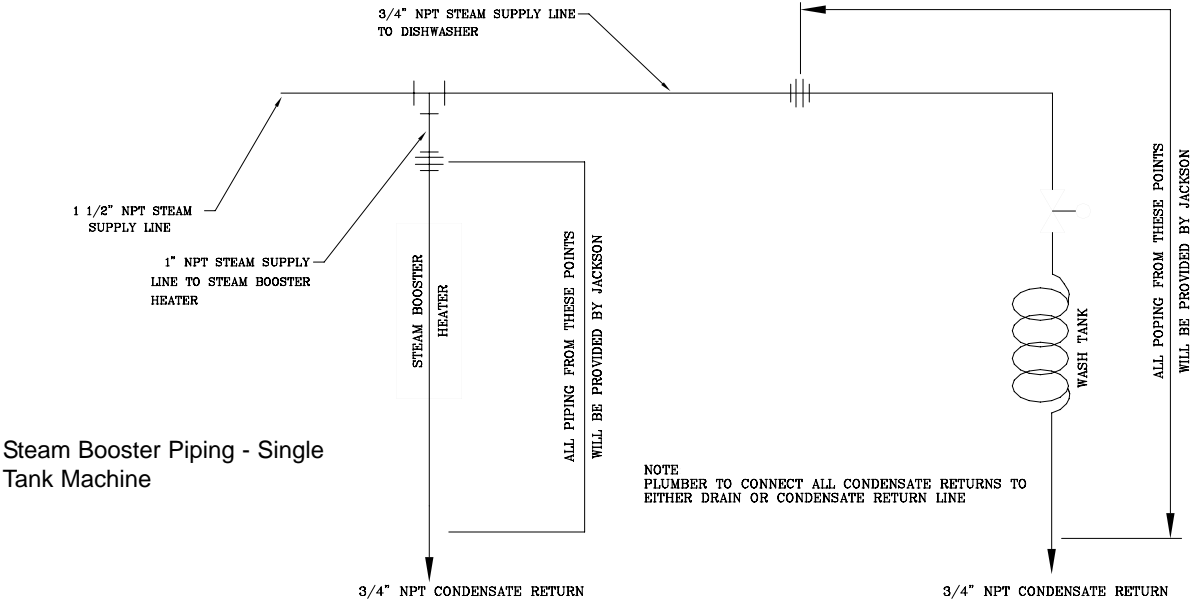

Steam Booster Piping - Single Tank Machine

SECTION 1: SPECIFICATION INFORMATION

TYPICAL ELECTRIC AND GAS BOOSTER DIMENSIONS

Electric Booster Dimensions (Typical)

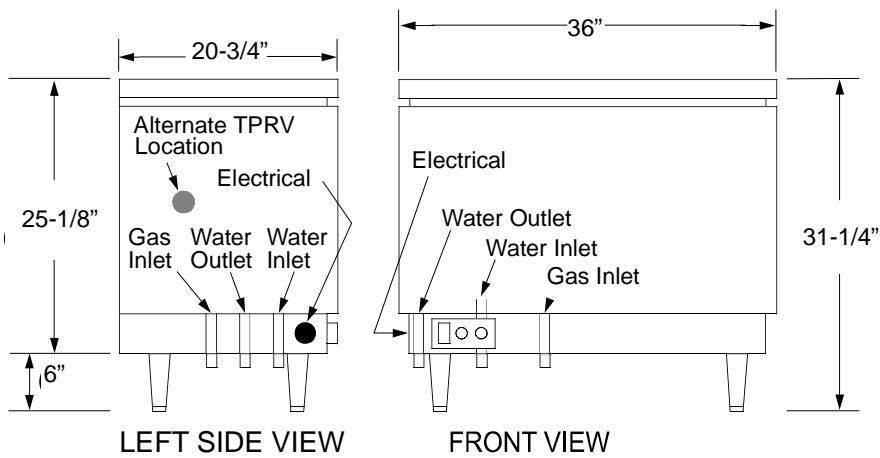
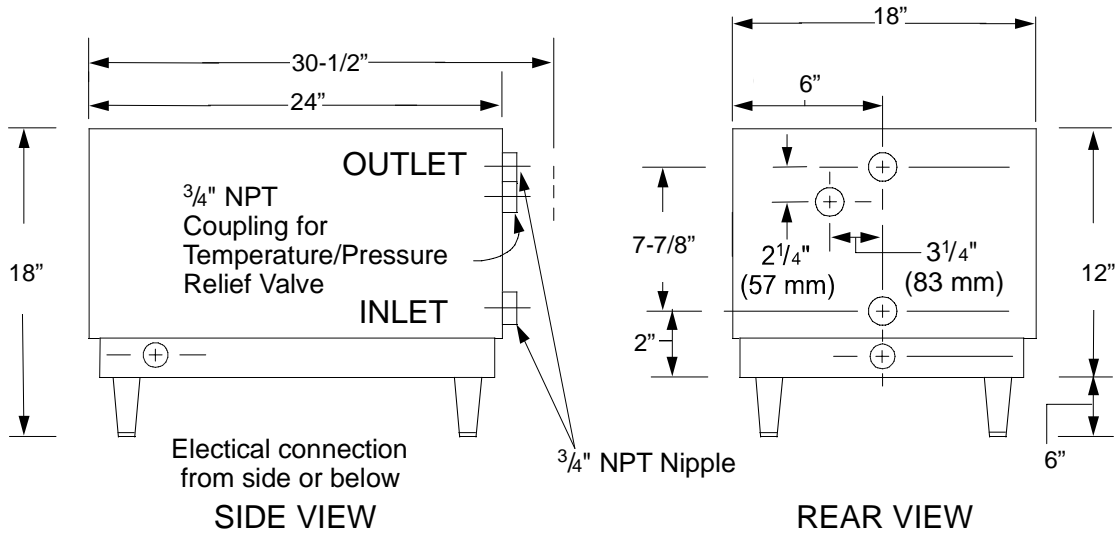

Gas Booster Dimensions (Typical)

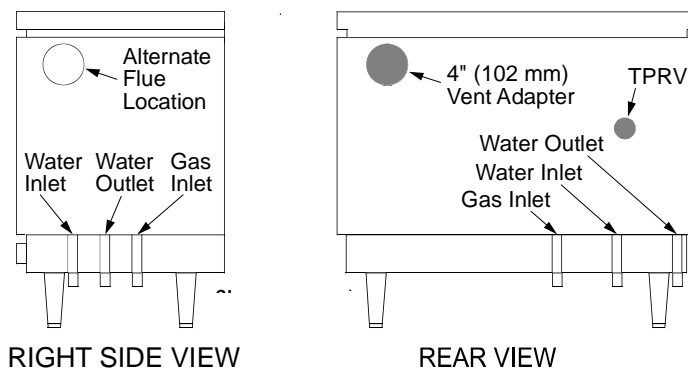

**SECTION 2:
INSTALLATION/OPERATION
INSTRUCTIONS**

SECTION 2: INSTALLATION/OPERATION INSTRUCTIONS

INSTALLATION INSTRUCTIONS

NOTE: THE INSTRUCTIONS PROVIDED HEREIN, UNLESS OTHERWISE SPECIFIED ARE FOR THE DISHMACHINES ONLY. THERE ARE SEPARATE DIRECTIONS FOR THE GAS BOOSTER.

VISUAL INSPECTION: Before installing the unit, check the container and machine for damage. A damaged container is an indicator that there may be some damage to the machine. If there is damage to both the container and machine, do not throw away the container. The dishmachine has been inspected and packed at the factory and is expected to arrive to you in new, undamaged condition. However, rough handling by carriers or others may result in damage to the unit while in transit. If such a situation occurs, do not return the unit to Jackson; instead, contact the carrier and ask them to send a representative to the site to inspect the damage to the unit and to complete an inspection report. You must contact the carrier within 48 hours of receiving the machine. Also, contact the dealer through which you purchased the unit.

UNPACKING THE DISHMACHINE: The machine should be unboxed and removed from shipping pallet prior to being installed. Open the front door and remove all of the packing materials. Once unpacked, ensure that there are no missing parts from the machine. This may not be obvious at first. If it is discovered that an item is missing, contact Jackson immediately.

LEVEL THE DISHMACHINE: The dishmachine is designed to operate while being level. This is important to prevent any damage to the machine during operation and to ensure the best results when washing ware. The unit comes with adjustable bullet feet, which can be turned using a pair of channel locks or by hand if the unit can be raised safely. Ensure that the unit is level from side to side and from front to back before making any connections. You will be able to adjust the overall height of the unit by turning the bullet feet from between 75-1/2" to 76-1/2".

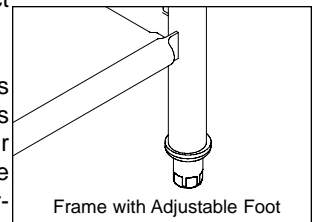

PLUMBING THE DISHMACHINE: All plumbing connections must comply with all applicable local, state, and national plumbing codes. The plumber is responsible for ensuring that the incoming water line is thoroughly flushed prior to connecting it to any component of the dishmachine. It is necessary to remove all foreign debris from the water line that may potentially get trapped in the valves or cause an obstruction. Any valves that are fouled as a result of foreign matter left in the water line, and any expenses resulting from this fouling, are not the responsibility of the manufacturer.

Water hardness should be a maximum of 6 grains per gallon. Harder water should be treated prior to using the machine. Iron in the water supply can cause staining. A filter designed to remove iron from the supply water is highly recommended for supplies in excess of 0.1 ppm (parts per million).

CONNECTING THE DRAIN LINE: The drain for the models covered in this manual are gravity discharge drains. All piping from the machine to the drain must be a minimum 1 1/2" NPT and should not be reduced. There must also be an air gap between the machine drain line and the floor sink or drain. If a grease trap is required by code, it should have a flow capacity of 30 gallons per minute.

WATER SUPPLY CONNECTION: Ensure that you have read the section entitled "PLUMBING THE DISHMACHINE" above before proceeding. The supply water temperature must meet the minimum requirements listed on the machine data plate. Install the water supply line (3/4" pipe size minimum) to the dishmachine line strainer. It is recommended that a water shut-off valve be installed in the water line between the main supply and the machine to allow access for service. The water supply line is to be capable of 25 PSI "flow" pressure at the recommended temperature indicated on the data plate.

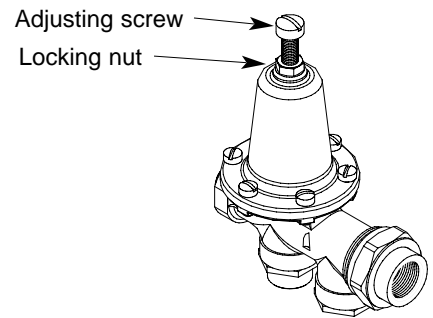

If the water level is too low or too high, check the incoming water pressure. It should be 20 ± 5 PSI. Too high of pressure results in too much water; too low of pressure results in too little water. To adjust the regulator, loosen the nut at the top, this will allow you to screw or unscrew the adjustment. With a screwdriver, turn the adjuster clockwise to increase pressure or counter clockwise to decrease it.

Do not confuse static pressure with flow pressure. Static pressure is the line pressure in a "no flow" condition (all valves and services are closed). Flow pressure is the pressure in the fill line when the fill valve is opened during the cycle.

SECTION 2: INSTALLATION/OPERATION INSTRUCTIONS

INSTALLATION INSTRUCTIONS (CONTINUED)

It is also recommended that a shock absorber (not supplied) be installed in the incoming water line. This prevents line hammer (hydraulic shock), induced by the solenoid valve as it operates, from causing damage to the equipment.

STEAM LINE CONNECTIONS: Some machines covered in this manual are designed to use low pressure steam as a source of heat for wash tank water. The machines come with lines by which outside source steam needs to be connected. Connect all incoming steam lines in accordance with the steam booster manufacturer's instructions. Ensure that all applicable codes and regulations are adhered to. See machine data plate for information concerning steam flow pressure.

GAS CONNECTIONS: Some machines covered in this manual are designed to use gas as an outside source of heat for wash tank water. The machines come with connections by which an outside source needs to be connected. Connect all incoming gas lines in accordance with the gas booster manufacturer's instructions. Ensure that all applicable codes and regulations are adhered to.

PLUMBING CHECK: Slowly turn on the water supply to the machine after the incoming fill line and the drain line have been installed. Check for any leaks and repair as required. All leaks must be repaired prior to placing the machine in operation.

ELECTRICAL POWER CONNECTION: Electrical and grounding connections must comply with the applicable portions of the National Electrical Code ANSI/NFPA 70 (latest edition) and/or other electrical codes.

Disconnect electrical power supply and place a tag at the disconnect switch to indicate that you are working on the circuit.

The dishmachine data plate is located on the right side and to the front of the machine. Refer to the data plate for machine operating requirements, machine voltage, total amperage load and serial number.

To install the incoming power lines, open the control box. Install conduit into the pre-punched holes in the back of the control box. Route power wires and connect to power block and grounding lug. Install the service wires (L1, L2, and L3 (3 phase only)) to the appropriate terminals as they are marked on the terminal block. Install the grounding wire into the lug provided. Tighten the connections. It is recommended that "DE-OX" or another similar anti-oxidation agent be used on all power connections.

VOLTAGE CHECK: Ensure that the power switch is in the OFF position and apply power to the dishmachine. Check the incoming power at the terminal block and ensure it corresponds to the voltage listed on the data plate. If not, contact a qualified service agency to examine the problem. Do not run the dishmachine if the voltage is too high or too low. Shut off the service breaker and mark it as being for the dishmachine. Advise all proper personnel of any problems and of the location of the service breaker. Replace the control box cover and tighten down the screws.

VENTILATION OF DISHMACHINE: The dishmachine should be located with provisions for venting into an adequate exhaust hood or ventilation system. This is essential to permit efficient removal of the condensation exhaust. Ensure that the exhaust system is acceptable in accordance with all applicable codes and standards.

NOTE: Any damage that is caused by steam or moisture due to improper ventilation is NOT covered under the warranty.

This units covered in this manual have the following exhaust requirements:

Load End:	200 CFM
Unload End:	400 CFM

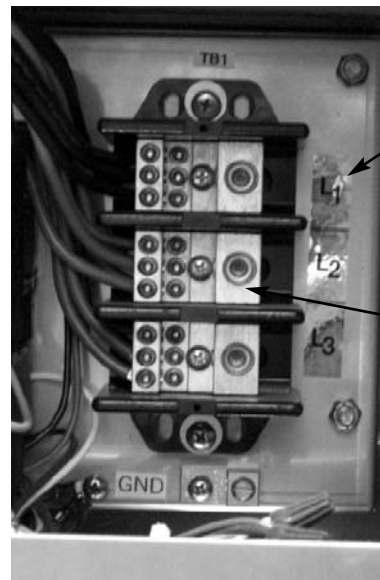

Decal showing
"L1", "L2", & "L3"
(3 phase models
only).

Terminal Block

Incoming Power Connection

SECTION 2: INSTALLATION/OPERATION INSTRUCTIONS

INSTALLATION INSTRUCTIONS (CONTINUED)

The exhaust system must be sized to handle this volume for the dishmachine to operate as it was designed to.

ELECTRIC HEAT: The thermostats for the machines covered in this manual are factory set. They should not be adjusted except by an authorized service agent.

CHEMICAL FEEDER EQUIPMENT: Detergent may be introduced into the unit through the removal of the bulkhead plug in the rear of the tub and replacing it with the third party detergent injection fitting. Remove the bulkhead plug in the side of the tub to install the detergent concentration probe.

For more information concerning detergent concerns, please refer to the page entitled "Detergent Control".



Detergent Connection Point
(Machine rear view)

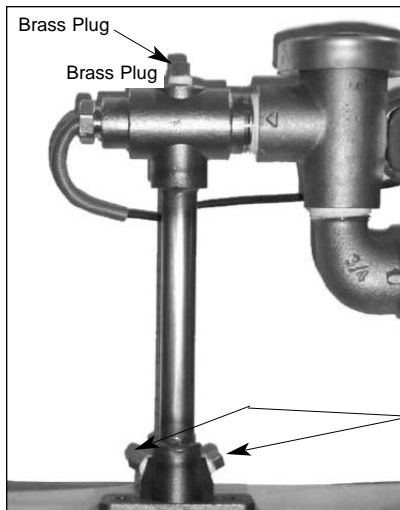

The 1/8" brass plugs on the incoming plumbing rinse injector may be removed to install rinse aid injection fittings.

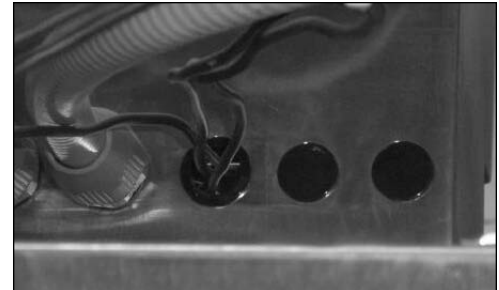

All wires for the chemical injectors should be routed through one of the extra openings in the back of the control box.

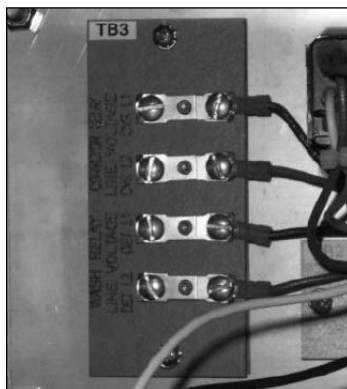

Connection Points

Terminals in the control box marked "CVS" provide a constant voltage signal whenever the drive motor is operating.

Terminals in the control box marked "DET" provide a voltage signal whenever the wash motor is operating.

SECTION 2: INSTALLATION/OPERATION INSTRUCTIONS

DELIMING OPERATIONS

DELIMING OPERATIONS: In order to maintain the dishmachine at its optimum performance level, it will be required to remove lime and corrosion deposits on a frequent basis. A deliming solution should be available from your detergent supplier. Read and follow all instructions on the label of the deliming solution.

To proceed with the deliming operation, fill the dishmachine and add the correct amount of deliming solution as recommended by the deliming solution manufacturer. The water capacity of the various tanks of the dishmachine can be verified on the specification sheet(s) of this manual.

Perform the following operations to delime the dishmachine:

1. Turn the AUTOMATIC/DELIME switch on the back of the control box to the DELIME position.
2. Disconnect or turn off all chemical feeder pumps.
3. Close all doors (after adding the deliming solution).
4. Run the machine for the recommended period of time.
5. Turn the unit off and open the doors.
6. Wait five minutes, then inspect the inside of the machine. If the machine is not delimed, run another time cycle as per the deliming solution's instructions.
7. When clean, drain and re-fill the machine.
8. Run in MANUAL for 10 minutes to remove residual deliming solution.
9. Drain and re-fill the machine.



Delime Switch

This equipment is not recommend for use with deionized water or other aggressive fluids. Use of deionized water or other aggressive fluids will result in corrosion and failure of materials and components. Use of deionized water or other aggressive fluids will void the manufacturer's warranty.

SECTION 2: INSTALLATION/OPERATION INSTRUCTIONS

CURTAIN INSTALLATION DIAGRAMS

Please refer to the chart for placement of the curtains.

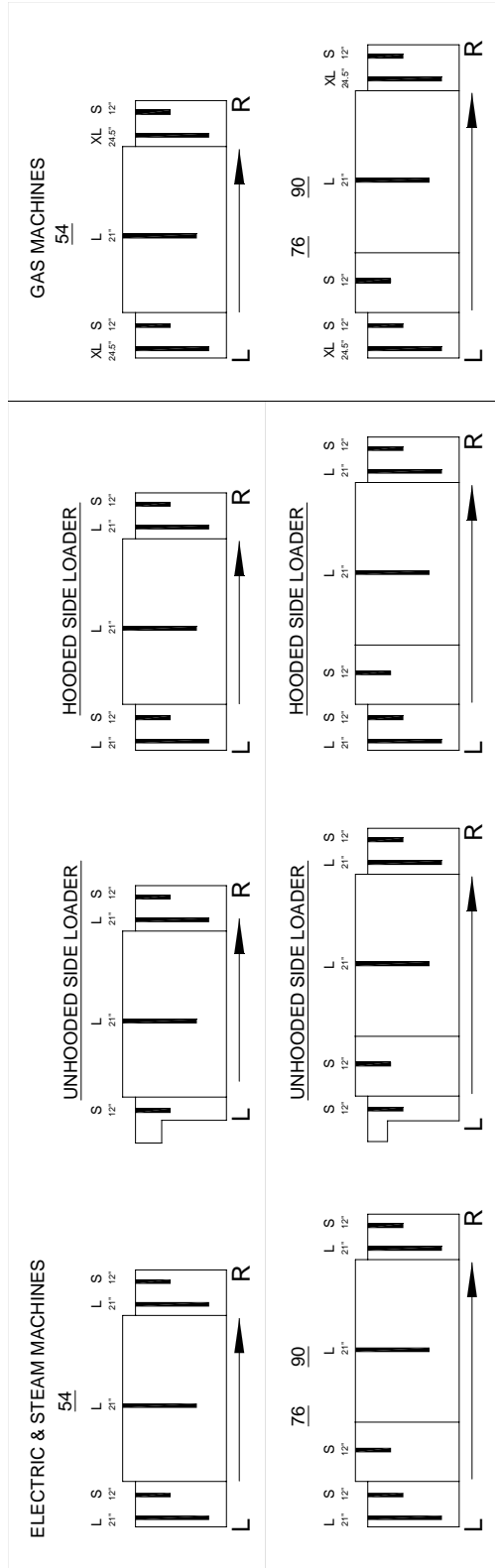

SECTION 2: INSTALLATION/OPERATION INSTRUCTIONS

SIDE LOADER INSTALLATION & OPERATION INSTRUCTIONS

This accessory assists in the delivery of a full dish rack from the break down (scrapping) table to the dishmachine. It will convert the direction of travel 90°. Since the Side Loader is shipped mounted on the conveyor dishwasher there is no additional installation required for this option. As it is operated mechanically by the dishwasher it does not require any plumbing or electrical connections.

This Side Loader does not require or add any additional electrical or mechanical devices to the unit which could create operational or maintenance problems. As designed the drive mechanism is powered by the conveyor drive motor on the dishmachine. An extension on the pawl bar provides the drive to push the racks into the unit.

PREPARATION: Before proceeding with the start-up of the unit, verify that the Side Loader pan strainer is installed.

WARE PREPARATION: Proper preparation of ware will help ensure good results and less re-washes. If not done properly, ware may not come out clean and the efficiency of the dishmachine will be reduced. It is important to remember that a dishmachine is not a garbage disposal and that simply throwing unscrapped dishes into the machine simply defeats the purpose altogether of washing the ware. Scraps should be removed from ware prior to being loaded into a rack. Pre-rinsing and pre-soaking are good ideas, especially for silverware and casserole dishes. Place cups and glasses upside down in racks so that they do not hold water during the cycle. The dishmachine is meant not only to clean, but to sanitize as well, to destroy all of the bacteria that could be harmful to human beings. In order to do this, ware must be properly prepared prior to being placed in the machine.

WASHING A RACK OF WARE: Once a rack is fully loaded it should be positioned against the front of the dish table. The rack should then be moved into the Side Loader until it activates the actuator switch. Once the the machine is started, it should pull the rack through the machine and push it out the unload end. Once a rack has started through, you may put another rack in.

OPERATIONAL INSPECTION: Based upon usage, the pan strainer may become clogged with soil and debris as the workday progresses. Operators should regularly inspect the pan strainer to ensure it has not become clogged. If the strainer does become clogged, it will reduce the washing capability of the machine. Instruct operators to clean out the pan strainer at regular intervals or as required by work load.

SHUTDOWN AND CLEANING: At the end of the workday, remove the pan strainer and clean as required. Wipe out the inside of the Side Loader and then reinsert the strainer.

SECTION 2: INSTALLATION/OPERATION INSTRUCTIONS

D226 STEAM BOOSTER INSTALLATION & OPERATION INSTRUCTIONS

CONCEALED DAMAGE OR MISSING PARTS:



IMPORTANT: FOR YOUR PROTECTION, PLEASE READ AND OBSERVE THE FOLLOWING:

This steam booster has been thoroughly inspected and carefully packed before leaving our warehouse.

Concealed loss or damage means loss or damage which does not become apparent until the booster has been unpacked. The contents may be damaged in transit due to rough handling even though the carton may not show external damage.

If it is found that the shipment has concealed damage, PLEASE DO NOT RETURN IT TO JACKSON, but notify the carrier (within 48 hours) asking them to send their agent to fill out an inspection report. Save the cartons so he may inspect them and be sure to note in the report any black marks, creases, tears, crushed corners or any other marks indicating rough handling. Also, notify your JACKSON dealer immediately.

If it is discovered that there are missing parts, please notify your JACKSON dealer immediately.

EQUIPMENT MOUNTING:

Your booster should come pre-assembled and will require that it be permanently mounted in place. The platform has pre-punched holes to allow for mounting to the installation floor. **NOTE:** The D226 Booster must be properly mounted and level before being used. Once the platform is secure to the floor, attach the water and steam lines in accordance with local and national codes.

PLUMBING:

NOTE: ALL CONNECTIONS MUST COMPLY WITH ALL APPLICABLE LOCAL, STATE AND NATIONAL PLUMBING CODES.

The plumber is responsible for ensuring that the water line is **THOROUGHLY FLUSHED BEFORE** connecting it to any manual or solenoid valve. It is necessary to remove all foreign matter such as chips (resulting from cutting or threading pipes), pipe joint compound or, if soldered fittings are used, bits of solder or cuttings from the lines. This debris, if not removed, may lodge in the valves and render them inoperative.

The D226 Booster is designed to take incoming water from a minimum temperature of 110°F to approximately 180°F for use in the final rinse of your Jackson dishmachine. In order to do this, water is supplied to the booster and is heated by tubes carrying 15-25 PSIG flow steam. Heat is transferred from the steam into the water, raising the temperature.

Install condensate drains in accordance with applicable codes.

The D226 Booster is designed to operate at a water flow rate of 20 ± 5 PSI. The assembly comes with a water pressure regulator, which is preset at the factory. However, adjustment may be required so ensure that you verify the the flow pressure before beginning operations. See the instructions regarding adjustment and maintenance of the water pressure regulator for more information.



WARNING: The D226 Booster is designed to heat water to a minimum of 180°F and is extremely hot during operations. Advise personnel of the dangers associated with touching booster components as burns or severe injury can occur.



This equipment is not recommend for use with deionized water or other aggressive fluids. Use of deionized water or other aggressive fluids will result in corrosion and failure of materials and components. Use of deionized water or other aggressive fluids will void the manufacturer's warranty.

SECTION 2: INSTALLATION/OPERATION INSTRUCTIONS

D226 STEAM BOOSTER INSTALLATION & OPERATION INSTRUCTIONS (CONTINUED)

ELECTRICAL:

WARNING: Electrical and grounding connections must comply with applicable portions of the National Electrical Code ANSI / NFPA 70 (latest edition) and/or other electrical codes. Disconnect electrical power supply and place a tag or lock at the disconnect switch to indicate that you are working on the circuit.

To connect the incoming power, run the conduit for power wires through the open hole in the back of the control box. Connect the power wires to the terminal block as it is labeled (L1 and L2). Run the ground wire to the grounding lug marked "GND". Tight connections and conduit nuts and close the control box by putting the cover on and securing with the 10-32 screws.

OPERATION:

WARNING: The heat exchanger used in the D226 Booster system is a pressure vessel with very precise operating parameters. Safety equipment such as relief valves should never be tampered with or disabled. These devices are meant to protect the equipment and the operator from harm, damage and death.

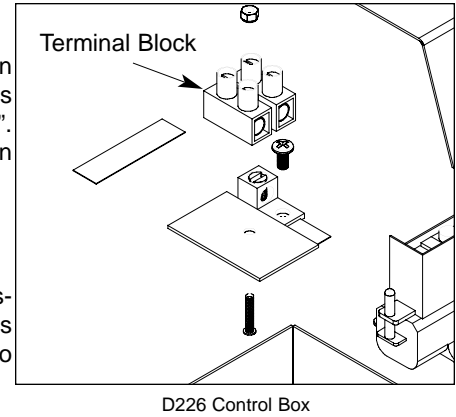

1. Ensure that water, steam and any condensate drains are connected to the booster.
2. Start the water flow first, open the condensate drains and then begin steam flow.
3. On the control box, press the power switch and put it in the ON position. The power light should illuminate.

The unit should run normally now.

WARNING: Do not shock the system by applying the steam before the water. This can cause damage to the booster.

The following explanation describes the operation of the D226 Booster.

NOTE: This explanation assumes that water and steam have been connected to the machine.

1. When the power switch (S1) is placed in the ON position, power is provided to both the power light (E1) and the thermostat (TS1).
2. The thermostat (TS1) will close when the water falls below the minimum setpoint, energizing the steam solenoid light (E2) and the steam solenoid (FS1).
3. The steam solenoid (FS1) will remain open, allowing steam into the booster, until the water temperature reaches the desired temperature. At that point, the thermostat (TS1) will open, de-energizing the steam solenoid (FS1) and the steam solenoid light (E2).

IMPORTANT: Please remember that all of the components in the control box are under line voltage (208-240 volts). Under no circumstance is the control box cover to be removed or opened during normal operations!

SHUTDOWN (FOR SERVICE ONLY):

WARNING: The D226 Booster is designed to heat water to a minimum of 180°F and is extremely hot during operations. Advise personnel of the dangers associated with touching booster components as burns or severe injury can occur.

1. Turn the power switch to the OFF position. The power light should extinguish.
2. Secure steam flow to the unit.
3. Secure water flow.
4. Close the condensate drains as required by procedure and/or code.
5. Do not attempt to clean, wipe down or perform any maintenance on the booster until it has been given a generous amount of time to cool down.

SECTION 2: INSTALLATION/OPERATION INSTRUCTIONS

GAS CONVEYOR HOSE INSTALLATION

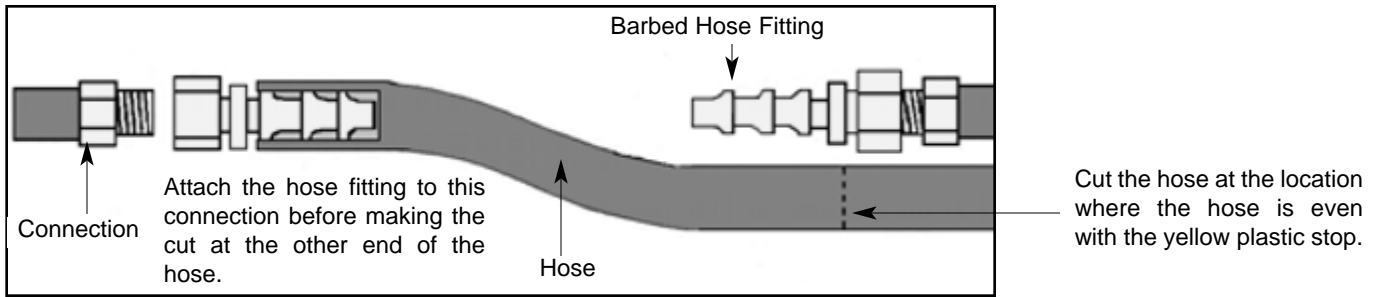

Due to the fact that each customer may have different requirements for the orientation of the gas booster heater relative to the main dishmachine, the hose lengths that connect the two units must be customized during each installation. The appropriate 3/4" hosing, fittings and gaskets have been provided.

To prevent incorrect measurements of the hose, it is recommended to place one barbed hose fitting into the end of the uncut length of hose coil and attach that fitting to an appropriate connection. Run the hose to the corresponding connection on the other unit before cutting the hose. Use a barbed hose fitting that is screwed into the second connection on the other unit before cutting the hose. Use a barbed hose fitting that is screwed onto the second connection to gauge the correct distance. Ensure a smooth "flow" of hose without any sharp turns or kinks.

To aid in pushing the barbed hose fitting into the hose, place the fitting on a hard surface (i.e. the floor) with the barbed end of the fitting pointing upward and push the hose down onto the fitting. A small amount of lubricant (i.e. petroleum jelly) may aid in this process.

SECTION 2: INSTALLATION/OPERATION INSTRUCTIONS

GAS CONVEYOR HOSE INSTALLATION (CONTINUED)

TYPICAL RECIRCULATING WATER HOOK-UP FOR ALL GAS HEATED CONVEYORS

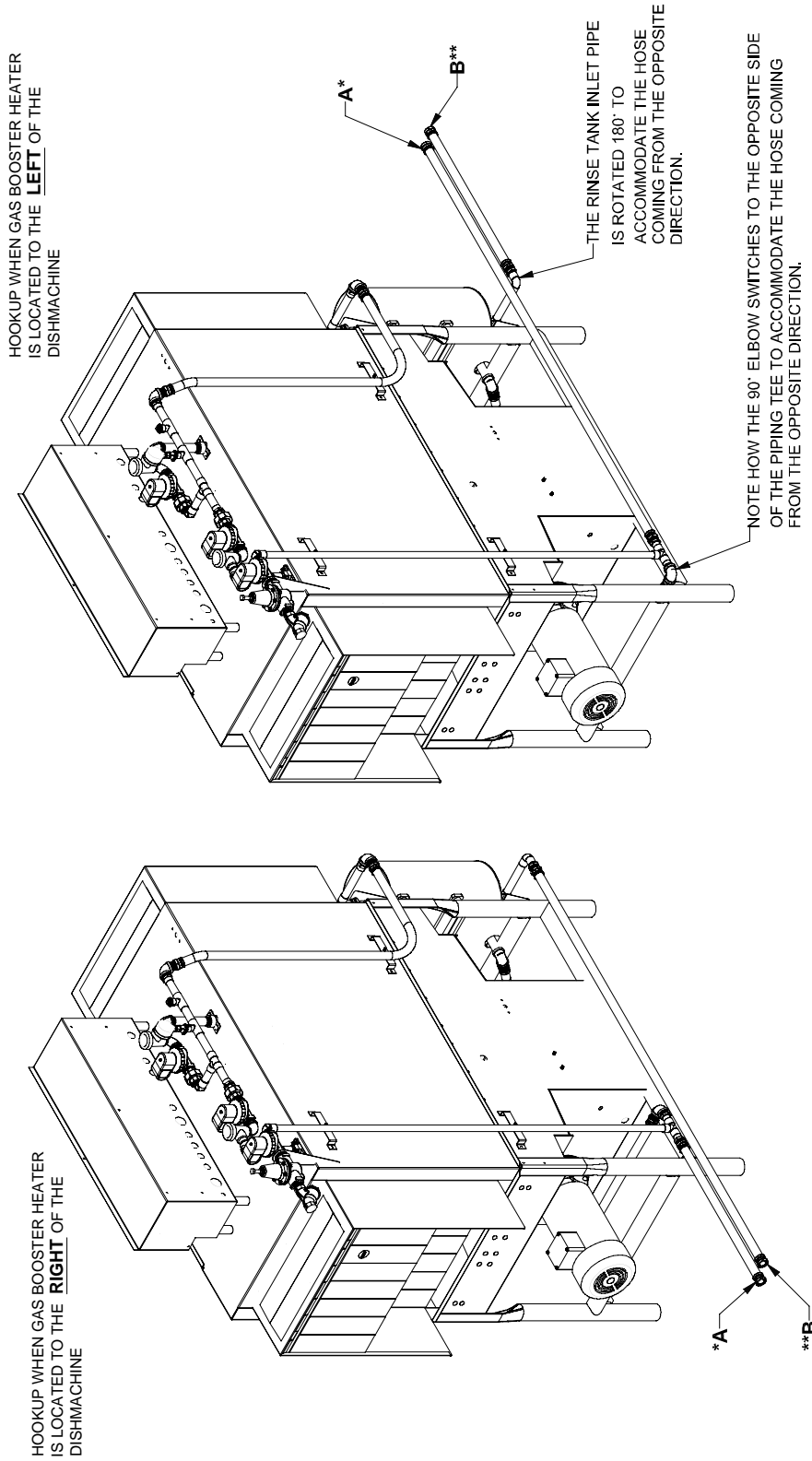

CONNECTION HOSES ARE CUT TO LENGTH DURING INSTALLATION.

(ENOUGH HOSE IS PROVIDED TO LOCATE THE GAS BOOSTER HEATER APPROXIMATELY 9 FEET AWAY FROM THE DISHMACHINE. ADDITIONAL HOSE MUST BE ORDERED IF A GREATER DISTANCE IS REQUIRED. DISTANCES GREATER THAN 20 FEET AWAY CAN AFFECT THE HEATING PERFORMANCE OF THE UNIT)

- * HOSES MARKED **A** IN THE ABOVE ILLUSTRATIONS CONNECT TO THE **INLET** WATER CONNECTION OF THE GAS BOOSTER HEATER
- ** HOSES MARKED **B** IN THE ABOVE ILLUSTRATIONS CONNECT TO THE **OUTLET** WATER CONNECTION OF THE GAS BOOSTER HEATER

SECTION 2: INSTALLATION/OPERATION INSTRUCTIONS

DISHMACHINE OPERATING INSTRUCTIONS

PREPARATION: Before proceeding with the start-up of the unit, verify the following:

1. Close door(s) on dishmachine.
2. Close the drain valve(s).

POWER UP (ELECTRICALLY-HEATED MODELS): To energize the unit, turn on the power at the service breaker. The voltage should have been previously verified as being correct. If not, the voltage will have to be verified.

POWER UP (STEAM-HEATED MODELS): To energize the unit, turn on the power at the service breaker. The voltage should have been previously verified as being correct. If not, the voltage will have to be verified. Ensure that the steam service is connected and that steam is flowing to the machine. Without steam, the water will not reach the required minimum temperatures that the machine is designed to operate at.

POWER UP (GAS-HEATED MODELS): To energize the unit, turn on the power at the service breaker. The voltage should have been previously verified as being correct. If not, the voltage will have to be verified. Ensure that the gas service is connected and that gas is flowing to the machine. Without gas, the water will not reach the required minimum temperatures that the machine is designed to operate at.

FILLING THE WASH TUB: Ensure that the delime switch is in the NORMAL position, and place the power switch into the ON position. The machine should fill automatically and shut off when the appropriate level is reached (just below the pan strainer). The wash tub must be completely filled before operating the wash pump to prevent damage to the component. Once the wash tub is filled, the unit is ready for operation.



Machines equipped with prewash sections should not be run without water in those sections. This can cause damage to components.

WARE PREPARATION: Proper preparation of ware will help ensure good results and less re-washes. If not done properly, ware may not come out clean and the efficiency of the dishmachine will be reduced. It is important to remember that a dishmachine is not a garbage disposal and that simply throwing unscrapped dishes into the machine simply defeats the purpose altogether of washing the ware. Scraps should be removed from ware prior to being loaded into a rack. Pre-rinsing and pre-soaking are good ideas, especially for silverware and casserole dishes. Place cups and glasses upside down in racks so that they do not hold water during the cycle. The dishmachine is meant not only to clean, but to sanitize as well, to destroy all of the bacteria that could be harmful to human beings. In order to do this, ware must be properly prepared prior to being placed in the machine.

DAILY MACHINE PREPARATION: Refer to the section entitled "PREPARATION" at the top of this page and follow the instructions there. Afterwards, check that all of the chemical levels are correct and/or that there is plenty of detergent available for the expected workload.

WASHING A RACK OF WARE: To wash a rack, simply slide a rack of soiled ware into the load end of the machine. Once the machine is started, it should pull the rack through the machine and push it out the unload end. Once a rack has started through, you may put another rack in.

OPERATIONAL INSPECTION: Based upon usage, the pan strainers may become clogged with soil and debris as the workday progresses. Operators should regularly inspect the pan strainers to ensure they have not become clogged. If the strainers do, they will reduce the washing capability of the machine. Instruct operators to clean out the pan strainers at regular intervals or as required by work load.

NOTE: On units equipped with prewash sections (AJ-76 and AJ-90), operators should also take the time to inspect the prewash section strainers and clean them as required by workload.

SHUTDOWN AND CLEANING (ELECTRICALLY-HEATED MODELS): At the end of the workday, place the power switch in the OFF position and open the door(s). Open the drain valves and allow the machine to drain completely. Remove the pawl bar assembly (clean as required). Remove the pan strainers and, if equipped, the prewash strainers, run off sheets and scrap basket strainer. Remove the wash and, if equipped, the prewash arms and verify that the nozzles and arms are free from obstructions. Flush the arms with fresh water. Remove the pump suction strainers and clean out as required. Remove the rinse tray assembly and clean. Remove the curtains and scrub with a mild detergent and warm water. Wipe out the inside of the unit and then reassemble with the components previously removed.

SECTION 2: INSTALLATION/OPERATION INSTRUCTIONS

DISHMACHINE OPERATION INSTRUCTIONS (CONTINUED)

SHUTDOWN AND CLEANING (STEAM-HEATED MODELS): At the end of the workday, place the power switch in the OFF position, secure the flow of steam to the machine and open the door(s). Open the drain valves and allow the machine to drain completely. Remove the pawl bar assembly (clean as required). Remove the pan strainers and, if equipped, the prewash strainers, run off sheets and scrap basket strainer. Remove the wash and, if equipped, the prewash arms and verify that the nozzles and arms are free from obstructions. Flush the arms with fresh water. Remove the pump suction strainers and clean out as required. Remove the rinse tray assembly and clean. Remove the curtains and scrub with a mild detergent and warm water. Wipe out the inside of the unit and then reassemble with the components previously removed.

SHUTDOWN AND CLEANING (GAS-HEATED MODELS): At the end of the work day, shut down the gas booster in accordance with manufacturer's instructions. Place the power switch in the OFF position, secure the flow to the machine and open the door(s). Open the drain valves and allow the machine to drain completely. Remove the pawl bar assembly (clean as required). Remove the pan strainers and, if equipped, the prewash strainers, run off sheets and scrap basket strainer. Remove the wash and, if equipped, the prewash arms and verify that the nozzles and arms are free from obstructions. Flush the arms with fresh water. Remove the pump suction strainers and clean out as required. Remove the rinse tray assembly and clean. Remove the curtains and scrub with a mild detergent and warm water. Wipe out the inside of the unit and then reassemble with the components previously removed.

SECTION 2: INSTALLATION/OPERATION INSTRUCTIONS

DETERGENT CONTROL

Detergent usage and water hardness are two factors that contribute greatly to how efficiently your dishmachine will operate. Using detergent in the proper amount can become, in time, a source of substantial savings. A qualified water treatment specialist can tell you what is needed for maximum efficiency from your detergent, but you should still know some basics so you'll understand what they are talking about.

First, you must understand that hard water greatly effects the performance of the dishmachine. Water hardness is the amount of dissolved calcium and magnesium in the water supply. The more dissolved solids in the water, the greater the water hardness. Hard water works against detergent, thereby causing the amount of detergent required for washing to increase. As you use more detergent, your costs for operating the dishmachine will increase and the results will decrease. The solids in hard water also may build-up as a scale on wash and rinse heaters, decreasing their ability to heat water. Water temperature is important in removing soil and sanitizing dishes. If the water cannot get hot enough, your results may not be satisfactory. This is why Jackson recommends that if you have installed the machine in an area with hard water, that you also install some type of water treatment equipment to help remove the dissolved solids from the water before it gets to the dishmachine.

Second, hard water may have you adding drying agents to your operating cycle to prevent spotting, when the real problem is deposited solids on your ware. As the water evaporates off of the ware, the solids will be left behind to form the spotting and no amount of drying agent will prevent this. Again, using treated water will undoubtedly reduce the occurrences of this problem.

Third, treated water may not be suitable for use in other areas of your operation. For instance, coffee made with soft water may have an acid or bitter flavor. It may only be feasible to install a small treatment unit for the water going into the dishmachine itself. Discuss this option with your qualified water treatment specialist.

Even after the water hardness problems have been solved, there still must be proper training of dishmachine operators in how much detergent is to be used per cycle. Talk with your water treatment specialist and detergent vendor and come up with a complete training program for operators. Using too much detergent has as detrimental effects as using too little. The proper amount of detergent must be used for job. It is important to remember that certain menu items may require extra detergent by their nature and personnel need to be made aware of this. Experience in using the dishmachine under a variety of conditions, along with good training in the operation of the machine, can go a long way in ensuring your dishmachine operates as efficiently as possible.

Certain dishmachine models require that chemicals be provided for proper operation and sanitization. Some models even require the installation of third-party chemical feeders to introduce those chemicals to the machine. Jackson does not recommend or endorse any brand name of chemicals or chemical dispensing equipment. Contact your local chemical distributor for questions concerning these subjects.

Some dishmachines come equipped with integral solid detergent dispensers. These dispensers are designed to accommodate detergents in a certain sized container. If you have such a unit, remember to explain this to your chemical distributor upon first contacting them.

As explained before, water temperature is an important factor in ensuring that your dishmachine functions properly. The data plate located on each unit details what the minimum temperatures must be for either the incoming water supply, the wash tank and the rinse tank, depending on what model of dishmachine you have installed. These temperatures may also be followed by temperatures that Jackson recommends to ensure the highest performance from you dishmachine. However, if the minimum requirements are not met, the chances are your dishes will not be clean or sanitized. Remember, a dish can look clean, but it may not be sanitized. Instruct your dishmachine operators to observe the required temperatures and to report when they fall below the minimum allowed. A loss of temperature can indicate a much larger problem such as a failed heater or it could also indicate that the hot water heater for your operation is not up to capacity and a larger one may need to be installed.

There are several factors to consider when installing your dishmachine to ensure that you get the best possible results from it and that it operates at peak efficiency for many years. Discuss your concerns with your local chemical distributor and water treatment specialist before there is a problem.

SECTION 2: INSTALLATION/OPERATION INSTRUCTIONS

PHOTOELECTRIC LIMIT SWITCH INSTALLATION INSTRUCTIONS

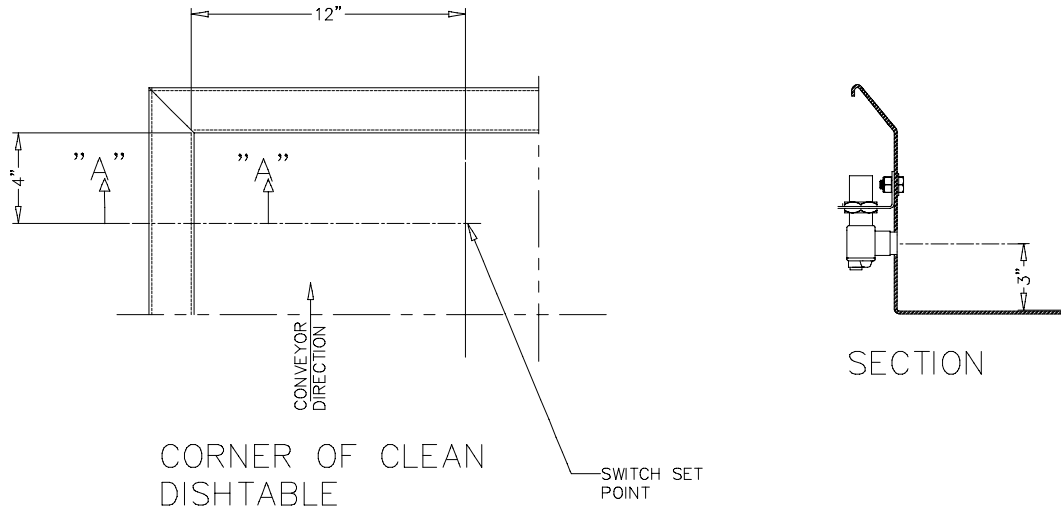

BRACKET MOUNTING TEMPLATE

Installation Instructions:

1. Locate and drill a 3/4" diameter hole through the back of the dishtable, 4" from the end and 3" above the surface of the table.
2. Using the switch mounting bracket template (a photocopy of it may prove beneficial), locate and drill the 9/32" diameter hole on either side of the 3/4" hole.
3. Mount the switch bracket to the outside of the dishtable using the 1/4"-20 hardware supplied. The cable entering the switch body should be pointing upwards so that the switch sensitivity adjustment screw is downwards for adjusting from the underside of the table.
4. Wiring instructions:
 - a. White wire from the conveyor control panel to red/black wire from proximity switch.
 - b. Door switch wire from the conveyor control panel to the black wire from the proximity switch.
 - c. Black/white wire from the conveyor control panel to the red/white wire from the proximity switch.
5. Adjust the sensitivity of the proximity switch by turning the adjustment screw on the switch. The proper setting is reached when the switch will sense an object approximately 12" from the switch.

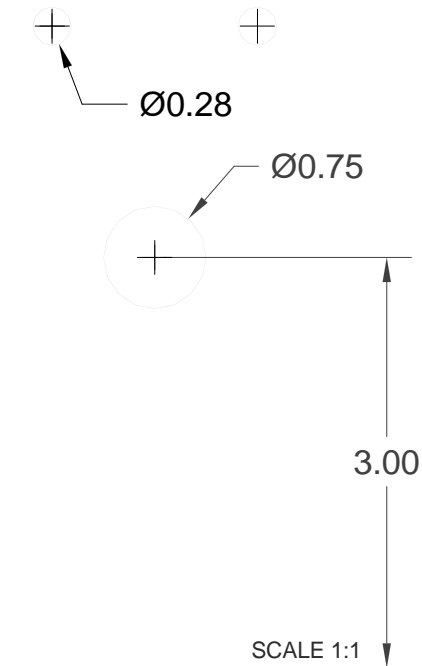

Unless noted, all dimensions are in inches.

SECTION 2: INSTALLATION/OPERATION INSTRUCTIONS

STRIKER PLATE LIMIT SWITCH INSTALLATION INSTRUCTIONS

Installation Instructions:

1. Wiring: The switch is wired common and normally open because of the hinge design. By interrupting the line in series with the door switches, the dishmachine ceases to operate. Refer to the machine schematic for details on how to wire the switch.

2. Parts of the table switch are mounted in the dishtable, at the end of the table and under the table. See the drawing(s) for the relationship of the switch to the table.

3. Move the limit switch as far down on the two slots as possible and see that the limit switch is straight on the base plate. This might require adjustment of the nut on the connector for the limit switch.

4. Then adjust the inside and the outside connector nuts for the connector box so that it lines up even with the limit switch and the base plate.

5. Tighten down the nuts for the seal so that they are tight.

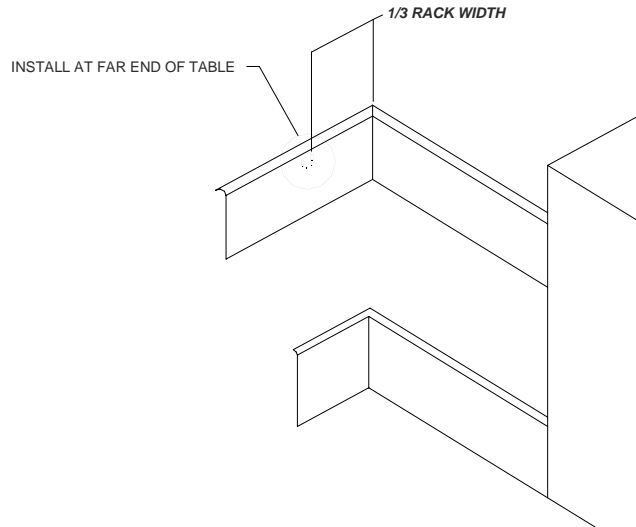

6. If you have any difficulty you might have to adjust the connectors to the seal, screwing in or screwing out until the installation is straight on the table and the limit switch is actuated correctly by the rack.

TABLE LIMIT SWITCH THROUGH ROD HOLES

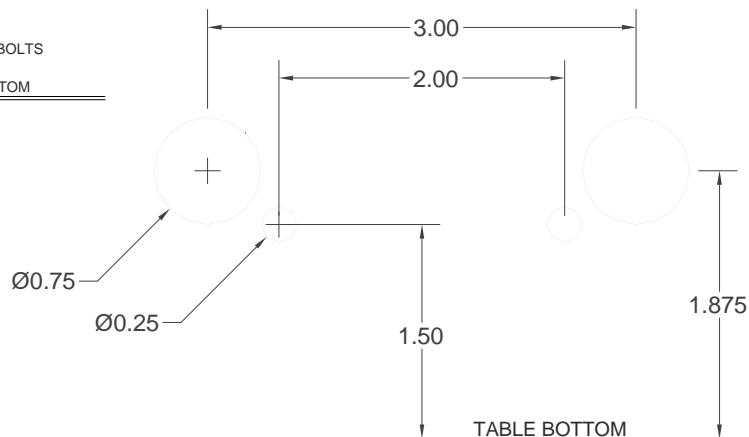
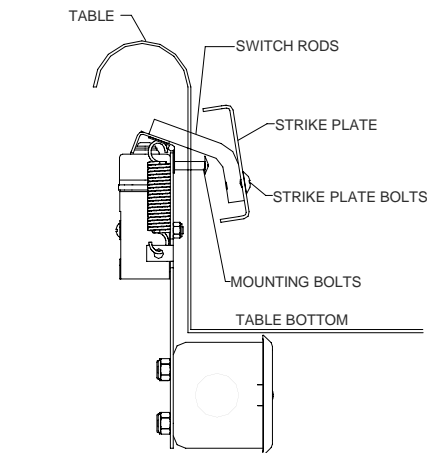

Unless noted, all dimensions are in inches.

SECTION 2: INSTALLATION/OPERATION INSTRUCTIONS

WHISKER LIMIT SWITCH INSTALLATION INSTRUCTIONS

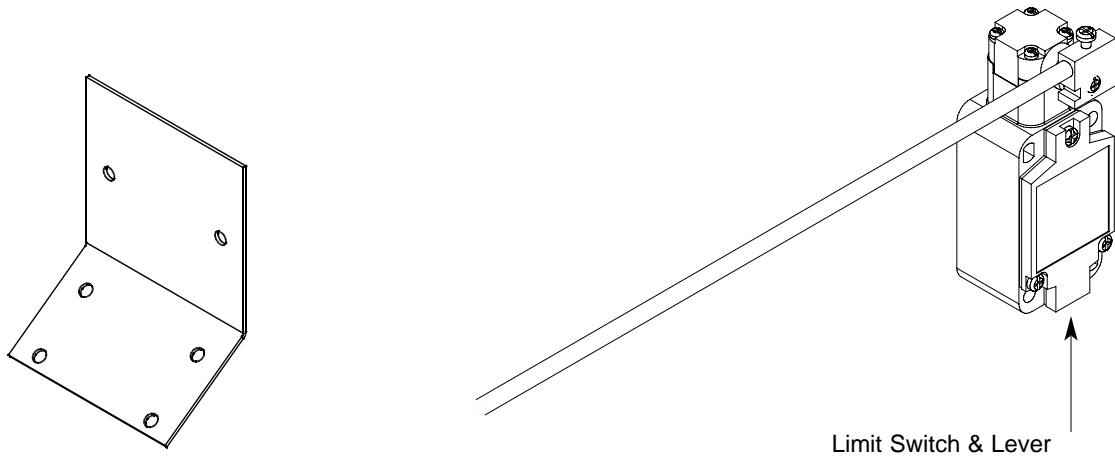

Switch Mounting Bracket

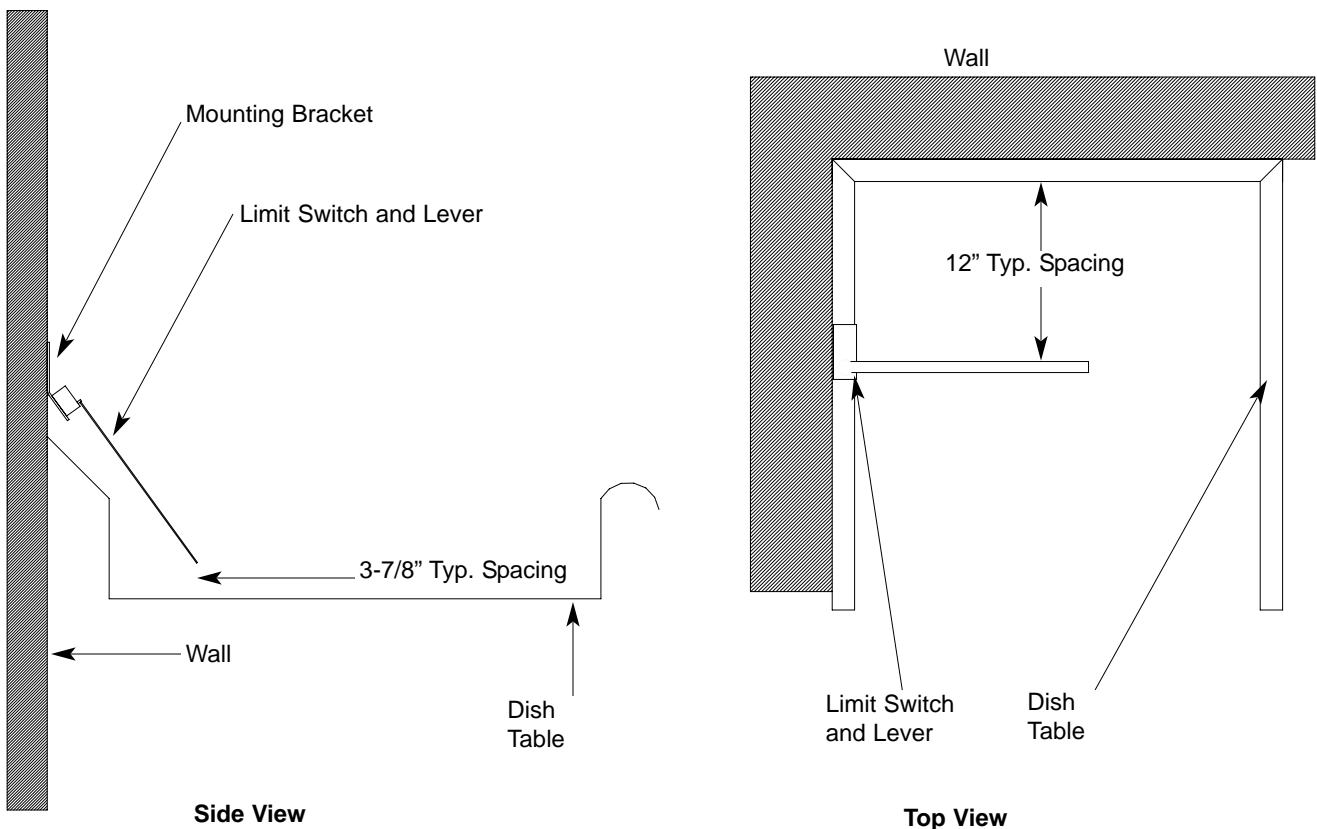

Side View

Top View

Installation Instructions:

1. Wiring: Refer to the machine schematic.
2. Mounting: Mount the switch as indicated in the drawing(s) above.

SECTION 3: PREVENTATIVE MAINTENANCE

SECTION 3: PREVENTATIVE MAINTENANCE

PREVENTATIVE MAINTENANCE

The dishmachines covered in this manual are designed to operate with a minimum of interaction with the operator. However, this does not mean that some items will not wear out in time. Jackson highly recommends that any maintenance and repairs not specifically discussed in this manual should be performed by **QUALIFIED SERVICE PERSONNEL ONLY**. Performing maintenance on your dishmachine may void your warranty if it is still in effect, so if you have a question or concern, do not hesitate to contact Jackson.

There are many things that operators can do to prevent catastrophic damage to the dishmachine. One of the major causes of component failure has to do with prescraping procedures. A dishmachine is not a garbage disposal; any large pieces of material that are put into the machine shall remain in the machine until they are either broken up (after spreading out on your ware!) or physically removed. Strainers are installed to help catch debris, but they do no good if they are clogged. Have operators regularly inspect the pan strainers to ensure (1) that they are free of soil and debris and (2) they are laying flat in the tub.

When cleaning out strainers, do **NOT** beat them on waste cans. The strainers are made of metal and can be forgiving; but once severe damage is done, it is next to impossible for the strainer to work in the way it was designed to. Wipe out strainers with a rag and rinse under a faucet if necessary. For stubborn debris, a toothpick should be able to dislodge any obstructions from the perforations. Always ensure that strainers are placed back in the machine before operation and that they lay flat in the tub.

You may wish to also refer to the page entitled "Detergent Control" in order to learn more about how your water hardness will effect the performance of your machine. Hard water makes dishmachines work harder and decreases efficiency.

Again, it is important to remind operators that trying to perform corrective maintenance on the dishmachine could lead to larger problems or even cause harm to the operator. If a problem is discovered; secure the dishmachine using proper shut down procedures as listed in this manual and contact Jackson.

Some problems, however, may have nothing to do with the machine itself and no amount of preventative maintenance is going to help. A common problem has to do with temperatures being too low. Verify that the water temperatures coming to your dishmachine match the requirements listed on the machine data plate. There can be a variety of reasons why your water temperature could be too low and you should discuss it with Jackson to determine what can be done.

By following the operating and cleaning instructions in this manual, you should get the most efficient results from your machine. As a reminder, here are some steps to take to ensure that you are using the dishmachine the way it was designed to work:

1. Ensure that the water temperatures match those listed on the machine data plate.
2. Ensure that all strainers are in place before operating the machine.
3. Ensure that all wash and/or rinse arms are secure in the machine before operating.
4. Ensure that drains are closed/sealed before operating.
5. Remove as much soil from dishes by hand as possible before loading into racks.
6. Do not overfill racks.
7. Ensure that glasses are placed upside down in the rack.
8. Ensure that all chemicals being injected to machine have been verified as being at the correct concentrations.
9. Clean out the machine at the end of every workday as per the instructions in the manual.
10. Always contact Jackson whenever a serious problem arises.
11. Follow all safety procedures, whether listed in this manual or put forth by local, state or national codes/regulations.

SECTION 3: PREVENTATIVE MAINTENANCE

D226 MAINTENANCE

 **WARNING:** Maintenance should only be performed by authorized service personnel in order to ensure safe and effective workmanship, while minimizing danger to operating personnel. The D226 Steam Booster is designed to operate at temperatures capable of causing burns to personnel. Always allow the unit to cool down to an acceptable temperature prior to performing any maintenance.

Very little maintenance is required to be performed on the D226 Booster. So long as the steam and water used with the unit have the proper filtration and are operated at the correct temperature and pressures, then you should expect many years of reliable service out of your system.

MAINTENANCE OF THE WATER PRESSURE REGULATOR:

Incoming water pressure can be regulated by adjusting the water pressure regulator on the system. In order to adjust pressure, loosen the top nut on the regulator. This will allow you to turn the adjusting screw. Turn the adjusting screw clockwise to increase pressure and counter-clockwise to decrease. Pressure can be read on the pressure gauge located on the water outlet side of the heat exchanger. Once the desired pressure is achieved, tighten the top nut to ensure that the adjustment cannot be accidentally changed.

The water pressure regulator has an internal strainer that can be removed through the bottom hexagonal plug. This may need to be periodically checked depending on the water quality. It is important that the water supply to the water pressure regulator be secured prior to trying to clean the strainer.

MAINTENANCE OF THE RELIEF VALVES, SAFETY VALVES AND THERMOSTAT:

These components are shipped from the factory preset and should not be tampered with. None of these components are considered adjustable and no attempt should be made to do so. If a component does not appear to be working properly, then it should be replaced immediately by an authorized service representative.

SECTION 3: PREVENTATIVE MAINTENANCE

DRIVE MOTOR GEAR REDUCER PREVENTATIVE MAINTENANCE

Note: The maintenance procedures detailed here are manufacturer's instructions for the WINSMITH brand of gear reducer that is installed on the rack conveyors covered in this manual.

Lubrication & Maintenance:

Factory filling - WINSMITH speed reducers are oil filled at the factory to the proper level for the standard mounting position that you will find it in on the unit. The oil level should be checked and adjusted (if necessary) prior to operation, using the oil level plug provided and while the unit is oriented in its operating position.

Ambient temperature - If the operating ambient temperature is other than 51 - 95°F, then refer to the lubrication chart and refill the unit with the correct grade based on actual ambient temperature and operating speed. See "Oil changing" below for additional information.

Oil changing - When changing the oil for any reason, it should be remembered that oils of various types may not be compatible. Therefore, when changing to a different oil, it is recommended that the housing be completely drained and thoroughly flushed with a light flushing oil prior to refilling with the appropriate lubricant. The oil level should be rechecked after a short period of operation and adjusted, if necessary. When changing double reduction models, each housing should be drained and filled independently, even though there may be a common level.

Initial oil change: The new oil in a speed reducer should be changed at the end of 250 hours of operation. This is equivalent to 30 days of operation for 8 hours per day; 15 days of operation for 16 hours per day, or 10 days of operation for 24 hours per day.

Subsequent oil changes: Under normal conditions, after the initial oil change, the oil should be changed after every 2500 hours of operation, or every 6 months, whichever occurs first. Under severe conditions (rapid temperature changes, moist, dirty or corrosive environment) it may be necessary to change oil at intervals of one to three months. Periodic examination of oil samples taken from the unit will help establish the appropriate interval.

Synthetic oils: Synthetic lubricants can be advantageous over mineral oils in that they generally are more stable, have a much longer life, and operate over a wider temperature range. These oils are appropriate for any application but are especially useful when units are subjected to low start-up temperatures or high operating temperatures. However, continuous operation above 225°F may cause damage to seals or other components. It is recommended that the initial oil be changed or filtered after the first 1500 hours of operation to remove metal particles that accumulate during break-in. Subsequent oil changes should be made after 5000 hours operation if units are operating in a clean environment. This can be extended to 10,000 hours if using new reformulated Mobil SHC lubricants (orange in color) and the lubricant remains free of contamination over this period. See comments under "Subsequent oil changes" for discussion of severe ambient conditions.

Long term storage or infrequent operation: If a speed reducer is to stand idle for an extended period of time, either prior to installation or during use, it is recommended that the unit be filled completely with oil to protect interior parts from rust and corrosion due to internal condensation. Be sure to drain the oil to the proper level before placing the speed reducer in service.

Grease fittings: Some units are equipped with grease fittings to lubricate bearings not adequately lubricated by the oil splash. These fittings must be lubricated every 3 - 6 months depending on operating conditions. bearing greases must be compatible with the type of gear lubricant being used (i.e. mineral, synthetic, food grade, etc.). For mineral oils, use a high quality lithium base NLGOI #2 bearing grease. For synthetic oils, use a synthetic bearing grease such as Mobil Synthetic Universal grease, Mobilith SHC 100 or a suitable equivalent. For food grade lubricants, use Chevron FM grease, NGLI 2, or equivalent.

Low input speeds (under 1600 RPM): When input speeds are less than 1600 RPM, grease fittings will be required to lubricate any bearings not partially covered by the normal oil level.

Oil temperature: Speed reducers in normal operation can generate temperatures up to 200°F depending on the type of reducer and the severity of the application (loading, duration of service, ambient temperatures). Excessive oil temperatures may be the result of several factors including overloading, overfilling, underfilling or inadequate cooling.

Size	Nominal Ratio											
	5	7.5	10	15	20	25	30	40	50	60	80	100
920	0.347	0.263	0.225	0.216	0.202	0.191	0.215	0.200	0.188	0.182	0.164	0.161

Lubricant selections are provided by the lubricant manufacturer based on AGMA recommended viscosity grades. Viscosity grades are based on Lubrication Standard ANSI/AGMA 9005-D94.

SECTION 4: TROUBLESHOOTING SECTION

SECTION 4: TROUBLESHOOTING

COMMON PROBLEMS



WARNING: Inspection, testing and repair of electrical equipment should be performed only by qualified service personnel. Certain procedures in this section require electrical tests or measurements while power is applied to the machine. **Exercise extreme caution at all times.** If test points are not easily accessible, disconnect power, attach test equipment and reapply power to test. When replacing electrical parts, disconnect power at source circuit breaker

Problem: Nothing on dishmachine operates. The power switch is ON and the power indicator light is OFF.

1. Machine is not wired correctly to incoming power source. Have an electrician verify wiring.
2. Machine circuit breaker is tripped. Reset the circuit breaker. If it trips again, contact an electrician to verify the machine amp draw.
3. Service breaker is tripped. Reset the service breaker. If it trips again, contact an electrician to verify the machine amp draw.

Problem: Machine will not fill. The power switch is ON and the power indicator light is ON.

1. No water supply to machine. Verify that water lines have been connected to the machine.
2. Dishmachine doors are not closed. Close doors completely.
3. Incoming water solenoid valve damaged/faulty. Verify that the valve is operating. If not, replace.
4. Tank floats faulty. Verify the wiring of the floats. Verify that no debris is jamming the floats. Replace if necessary.

Problem: Machine fills, but fill is weak.

1. Low incoming water pressure. Verify that incoming water pressure during fill is 20 ± 5 PSI.
2. Incoming water solenoid is clogged. Verify that debris is not entrapped in valve. If so, remove debris.

Problem: Low wash tank temperature.

1. Low incoming water temperature. Verify that the incoming water temperature matches what is indicated on the machine data plate.
2. Heater not energizing. Verify that the wash tank heater is operating. If not, replace.
3. Low incoming voltage. Have an electrician verify that the power coming to the machine is the same as indicated on the data plate.

Problem: Low wash arm pressure, poor spray pattern.

1. Clogged wash arm nozzles. Verify that nozzles are not clogged with debris. If so, remove debris.
2. Clogged wash tank or wash pump strainers. Clean out strainers if necessary.
3. Worn wash pump impeller. Verify status of impeller, replace if necessary.

Problem: Low prewash arm pressure, poor spray pattern.

1. Clogged prewash arm nozzles. Verify that nozzles are not clogged with debris. If so, remove debris.
2. Clogged prewash tank or prewash pump strainers. Clean out strainers if necessary.
3. Worn prewash pump impeller. Verify status of impeller, replace if necessary.

Problem: Inadequate rinse.

1. Low incoming water pressure. Verify that incoming water pressure during fill is 20 ± 5 PSI.
2. Incoming water solenoid is clogged. Verify that debris is not entrapped in valve. If so, remove debris.

Problem: Pawl bar moves with no load, but does not move when loaded.

1. Clutch on drive assembly is out of adjustment. Adjust as required.

SECTION 4: TROUBLESHOOTING

COMMON PROBLEMS

Problem: Pawl bar does not move.

1. Failed or broken overload spring. Replace spring if necessary.
2. No power to the drive motor/failed drive motor. Verify power and wiring connections to the motor. If necessary, replace the motor.
3. Pawl bar not properly installed. Verify that the pawl bar is installed correctly.

Problem: Racks go through the machine, but results are poor.

1. Verify that detergent is being dispensed into the machine at the appropriate quantities for the water volume. If not, get detergent to appropriate level and review results of washing ware.
2. Clogged strainers/scrap basket. Clean out strainers and scrap basket and replace.
3. Ware not being properly prescrapped. Review paragraph entitled "Ware Preparation" in Operating Instructions.
4. Wash or rinse arms missing end plugs or caps. Verify and replace as required.
5. Low tank heat.
6. Inadequate rinse.
7. Incorrect voltage coming to the machine. Verify that the voltage matches that on the machine data plate.
8. Wash pump cavitation due to low water level. Verify that the drains are shut and that the water level is correct.

Problem: Spotting of silverware, glasses and dishes.

1. Incorrect final rinse temperature. Verify that the rinse water temperature matches that which is listed on the machine data plate.
2. Clogged wash and/or rinse nozzles and arms. Remove the arms and verify that they and their nozzles are free of debris.
3. Excessively hard water. Install a water softener to reduce hardness.
4. Loss of water pressure due to clogged/obstructed wash pump. Turn the power off to the machine at the source. Drain the wash tank of water and verify that the pump intake is free from debris.
5. Improper scrapping procedures. Review the paragraph entitled "Ware Preparation" in Operating Instructions.
6. incorrect detergent/chemical concentrations. Verify that the detergent/chemical concentrations are correct for the associated water volume.

TORQUE SETTINGS

When replacing components either in the control box or the heater box area, the manufacturer has suggestions on how much to torque the screws and nuts used in securing items to the machine. Refer to the table below for the torque specifications:

<u>ITEMS</u>	<u>TORQUE SPEC</u>
Relays	16 In/lbs
Heater Contactor	35 In/lbs
Heater Nuts	16 In/lbs
Terminal Block	50 In/lbs

SECTION 4: TROUBLESHOOTING

D226 TROUBLESHOOTING SECTION



WARNING: Inspection, testing and repair of electrical equipment should be performed only by qualified service personnel. Certain procedures in this section require electrical tests or measurements while power is applied to the machine. **Exercise extreme caution at all times.** If test points are not easily accessible, disconnect power, attach test equipment and reapply power to test. When replacing electrical parts, disconnect power at source circuit breaker

Problem: Power light does not illuminate.

1. Power not connected to the unit through the control box. Open the control box cover and verify that incoming power lines are connected and light.
2. Service breaker tripped or open. Verify that the breaker is closed.
3. Power switch connections could be loose. Ensure that the connections are of sound quality.
4. Power switch is faulty. Replace the power switch.
5. Power light is faulty. Replace the light.

Problem: Water pressure is too low.

1. Water pressure regulator is out of adjustment. Follow the instructions provided in the maintenance section and adjust so that the flow pressure is 20 ± 5 PSI.
2. Water pressure regulator internal strainer is clogged. Clean in accordance with the instructions provided in the maintenance section.
3. Water pressure regulator is faulty. Replace the regulator.
4. Water pressure gauge is faulty or the cut off from the system. Verify that the test cock valve under the gauge is open to allow for the sensing of line pressure. Replace gauge if necessary.
5. Heat exchanger is clogged. Replace the heat exchanger.

Problem: Solenoid valve is not opening/shutting.

1. Power not connected to the unit through the control box. Open the control box cover and verify that incoming power lines are connected and light.
2. Service breaker tripped or open. Verify that the breaker is closed.
3. Power switch connections could be loose. Ensure that the connections are of sound quality.
4. Power switch is faulty. Replace the power switch.
5. Thermostat is faulty. Replace the thermostat.
6. Solenoid wires are loose or broken. Verify that the electrical connections are of sound quality.
7. Faulty solenoid coil. Replace the solenoid.

Problem: Outlet water temperature too low.

1. Power not connected to the unit through the control box. Open the control box cover and verify that incoming power lines are connected and light.
2. Service breaker tripped or open. Verify that the breaker is closed.
3. Power switch connections could be loose. Ensure that the connections are of sound quality.
4. Power switch is faulty. Replace the power switch.
5. Thermostat is faulty. Replace the thermostat.
6. Solenoid wires are loose or broken. Verify that the electrical connections are of sound quality.
7. Faulty solenoid coil. Replace the solenoid.
8. Steam flow pressure is too low for the unit. Verify that the steam flow is 15-25 PSIG.
9. Water flow pressure is too high. Follow the instructions provided in the maintenance section and adjust so that the flow pressure is 20 ± 5 PSI.
10. Heat exchanger is clogged. Replace the heat exchanger.
11. Insufficient volume of steam to unit. Check the line size and flow pressure.

SECTION 5: SERVICE PROCEDURES

SECTION 5: SERVICE PROCEDURES

REPLACING THE PUMP GASKET & SEAL

These rack conveyor machines come equipped with powerful motors and pumps to ensure ware washing results. Occasionally, some of the parts on these components may need replacing to maintain optimum performance. Two components in particular are the wash pump gasket and the mechanical seal.

The instructions provided here are for maintenance personnel only. Unauthorized persons should not attempt any of the steps contained in these instructions.

Warning: many of the instructions and steps within this document require the use of tools. Only authorized personnel should ever perform any maintenance procedure on the dishmachine!

PREPARATION

1. Power must be secured to the unit at the service breaker. Tag or lock out the service breaker to prevent accidental or unauthorized energizing of the machine.
2. Ensure that incoming water to the machine is secured either by use of a shut-off valve or disconnecting the incoming water line.
3. Ensure that the dishmachine has been completely drained of water and has been allowed to cool down prior to beginning this maintenance procedure.

TOOLS REQUIRED

The following tools will be needed to perform this maintenance evolution:

1. 7/16" socket and ratchet with extension
2. 9/16" socket and ratchet with extension
3. 5/16" Allen wrench
4. 5/16" nutdriver
5. Large flathead screwdriver

TIME REQUIRED

It is estimated that it will take (1) person one and a half hours to perform this task, not including all of the items indicated in the section entitled "PREPARATION".

IMPORTANT NOTES

1. Read these instructions thoroughly before attempting this maintenance procedure. Become familiar with the parts and what actions need to be taken. This will save time in the long run!
2. The procedures demonstrated in this manual are shown being performed on an AJ-44CE rack conveyor dishmachine. The actual maintenance steps, however, apply to any wash, prewash or power rinse motor found on a Jackson rack conveyor dishmachine.

STEPS

1. **Note:** in this procedure, it is not necessary to always remove the wiring from the motor. However, the motor should be treated with the greatest of care when being pulled away and set on the floor for maintenance, as demonstrated in these instructions.
2. Remove the (4) nuts holding the mounting plate in position.



Removing the mounting plate nuts with the 9/16" socket

3. Loosen the band clamp on the back end of the motor.



Loosening the band clamp on the back end of the motor.

4. With the band clamp loosened, carefully remove it from the back end of the motor. Once the clamp is removed, examine it to determine if it needs to be replaced as well. If it is broken in any spots or shows signs of metal fatigue, it is best to order a new one. The purpose of the clamp and the attached support bracket is to keep the weight of the motor from pulling on the tub, damaging it. It is absolutely necessary that this component be replaced once the maintenance procedure is completed.

SECTION 5: SERVICE PROCEDURES

REPLACING THE PUMP GASKET & SEAL (CONTINUED)



Removing the rear clamp

5. Remove the motor support bracket.



Removing the motor support bracket

6. With the motor support bracket removed, gently pull back on the motor. You may have to move it from side to side, but it should start to move back. Pull it completely away from the mounting studs on the tub and set down gently to work on it.

7. Remove the gasket from the tub. If you are going to replace it with a new one, do so at this time. Otherwise, carefully examine the gasket for tears and other damage. If it is acceptable, set to the side. If you are not going to replace the seal, go to step 16.



Removing the pump gasket

8. Using a large screwdriver (flathead preferred, but a phillips-head will work just as well) and the 7/16" socket, loosen and then remove the bolt holding the impeller to motor shaft. Refer to the picture below.



Removing the bolt that holds the impeller to the shaft

9. With the bolt and washer removed, grasp the sides of the impeller and pull up gently. The impeller should slide off of the shaft. Remove the woodruff key as well and set to the side.



Removing the impeller



Removing the woodruff key

SECTION 5: SERVICE PROCEDURES

REPLACING THE PUMP GASKET & SEAL (CONTINUED)

10. Note that the mechanical seal will consist of the following parts:

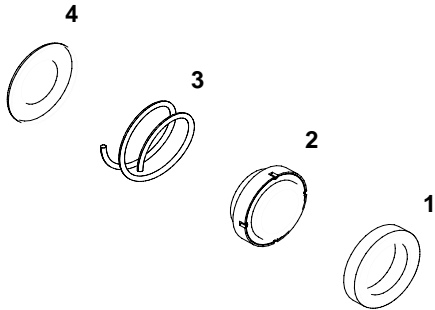

1. A rubber seal with a ceramic ring set inside it that will seat in the center of the mounting plate.

2. A rubber seal with a stainless steel covering on the outside that seals the motor shaft and seats against the ceramic ring.

3. A spring.

4. A stainless steel spring cap to capture the top of the spring and hold it in place.

11. Most of the mechanical seal should simply come off, leaving the rubber seal with the ceramic ring inside the pump mounting plate.

12. Using a screwdriver, pry out the remaining part of the mechanical seal, taking care not to score or damage the motor shaft.

13. Once the hole is free of any parts of the mechanical seal, verify that the hole is clean and free of debris.

14. Gently press the new seal and ceramic over the shaft and slide down into the mounting plate hole. **NOTE:** Do not touch the surface of the seal with your bare fingers; place a rag or paper towel between your fingers and the seal. Gently slide the shaft seal over the shaft and push it down against the mounting plate seal. Place the spring and cap over the shaft.

15. Place the woodruff key back into the groove of the motor shaft and re-install the impeller, being careful to align the woodruff key with the slot in the impeller. Replace the bolt and washer, then tighten.

16. Install the motor by placing it on the studs and sliding it forward until it is against the wash tank wall. Replace the nuts and washers and tighten.

17. Re-install the pump motor support bracket and tighten

down the nuts used to secure it to the tub.

18. Replace the band clamp on the motor and support bracket, tighten until snug.

AFTER MAINTENANCE ACTIONS

Reconnect the incoming water (if disconnected) and turn on. Then restore power to the unit. Run the unit for at least 10 minutes to ensure there are no leaks. If you hear any grinding sounds while the motor is running, immediately shut off the unit and secure power and water. There is a serious problem that must be addressed. If any problems arise you can contact your Jackson representative.

SPECIAL PARTS

Mechanical Seal
06401-003-06-73

Motor Mounting Gasket
06401-003-06-75

Motor Support Clamp
04730-002-32-15

SECTION 5: SERVICE PROCEDURES

RACK RAIL STABILIZER KIT

First, remove three bolts, locknuts and flat washers at middle hood/tub junction.

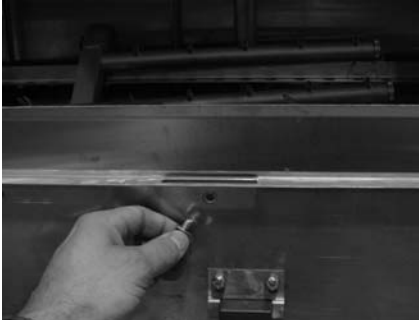

Next, remove door splash shield.



Then, install new door splash shield using the three bolts, locknuts and flat washers.



Rack Rail Stabilizer
05700-011-34-63

SECTION 5: SERVICE PROCEDURES

RINSE SOLENOID VALVE REPAIR PARTS KIT

These dishmachines are equipped with electrical solenoid valves to allow for automatic fill and rinse. These valves are designed to specific tolerances and design aspects that must be met in order to function properly.

Ecolab offers repair kits for replacing some of the wear items associated with solenoid valves which will allow you to save money in that replacement of these parts can take place *without* removing the solenoid valve from the plumbing assembly.

The instructions provided here are for maintenance personnel only. Unauthorized persons should not attempt any of the steps contained in these instructions.

Warning: many of the instructions and steps within this document require the use of tools. Only authorized personnel should ever perform any maintenance procedure on the dishmachine!

PREPARATION

1. Power must be secured to the unit at the service breaker. Tag or lock out the service breaker to prevent accidental or unauthorized energizing of the machine.

2. Ensure that incoming water to the machine is secured either by use of a shut-off valve or disconnecting the incoming water line.

TOOLS REQUIRED

The following tools will be needed to perform this maintenance evolution:

1. Small flathead screwdriver
2. Medium flathead screwdriver
2. Needle nose pliers
3. 5/16" nutdriver
4. Channel locks
5. 12" pipe wrench

TIME REQUIRED

It is estimated that it will take (1) person twenty minutes to perform this task, not including all of the items indicated in the section entitled "PREPARATION".

IMPORTANT NOTES

1. Read these instructions thoroughly before attempting this maintenance evolution. Become familiar with the parts and what actions need to be taken. This will save time in the long run!

2. The procedures demonstrated in this manual are shown being performed on an AJ-44CE rack conveyor dish-machine. The actual maintenance steps, however, apply to any Parker style solenoid valve found on a Jackson dish-machine.

STEPS

1. Remove the top screw with the 5/16" nutdriver. Remove the screw and the data plate and set to the side.



Removing the top screw

2. With the top screw and data plate removed, grasp the solenoid coil and gently pull up. The coil should slide up, allowing you to remove it from the valve bonnet. If you are wanting to replace the coil, continue on with Step 3. If you are wanting to replace some of the internal components of the valve, proceed to step 12.



Removing the coil

3. **NOTE:** Replacing the solenoid coil requires working with the wiring of your machine. It is important that all wiring maintenance be performed by qualified personnel. Always verify the wiring steps presented in this instruction with the schematic that shipped with the unit. A current schematic can also be found in the unit's installation manual. Before beginning any step that involves working with wiring, ensure that the steps located in the section entitled "Preparation" have been performed. Power must be secured to the machine at the service breaker. Failure to do so could result in severe injury to maintenance personnel.

SECTION 5: SERVICE PROCEDURES

RINSE SOLENOID VALVE REPAIR PARTS KIT (CONTINUED)



Prying open the coil wire cover

4. When replacing the coil, ensure that when removing the coil wire cover that care is taken not to damage the wires inside. Using the medium flathead screwdriver, gently use it to open the cover enough to where it could be pulled off.

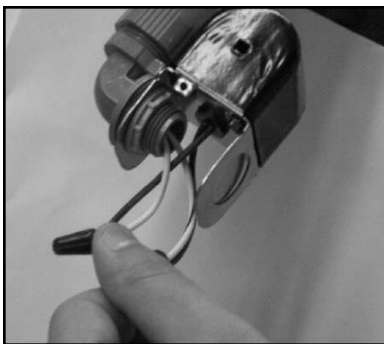

Straightening the wires

5. Once the coil wire cover has been removed and set to the side, take the internal wires and pull them out straight.



Removing the wire nuts

6. Remove the wire nuts from the wires and separate them.



Loosening the conduit nut

7. Using a pair of channel locks, gently loosen the conduit retaining ring for the conduit nut. Once it is loosened, use your fingers to unscrew and remove it.

8. Pull the conduit away and discard the bad coil. Take the new coil and attach the conduit, reinstall & tighten the conduit nut, and pull the wires through so that you will be able to wire the valve back up.

9. Reconnect the wires from the conduit to the wires from the solenoid as they had been connected previously. Ensure that the wire nuts are on tight.

10. Slide the coil wire cover back on, taking care not to damage the wires.

11. If you are done performing maintenance on the valve, continue on to step 23. Otherwise, please go on to step 12.L



Loosening the valve bonnet

12. To remove the valve bonnet, grasp it with the jaws of the pipe wrench and turn to the left. **Note:** on some models you may have to remove the valve in order to perform this and any further steps. Be careful not to damage the plumbing assembly. Only use the pipe wrench enough to where you can spin the valve bonnet off with your hand.

SECTION 5: SERVICE PROCEDURES

RINSE SOLENOID VALVE REPAIR PARTS KIT (CONTINUED)



Removing the valve bonnet

13. Slowly remove the valve bonnet. **Note:** The spring for the plunger is located directly under the bonnet and may come free if you are not careful. Remove the plunger, spring and valve bonnet and place to the side.



Removing the diaphragm

17. Remove the diaphragm retainer and then the diaphragm itself. Many problems associated with a solenoid valve can be traced to a clogged pilot port in the diaphragm.

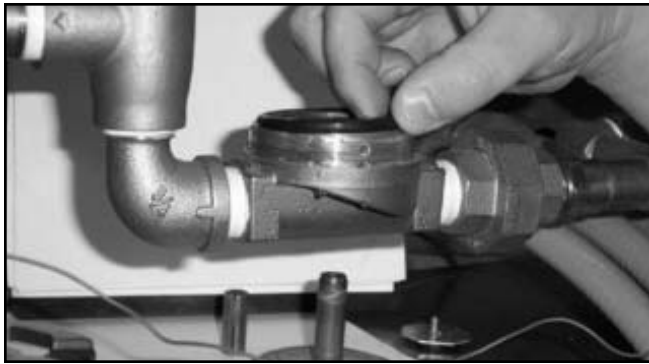

Removing the O-ring

14. Remove the O-ring and inspect it. If it has any tears or cuts or excessive flat spaces, it should be replaced.

15. Examine the threads for the valve bonnet. Check them for scoring or signs of damage. Take a cloth and clean them out to remove any foreign particles that might get lodged in the threads and cause a leak. Severely damaged threads should not be repaired; instead it is recommended that the entire valve should be replaced. These instructions do not provide information on replacing the solenoid valve.

16. **Note:** Even though an O-ring may not appear damaged, it is a good idea to go ahead and replace it if you have a new one. This will help ensure that your valve remains leak-free in the future!



Pointing out the extension hole

18. As indicated in the photo above, the extension hole can become clogged. If it is difficult to clean out, you can use a heated straight pin to push through the hole. The center hole, the pilot port, must also be clear. If the diaphragm is torn or bent in any way, it must be replaced.

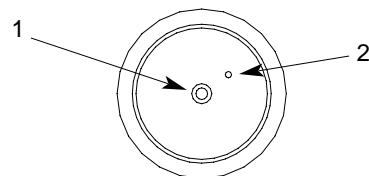

Diaphragm showing (1) pilot port and (2) extension hole

SECTION 5: SERVICE PROCEDURES

RINSE SOLENOID VALVE REPAIR PARTS KIT (CONTINUED)



Removing the screen retainer

19. Using the small flathead screwdriver, lift out the screen retainer. Verify that the holes in it are free of clogs and debris.



Removing the mesh strainer screen

20. Again using the small flathead screwdriver, carefully remove the mesh screen from inside the valve body. The screen should be taken and rinsed out to remove any debris fouling it.



View inside the solenoid valve body

21. With the mesh screen removed, look down into the valve and verify it is not clogged. Remove any foreign objects from the valve body that would obstruct flow.

22. Reassemble the valve, reversing the steps needed to take it apart. Replace defective replacement parts with new parts from ordered kits. Ensure that components are sufficiently tightened to prevent leakage.

AFTER MAINTENANCE ACTIONS

Reconnect the incoming water (if disconnected) and turn on. Then restore power to the unit. Run the unit for at least 10 minutes to ensure there are no leaks. If any problems arise please contact your Jackson representative.

SPECIAL PARTS

Plunger and Spring Replacement Kit
06401-003-07-40

Diaphragm and O-Ring Replacement Kit (3/4")
06401-003-07-42

110V Coil and Housing
06401-003-07-43

SECTION 5: SERVICE PROCEDURES

VACUUM BREAKER REPAIR PARTS KIT

These dishmachines are equipped with vacuum breakers to serve as back-flow prevention devices. ASSE requirements specify what type of back-flow prevention is necessary on dishmachines. Vacuum breakers, unlike air gaps, have certain parts that have specific tolerances and design aspects that must be met in order to function properly.

Ecolab offers repair kits for replacing some of the wear items associated with vacuum breakers which will allow you to save money in that replacement of these parts can take place *without* removing the vacuum breaker from the plumbing assembly.

The instructions provided here are for maintenance personnel only. Unauthorized persons should not attempt any of the steps contained in these instructions.

Warning: many of the instructions and steps within this document require the use of tools. Only authorized personnel should ever perform any maintenance procedure on the dishmachine!

PREPARATION

1. Power must be secured to the unit at the service breaker. Tag or lock out the service breaker to prevent accidental or unauthorized energizing of the machine.

2. Ensure that incoming water to the machine is secured either by use of a shut-off valve or disconnecting the incoming water line.

TOOLS REQUIRED

The following tools will be needed to perform this maintenance evolution:

1. Small flathead screwdriver
2. Needle nose pliers

TIME REQUIRED

It is estimated that it will take (1) person twenty minutes to perform this task, not including all of the items indicated in the section entitled "PREPARATION".

IMPORTANT NOTES

1. Read these instructions thoroughly before attempting this maintenance evolution. Become familiar with the parts and what actions need to be taken. This will save time in the long run!

STEPS

1. **Note:** These instructions only apply to vacuum breakers (1/2" NPT and 3/4" NPT) as pictured below. The repair kits indicated in these instructions will only work on those style of back-flow preventers. If you have a machine with a different style of vacuum breaker, contact your Ecolab representative about replacement components.



Vacuum breaker

2. **Note:** Even though the photos in these instructions show a vacuum breaker that has been removed from the plumbing assembly, these maintenance steps could be performed with it installed so long as the requirements in the section entitled "PREPARATION" have been met.

3. Remove the top cap by gripping firmly and turning to the left. The cap should come off after a few turns.



Removing the cap

4. Set the cap to the side.

5. Using the needle nose pliers, gently lift out the plunger and set to the side. Examine the brass seating surface inside the vacuum breaker. The plunger is required to sit flat on this surface so it must be free of defects, imperfections and the like. If there is debris, remove it. If it is chipped or cracked then the vacuum breaker must be replaced. Failure to do so may result in the vacuum breaker not working according to its design and could result in damage to the dishmachine.

SECTION 5: SERVICE PROCEDURES

VACUUM BREAKER REPAIR PARTS KIT (CONTINUED)



Removing the plunger

6. Your repair kit comes with a new plunger. Examine the old one and ensure that the mating surface is not damaged or cut. Also inspect the rubber seal on the top of the plunger to ensure it is in good condition and not torn.

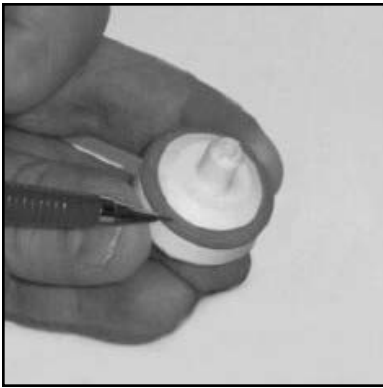

Examining the seal ring on the plunger

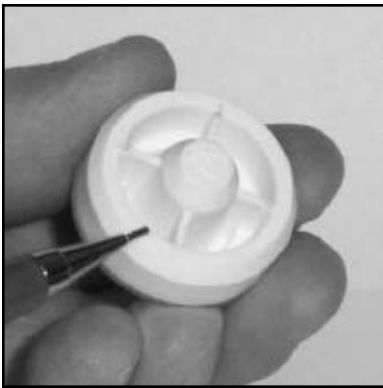

Examining the plunger seating surface

7. If any of these conditions are present, replace the old plunger with the new one from your kit. Verify that the new plunger is also free from defects. If it is not, contact your Ecolab representative immediately.

8. The plunger should drop into the vacuum breaker and seat. Ensure it is not flipped upside down (the orange seal ring should be up towards the top of the vacuum breaker).

9. Pick up the cap and examine it. With a soft towel, remove any grit, grime or debris that may have gotten caught in the threads of both the cap retainer or the vacuum breaker body. There is an O-ring that should be present on the cap retainer as well. Regardless of the condition of the plunger, this O-ring should be replaced once the cap is removed. Using a small flathead screwdriver, remove the old O-ring.

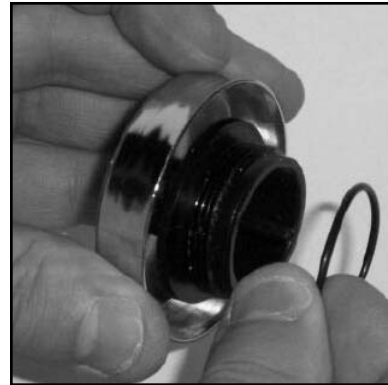

Replacing the O-ring

10. With the new O-ring in place, screw the cap back on the vacuum breaker body. The cap needs to only be hand tight (snug).

AFTER MAINTENANCE ACTIONS

1. Reconnect the incoming water (if disconnected) and turn on. Then restore power to the unit. Run the unit for at least 10 minutes to ensure there are no leaks. If any problems arise please contact your Jackson representative.

SPECIAL PARTS

To order the kit with components and instructions:

Components of 1/2" Repair Kit
06401-003-06-23

Components of 3/4" Repair Kit
06401-003-06-24

SECTION 5: SERVICE PROCEDURES

DRIVE MOTOR/GEAR REDUCER REPLACEMENT

The drive motor and the gear reducer of your Jackson rack conveyor are responsible for moving racks of ware through the dishmachine. If needed to be replaced, these instructions will show you how to get your machine up and running in the shortest possible time.

Jackson offers all of the repair parts necessary for performing this task.

The instructions provided here are for maintenance personnel only. Unauthorized persons should not attempt any of the steps contained in these instructions.

Warning: many of the instructions and steps within this document require the use of tools. Only authorized personnel should ever perform any maintenance procedure on the dishmachine!

PREPARATION

1. Power must be turned off to the unit at the service breaker. Tag or lock out the service breaker to prevent accidental or unauthorized energizing of the machine.

TOOLS REQUIRED

The following tools will be needed to perform this maintenance evolution:

1. 7/16" socket and ratchet with extension
2. 9/16" socket and ratchet with extension
3. 7/16" combination wrench
4. 9/16" combination wrench
5. 3/4" combination wrench
6. 1/8" Allen wrench
7. 1/4" nutdriver
8. Large flathead screwdriver
9. Medium phillipshead screwdriver
10. Medium hammer
11. Rubber mallet

TIME REQUIRED

It is estimated that it will take (1) person one and a quarter hours to replace the drive motor, one and a quarter hours to just replace the gear reducer or two hours to do both at one time, not including all of the items indicated in the section entitled "PREPARATION".

IMPORTANT NOTES

1. Read these instructions thoroughly before attempting this maintenance procedure. Become familiar with the parts and what actions need to be taken. This will save time in the long run!

2. The procedures demonstrated in this manual are shown being performed on an AJ-44 rack conveyor dishma-

chine. The actual maintenance steps, however, apply to any drive motor or gear reducer found on a Jackson rack conveyor or dishmachine.

STEPS

1. Remove the (2) screws that secure the top drive assembly cover in place.

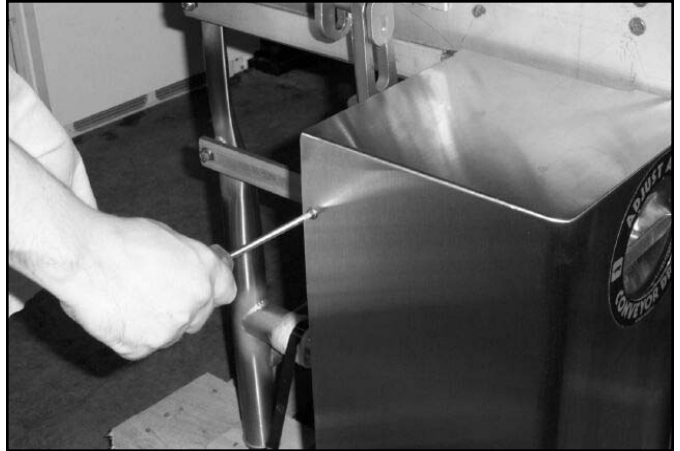

Removing the screws from the top cover.

2. Remove the top cover to expose the drive assembly.



Removing the top cover.

3. Set the top cover to the side and out of the way so that it does not become a trip hazard. From here, the next step will be to remove the bottom cover. This will require using the 7/16" socket with ratchet and most likely the 7/16" combination wrench. Do not lose the hardware for the covers as your repair kits do not come with the hardware necessary to replace these. If you do require hardware that is not present in your kits, do not hesitate to contact Jackson Technical Service for help.

SECTION 5: SERVICE PROCEDURES

DRIVE MOTOR/GEAR REDUCER REPLACEMENT (CONTINUED)



Removing the nuts securing the bottom cover.



Removing the bottom cover.

4. Remove the bottom and set to the side so that it does not become a trip hazard.



Removing the bolts holding the drive motor to the gear reducer.

5. With the cover removed you may now remove the bolts used to connect the drive motor to the gear reducer. **Note:** you need to support the motor as you remove the bolts; failure to do so could result in the motor falling to the ground and becoming damaged.



Removing the drive motor.

6. Once the bolts are removed, the motor should slide out of the gear reducer. Remember to support and lay it gently on the floor or some other surface in order to continue working on it. Be sure that you get the key, checking the keyway on the motor shaft and in the gear reducer.

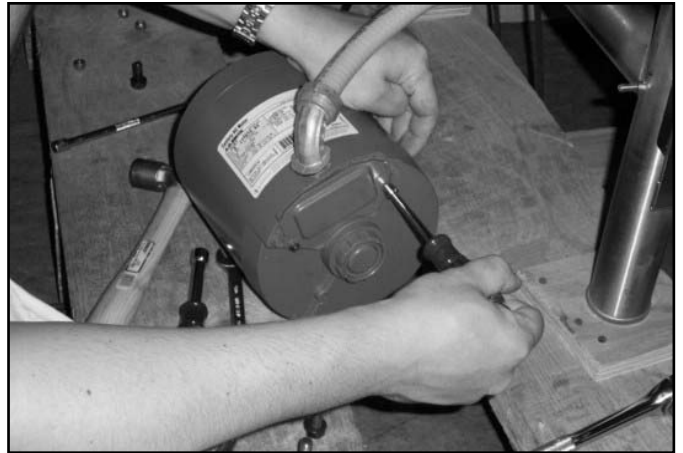

Removing the wiring access cover.

7. If the purpose of this maintenance action is to replace the drive motor, continue to step 8. If you wish to replace the gear reducer, continue to step 21.

8. With the motor laying on a level surface, you need to remove the conduit from it. First, use the 1/4" nutdriver to remove the wiring access cover on the back of the motor.

9. Once the cover is removed and the wiring is exposed, you

SECTION 5: SERVICE PROCEDURES

DRIVE MOTOR/GEAR REDUCER REPLACEMENT (CONTINUED)

may want to jot down how your motor is wired. You can also refer to the schematic located on the motor itself because how the motor is wired when you remove it is how you will wire it when you replace it. If you have any questions regarding the wiring of your motor, do not hesitate to contact Jackson Technical Service.

reducer and assemble the two components continue on to step 27.



Removing the wire nuts.

10. pull the bundled wires out and remove the wire nuts. Set the wire nuts to the side as you will need them when you wire up the new motor.

11. Once the wire nuts are removed, separate the wires.

12. With the flathead screwdriver and the hammer, loosen the conduit nut. Once loosened, pull the conduit away from the motor. The motor may now be disposed of.

13. Remove the access cover off of the new motor.

14. Attach the conduit and pull the wires through the hole provided. Tighten the conduit nut.

15. Using the wire nuts, wire the motor back the same way the old one had been. Refer to the schematic on the motor itself or contact Jackson Technical Service if you any questions.

16. Once the wiring is done, carefully push wires back into the motor and put the access cover back on. Tighten down the screws for securing it.

17. The drive motor now needs to be reattached to the gear reducer. There are two methods for doing this. The first is to try and and reinsert the drive motor shaft into the gear reducer with it (gear reducer) still attached to the unit. This is difficult but possible. Ensure that the key is in the keyway when you mate the parts. The second method and perhaps the easiest is to remove the gear reducer, mate the two parts and bolt them together and then put them on the unit at one time. This method takes a little more time. If you wish to remove the gear



The WRONG way to mount the drive motor.



The Correct way to mount the drive motor.

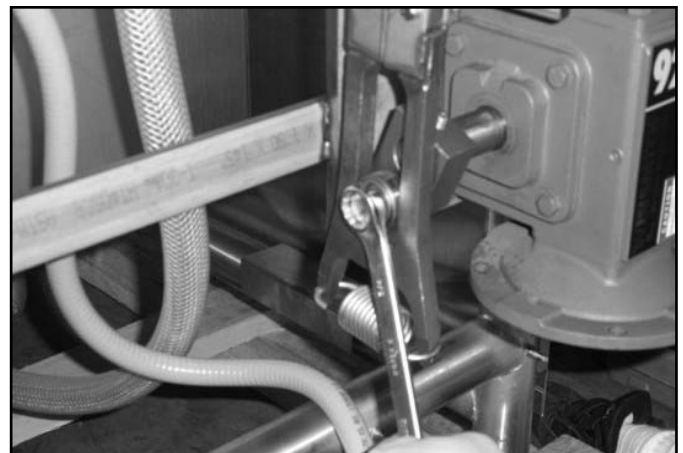

Removing the drive hub bolt.

SECTION 5: SERVICE PROCEDURES

DRIVE MOTOR/GEAR REDUCER REPLACEMENT (CONTINUED)

18. Once the motor and gear reducer are mated, secure them with the locknuts and bolts. Ensure the bolts are tight.



Loosening the set screw with the 1/8 allen wrench.

Note: Because of the way the covers for the drive assembly are designed, it is imperative that you position the motor on the gear reducer so that the conduit fitting is facing towards the front of the dishmachine. If it is facing away from the machine, the covers may not go back on.

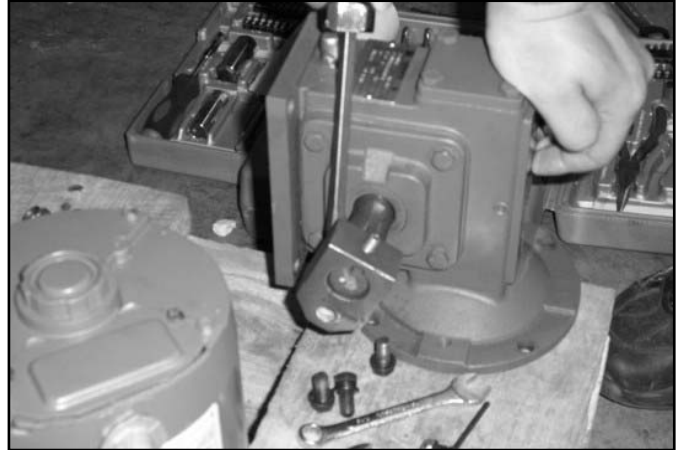

Removing the drive hub.

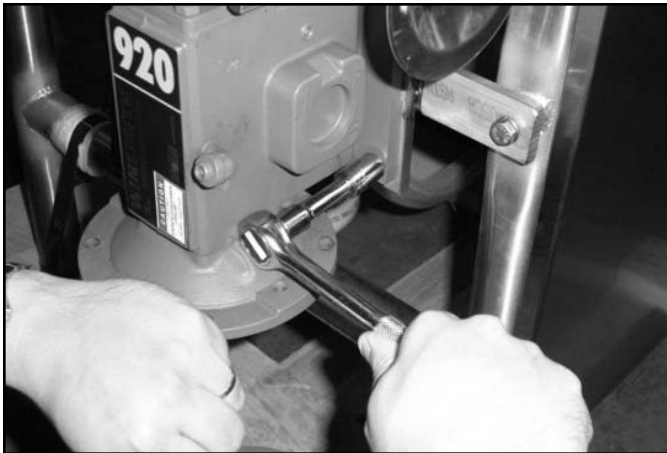

Removing the nuts holding the gear reducer on.

19. Reattach the bottom and top drive assembly covers.

20. Proceed to the sections entitled "AFTER MAINTENANCE ACTIONS".

21. (Continuing from step 7) To remove the gear reducer, first take the 3/4" combination wrench and remove the drive hub bolt.

22. Once the drive hub bolt & bearing are removed, loosen the set screw on the drive hub. There is no need to remove it.

23. Remove the gear drive by using the 9/16" socket and ratchet, as well as the combination wrench as required, to remove the nuts holding it to the mounting plate.

24. Gently remove the gear reducer, careful not to drop it.

25. Set the gear reducer on a flat surface. The drive hub needs to be removed. You have already loosened the set screw, but it may take some more effort to remove it. You may have pry it off, or give it some taps with a mallet to coax it off of the shaft. The liberal use of spray lubricants will also help.

26. Once the drive hub is removed, place it on the shaft of the new gear reducer. Ensure the key is in the keyway. Once it is on and flush with the end of the shaft, tighten down on the set screw with the 1/8" allen wrench.



Removing the gear reducer.

SECTION 5: SERVICE PROCEDURES

DRIVE MOTOR/GEAR REDUCER REPLACEMENT (CONTINUED)

27. As you have both the drive motor and the gear reducer off of the machine, it is much simpler to assemble them together prior to mounting them. Ensuring that the key for the drive shaft of the drive motor is in the keyway.

28. After the motor is mated against the gear reducer, turn the motor so that the conduit fitting will face towards the front of the dishmachine once both components are mounted to the frame. This is to all the drive assembly covers to go back on. If you do not do this, then there is a possibility the covers will not fit back on the unit. Refer to step 18 and the note following for more details.

29. Stand the assembly up and secure them using the lockwashers and bolts. Use the 9/16" combination wrench to tighten them down.



Mounting the motor to the gear reducer.



Tightening the bolts to secure the drive motor to the gear reducer.

30. Once the motor is securely fastened to the gear reducer, carefully lift the assembly up and mount it on the fasteners. Be

sure to use proper lifting techniques to prevent injury.

31. Once mounted, secure with the lockwashers and locknuts.

32. Reinstall the drive hub bearing and drive hub bolt, tightening down with the 7/8" combination wrench.

33. Reattach the bottom and top assembly covers.

AFTER MAINTENANCE ACTIONS

Reconnect the incoming water (if disconnected) and turn on. Then restore power to the unit. Run the unit for at least 10 minutes, running an empty rack through the machine to ensure that it is carried all of the way through. If you hear any grinding sounds while the motor is running, immediately shut off the unit and secure power and water. There is a serious problem that must be addressed. If any problems arise you can contact Jackson Technical Service.

SPECIAL NOTES

Work performed on Jackson dishmachines by unauthorized or unqualified personnel may void the warranty. Before beginning this or any other maintenance evolution on a unit under warranty, you should contact a certified Jackson technician or Jackson Technical Service. You can find a list of qualified service agencies in the back of you unit's installation manual.

SPECIAL PARTS

AJ-54/76/70 Machines:

Gear Reducer: 06105-011-71-88

Drive Motor Replacement Kit:

50 Hz: 06401-003-08-41

60Hz/1 Ph: 06401-003-08-42

60 Hz/3 Ph: 06401-003-08-40

600V/60 Hz/3 Ph: 06401-003-08-43

CONTACT INFORMATION

Jackson MSC Inc. provides technical support for all of the dishmachines detailed in this manual. We strongly recommend that you refer to this manual before making a call to our technical support staff. Please have this manual with you when you call so that our staff can refer you, if necessary, to the proper page. Technical support is available from 8:00 a.m. to 5:00 p.m. (EST), Monday through Friday. Technical support is not available on holidays. Contact technical support toll free at 1-888-800-5672.

SECTION 5: SERVICE PROCEDURES

REPLACING THE WASH HEATER

Jackson rack conveyor machines come equipped with heaters to ensure proper ware washing results. Occasionally, some of these components may need replacing to maintain optimum performance.

Jackson offers all of the repair parts necessary for performing this task.

The instructions provided here are for maintenance personnel only. Unauthorized persons should not attempt any of the steps contained in these instructions.

Warning: many of the instructions and steps within this document require the use of tools. Only authorized personnel should ever perform any maintenance procedure on the dishmachine!

PREPARATION

1. Power must be secured to the unit at the service breaker. Tag or lock out the service breaker to prevent accidental or unauthorized energizing of the machine.
2. Ensure that incoming water to the machine is secured either by use of a shut-off valve or disconnecting the incoming water line.
3. The unit must be drained completely.

TOOLS REQUIRED

The following tools will be needed to perform this maintenance evolution:

1. 3/8" Nutdriver
2. Ratchet
3. 1/2" Socket
4. 3/8" Socket
5. Phillipshead Screwdriver
6. Needlenose Pliers
7. Torque Wrench
8. Silicone Sealant
9. Amp Meter

TIME REQUIRED

It is estimated that it will take (1) person ninety minutes to perform this task, not including all of the items indicated in the section entitled "PREPARATION".

IMPORTANT NOTES

1. Read these instructions thoroughly before attempting this maintenance task. Become familiar with the parts and what actions need to be taken. This will save time in the long run!

STEPS

1. Remove the front dress panel.
2. Remove the heater box cover to expose the heater. Set the cover and hardware to the side.



Removing the power lines.

3. Remove the incoming electrical lines from the heater. Set the hardware to the side.

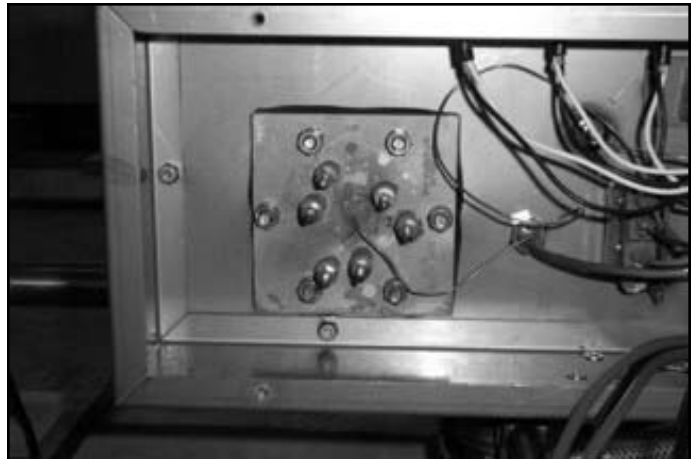

Heater without power lines attached.

4. Push the incoming electrical lines out of the way.
5. The thermostat probe needs to be removed from the well inside the heater. The probe is secured in place with silicone that must be peeled away prior to attempting to remove it. It is important that you do not damage the probe during this part of the maintenance action. If you do, then the thermostat will have to be replaced as well.

SECTION 5: SERVICE PROCEDURES

REPLACING THE WASH HEATER (CONTINUED)



Removing silicone from thermostat well

6. Using your hand or needlenose pliers, remove the silicone so that the thermostat probe may be gently removed.



Removing the nuts and lockwashers



Removing the heater



Removing the gasket

7. With the thermostat probe out of the way, use the 1/2" socket and ratchet to remove the nuts holding the heater to the tub. Remove all nuts and lockwashers.

8. Remove the heater from the tub weldment.

9. Remove the gasket.



Applying the torque wrench to the nuts

10. Before proceeding any further, it is important to verify that the tub wall is free of any excess debris so that when the new gasket is applied, there are no gaps that could lead to leaking around the heater.

11. Apply the new heater gasket from your service kit.

12. Slide the heater onto the studs and apply by hand the lockwashers and nuts. Tighten the nuts by hand and then use the torque wrench set to 154 in-lbs to ensure that the nuts are secure.

SECTION 5: SERVICE PROCEDURES

REPLACING THE WASH HEATER (CONTINUED)



Putting the thermostat probe in the heater well

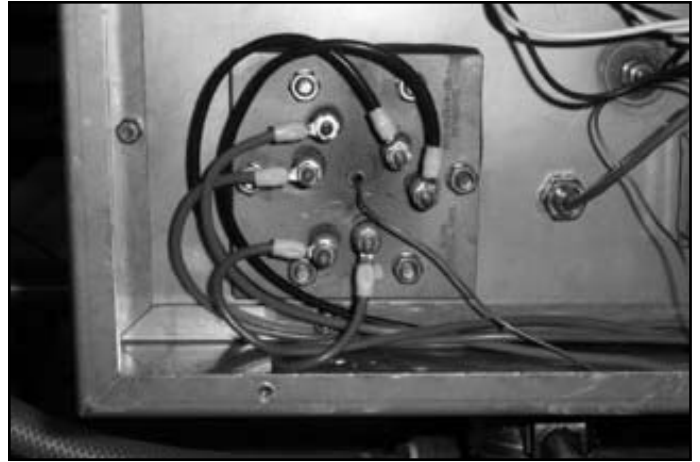

Three phase wiring



Applying silicone to the heater well

13. The thermostat probe needs to be placed into the well of the new heater. Again, use caution when doing this so that the probe or the capillary tube do not become broken. If this occurs, then the thermostat will have to be replaced.

14. Apply silicone to seal the well and hold the thermostat probe in place.

15. Reattach the incoming power lines to the heater, ensuring that you wire the heater correctly for either single or three



phase operation
tightening the nuts holding the power lines

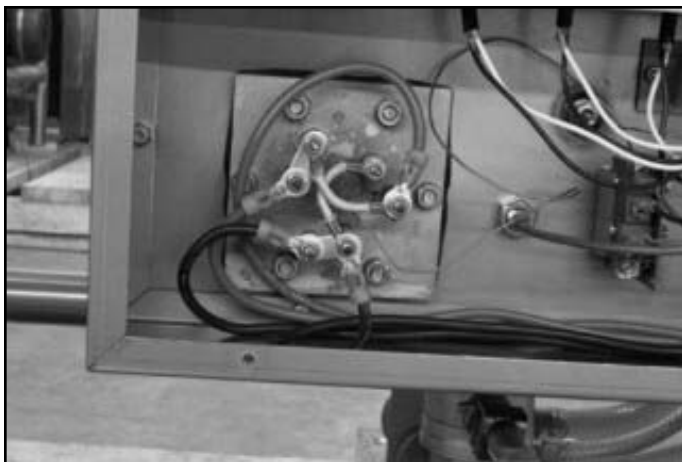

Single phase wiring

16. Using the torque wrench or a torque nutdriver (if available) torque the nuts holding the wires, jumpers and bus bars to 16 in-lbs.

17. Ensuring that all non-essential personnel are clear of the area, close the drain valve(s) and restore power and water to

SECTION 5: SERVICE PROCEDURES

REPLACING THE WASH HEATER (CONTINUED)

the unit. Turn the unit on and allow it to fill normally.

18. Verify that there are no leaks around the heater. If there are, attempt to tighten it down as the tub will change shape slightly as it heats up.

19. Use the amp meter to take readings off of the power lines to the heater, verifying the amperage draw to the machine data plate.

20. Wait until the heater contactor kicks out (meaning that the tub has reached the appropriate temperature) and place the unit in DELIME mode by flipping the switch on the back of the control box. Allow the unit to operate for at least ten minutes to verify that there are no leaks and that the heater is maintaining the tank temperature.

21. If the unit appears to be operating correctly, return it to AUTO mode and turn off.

22. Replace the heater box cover.

23. Replace the front dress panel.

AFTER MAINTENANCE ACTIONS

Service personnel may want to drain the machine and allow it to cool down. Secure power to the unit at the service breaker and then verify the torque of all fasteners covered in this instruction.

SPECIAL NOTES

Work performed on Jackson dishmachines by unauthorized or unqualified personnel may void the warranty. Before beginning this or any other maintenance evolution on a unit under warranty, you should contact a certified Jackson technician or Jackson Technical Service. You can find a list of qualified service agencies in the back of your unit's installation manual.

SPECIAL PARTS

Heater Replacement Kit Chart

<u>Model</u>	<u>Volts</u>	<u>Phase</u>	<u>KW</u>	<u>Part Number</u>
ALL	208	1	10	06401-003-12-94
	230	1	10	06401-003-12-95
	200	3	10	06401-003-12-94
	208	3	10	06401-003-12-94
	230	3	10	06401-003-12-95
	460	3	10	06401-003-12-96
	575	3	10	06401-003-12-97
	600	3	10	06401-003-12-97

CONTACT INFORMATION

Jackson MSC Inc. provides technical support for all of the dishmachines detailed in this manual. We strongly recommend that you refer to this manual before making a call to our technical support staff. Please have this manual with you when you call so that our staff can refer you, if necessary, to the proper page. Technical support is available from 8:00 a.m. to 5:00 p.m. (EST), Monday through Friday. Technical support is not available on holidays. Contact technical support toll free at 1-888-800-5672. Please remember that technical support is available for service personnel only.

SECTION 5: SERVICE PROCEDURES

REPLACING CONVEYOR MOTOR

The instructions provided here are for maintenance personnel only. Unauthorized persons should not attempt any of the steps contained in these instructions.

Warning: many of the instructions and steps within this document require the use of tools. Only authorized personnel should ever perform any maintenance procedure on the dishmachine!

PREPARATION

1. Power must be secured to the unit at the service breaker. Tag or lock out the service breaker to prevent accidental or unauthorized energizing of the machine.
2. Ensure that incoming water to the machine is secured either by use of a shut-off valve or disconnecting the incoming water line.
3. Ensure that the dishmachine has been completely drained of water and has been allowed to cool down prior to beginning this maintenance procedure.

TOOLS REQUIRED

The following tools will be needed to perform this maintenance evolution:

1. 7/16" socket and ratchet with extension
2. 9/16" socket and ratchet with extension
3. 5/16" Allen wrench
4. 5/16" nutdriver
5. Large flathead screwdriver
6. Small flathead screwdriver

TIME REQUIRED

It is estimated that it will take (1) person one and a half hours to perform this task, not including all of the items indicated in the section entitled "PREPARATION".

IMPORTANT NOTES

1. Read these instructions thoroughly before attempting this maintenance procedure. Become familiar with the parts and what actions need to be taken. This will save time in the long run!
2. The procedures demonstrated in this manual are shown being performed on an AJ-44 rack conveyor dishmachine. The actual maintenance steps, however, apply to any wash, prewash or power rinse motor found on a Jackson rack conveyor dishmachine.
3. These basic instructions will apply to all prewash, wash and power rinse motors found on AJ, TS and TSC series machines.

STEPS

1. Remove the (4) nuts holding the mounting plate in position.



Removing the mounting plate nuts with the 9/16" socket

2. Loosen the band clamp on the back end of the motor.

3. With the band clamp loosened, carefully remove it from the back end of the motor. Once the clamp is removed, examine it to determine if it needs to be replaced as well. If it is broken in any spots or shows signs of metal fatigue, it is best to order a new one. The purpose of the clamp and the attached support bracket is to keep the weight of the motor from pulling on the tub, damaging it. It is absolutely necessary that this component be replaced once the maintenance procedure is completed.



Loosening the band clamp on the back end of the motor.

SECTION 5: SERVICE PROCEDURES

REPLACING CONVEYOR MOTOR



Removing the rear clamp



Removing the pump gasket

4. Remove the motor support bracket.



Removing the motor support bracket

5. With the motor support bracket removed, gently pull back on the motor. You may have to move it from side to side, but it should start to move back. Pull it completely away from the mounting studs on the tub and set down gently to work on it.

6. Remove the gasket from the tub.

7. Use a screwdriver to remove the wiring cover from the motor wiring box. Take note of how the motor is wired up because you will have to wire it up the exact same way when you install the new motor.

8. Remove the conduit fitting from the motor wiring box.

9. Pull the conduit away from the motor and set old motor to the side. Dispose of the old motor in accordance with warranty or national/state/local guidelines, whichever may apply.

10. Remove the wiring cover on the new motor assembly and pull the wires free. Install the conduit fitting.

11. Run the conduit to the motor, pulling the machine wires through and into the motor wiring box.

12. Rewire the motor exactly the same way the old one was wired and/or refer to the motor schematic to determine how the motor should be wired for the incoming power. If you require help on this, do not hesitate to contact Jackson Technical Service. Ensure that all wiring is done in accordance with national, state and local codes as applicable.



Re-mounting the wash motor assembly

13. Place the new motor gasket on the tub over the mounting studs.

14. Carefully lift the motor assembly and slide it onto the mounting studs.

15. Re-install the mounting hardware and tighten down.

SECTION 5: SERVICE PROCEDURES

REPLACING CONVEYOR MOTOR

16. Attach the motor support rear clamp.
17. Adjust the motor support bracket so that the motor assembly is level and tighten down.
18. Attach the motor wiring cover.

AFTER MAINTENANCE ACTIONS

Reconnect the incoming water (if disconnected) and turn on. Then restore power to the unit. Run the unit for at least 10 minutes to ensure there are no leaks. If you hear any grinding sounds while the motor is running, immediately shut off the unit and secure power and water. There is a serious problem that must be addressed. If any problems arise you can contact Jackson Technical Service.

SPECIAL PARTS

Bracket, Motor Support
05700-021-73-42

Clamp, Motor Support
04730-002-32-15

CONTACT INFORMATION

Jackson MSC Inc. provides technical support for all of the dishmachines detailed in this manual. We strongly recommend that you refer to this manual before making a call to our technical support staff. Please have this manual with you when you call so that our staff can refer you, if necessary, to the proper page. Technical support is available from 8:00 a.m. to 5:00 p.m. (EST), Monday through Friday. Technical support is not available on holidays. Contact technical support toll free at 1-888-800-5672. Please remember that technical support is available for service personnel only.

SECTION 6: PARTS SECTION

SECTION 6: PARTS SECTION

AJ-54 CONTROL BOX ASSEMBLY

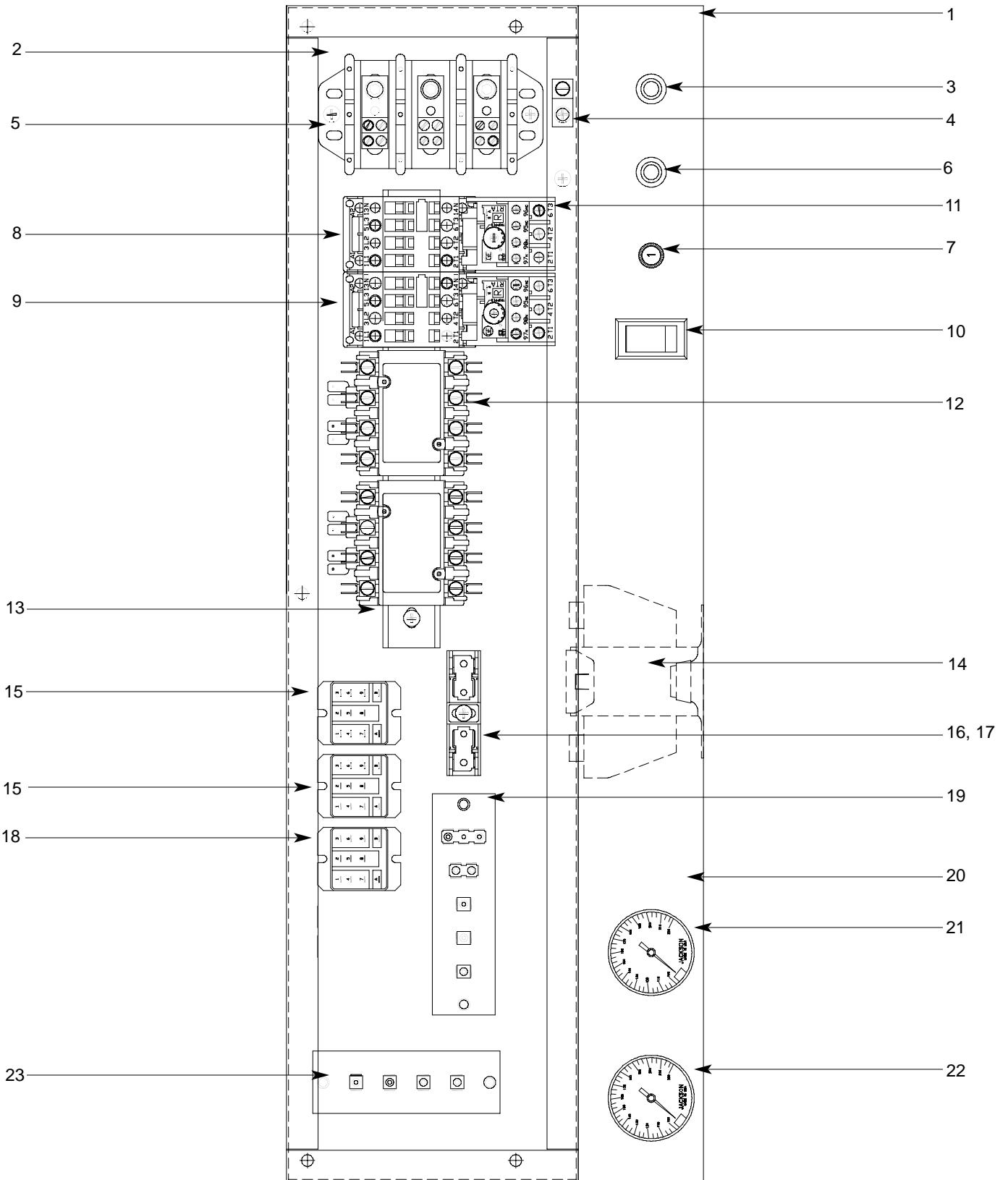

SECTION 6: PARTS SECTION
AJ-54 CONTROL BOX ASSEMBLY (CONTINUED)

ITEM	QTY	DESCRIPTION	Mfg. No.
1	1	Electrical Box Weldment	05700-041-88-43
2	1	Electrical Plate	05700-031-67-03
3	1	Light, Amber	05945-111-44-44
4	1	Ground Lug	05940-200-76-00
5	1	Terminal Block	05940-011-48-27
6	1	Light, Red	05945-111-44-45
7	1	Circuit Breaker (208 & 230 Volt Models Only)	05925-011-68-34
8	1	Motor Contactor	05945-111-68-38
9	1	Motor Contactor	05945-111-68-38
10	1	Switch, Manual Wash	05930-301-46-00
11	1	Overload	See Chart
12	2	Heater Contactor (Electrically-Heated Models Only)	05945-002-24-70
13	1	Din Rail, 5-3/4" Long	05700-021-72-75
14	1	Transformer	05950-011-68-35
	1	Transformer (575/600 Volt Models Only)	05950-002-23-77
15	2	Relay, Top Mount	05945-111-72-51
16	1	Fuse Holder (460/575/600 Volt Models Only)	05920-011-72-89
17	1	Fuse (460/575/600 Volt Models Only)	05920-011-72-88
18	1	Control Relay	05945-111-35-19
19	1	Terminal Board	05940-021-70-70
20	1	Control Box Decal	09905-021-72-29
21	1	Thermometer, Wash	06685-111-68-48
	1	Decal, Wash 160°F	09905-003-00-69
22	1	Thermometer, Rinse	06685-111-68-49
	1	Decal, Rinse 180°F	09905-002-97-62
23	1	Terminal Board, Screw Down	05940-021-89-41

Items not shown:

Grommet, 1/2" OD x 3/8" ID	05325-011-46-73
Bushing, Heyco SB100	05975-210-09-00
Plug, Heyco 2700 G-875	05975-011-47-81
Control Box Cover	05700-031-66-88
Control Box Cover Hinge Weldment	05700-021-68-57
Control Hinge Rod	05700-011-68-58
MANUAL/DELIME Switch (Located on rear of control box)	05930-301-22-18
MANUAL/DELIME Decal	09905-011-74-61
Copper Conductors Only Decal	09905-011-47-35
Control Box Leg	05700-011-71-47

SECTION 6: PARTS SECTION

AJ-76 & AJ-90 CONTROL BOX ASSEMBLY

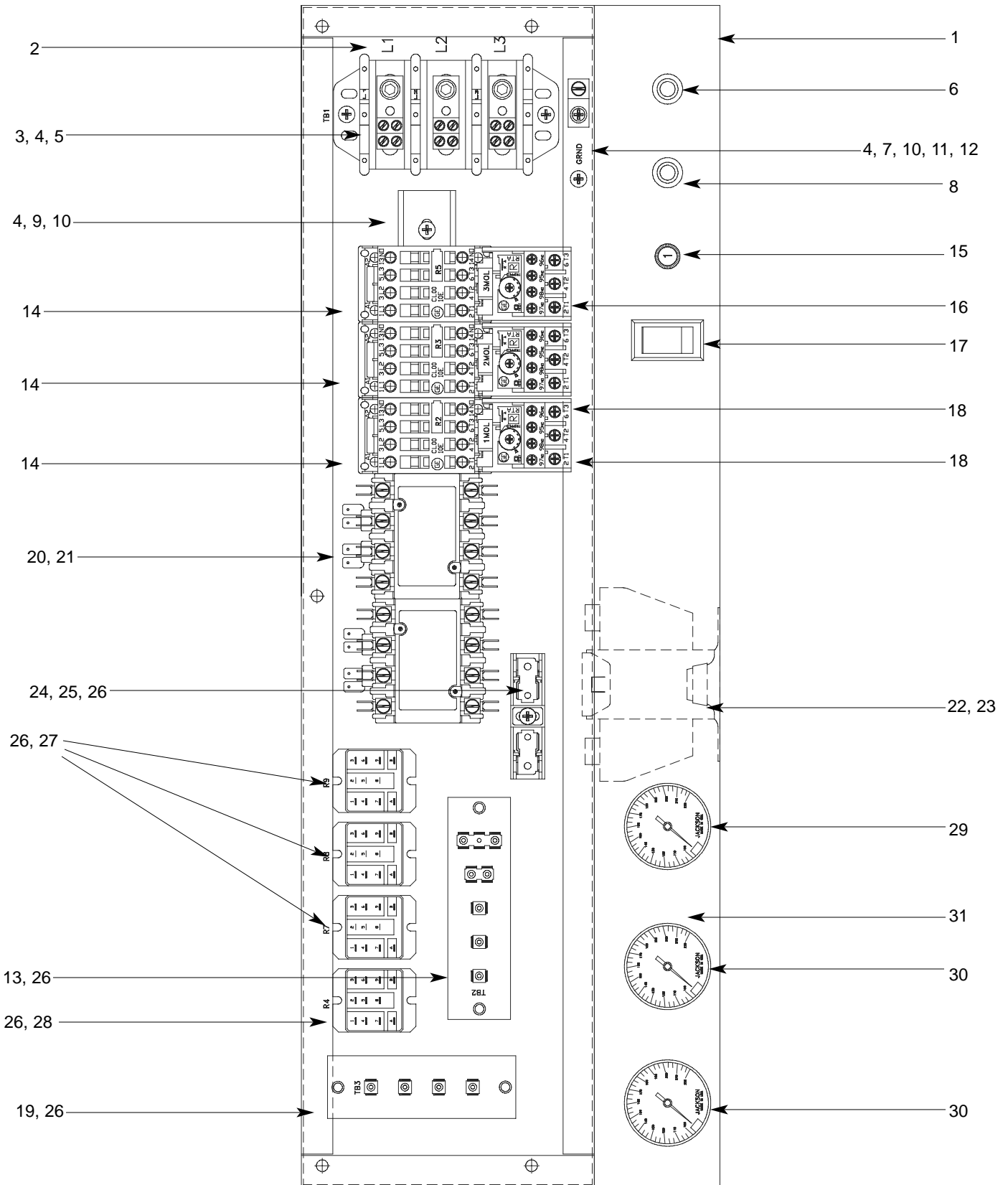

SECTION 6: PARTS SECTION

AJ-76 & AJ-90 CONTROL BOX ASSEMBLY (CONTINUED)

ITEM	QTY	DESCRIPTION	Mfg. No.
1	1	Electrical Box Weldment	05700-041-88-50
2	1	Decal, L1-L2-L3	09905-101-12-66
3	1	Terminal Block	05940-011-48-27
4	6	Lockwasher, #10	05311-273-02-00
5	2	Screw, 10-32 x 3/4" Long Phillips Trusshead	05305-011-62-17
6	1	Light, Amber	05945-111-44-44
7	1	Wire Lug, 2 AWG to 14 AWG	05940-200-76-00
8	1	Light, Red	05945-111-44-45
9	1	Din Rail	05700-021-94-96
10	3	Screw, 10-32 x 1/2" Long Phillips Trusshead	05305-011-39-36
11	1	Washer, Flat, 1/4"	05311-174-01-00
12	1	Decal, Ground	09905-011-86-86
13	1	Terminal Board	05940-021-70-70
14	3	Motor Contactor	05945-111-68-38
15	1	Circuit Breaker (208 & 230 Volt Models Only)	05925-011-68-34
16	1	See Motor Overloads Chart	N/A
17	1	Switch, ON/FILL & OFF/DRAIN	05930-011-49-55
18	1	See Motor Overloads Chart	N/A
19	1	Terminal Board	05940-021-89-41
20	2	Heater Contactor (Not Available on Steam Models)	05945-002-24-70
21	2	Screw, 10-32 x 3/8" Long Phillips Trusshead	05305-173-12-00
22	1	Transformer	05950-011-68-35
	1	Transformer (575/600 Volt Models Only)	05950-002-23-77
23	4	Locknut, 10-24 with Nylon Insert	05310-373-01-00
24	1	Fuse Holder (460/575/600 Volt Models Only)	05920-011-72-89
25	1	Fuse (460/575/600 Volt Models Only)	05920-011-72-88
26	12	Screw, 6-32 x 3/8" Long Phillipshead	05305-171-02-00
27	3	Control Relay	05945-111-35-19
28	1	Relay	05945-111-72-51
29	1	Thermometer, Prewash	06685-111-68-49
30	2	Thermometer, Rinse/Wash	06685-111-87-13
	1	Decal, Wash 160°F	09905-003-00-69
	1	Decal, Rinse 180°F	09905-002-97-62
31	1	Decal, Gauge	09905-021-72-30

Items not shown:

Grommet, 1/2" OD x 3/8" ID	05325-011-46-73
Bushing, Heyco SB100	05975-210-09-00
Plug, Heyco 2700 G-875	05975-011-47-81
Control Box Cover	05700-031-66-88
Control Box Cover Hinge Weldment	05700-021-68-57
Control Hinge Rod	05700-011-68-58
MANUAL/DELIME Switch (Located on rear of control box)	05930-301-22-18
MANUAL/DELIME Decal	09905-011-74-61
Copper Conductors Only Decal	09905-011-47-35
Control Box Leg	05700-011-71-47

SECTION 6: PARTS SECTION**MOTOR OVERLOADS**

<u>Model</u>	<u>Volts</u>	<u>Hz</u>	<u>Phase</u>	<u>Drive Motor</u>	<u>Prewash Motor</u>	<u>Wash Motor</u>
AJ-54CE	208	60	1	N/A	N/A	N/A
AJ-54CE	230	60	1	N/A	N/A	N/A
AJ-54CE	208	60	3	05945-111-68-39	N/A	05945-111-68-40
AJ-54CE	230	60	3	05945-111-68-39	N/A	05945-111-68-40
AJ-54CE	460	60	3	05945-111-68-39	N/A	05945-111-68-40
AJ-54CE	575	60	3	05945-111-69-12	N/A	05945-111-68-41
AJ-54CE	600	60	3	05945-111-69-12	N/A	05945-111-81-33
AJ-54CS	208	60	1	N/A	N/A	N/A
AJ-54CS	230	60	1	N/A	N/A	N/A
AJ-54CS	208	60	3	05945-111-68-39	N/A	05945-111-68-40
AJ-54CS	230	60	3	05945-111-68-39	N/A	05945-111-68-40
AJ-54CS	460	60	3	05945-111-68-39	N/A	05945-111-68-40
AJ-54CS	575	60	3	05945-111-69-12	N/A	05945-111-68-41
AJ-54CS	600	60	3	05945-111-69-12	N/A	05945-111-81-33
AJ-76CE	208	60	1	N/A	N/A	N/A
AJ-76CE	230	60	1	N/A	N/A	N/A
AJ-76CE	208	60	3	05945-111-68-39	05945-111-68-41	05945-111-68-40
AJ-76CE	230	60	3	05945-111-68-39	05945-111-68-41	05945-111-68-40
AJ-76CE	460	60	3	05945-111-68-39	05945-111-68-41	05945-111-68-40
AJ-76CE	575	60	3	05945-111-69-12	05945-111-68-41	05945-111-68-41
AJ-76CE	600	60	3	05945-111-69-12	05945-111-68-41	05945-111-81-33
AJ-76CS	208	60	1	N/A	N/A	N/A
AJ-76CS	230	60	1	N/A	N/A	N/A
AJ-76CS	208	60	3	05945-111-68-39	05945-111-68-41	05945-111-68-40
AJ-76CS	230	60	3	05945-111-68-39	05945-111-68-41	05945-111-68-40
AJ-76CS	460	60	3	05945-111-68-39	05945-111-68-41	05945-111-68-40
AJ-76CS	575	60	3	05945-111-69-12	05945-111-68-41	05945-111-68-41
AJ-76CS	600	60	3	05945-111-69-12	05945-111-68-41	05945-111-68-41
AJ-90CE	208	60	1	N/A	N/A	N/A
AJ-90CE	230	60	1	N/A	N/A	N/A
AJ-90CE	208	60	3	05945-111-68-39	05945-111-68-41	05945-111-68-40
AJ-90CE	230	60	3	05945-111-68-39	05945-111-68-41	05945-111-68-40
AJ-90CE	460	60	3	05945-111-68-39	05945-111-68-41	05945-111-68-40
AJ-90CE	575	60	3	05945-111-69-12	05945-111-68-41	05945-111-68-41
AJ-90CE	600	60	3	05945-111-69-12	05945-111-68-41	05945-111-81-33
AJ-90CS	208	60	1	N/A	N/A	N/A
AJ-90CS	230	60	1	N/A	N/A	N/A
AJ-90CS	208	60	3	05945-111-68-39	05945-111-68-40	05945-111-68-40
AJ-90CS	230	60	3	05945-111-68-39	05945-111-68-40	05945-111-68-40
AJ-90CS	460	60	3	05945-111-68-39	05945-111-68-40	05945-111-68-40
AJ-90CS	575	60	3	05945-111-69-12	05945-111-68-41	05945-111-68-41
AJ-90CS	600	60	3	05945-111-69-12	05945-111-68-41	05945-111-81-33

SECTION 6: PARTS SECTION

HEATER ASSEMBLY

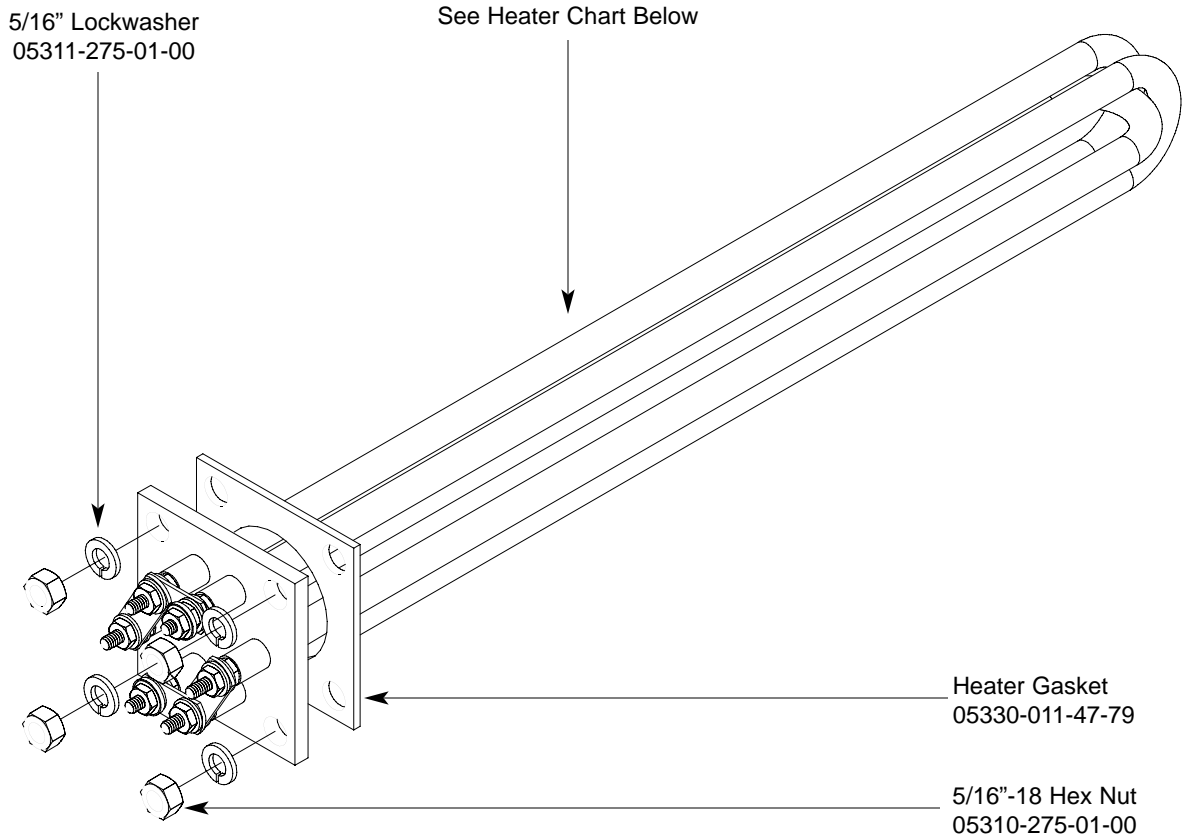

Heater Chart

<u>Model</u>	<u>Volts</u>	<u>Phase</u>	<u>KW</u>	<u>Part Number</u>
All*	208	1	10	06401-003-12-94
	230	1	10	06401-003-12-95
	208	3	10	06401-003-12-94
	230	3	10	06401-003-12-95
	460	3	10	06401-003-12-96
	575	3	10	06401-003-12-97
	575	3	18	04540-003-06-22
	600	3	10	06401-003-12-97

* - AJ-54CGP, AJ-54CS, AJ-76CGP, AJ-76CS and AJ-90CS models do not use electric heaters in the wash tank or power rinse tank.

SERVICE NOTE: When replacing the tub heaters, it is HIGHLY recommended that you also change out the gasket as well. Once installed, gaskets become compressed and are subjected to extreme temperature changes. Replacing the gasket with a new one when replacing the heater may prevent future leaks.

SERVICE NOTE: The nuts used to secure the heater to the tub should be torqued to 16 in-lbs. After tightening, the unit should be allowed to heat up and operate normally for approximately 30 minutes. Secure power to the machine and check the nuts once more to ensure that they are torqued to 16 in-lbs.

SECTION 6: PARTS SECTION

HEATER ASSEMBLY (CONTINUED)

The wash tank heater system is electrically connected in the circuit so that they are dependent upon the dishwasher being properly filled with and maintaining a safe water level, two thermostats (mounted in the heater box behind the dress panel), float switch (mounted in the wash tank), and the heater relay (mounted in control box) with the heater being activated by the thermostats.

Once the dishwasher has been filled to the correct level, the heater should operate automatically. Should the tank heat be too high, too low or no indication of temperatures at all, the following checkout should be made.

Note: The following checkout should be made by either a qualified service person or electrician.

A- Checkout of the heater system

- 1- If the temperature is too high, adjust thermostat using instructions on the page entitled "Thermostats".
- 2- If temperature is too low, adjust thermostat as above, then:
 - a - Turn off power to machine by placing customer's circuit breaker in the "OFF" position. Turn off machine circuit breaker located on right side of control box.
 - b - Remove cover from control box on top of dishwasher.
 - c - Make sure water temperature is below 140° F.(preferably about 130°F.).
 - d - Turn on both circuit breakers. Observe heater relay (R1) while the power switch is turned "ON" and "OFF". If relay contacts move in and out, the heater relay is operating correctly: if not proceed to "C".

B- If heater relay (R1) closes:

- 1 - Check power supply at incoming terminal board L1, L2 & L3. It should be the same voltage as indicated on the machine data plate.
- 2 - Check power at connections on heater relay (R1). The voltage should agree with the voltage on the machine data plate. If not, check wires for breaks or bad connections.
- 3 - Check power at terminals of heater which should agree with the data plate. If not check wires for breaks or bad connections.
- 4 - Temperatures should rise as explained in "C-1", and amperage may be checked according to those instructions. Replace any defective elements.

C - If heater relay (R1) does not close.

- 1 - There is an insulated movable insulated movable bar on relay across the top. With an insulated probe, depress this bar and observe the thermometer: the temperature should rise noticeably in a minute or two. If it moves slowly, it would indicate that the element is faulty. If it moves constantly higher at a good rate, elements should be good.

Note: A check with an amp probe at heater relay (R1) terminals should be made to verify the amp draw on each leg. This should be appropriate for the voltage and phase indicated on the data plate

HEATER PROTECTION & AUTOMATIC FILL

This control is activated when the power switch is turned "ON". The primary function is to automatically energize the wash tank heat circuit. It will also cutoff the wash tank heat circuit should the water be accidently drained from the machine with the power switch still "ON". The power switch should always be turned-off before draining the unit.

This water level control consists of two (2) floats that operate when the power switch is turned on and works in conjunction with the thermostats and heater relays.

When the power switch is turned "ON" water starts to enter the dishmachine. When it reaches the proper level the normally open contacts in the water level float switch close activating the heating circuit for tank heat.

If the water level below the correct level while power is still on, the float switch will sense the lack of water and de-activate the heater.

SECTION 6: PARTS SECTION
THERMOSTATS/FRAME ASSEMBLY/DRESS PANELS

THERMOSTATS

The thermostat range is from 140°F to 240°F with a maximum bulb exposure temperature of 300°F.

Calibration:

Wash Thermostat:

Set Point: 165°F (Adjustable range)

Hi-Limit Thermostat:

Fixed set point: 210°F (Non-adjustable)

The hi-limit thermostat is used to protect the heater element in the event of a run away regulating thermostat or a dry fire situation. It is set for 210°F +0°F or -10°F with a fixed set point. **This part is not adjustable.**

The wash tank regulating thermostat will maintain the correct wash water temperature to meet NSF requirements. These specify that the wash be no lower than 160°F on hot water sanitizing machines.

To order the thermostats and corresponding decals:

Kit, Thermostat, Wash Regulating (CE Models)	06401-003-18-20
Kit, Thermostat, Wash Regulating (CS Models)	06401-003-18-21
Thermostat, High Limit Control	05930-011-49-43
1/4" Imperial Brass Fitting	05310-924-02-05

HEATER BOX COMPONENTS

Heater Box Weldment	05700-031-66-81
Heater Box Cover	05700-031-66-82
Terminal Board	05940-002-78-97

FRAME WELDMENTS

<u>Model</u>	<u>Left to Right Part Number</u>	<u>Right to Left Part Number</u>
AJ-54's	05700-031-75-20	05700-031-75-20
AJ-54CGP	05700-002-65-68	05700-002-65-68
AJ-76's	05700-031-75-25	05700-031-75-22
AJ-76CGP	05700-031-75-25	N/A
AJ-90's	05700-031-75-26	05700-031-75-24

Bullet Feet (4 per model) - order using part number 5340-011-71-74.

FRONT DRESS PANELS

<u>Model</u>	<u>Left to Right Part Number</u>	<u>Right to Left Part Number</u>
AJ-54's	05700-031-72-22	05700-031-72-22
AJ-54CGP	05700-002-63-12	05700-002-63-12
AJ-76's	05700-031-71-85	05700-031-72-42
AJ-76CGP	05700-002-89-68	N/A
AJ-90's	05700-031-74-06	05700-031-77-10

SECTION 6: PARTS SECTION
PREWASH PLUMBING ASSEMBLY

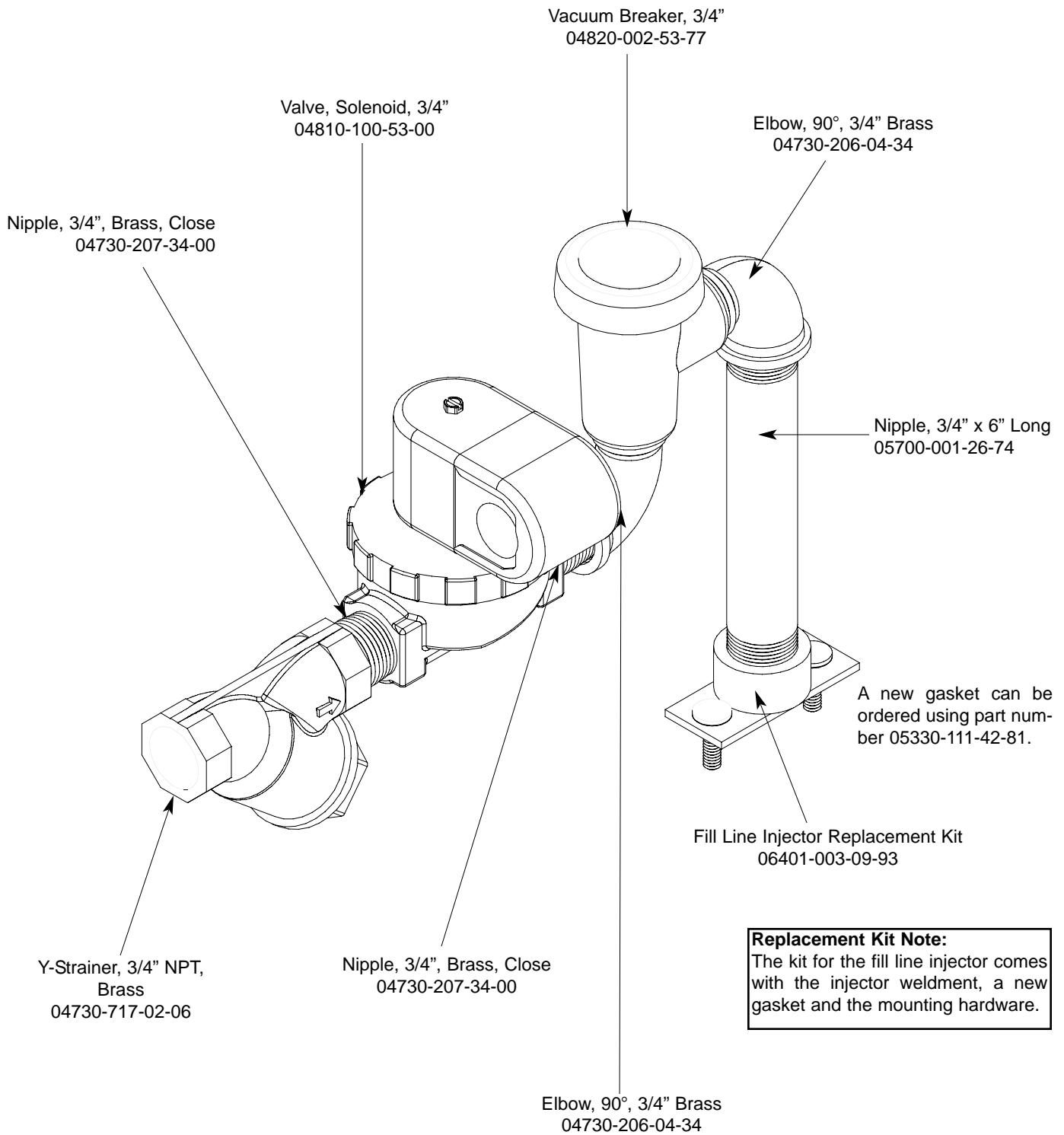

SECTION 6: PARTS SECTION
WASH SECTION INCOMING PLUMBING ASSEMBLY

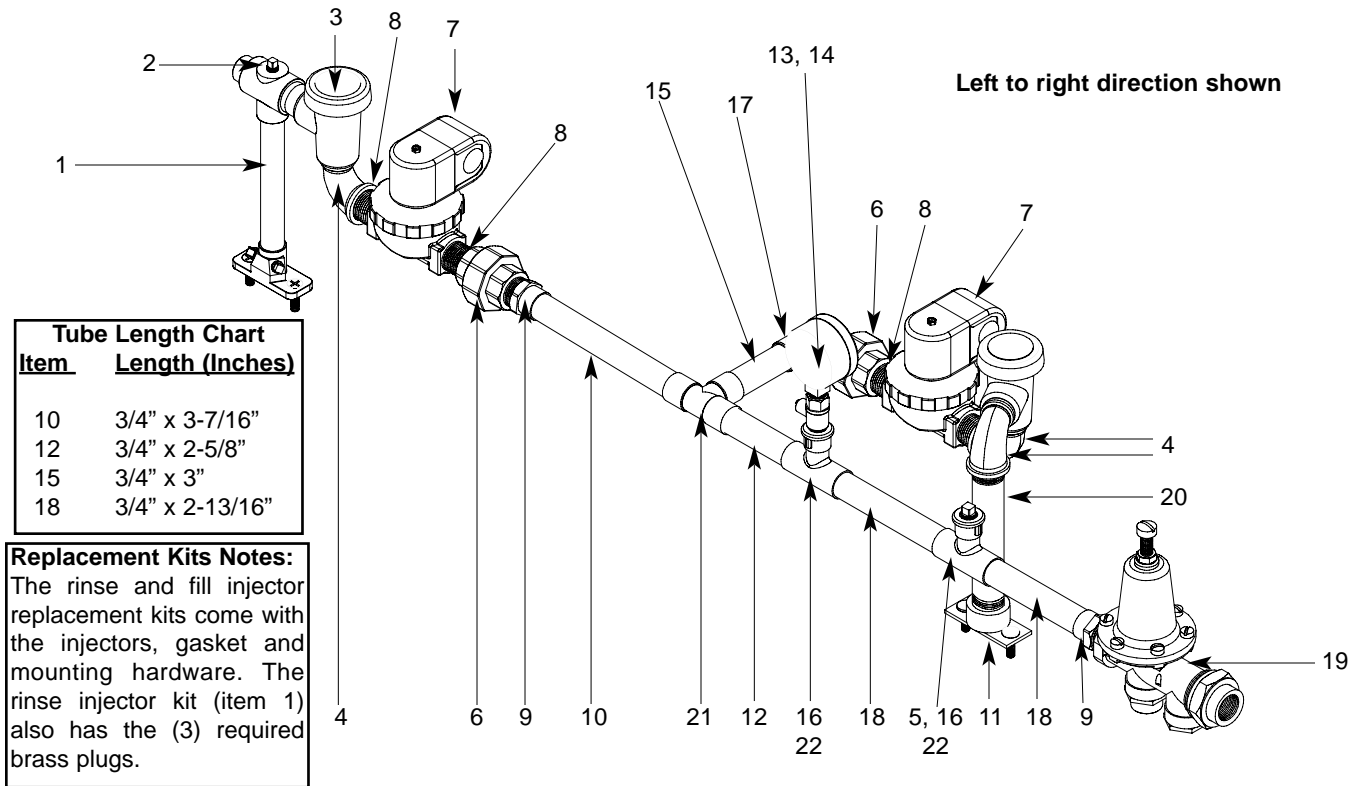

ITEM	QTY	DESCRIPTION	Mfg. No.
1	1	Rinse Injector Replacement Kit	06401-003-11-88
	1	Gasket	05330-111-42-81
2	3	Plug, Brass, 1/8" NPT	04730-209-07-37
3	2	Vacuum Breaker, 3/4" NPT	04820-002-53-77
4	3	Elbow, Street, 3/4" NPT	04730-206-04-34
5	1	Plug	04730-209-01-00
6	2	Union, Brass, 3/4"	04730-212-05-00
7	2	Solenoid Valve, 3/4"	04810-100-53-00
8	4	Nipple, Close, Brass, 3/4" NPT	04730-207-34-00
9	2	Fitting, 3/4" Male to Slip Copper	04730-401-11-01
10	1	Tube, Copper	See Chart
11	1	Fill Injector Replacement Kit	06401-003-09-93
	1	Gasket	05330-111-42-81
12	1	Tube, Copper	See Chart
13	1	Gauge, Pressure, 0-100 PSI	06685-111-88-34
	1	Decal, 15-25 PSI	09905-002-97-74
14	1	Valve, Ball, Test Cock, 1/4" NPT	04810-011-72-67
15	1	Tube, Copper	See Chart
16	2	Tee, 3/4" x 3/4" x 1/2"	04730-411-03-01
17	1	Elbow, Brass, 90°, 3/4" Copper	04730-406-42-01
18	2	Tube, Copper	See Chart
19	1	Regulator, Pressure, 3/4" NPT, Brass	06685-011-58-22
20	1	Nipple, Brass, 6" Long	05700-001-26-74
21	1	Tee, 3/4", CUB x CUB x CUB	04730-
411-46-01			
22	2	Fitting, Adapter, 1/2" to 1/4"	04730-401-41-01

SECTION 6: PARTS SECTION

EXTERNAL ELECTRIC BOOSTER INCOMING PLUMBING ASSEMBLIES

Plumbing with Water Hammer Arrestor

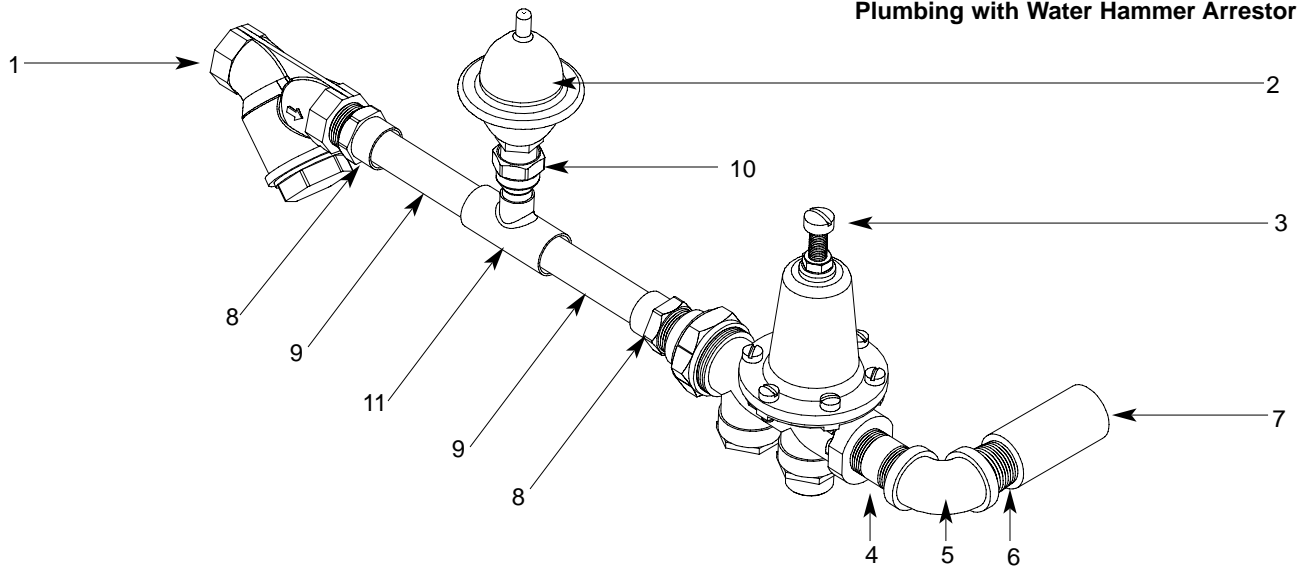

Plumbing without Water Hammer Arrestor

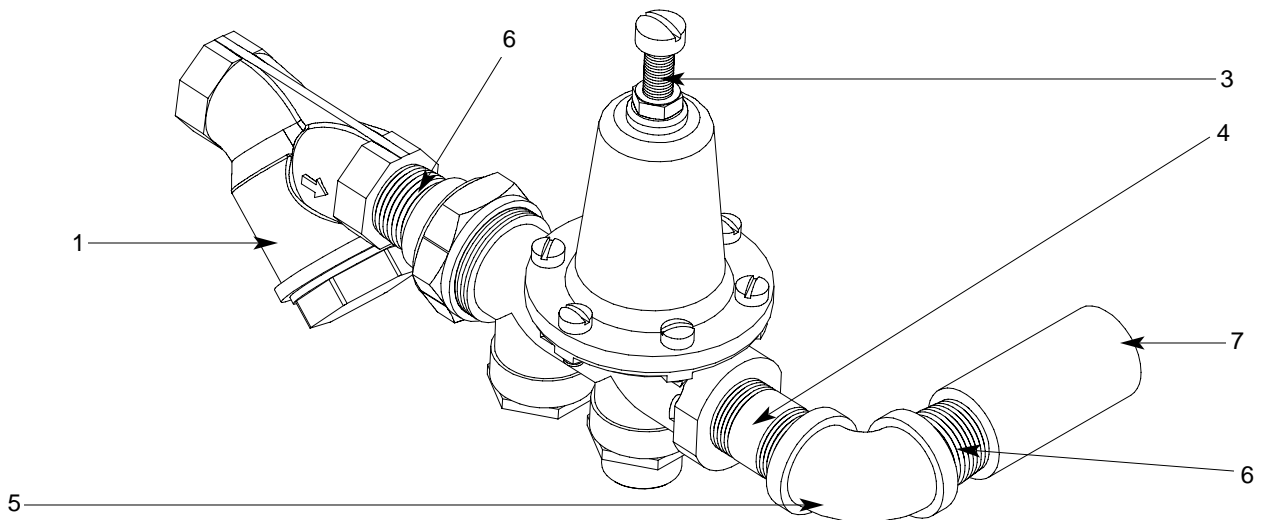

ITEM	QTY	DESCRIPTION	Mfg. No.
1	-	Y-Strainer, 3/4" NPT, Brass	04730-717-02-06
2	-	Arrestor, Water Hammer, 1/2" NPT	06685-100-05-00
3	-	Regulator, Pressure, 3/4" NPT, Brass	06685-011-58-22
4	-	Nipple, 3/4" NPT x 2" Long, Brass	04730-207-46-00
5	-	Elbow, Brass, 90°, 3/4"	04730-206-13-00
6	-	Nipple, 3/4" NPT, Close, Brass	04730-207-34-00
7	-	Coupling, 3/4" FNPT x 3/4" FNPT, Brass	04730-011-87-95
8	-	Adapter, 3/4" Male	04730-401-11-01
9	-	Tube, Copper, 3/4" x 3-7/16" Long	05700-011-72-70
10	-	Adapter, 1/2" NPT x Male	04730-401-07-01
11	-	Tee, Copper, 3/4" x 3/4" x 1/2"	04730-411-03-01

SECTION 6: PARTS SECTION
EXTERNAL ELECTRIC BOOSTER OPTION OUTLET PLUMBING

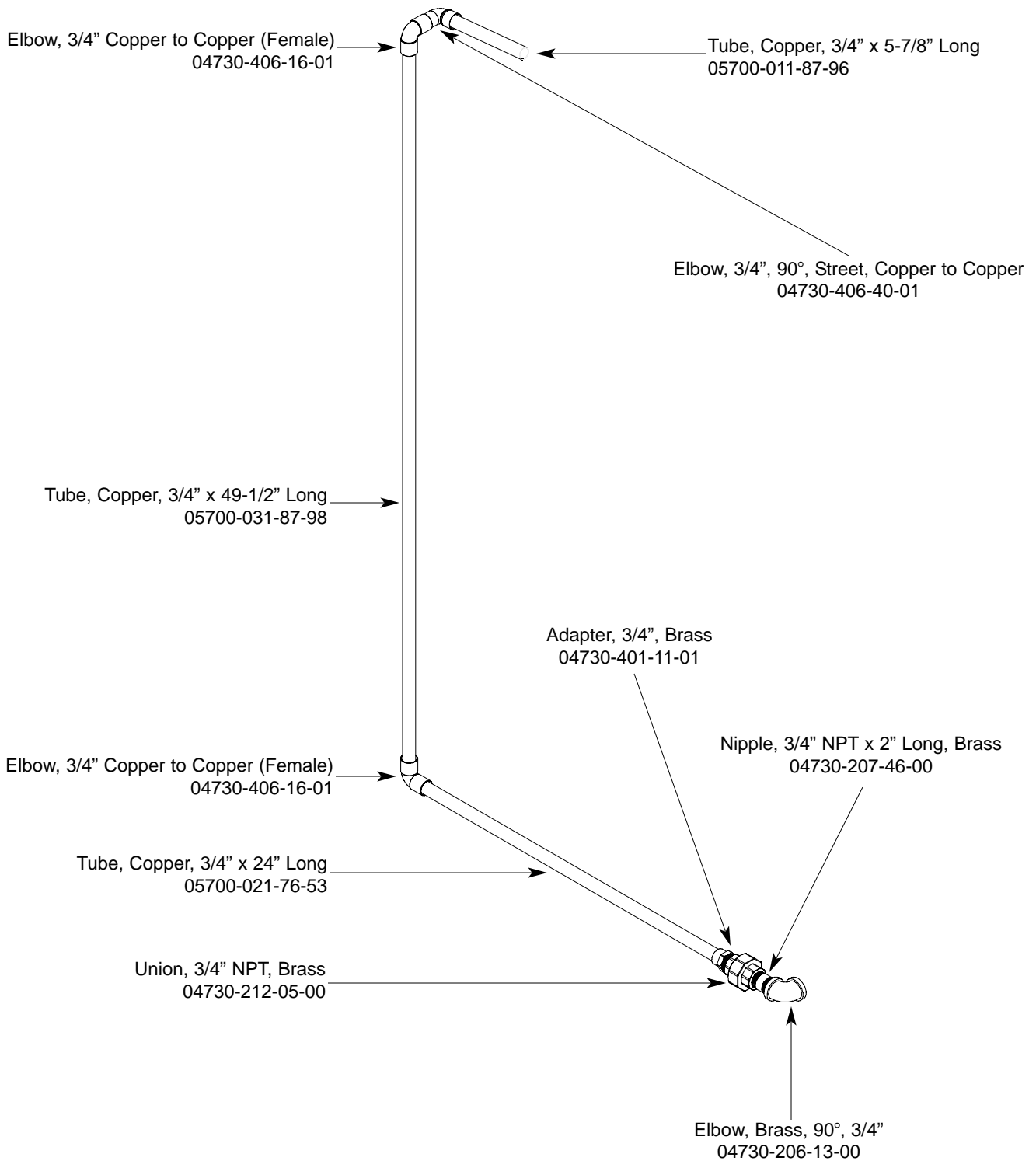

SECTION 6: PARTS SECTION

WATER HAMMER ARRESTOR OPTION/WATER PRESSURE REGULATOR KIT OPTION

WATER HAMMER ARRESTOR OPTION

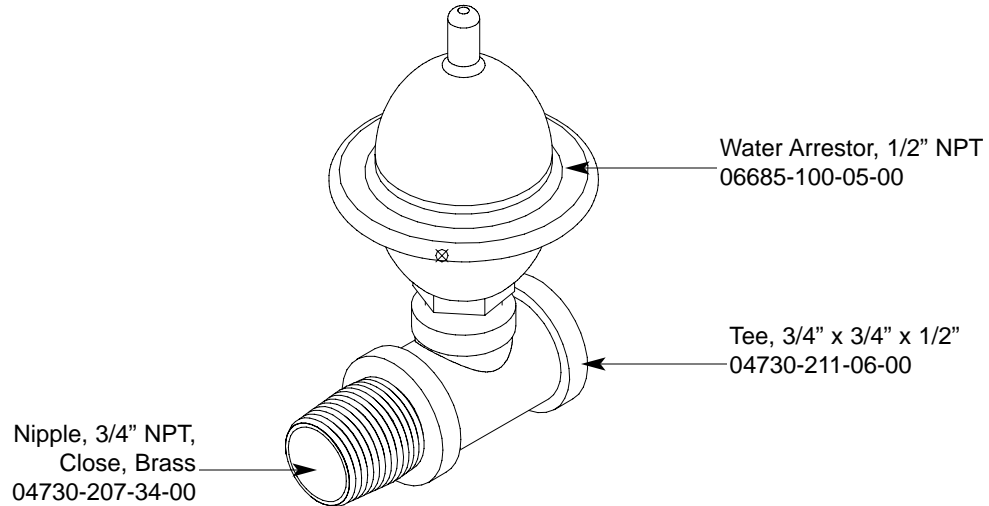

WATER PRESSURE REGULATOR WITH ARRESTOR KIT OPTION

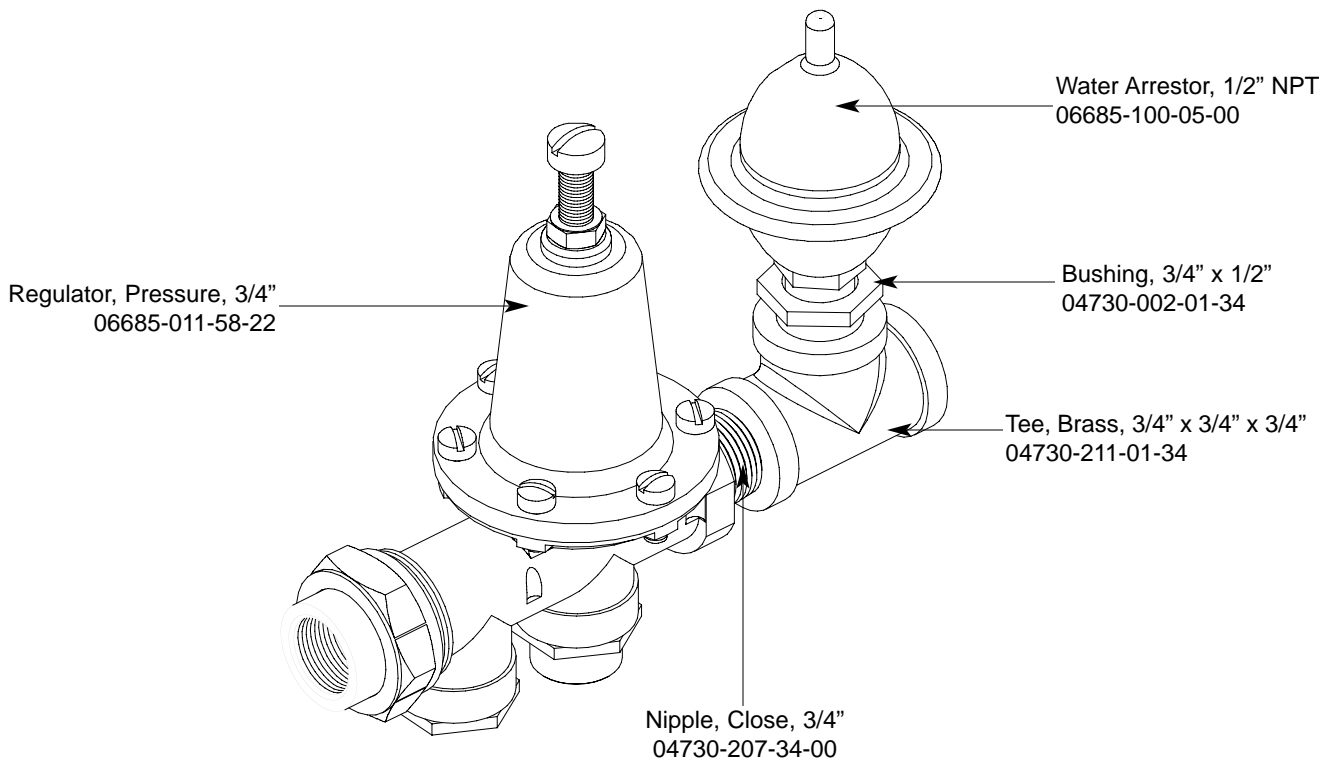

SECTION 6: PARTS SECTION

RINSE SOLENOID VALVE & VACUUM BREAKER REPAIR PARTS KITS

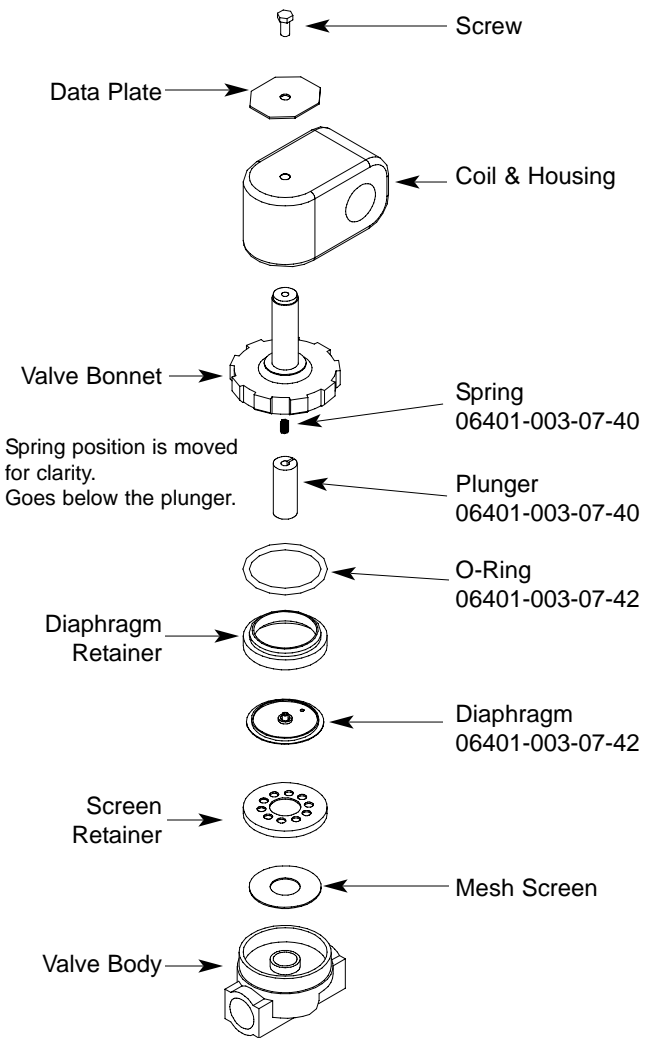

Complete 110 Volt Solenoid Valve Assembly, 3/4"
04810-100-53-00

Coil & Housing only, 3/4"
06401-003-07-43

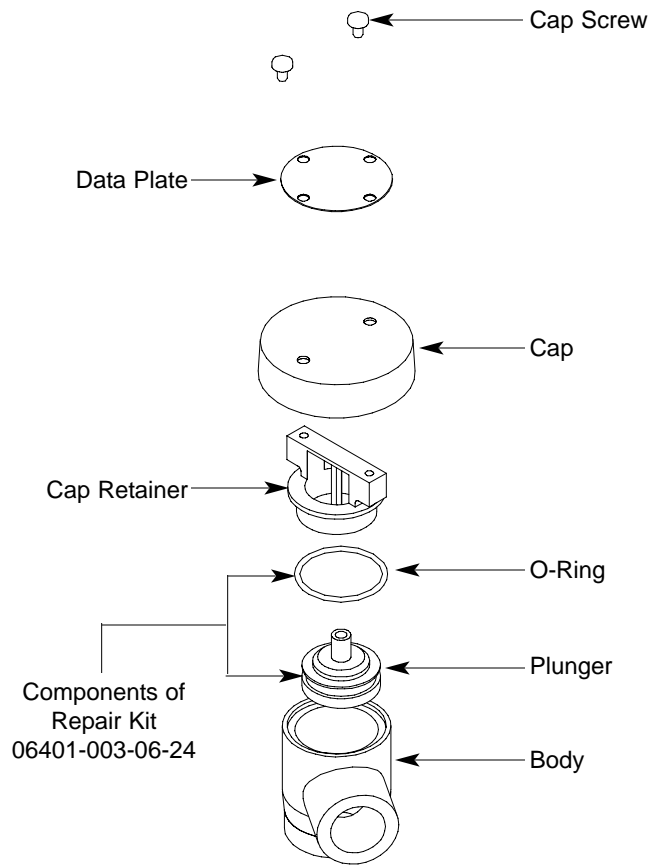

Complete Vacuum Breaker Assembly, 3/4" NPT
04820-002-53-77

SECTION 6: PARTS SECTION
STEAM UNIT WASH TANK COIL ASSEMBLY

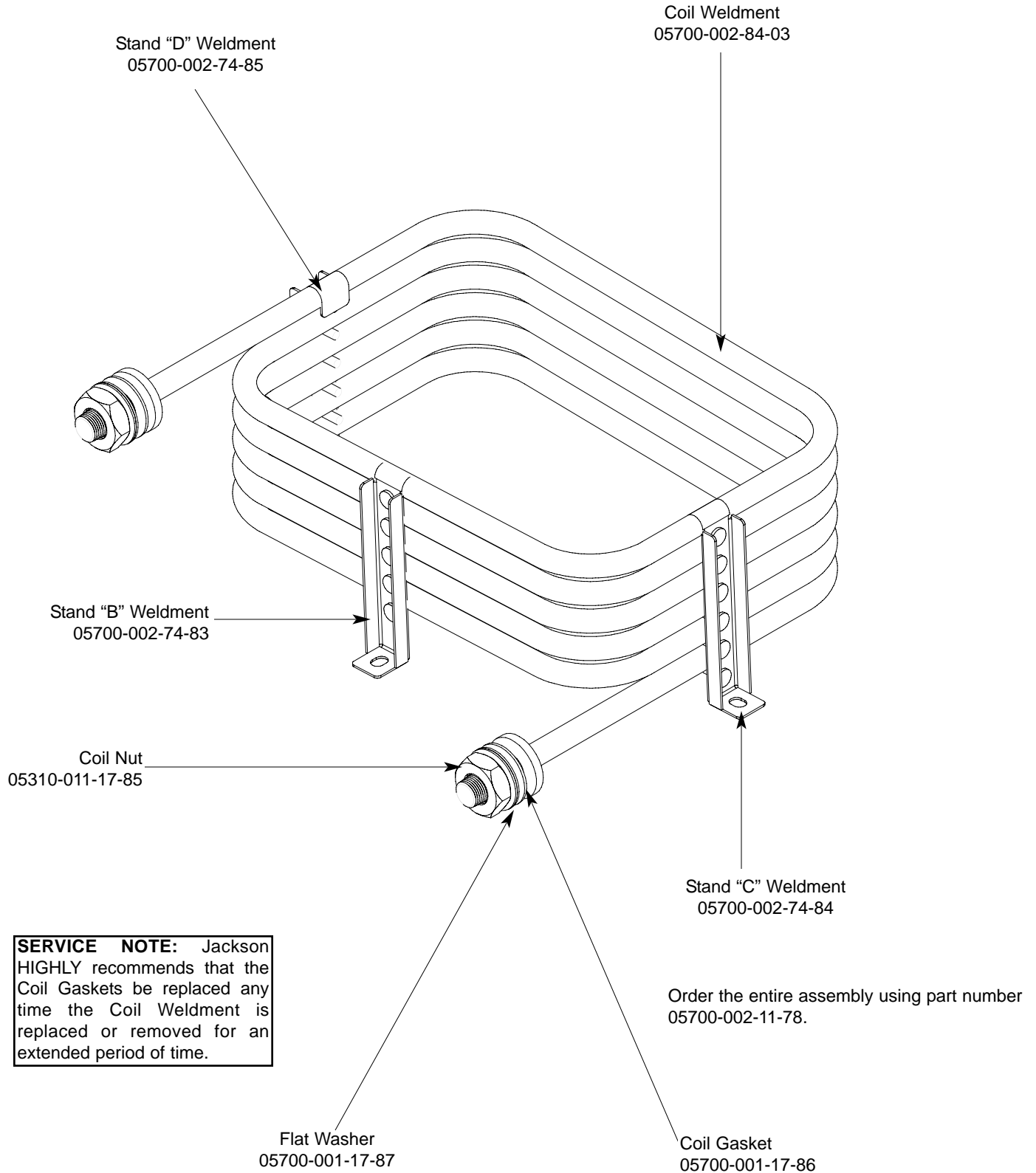

SECTION 6: PARTS SECTION
STEAM PLUMBING (LEFT TO RIGHT)

STEAM INLET PLUMBING

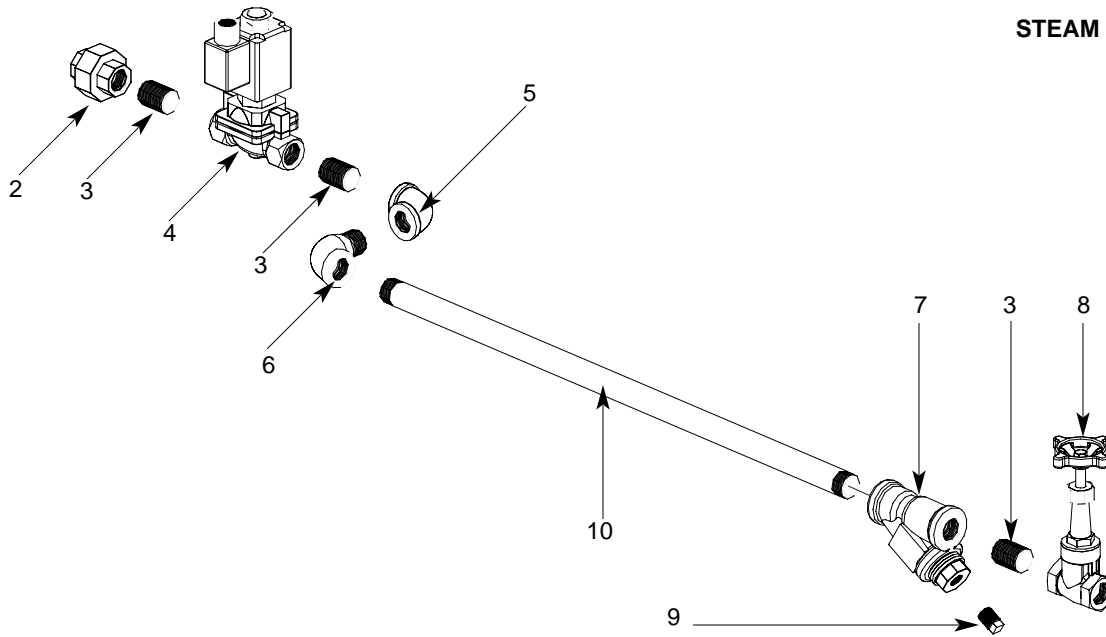

ITEM	QTY	DESCRIPTION	Mfg. No.
1	1	Reducer, 3/4" NPT to 1/2" NPT, Black Iron	04730-911-02-34
2	2	Union, 3/4" NPT, Black Iron	04730-912-01-00
3	4	Nipple, Close, 3/4" NPT, Black Iron	04730-907-01-00
4	1	Valve, Steam Solenoid, 3/4" NPT, 120V	04820-011-87-39
5	2	Elbow, 90°, 3/4" FNPT, Black Iron	04730-906-10-34
6	2	Elbow, Street, 90°, 3/4" NPT, Black Iron	04730-011-87-37
7	1	Y-Strainer, 3/4" NPT, Black Iron	04730-217-01-32
8	1	Valve, Gate, Steam, 3/4" NPT	04820-100-19-00
9	1	Plug, 3/8" NPT, Black Iron	04730-909-02-34
10	1	Nipple, 3/4" NPT x 47" Long	04730-021-89-26
11	1	Pipe, 3/4" NPT x 2" Long, Black Iron	04730-907-05-34
12	1	Steam Trap, 3/4" NPT	06680-500-02-77

STEAM OUTLET PLUMBING

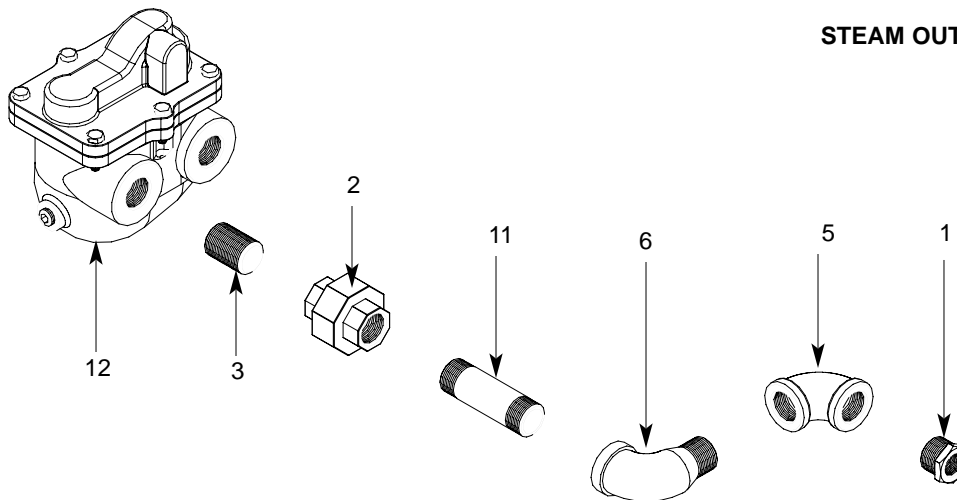

SECTION 6: PARTS SECTION
STEAM PLUMBING (RIGHT TO LEFT)

STEAM INLET PLUMBING

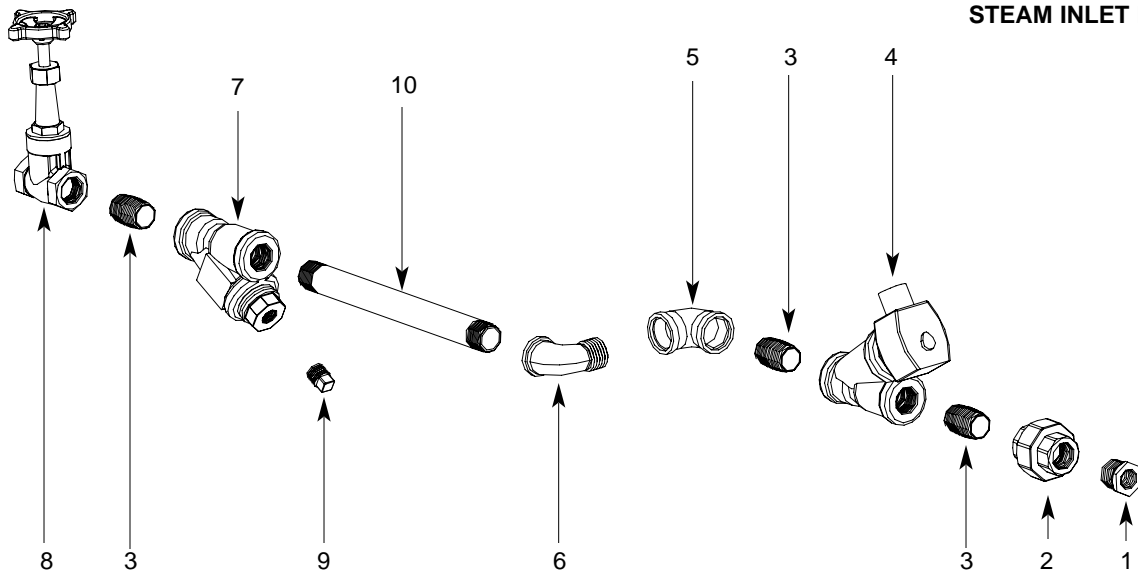

ITEM	QTY	DESCRIPTION	Mfg. No.
1	2	Reducer, 3/4" NPT to 1/2" NPT, Black Iron	04730-911-02-34
2	2	Union, 3/4" NPT, Black Iron	04730-912-01-00
3	4	Nipple, Close, 3/4" NPT, Black Iron	04730-907-01-00
4	1	Valve, Steam Solenoid, 3/4" NPT, 120V	04820-011-87-39
5	1	Elbow, 90°, 3/4" FNPT, Black Iron	04730-906-10-34
6	1	Elbow, Street, 90°, 3/4" NPT, Black Iron	04730-011-87-37
7	1	Y-Strainer, 3/4" NPT, Black Iron	04730-217-01-32
8	1	Valve, Gate, Steam, 3/4" NPT	04820-100-19-00
9	1	Plug, 3/8" NPT, Black Iron	04730-909-02-34
10	1	Nipple, 3/4" NPT x 10" Long	04730-907-06-34
11	1	Reducer, 3/4" NPT to 1/2" NPT, Black Iron	04730-911-02-34
12	1	Elbow, 90°, 3/4" FNPT, Black Iron	04730-906-10-34
13	1	Elbow, Street, 3/4" NPT, Black Iron	04730-011-87-37
14	1	Steam Trap, 3/4" NPT	06680-500-02-77

STEAM OUTLET PLUMBING

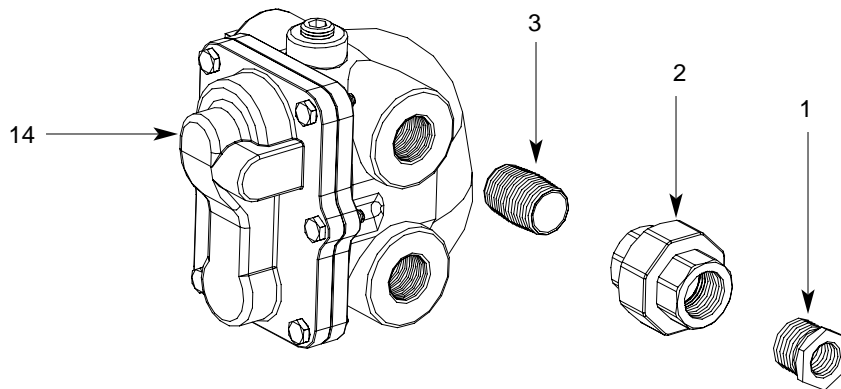

SECTION 6: PARTS SECTION
GAS COIL ASSEMBLY (CGP MODELS)

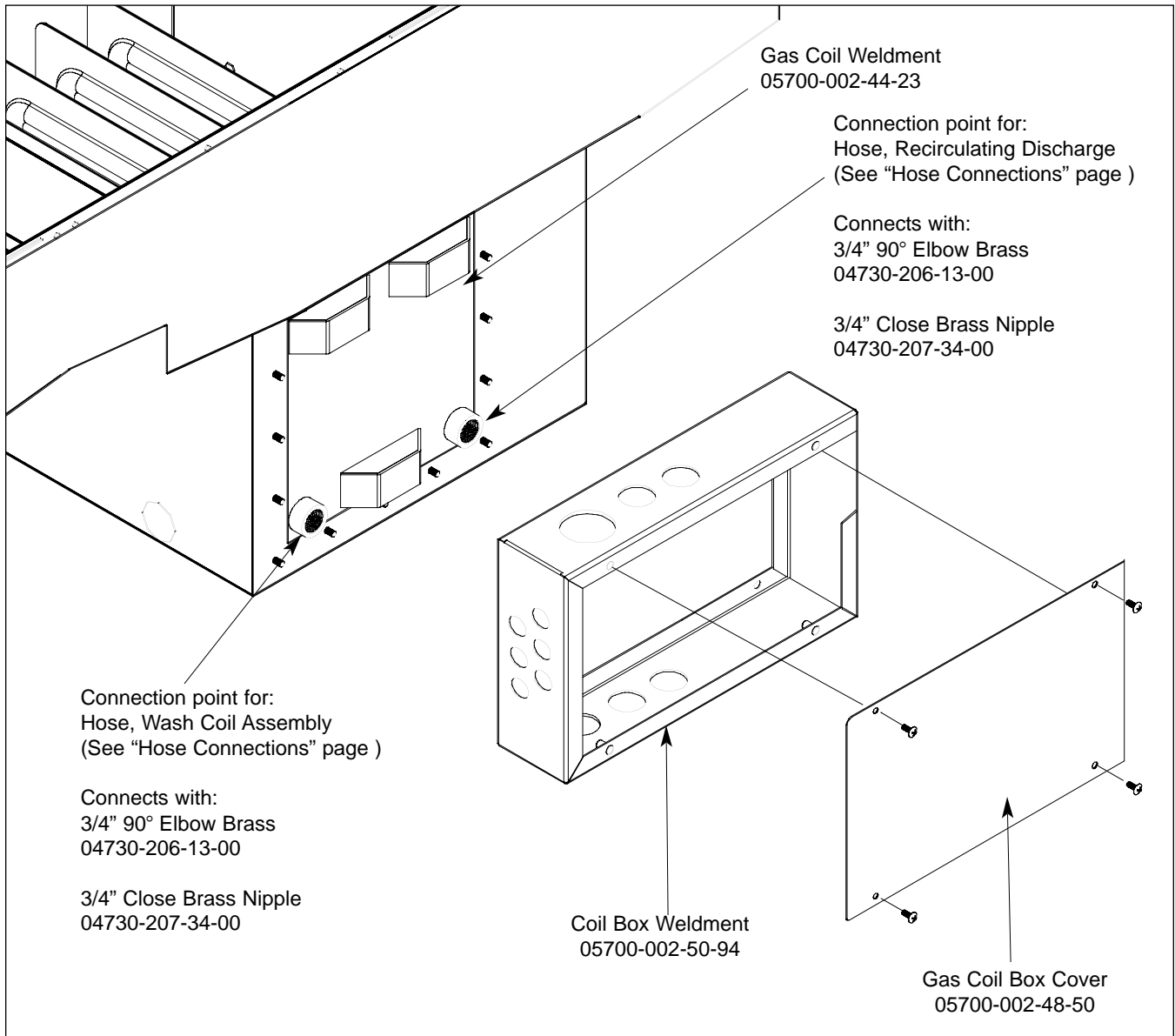

Other items used but not shown.

ITEM	QTY	DESCRIPTION	Mfg. No.
1	1	Thermostat, High Limit	05930-011-49-43
2	1	Gasket	05330-200-02-70
3	1	Terminal Board	05940-002-78-97
4	1	Thermostat Bracket	05700-011-81-64
5	1	Decal, Thermostat Regulating	09905-011-84-31
6	1	Thermostat, Wash Regulating	06401-140-00-32
7	2	Fitting, 1/4", Imperial Brass	05310-924-02-05

SECTION 6: PARTS SECTION
TANK, RINSE BOOSTER (CGP MODELS ONLY)

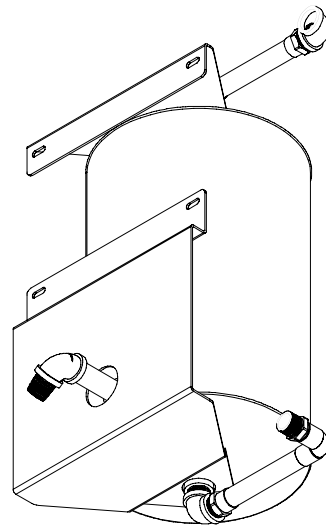
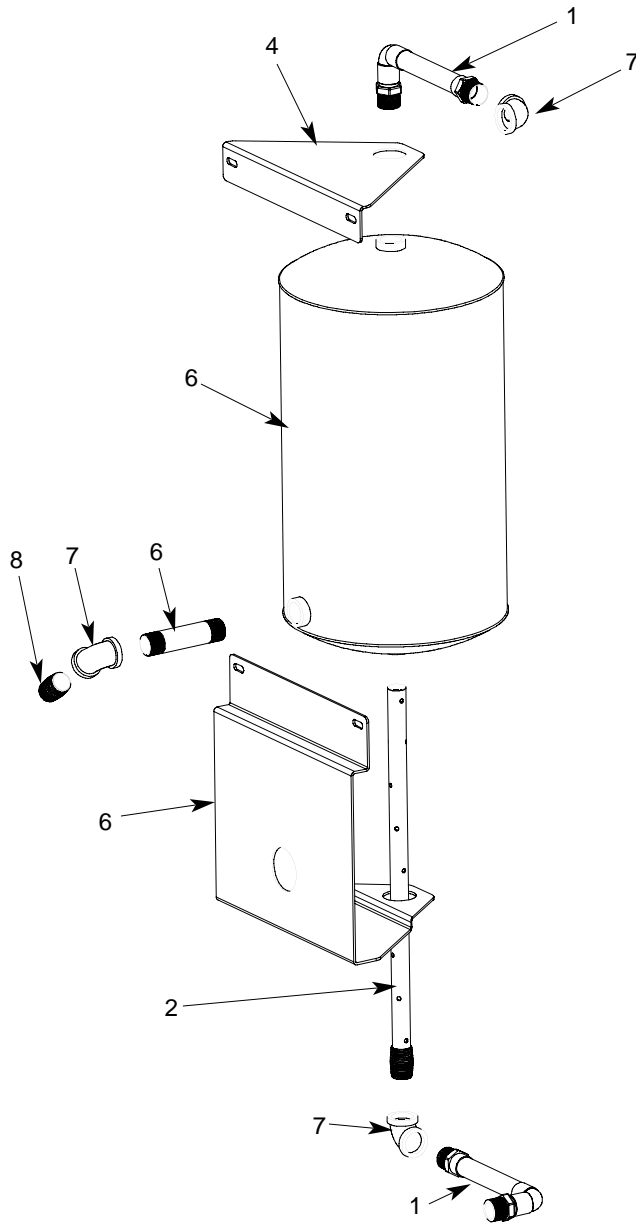

BOTTOM ANGLED VIEW

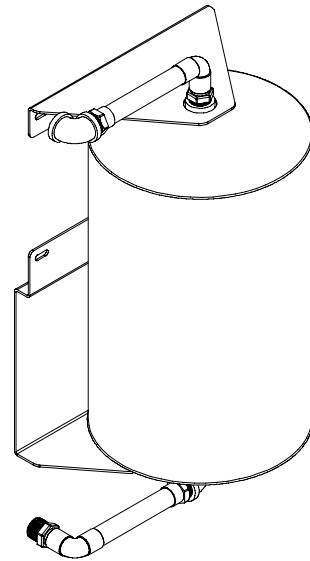

TOP ANGLED VIEW

ITEM	QTY	DESCRIPTION	Mfg. No.
1	2	Plumbing Assembly, Inlet/Discharge, Rinse Tank	05700-002-51-24
2	1	Tube, Dispersion Weldment	05700-002-46-16
3	1	Tank, GP Rinse	05700-002-45-05
4	1	Bracket, Upper Rinse Tank	05700-002-67-13
5	1	Bracket, Lower Rinse Tank	05700-002-67-14
6	1	Nipple, 3/4" NPT x 4" Long	04730-207-05-00
7	3	Elbow, 3/4" NPT, 90° Brass	04730-206-13-00
8	1	Nipple, 3/4" NPT x Closed Brass	04730-207-34-00

SECTION 6: PARTS SECTION
RECIRCULATING PUMP ASSEMBLY (CGP MODELS ONLY)

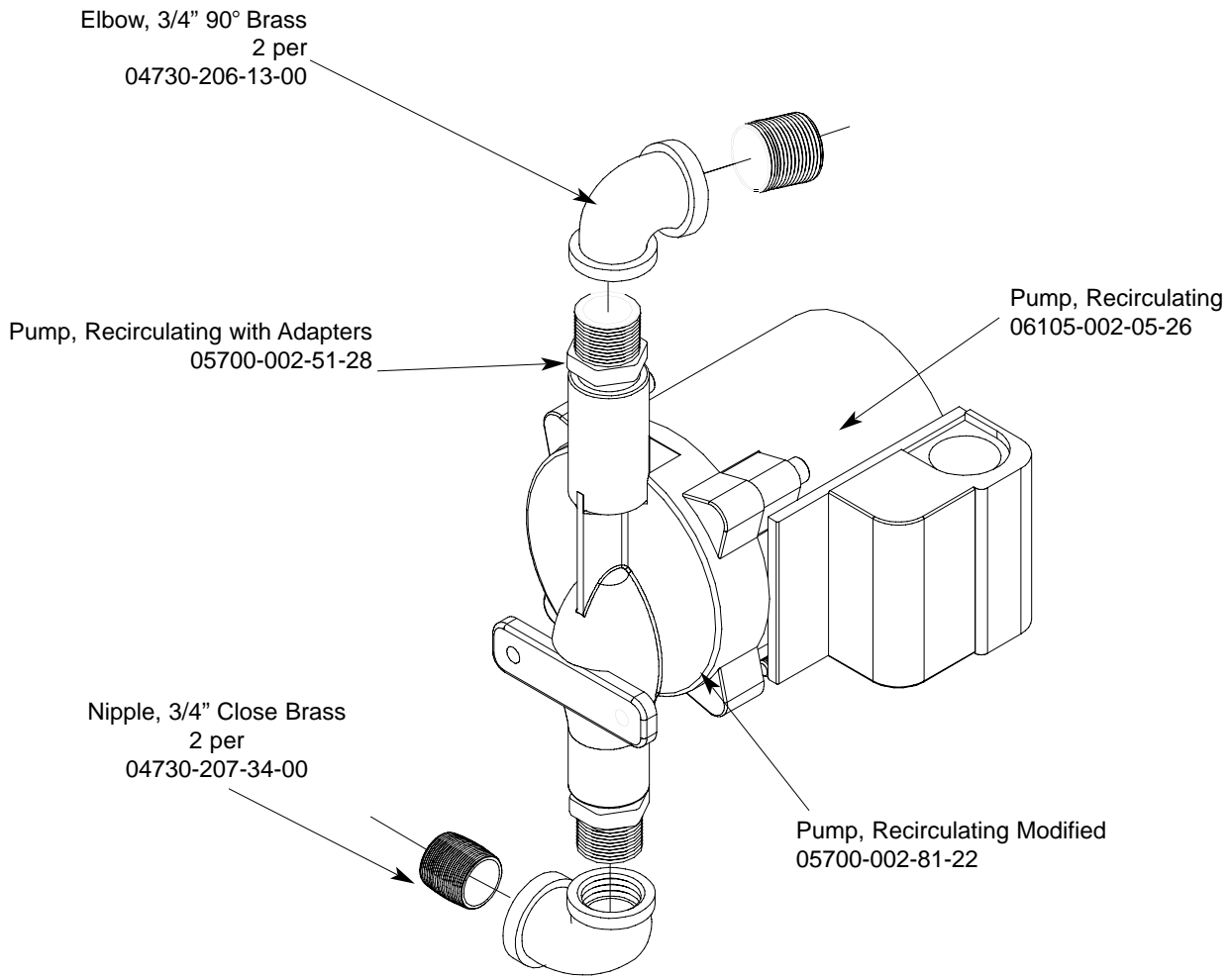

Used on AJ-54CGP, AJ-76CGP, AJ-90CGP units right to left units and the AJ-54CGP left to right unit.

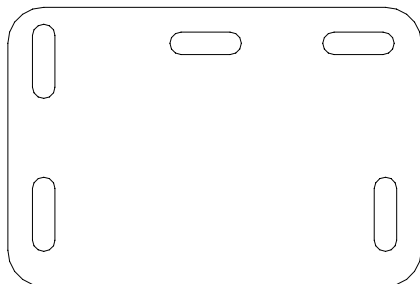

Mounting Bracket
05700-002-25-74

Used only on AJ-76CGP left to right units.

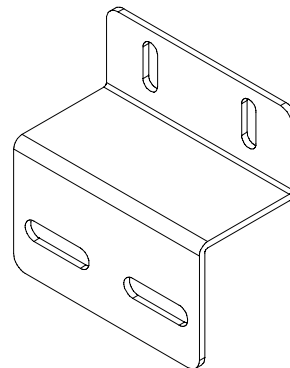

Mounting Bracket
05700-002-23-61

SECTION 6: PARTS SECTION
HOSE CONNECTIONS (CGP MODELS ONLY)

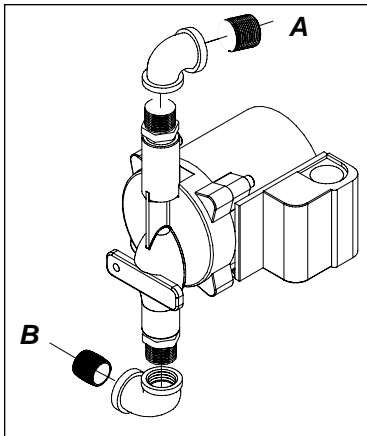

Recirculating Pump Assembly

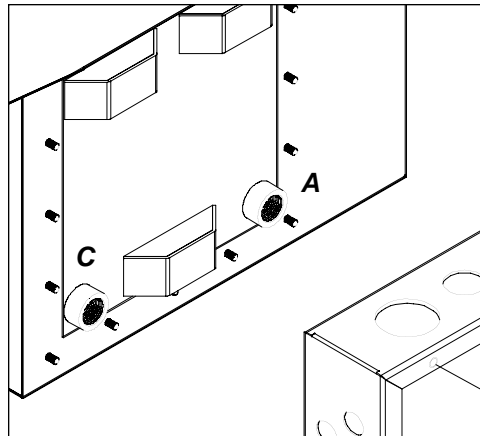

Gas Coil Weldment

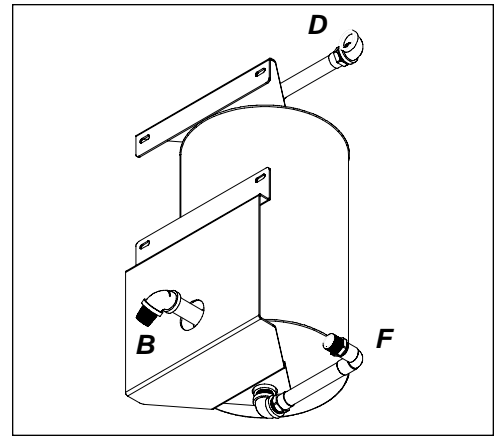

Rinse Booster Tank

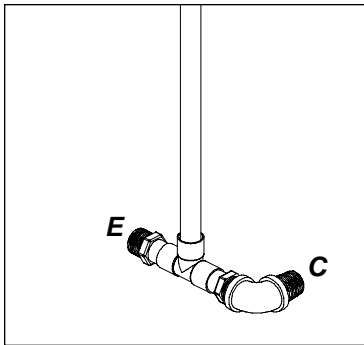

Rinse Header Plumbing Assembly

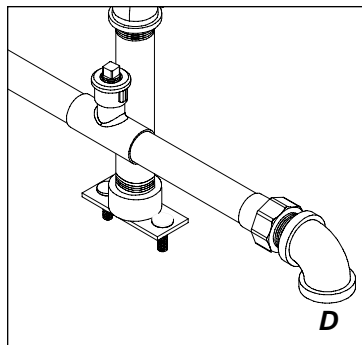

Wash/Fill Plumbing Assembly

HOSE ASSEMBLIES

AJ-54CGP (L-R & R-L)

AJ-76CGP (L-R)

*Each hose assembly includes 2, 3/4" Pushlock Fittings part number 04730-011-94-00.

A - Hose, Recirculating Discharge	(39") 05700-002-65-58	(31") 05700-002-89-69
B - Hose, Recirculating Pump Suction	(23 1/2") 05700-002-65-57	(18") 05700-002-51-38
C - Hose, Wash Coil Assembly	(34") 05700-002-52-76	(36") 05700-002-89-72
D - Hose, Wash/Fill Supply	(60") 05700-003-03-97	(60") 05700-003-03-97

E - Hose connection to existing gas booster outlet fitting.

F - Hose connection to existing gas booster inlet fitting.

Gas Booster Connection Kit 05700-002-51-73 includes:

18 Feet of 3/4" Hose

4 - 3/4" Push Lock Fittings

SECTION 6: PARTS SECTION
WASH/FILL PLUMBING ASSEMBLY (CGP MODELS)

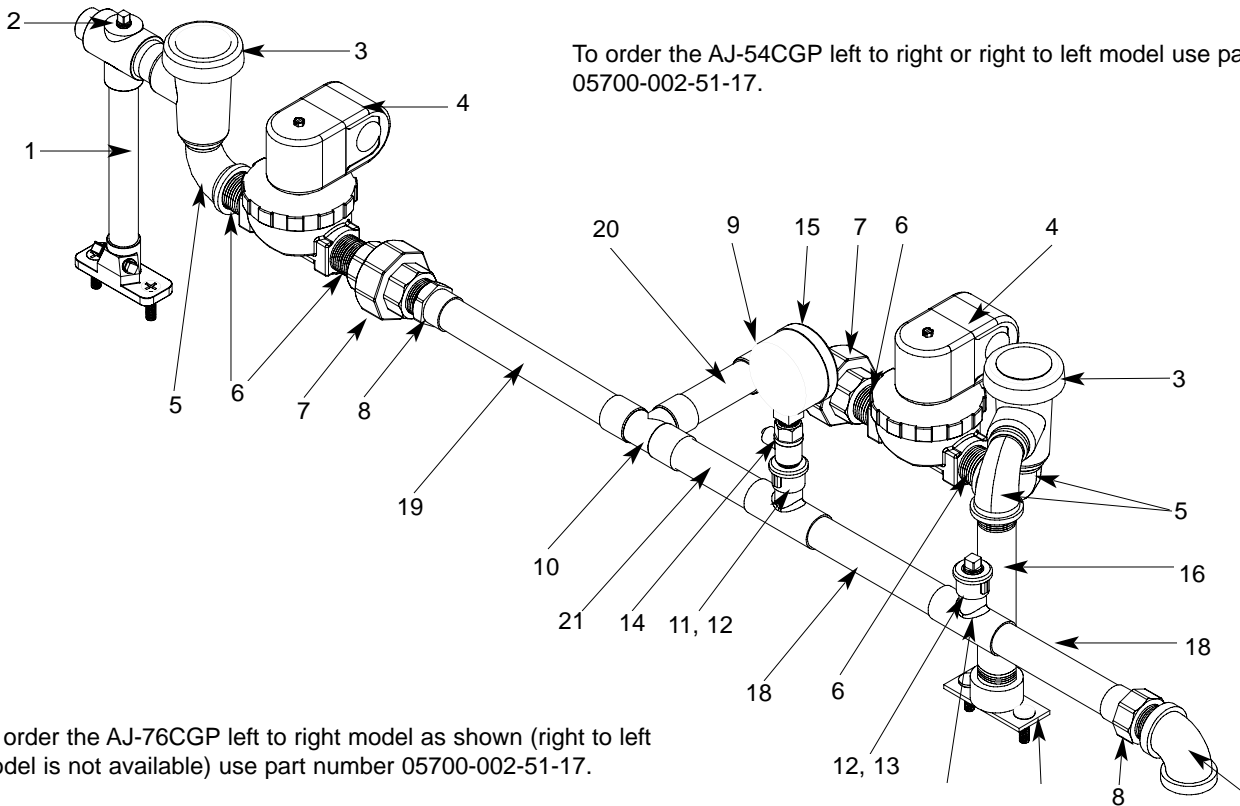

To order the AJ-54CGP left to right or right to left model use part number 05700-002-51-17.

To order the AJ-76CGP left to right model as shown (right to left model is not available) use part number 05700-002-51-17.

ITEM	QTY	DESCRIPTION	Mfg. No.
1	1	Rinse Injector Weldment	05700-002-57-87
	1	Gasket	05330-111-42-81
2	3	Plug, 1/8" NPT, Brass	04730-209-07-37
3	2	Vacuum Breaker, 3/4" NPT	04820-002-53-77
4	2	Valve, Solenoid, 3/4" NPT, 110 Volt	04810-100-53-00
5	3	Elbow, 3/4" Street Brass	04730-206-04-34
6	4	Nipple, Close, Brass, 3/4" NPT	04730-207-34-00
7	4	Union, 3/4", Copper to Copper	04730-212-05-00
8	2	Adapter, 3/4" Fitting x Male	04730-401-11-01
9	1	Elbow, 90° 3/4" Copper to MSPS	04730-406-42-01
10	1	Tee, 3/4", CUB x CUB x CUB	04730-411-46-01
11	2	Tee, 3/4" x 3/4" x 1/2"	04730-411-03-01
12	2	Fitting, Adapter, 1/2" to 1/4"	04730-401-41-01
13	1	Plug, 1/4" NPT, Brass	04730-209-01-00
14	1	Test Cock, Valve, Ball, 1/4" NPT	04810-011-72-67
15	1	Gauge, Pressure, 0-100 PSI	06685-111-88-34
	1	Decal, 15-25 PSI	09905-002-97-74
16	1	Nipple, Brass, 6" Long	05700-001-26-74
17	1	Fill Injector	05700-011-67-99
	1	Gasket	05330-111-42-81
18	1	Tube, Copper, 3/4" x 2 13/16" Long	05700-011-72-72
19	1	Tube, Copper, 3/4" x 3 7/16" Long	05700-011-72-70
20	1	Tube, Copper, 3/4" X 3" Long	05700-000-54-85
21	1	Tube, Copper, 3/4" x 2 5/8" Long	05700-011-72-71
22	1	Elbow, 3/4" NPT, 90° Brass	04730-206-13-00

SECTION 6: PARTS SECTION
RINSE HEADER PLUMBING ASSEMBLY (CGP MODELS)

Complete Plumbing Assembly
05700-002-51-16

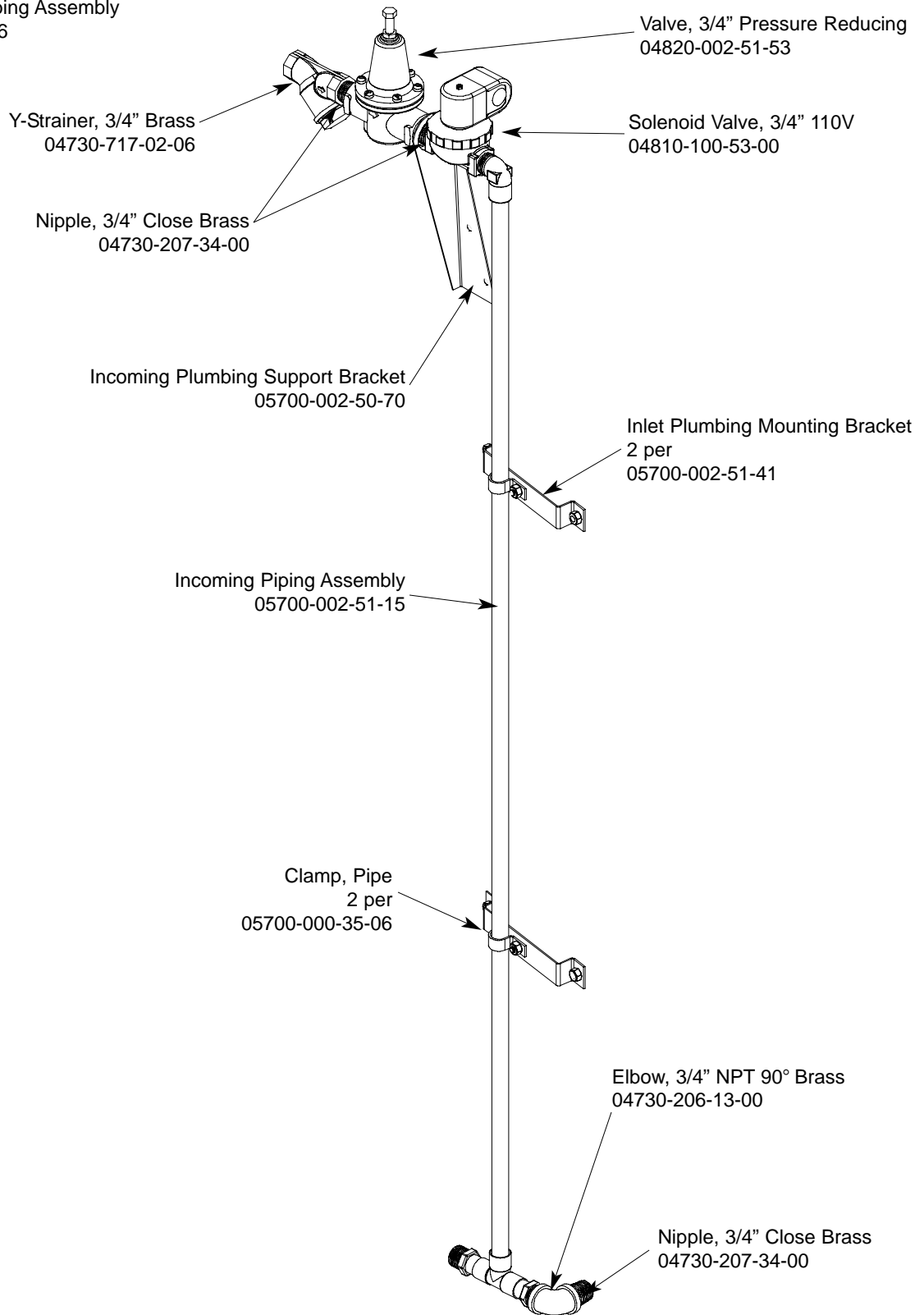

SECTION 6: PARTS SECTION
AJ-54 SERIES DRAIN PLUMBING ASSEMBLIES

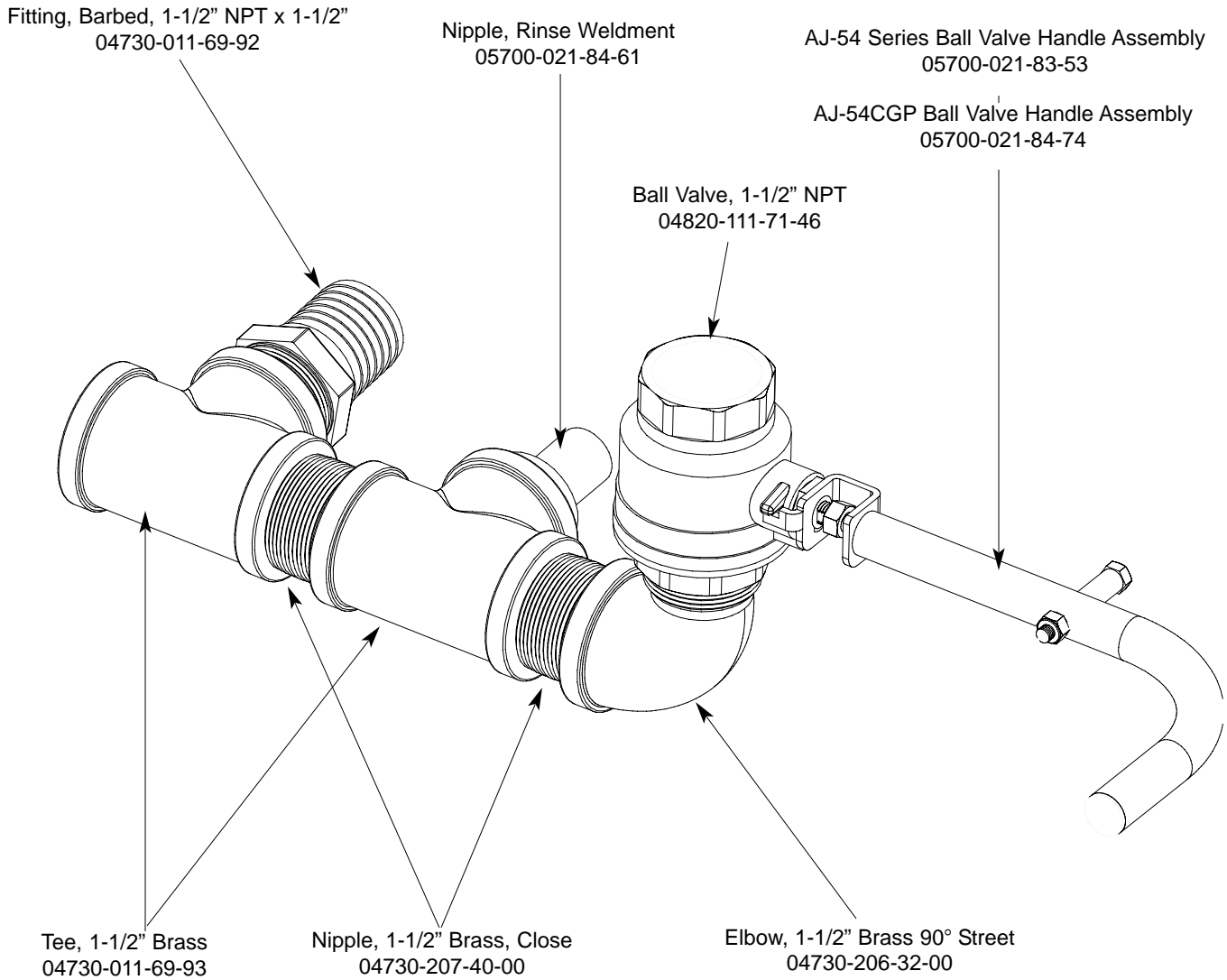

AJ-54 Series Complete Drain Assembly
05700-031-70-10

AJ-54CGP Complete Drain Assembly
05700-002-52-71

SECTION 6: PARTS SECTION

AJ-76 DRAIN PLUMBING ASSEMBLIES

Left to Right Plumbing Assembly

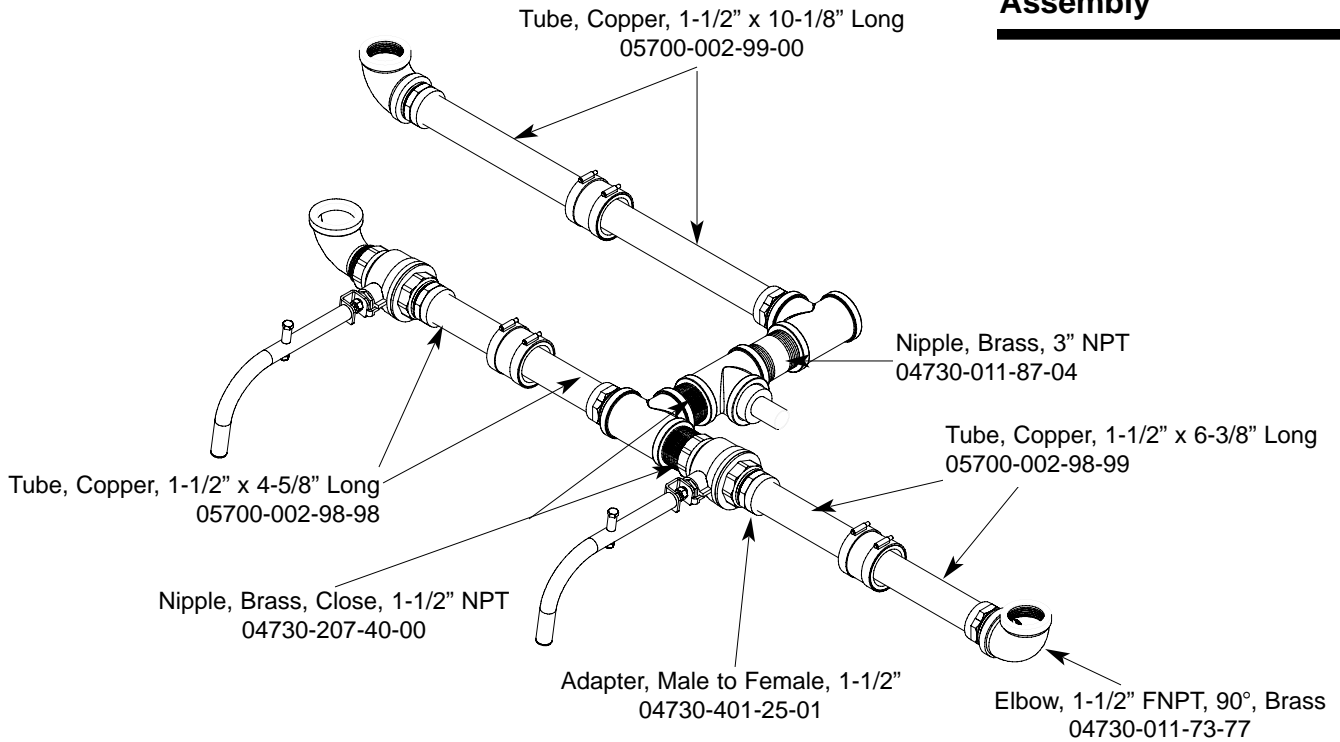

All parts are common to both assemblies.

Right to Left Plumbing Assembly

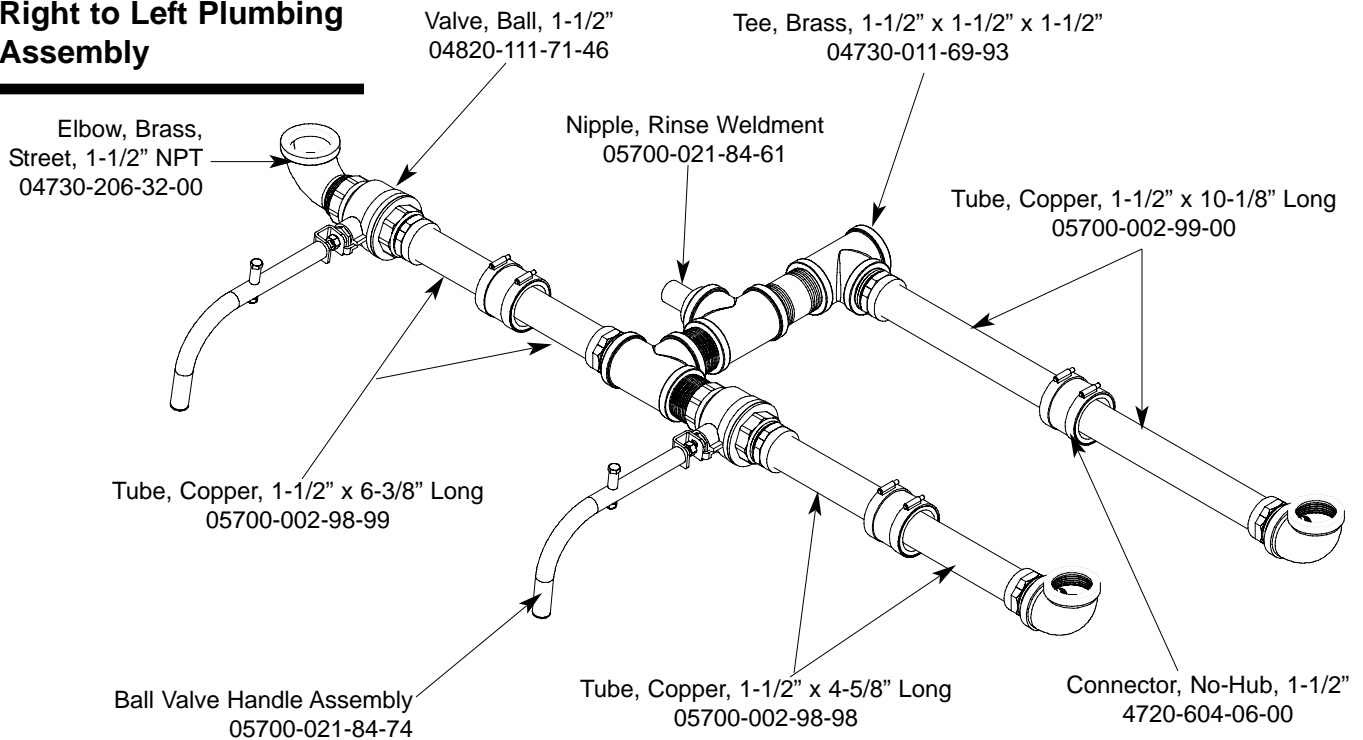

SECTION 6: PARTS SECTION

AJ-90 DRAIN PLUMBING ASSEMBLIES

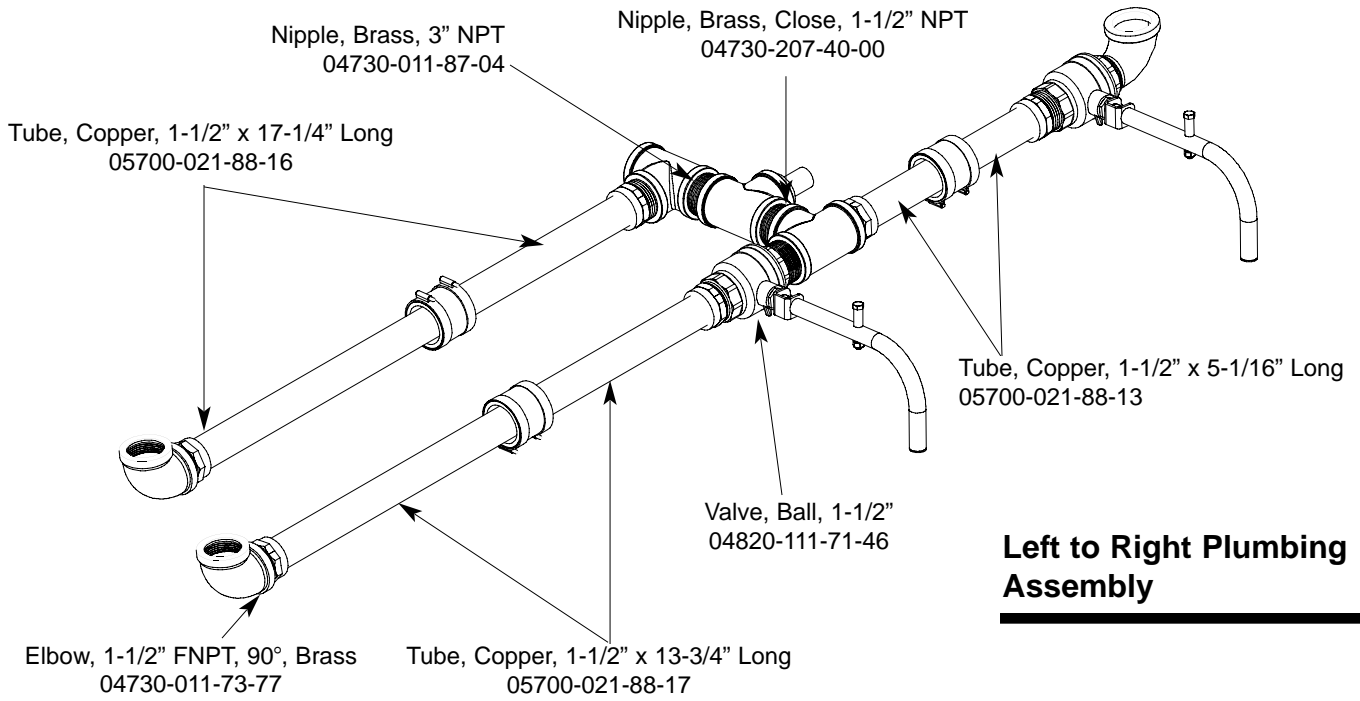

All parts are common to both assemblies.

Right to Left Plumbing Assembly

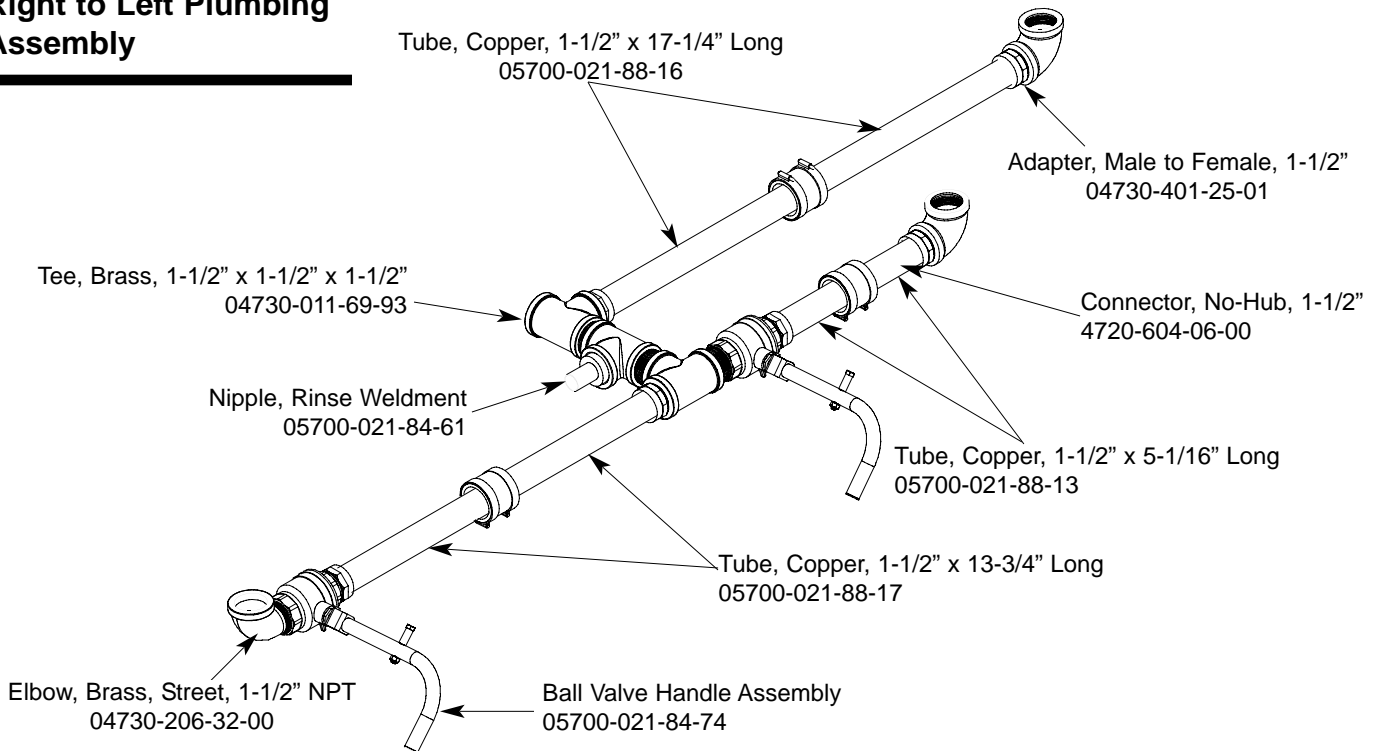

SECTION 6: PARTS SECTION

AJ-76CGP (LEFT TO RIGHT) DRAIN PLUMBING ASSEMBLY

(Right to left model not available.)

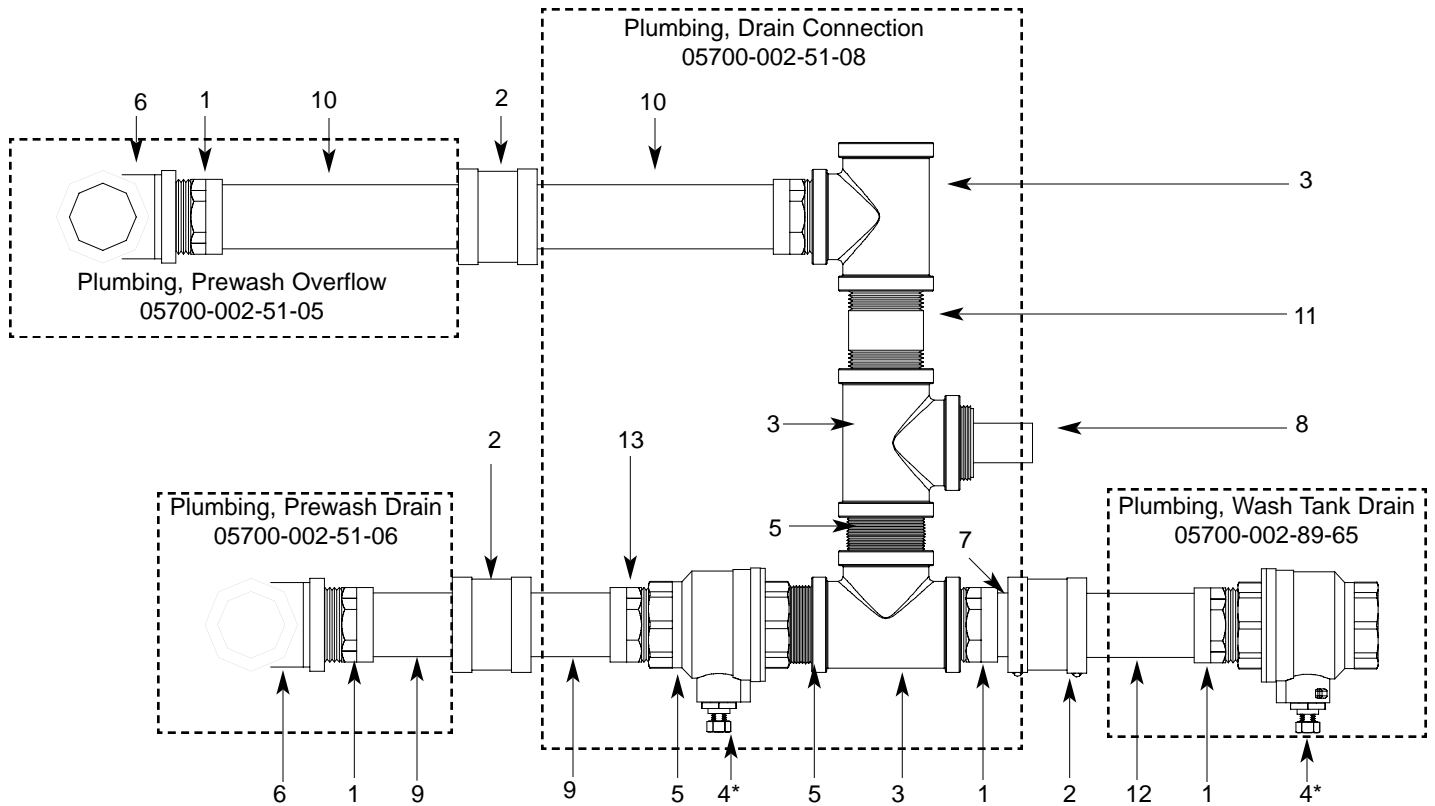

ITEM	QTY	DESCRIPTION	Mfg. No.
1	6	Adapter, Male to Female, 1-1/2"	04730-401-25-01
2	3	No-Hub Connector	4720-604-06-00
3	3	Tee, Brass, 1-1/2" FNPT	04730-011-69-93
4	2	Ball Valve, 1-1/2" FNPT	04820-011-71-46
*	2	Valve Handle Weldment Assembly (Not Shown)	05700-021-84-74
5	2	Nipple, Brass, Close, 1-1/2" NPT	04730-207-40-00
6	2	Elbow, Brass, 90°, 1-1/2" FNPT	04730-011-73-77
7	1	Tube, Copper, 1-1/2" x 1-3/4" Long	05700-000-75-57
8	1	Rinse Nipple Weldment	05700-021-84-61
9	2	Tube, Copper, 1-1/2" x 3-1/2" Long	05700-011-84-23
10	2	Tube, Copper, 1-1/2" x 7-1/2" Long	05700-002-50-98
11	1	Nipple, Brass, 1-1/2" NPT x 3" Long	04730-011-87-04
12	1	Tube, Copper, 1-1/2" x 4-1/4" Long	05700-011-88-40
1	1	Entire Assembly	05700-002-89-64

SECTION 6: PARTS SECTION
DRAIN QUENCH SYSTEM

Drain Quench Assembly
06401-002-44-07

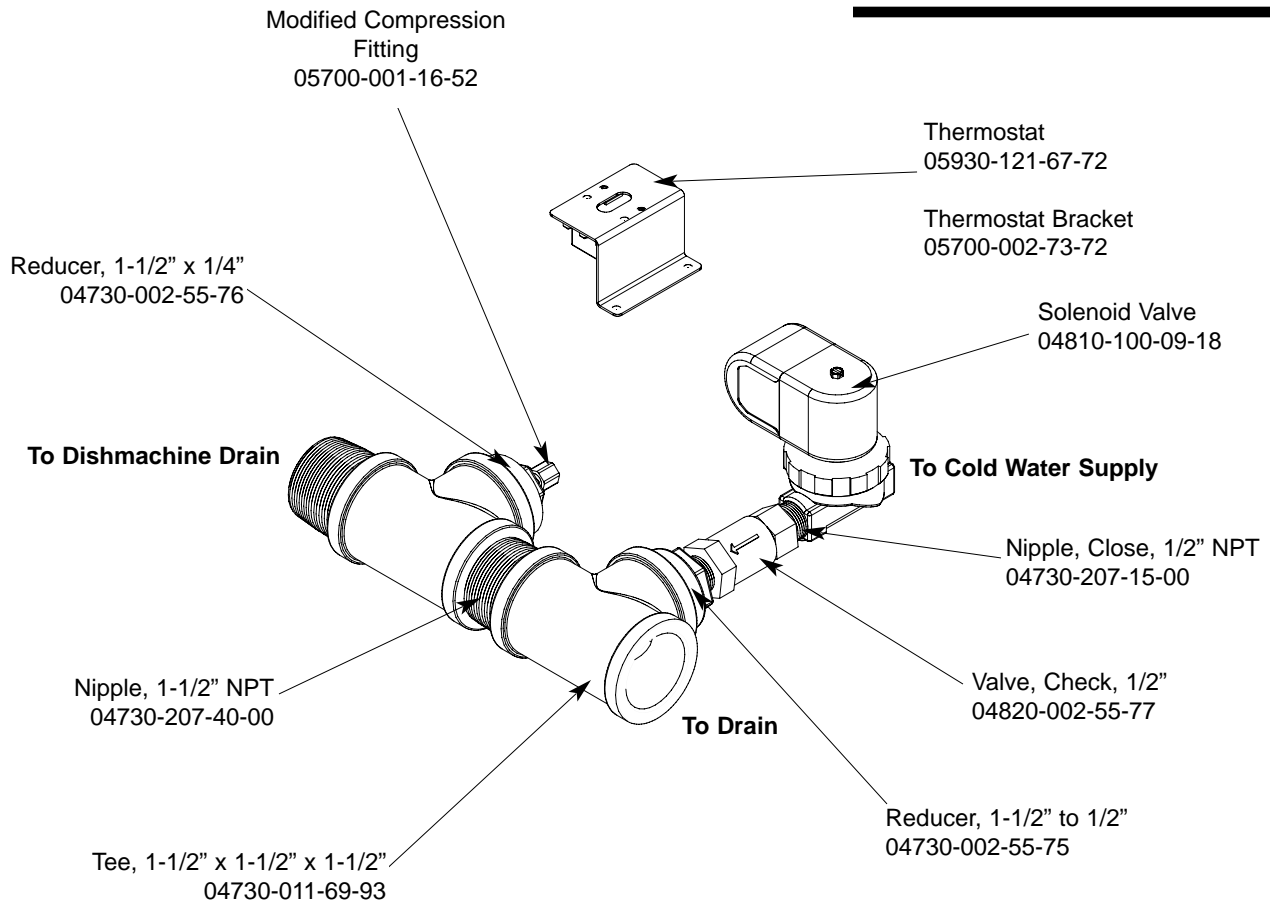

From the existing drain, attach the two additional Tees (Item 7) using the 1-1/2" NPT Close Nipples (Item 8). Tighten the Reducers (Items 6 & 9) into the Tees as shown above. Attach the Modified Compression Fitting (Item 10) into the 1-1/2" to 1/4" Reducer (Item 9). Position the bulb of the thermostat (Item 1) so that it rests approximately 1/4" from the bottom of the Tee (Item 7). Tighten the Modified Compression Fitting (Item 10) as required.

Mount the Thermostat (Item 1) to the tub using the Thermostat Bracket (Item 2) and set it for 120°F - 140°F. Install the Solenoid Valve (Item 3) to the second Tee (Item 7) and then attach to the incoming cold water line. Use pipe dope or thread tape as required to prevent any leaks.

SECTION 6: PARTS SECTION

MOTOR ASSEMBLIES

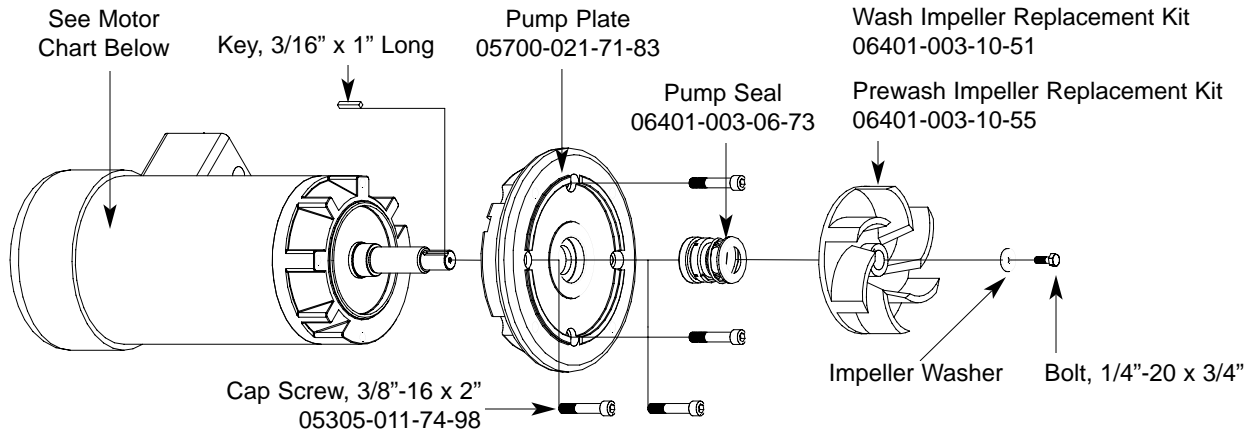

Replacement Kit Notes:

The impeller replacement kits come with the impeller, washer, key and bolt. The motor kits come with everything detailed above as well as two new mounting gaskets.

Clamp, 4 1/8" - 7" (Not Shown)
04730-002-32-15

Kit, Motor Brkt Replace
06401-021-73-42

WASH MOTOR CHART

<u>Volts</u>	<u>Phase</u>	<u>Hz</u>	<u>Motor Part Number</u>	<u>Kit Part Number</u>
208 - 230	1	60	06105-021-70-57	06401-003-09-97
200 - 230	3	60	06105-121-70-58	06401-003-09-98
460	3	60	06105-121-70-58	06401-003-09-98
575	3	60	06105-002-48-31	06401-003-09-99
600	3	60	06105-002-48-31	06401-003-09-99

PREWASH MOTOR CHART

<u>Model(s)</u>	<u>Volts</u>	<u>Phase</u>	<u>Hz</u>	<u>Part Number</u>	<u>Kit Part Number</u>
AJ-76's	208	1	60	06105-121-70-55	06401-003-10-40
	230	1	60	06105-121-70-55	06401-003-10-40
	200	3	60	06105-121-70-56	06401-003-10-38
	220	3	60	06105-121-70-56	06401-003-10-38
	230	3	60	06105-121-70-56	06401-003-10-38
	460	3	60	06105-121-70-56	06401-003-10-38
	575	3	60	06105-002-48-31	06401-003-10-41
AJ-90's	600	3	60	06105-002-48-31	06401-003-10-41
	208	1	60	06105-121-70-57	06401-003-10-42
	230	1	60	06105-121-70-57	06401-003-10-42
	200	3	60	06105-121-70-58	06401-003-10-43
	220	3	60	06105-121-70-58	06401-003-10-43
	230	3	60	06105-121-70-58	06401-003-10-43
	460	3	60	06105-121-70-58	06401-003-10-43
575	3	60	06105-002-48-31	06401-003-10-41	
600	3	60	06105-002-48-31	06401-003-10-41	

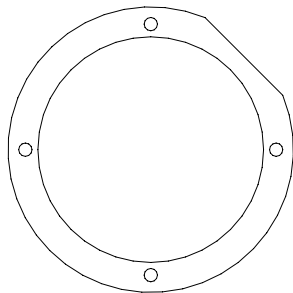
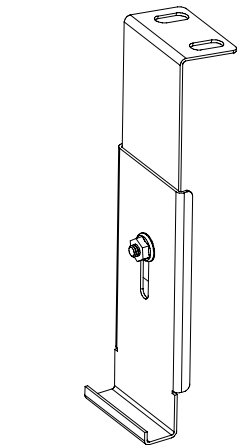

Motor Mounting Gasket
06401-003-06-75

SECTION 6: PARTS SECTION
PREWASH & WASH PUMP WELDMENTS

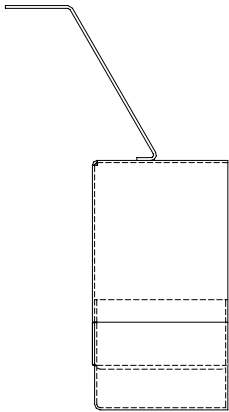

Intake Suction Scoop Weldment
 05700-021-87-60

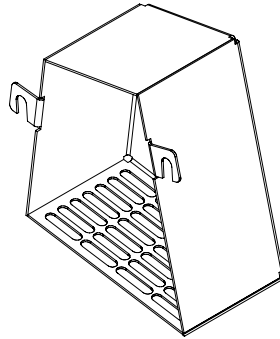

Prewash Intake
 Strainer Weldment
 05700-021-74-96

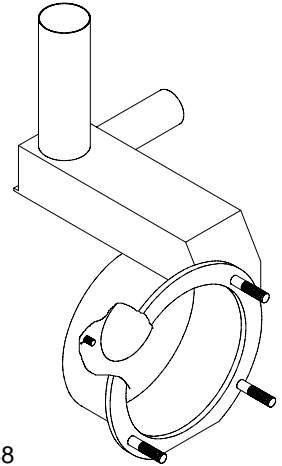

Wash Pump
 Weldment
 05700-041-68-88

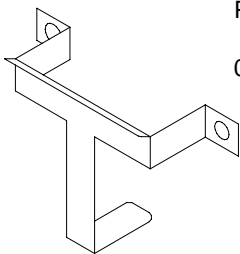

Prewash Strainer
 Bracket
 05700-021-74-94

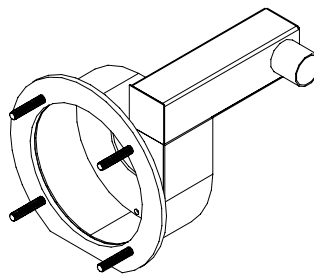

Prewash Pump Weldment
 AJ-76/AJ-90 Left to Right models:
 05700-002-10-62

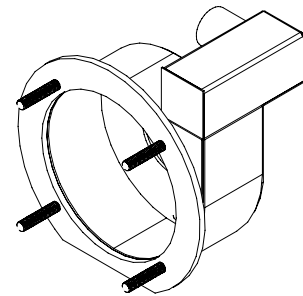

Prewash Pump Weldment
 AJ-76/AJ-90 Right to Left models:
 05700-002-11-96

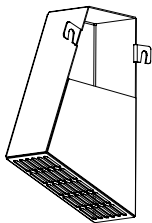

Scoop, Intake Suction Wash
 Weldment
 05700-002-51-20

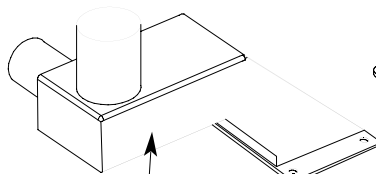

Pump Discharge
 Weldment
 05700-002-50-90

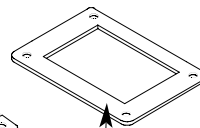

Gasket
 05330-002-54-55

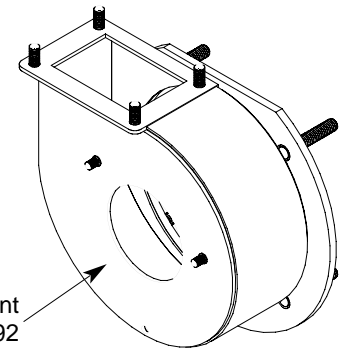

Wash Pump Weldment
 05700-002-50-92

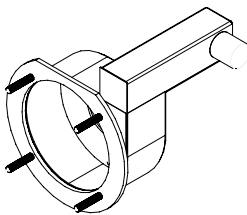

Prewash Pump Weldment
 AJ-76CGP Left to Right model
 05700-002-43-56

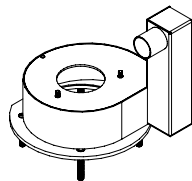

Prewash Pump Weldment
 AJ-76CGP Right to Left model
 05700-002-42-69

SECTION 6: PARTS SECTION
PREWASH ARM/UPPER WASH ARM ASSEMBLY

Replacement Kit Note:
 The replacement kit for the end cap includes the endcap, lanyard, mounting screw and the locknut.

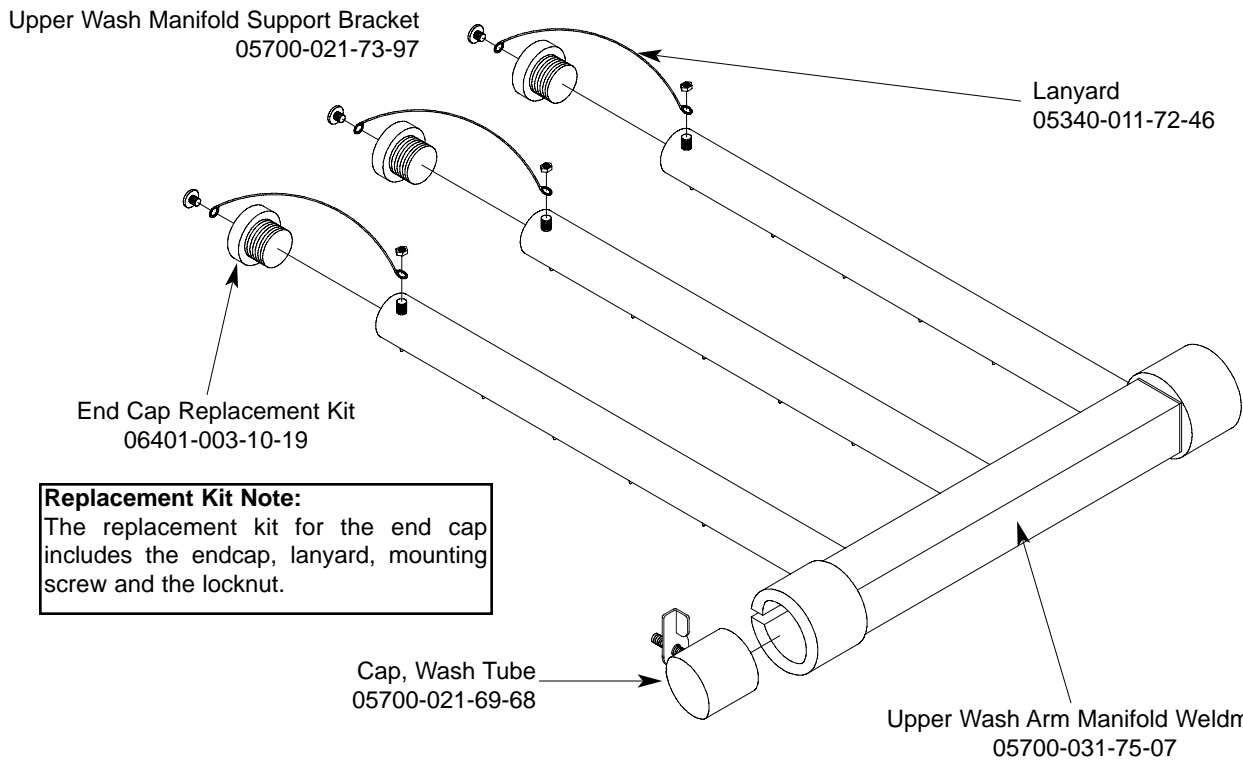
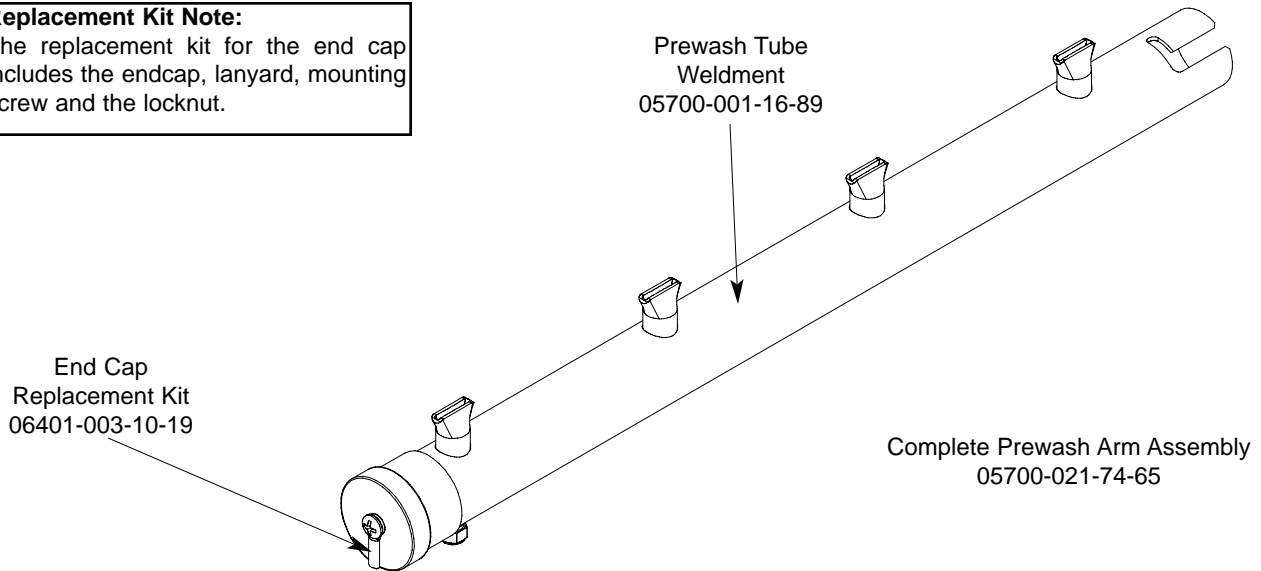

Replacement Kit Note:
 The replacement kit for the end cap includes the endcap, lanyard, mounting screw and the locknut.

Service Note:
 When replacing the 10-32 screws in the End Caps, it is recommended that a thread locking fluid be used to ensure that the screws do not back out during normal operation.

Complete Upper Arm Assembly
05700-031-75-33

SECTION 6: PARTS SECTION

LOWER WASH ARM ASSEMBLY

Lower Wash Arm Support Bracket
05700-011-71-20
Secured with Locknut, 1/4"-20 with Nylon Insert
05310-374-01-00

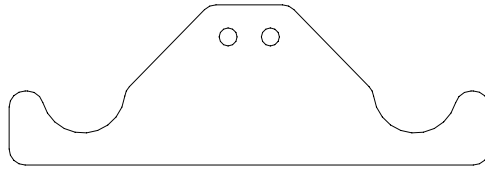

Screw, 10-32 x 3/8" Truss Head
05305-173-12-00

Replacement Kit Note:

The replacement kit for the end cap includes the end-cap, lanyard, mounting screw and the locknut.

End Cap Replacement Kit
06401-003-10-19

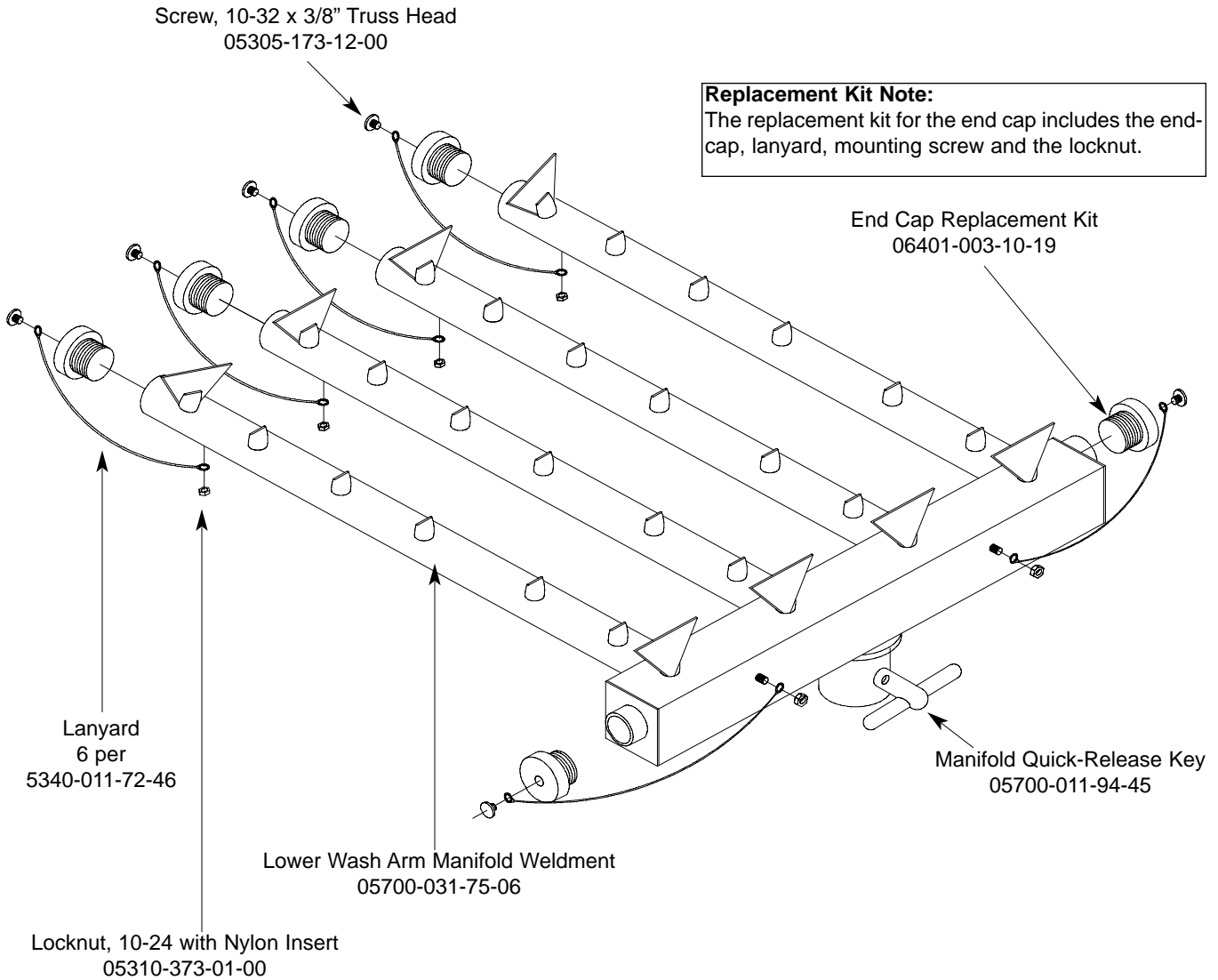

Lanyard
6 per
5340-011-72-46

Lower Wash Arm Manifold Weldment
05700-031-75-06

Manifold Quick-Release Key
05700-011-94-45

Locknut, 10-24 with Nylon Insert
05310-373-01-00

**Complete Lower Wash Arm Assembly
05700-031-75-32**

SERVICE NOTE: When replacing the 10-32 screws in the End Caps, it is recommended that a thread locking fluid be used to ensure that the screws do not back out during normal operation.

SECTION 6: PARTS SECTION
CURTAINS/TUB MAGNETS

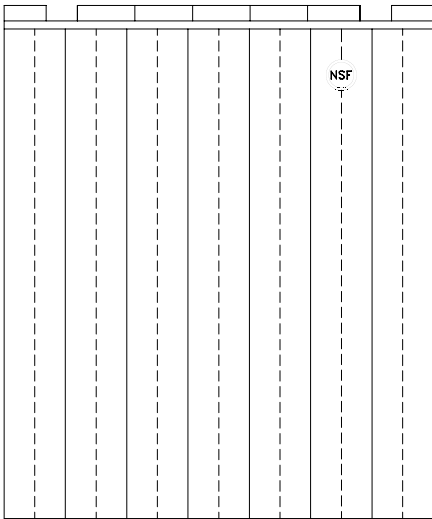

Curtain, 24 1/2" Long x 20-1/2" Wide
CGP MODELS ONLY
08415-002-47-37

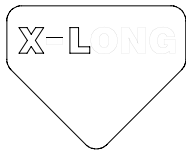

Extra Long Curtain Decal
CGP MODELS ONLY
09905-002-52-69

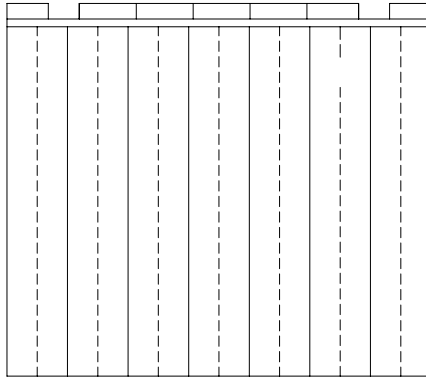

Curtain, 21" Long x 20-1/2" Wide
08415-131-73-45

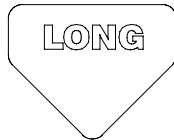

Long Curtain Decal
09905-011-73-84

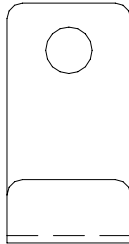

Curtain Hook
05700-011-83-54

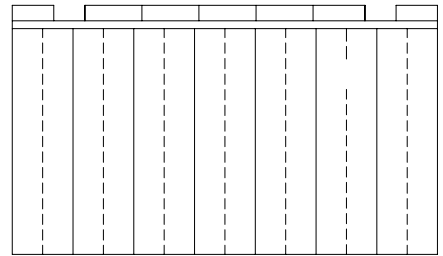

Curtain, 12" Long x 20-1/2" Wide
08415-131-73-44



Short Curtain Decal
09905-011-73-82

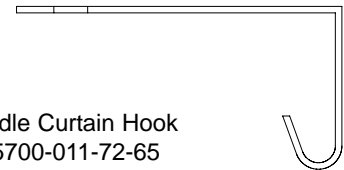

Middle Curtain Hook
05700-011-72-65

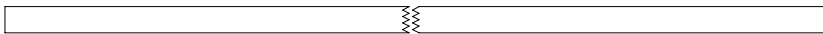

Curtain Rod
05700-021-73-43

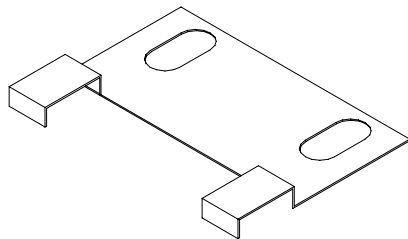

Limit Switch Bracket
05700-021-71-18

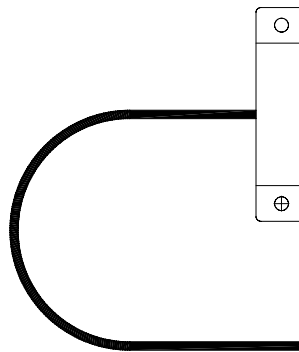

Conveyor Switch Replacement Kit
06401-003-11-79

Replacement Kit Note:
The conveyor switch replacement kit comes with the switch, a terminal and a wire nut.

Service Note:
The cord for the conveyor switch needs to be cut to length in the field and have the pink terminal applied there.

SECTION 6: PARTS SECTION

FINAL RINSE ASSEMBLY

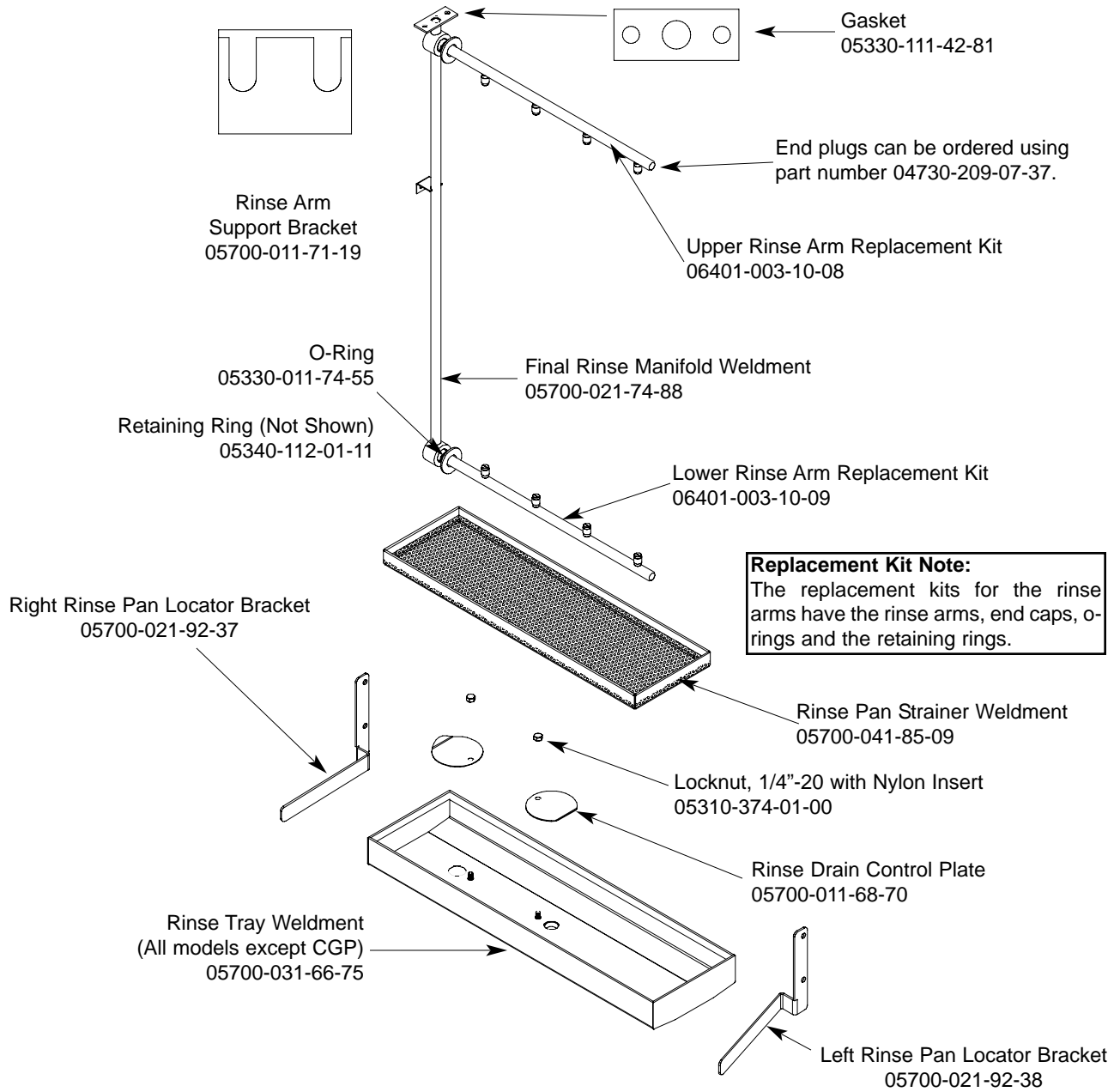

Optional Parts for CGP Models

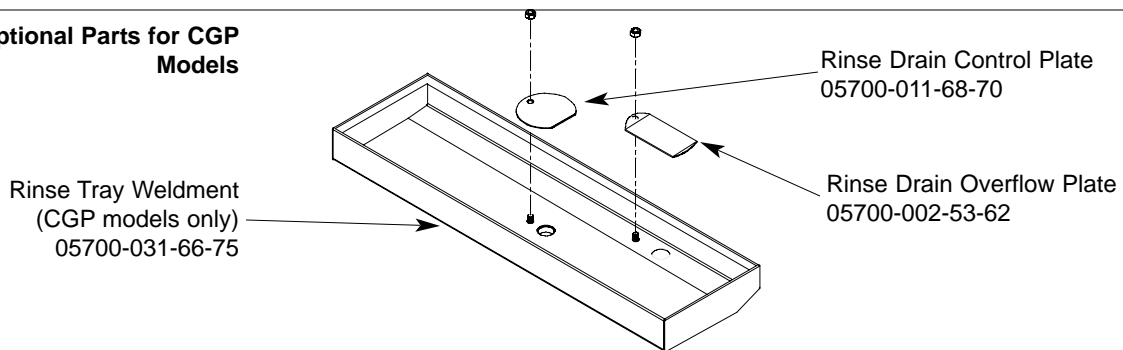

SECTION 6: PARTS SECTION
DRIVE ASSEMBLY

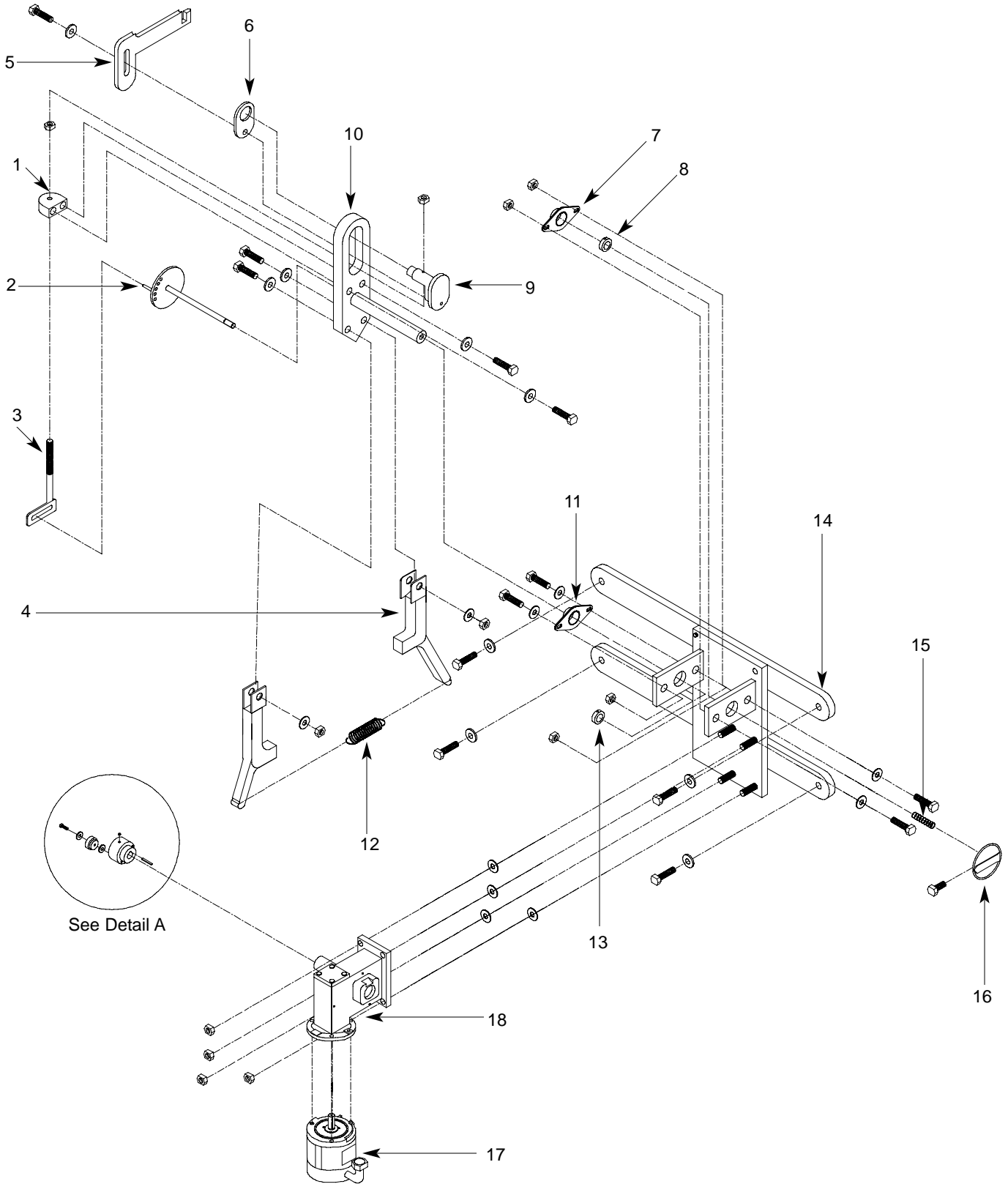

SECTION 6: PARTS SECTION

DRIVE ASSEMBLY (CONTINUED)

ITEM	QTY	DESCRIPTION	Mfg. No.
1	1	Drive Plate and Rod Weldment	05700-021-67-44
		Replacement Kit with Expansion Legs	06401-021-86-80
		Replacement Kit with Expansion Legs/Adjuster Crank	06401-011-94-54
2	1	Adjuster Crank Assembly	05700-021-69-95
3	1	Scotch Yoke Weldment Replacement Kit	06401-003-08-48
4	2	Coupling & Expansion Leg Weldment	05700-021-67-50
5	1	Pawl Bar Drive Linkage Casting	09515-021-87-73
6	1	Spacer Plate	05700-011-67-58
7	2	Pillow Block Replacement Kit	06401-003-08-50
8	2	Shaft Collar	05700-011-89-18
9	1	Drive Socket	05700-021-67-39
10	1	Drive Plate	05700-021-67-42
11	2	Pillow Block	03120-021-71-87
12	1	Drive Spring	05315-011-83-51
13	2	Shaft Collar	05700-011-89-18
14	1	Drive Motor Mounting Bracket	05700-031-73-56
15	1	Adjuster Spring	05315-011-71-90
16	1	Adjusting Handle Weldment	05700-021-72-28
17	1	Drive Motor Replacement Kits	
		Drive Motor (50 Hz Models)	06401-003-08-41
	1	Drive Motor (208-230 Volt, 60 Hz, Single Phase Models)	06401-003-08-42
		Drive Motor (208-230 Volt, 60 Hz, Three Phase Models)	06401-003-08-40
		Drive Motor (600 Volt, 60 Hz, Three Phase Models)	06401-003-08-43
18	1	Gear Drive	06105-011-87-20
19	1	Roller Bearing	03120-011-71-81
20	1	Drive Hub	05700-011-67-97

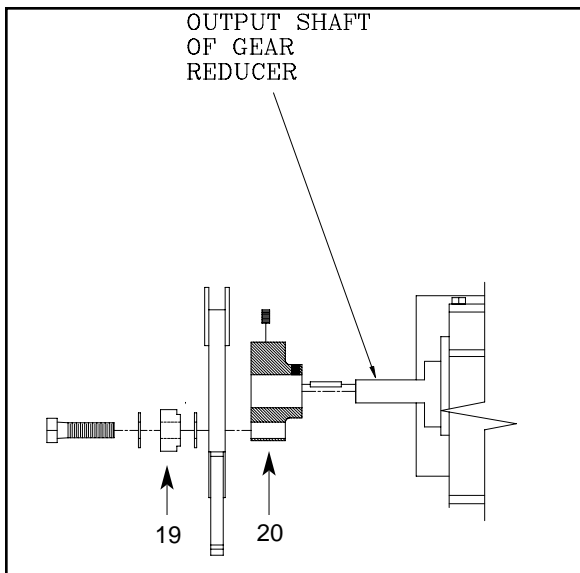

Detail A

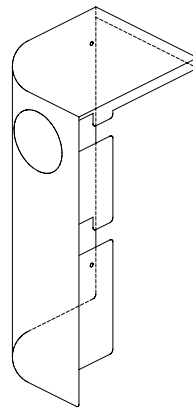

Front Drive Motor Cover
Replacement Kit
06401-003-11-64

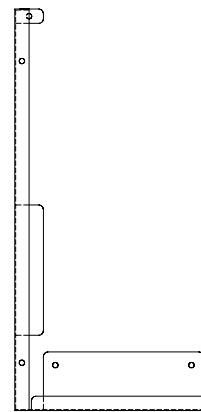

Rear Drive Motor Cover
Replacement Kit
06401-003-10-18

Replacement Kits Notes:

The replacement kits for the drive motor covers come with the weldments and the mounting hardware.

SECTION 6: PARTS SECTION

LUBRICATION CHART FOR DRIVE GEAR

Note: The maintenance procedures detailed here are manufacturer's instructions for the WINSMITH brand of gear reducer that is installed on the rack conveyors covered in this manual.

Ambient Temperature	-30 - 15°F	16 - 50°F	51 - 95°F	51 - 95°F	96 - 131°F	96 - 131°F
Final Stage Worm Speed ¹	up to 2000 FPM	up to 2000 FPM	up to 450 FPM	above 450 FPM	up to 450 FPM	above 450 FPM
ISO Viscosity Grade	220	460	680	460	680	460 ¹
AGMA Lubricant No.	5S	#7 Compounded	#8 Compounded	#7 Compounded	8S	7S
Mobil	SHC 630	600W Super Cylinder	Extra Hecla Super	600W Super Cylinder	SHC 636	SHC 634
American Lubricants	SHC-90W	AGMA #7 Gear Oil	AGMA #8 Gear Oil	AGMA #7 Gear Oil	N/A	N/A
Castrol	Tribol 800/220	Tribol 1105-7C	Tribol 1105-8C	Tribol 1105-7C	Tribol 800/680	Tribol 800/460
Chevron	Tegra 220	Cylinder Oil W460	Cylinder Oil W680	Cylinder Oil W460	Tegra 680	Tegra 460
Conoco	Syncon R & O 220	Inca Oil 460	Inca Oil 680	Inca Oil 460	N/A	Syncon R & O 460
Exxon (Esso)	Teresstic SHP220	Spartan EP 460	Spartan EP 680	Spartan EP 460	Teresstic SHP 680	Teresstic SHP 460
Fiske Brothers	SPO-MG	SPO-277	SPO-288	SPO-277	N/A	N/A
Shell	Omala RL 220	Valvata J 460	Valvata J 680	Valvata J 460	Omala RL 680	Omala RL 460
Texaco	Pinnacle 220	Vanguard 460	Vanguard 680	Vanguard 460	Pinnacle 680	Pinnacle 460

(1) The sliding velocity in feet per minute (FPM) for standard ratios is determined by multiplying the speed of the worm in RPM by the factor from the table below. For selecting proper lubricant, use the speed of the worm in the final stage (input RPM divided by the first stage ratio).

SECTION 6: PARTS SECTION
DOOR ASSEMBLIES

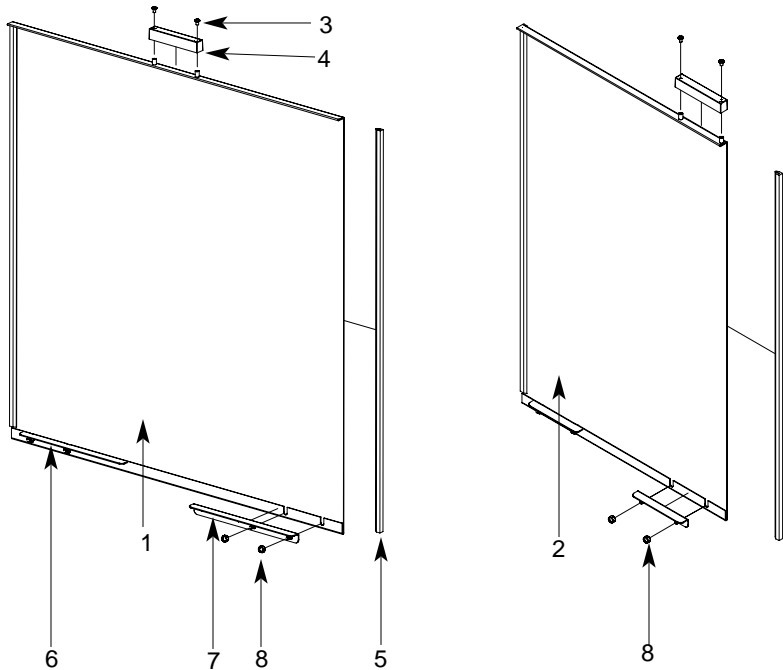

Locknut, 1/4"-20 with Nylon Insert
05310-374-01-00

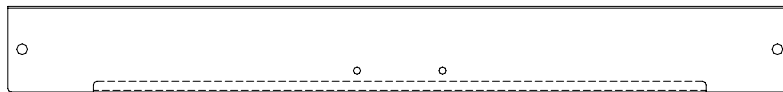

Wash Door Hood Support: 05700-031-84-13
22" Prewash Door Hood Support: 05700-031-84-14

Door Stiffener (Not Shown) 05700-031-83-43

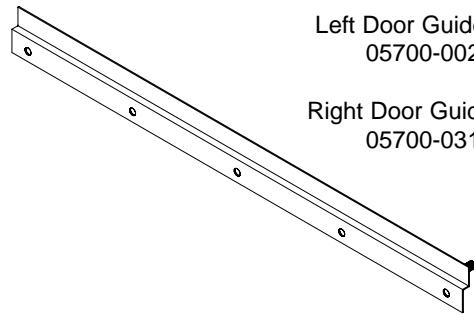

Left Door Guide Weldment
05700-002-32-51

Right Door Guide Weldment
05700-031-76-44

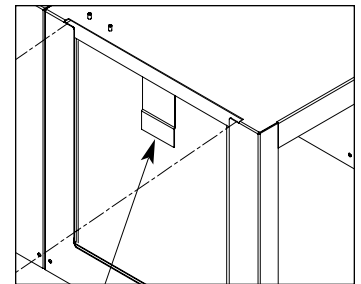

Door Catch Weldment
05700-031-84-80

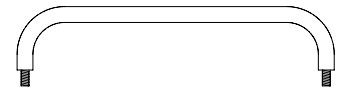

Wash Door Handle Weldment
05700-011-82-63

Prewash Door Handle Weldment
05700-011-80-45

ITEM	QTY	DESCRIPTION	Mfg. No.
1	1	Wash Door Weldment	05700-003-13-35
2	1	Prewash Door Weldment	
		Left to Right Model	05700-003-13-42
		Right to Left Model	05700-003-13-40
3	1	Screw, 8-32 x 1/4" Long	05305-172-09-00
4	1	Door Switch Magnet	05700-111-51-68
5	1	Door Guide	05700-111-70-92
6	1	Door Stop Weldment, Right	05700-002-96-33
7	1	Door Stop Weldment, Left	05700-002-96-32
8	2	Locknut, 10-24 SS Hex with Nylon Insert	05310-373-01-00
9	2	Door Stop Weldment, Prewash	05700-002-05-46

SECTION 6: PARTS SECTION
PAWL BAR MISCELLANEOUS COMPONENTS

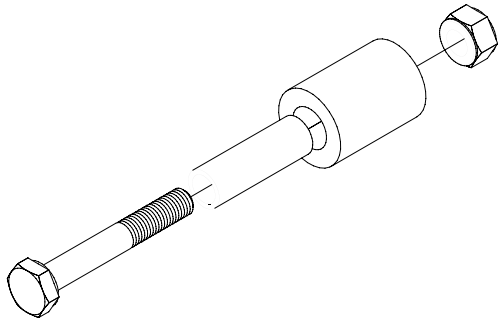

Pawl Bar Roller Replacement Kit
 06401-003-11-80

Replacement Kit Notes:

The replacement kit for the pawl bar roller comes with the roller, roller shaft, hardware and locknut as shown.

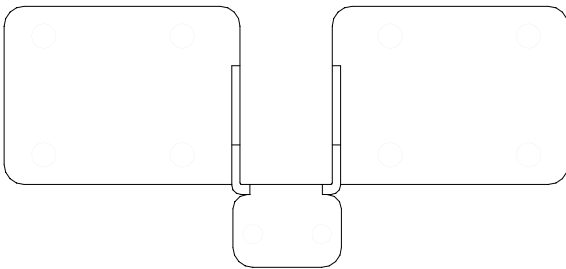

Pawl Bar Bracket (without tabs) Weldment
 05700-031-92-36

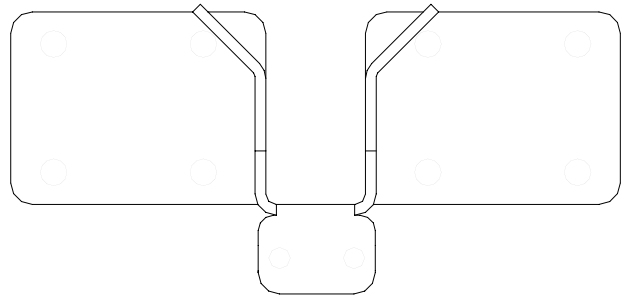

Pawl Bar Bracket (with studs) Weldment
 05700-031-84-68

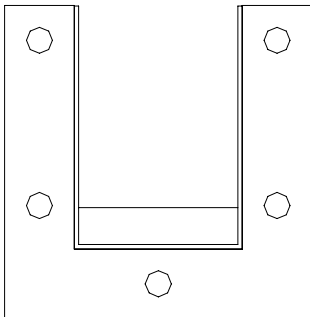

Pawl Bar Gutter Weldment Replacement Kit
 06401-003-09-95

Replacement Kits Notes:

The pawl bar gutter weldment replacement kit contains the weldment, a gasket and the mounting hardware. The guide block kit contains both blocks and a gasket.

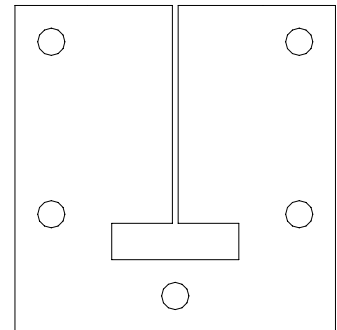

Pawl Bar Gutter Gasket
 05330-011-68-55

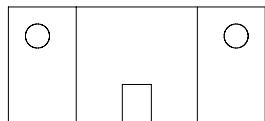

Top Guide Block

Guide Block Replacement Kit
 06401-003-10-15

Bottom Guide Block

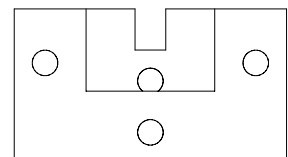

Service Note: It is highly recommended that when changing out one guide block, that the other be changed out as well, along with the gasket.

SECTION 6: PARTS SECTION

AJ-54 PAWL BAR ASSEMBLY

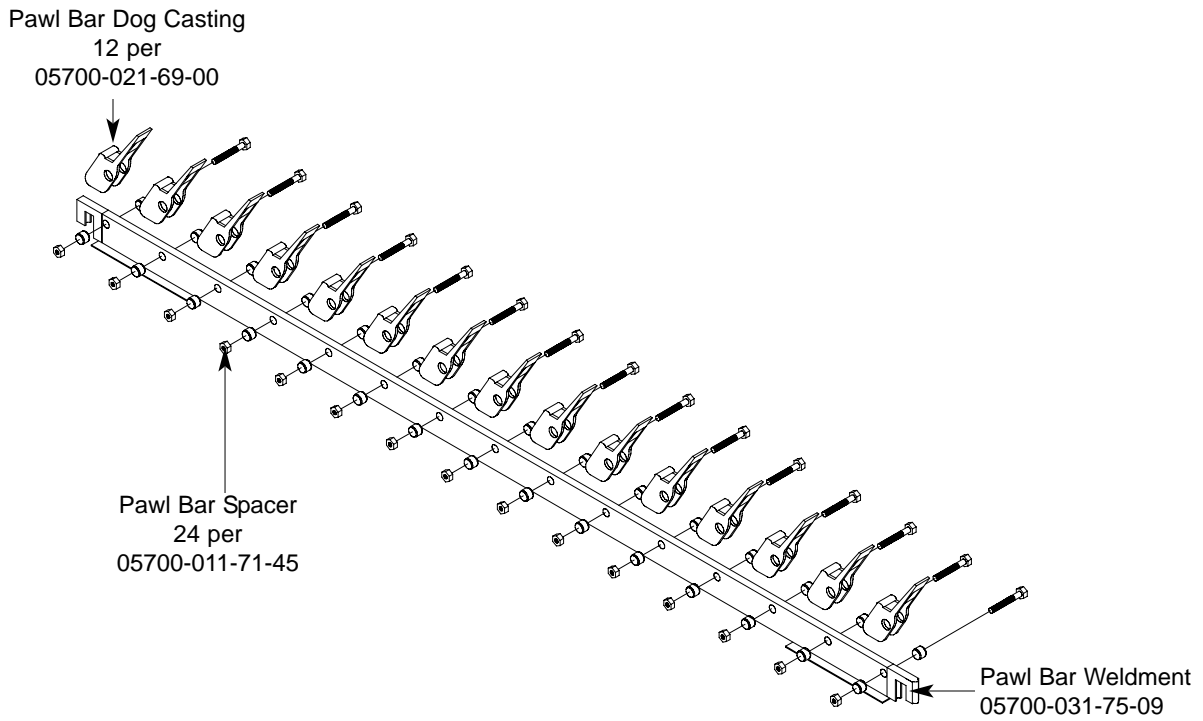

AJ-54 Complete Assembly with Hardware
06401-131-81-01

AJ-54 Prison Assembly with Hardware
06401-231-81-01

SECTION 6: PARTS SECTION

AJ-76 PAWL BAR ASSEMBLIES

Left to Right Assembly

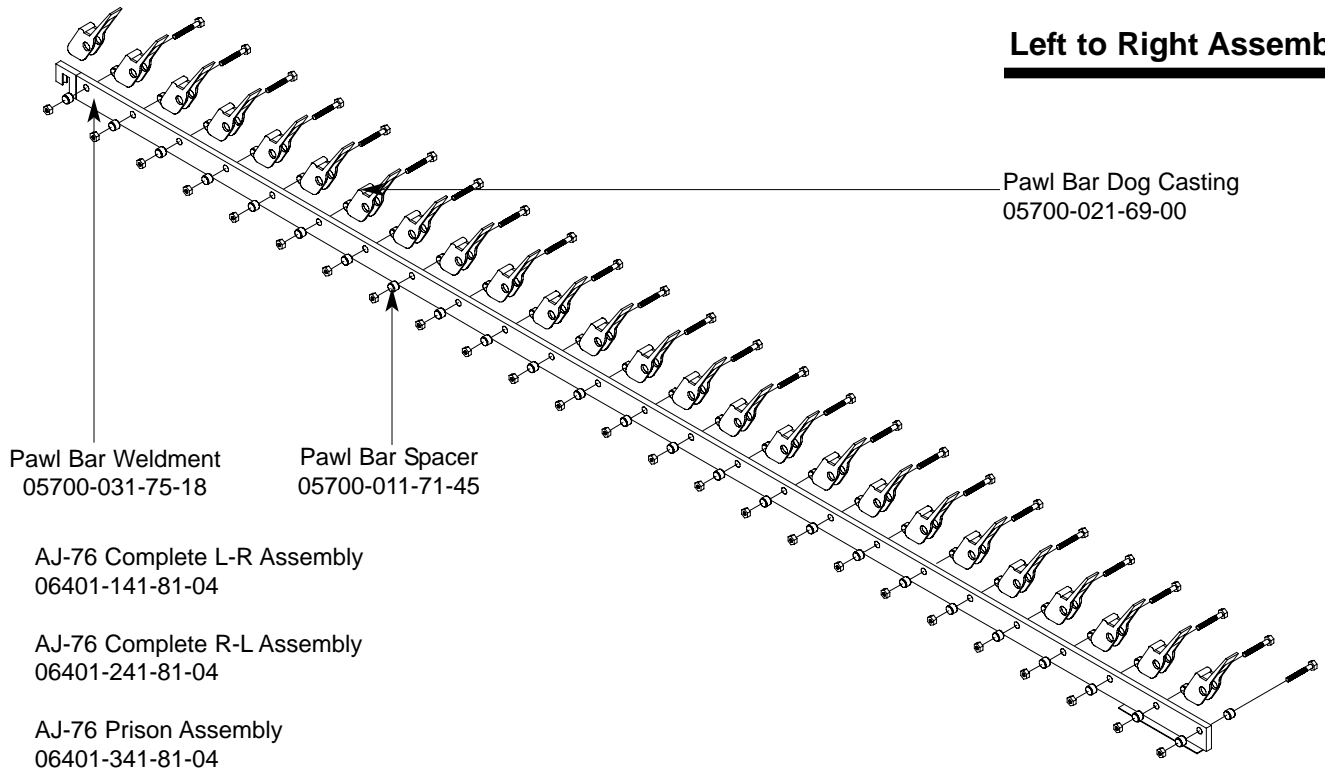

Right to Left Assembly

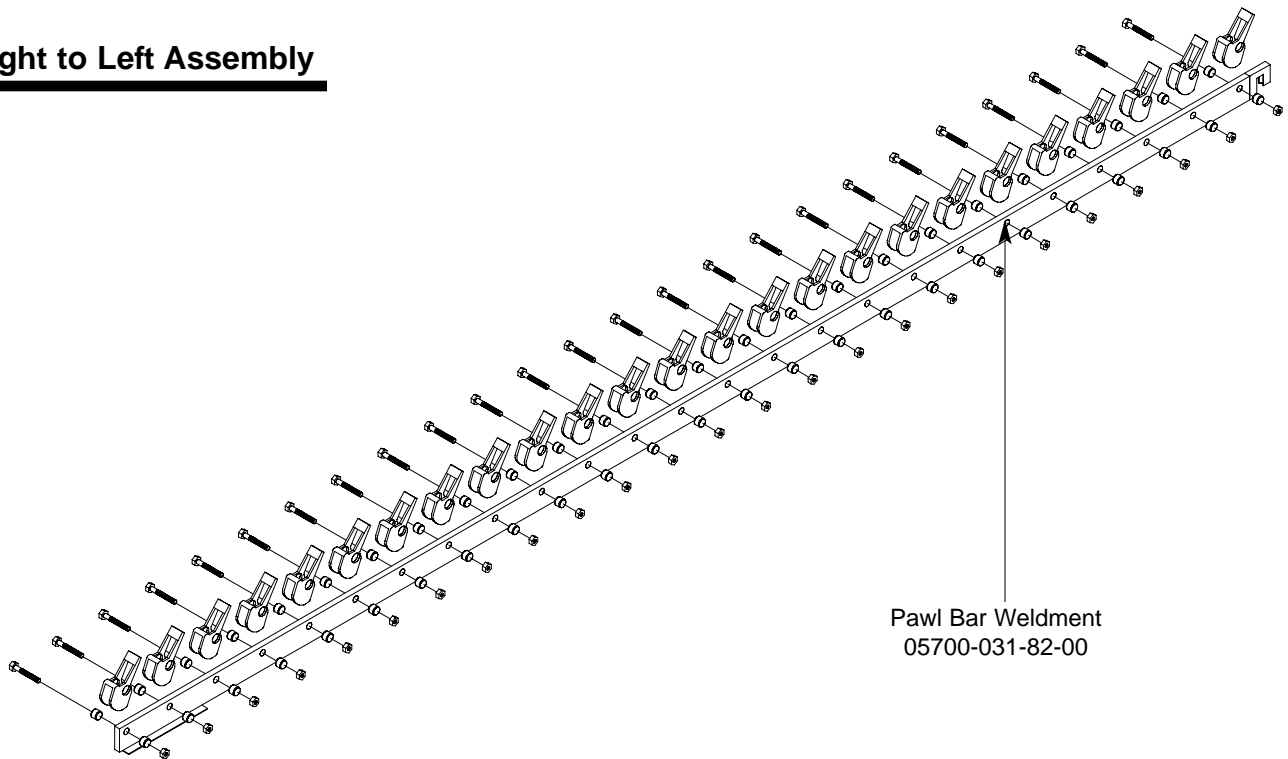

SECTION 6: PARTS SECTION

AJ-90 PAWL BAR ASSEMBLIES

Left to Right Assembly

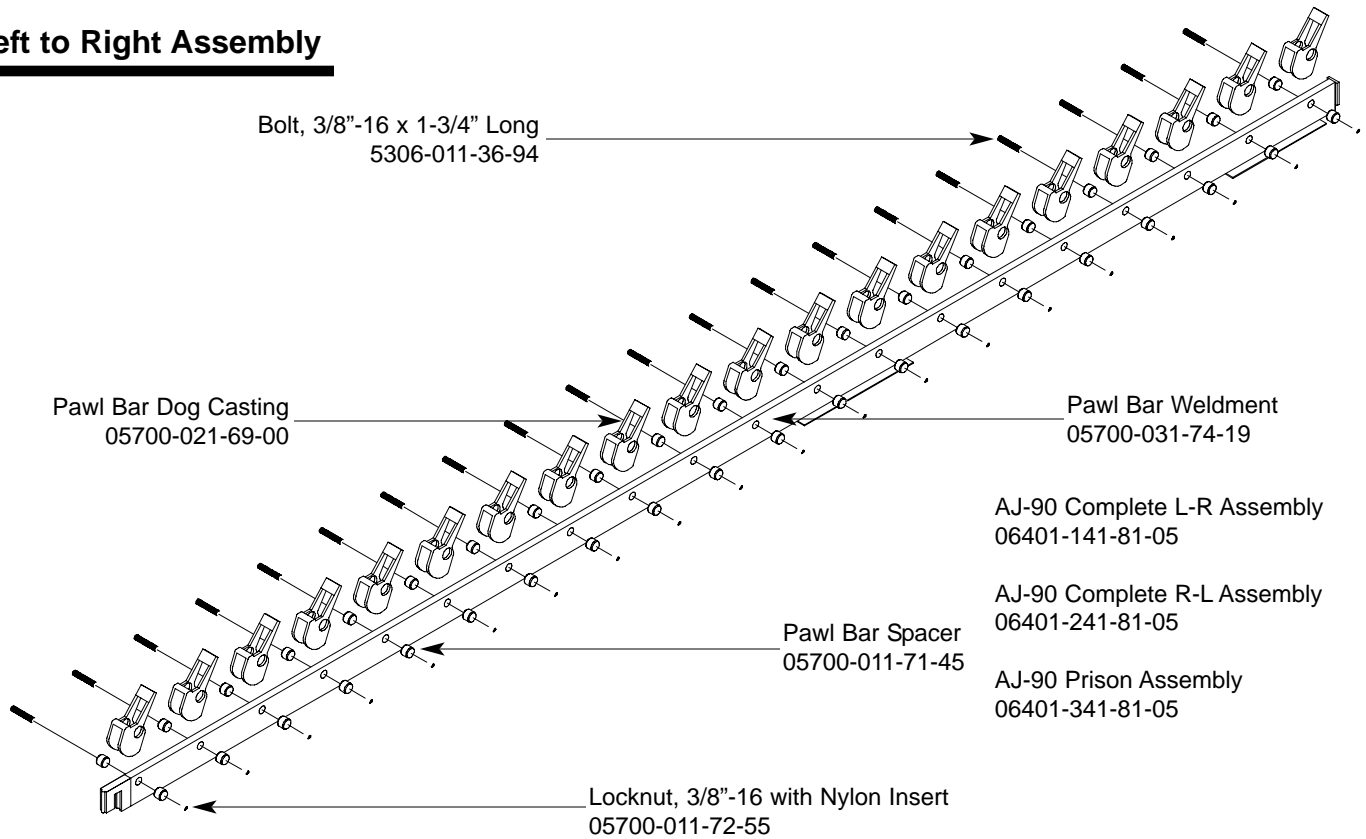

Right to Left Assembly

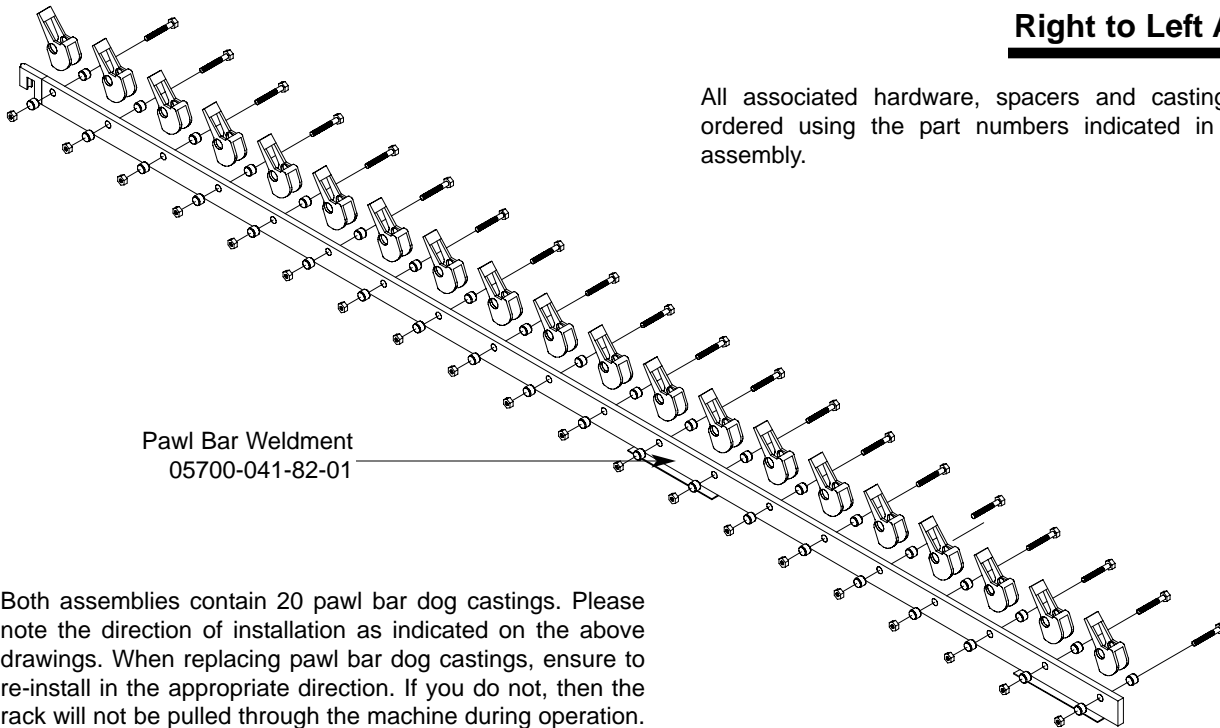

Both assemblies contain 20 pawl bar dog castings. Please note the direction of installation as indicated on the above drawings. When replacing pawl bar dog castings, ensure to re-install in the appropriate direction. If you do not, then the rack will not be pulled through the machine during operation.

SECTION 6: PARTS SECTION

AJ-54 RACK RAIL ASSEMBLY

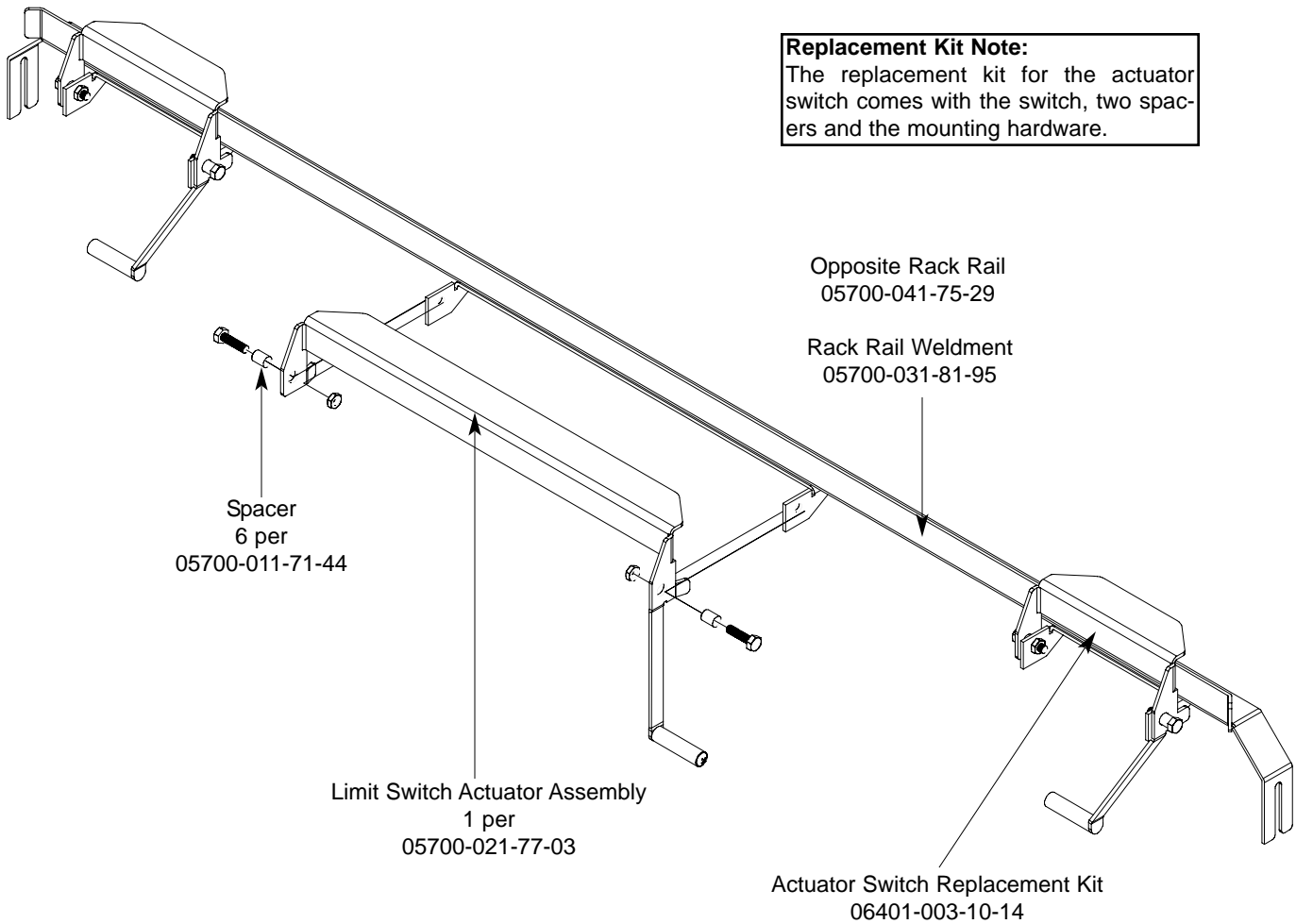

SECTION 6: PARTS SECTION

AJ-76 RACK RAIL ASSEMBLIES

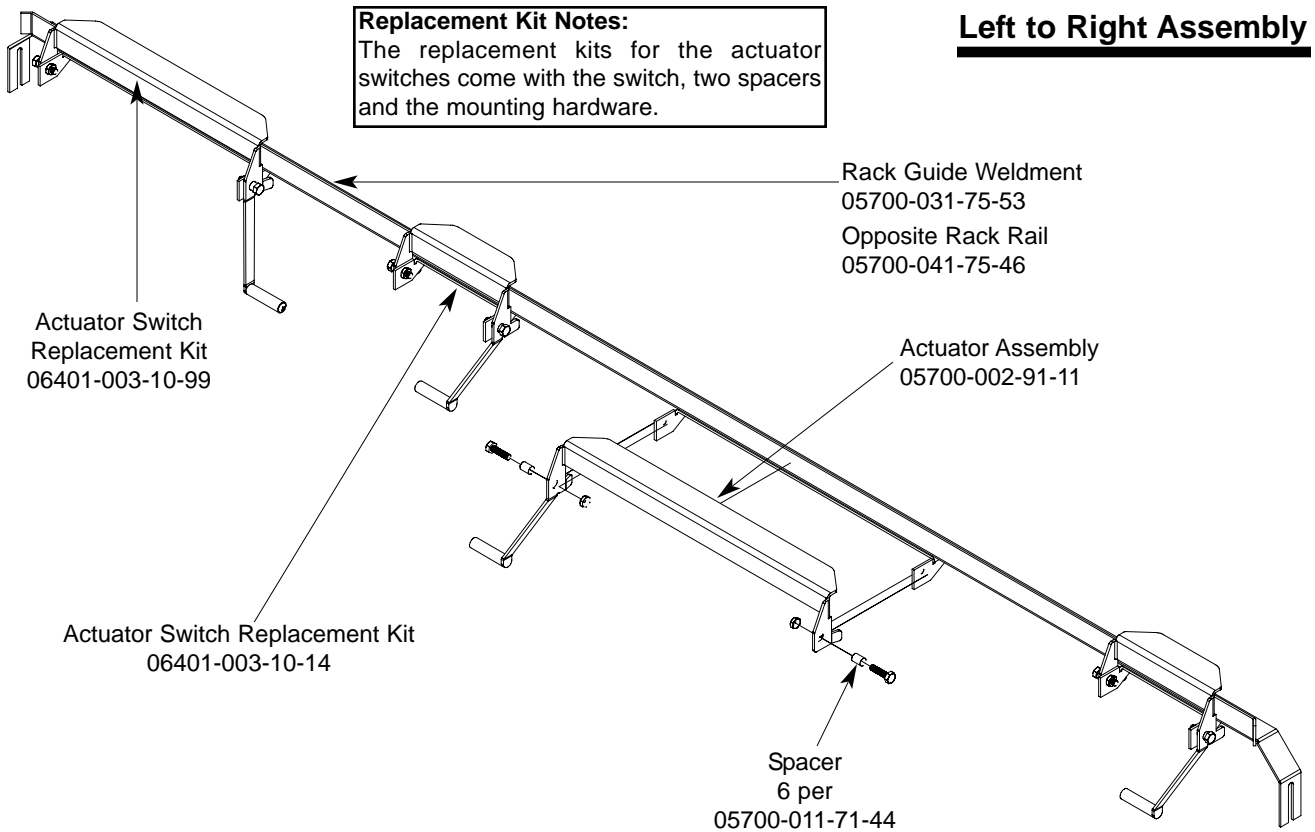

Right to Left Assembly

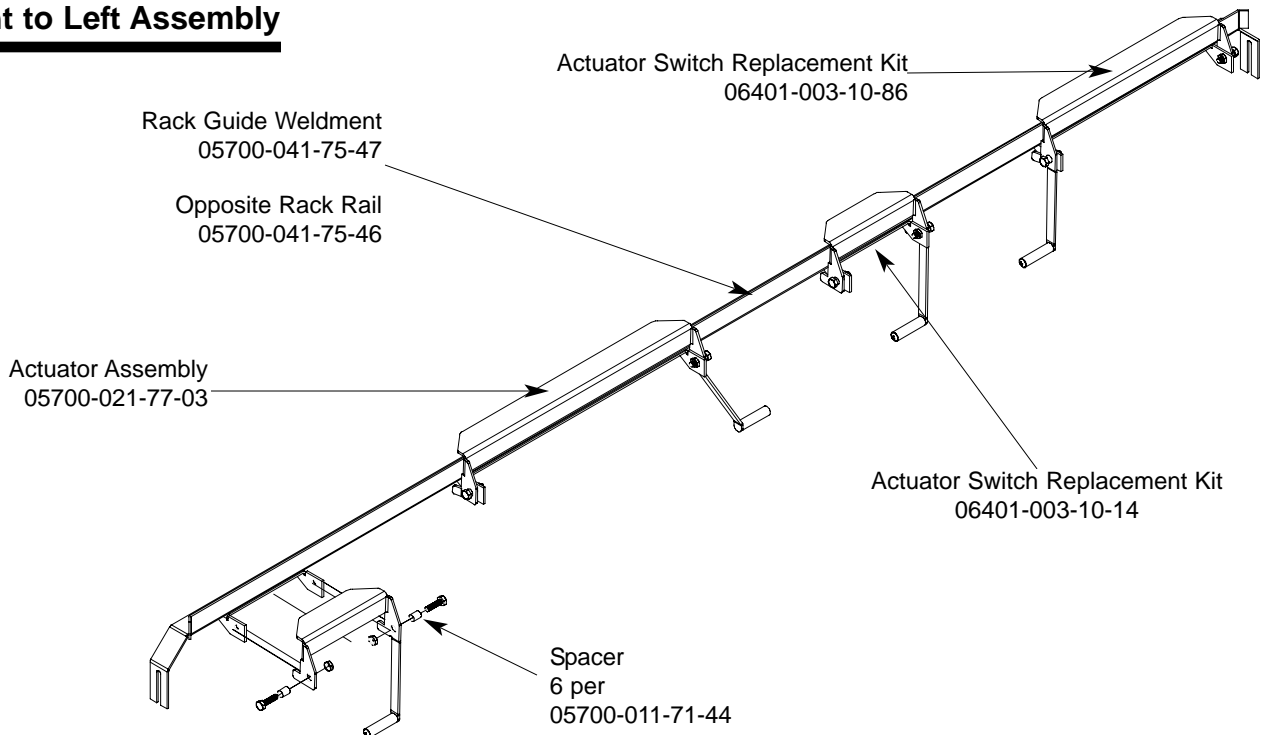

SECTION 6: PARTS SECTION

AJ-90 RACK RAIL ASSEMBLIES

Left to Right Assembly

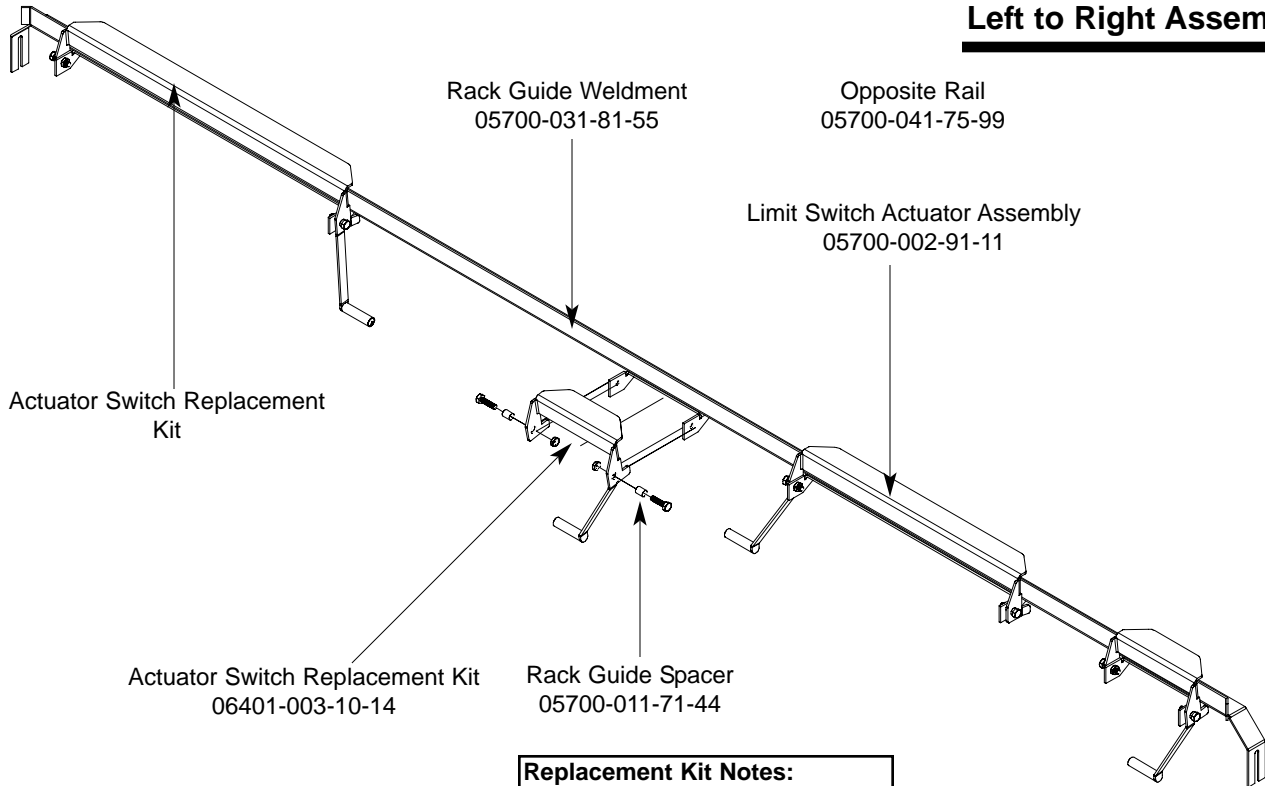

Replacement Kit Notes:

The replacement kits for the actuator switches come with the switch, two spacers and the mounting hardware.

Right to Left Assembly

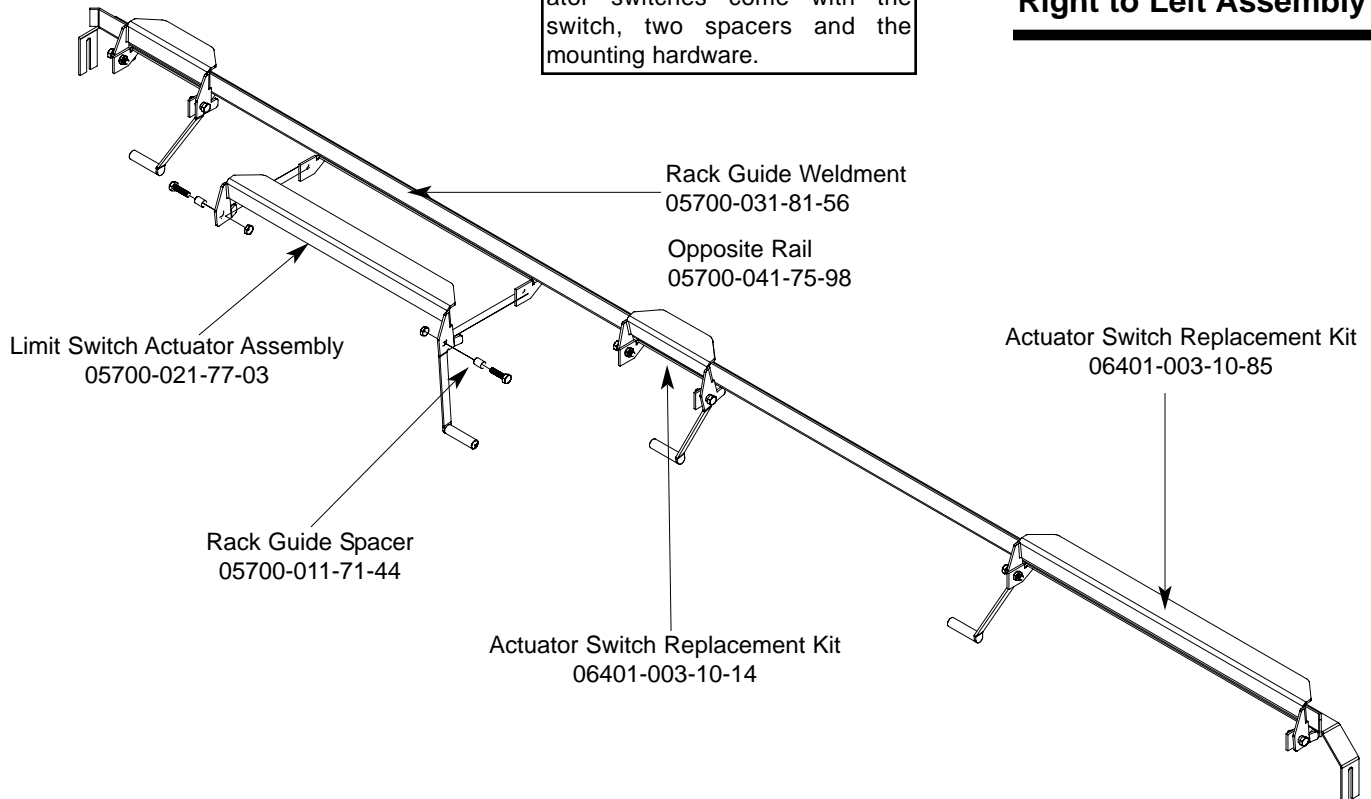

SECTION 6: PARTS SECTION
MISCELLANEOUS PARTS AND WELDMENTS

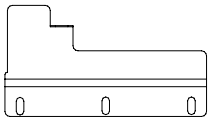

Plate, Left Water Directional
 05700-021-79-27

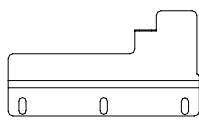

Plate, Right Water Directional
 05700-021-79-23

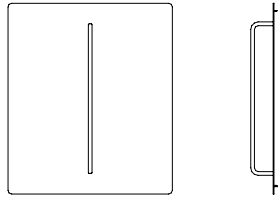

Run Off Sheet Weldment
 05700-021-71-39

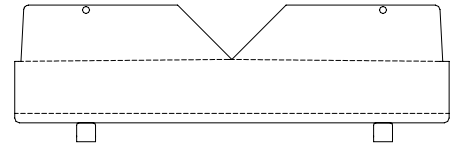

Splash Shield Weldment
 05700-031-85-16

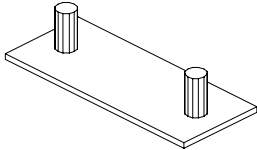

Hole Direction Plate Replacement Kit
 06401-003-10-00

Replacement Kit Note:
 The kit for the hole direction plate comes with the plate, a new gasket and the mounting hardware.

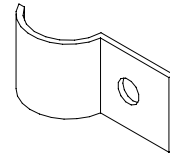

Pipe Clamp
 05700-000-35-05

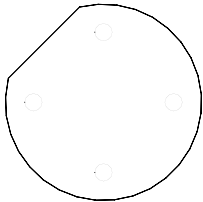

Rinse Drain Plate Replacement Kit
 (CGP Models Only)
 06401-003-10-07

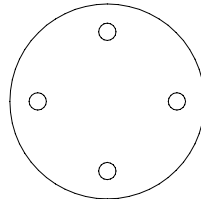

Rinse Drain Plug Replacement Kit
 06401-003-10-06

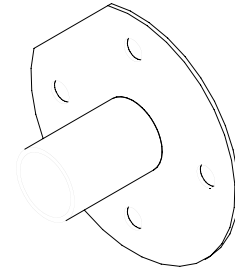

Rinse Drain Weldment Replacement Kit
 06401-003-10-05

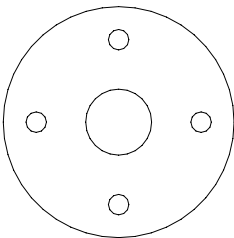

Rinse Drain Plate Gasket
 05330-011-72-27

Replacement Kits Notes:
 The kits for the drain weldments and drain plugs come with the weldments/parts, a new gasket and the mounting hardware.

SECTION 6: PARTS SECTION
MANIFOLDS/STRAINER SUPPORT WELDMENTS

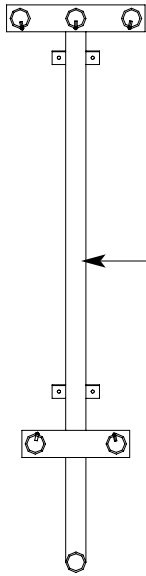

Prewash Manifold Weldment
 AJ-66 Models Only
 05700-031-69-70

Prewash Manifold Weldment
 AJ-80 Models Only
 05700-002-24-94

Prewash Manifold Weldment
 (CGP Models Only)
 05700-002-59-51

Wash Manifold Weldment
 05700-031-71-13

Wash Manifold Weldment
 (CGP Models Only)
 05700-002-51-14

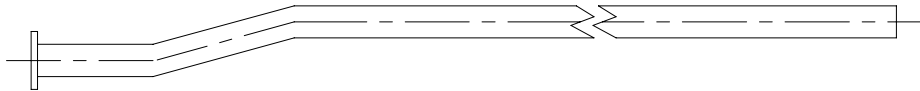
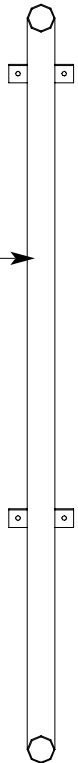

Wash Fill Tube Weldment
 05700-021-71-21

Prewash Fill Tube Weldment
 (AJ-66 & AJ-80 Models Only)
 05700-021-74-76

Vellumoid Gasket
 05330-111-42-81

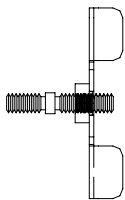

Shoulder Bolt Wingnut Weldment
 05700-002-46-02

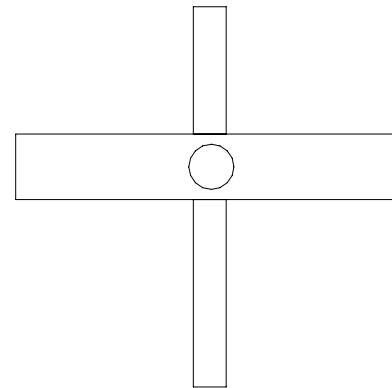

Wash Strainer Separator Weldment
 05700-031-84-38

SECTION 6: PARTS SECTION
STRAINERS

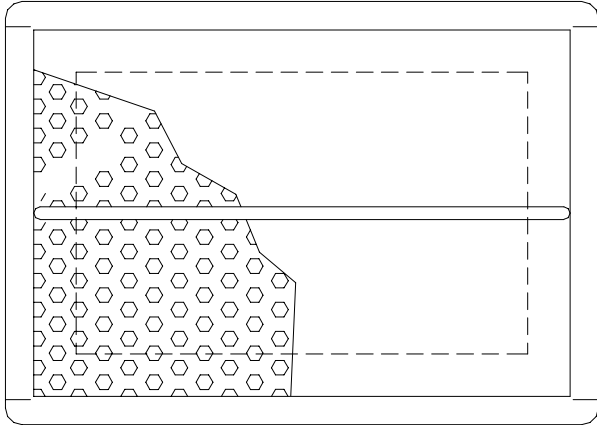

Front Strainer Weldment
05700-021-85-10

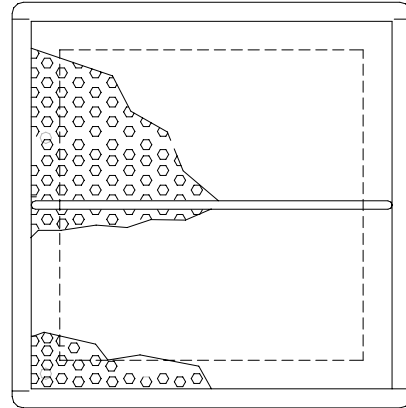

Back Strainer Weldment
05700-021-85-11

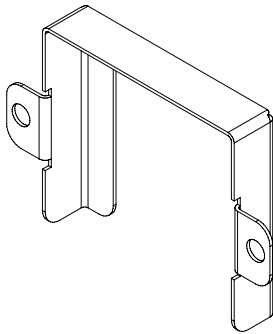

Overflow Strainer Support
05700-001-96-48

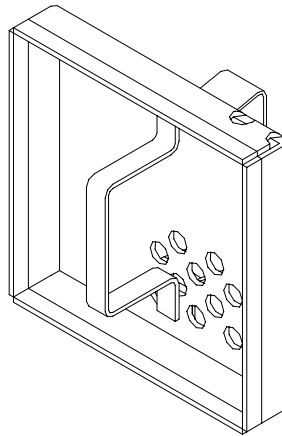

**Drain Guard
Strainer Weldment**
05700-002-09-15

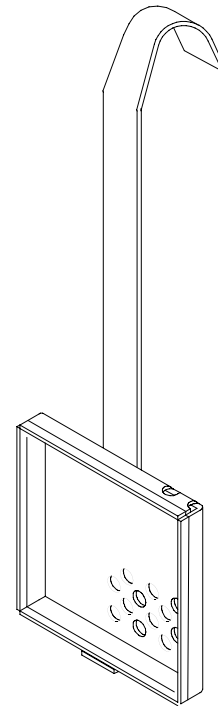

Wash Intake Strainer Weldment (CGP Models)
05700-002-51-52

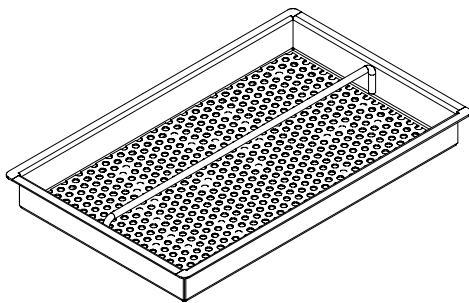

Tub Strainer Weldment (CGP Models)
05700-002-03-21

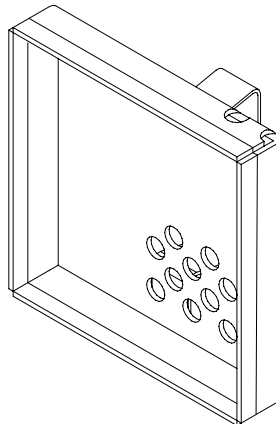

**Screen Strainer
with Handle Weldment**
05700-002-09-04

SECTION 6: PARTS SECTION
FLOAT SWITCH COMPONENTS/SCRAP BASKETS

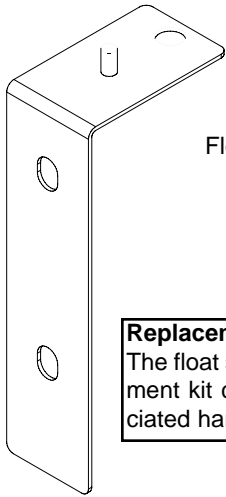

Float Switch Support Bracket
 Replacement Kit
 06401-003-11-77

Replacement Kit Note:
 The float switch support bracket replacement kit contains the bracket and associated hardware for mounting.

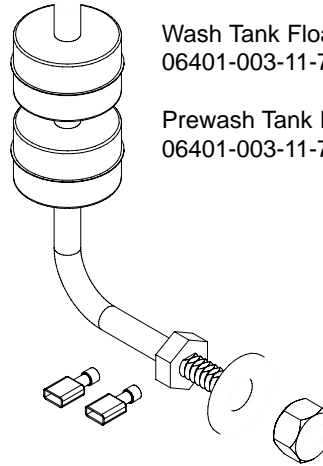

Wash Tank Float Switch Replacement Kit
 06401-003-11-75

Prewash Tank Float Switch Replacement Kit
 06401-003-11-76

Replacement Kit Note:
 The float switch replacement kits contain the float switch with associated terminals, the flat washer and the nut.

Service Agent Note:
 Remember than when reinstalling the float switch that the flat washer goes inside against the tub wall while the nut is on the outside of the tub.

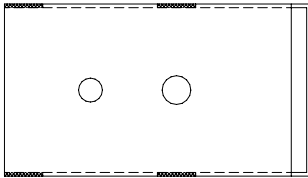

Float Switch Cover
 05700-021-75-71

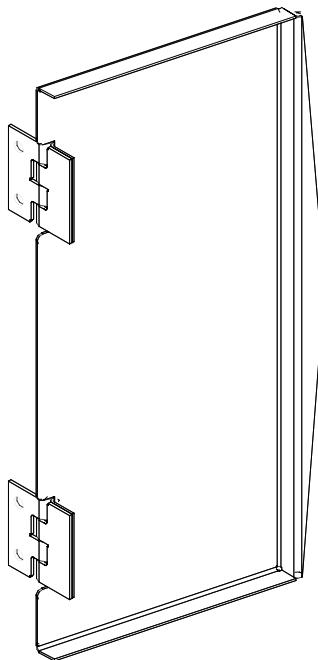

Scrap Basket Lid
 Weldment
 05700-002-56-55

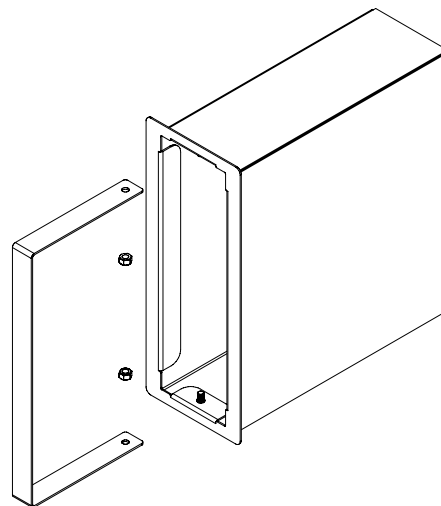

Scrap Basket Assembly
 06401-011-87-78

SECTION 6: PARTS SECTION
VENT COWL ASSEMBLY/VENT SCOOP OPTION

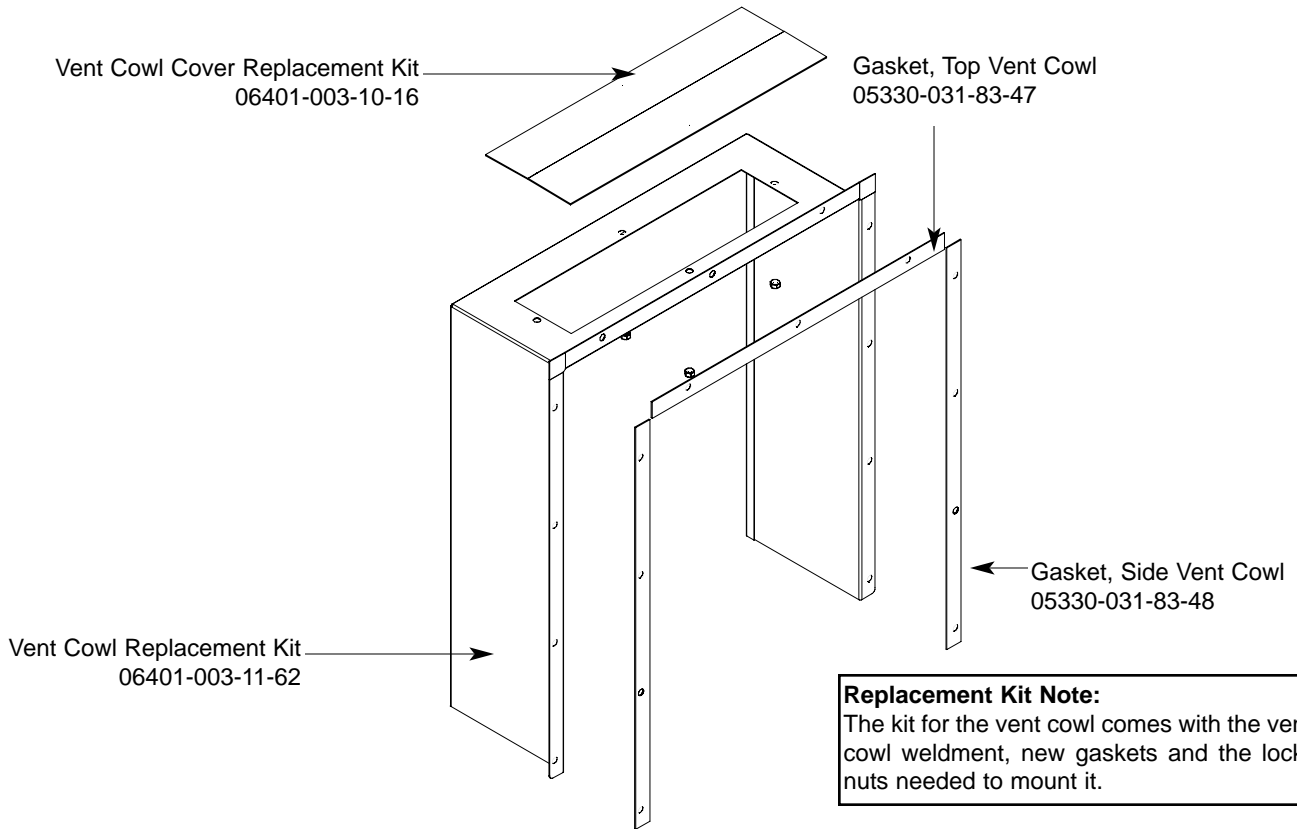

VENT SCOOP OPTION

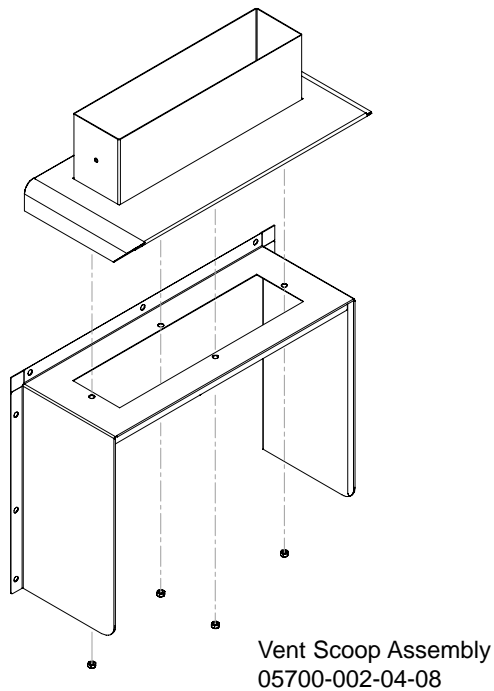

SECTION 6: PARTS SECTION

EXHAUST FAN CONTROL/TABLE LIMIT SWITCH OPTIONS

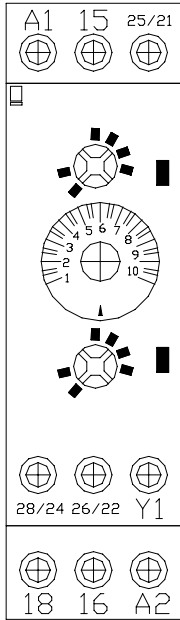

Delay Timer
05945-011-65-44

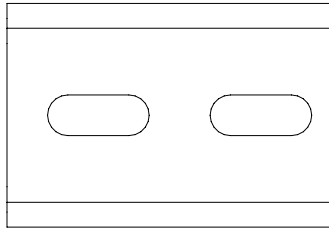

2" Din Rail
05700-002-36-09

**FAN LOAD ON TIMER OUTPUT
5A, 1/4HP, 240 V AC MAX**

Decal, Fan Load
09905-003-32-20

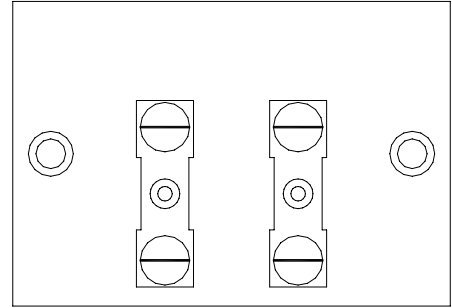

Terminal Board
05940-011-84-41

Kit, Exhaust Fan - Electric & Steam Models
05700-031-90-53

Kit, Exhaust Fan - Gas Models
05700-003-14-59

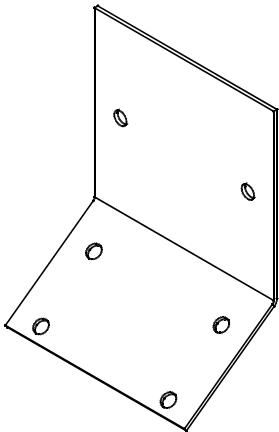

Whisker Limit Switch
Mounting Bracket
05700-000-14-55

Whisker Switch Assembly
05700-002-23-94

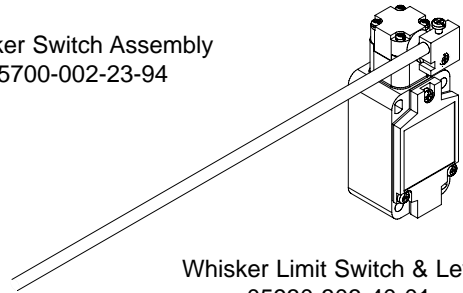

Whisker Limit Switch & Lever
05930-303-40-01

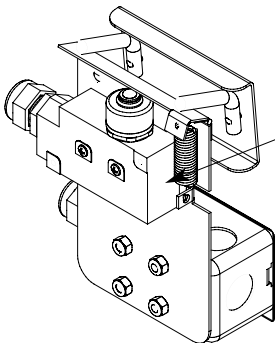

Limit Switch
05930-002-62-81

Striker Plate Limit Switch
Assembly
05700-002-62-94

Proximity Limit
Switch Sensor
06685-002-94-15

Bracket, Proximity Switch
05700-002-94-93

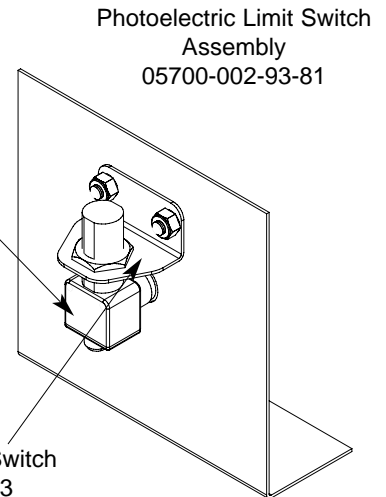

Photoelectric Limit Switch
Assembly
05700-002-93-81

SECTION 6: PARTS SECTION

SIDE LOADER TRACK ASSEMBLY/LEG REPLACEMENTS/STRAINER

**Side loader track assembly
(left to right model shown).**

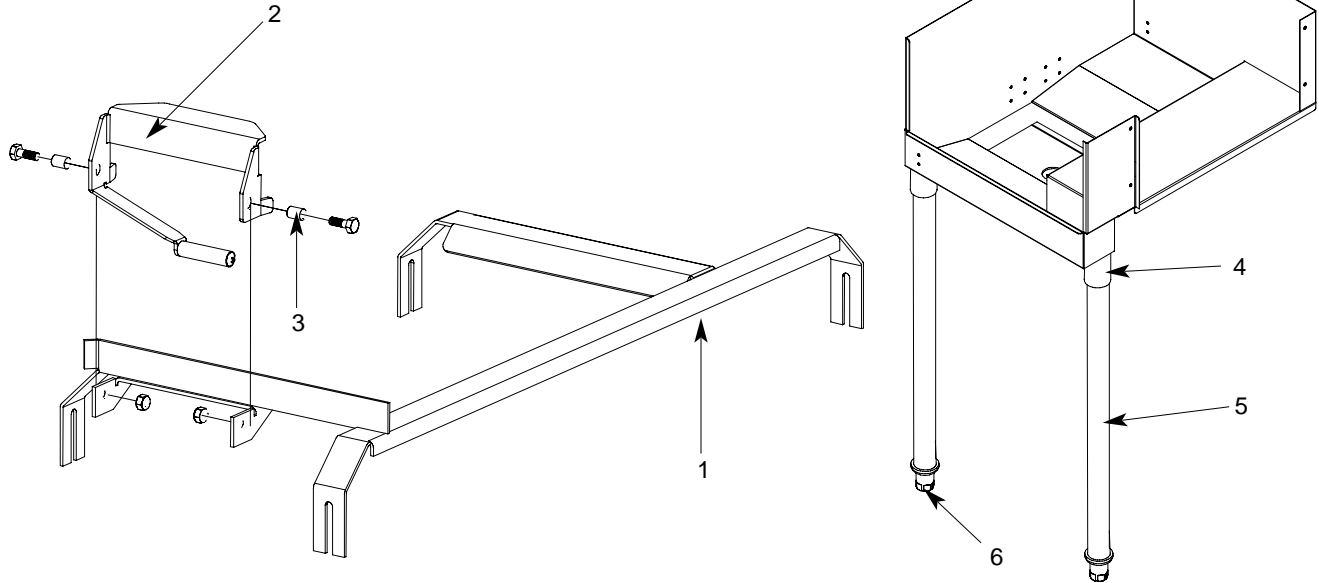

ITEM	QTY	DESCRIPTION	Mfg. No.
1	1	Track Weldment (Left to Right) 24"	05700-031-78-98
	1	Track Weldment (Right to Left) 24"	05700-031-95-20
	1	Track Weldment (Left to Right) 30"	05700-003-04-57
	1	Track Weldment (Right to Left) 30"	05700-003-04-58
2	1	Actuator Switch Replacement Kit	06401-003-10-64
3	2	Spacer	05700-011-71-44
4	1	Leg Socket Replacement Kit	06401-003-09-79
5	1	Leg Support Replacement Kit	06401-003-09-80
6	1	Bullet Foot	05340-108-01-03

Replacement Kits Notes:

The actuator switch replacement kit comes with the actuator weldment, mounting hardware and (2) spacers.

The leg socket replacement kit has the leg socket, mounting hardware and set screw.

The leg support replacement kit has the leg and the bullet foot included.

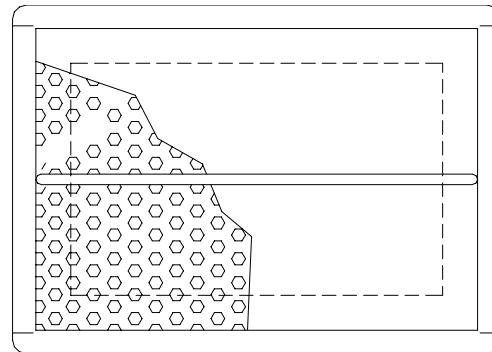

**Front Strainer Weldment
05700-021-85-10**

SECTION 6: PARTS SECTION

SIDE LOADER PAWL BAR ASSEMBLIES/PAWL BAR BRACKET/MAGNET

Replacement Kit Note:
The kits for the pawl bars come with the bar weldment, (3) dogs and the hardware.

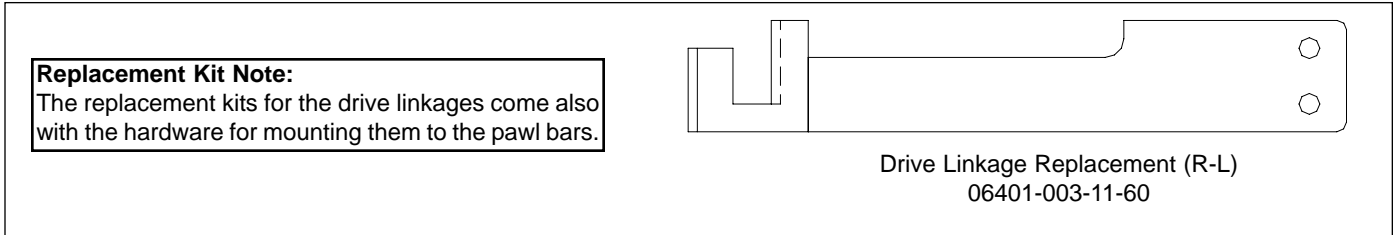
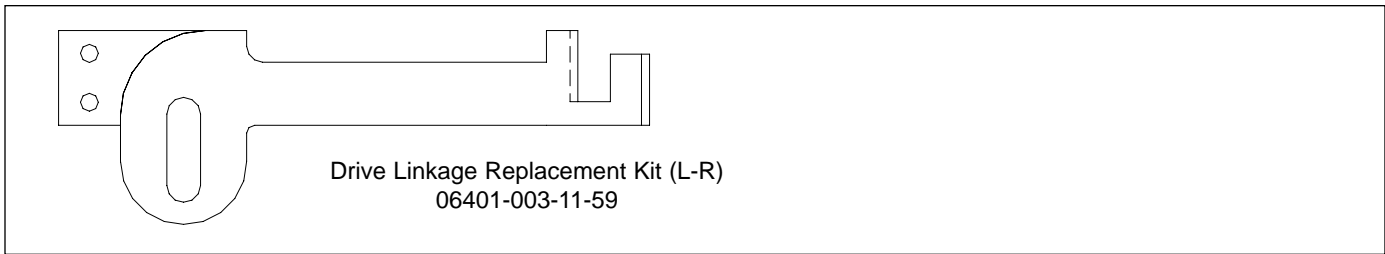
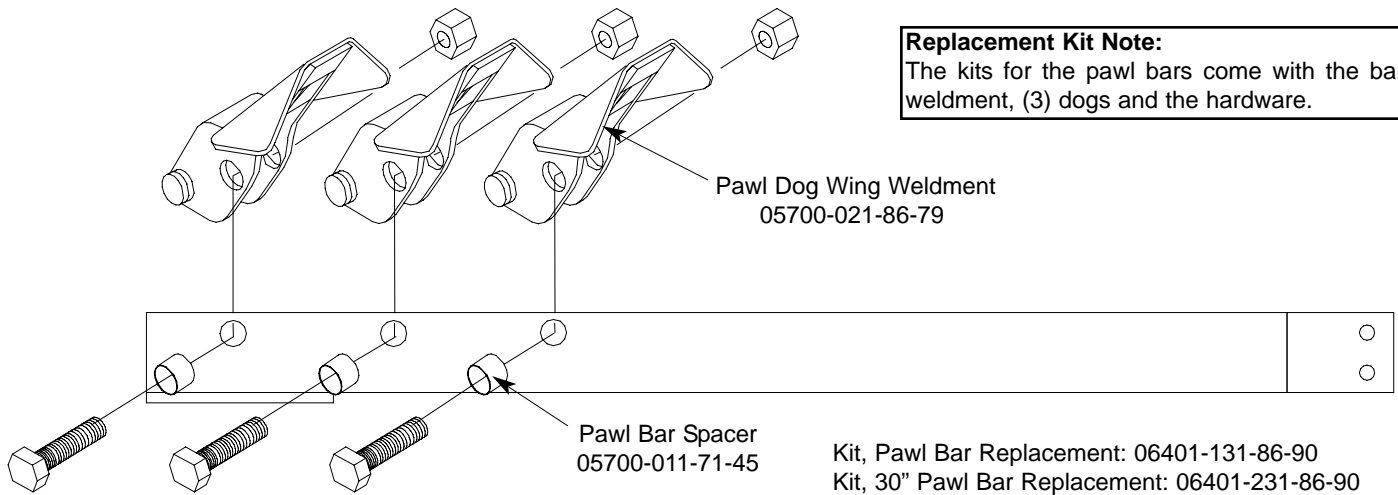

Replacement Kit Note:
The replacement kits for the drive linkages come also with the hardware for mounting them to the pawl bars.

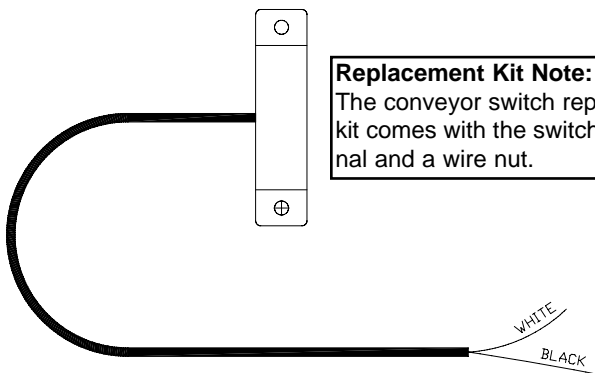

Service Note:
The cord for the conveyor switch needs to be cut to length in the field and have the pink terminal applied there.

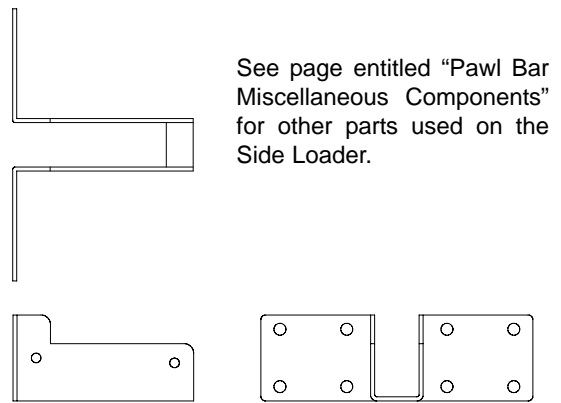

Pawl Bar Roller Bracket
05700-031-77-94

SECTION 6: PARTS SECTION
SIDE LOADER VENT COWL OPTION

Vent Cowl Replacement Kit (Left to Right)
 06401-003-11-81

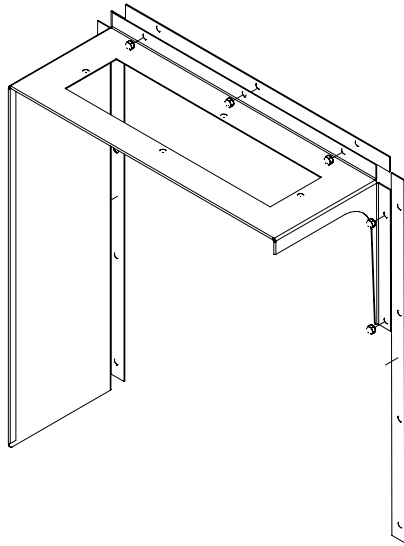

Vent Cowl Replacement Kit (Right to Left)
 06401-003-11-83

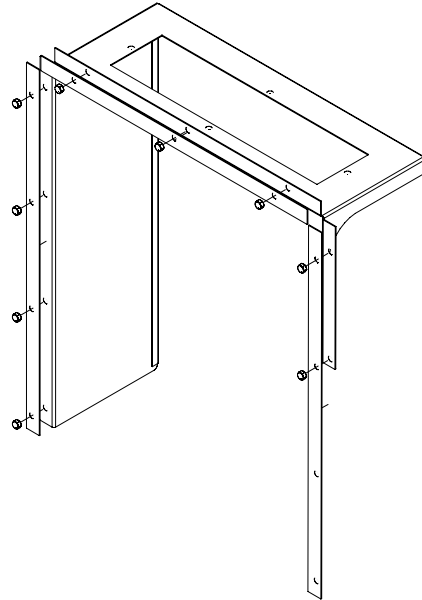

Service Note:
 One of the side gaskets that come in the kit will need to be cut to length in order to fit properly on the unit when replaced.

Replacement Kit Note:
 The replacement kit(s) for the vent cowls come with the cowls, the gaskets and mounting hardware.

Vent Cowl Gasket, Top: 05330-031-83-47
 Vent Cowl Gasket, Side: 05330-031-83-48

VENT SCOOP OPTION
 Vent Scoop Assembly
 05700-002-04-08

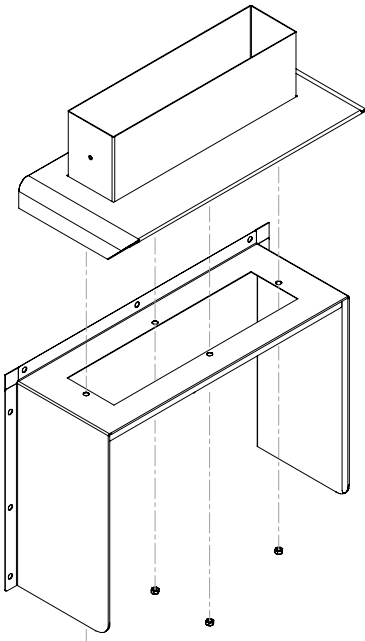

STANDARD ASSEMBLY
 Vent Cowl Cover Replacement Kit
 06401-003-10-16

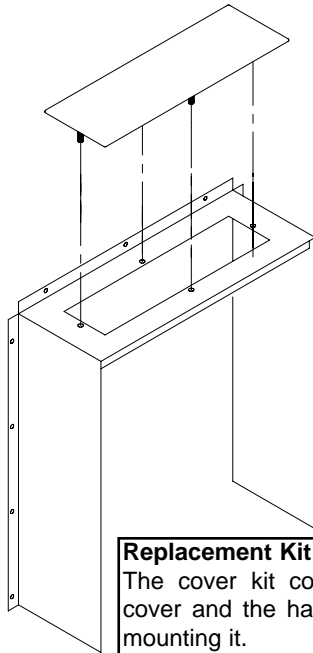

Replacement Kit Note:
 The cover kit contains the cover and the hardware for mounting it.

Vent Cowl Assembly for Hooded Side Loader Option
 05700-003-15-66

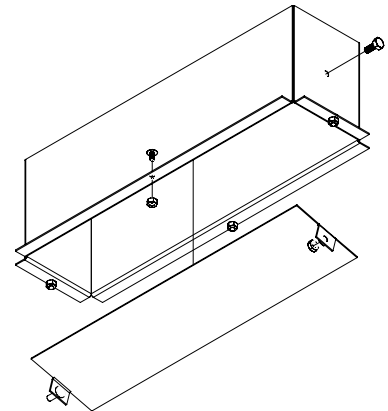

SECTION 6: PARTS SECTION
D226 STEAM BOOSTER CONTROL BOX ASSEMBLY

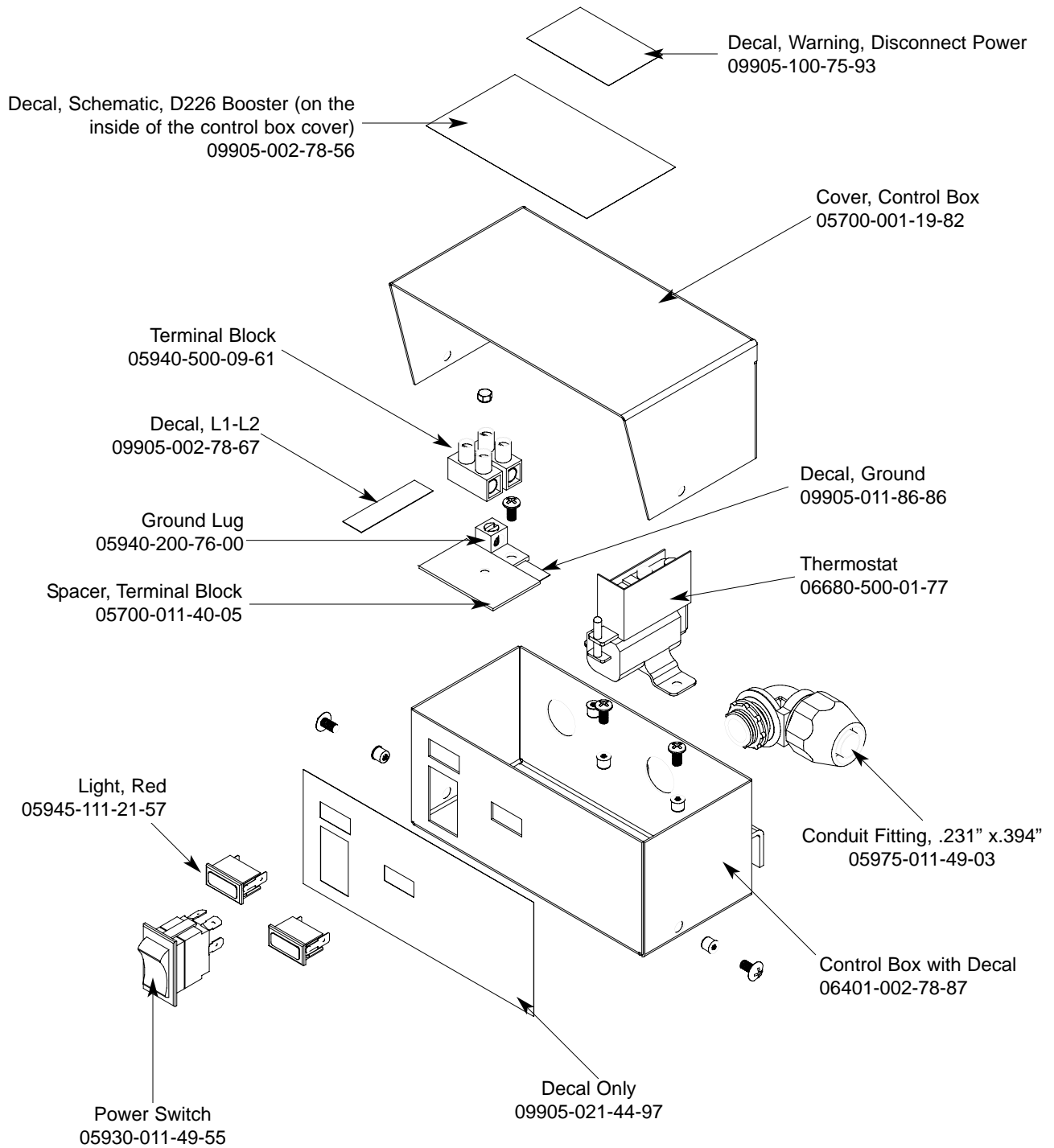

SECTION 6: PARTS SECTION
D226 STEAM BOOSTER PLUMBING ASSEMBLY

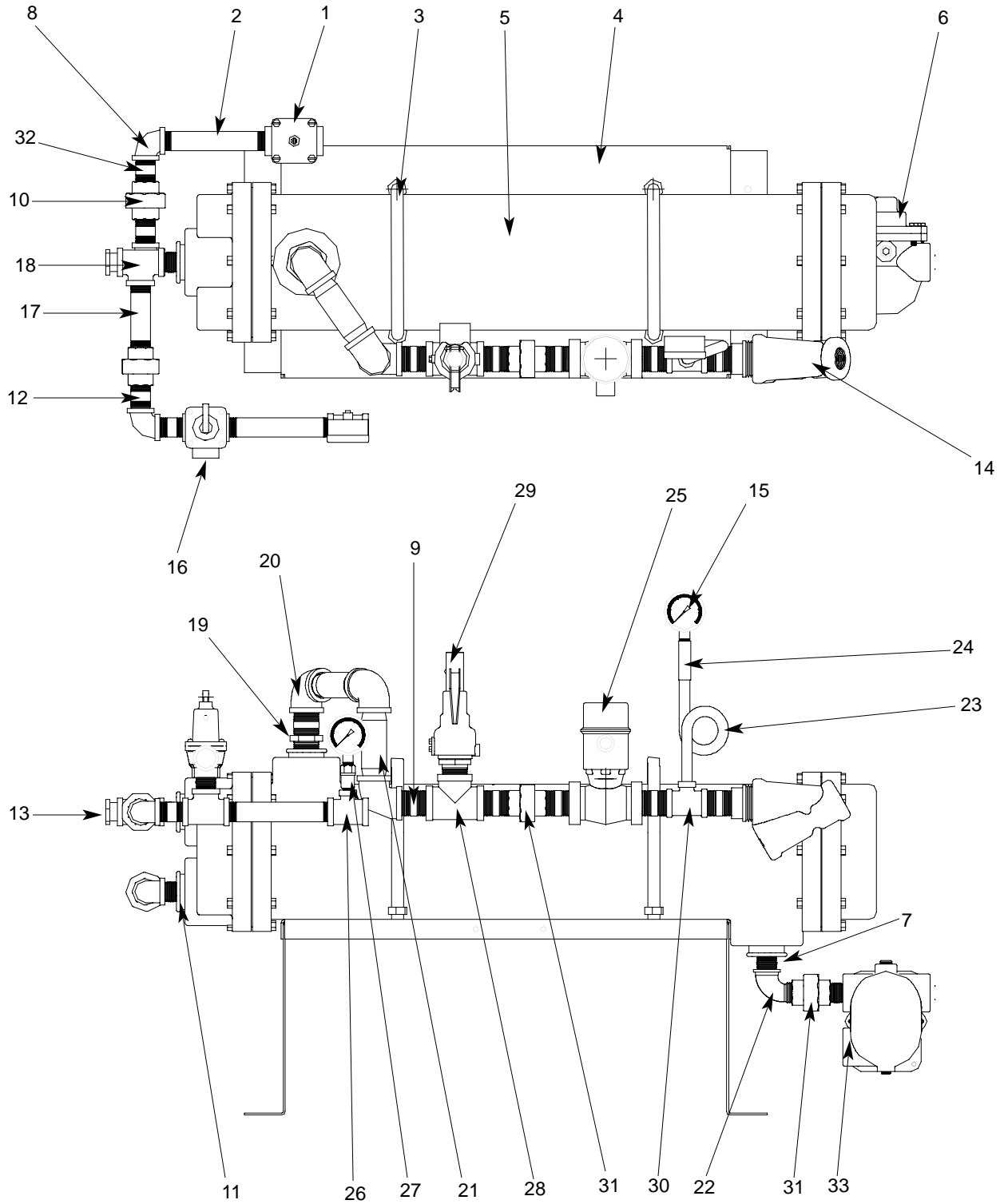

SECTION 6: PARTS SECTION**D226 STEAM BOOSTER PLUMBING ASSEMBLY (CONTINUED)**

ITEM	QTY	DESCRIPTION	Mfg. No.
1	1	Water Pressure Regulator, 3/4"	04820-100-01-06
2	2	Nipple, Brass, 3/4" NPT x 6" Long	05700-001-26-74
3	2	U-Bolt, 6", 5/8"-11 Thread	5306-458-01-04
4	1	Platform Weldment	05700-002-78-02
5	1	Heat Exchanger	4420-100-01-05
6	1	Steam Trap, 3/4"	06680-500-02-77
7	1	Bushing, 2" NPT x 3/4" NPT, Black Iron	04730-902-06-34
8	2	Elbow, 3/4" NPT, Brass	04730-206-13-00
9	6	Nipple, 1" NPT, Close, Black Iron	04730-907-08-34
10	2	Union, 3/4" NPT, Brass	04730-212-05-00
11	2	Bushing, 2" NPT x 3/4" NPT, Brass	04730-202-18-00
12	4	Nipple, 3/4" NPT x 1-3/8" Long	04730-207-34-00
13	1	Bushing, Hex 3/4" M x 1/2" F, Brass	04730-002-56-27
14	1	Y-Strainer, 1" NPT, Black Iron	04730-217-02-32
15	2	Pressure Gauge	06685-111-88-34
16	1	Steam Relief Valve	04820-100-07-06
17	2	Nipple, 3/4" NPT x 4" Long, Brass	04730-207-05-00
18	2	Tee, 3/4" NPT x 3/4" NPT x 3/4" NPT, Brass	04730-211-01-34
19	1	Bushing, 2" NPT x 1" NPT, Black Iron	04730-002-94-51
20	3	Elbow, 90°, 1" NPT, Black Iron	04730-906-03-34
21	2	Nipple, 1" NPT x 4" Long, Black Iron	04730-907-09-34
22	1	Elbow, 90°, Street, 3/4" NPT, Black Iron	04730-011-87-37
23	1	Nipple, Pigtail, 1/4" NPT	04730-907-14-34
24	1	Coupling, 1/4" NPT x 1/4" NPT	04730-904-01-34
25	1	Steam Solenoid Valve, 240VA	04820-100-29-34
25	1	Steam Solenoid Valve, 200VA	04820-002-93-66
25	1	Steam Solenoid Valve (ASCO)	04820-002-90-26
26	1	Tee, 3/4" NPT x 3/4" NPT x 1/4" NPT, Brass	04730-211-04-00
27	1	Valve, Test Cock, 1/4" NPT	04810-011-72-67
28	1	Tee, 1" NPT x 1" NPT x 1" NPT, Black Iron	04730-911-01-34
29	1	Valve, Safety Relief 1" NPT	04820-100-01-35
30	1	Tee, 1" NPT x 1" NPT x 1/4" NPT, Black Iron	04730-911-01-00
31	2	Union, 3/4" NPT, Black Iron	04730-912-01-00
32	2	Nipple, 3/4" NPT x 2" Long, Brass	04730-207-46-00
33	2	Nipple, 3/4" NPT, Close, Black Iron	04730-907-01-00

SECTION 6: PARTS SECTION

GO*BOX COMPONENTS

A GO*BOX is a kit of the most needed parts for a particular model or model family to successfully effect a repair in the first call 90% or more of the time.

The following components may be ordered together using part number 06401-002-14-98.

QTY	DESCRIPTION	Mfg. No.
1	Drive Motor Contactor	05945-111-68-38
1	Contactora, Wash Heater, 3 ph, 3 pole	05945-002-24-70
1	Contactora, Wash Heater, 1 ph, 4 pole	05945-111-68-37
2	Final Rinse Arm End Cap	05700-011-35-92
1	Float Switch, Dual, Wash & Prewash	06680-121-70-71
1	Gasket, Pawl Bar Gutter	05330-011-68-55
1	Gauge, Pressure	06685-111-88-34
6	Glide, Door Edge	05700-111-70-92
2	Magnet, Door Reed Switch	05930-111-51-68
2	O Ring, Prewash Manifold	05330-400-12-08
2	O Ring, Wash Manifold	05330-011-74-56
1	Overload, Drive Motor	05945-111-68-39
1	Overload, Wash Motor	05945-111-68-40
1	Relay,120v, 3 PDT	05945-111-72-51
1	Relay,120v,50/60Hz 3A Control	05945-111-35-19
1	Repair Kit, 3/4" Vacuum Breaker	04820-001-60-57
4	Roller, Pawl Bar	05700-011-68-16
1	Seal Kit for Wash and Prewash pump	05330-011-71-98
2	Solenoid Valve, Fill & Rinse	04810-100-53-00
2	Switch, Power	05930-011-49-55
2	Switch, Reed, Actuator (NC)	05930-111-68-44
1	Switch, Reed, Door (NO)	05930-111-68-86
1	Thermometer, 48" Capillary	06685-111-68-48
1	Thermometer, 96" Capillary	06685-111-68-49
2	Thermostat, Wash High Limit	05930-121-71-36
2	Thermostat, Wash Regulating	05930-121-67-72
1	Transformer,150VA	05950-011-68-35
1	Valve, Ball 1 1/2" NPT	04820-111-71-46

SECTION 6: PARTS SECTION

RINSE FILL OPTION

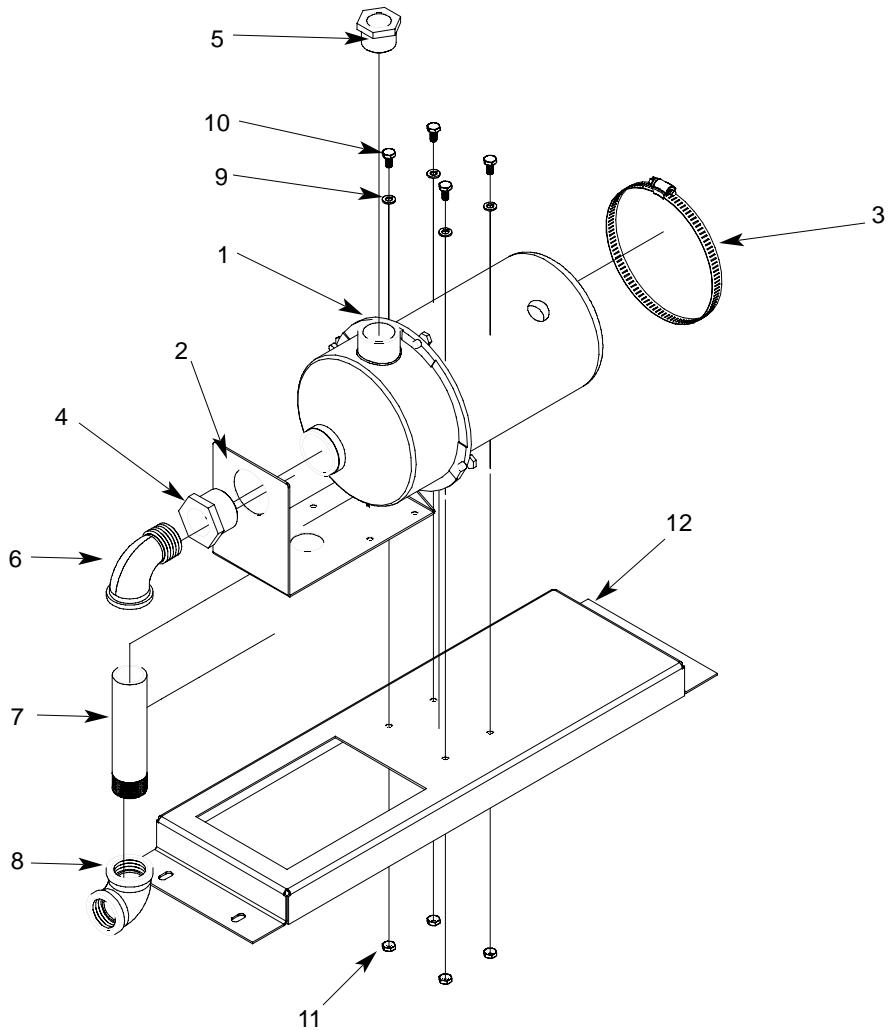

ITEM	QTY	DESCRIPTION	Mfg. No.
	1	Rinse Fill Motor Assembly	05700-002-40-25
1	1	Motor	06105-002-72-71
2	1	Bracket, Pump Mounting	05700-002-63-59
3	1	Clamp, Hose 5 5/8" to 6"	04730-011-34-90
4	1	Reducer Bushing, 1 1/4" to 1"	04730-002-73-62
5	1	Reducer Bushing 1" to 3/4"	04730-011-65-14
6	1	Elbow, 90 Deg., 1" Street	04730-002-11-99
7	1	Nipple, 1" NPT x 6" Long Brass	04730-002-12-00
8	1	Elbow, 90 Deg. Brass Female	04730-002-12-55
9	4	Lockwasher, 1/4"	05311-274-01-00
10	4	Bolt, 1/4"-20 x 1/2" Long	05305-274-02-00
11	4	Nut, Hex S/S 1/4"-20	05310-274-01-00
12	1	Rinse Motor Mounting Bracket	05700-002-38-90

SECTION 7: ELECTRICAL SCHEMATICS

SECTION 7: ELECTRICAL SCHEMATICS

AJ-54CE (208-230 VOLT, 60 HZ, SINGLE PHASE)

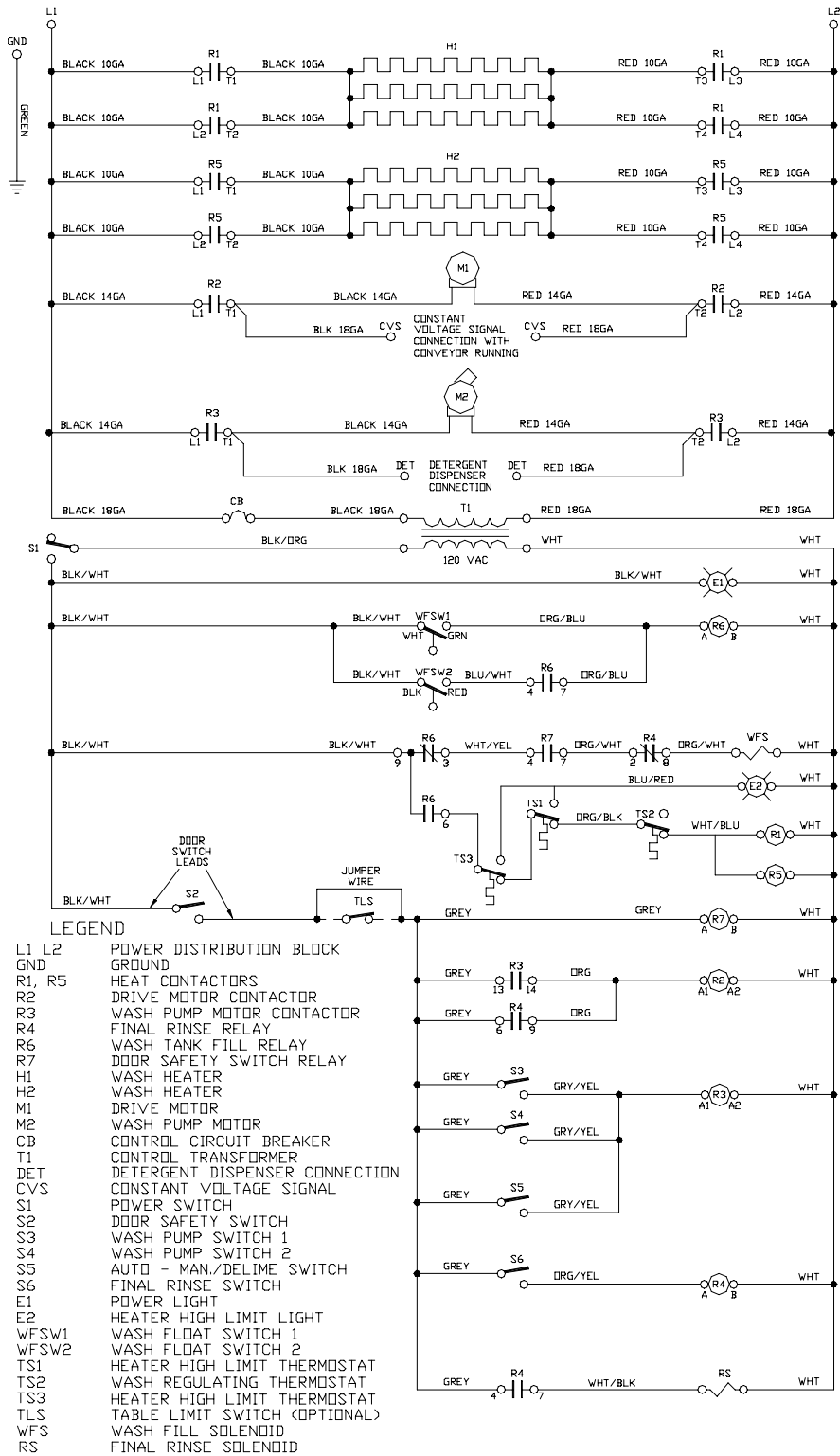

09905-002-12-70

SECTION 7: ELECTRICAL SCHEMATICS

AJ-54CE (208-230 VOLT, 60 HZ, THREE PHASE)

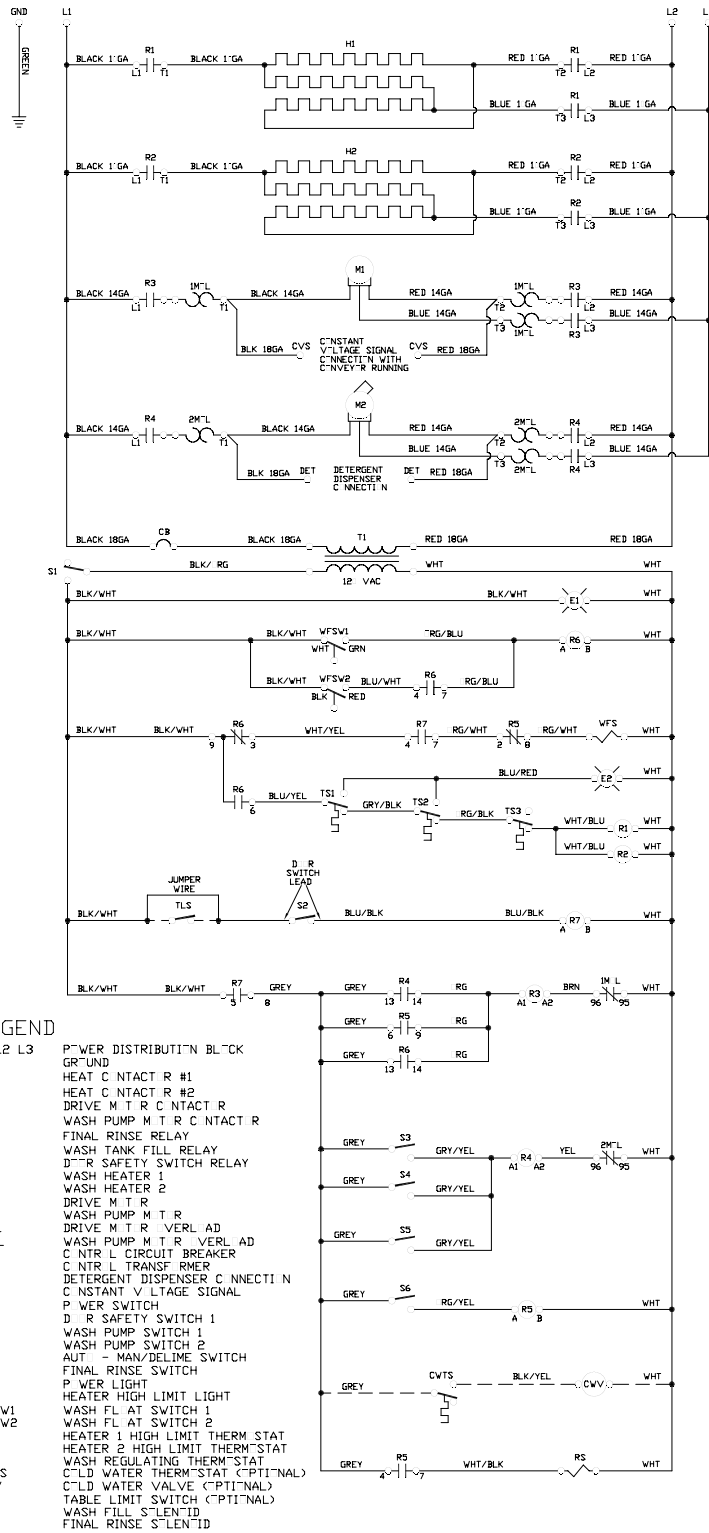

99'5-'31-91-7'

SECTION 7: ELECTRICAL SCHEMATICS

AJ-54CE (460-575-600 VOLT, 60 HZ, THREE PHASE)

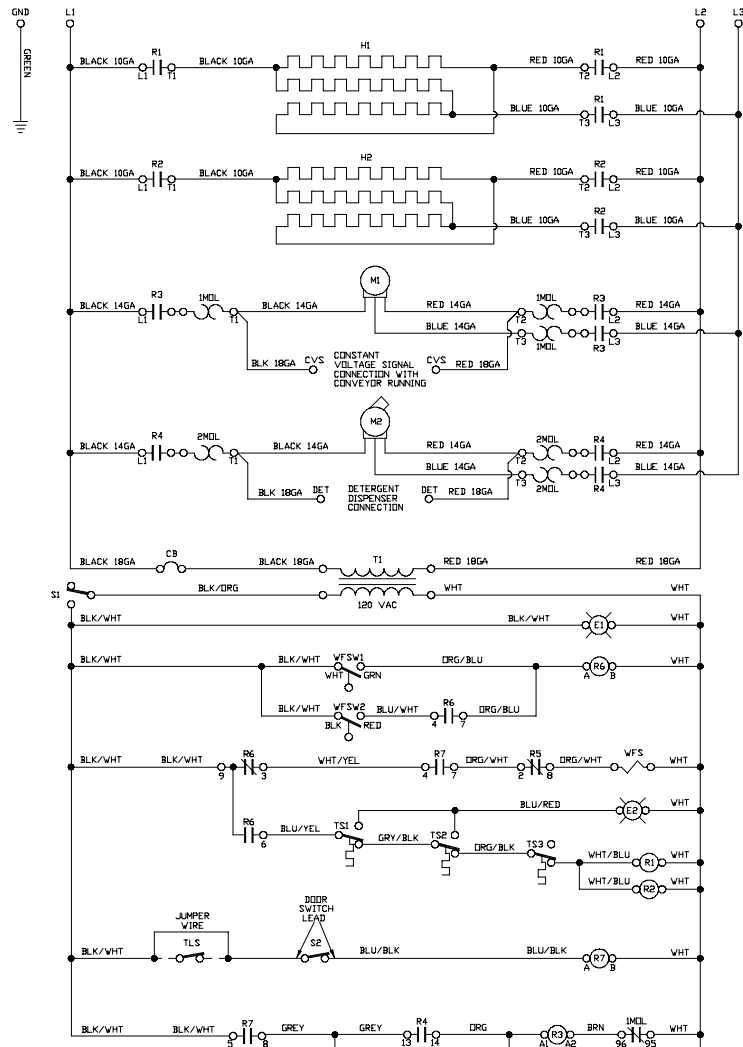

LEGEND

- | | |
|----------|----------------------------------|
| L1 L2 L3 | POWER DISTRIBUTION BLOCK |
| GND | GROUND |
| R1 | HEAT CONTACTOR #1 |
| R2 | HEAT CONTACTOR #2 |
| R3 | DRIVE MOTOR CONTACTOR |
| R4 | WASH PUMP MOTOR CONTACTOR |
| R5 | FINAL RINSE RELAY |
| R6 | WASH TANK FILL RELAY |
| R7 | DDDR SAFETY SWITCH RELAY |
| H1 | WASH HEATER 1 |
| H2 | WASH HEATER 2 |
| M1 | DRIVE MOTOR |
| M2 | WASH PUMP MOTOR |
| 1MDL | DRIVE MOTOR OVERLOAD |
| 2MDL | WASH PUMP MOTOR OVERLOAD |
| CB | CONTROL CIRCUIT BREAKER |
| T1 | CONTROL TRANSFORMER |
| DET | DETERGENT DISPENSER CONNECTION |
| CVS | CONSTANT VOLTAGE SIGNAL |
| S1 | POWER SWITCH |
| S2 | DDDR SAFETY SWITCH 1 |
| S3 | WASH PUMP SWITCH 1 |
| S4 | WASH PUMP SWITCH 2 |
| S5 | AUTO - MAN/DELIME SWITCH |
| S6 | FINAL RINSE SWITCH |
| E1 | POWER LIGHT |
| E2 | HEATER HIGH LIMIT LIGHT |
| WFSW1 | WASH FLOAT SWITCH 1 |
| WFSW2 | WASH FLOAT SWITCH 2 |
| TS1 | HEATER 1 HIGH LIMIT THERMOSTAT |
| TS2 | HEATER 2 HIGH LIMIT THERMOSTAT |
| TS3 | WASH REGULATING THERMOSTAT |
| CWTS | COLD WATER THERMOSTAT (OPTIONAL) |
| CWV | COLD WATER VALVE (OPTIONAL) |
| TLS | TABLE LIMIT SWITCH (OPTIONAL) |
| WFS | WASH FILL SOLENOID |
| RS | FINAL RINSE SOLENOID |

SECTION 7: ELECTRICAL SCHEMATICS

AJ-54CS (208-230 VOLT, 60 HZ, SINGLE PHASE)

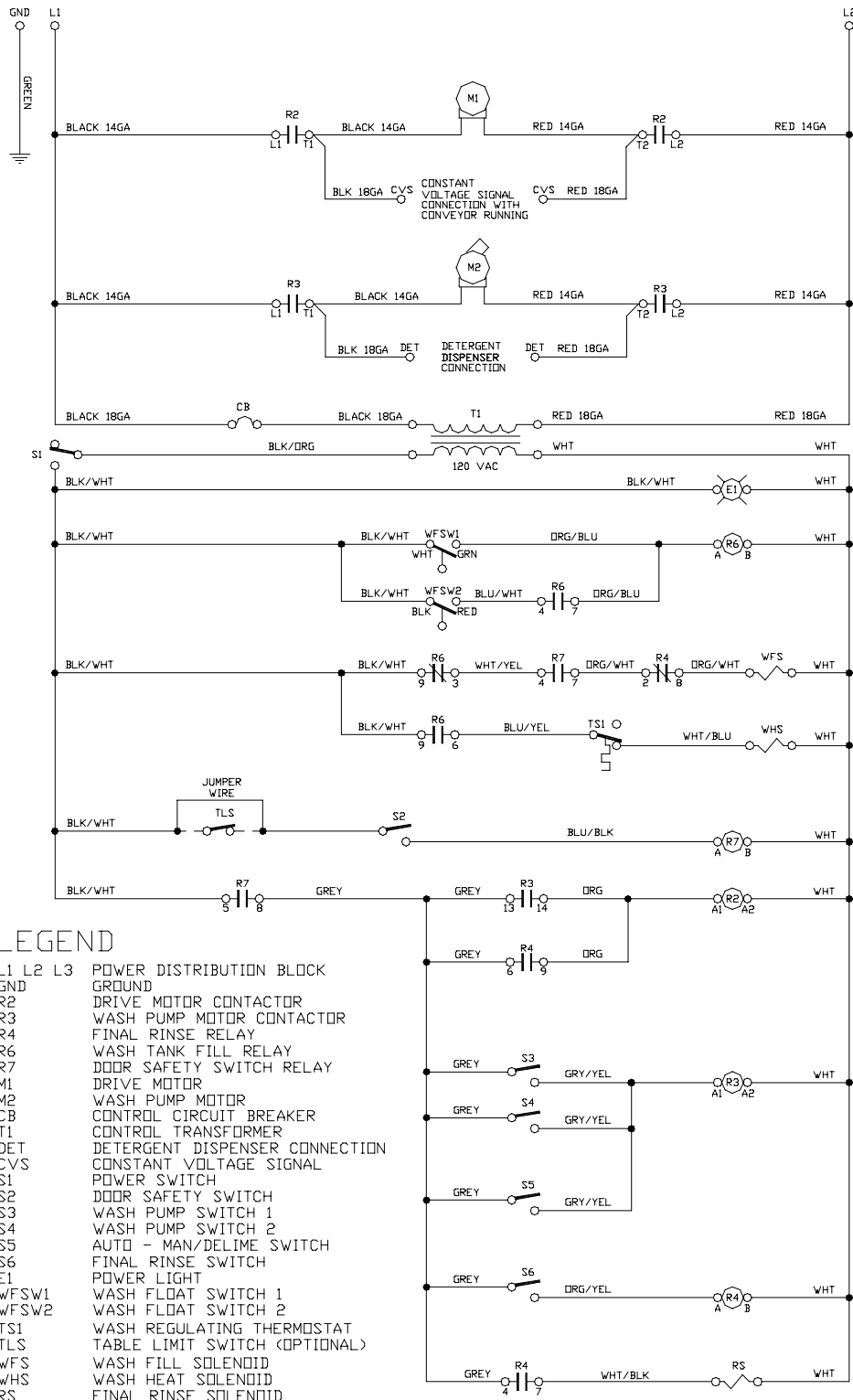

9905-031-80-23a

SECTION 7: ELECTRICAL SCHEMATICS

AJ-54CS (208-230 VOLT, 60 HZ, THREE PHASE)

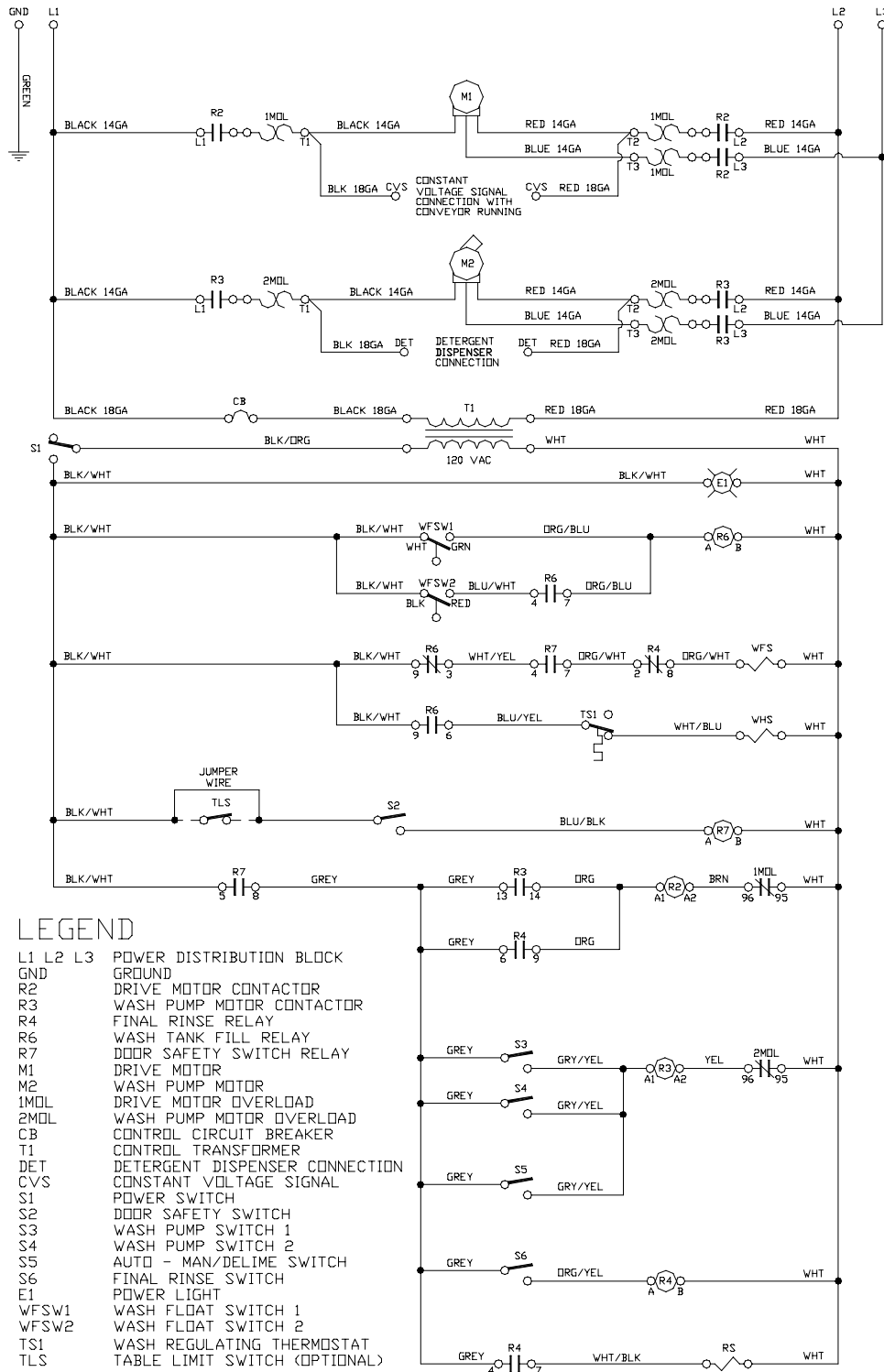

LEGEND

- L1 L2 L3 POWER DISTRIBUTION BLOCK
- GND GROUND
- R2 DRIVE MOTOR CONTACTOR
- R3 WASH PUMP MOTOR CONTACTOR
- R4 FINAL RINSE RELAY
- R6 WASH TANK FILL RELAY
- R7 DOOR SAFETY SWITCH RELAY
- M1 DRIVE MOTOR
- M2 WASH PUMP MOTOR
- 1MDL DRIVE MOTOR OVERLOAD
- 2MDL WASH PUMP MOTOR OVERLOAD
- CB CONTROL CIRCUIT BREAKER
- T1 CONTROL TRANSFORMER
- DET DETERGENT DISPENSER CONNECTION
- CVS CONSTANT VOLTAGE SIGNAL
- S1 POWER SWITCH
- S2 DOOR SAFETY SWITCH
- S3 WASH PUMP SWITCH 1
- S4 WASH PUMP SWITCH 2
- S5 AUTO - MAN/DELIME SWITCH
- S6 FINAL RINSE SWITCH
- E1 POWER LIGHT
- WFSW1 WASH FLOAT SWITCH 1
- WFSW2 WASH FLOAT SWITCH 2
- TS1 WASH REGULATING THERMOSTAT
- TLS TABLE LIMIT SWITCH (OPTIONAL)
- WFS WASH FILL SOLENOID
- WHS WASH HEAT SOLENOID
- RS FINAL RINSE SOLENOID

9905-031-80-24

SECTION 7: ELECTRICAL SCHEMATICS

AJ-54CS (460-575-600 VOLT, 60 HZ, THREE PHASE)

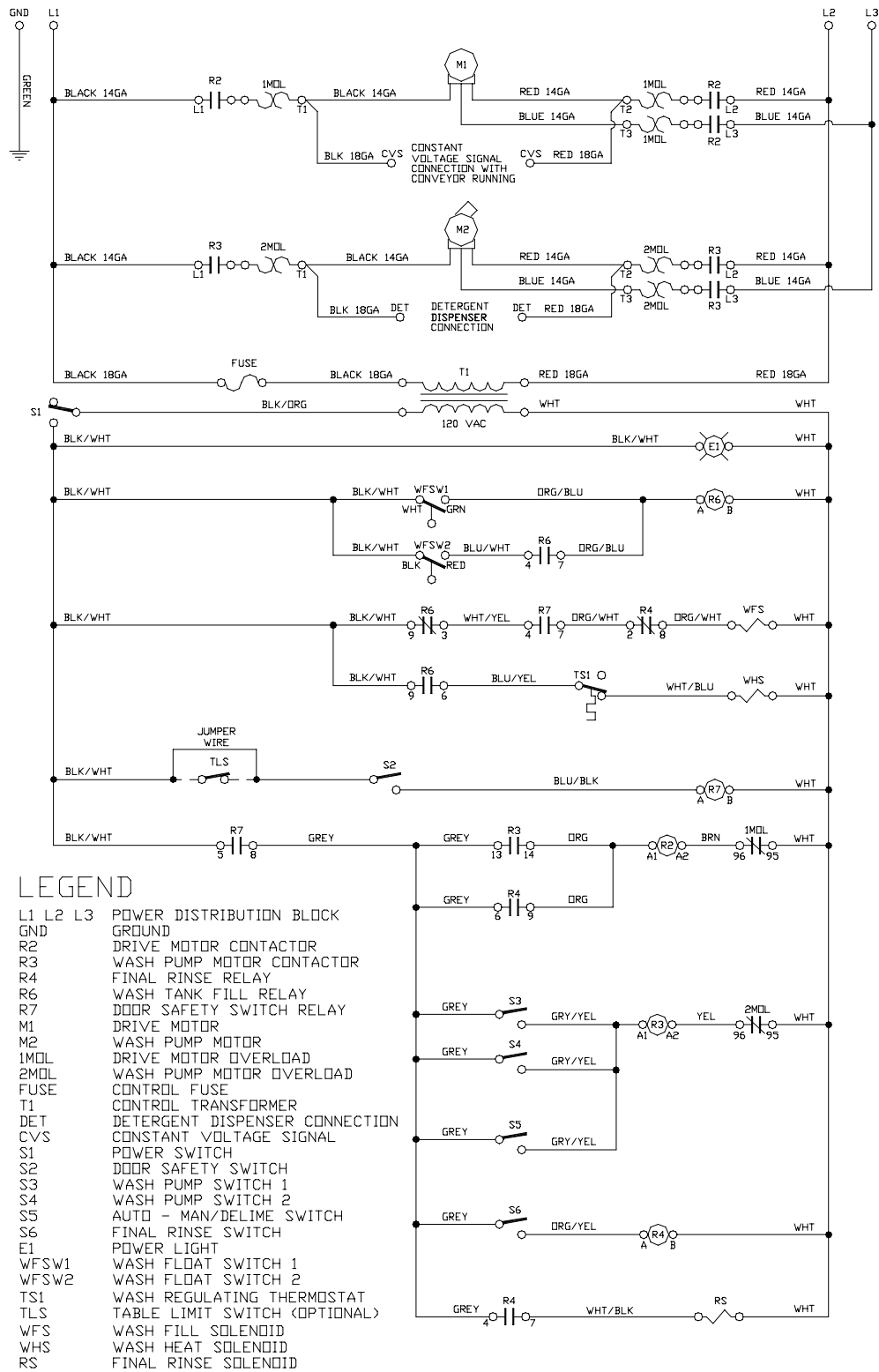

9905-031-80-26

SECTION 7: ELECTRICAL SCHEMATICS

AJ-76CE & AJ-90CE (208-230 VOLT, 60 HZ, SINGLE PHASE)

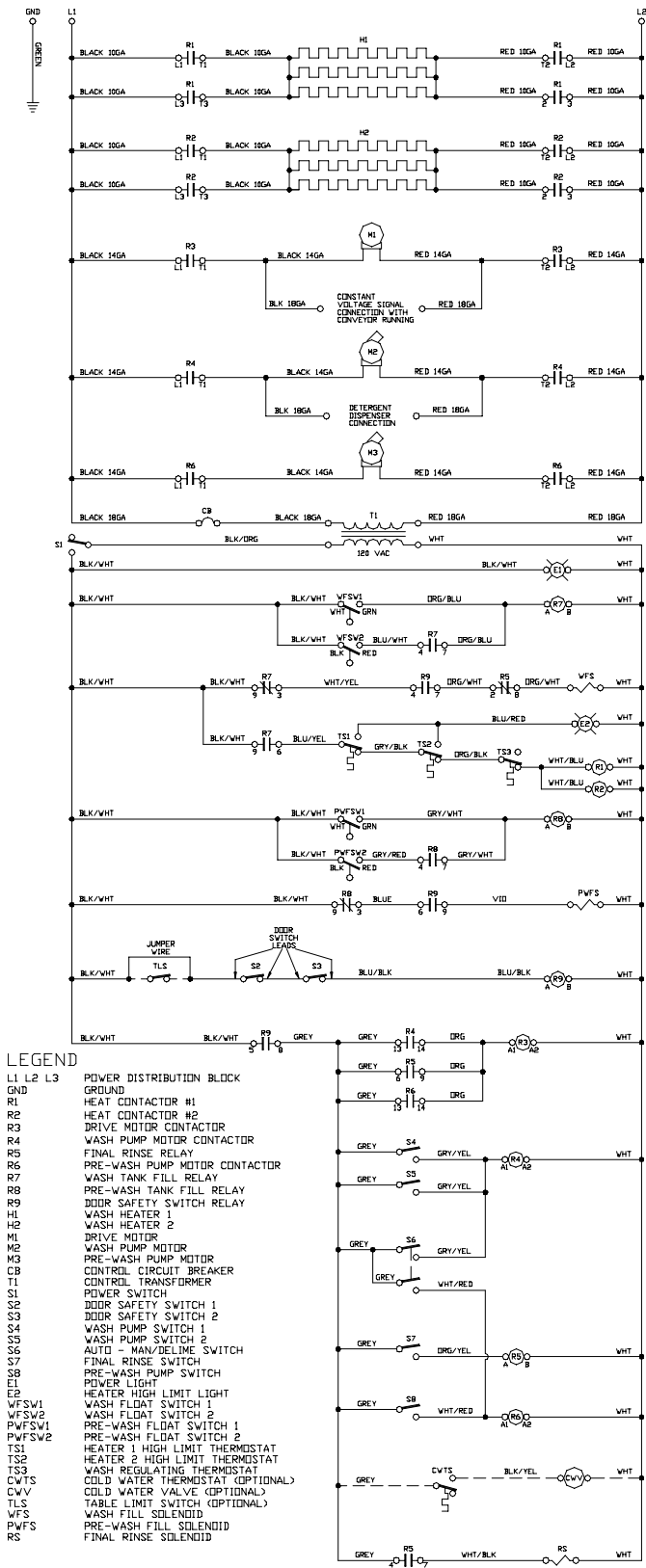

- LEGEND**
- L1 L2 L3 POWER DISTRIBUTION BLOCK
 - GND GROUND
 - R1 HEAT CONTACTOR #1
 - R2 HEAT CONTACTOR #2
 - R3 DRIVE MOTOR CONTACTOR
 - R4 WASH PUMP MOTOR CONTACTOR
 - R5 FINAL RINSE RELAY
 - R6 PRE-WASH PUMP MOTOR CONTACTOR
 - R7 WASH TANK FILL RELAY
 - R8 PRE-WASH TANK FILL RELAY
 - R9 DDDR SAFETY SWITCH RELAY
 - H1 WASH HEATER 1
 - H2 WASH HEATER 2
 - M1 DRIVE MOTOR
 - M2 WASH PUMP MOTOR
 - M3 PRE-WASH PUMP MOTOR
 - CB CONTROL CIRCUIT BREAKER
 - T1 CONTROL TRANSFORMER
 - S1 POWER SWITCH
 - S2 DDDR SAFETY SWITCH 1
 - S3 DDDR SAFETY SWITCH 2
 - S4 WASH PUMP SWITCH 1
 - S5 WASH PUMP SWITCH 2
 - S6 AUTO - MAN/DELIME SWITCH
 - S7 FINAL RINSE SWITCH
 - S8 PRE-WASH PMP SWITCH
 - E1 POWER LIGHT
 - E2 HEATER HIGH LIMIT LIGHT
 - WFSW1 WASH FLDAT SWITCH 1
 - WFSW2 WASH FLDAT SWITCH 2
 - PWFSW1 PRE-WASH FLDAT SWITCH 1
 - PWFSW2 PRE-WASH FLDAT SWITCH 2
 - TS1 HEATER 1 HIGH LIMIT THERMOSTAT
 - TS2 HEATER 2 HIGH LIMIT THERMOSTAT
 - TS3 WASH REGULATING THERMISTAT
 - CWTS COLD WATER THERMISTAT (OPTIONAL)
 - CWV COLD WATER VALVE (OPTIONAL)
 - TL5 TABLE LIMIT SWITCH (OPTIONAL)
 - VFS WASH FILL SOLENOID
 - PWFS PRE-WASH FILL SOLENOID
 - RS FINAL RINSE SOLENOID

09905-031-80-35

SECTION 7: ELECTRICAL SCHEMATICS

AJ-76CE & AJ-90CE (208-230 VOLT, 60 HZ, THREE PHASE)

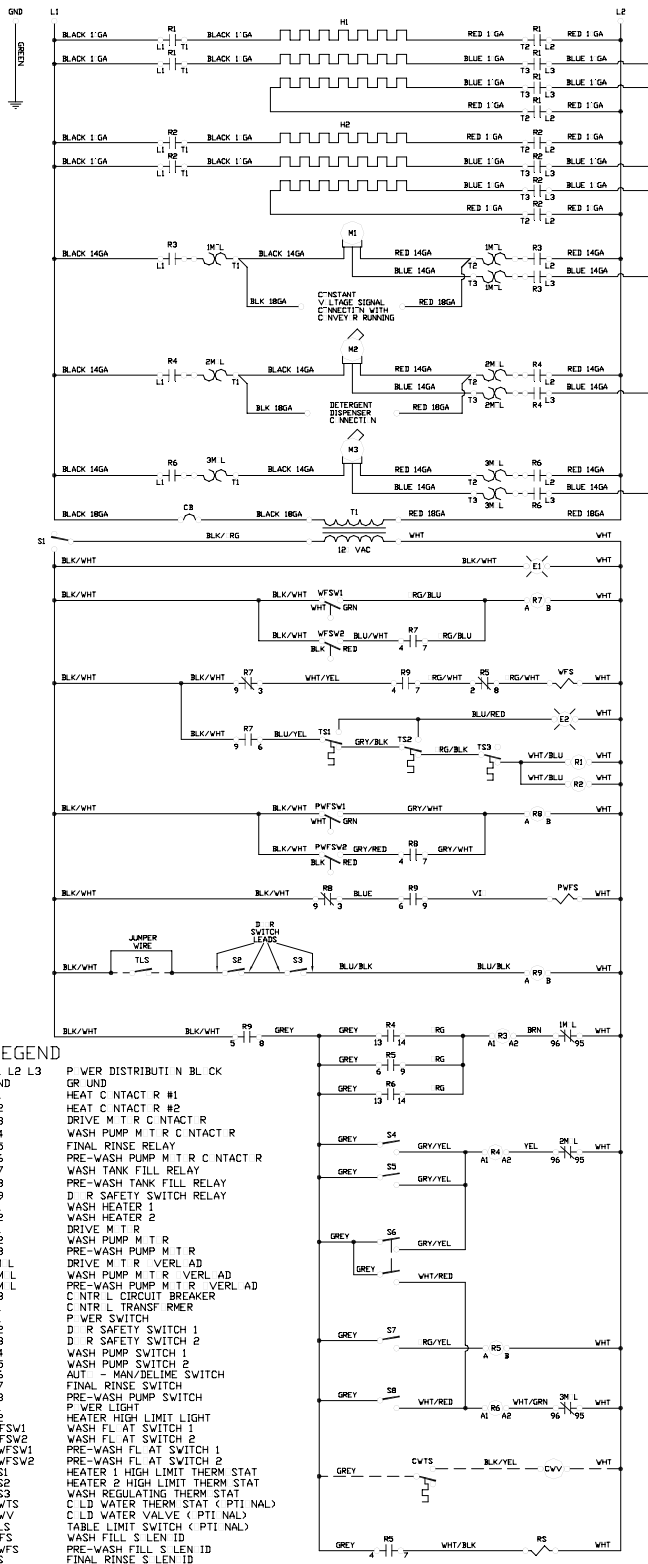

99-5-31-91-69

SECTION 7: ELECTRICAL SCHEMATICS

AJ-76CE & AJ-90CE (460-575-600 VOLT, 60 HZ, THREE PHASE)

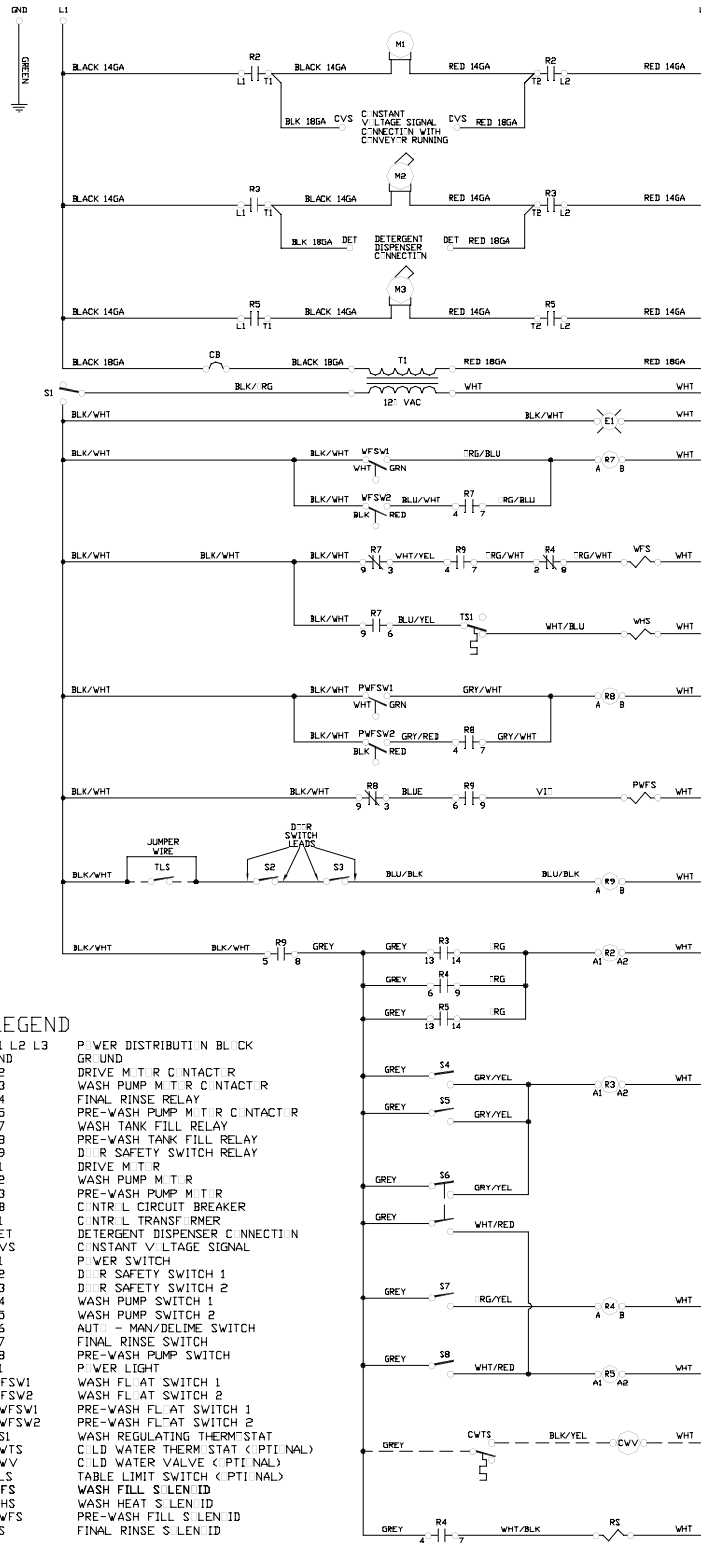

99-5-31-8-35

SECTION 7: ELECTRICAL SCHEMATICS

AJ-76CS & AJ-90CS (208-230 VOLT, 60 HZ, SINGLE PHASE)

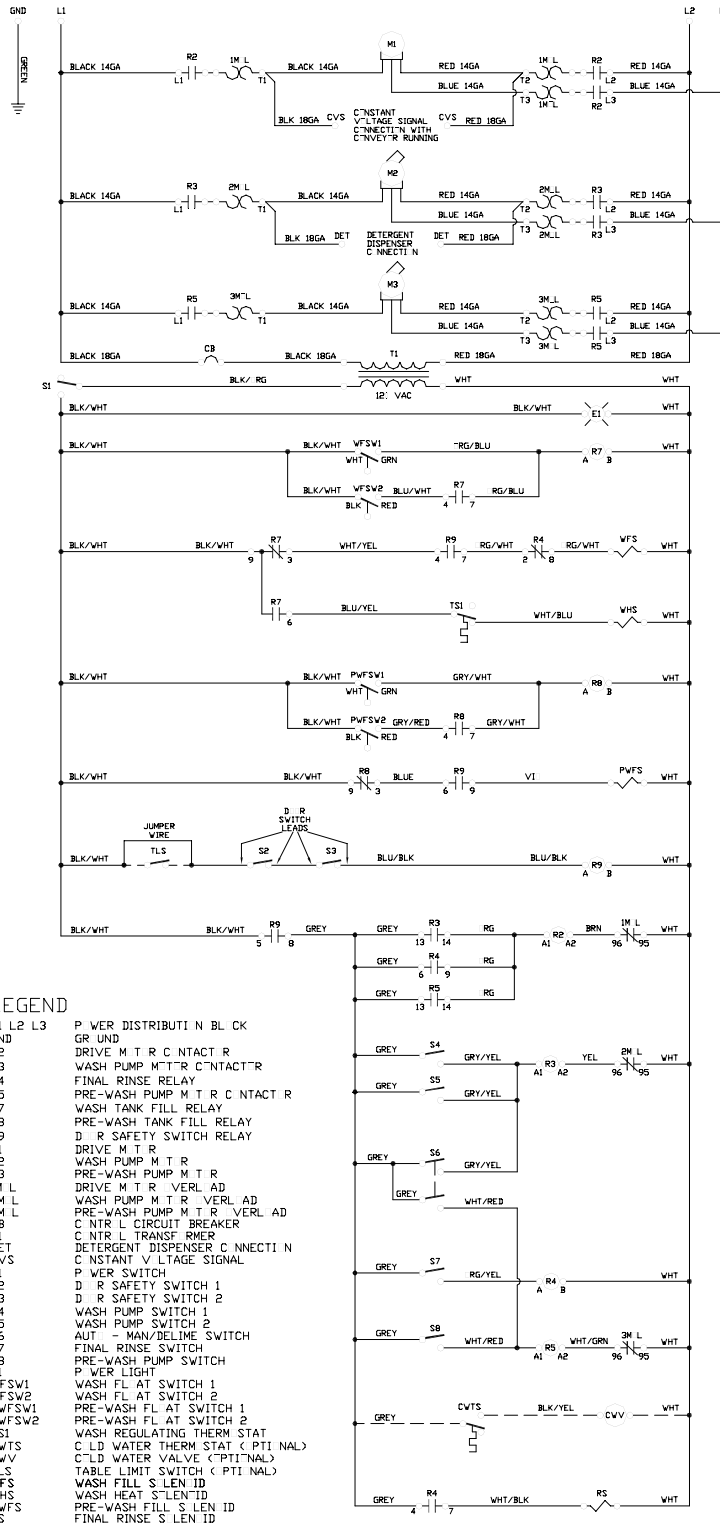

99 5- 31-8 -36

SECTION 7: ELECTRICAL SCHEMATICS

AJ-76CS & AJ-90CS (208-230 VOLT, 60 HZ, THREE PHASE)

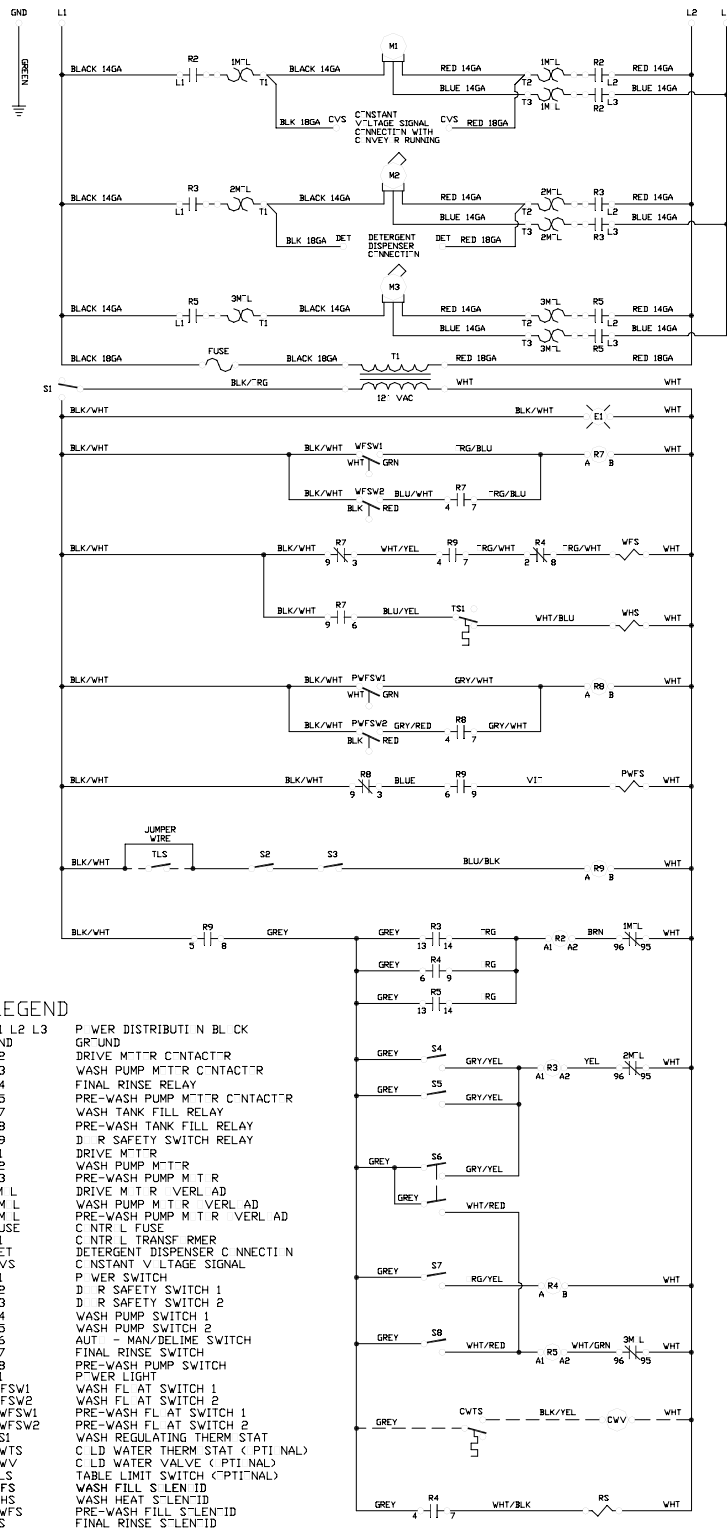

09905-002-46-98

SECTION 7: ELECTRICAL SCHEMATICS

AJ-76CS & AJ-90CS (460-575-600 VOLT, 60 HZ, THREE PHASE)

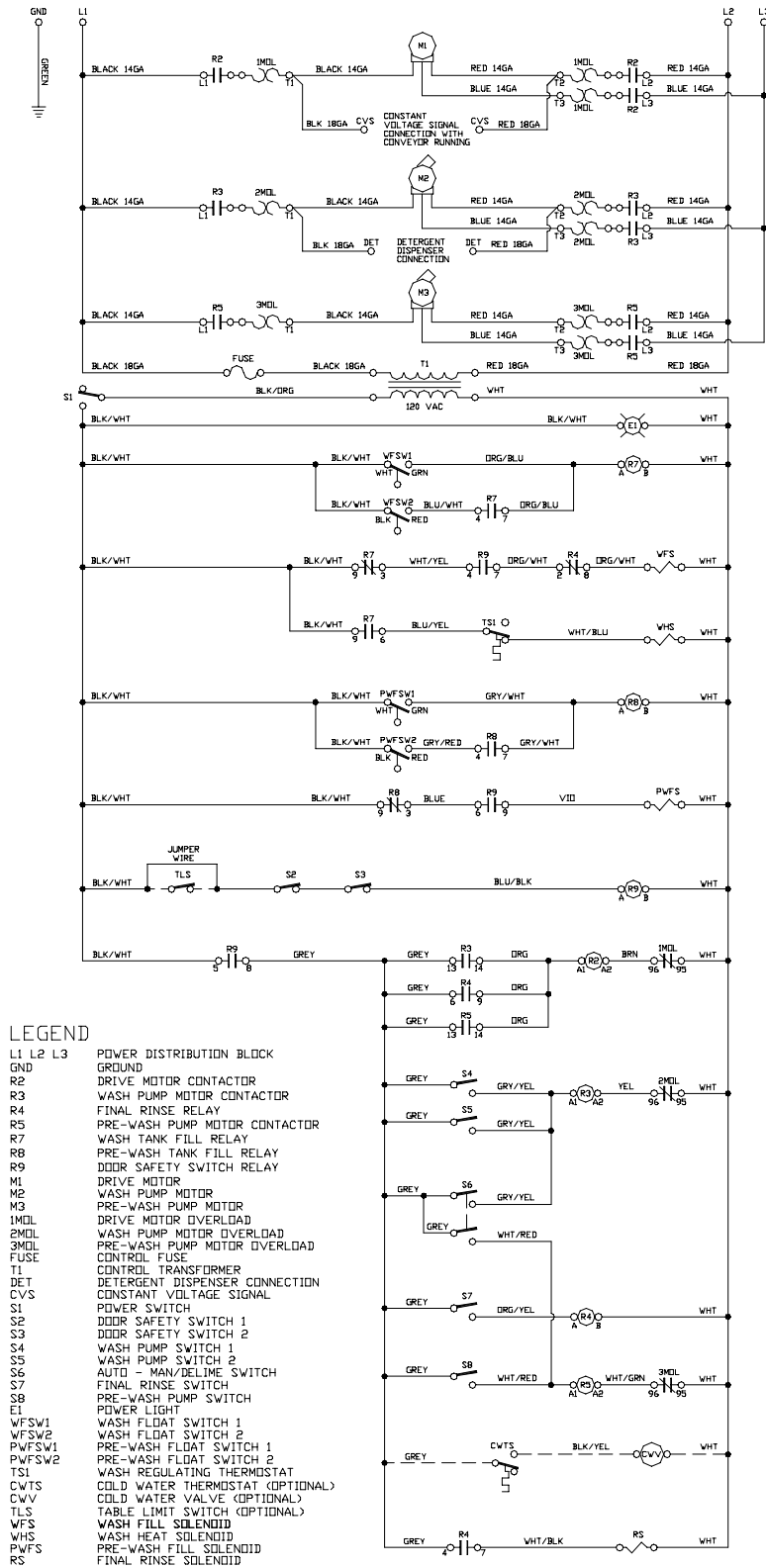

SECTION 7: ELECTRICAL SCHEMATICS

AJ-54CGP (208-230 VOLT, 60 HZ, SINGLE PHASE)

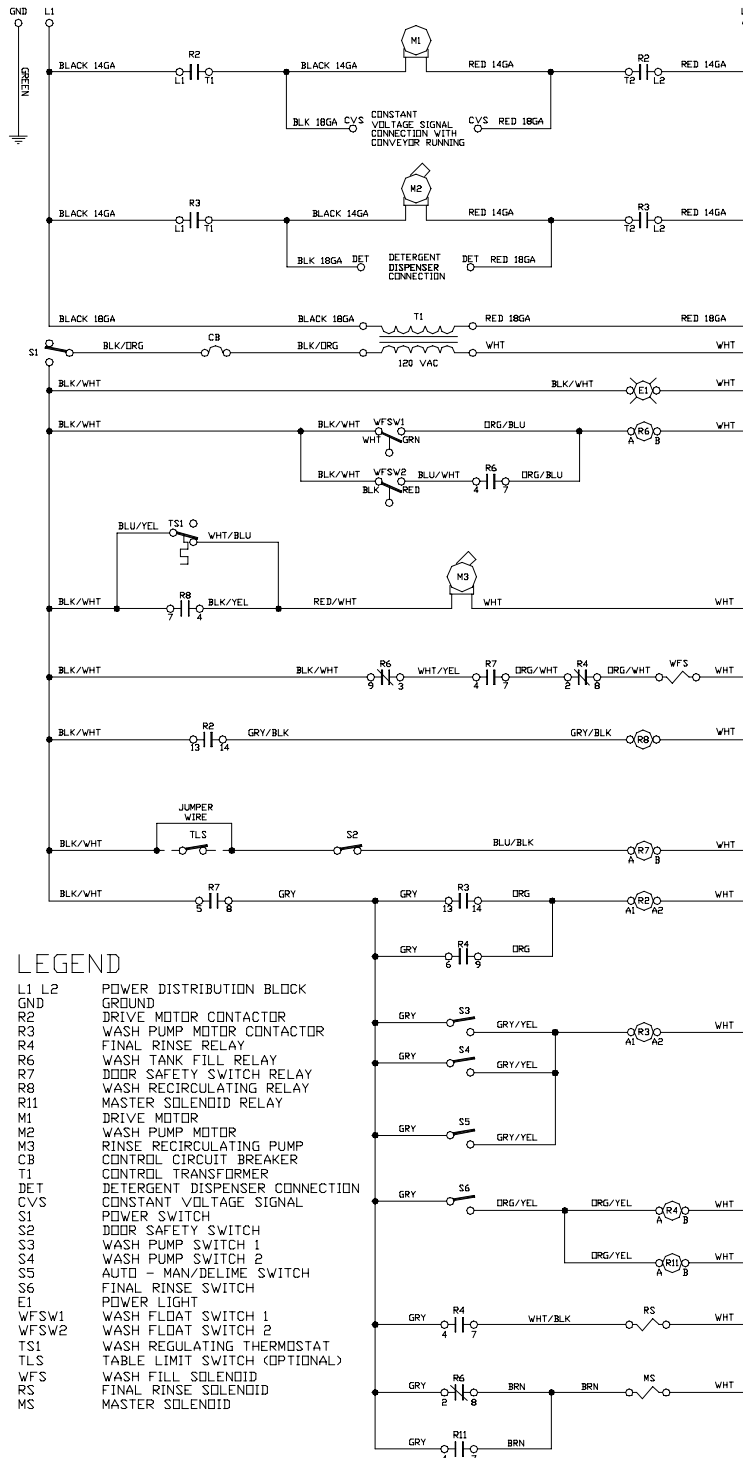

LEGEND

- L1 L2 POWER DISTRIBUTION BLOCK
- GND GROUND
- R2 DRIVE MOTOR CONTACTOR
- R3 WASH PUMP MOTOR CONTACTOR
- R4 FINAL RINSE RELAY
- R6 WASH TANK FILL RELAY
- R7 DOOR SAFETY SWITCH RELAY
- R8 WASH RECIRCULATING RELAY
- R11 MASTER SOLENOID RELAY
- M1 DRIVE MOTOR
- M2 WASH PUMP MOTOR
- M3 RINSE RECIRCULATING PUMP
- CB CONTROL CIRCUIT BREAKER
- T1 CONTROL TRANSFORMER
- DET DETERGENT DISPENSER CONNECTION
- CVS CONSTANT VOLTAGE SIGNAL CONNECTION
- S1 POWER SWITCH
- S2 DOOR SAFETY SWITCH
- S3 WASH PUMP SWITCH 1
- S4 WASH PUMP SWITCH 2
- S5 AUTO - MAN/DELIME SWITCH
- S6 FINAL RINSE SWITCH
- E1 POWER LIGHT
- WFSW1 WASH FLOAT SWITCH 1
- WFSW2 WASH FLOAT SWITCH 2
- TS1 WASH REGULATING THERMOSTAT
- TLS TABLE LIMIT SWITCH (OPTIONAL)
- WFS WASH FILL SOLENOID
- RS FINAL RINSE SOLENOID
- MS MASTER SOLENOID

9905-002-52-42

SECTION 7: ELECTRICAL SCHEMATICS

AJ-54CGP (208-230 VOLT, 60 HZ, THREE PHASE)

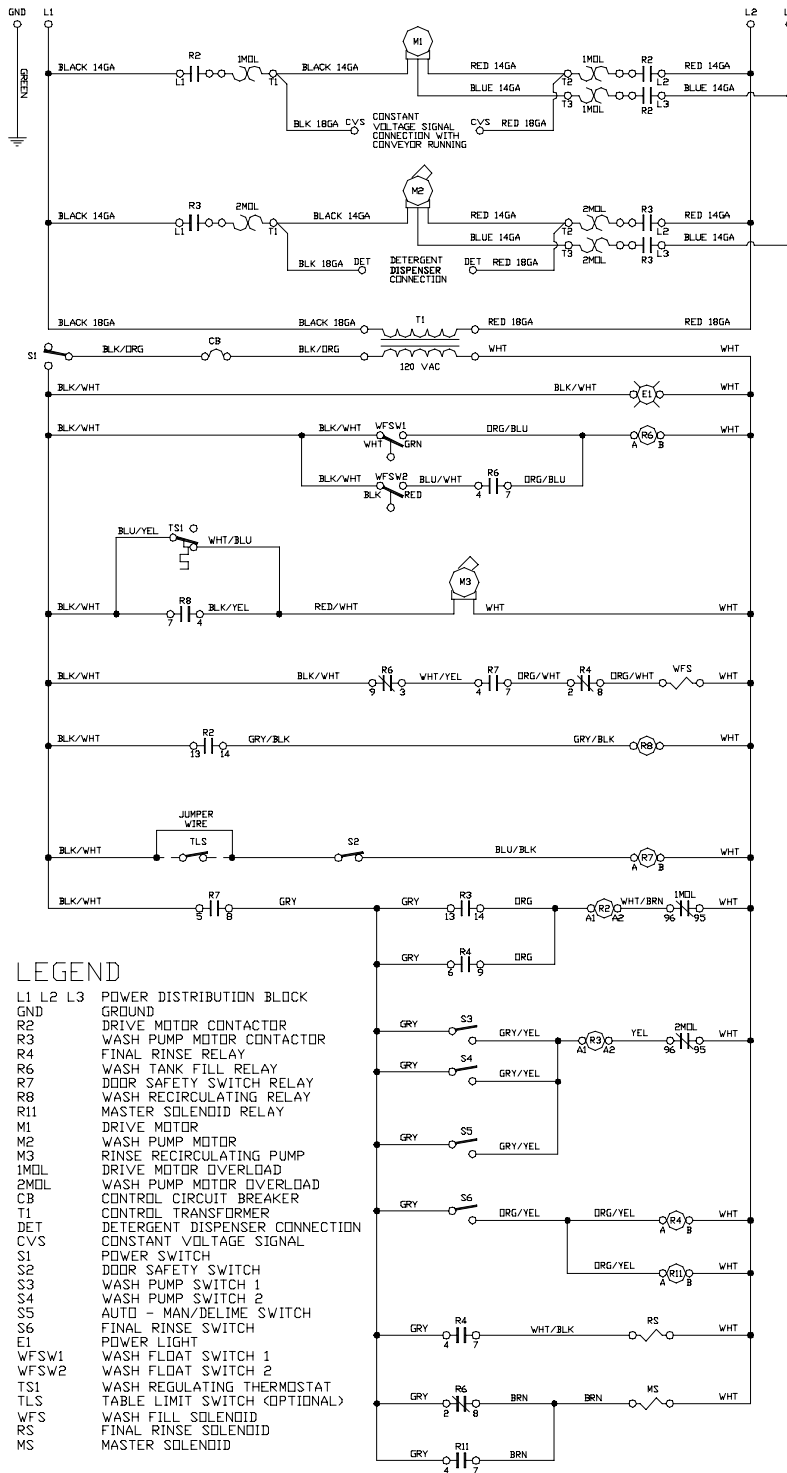

9905-002-33-11a

SECTION 7: ELECTRICAL SCHEMATICS

AJ-54CGP (460 VOLT, 60 HZ, 3 PHASE)

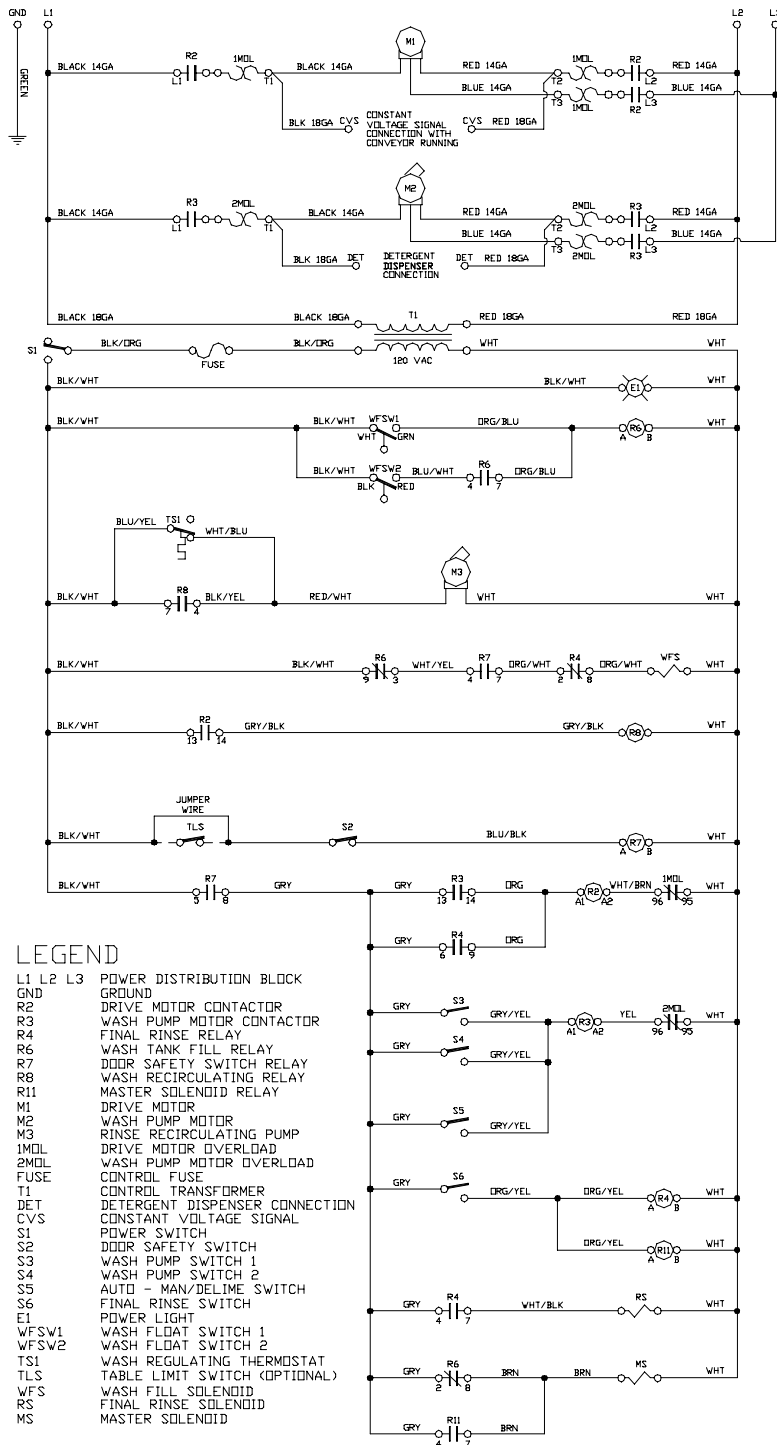

9905-002-53-24

SECTION 7: ELECTRICAL SCHEMATICS

AJ-76CGP (208-230 VOLTS, 60 HZ, SINGLE PHASE)

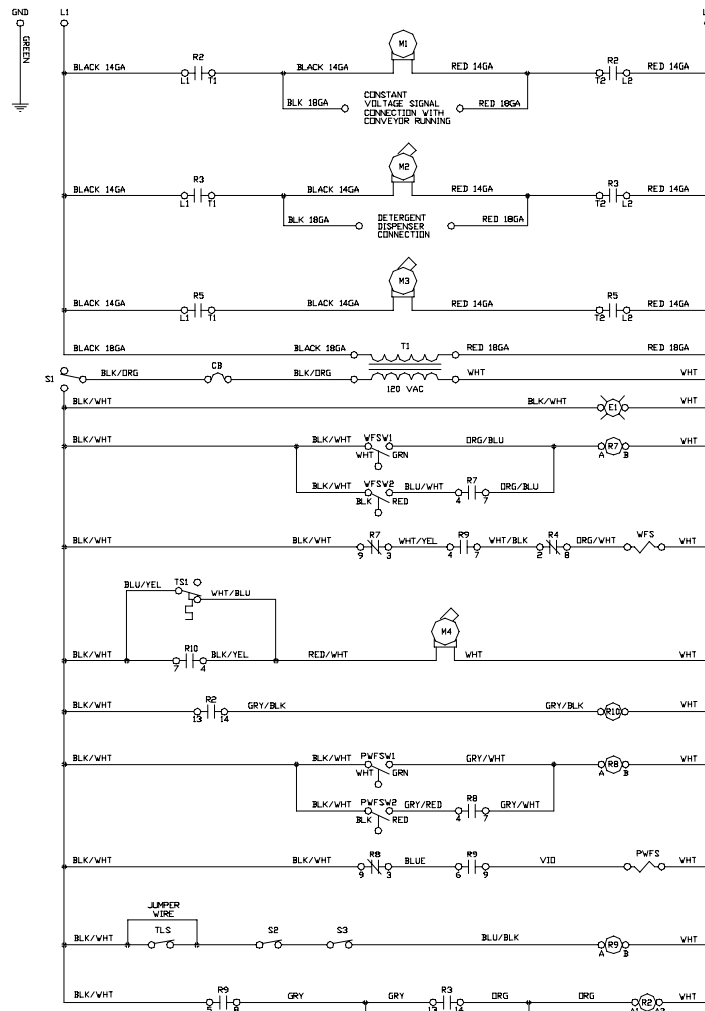

LEGEND

L1 L2	POWER DISTRIBUTION BLOCK
GND	GROUND
R2	DRIVE MOTOR CONTACTOR
R3	WASH PUMP MOTOR CONTACTOR
R4	FINAL RINSE RELAY
R5	PRE-WASH PUMP MOTOR CONTACTOR
R7	WASH TANK FILL RELAY
R8	PRE-WASH TANK FILL RELAY
R9	DOOR SAFETY SWITCH RELAY
R10	WASH RECIRCULATING RELAY
R11	MASTER SOLENOID RELAY
M1	DRIVE MOTOR
M2	WASH PUMP MOTOR
M3	PRE-WASH PUMP MOTOR
M4	RINSE RECIRCULATING PUMP
CB	CONTROL CIRCUIT BREAKER
T1	CONTROL TRANSFORMER
S1	POWER SWITCH
S2	DOOR SAFETY SWITCH 1
S3	DOOR SAFETY SWITCH 2
S4	WASH PUMP SWITCH 1
S5	WASH PUMP SWITCH 2
S6	AUTO - MAN/DELTIME SWITCH
S7	FINAL RINSE SWITCH
S8	PRE-WASH PUMP SWITCH
E1	POWER LIGHT
WFSW1	WASH FLOAT SWITCH 1
WFSW2	WASH FLOAT SWITCH 2
PVFSW1	PRE-WASH FLOAT SWITCH 1
PVFSW2	PRE-WASH FLOAT SWITCH 2
TS1	WASH REGULATING THERMOSTAT
CWTS	COLD WATER THERMOSTAT (OPTIONAL)
CVV	COLD WATER VALVE (OPTIONAL)
TLS	TABLE LIMIT SWITCH (OPTIONAL)
WFS	WASH FILL SOLENOID
PVFS	PRE-WASH FILL SOLENOID
RS	FINAL RINSE SOLENOID
MS	MASTER SOLENOID

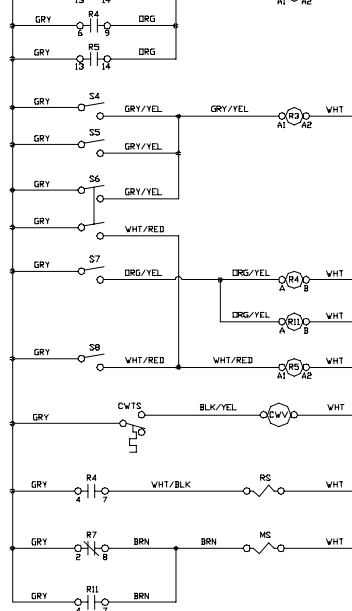

9905-002-53-26

SECTION 7: ELECTRICAL SCHEMATICS

AJ-76CGP (208-230 VOLTS, 60 HZ, THREE PHASE)

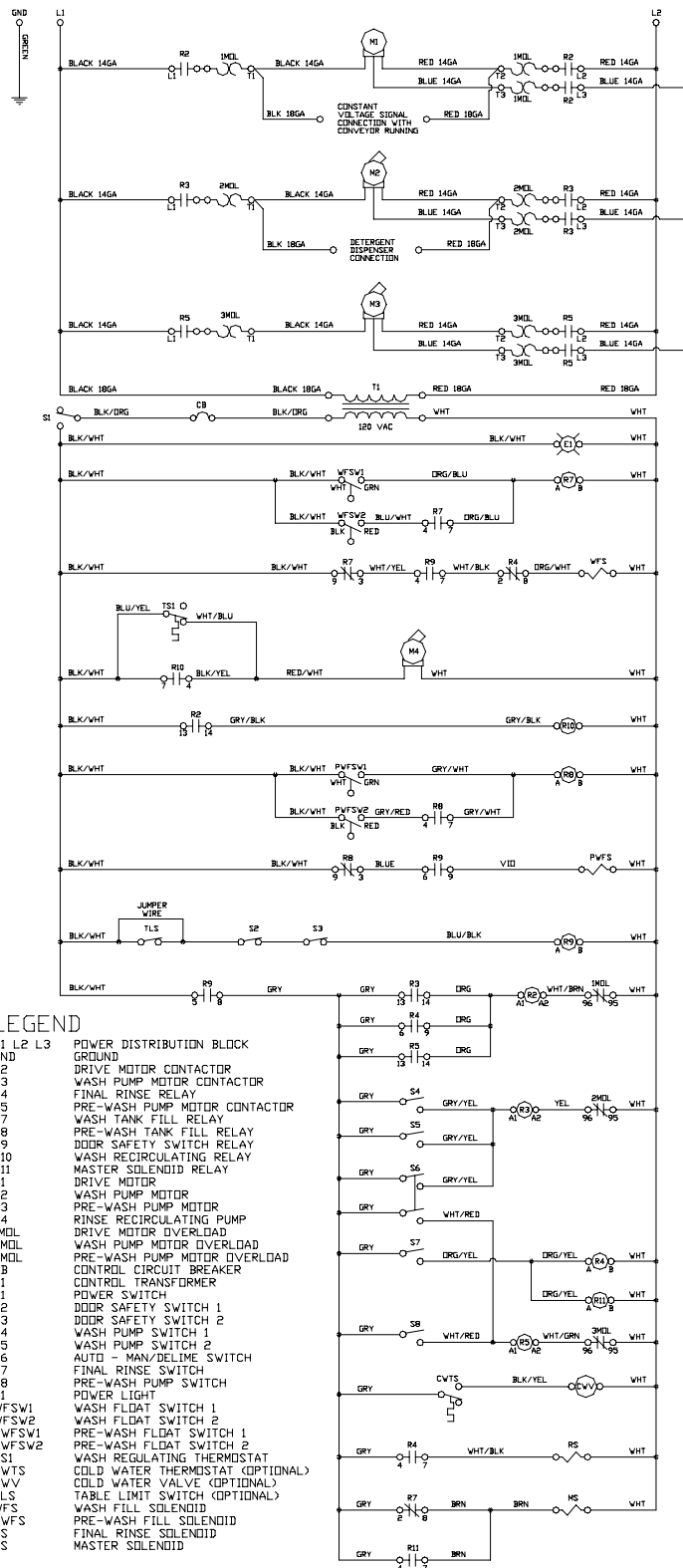

9905-002-33-61c

SECTION 7: ELECTRICAL SCHEMATICS

AJ-76CGP (460 VOLTS, 60 HZ, THREE PHASE)

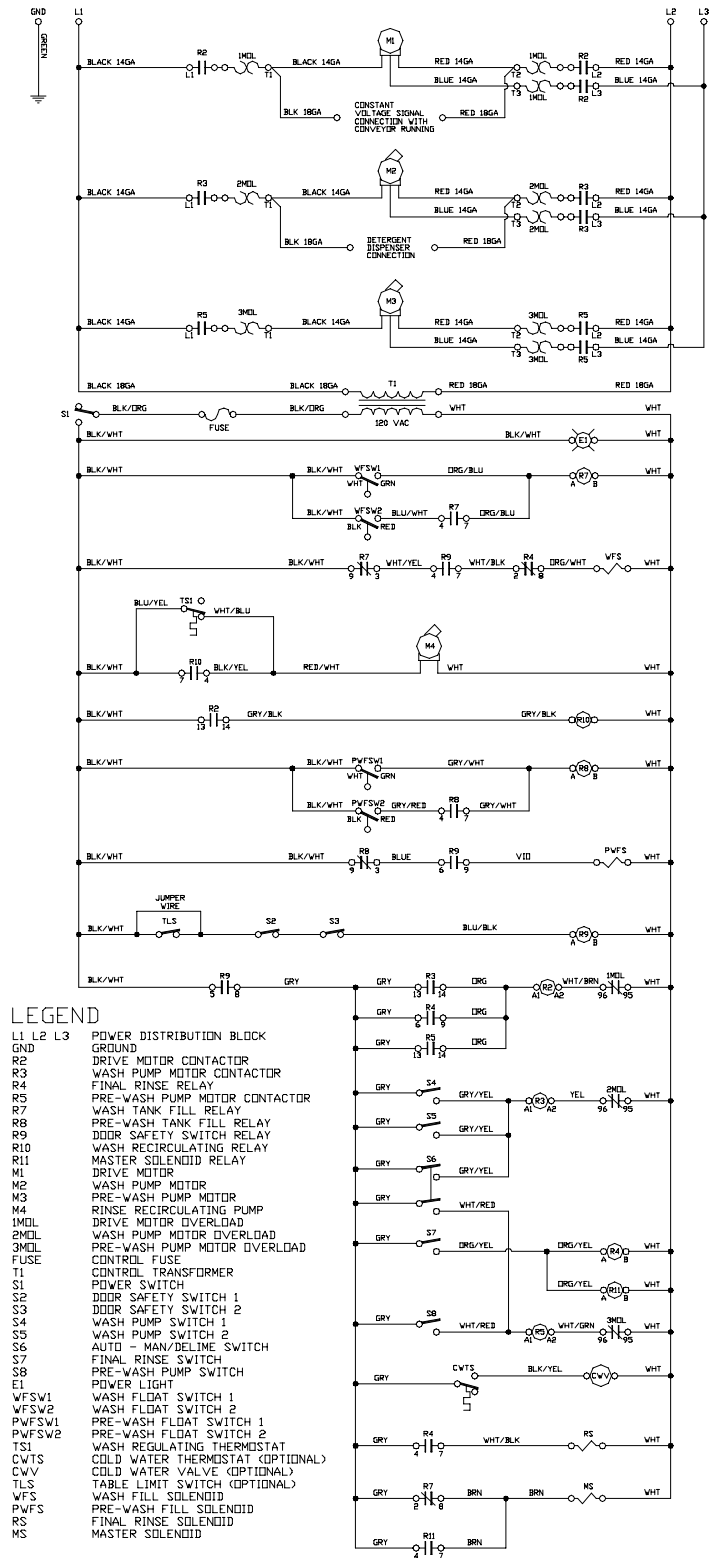

9905-002-53-25

SECTION 7: ELECTRICAL SCHEMATICS
CONVEYOR EXHAUST FAN HOOKUP

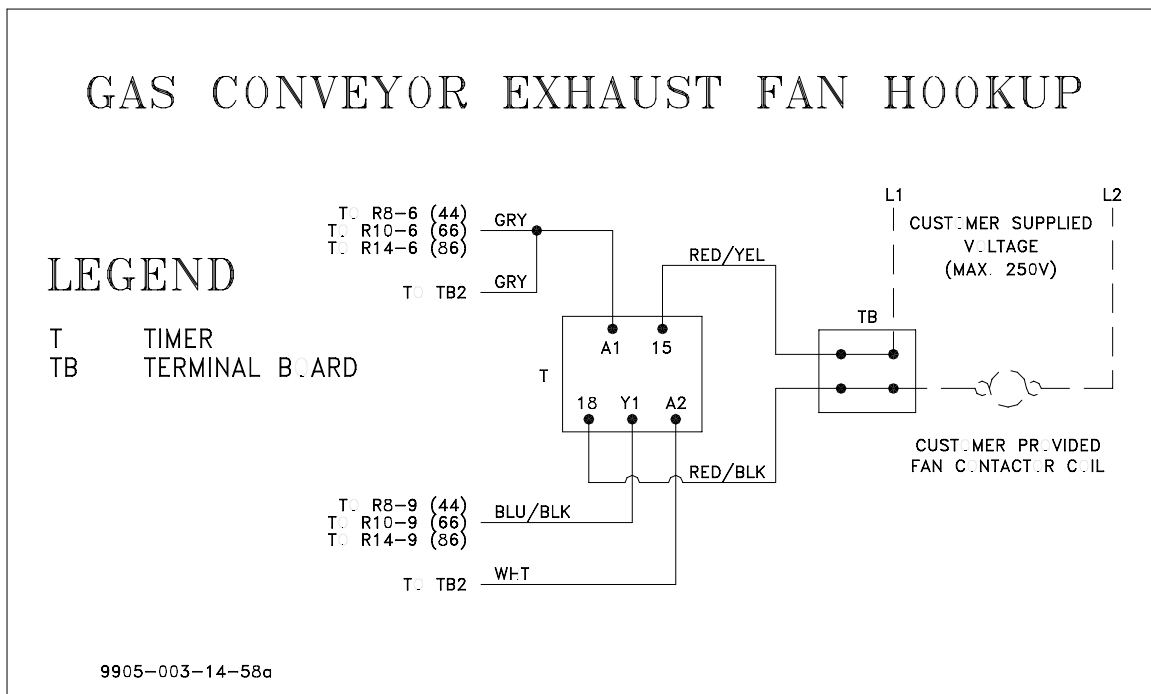
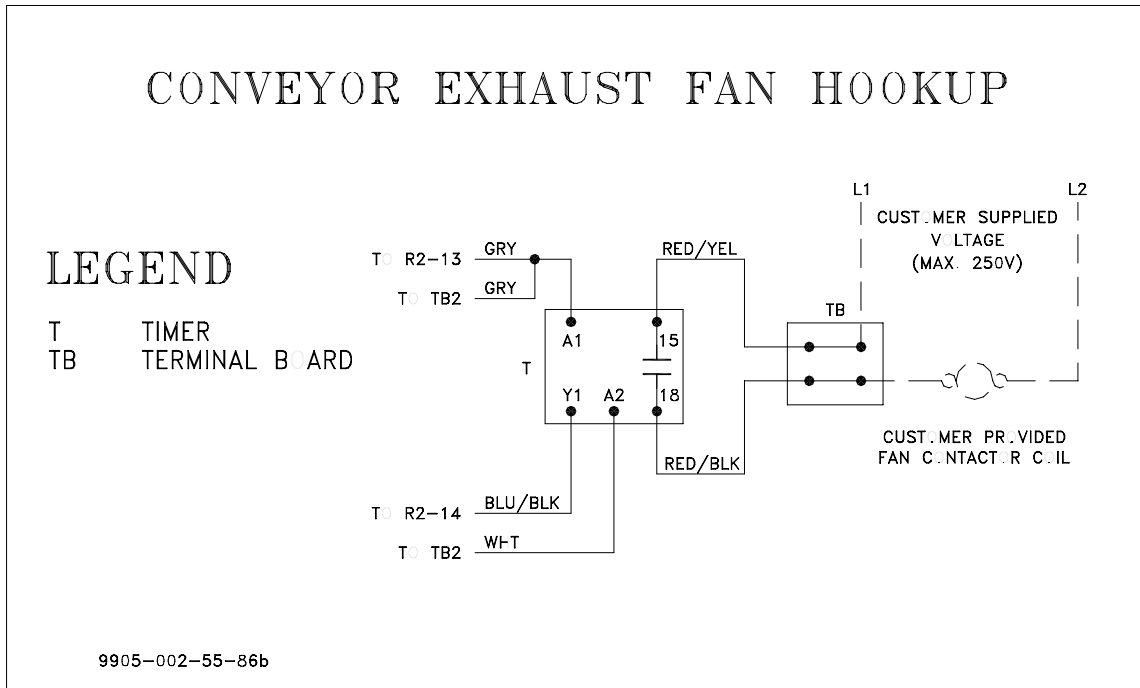

SECTION 7: ELECTRICAL SCHEMATICS

D226 STEAM BOOSTER/DRAIN QUENCH SYSTEM/SIDE LOADER

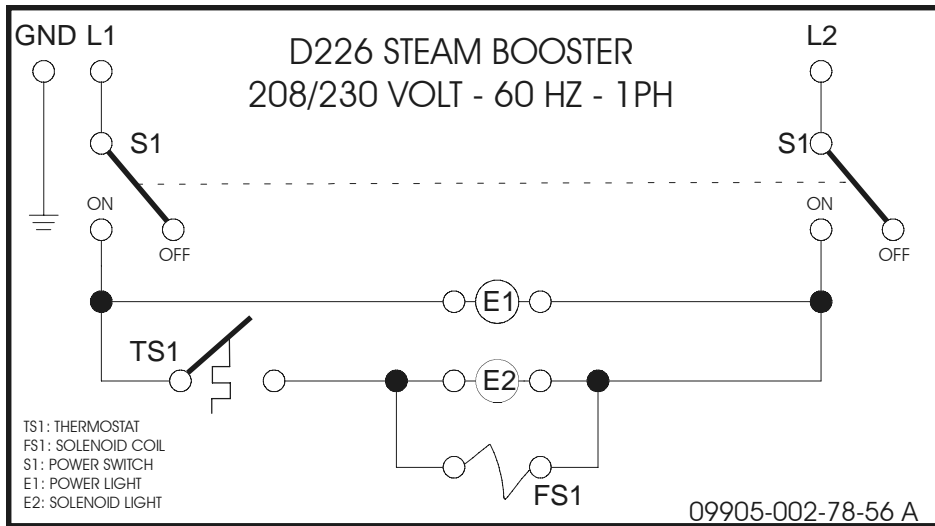

DRAIN QUENCH SYSTEM

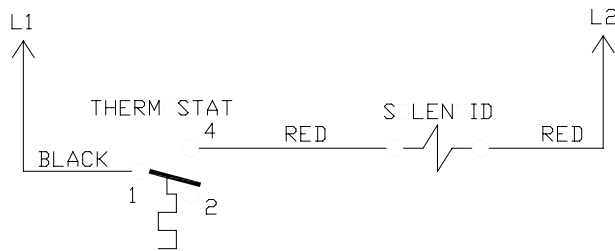

CONNECT BLACK WIRE TO THERM CONTACTOR - L1 WITH PIGGYBACK TERMINAL PROVIDED
CONNECT WHITE WIRE TO THERM CONTACTOR - L2 WITH PIGGYBACK TERMINAL PROVIDED

CONVEYOR SIDE LOADER

54 CONVEYORS

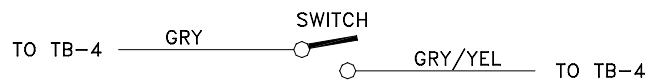

76 & 90 CONVEYORS

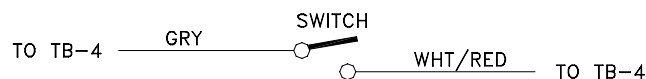

9905-002-56-84a

**SECTION 8:
JACKSON MAINTENANCE
& REPAIR CENTERS**

SECTION 8: JACKSON MAINTENANCE & REPAIR CENTERS

ALABAMA TO FLORIDA

ALABAMA

JONES-McLEOD APPLIANCE SVC

1616 7TH AVE. NORTH
BIRMINGHAM, AL 35203
(205) 251-0159
800-821-1150
FAX: (205) 322-1440
service@jones-mcleod.com

JONES-McLEOD APPLIANCE SVC

854 LAKESIDE DRIVE
MOBILE, AL 36693
(251) 666-7278
800-237-9859
FAX: (251) 661-0223

ALASKA

RESTAURANT APPLIANCE SERVICE

7219 ROOSEVELT WAY NE
SEATTLE, WA 98115
(206) 524-8200
800-433-9390
FAX: (206) 525-2890
info@restappl.com

ARIZONA

AUTHORIZED COMMERCIAL FOOD EQMT. SVC

4832 SOUTH 35TH STREET
PHOENIX, AZ 85040
(602) 234-2443
800-824-8875
FAX: (602) 232-5862
acsboss@aol.com

GCS SERVICE INC.

PHOENIX, AZ
(602) 474-4510
800-510-3497
FAX: (602) 470-4511

ARKANSAS

BROMLEY PARTS & SVC

10TH AND RINGO
P.O. BOX 1688
LITTLE ROCK, AR 72202
(501) 374-0281
800-482-9269
FAX: (501) 374-8352
service@bromleyparts.com
parts@bromleyparts.com

GCS SERVICE, INC.

3717 CHERRY ROAD
MEMPHIS, TN 38118
(901) 366-4587
800-262-9155
FAX: (901) 366-4588

CALIFORNIA

BARKERS FOOD MACHINERY SERVICES

5367 SECOND STREET
IRWINDALE, CA 91706
(626) 960-9390
800-258-6999
FAX: (626) 337-4541
service@barkers.com

GCS SERVICE INC.

LOS ANGELES, CA
(213) 683-2090
800-327-1433
FAX: (213) 683-2099

GCS SERVICE INC.

SANTA ANA, CA
(714) 542-1798
800-540-0719
FAX: (714) 542-4787

GCS SERVICE INC.

S. SAN FRANCISCO, CA
(650) 635-0720
800-969-4427
FAX: (650) 871-4019

COMMERCIAL APPLIANCE SERVICE, INC.

6507 PACIFIC AVENUE, SUITE 102
STOCKTON, CA 95207
(916) 567-0203
(800) 464-2222
(916) 567-0266 FAX

GCS SERVICE INC.

SAN DIEGO, CA
(858) 549-8411
800-422-7278
FAX: (858) 549-2323

INDUSTRIAL ELECTRIC SVC.

5662 ENGINEER DRIVE
HUNTINGTON BEACH, CA 92649
(714) 379-7100
(800-457-3783
FAX: (714) 379-7109

P & D APPLIANCE SVC

100 SOUTH LINDEN AVE.
S. SAN FRANCISCO, CA 94080
(650) 635-1900
800-424-1414
FAX: (650) 635-1919
pndappl@aol.com

P & D APPLIANCE

4220-C ROSEVILLE ROAD
NORTH HIGHLANDS, CA 95660
(916) 974-2772
800-824-7219
FAX: (916) 974-2774

COMMERCIAL APPLIANCE SERVICE, INC.

281 LATHROP WAY, #100
SACRAMENTO, CA 95815
(916) 567-0203
(800) 464-2222
(916) 567-0324 FAX

COLORADO

GCS SERVICE INC.

SHERIDAN, CO
(303) 371-9054
800-972-5314
FAX: (303) 371-4754

HAWKINS COMMERCIAL APPLIANCE SERVICE

3000 S. WYANDOT ST.
ENGLEWOOD, CO 80110
(303) 781-5548
(800) 624-2117
FAX: (303) 761-5561
johns@hawkinscommercial.com

METRO APPLIANCE SERVICE

1640 S BROADWAY
DENVER, CO 80210
(303) 778-1126
800-525-3532
FAX: (303) 778-0268
metroappls@aol.com

CONNECTICUT

GCS SERVICE INC.

HARTFORD, CT
(860) 549-5575
800-423-1562
FAX: (860) 527-6355

SUPERIOR KITCHEN SERVICE INC.

22 THOMPSON ROAD
WINDSOR, CT 06088
(888) 590-1899
(888) 590-1996 FAX

DELAWARE

FOOD SERVICE EQMT.

2101 PARKWAY SOUTH
BROOMALL, PA 19008
(610) 356-6900
FAX: (610) 356-2038
dancerule@aol.com

GCS SERVICE INC.

PHILADELPHIA, PA
(215)925-6217
800-441-9115
FAX: (215) 925-6208

ELMER SCHULTZ SERVICE

36 BELMONT AVE.
WILLMINGTON, DE 19804
(302) 655-8900
800-225-0599
FAX: (302) 656-3673
elmer2@erols.com

EMR SERVICE DIVISION

106 WILLIAMSPORT CIRCLE
SALISBURY, MD 21804
(410) 543-8197
FAX: (410) 548-4038

FLORIDA

COMMERCIAL APPLIANCE SERVICE

8416 LAUREL FAIR CIRCLE
BLDG 6, SUITE 114
TAMPA, FL 33610
(813) 663-0313
800-282-4718
FAX: (813) 663-0212
commercialappliance@world-net.att.net

GCS SERVICE INC

MIAMI, FL
(305) 621-6666
800-766-8966
FAX: (305) 621-6656

GCS SERVICE INC

ORLANDO, FL
(407) 841-2551
800-338-7322
FAX: (407) 423-8425

NASS PARTS AND SERVICE, INC.

1144 BELVILLE ROAD, UNIT 359
DAYTONA BEACH, FL 32114
(386) 226-2642
(800) 432-2795
(386) 736-7695 FAX

GCS SERVICE INC

TAMPA, FL
(813) 626-6044
800-282-3008
FAX: (813) 621-1174

SECTION 8: JACKSON MAINTENANCE & REPAIR CENTERS

FLORIDA TO MARYLAND**JONES-McLEOD APPLIANCE
SVC**

854 LAKESIDE DRIVE
MOBILE, AL 36693
(251) 666-7278
800-237-9859
FAX: (251) 661-0223
service@jones-mcleod.com

**NASS PARTS AND SERVICE,
INC.**

1108 SOUTH WOODS AVENUE
ORLANDO, FL 32805
(407) 425-2681
(800) 432-2795
(407) 425-3463 FAX

**NASS PARTS AND SERVICE,
INC.**

1376 HEIDE AVENUE
PALM BAY, FL 32907
(321) 952-2012
(800) 432-2795
(321) 953-0266 FAX

GEORGIA**GCS SERVICE INC**

ATLANTA, GA
(770) 452-7322
800-334-3599
FAX: (770) 452-7473

HERITAGE FOODSERVICE

GROUP OF ATLANTA
2100 NORCROSS PKWY.
SUITE 130
NORCROSS, GA 30071
(770) 368-1465
866-388-9837
FAX: (866) 388-9838

**WHALEY FOODSERVICE
REPAIRS**

109-A OWENS INDUSTRIAL
DRIVE
SAVANNAH, GA 31405
(912) 447-0827
888-765-0036
FAX: (912) 447-0826

PIERCE PARTS & SERVICE

2422 ALLEN ROAD
MACON, GA 31216
(478) 781-6003
800-368-2512
FAX: (478) 781-7186

HAWAII**FOOD EQMT. PARTS &
SERVICE CO.**

300 PUUHALE RD.
HONOLULU, HI 96819
(808) 847-4871
FAX: (808) 842-1560
fepsco@hula.net

IDAHO**RESTAURANT APPLIANCE
SVC.**

7219 ROOSEVELT WAY NE
SEATTLE, WA 98115
(206) 524-8200
800-433-9390
FAX: (206) 525-2890
info@restappl.com

RON'S SERVICE

703 E 44TH STREET STE 10
GARDEN CITY, ID 83714
(208) 375-4073
FAX: (208) 375-4402

ILLINOIS**CONES REPAIR SVC.**

2408 40TH AVE.
MOLINE, IL 61265
(309) 797-5323
800-716-7070
FAX: (309) 797-3631
jackb@cones.com

EICHENAUER SERVICES INC.

130 S OAKLAND ST.
DECATUR, IL 62522
(217) 429-4229
800-252-5892
FAX: (217) 429-0226
esi@esiquality.com

GCS SERVICE INC.

ELMHURST, IL
(630) 941-7800
800-942-9689
FAX: (630) 941-6048

GCS SERVICE INC.

ST. LOUIS, MO
(314) 683-7444
800-284-4427
FAX: (314) 638-0135

GENERAL PARTS, INC.

248 JAMES STREET
BENSONVILLE, IL 60106
(630) 595-3300
(800) 880-3604
FAX: (630) 595-0006

INDIANA**GCS SERVICE INC.**

INDIANAPOLIS, IN
(317) 545-9655
800-727-8710
FAX: (317) 549-6286

B622 LA PAS TRAIL
INDIANAPOLIS, IN 46268
(317) 290-8060
(800) 410-9794
(317) 290-8085 FAX

IOWA**GOODWIN TUCKER GROUP**

2900 DELAWARE AVENUE
DES MOINES, IA 50317
(515) 262-9308
800-372-6066
FAX: (515) 262-2936
parts@goodwintucker.com

CONES REPAIR SVC.

1056 27TH AVENUE SW
CEDAR RAPIDS, IA 52404
(319) 365-3325
800-747-3326
FAX: (319) 365-0885

KANSAS**GCS SERVICE INC.**

KANSAS CITY, MO
(816) 920-5999
800-229-6477
FAX: (816) 920-7387

GENERAL PARTS, INC.

1101 E. 13TH STREET
KANSAS CITY, MO 64106
(816) 421-5400
(800) 279-9967
(816) 421-1270 FAX

KENTUCKY**CERTIFIED SERVICE CENTER**

127 DISHMAN LANE
BOWLING GREEN, KY 42101
(270) 783-0012
(877) 907-0012
FAX: (270) 783-0058

CERTIFIED SERVICE CENTER

RAMCO BUSINESS PARK
4283 PRODUCE ROAD
LOUISVILLE, KY 40218
(502) 964-7007
800-637-6350
FAX: (502) 964-7202
cwalker@certifiedsc.com
droenigk@certifiedsc.com

CERTIFIED SERVICE CENTER

1051 GOODWIN DRIVE
LEXINGTON, KY 40505
(606) 254-8854
800-432-9269
FAX: (606) 231-7781
jatkings@certifiedsc.com

GCS SERVICE INC.

LOUISVILLE, KY
(502) 367-1788
800-752-6160
FAX: (502) 367-0400

GCS SERVICE INC.

LEXINGTON, KY
(606) 255-0746
800-432-9260
FAX: (606) 255-0748

LOUISIANA**HERITAGE SERVICE GROUP**

1532 RIVER OAKS WEST
NEW ORLEANS, LA 70123
(504) 734-8864
(800) 499-2351
(504) 733-2559 FAX

MAINE**GCS SERVICE INC.**

CHELSEA, MA
(617) 889-9393
800-225-1155
FAX: (617) 889-1222

**MASSACHUSETTS RESTAU-
RANT SUPPLY**

34 SOUTH STREET
SOMERVILLE, MA 02143
(617) 868-1930
800-338-6737
FAX: (617) 686-5331

**PINE TREE FOOD EQUIP-
MENT**

175 LEWISTON ROAD
GRAY, ME 04039
(207) 657-6400
(800) 540-5427
(207) 657-5464 FAX

MARYLAND**EMR SERVICE DIVISION**

700 EAST 25TH STREET
BALTIMORE, MD 21218
(410) 467-8080
800-879-4994
FAX: (410) 467-4191
baltparts@emrco.com

SECTION 8: JACKSON MAINTENANCE & REPAIR CENTERS

MARYLAND TO NEW YORK

EMR SERVICE DIVISION
106 WILLIAMSPORT CIRCLE
SALISBURY, MD 21804
(410) 543-8197
888-687-8080
FAX: (410) 548-4038
baltparts@emrco.com

EMR SERVICE DIVISION
5316 Sunnyside Ave.
Beltsville, MD 20715
(301) 931-7000
800-348-2365
FAX: (301) 931-3060
baltparts@emrco.com

GCS SERVICE INC.
SILVER SPRING, MD
(301) 585-7550 (DC)
(410) 792-0338 (BALT)
(800) 638-7278
FAX: (301) 495-4410

MASSACHUSETTS

ACE SERVICE CO.
95 HAMPTON AVE.
NEEDHAM, MA 02494
(781) 449-4220
800-225-4510 MA & NH
FAX: (781) 444-4789
taceservice@aol.com

**MASSACHUSETTS RESTAU-
RANT SUPPLY**
34 SOUTH STREET
SOMERVILLE, MA 02143
(617) 868-1930
800-338-6737
FAX: (617) 868-5331

GCS SERVICE INC.
CHELSEA, MA
(617) 889-9393
800-225-1155
FAX: (617) 889-1222

GCS SERVICE INC.
HARTFORD, CT
(860) 549-5575
800-723-1562
FAX: (860) 527-6355

**SUPERIOR KITCHEN SER-
VICE INC.**
399 FERRY STREET
EVERETT, MA 02149
(617) 389-1899
(888) 590-1899
(617) 389-1996 FAX

MICHIGAN

GCS SERVICE INC.
LIVONIA, MI
(248) 426-9500
800-772-2936
FAX: (248) 426-7555

**JACKSON SERVICE COMPA-
NY**
3980 BENSTEIN RD.
COMMERCE TWSHP, MI 48382
(248) 363-4159
800-332-4053
FAX: (248) 363-5448

GCS SERVICE INC.
GRAND RAPIDS, MI
(616) 241-0200
800-823-4866
FAX: (616) 241-0541

MINNESOTA

GCS SERVICE INC.
MINNEAPOLIS, MN
(612) 546-4221
800-345-4221
FAX: (612) 546-4286

GENERAL PARTS, INC.
11311 HAMPSHIRE AVENUE
SOUTH
BLOOMINGTON, MN 55438-
2456
(952) 944-5800
(800) 279-9980
(800) 279-9980 FAX

MISSISSIPPI

GCS SERVICE INC.
JACKSON, MS
(601) 956-7800
800-274-5954
FAX: (601) 956-1200

GCS SERVICE INC.
MEMPHIS, TN
(901) 366-4587
800-262-9155
FAX: (901) 366-4588

MISSOURI

GCS SERVICE INC.
KANSAS CITY, MO
(816) 920-5999
800-229-6477
FAX: (816) 920-7387

GCS SERVICE INC.
ST. LOUIS, MO
(314) 638-7444
800-284-4427
FAX: (314) 638-0135

KAEMMERLIN PARTS & SVC.
2728 LOCUST STREET
ST. LOUIS, MO 63103
(314) 535-2222
FAX: (314) 535-6205
petek@kps.stl.com

GENERAL PARTS, INC.
1101 EAST 13TH STREET
KANSAS CITY, MO 64106
(816) 421-5400
(800) 279-9967
(816) 421-1270 FAX

MONTANA

**RESTAURANT APPLIANCE
SVC.**
7219 ROOSEVELT WAY NE
SEATTLE, WA 98115
(206) 524-8200
800-433-9390
FAX: (206) 525-2890
info@restappl.com

NEBRASKA

GOODWIN - TUCKER GROUP
7535 D STREET
OMAHA, NE 68124
(402) 397-2880
800-228-0342
FAX: (402) 397-2881
askme@goodwintucker.com

NEVADA

**HI TECH COMMERCIAL SER-
VICE**
1840 STELLA LAKE STREET
NORTH LAS VEGAS, NV 89106
(702) 649-4616
(877) 924-4832
FAX: (702) 649-4607
larry@hitechnv.com

5454 LOUIE LANE
RENO, NV 89511
(775) 852-9696
FAX: (775) 852-5104

GCS SERVICE INC.
LAS VEGAS, NV
(702) 450-3495
800-500-9060
FAX: (702) 450-3491

NEW HAMPSHIRE

GCS SERVICE INC.
CHELSEA, MA
(617)889-9393
800-225-1155
FAX: (617) 889-1222

ACE SERVICE CO.
95 HAMPTON AVE.
NEEDHAM, MA 02494
(781) 449-4220
800-225-4510 MA & NH
FAX: (781) 444-4789
taceservice@aol.com

**MASSACHUSETTS RESTAU-
RANT SUPPLY**
34 SOUTH STREET
SOMERVILLE, MA 02143
(617) 868-1930
800-338-6737
FAX: (617) 868-5331

NEW JERSEY

JAY HILL REPAIRS
90 CLINTON RD.
FAIRFIELD, NJ 07004
(973) 575-9145
800-836-0643
FAX: (973) 575-5890
jhrepair@aol.com

GCS SERVICE INC.
EAST RUTHERFORD, NJ
(973) 614-0003
800-399-8294
FAX: (973) 614-0230

GCS SERVICE INC.
PHILADELPHIA, PA
(215) 925-6217
800-441-9115
FAX: (215) 925-6208

ELMER SCHULTZ SERVICES
201 W. WASHINGTON AVE.
PLEASANTVILLE, NJ 08232
(609) 641-0317
800-378-1641
FAX:(609) 641-8703
elmer2@erols.com

NEW YORK

**APPLIANCE INSTALLATION
AND SERVICE CORP.**
1336 MAIN STREET
BUFFALO, NY 14209
(716) 884-7425
800-722-1252
FAX: (716) 884-0410
ais@worldnet.att.net

SECTION 8: JACKSON MAINTENANCE & REPAIR CENTERS

NEW YORK TO PENNSYLVANIA

B.E.S.T. INC.

3003 GENESEE STREET
BUFFALO, NY 14225
(716) 893-6464
800-338-5011
FAX: (716) 893-6466
bestserv@aol.com

DUFFY'S EQUIPMENT SVC.

3138 ONEIDA STREET
SAUQUOIT, NY 13456
(315) 737-9401
800-443-8339
FAX: (315) 737-7132
duffyequip@aol.com

NORTHERN PARTS & SVC.

21 NORTHERN AVENUE
PLATTSBURGH, NY 12903
(518) 563-3200
800-634-5005
FAX: (800) 782-5424
info@northernparts.com

GCS SERVICE INC.

BROOKLYN, NY
(718) 486-5220
800-969-4271
FAX: (718) 486-6772

ALL SERVICE KITCHEN

EQUIPMENT REPAIR
10 CHARLES ST.
NEW HYDE PARK, NY 11040
(516) 378-1176
FAX: (516) 378-1735

ALL ISLAND REPAIRS

40-9 BURT DRIVE
DEER PARK, NY 11729
(631) 242-5588
FAX: (631) 242-6102

NORTH CAROLINA

AUTHORIZED APPLIANCE

SERVICECENTER
1020 TUCKASEEGEE RD.
CHARLOTTE, NC 28208
(704) 377-4501
(800) 532-6127
FAX:(704) 377-4504

AUTHORIZED APPLIANCE

SERVICECENTER
800 N. PERSON ST.
RALEIGH, NC 27604
(919) 834-3476
FAX:(919) 834-3477

AUTHORIZED APPLIANCE

SERVICECENTER
904 S. MARSHALL ST.
WINSTON-SALEM, NC 27403
(336) 725-5396
FAX:(336) 721-1289

AUTHORIZED APPLIANCE

SERVICECENTER
104 HINTON AVE.
WILMINGTON, NC 28403
(910) 313-1250
FAX:(910) 313-6130

WHALEY FOODSERVICE

8334-K ARROWRIDGE BLVD
CHARLOTTE, NC 28273
(704) 529-6242
FAX: (704) 529-1558
info@whaleyfoodservice.com

WHALEY FOODSERVICE

REPAIRS
203-D CREEK RIDGE RD.
GREENSBORO, NC 27406
(336) 333-2333
FAX: (336) 333-2533
info@whaleyfoodservice.com

WHALEY FOODSERVICE

REPAIRS
335-105 SHERWEE DRIVE
RALEIGH, NC 27603
(919) 779-2266
FAX: (919) 779-2224
info@whaleyfoodservice.com

WHALEY FOODSERVICE

REPAIRS
6418-101 AMSTERDAM WAY
WILMINGTON, NC 28405
(910) 791-0000
FAX: (910) 791-6662
info@whaleyfoodservice.com

NORTH DAKOTA

GCS SERVICE INC.

MINNEAPOLIS, MN
(612) 546-4221
800-345-4221
FAX: (612) 546-4286

GENERAL PARTS, INC.

10 SOUTH 18TH STREET
FARGO, ND 58103
(701) 235-4161
(800) 279-9987
(701) 235-0539 FAX

OHIO

CERTIFIED SERVICE CENTER

890 REDNA TERRACE
CINCINNATI, OH 45215
(513) 772-6600
800-543-2060
FAX: (513) 612-6600
sbarasch@certifiedsc.com

CERTIFIED SERVICE CENTER

171J-K NORTH HAMILTON RD.
COLUMBUS, OH 43213
(614) 751-3769
(866) 862-1252
FAX: (614) 751-5792
jadkins@certifiedsc.com

CERTIFIED SERVICE CENTER

6025 N. DIXIE DRIVE
DAYTON, OH 45414
(937) 898-4040
(800) 257-2611
FAX: (937) 898-4177
dharvey@certifiedsc.com

COMMERCIAL PARTS & SVC.

OF COLUMBUS
5033 TRANSAMERICA DRIVE
COLUMBUS, OH 43228
(614) 221-0057
800-837-8327
FAX: (614) 221-3622

GCS SERVICE INC.

COLUMBUS, OH
(614) 476-3225
800-282-5406
FAX: (614) 476-1196

ELECTRICAL APPLIANCE

REPAIR SVC.
5805 VALLEY BELT ROAD
CLEVELAND, OH 44131
(216) 459-8700
800-621-8259
FAX: (216) 459-8707
tomr@electapprep.com

OKLAHOMA

HAGAR RESTAURANT EQMT.

1229 W MAIN STREET
OKLAHOMA CITY, OK 73106
(405) 235-2184
800-445-1791
FAX: (405) 236-5592

OREGON

RON'S SERVICE

16364 SW 72ND AVE
PORTLAND, OR 97224
(503) 624-0890
800-851-4118
FAX: (503) 684-6107
robinson@ronsservice.com

PENNSYLVANIA

A.I.S. COMMERCIAL PARTS & SERVICE

1816 WEST 26TH STREET
ERIE, PA 16508
(814) 456-3732
800-332-3732
FAX: (814) 452-4843
aiserie@aol.com

ELMER SCHULTZ SVC.

540 NORTH 3RD STREET
PHILADELPHIA, PA 19123
(215) 627-5400
FAX: (215) 627-5408
elmer2@erols.com

GCS SERVICE INC.

PHILADELPHIA, PA
(215) 925-6217
800-441-9115
FAX: (215) 925-6208

GCS SERVICE INC.

HARRISBURG, PA
(717) 564-3282
800-367-3225
FAX: (717) 564-9286

GCS SERVICE INC.

PITTSBURGH, PA
(412) 787-1970
800-738-1221
FAX: (412) 787-5005

K & D PARTS AND SERVICE CO.

1833-41 N CAMERON STREET
HARRISBURG, PA 17103
(717) 236-9039
800-932-0503
FAX: (717) 238-4367
kdparts-service@paonline.com

CLARK SERVICE & PARTS

306 AIRPORT DRIVE
BOX 10
SMOKETOWN, PA 17576
(717) 392-5590
(717) 392-5735

SECTION 8: JACKSON MAINTENANCE & REPAIR CENTERS

RHODE ISLAND TO WISCONSIN

RHODE ISLAND

GCS SERVICE INC.
EAST PROVIDENCE, RI
(401) 434-6803
800-462-6012
FAX: (401) 438-9400

SUPERIOR KITCHEN SERVICE INC.

669 ELMWOOD AVENUE
PROVIDENCE, RI 02907
(888) 590-1899
(401) 781-1996 FAX

SOUTH CAROLINA

AUTHORIZED APPLIANCE SERVICECENTER

1811 TAYLOR ST.
COLUMBIA, SC 29202
(803) 254-8414
FAX: (803) 254-5146

AUTHORIZED APPLIANCE SERVICECENTER

2249 AUGUSTA RD.
GREENVILLE, SC 29605
(864) 235-9616
FAX: (864) 235-9623

WHALEY FOODSERVICE REPAIRS

I 26&US1
P.O. BOX 4023
WEST COLUMBIA, SC 29170
(803) 791-4420
800-877-2662
FAX: (803) 794-4630
info@whaleyfoodservice.com

WHALEY FOODSERVICE REPAIRS

748 CONGAREE ROAD
GREENVILLE, SC 29607
(864) 234-7011
800-494-2539
FAX: (864) 234-6662
info@whaleyfoodservice.com

WHALEY FOODSERVICE REPAIRS

1406-C COMMERCE PL.
MYRTLE BEACH, SC 29577
(843) 626-1866
FAX: (843) 626-2632
info@whaleyfoodservice.com

WHALEY FOODSERVICE REPAIRS

4740-A FRANCHISE STREET
N. CHARLESTON, SC 29418
(843) 760-2110
FAX: (843) 760-2255
info@whaleyfoodservice.com

SOUTH DAKOTA

GCS SERVICE INC.

MINNEAPOLIS, MN
(612) 546-4221
800-345-4221
FAX: (612) 546-4286

GENERAL PARTS, INC.

10 SOUTH 18TH STREET
FARGO, ND 58103
(701) 235-4161
(800) 279-9987
(701) 235-0539 FAX

TENNESSEE

GCS SERVICE INC.

MEMPHIS, TN
(901) 366-4587
800-262-9155
FAX: (901) 366-4588

GCS SERVICE INC.

NASHVILLE, TN
(615) 244-8050
800-831-7174
FAX: (615) 244-8885

TEXAS

ARMSTRONG REPAIR CENTER

5110 GLENMOUNT DRIVE
HOUSTON, TX 77081
(713) 666-7100
800-392-5325
FAX: (713) 661-0520
gm@armstrongrepair.com

COMMERCIAL KITCHEN REPAIR CO.

1377 N BRAZOS
P.O BOX 831128
SAN ANTONIO, TX 78207
(210) 735-2811
800-292-2120
FAX: (210) 735-7421
brock@commercialkitchen.com

GCS SERVICE INC.

DALLAS, TX
(972) 484-2954
800-442-5026
FAX: (972) 484-2531

GCS SERVICE INC.

HOUSTON, TX
(713)785-9187
800-868-6957
FAX: (713) 785-3979

GCS/STOVE PARTS

2120 SOLANA STREET
FORT WORTH, TX 76117
(817) 831-0381
800-433-1804
FAX: (817) 834-7754
bud@stoveparts.com

UTAH

LA MONICA'S RESTAURANT EQMT. SVC.

6182 SOUTH STRATLER AVENUE
MURRAY, UT 84107
(801) 263-3221
800-527-2561
FAX: (801) 263-3229
lamonica81@aol.com

VERMONT

NORTHERN PARTS & SVC.

4874 S. CATHERINE STREET
PLATTSBURGH, NY 12901
(518) 563-3200
800-634-5005
FAX: (800) 782-5424
info@northernparts.com

GCS SERVICE INC.

CHELSEA, MA
(617)889-9393
800-225-1155
FAX: (617) 889-1222

VIRGINIA

DAUBERS, INC.

7645 DYNATECH COURT
SPINGFIELD, VA 22153
(703) 866-3600
800-554-7788
FAX: (703) 866-4071
daubers@aol.com

GCS SERVICE INC.

SILVER SPRING, MD
(301) 585-7550(DC)
(410) 792-0388(BALT)
800-638-7278
FAX: (301)495-4410

GCS SERVICE INC.

RICHMOND, VA
(804) 672-1700
800-899-5949
FAX: (804) 672-2888

GCS SERVICE INC.

VIRGINIA BEACH, VA
(757) 464-3500
800-476-4278
FAX: (757) 464-4106

WASHINGTON

GCS SERVICE INC.

SEATTLE, WA
(206) 763-0353
800-211-4274
FAX: (206) 763-5943

RESTAURANT APPLIANCE SERVICE

7219 ROOSEVELT WAY, NE
SEATTLE, WA 98115
(206) 524-8200
800-433-9390
FAX: (206) 525-2890
info@restappl.com

WEST VIRGINIA

STATEWIDE SERVICE, INC.

603 MAIN AVE.
NITRO, WV 25143
(304) 755-1811
(800) 441-9739
FAX: (304) 755-4001
sws3182@aol.com

WISCONSIN

APPLIANCE SERVICE CENTER, INC.

2439 ATWOOD AVE
MADISON, WI 53704
(608) 246-3160
800-236-7440
FAX: (608) 246-2721
ascmad@execpc.com

APPLIANCE SERVICE CENTER, INC.

6843 W. BELOIT RD.
WEST ALLIS, WI 53219
(414) 543-6460
800-236-6460
FAX: (414) 543-6480
ascmil@execpc.com

APPLIANCE SERVICE CENTER

786 MORRIS AVE
GREEN BAY, WI 54304
(920) 496-9993
800-236-0871
FAX: (920) 496-9927
ascfox@execpc.com

SECTION 8: JACKSON MAINTENANCE & REPAIR CENTERS

WISCONSIN TO WYOMING/INTERNATIONAL

GENERAL PARTS, INC.

W223 N735 SARATOGA DRIVE
WAUKESHA, WI 53186
(262) 650-6666
(800) 279-9946
(262) 650-6660 FAX

WYOMING

HAWKINS COMMERCIAL APPLIANCE SERVICE

3000 S. WYANDOT ST.
ENGLEWOOD, CO 80110
(303) 781-5548
(800) 624-2117
FAX: (303) 761-5561
johns@hawkinscommercial.com

METRO APPLIANCE SERVICE

1640 S BROADWAY
DENVER, CO 80210
(303) 778-1126
800-525-3532
FAX: (303) 778-0268
metroappls@aol.com

INTERNATIONAL

GLOBAL PARTS AND SUPPLY

7758 NW 72ND ST
MIAMI, FL 33166
(305) 885-6353

H.D. SHELDON AND CO

19 UNION SQUARE, WEST
NEW YORK, NY 10003
(212) 627-1759
(212) 924-6920

CANADA

THE GARLAND GROUP

1177 KAMATO ROAD
MISSISSAUGA, ONTARIO L4W
1X4
(905) 206-8380
SALES
(905) 624-1419
FAX: (905) 624-1851
SERVICE
800-427-6668
FAX: 800-361-7745

March 13, 2007

