



## **TECHNICAL MANUAL**

Installation, Operation and Maintenance Instructions

### **COMMANDER 18-2**

**HIGH TEMPERATURE DOOR TYPE**

Insinger Machine Company  
6245 State Road  
Philadelphia, PA 19135-2996

**800-344-4802**  
Fax: 215-624-6966  
[www.insingermachine.com](http://www.insingermachine.com)

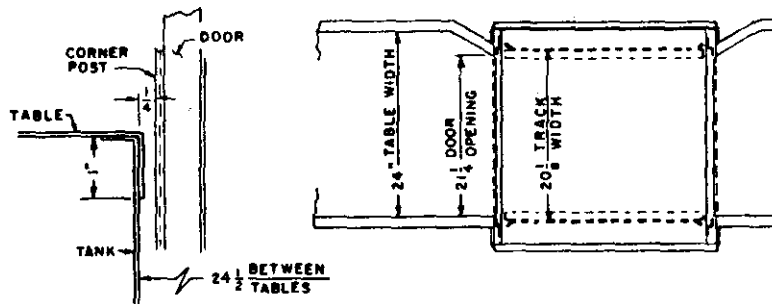
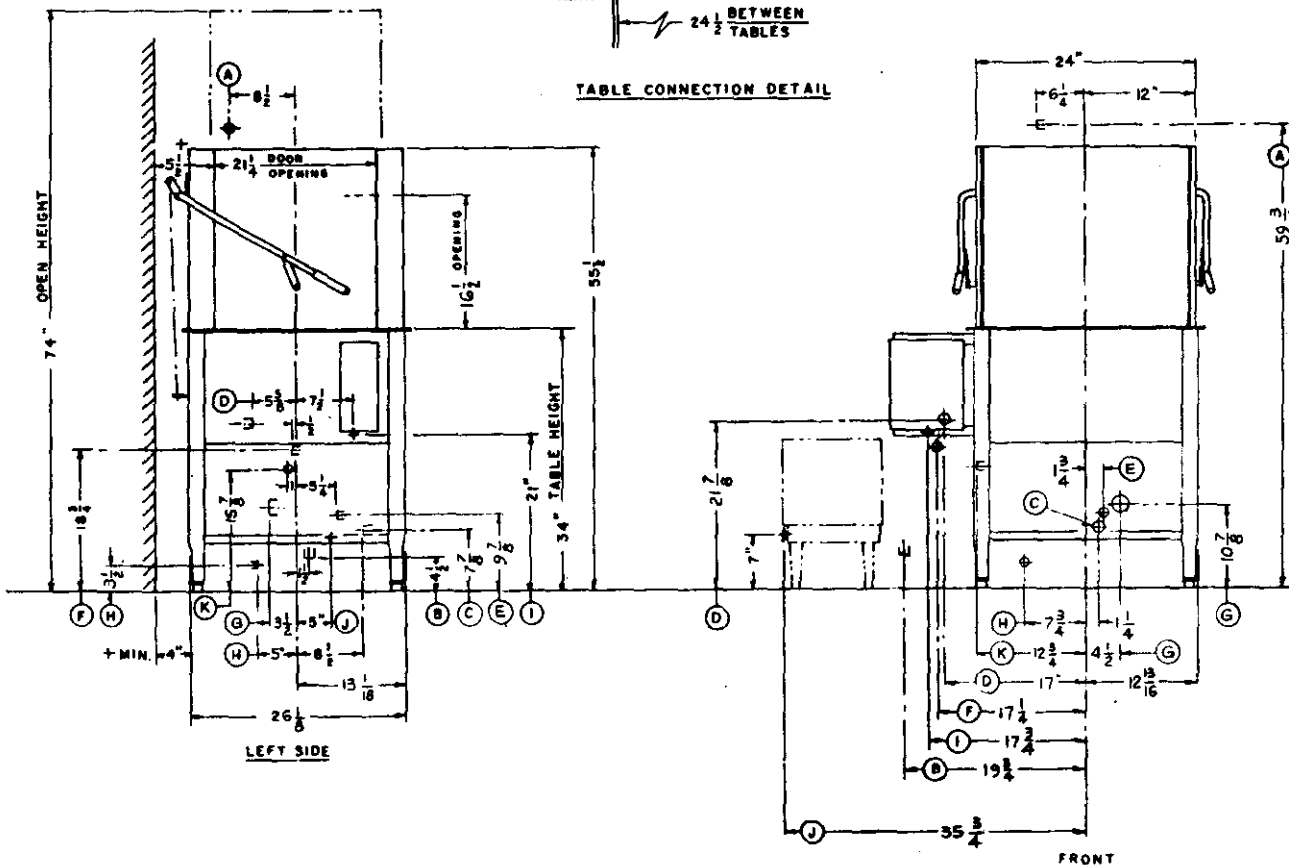

TABLE CONNECTION DETAIL



INSTALLATION CONNECTIONS		
LTR	NAME	SIZE
A	HOT WATER TO FINAL RINSE - 180°F	3/4 FEM. IPS
B	HOT WATER TO ELECTR. BOOST. - 140°F	3/4 FEM. IPS
C	HOT WATER TO STEAM BOOSTER - 140°F	3/4 FEM. IPS
D	STEAM TO TANK	1/2 FEM. IPS
E	STEAM TO BOOSTER	1/2 FEM. IPS
F	GAS CONNECTION	3/4 FEM. IPS
G	DRAIN CONNECTION	2\"/>

\* ADD 5 KW FOR ELECTRIC HEAT.  
 \* 15 KW FURNISHED WHEN SPECIFIED.

**NOTE:**

1. WHEN A GAS HEATED MACHINE IS SPECIFIED, ALLOW 2 FT. MIN. CLEARANCE FROM A VERTICAL COMBUSTIBLE WALL.
2. WASH TANK IS FILLED THRU THE FINAL RINSE LINE.
3. MAGNETIC STARTER WITH OVERLOAD FURNISHED MOUNTED AND INTERWIRED.
4. BOOSTER INSTALLATION CONNECTIONS SHOWN ARE FOR INSINGER STEAM HEAT EXCHANGE STYLE BOOSTER OR 12 KW COMPACT ELECTRIC BOOSTER.

**COMMANDER 18-2**  
 AUTOMATIC  
 DISHWASHING MACHINE

INSINGER MACHINE CO.  
 PHILADELPHIA, PA., 19133

DRAWN BY RAF 4-27-64  
 CHECKED \_\_\_\_\_  
 APPROVED \_\_\_\_\_

DWG. B355

## Detail Specifications — Commander 18 Dishwasher

### Capacity:

55—20"x20" racks per hour, 1375 dishes per hour.

### Design:

Automatic door type with timed wash-and-rinse cycle. Designed for left to right or right to left operation, corner available. Two operating doors in addition to large inspection cleanout door.

### Construction:

Hood and tank of 16 gauge type 302 18-8 stainless steel. Hood unit all welded construction. All internal castings are non-corrosive Ni412<sup>®</sup> non-ferrous nickel alloy. Stainless steel tracks, stainless steel scrap screens, suction strainer, all stainless steel brackets and supports.

### Doors

Three doors—front inspection/cleanout door and two simultaneously opening operating doors. Operating doors, with fingertip control, balanced by externally mounted springs, eliminating all pulleys, chains and rollers.

### Control

NEMA 12 solid state electrical control box houses automatically timed wash and rinse controls mounted on the left side of machine. (Cycle set at 45 sec wash, 3 sec delay, then 12 sec rinse.) After power switch is turned on, dishwasher fills and operates automatically by closing the doors. Interlock prevents operation when front door is left open.

### Pump

Insinger built centrifugal type "packless" ball-bearing pump. Construction includes ceramic type seal, stainless steel parts mounted with balanced impeller on a precision ground shaft. All pump working parts are mounted as an assembly and removable as a unit without disturbing pump housing. Pump has easily removable front and end plates for cleaning and inspection. Re-circulating wash pump capacity of 174 gallons per minute. (Pump rating actual re-circulating inside machine, not open weir.)

### Tank

Capacity to overflow level, 22.0 gallons.

### Motor

(1) 1 HP motor. Motor is standard frame horizontal C-Face mounted. Motor is squirrel-cage induction run type, 60 cycle, 1725 RPM, internally fan cooled with ball-bearing construction.

### Spray System

Wash—three rotating arms above and three rotating arms below. Power wash arms designed for high pressure mechanical washing action. Wash arms removable without the use of tools.

### Final Rinse

Rinse—four rotating nozzles below and five stationary nozzles above with total rack coverage water pattern.

### Overflow & Drain

Functionally designed 17" skimmer with cleanout cap automatically skimming water surface. Drain valve is externally controlled. Overflow and drain assemblies removable without the use of tools for drain line inspection.

### Accessory Tank Heat (as specified.)

### Steam Injector

Silent steam injector fitted with air supply tube and automatic throttling type thermostat control.

### Electric Immersion Heater

5KW housed in Inconel sheath with remote mounted thermostat coupled with stainless steel ball float positive low water cutoff.

### Under Fired Gas Burner

21,000 BTU gas burner, baffle and built-in flue, down draft eliminator thermostatic control, safety pilot, stainless steel ball float positive low water cutoff.

### Standard Equipment

Two plate racks, one cup and bowl rack, one silver rack, eye level thermometers, vacuum breaker, cleanout brush, automatic tank fill, door interlock, front panel, control located on left side.

### Equipment Check List

- Steam Injector with thermostatic control
- Steam Coil with thermostatic control
- Gas with thermostatic control and positive low water cutoff and safety pilot.
- Electric immersion heater 5KW with thermostatic control and positive low water cutoff
- Steam booster
- Electric booster

### Optional Accessory Equipment

- Pressure reduction valve and 3/4" line strainer
- Control box located on right side
- S/S legs
- S/S base frame

*We reserve the right to substitute materials subject to availability and Federal critical classification.*

RATED CAPACITY		OPERATION	TANK CAP GALS	PUMP CAPACITY SINGLE CHAMBER GPM	MOTOR HP	GAS BTU INPUT	STEAM USED LBS./HR. 10 PSI (MIN.)		ELECTRIC HEATER CONSUMPTION KW	FINAL RINSE CONSUMPTION		EXHAUST C.F.M.		DIST. BETWEEN TABLES
RACKS/HOUR	DISHES/HOUR						TANK HEAT	BOOSTER		GPM 20 P.S.I. FLOWING	GALS. PER HR.	WALL HOOD 100 C.F.M. PER SQ. FT.	ISLAND HOOD 150 C.F.M. PER SQ. FT.	
55	1375	MANUAL FEED—right or left hand or corner if specified	22	174	1	21,000	42	65	5	9	120			29"



Insinger Dishwashers . . . at sea with the U.S. Navy for more than 50 years.

# INSINGER

## MACHINE COMPANY

6245 State Road • Philadelphia, Pa 19135  
Telephone (215) 624-4800 • TWX-710-670-1233

Your nearest source for Insinger equipment is:

## NSINGER DISHWASHING MACHINE INSTALLATION INSTRUCTIONS

**PLACEMENT:** Uncrate machine carefully. Take caution not to damage component accessories which usually are appended to side of machine. Set machine in place and adjust feet as needed to set machine level. Most installations require fastening the turn-down lip of table to side of machine tank with flathead counter-sunk screws. The design of the tables should provide horizontal clearance underneath the table to allow 30" for servicing of electrical components. Under-shelves and drain troughs should also allow 30" free access to electrical parts.

If the machine is installed in a high humidity area, an overhead exhaust system will aid drying time.

**ELECTRICAL CONNECTIONS:** Connect electric lines suitable for proper amps, and check to be sure supply voltage and phase agrees with machine requirements indicated on identification tags, labels on terminal boxes or motor name plate. Check motor rotation. (CAUTION - do not run pump over 30 seconds without water in tank.) Motors should drive pumps in direction indicated by arrows cast in pump bodies. Additional connections may be required for electrically operated automatic controls. In all cases, connect to circuit breaker panel or fused disconnect switch (furnished by user) as required by local area codes. Wiring diagram is located inside control box.

**MECHANICAL CONNECTIONS:** Water and steam (if used) supply lines size should be at least as specified. Flush all lines prior to connection to remove debris in lines which will clog both manual and automatic valves. It is important not to reduce size of manufacturer's connection as steam supply and final rinse lines are particularly sizes to provide a stipulated rate of flow.

Pressure on the final rinse water connection should be 20 P.S.I. flowing (measured by pressure gauge with line open). Connect drain line to size not less than manufacturer's connection. Drain line should be properly vented and should have fall of not less than 1/4" to the foot for proper flow. Some area codes require drain to flow into open gap with opening twice the diameter of pipe connection. Connect waste to 2" I.P.S. waste line preferably to open gap floor drain.

## OPERATING INSTRUCTIONS

1. Close drain valve.
2. Open water supply valve and turn electricity on. If machine is heated by gas, open appropriate supply valve. Check that gas pilot is burning.
3. Properly install all internal removable components. (Suction strainer, scrap screens, spinners, etc.)
4. Pour 1 cup of sudsless detergent into tank, or turn on detergent dispenser as required.
5. Lower all doors and move power switch to "On" Position. Machine will fill with proper amount of wash water, run thru a complete wash-rinse cycle and shut off automatically. This cycle will mix the detergent and clean out the manifolds.
6. Open steam valve on steam heated machine. (Temperature controlled automatically by "Power On" switch on Gas or Electrically Heated machines). Machine may be equipped with a low temperature cut-off and will not operate until proper temperatures are reached (150°F. wash, or 180°F. rinse).
7. Insert rack of soiled dishware in machine and lower doors. Machine will wash, rinse and shut off automatically. Indicator light will go off when cycle is complete.
8. Raise side doors and remove rack of clean dishware.
9. For continuous operation, repeat steps 7 and 8. Add approximately 1/2 cup of detergent after every ten cycles when machine is not equipped with automatic detergent dispenser.

---

## GENERAL INSTRUCTIONS

1. Remove scraps from all dishware before placing in racks.
2. Maintain approx. 150° wash and 180° rinse temperatures.
3. Turn off tank heat before draining machine.
4. After use, clean and replace all internal removable parts.
5. When necessary, pump can be cleaned out by removing inspection plate.
6. Shut off water, electric, gas and steam supply when machine is not in use.

## CLEANING INSTRUCTIONS

For the best results, your Insinger dishwasher should be cleaned after each meal. The simple steps outlined below will insure clean, sanitized dishware.

1. Before cleaning, shut off the steam, water and electrical supplies.
2. Open drain(s) and wait until tank(s) are empty.
3. Remove wash manifolds, rinse manifolds, scrap screens, suction strainers, and overflow tubes.
4. Clean dishwasher tank(s) preferably by using a hose. Be careful not to bend or twist any ball float arms. Wipe down inside of hood.
5. Clean and replace suction strainers, and overflow tubes.
6. Clean and replace scrap screens
7. Clean all spray pipes using the brush provided with machine. The end caps must first be removed.
8. Replace caps and install manifolds in their proper positions.
9. Wipe down outside of hood.

It is sometimes necessary to remove lime deposits which may build up over a period of time. There are several excellent de-liming solutions on the market. Follow the instructions from the manufacturer.

INSINGER MACHINE CO.  
6245 State Rd.  
Phila., PA 19135

**INSINGER DISHWASHING MACHINES**  
**BASIC SERVICE GUIDE**

---

1. Machine will not operate
  - (a) Check power supply.
  - (b) Possible blown fuse or circuit breaker
  - (c) Power could be shut off at disconnect switch
  - (d) On units with manual reset overload protection, press reset button and try again.
2. Tank will not hold water
  - (a) Check that drain petcock at base of pump is closed.
  - (b) Check for proper seating of drain valve.
  - (c) Check condition of drain seat cup seals.
3. Tank overflows - Fills past overflow
  - (a) Check overflow pipe for obstructions.
  - (b) See that drain line is clear by opening drain valve. If water still does not go down, the drain pipe must be cleaned.
4. Water leaks from around door
  - (a) Check for proper seating of door
  - (b) Check for clogged spray pipes. Clean with brush provided with machine.
5. Weak or ineffective spray
  - (a) Could be clogged spray pipes - Clean as described above.
  - (b) Check for proper placement of spray pipes, upper pipes should spray down and lower pipes should spray up.
  - (c) Check for rag or other foreign material caught in pump. This may occur when machine is operated without pump suction strainer in place.
  - (d) Check for proper rotation of pump. Arrow on pump indicates direction.
6. Inadequate rinse spray
  - (a) Spray nozzles could be coated with lime and require cleaning.
  - (b) Water pressure may be low. Should be 15 to 20 PSI flowing pressure.
  - (c) Line strainer may be clogged.
  - (d) Check supply valve. It may be closed.
7. Rinse will not shut off
  - (a) Disassemble rinse valve and clean internal parts of lime and scale. Also check disc and seat for wear - replace if necessary.
  - (b) Check that power is released from solenoid type valves at end of cycle.
8. Water hammer
  - (a) Check for excess line pressure
  - (b) Shock absorbing air chambers may be required.

INSINGER MACHINE CO.  
6245 State Rd.  
Phila., PA 19135

## MAINTENANCE & REPAIR INSTRUCTIONS

COMMANDER 18 - 2

1. MAINTENANCE: This machine has all sealed bearing and requires no lubrication. For best results, it should be cleaned by scullery personnel per the following schedule:
  - a- DAILY: Drain machine completely after use and remove spinner assemblies, scrap screens, drain overflow tube and drain strainers. Clean all waste from these parts, flush out the tank and re-assemble. Leave doors open when machine is not in use.
  - b. WEEKLY: Wipe down the superstructure using a good grade stainless steel cleaner. DO NOT HOSE MACHINE.
  - c. SEMI-ANNUALLY: Remove and clean or replace strainer screens on steam lines and incoming water supply line. Inspect condition of valve seats and packing on supply valve and drain valve.
  
2. REPAIR : - Most common problems are covered in the Basic Service Guide (enclosed). The service indicated in this Guide can be performed by building maintenance men. If the machine still will not operate properly after using this Guide, a qualified dishwasher serviceman should be called in.
  
3. MAINTENANCE PROCEDURES
  - a. How to disassemble the solenoid valve
    1. Disconnect power supply to machine. Shut off water supply.
    2. Remove cap on top of coil
    3. Remove coil
    4. Unscrew four (4) hexagon bolts and lift out bonnet from valve body. Note positioning of spring and pilot plunger.
    5. Remove main piston.

## MAINTENANCE & REPAIR INSTRUCTIONS CONTINUED

6. Inspect for dirt, wear, lime build-up or bent spindle.  
Clean or replace as required.
  7. Reassembly is reverse of disassembly procedure.
- b. How to disassemble strainer for cleaning
1. Shut off water or steam supply
  2. Open large hex nuts at bottom of strainer body. Strainer screen can now be removed from the line.
  3. Remove screen, inspect, clean or replace
  4. When re-assembling, be sure the strainer screen is installed in proper direction. Use new gaskets to insure a tight seal.
- c. Disassembly of pump -
1. Before attempting to disassemble pump, it is advisable to remove suction strainer (inside tank) and see if the trouble could be caused by a foreign object which may have been sucked into the pump.
  2. Working parts of pump can be serviced by removing the pump motor and impeller adaptor (held on by (4) 3/8 dia hex head cap screws.)  
IT IS NOT NECESSARY TO REMOVE PUMP BODY FROM THE MACHINE.
  3. Repair or replace pump adaptor as required. Always use a new "O" ring whenever adaptor assembly has been removed.

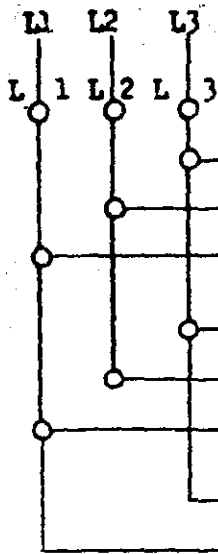

Note: Line connections shown for 3-phase  
For 1 Phase connect lines to L1 & L3 only.

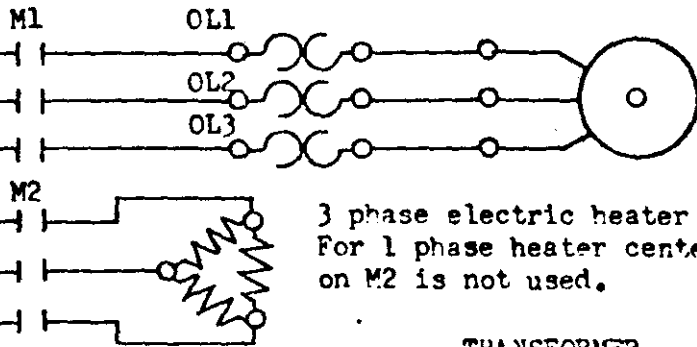

3 phase motor shown, for 1 phase use OL1 & OL3 only.

3 phase electric heater shown (if used)  
For 1 phase heater center contact on M2 is not used.

**TRANSFORMER**

Primary Connections

430 Volts

L1 = H1      u2 & u3 together

240 Volts

L1 = H1 & H3

L2 = H2 & H4

380 Volts

L1 = H1

L2 = H3

POWER SWITCH      CIRCUIT BREAKER

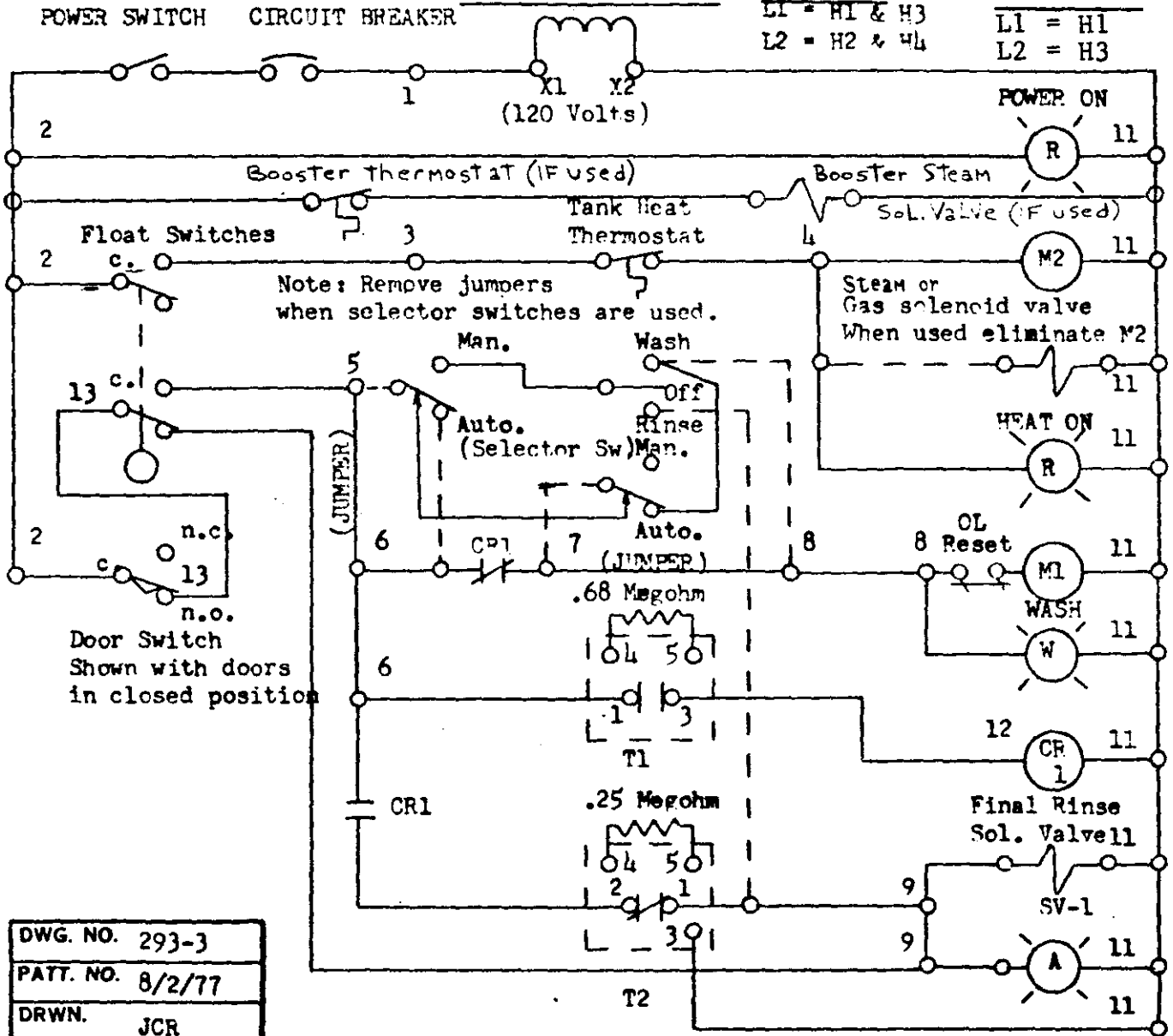

Note: Remove jumpers when selector switches are used.

Door Switch  
Shown with doors  
in closed position

DWG. NO.	293-3
PATT. NO.	8/2/77
DRWN.	JCR
CHKD.	
APPD.	

**INSINGER MACHINE CO.**  
PHILA., PA. 19135

NO.	NAME	PART NO.	REQ.
1	TIMER	DE 7-5	1
2	TIMER	DE 7-6	1
3	RESISTOR	DE 9-11	1
4	RESISTOR	DE 9-12	1
5	TRANSFORMER	DE 6-2	1
6	RELAY BASE	DE 2-7	1
7	RELAY	DE 2-6	1
8	CONTACTOR	DE 1-10	2
9	TERMINAL BLK.	DE 3-6	1
10	INSULATOR	DE 9-15	1
11	OVERLOAD	DE 2-5	1
12	HEATER COIL	DE 9-14	1
13	SWITCH	DE 5-8	2
14	SWITCH	DE 5-9	1
15	LAMP	DE 9-16	1
16	LAMP	DE 9-17	1
17	LAMP	DE 9-18	1
18	CIRCUIT BREAKER	DE 9-19	1
19	BOOT	DE 9-13	2
20			
21			
22			
23			
24			

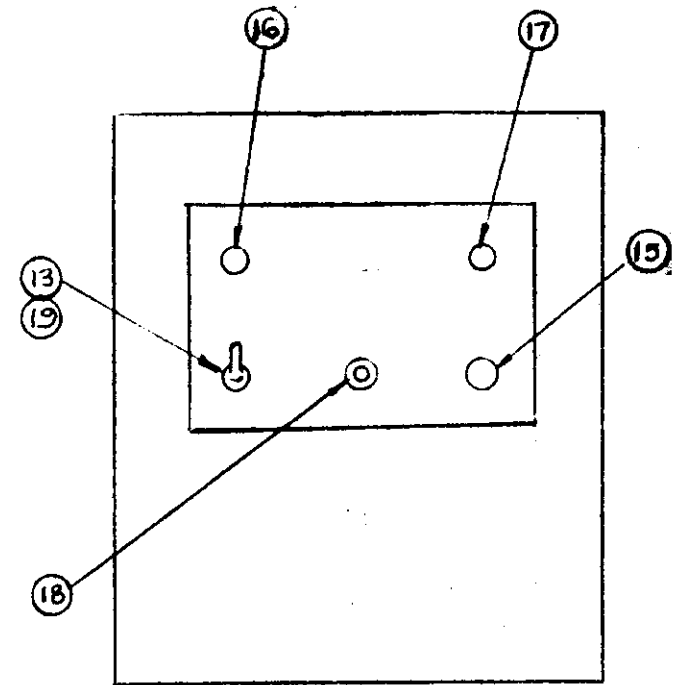
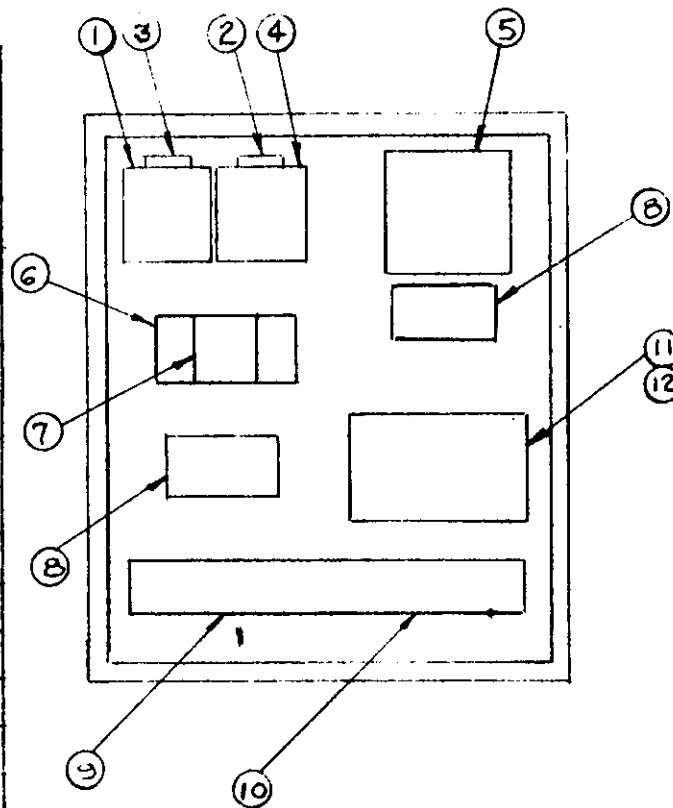

COVER REMOVED

PART No. FOR COMPLETE ASSY - 293-3

MACHINE COMMANDER 18			DWG. NO. SK 2406
TITLE ELECTRIC CONTROL BOX			PATT. NO.
MAT'L —	REQ. 1	SCALE —	DRWN. AP 5-10-79
INSINGER MACHINE CO. PHILA., PA. 19135			CHKD.
			APPD.

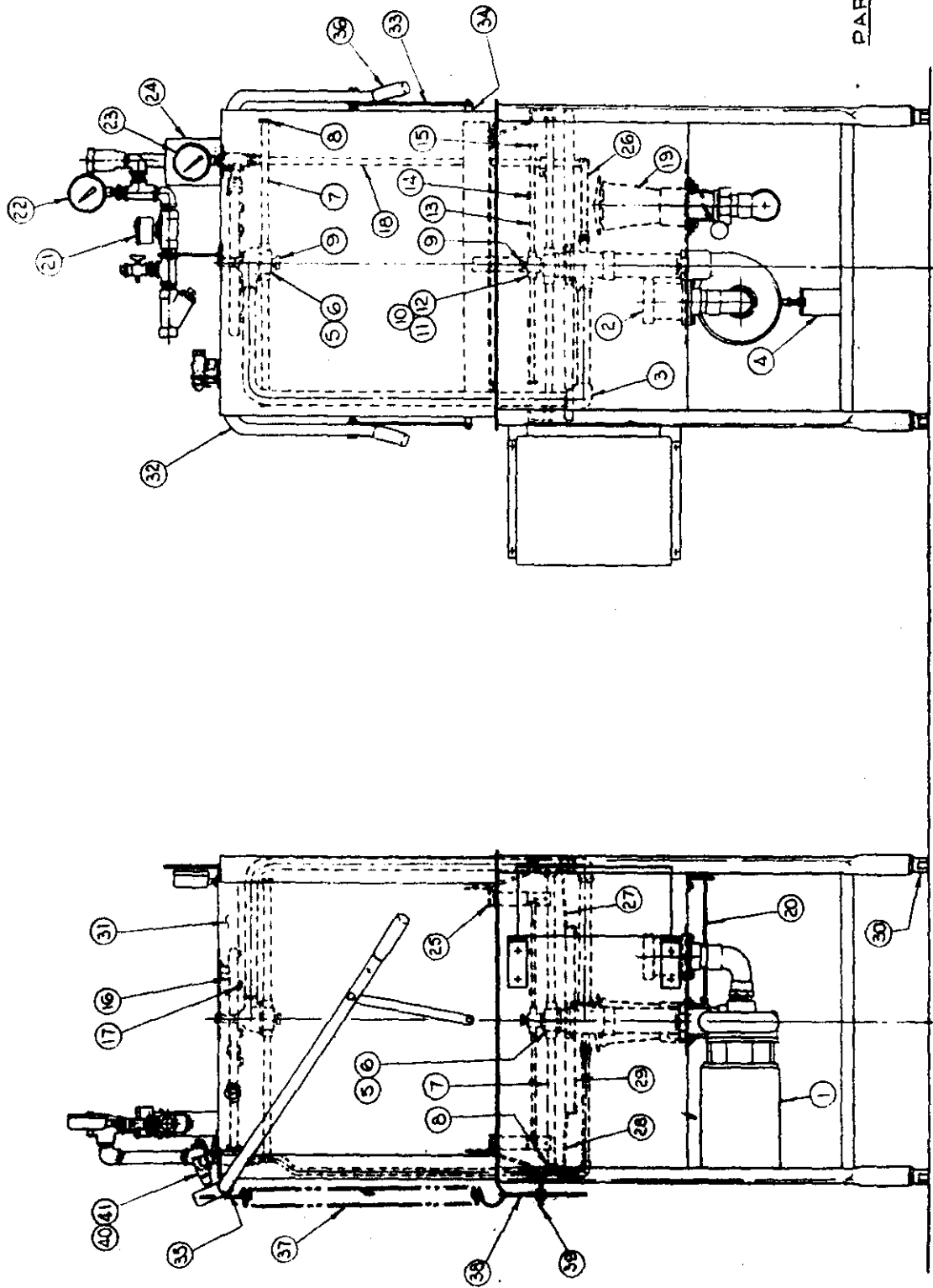

PARTS LIST - COMMANDER 18-2

SK-2629A

INSINGER MACHINE CO.  
PHILA. PA. 19136 (21B) 624-4800

CP 2-6-53  
PG. 1 OF 2

PARTS LIST - COMMANDER 18-2

<u>ITEM</u>	<u>PART NO.</u>	<u>DESCRIPTION</u>	<u>REQ.</u>
1	D-2465	Pump & Motor Ass'y. (1 HP)*	1
2	D2-541	Suction Strainer	1
3	1084-30A	Discharge Line Ass'y.	1
4	1084-60	Motor Support Angle	1
	1089-25	Spinner Ass'y. - Wash.	(2 Ref.)
5	1084-76	Spray Hub-Wash	2
6	952-27	Bushing	2
7	1089-23	Spray Pipes	4
8	D2-554-2	Plug 3/4-10 UNC - 2A	4
9	952-28A	Locking Screw	2
	1089-26	Spinner Ass'y.- Rinse	(1 Ref.)
10	372-52	Spray Hub-Rinse	1
11	1084-35	Bushing - Upper	1
12	1084-36	Bushing - Lower	1
13	1089-24	Spray Pipes - Rinse	1 ea.
14	D-2286A	Spray Nozzles - Rinse	4
15	D2-554-1	Plug 9/16 - 12 UNC - 2 A	2
16	971-49	Spray Coil - Final Rinse	1
17	D-2021	Spray Nozzle - Final Rinse	5
18	1084-124E	Final Rinse Piping Ass'y.(Vertical)	1
19	954-1A	Drain Ass'y.	1
20	925-52	Drain Handle Ass'y.	1
21	D-2397	Solenoid Valve	1
22	D-2495	Temp. Gauge - Final Rinse	1
23	D-2390	Temperature Gauge	1
24	D2-754A	Guard Temp. Gauge	1
25	1084-14A	Track Ass'y.	2
26	1084-124D	Final Rinse Piping Ass'y. (Horizontal)	1
27	1084-11A	Tray Spacer - Front	1
28	1084-42A	Tray Spacer - Rear	1
29	1084-12	Scrap Screen	1
30	D-2430	Bullet Foot	4
31	1084-6	Door	2
32	1084-25	Door Arm	1
33	1084-38	Link - Door Arm	2
34	957-26	Spacer - Door Arm Link	2
35	1084-39	Pivot Bracket - Door ARM	2
36	D-2245	Grip-Door Handle	2
37	SK-2294A	Spring	2
38	957-27	Spring Extention - Lower	2
39	1084-17	Spring Bracket - Lower	1
40	1084-43	Bracket - Microswitch	1
41	D-2215 A	Microswitch	1

\* Specify Voltage

*SK-2629A*

<b>INSINGER MACHINE CO.</b> PHILA. PA. 19135 (215) 624-4800
--

*RAF 2.6.85*

*PG. 2 OF 2*

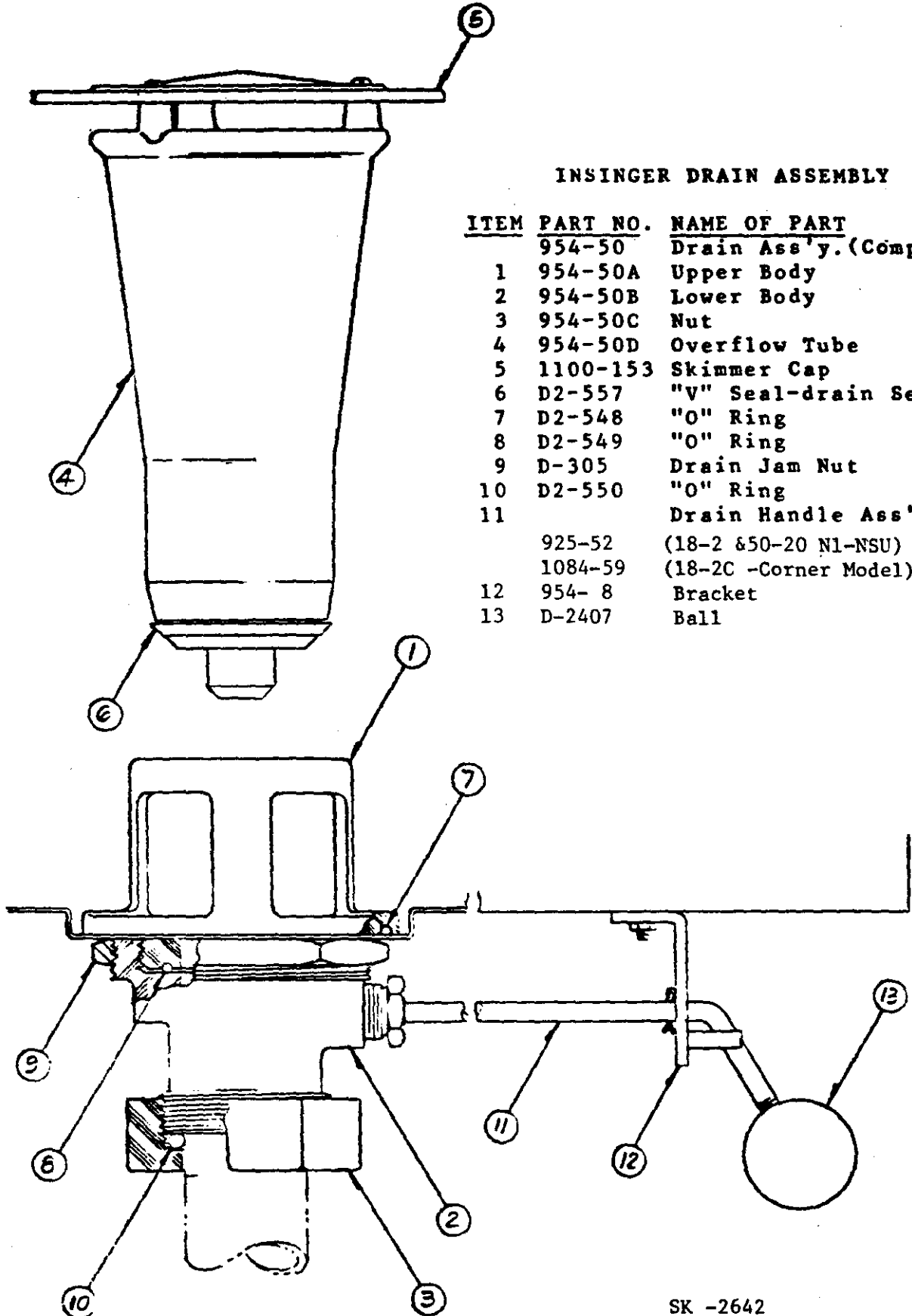

**INSINGER DRAIN ASSEMBLY**

ITEM	PART NO.	NAME OF PART	RE
	954-50	Drain Ass'y. (Comp)	
1	954-50A	Upper Body	1
2	954-50B	Lower Body	1
3	954-50C	Nut	1
4	954-50D	Overflow Tube	1
5	1100-153	Skimmer Cap	1
6	D2-557	"V" Seal-drain Seat	1
7	D2-548	"O" Ring	1
8	D2-549	"O" Ring	1
9	D-305	Drain Jam Nut	1
10	D2-550	"O" Ring	1
11		Drain Handle Ass'y.	1
	925-52	(18-2 & 50-20 N1-NSU)	
	1084-59	(18-2C -Corner Model)	
12	954- 8	Bracket	1
13	D-2407	Ball	1

SK -2642

**INSINGER MACHINE CO.**  
**PHILA., PA. 19135**

RAF 5.2.84

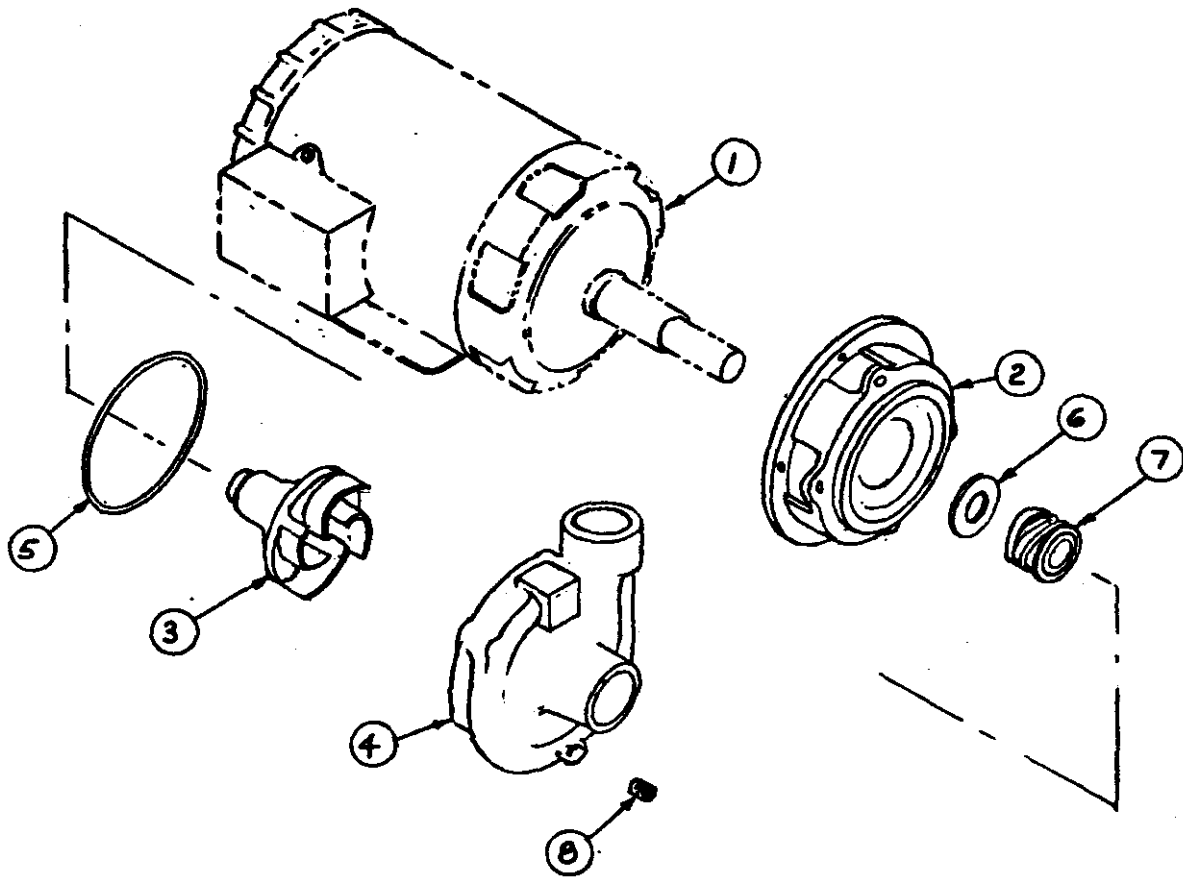

PARTS LIST - 1 HP PUMP

ITEM	PART NO.	PART NAME	REQ'D
1	*	Motor	1
2	D-431	Adapter	1
3	D-436	Impeller 3 7/8	1
4	D-434	Casing	1
5	D2-532	"O" Ring	1
6	D2-533	Flinger	1
7	D2-534	Seal Assembly	1
8		Drain Plug 1/4 IPS	1

Complete Pump & Motor - Part No.

D-2465-1 - SINGLE PHASE

D-2465-3 - THREE PHASE

\*Specify Voltage

**INSINGER MACHINE CO.**  
PHILA. PA. 19135

SK-2462

B.F. 12.19.80

**OPERATION:**

This unit is designed to fill & automatically maintain the desired water level. If unit is equipped with two (2) switches & one (1) thermostat, it will also control the water temperature automatically. To operate, simply turn control switch "ON". Turn switch "OFF" before draining tank.

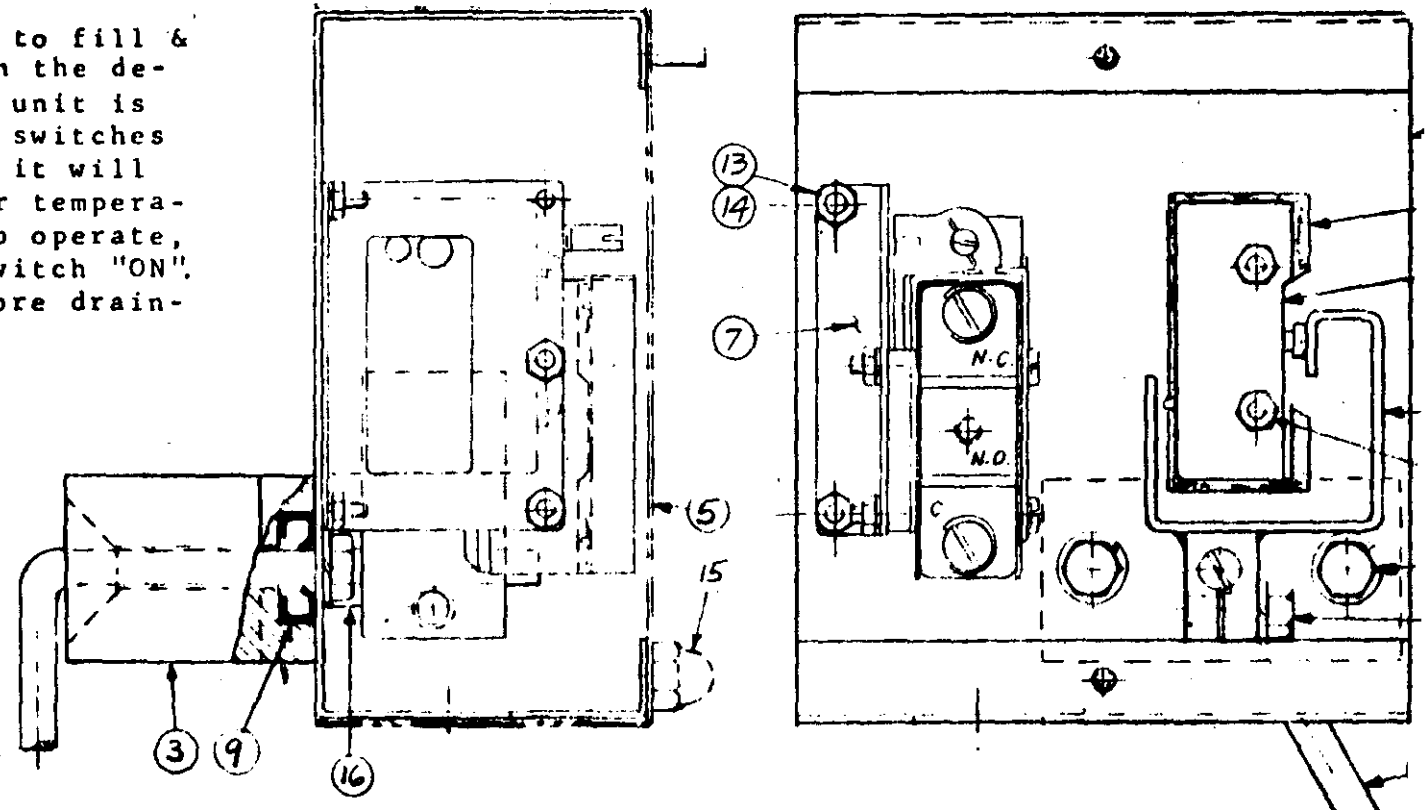

ITEM	Part No.	NAME	Req.
1	956-2	Back Plate	1
2	956-4	Contact Arm Weldm.	1
3	956-6	Float Bearing	1
4	956-7	Float Arm	1
5	956-8	Cover	1
6	519-8	Switch Insulator	2
7	DE9-32	Thermostat	1
8	D-2405	Float	1
9	D2-529	Seal	1
10	DE5-7	Microswitch	2
11		Hex HD Screw 1/4-20 S/S	3
12		Lockwasher Split 1/4 S/S	3
13		Hex Nut #6-32 S/S	2
14		Lockwasher Split #6 S/S	2
15		Acorn Nut #10-32	2

**MAINTENANCE:**

Periodically inspect moving parts & sensing bulb for lime deposit. Remove deposits with de-liming solution. NOTE: Thermostat and float level are set at factory & should not require adjustment.

**FLOAT SWITCH ASSEMBLY**  
**INSINGER MACHINE CO.**  
 PHILA., PA. 19135

**SK-2304A**

RAC 2-25-82

**ELECTRIC IMMERSION HEATER**  
**INSTRUCTIONS FOR INSTALLATION AND MAINTENANCE**

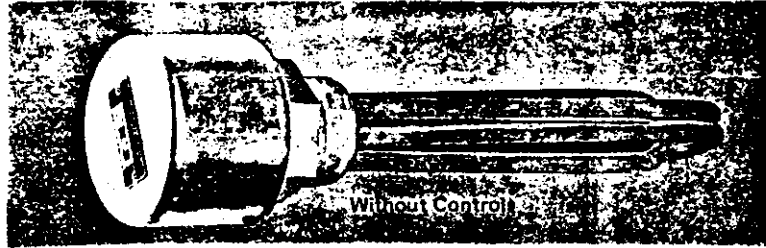

Heaters are carefully made and inspected to insure maximum life and efficiency. Follow these instructions for correct installation and operation.

INSTALLATION

Care must be taken to insure complete immersion of the heated length of the heater at all times. The heated surface should never be in contact with any sludge.

In the case of flange and pipe-thread type heaters where a gasket seal is necessary the gasket surface should be clean and dry before the heater is seated. The terminals must be protected at all times from moisture or vapor; in hazardous locations, explosion-resistant covers should be used.

The heaters should be inspected periodically for coatings and corrosion, and cleaned if necessary.

GENERAL INFORMATION

Immersion heaters with 115/120 volt or 230/240 volt elements can be connected in series for higher voltage operation except where uneven wattage is supplied on the respective elements.

Never bend the heating elements. If bending is necessary, check the factory.

INSINGER MACHINE CO.  
6245 State Rd.  
Phila., Pa. 19135

# ELECTRICAL INSTALLATION INSTRUCTIONS FOR

## HATCO ELECTRIC BOOSTER WATER HEATERS

### GENERAL INSTRUCTIONS

Hatco Electric Booster Water Heaters are available for operation on almost all common AC power systems. Check the nameplate for the proper power supply. All electrical connections to elements, thermostats and magnetic contactors have been made at the factory. Supply wire size, fuse, breaker and disconnect recommendations are listed on a separate sheet.

### CONNECTION INSTRUCTIONS

#### IMPERIAL MODELS

6 KW - 18 KW, 120/208/240 VOLTS (WITHOUT LOW WATER CUT-OFF)

1. Remove two (2) screws underneath bottom edge of lip under front cover. Pull bottom of cover forward and downward.
2. Bring power leads from a properly sized fused disconnect switch or circuit breaker (See Fuse and Disconnect Chart) through one of the knockouts provided and connect to the terminal block.
3. CAUTION: DO NOT TURN ON CURRENT TO BOOSTER HEATER UNTIL THE TANK HAS BEEN FILLED AND ALL AIR HAS BEEN VENTED THROUGH THE DISHWASHER RINSE NOZZLES. THE HEATING ELEMENTS WILL BURN OUT IN SECONDS IF THEY ARE NOT COVERED WITH WATER.
4. Replace the front cover of the booster heater.

6 KW - 18 KW, 480 VOLTS, 24 KW - 58.5 KW, ALL VOLTAGES (WITHOUT LOW WATER CUT-OFF)

ALL SIZES AND VOLTAGES (WITH LOW WATER CUT-OFF)

1. Remove two (2) screws underneath bottom edge of lip under front cover. Pull bottom of cover forward and downward.
2. Remove the front panel of the control box inside the heater.
3. Bring power leads from a properly sized fused disconnect switch or circuit breaker (See Fuse and Disconnect Chart) through one of the knockouts provided and connected to the terminal block.

4. CAUTION: DO NOT TURN ON CURRENT TO BOOSTER HEATER UNTIL THE TANK HAS BEEN FILLED AND ALL AIR HAS BEEN VENTED THROUGH THE DISHWASHER RINSE NOZZLES. THE HEATING ELEMENTS WILL BURN OUT IN SECONDS IF THEY ARE NOT COVERED WITH WATER.
5. Replace the front panel of the control box and the front cover of the heater.

#### POWERMITE AND KITCHENEER

6 KW - 18 KW, 120/208/240 VOLTS (WITHOUT LOW WATER CUT-OFF)

1. Remove cover on small 4 x 4 handy box on side of booster heater.
2. Bring power leads from a properly sized fused disconnect switch or circuit breaker (See Fuse and Disconnect Chart) through one of the knockouts provided and connect to the wire pigtail in the handy box as shown on the wiring diagram provided. Insulate the wire joints properly and coil the wires back in the handy box.
3. CAUTION: DO NOT TURN ON CURRENT TO BOOSTER HEATER UNTIL THE TANK HAS BEEN FILLED AND ALL AIR HAS BEEN VENTED THROUGH THE DISHWASHER RINSE NOZZLES. THE HEATING ELEMENTS WILL BURN OUT IN SECONDS IF THEY ARE NOT COVERED WITH WATER.
4. Replace the cover on the handy box.

6 KW - 18 KW, 480 VOLTS, 24 KW - 58.5 KW, ALL VOLTAGES (WITHOUT LOW WATER CUT-OFF)

ALL SIZES AND VOLTAGES (WITH LOW WATER CUT-OFF)

1. Remove the large cover from the jacket by removing the six screws.
2. Bring power leads from a properly sized fused disconnect switch or circuit breaker (See Fuse and Disconnect Chart) through the hole provided in the jacket and connect to the terminal block.
3. CAUTION: DO NOT TURN ON CURRENT TO BOOSTER HEATER UNTIL THE TANK HAS BEEN FILLED AND ALL AIR HAS BEEN VENTED THROUGH THE DISHWASHER RINSE NOZZLES. THE HEATING ELEMENTS WILL BURN OUT IN SECONDS IF THEY ARE NOT COVERED WITH WATER.

4. Replace the large jacket cover and six screws.

### COMPACT

#### ALL MODELS, ALL VOLTAGES (WITH OR WITHOUT LOW WATER CUT-OFF)

1. Remove two (2) screws underneath bottom edge of lip under front cover. Pull bottom of cover forward and down.
2. Bring power leads from a properly sized fused disconnect switch or circuit breaker (See Fuse and Disconnect Chart) through a knockout provided in the base and connect to the terminal block.
3. CAUTION: DO NOT TURN ON CURRENT TO BOOSTER HEATER UNTIL THE TANK HAS BEEN FILLED AND ALL AIR HAS BEEN VENTED THROUGH THE DISHWASHER RINSE NOZZLES. THE HEATING ELEMENTS WILL BURN OUT IN SECONDS IF THEY ARE NOT COVERED WITH WATER.
4. Replace the front cover on the heater.

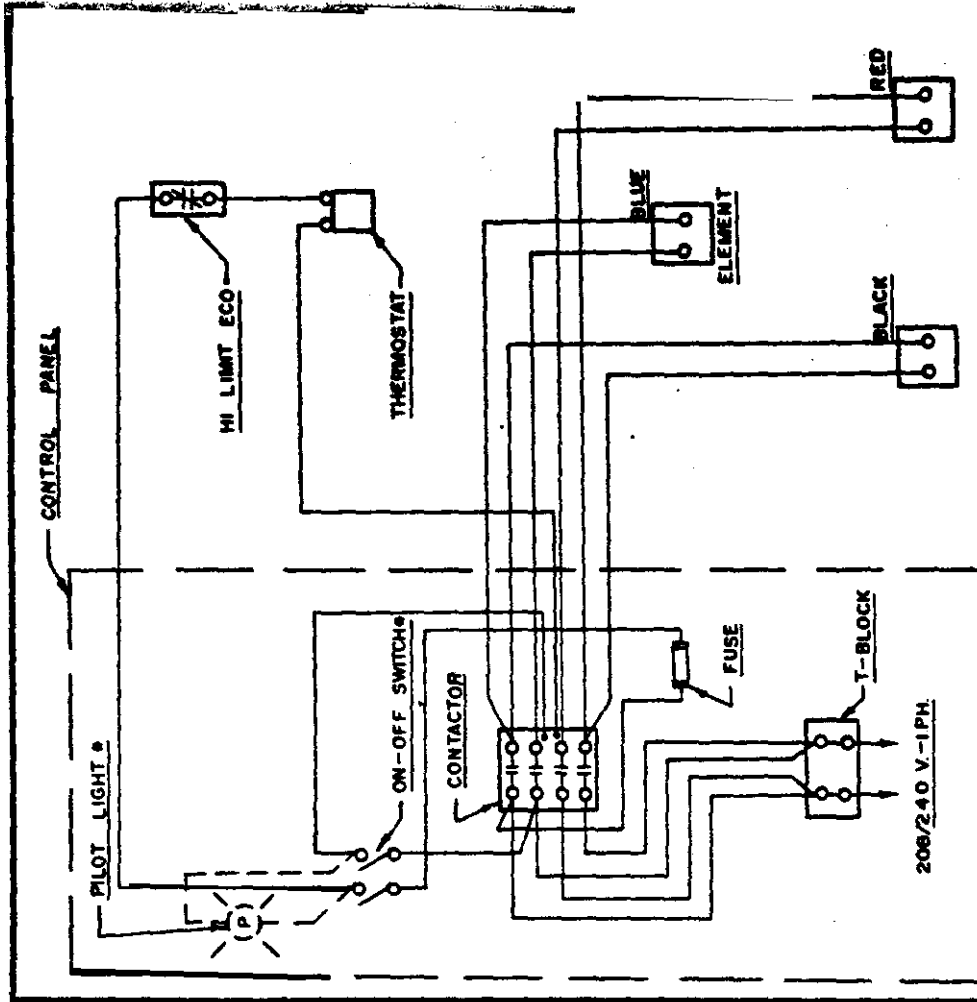

• CIRCUIT FOR LIGHT AND SWITCH WHEN SUPPLIED

THIS CIRCUIT IS NOT TO BE INTERFERED WITH BY THE CUSTOMER.	
<b>WIRING DIAGRAM FOR</b> <b>SMALL COMPACT</b> <b>0.5 KW - 208/240 V - 1 PH.</b>	
MATCO COMP., INCORPORATED D.G.S. 12-68	<b>HC 1-2228</b>

NO.	DESCRIPTION	PART NO.	QTY.
1	BOOSTER ASSEMBLY	C9-12	1
2	RELIEF VALVE	SUPL. W/BOOSTER	1
3	BALL VALVE 3/4 IPS	D-2340	1
4	CLOSE NIPPLE 3/4 IPS	D314A-ECL	2
5	BRACKET	DWG. 982-49	1
6	PRESS. REG. & STRAINER 3/4 IPS	D-2508	1
7	TEE 3/4 IPS	D320A-E1	1
8	REDUCER 3/4 MIP S x 1/4 FIP S	D322A-E2-B1	1
9	PIPE PLUG 1/4 IPS	D328A-B-A	1
10	ADAPTER 3/4 MIP S x 3/4 C	D317A-E2-E3	1
11	COPPER TUBING 3/4 CTS x 5 3/4" LG	D207A-B6-23	1
12	90° ELBOW 3/4 C	D316A-E3	3
13	COPPER TUBING 3/4 CTS x 7 1/4" LG	D207A-B6-29	1
14	90° ELBOW 3/4 FIP S x 3/4 C	D316A-E1-E3	2
15	90° STREET ELL 3/4 IPS	D316A-E1-E2	2
16	UNION 3/4 C	D318A-E3	1
17	COPPER TUBING 3/4 CTS x 13 1/4" LG.	D207A-B6-53	1
18	COPPER TUBING 3/4 CTS x 38 3/4" LG	D207A-B6-155	1
19	COPPER TUBING 3/4 CTS x 4 3/4" LG.	D207A-B6-19	1
20	90° UNION ELL 3/4 MIP S x 3/4 C	D319A-E2-E1	1
21	COPPER TUBING 3/4 CTS x 8" LG.	D207A-B6-32	1

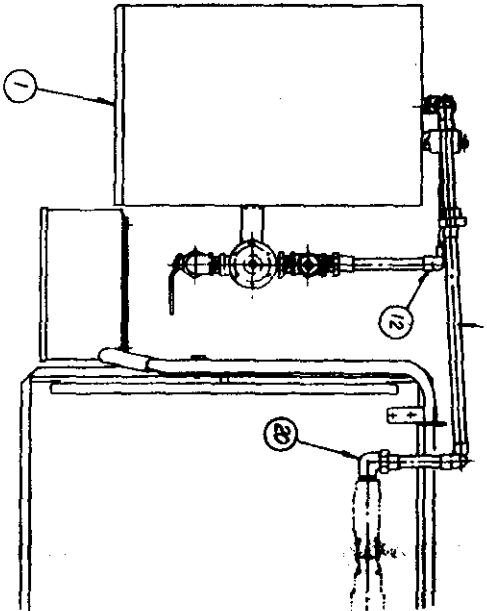
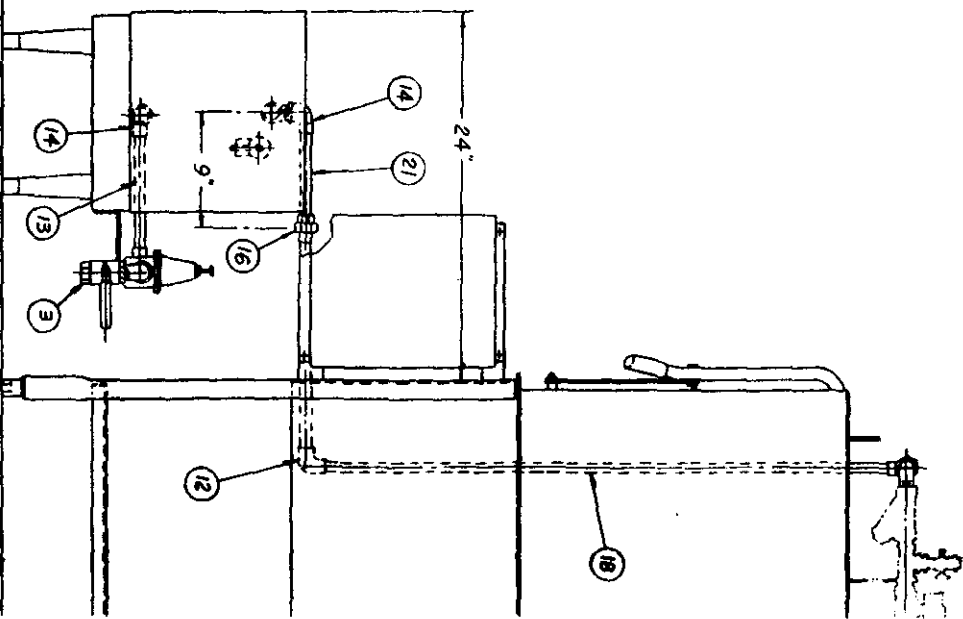
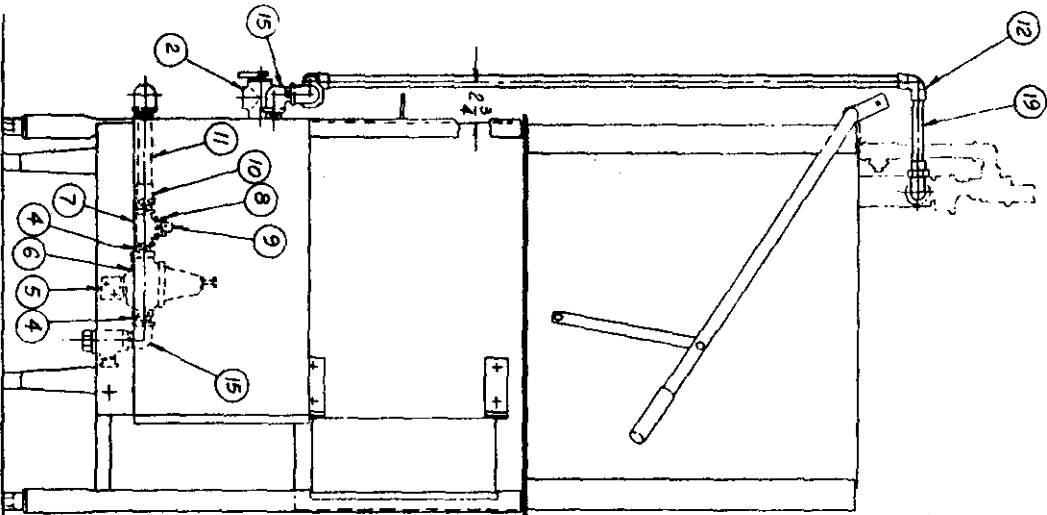

1084-73

▲ STRAIGHT UNION WAS 90° UNION ELBOW.  
 (ITEM #16), (17), (19) WAS (ITEM #18), (19),  
 WAS 90° UNION (ITEM #17) AND ADDED (ITEM #17).  
 DATE: 11.7.54

TOLERANCES		WHIT	PART NO.	DATE
FRACTIONS & 1/4"		<b>ELECT. BOOSTER</b>		
DECIMAL & 1/8"		<b>ASSEMBLY</b>		
ANGULAR & 1/2°		NOTED	REV. 1	1004-73
UNLESS OTHERWISE SPECIFIED		INSINGER MACHINE CO.		
		PHILA. PA. 19135 (215) 624-4000		
		SCALE 5/8	ISS. ON	1-4-50
			COR. 10-5	

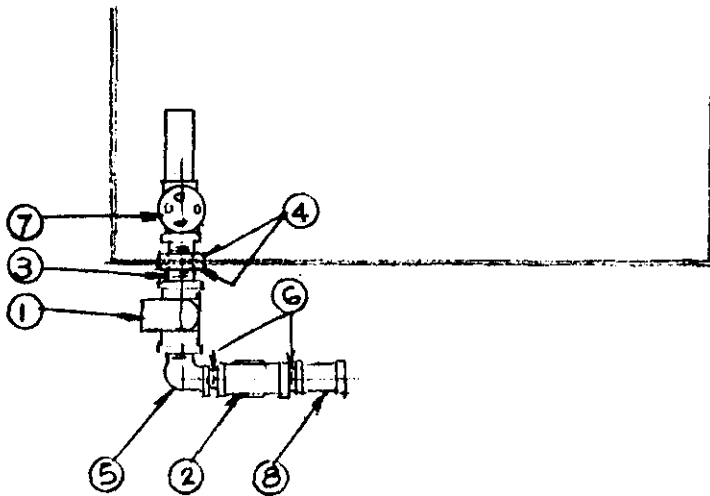

LIST OF PARTS			
NO.	PART NO.	NAME	REQ.
1	SOL. VALVE 1/2	D2418-24V	1
2	STRAINER 1/2	D2483A	1
3	NIPPLE-ALL THRU 2	D314A-D8AT	1
4	LOCKNUT 1/2	D326A-D1	2
5	ST. ELL 90° 1/2	D316A-D1-D2	1
6	NIPPLE CL. 1/2	D314A-D-CL	2
7	INJECTOR STEAM 1/2	D942	1
8	CHECK VALVE 1/2	D2458	1
9			
10			

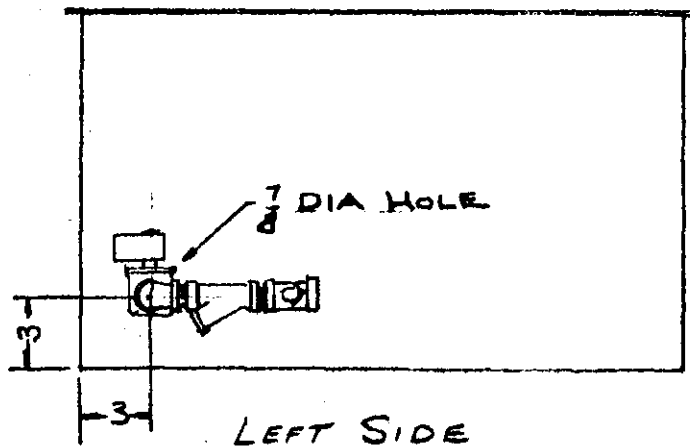

FRONT

TOLERANCES FRACTIONS ± 1/64 DECIMAL ± .005 ANGULAR ± 1/2° UNLESS OTHERWISE SPECIFIED	TITLE	TANK HEAT STEAM INJECTOR	PATT. NO.	DWG. NO.
	MATL	NOTED	REQ. 1	1084-4
	INSINGER MACHINE CO.		SCALE 1/8	USED ON
	PHILA., PA. 19135 (215) 624-4800		18-2	18-20
				2-27-24

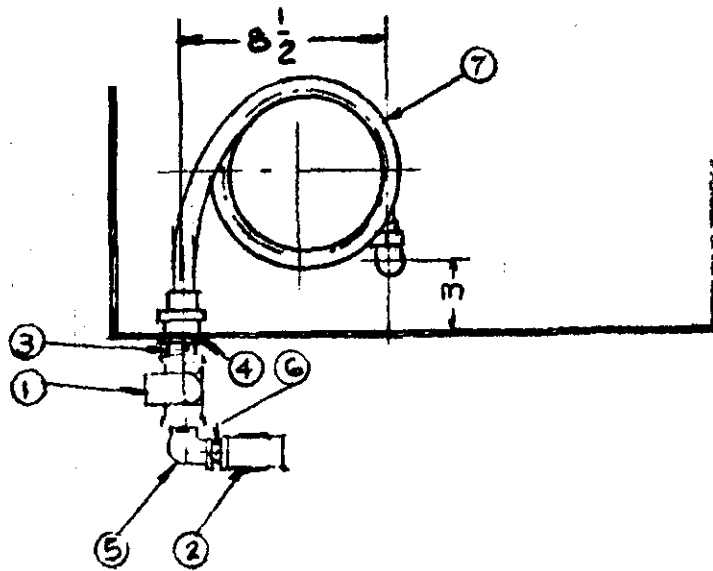

LIST OF PARTS			
NO.	PART NO	NAME	QTY
1	SOL. VALVE 1/2	D2418-24V	1
2	STRAINER 1/2	D2483A	1
3	NIPPLE ALTHD: 2	D314A-DBAT	1
4	LOCKNUT 1/2	D326A-D1	2
5	ST. ELL 90° 1/2	D316A-D1-D2	1
6	NIPPLE CL. 1/2	D314A-D-CL	1
7	STEAM COIL	1084-53 or 1084-53A	1
8	NIPPLE LOE 1/2 x 1 1/2	D314A-D6 LOE	1
9	COND. TRAP 3/8	D-2102	1
10	REDUCER 1/2 x 3/8	D322A-D1-C1	1
11	NIPPLE, CL. 3/8	D314A-D-CL	1
12	ST. ELL 90° 3/8	D316A-C1-C2	1

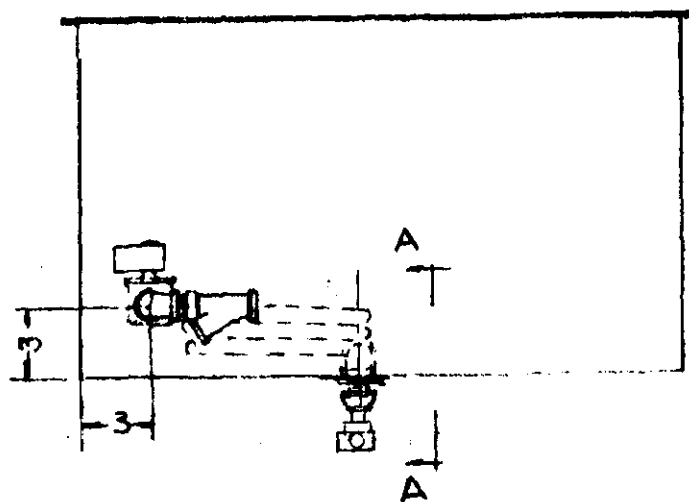

FRONT

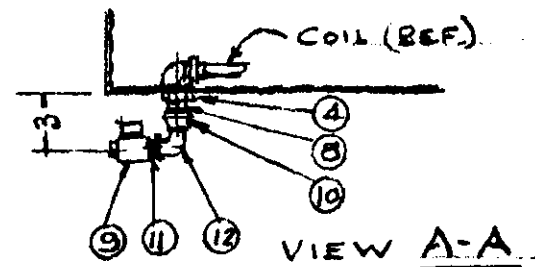

TOLERANCES FRACTIONS ± 1/64 DECIMAL ± .005 ANGULAR ± 1/2° UNLESS OTHERWISE SPECIFIED	TITLE TANK HEAT STEAM COILS	PART. NO. NO. 1	DWG. NO. 1084-53
	MATL. -	SCALE 1/8	USED ON 18-2 18-2C
INSINGER MACHINE CO. PHILA. PA. 19135 (215) 624-4800		2-27-54	

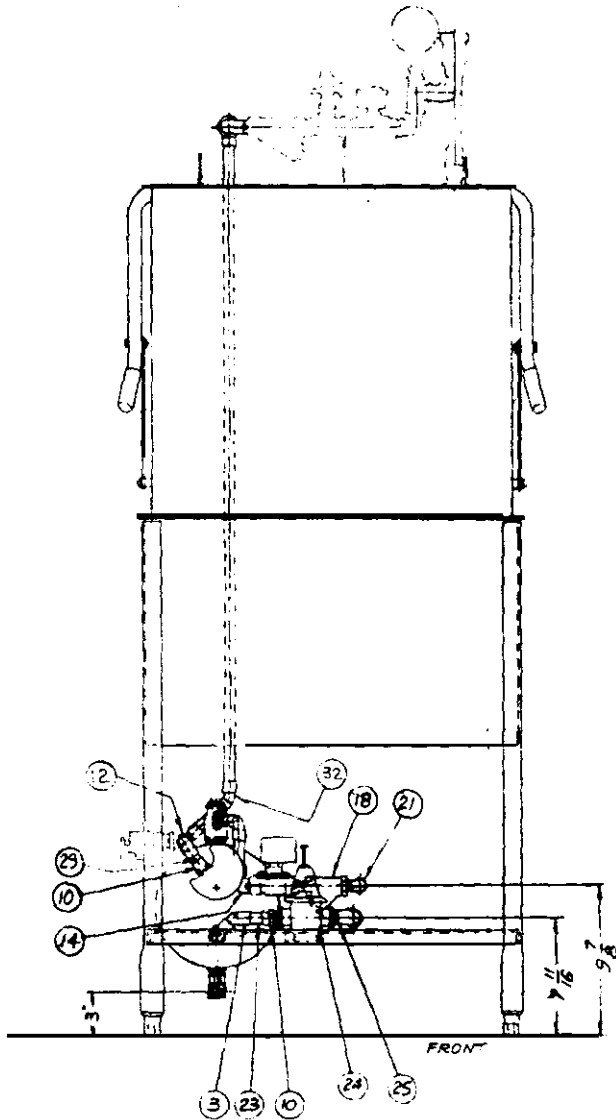
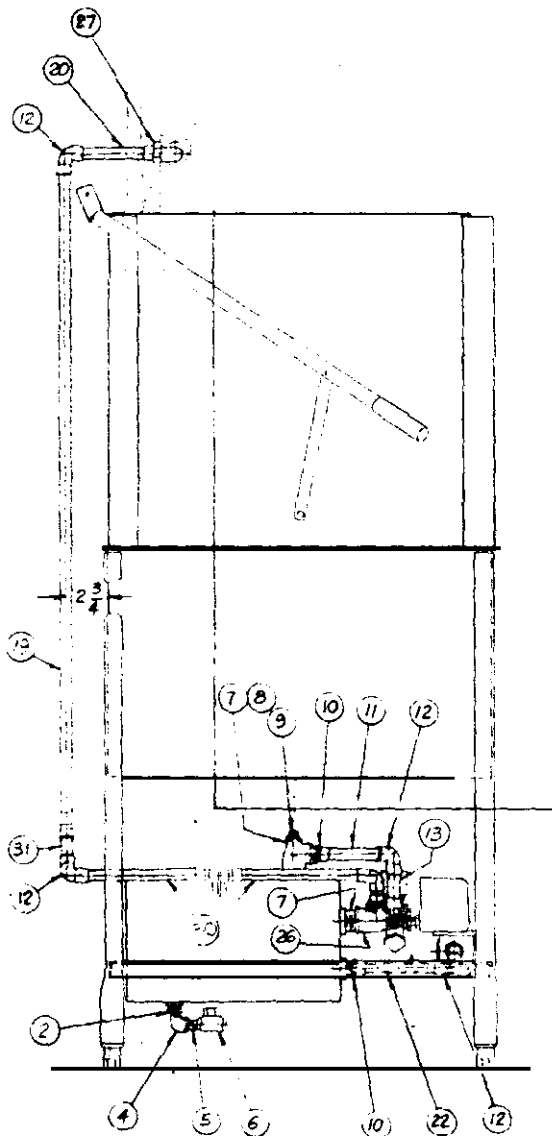
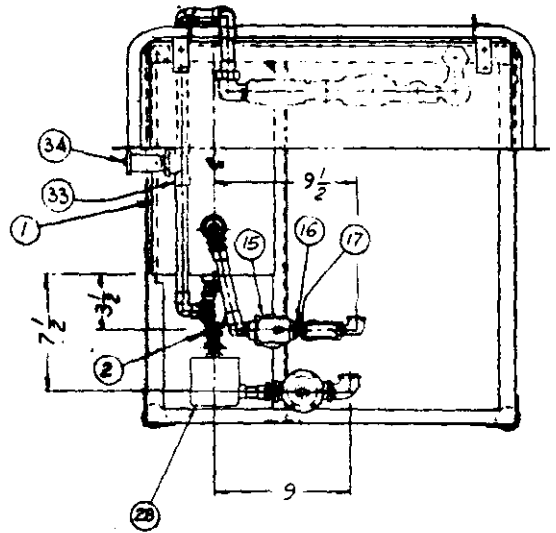

A  $8\frac{3}{4}$  WAS  $18\frac{7}{8}$ , QTY (2) WAS (1)  
 (ITEM #30), 42 WAS 40 (ITEM #19),  
 45° ELBOW WAS 45° STREET  
 ELBOW (ITEM #32). CB 5-29-86

B 40 WAS  $42\frac{1}{4}$  (ITEM #19), STREET ELL  
 WAS O.A.C (ITEM #32), AND ADDED  
 ITEM #33 & 34 RA 11.16.84

C D2490 WAS D2397 (ITEM #15), AND  
 ADDED NOTE RA 7.31.84

2-20-84  
 29-7-80

SUPERSEDES SAME NO. DATED 4.9.84

TOLERANCES FRACTIONS ± 1/64 DECIMAL ± .005 ANGULAR ± 1/2° UNLESS OTHERWISE SPECIFIED	TITLE <b>STEAM BOOSTER          ASSEMBLY</b>	PART NO. REG 1	DRAWING NO. 1004-87
	DATE SEE PG. 2 OF 2	SCALE 1/8" = 1"	USED IN QDR 18-2
	INSINGER MACHINE CO. PHILA. PA. 19135 (215) 624-4800		DATE 7.2.84
	PG 1 OF 2		

NO.	DESCRIPTION	PART NO.	REQ.
1	INSINGER STEAM BOOSTER (14")	D-2526	1
2	HEX REDUCER 3/4 MIP S x 3/8 FIP S	D322A-E2-C1	2
3	45° STREET ELBOW 3/4 C	D316A-E3-E4	1
4	90° STREET ELBOW 3/8 IPS	D316A-C1-C2	1
5	CLOSE NIPPLE 3/8 IPS	D314A-CCL	1
6	STEAM TRAP 3/8 IPS	D-2102	1
7	CLOSE NIPPLE 1" IPS	D314A-FCL	2
8	TEE 1" IPS x 1/2 IPS x 3/4 IPS	D320A-F1E1E1	1
9	PIPE PLUG 1/2 IPS	D328A-D-A	1
10	ADAPTER 3/4 MIP S x 3/4 C	D316A-E2-E3	4
11	COPPER TUBING 3/4 CTS x 4 3/8" LG.	D207A-B6-18	1
12	90° ELBOW 3/4 C	D316A-E2	5
13	COPPER TUBING 3/4 CTS x 3" LG.	D207A-B6-12	1
14	90° ELBOW 3/4 MIP S x 3/4 C	D316A-E2-E3	1
15	SOLENOID VALVE (STEAM) 3/4 IPS	D-2490	1
16	FLUSH REDUCER 3/4 MIP S x 1/2 FIP S	D328A-E2-D1	1
17	CLOSE NIPPLE 1/2 IPS	D314A-DCL	1
18	"Y" STRAINER 1/2 IPS	D-2483A	1
19	COPPER TUBING 3/4 CTS x 10" LG.	D207A-B6-16B	1
20	COPPER TUBING 3/4 CTS x 4 3/4" LG.	D207A-B6-19	1
21	90° STREET ELL 1/2 IPS	D316A-D1-D2	1
22	COPPER TUBING 3/4 CTS x 6 3/16" LG.	D207A-B6-25	1
23	COPPER TUBING 3/4 CTS x 2 1/2" LG.	D207A-B6-10	1
24	PRESS. REGULATOR & STRAINER 3/4 IPS	D-250B	1
25	90° STREET ELL 3/4 IPS	D316A-D1-D2	1
26	TEE 1" IPS x 3/4 IPS x 3/4 IPS	D320A-F1E1E1	1
27	90° UNION ELL 3/4 MIP S x 3/4 C	D319A-E2-E3	1
28	THERMOSTAT 3/8 IPS	D-2396	1
29	COPPER TUBING 3/4 CTS x 1 1/2" LG.	D207A-B6-6	1
30	COPPER TUBING 3/4 CTS x 1" LG.	D207A-B6-35	2
31	COPPER TUBING 3/4 CTS x 3 1/4" LG.	D207A-B6-13	1
32	45° ELBOW 3/4 C	D315A-E3	1
33	TEE 3/4 C x 3/4 C x 3/4 FIP S	D320A-E3E3E1	1
34	PRESSURE RELIEF VALVE 3/4 IPS	D-2507	1

NOTE:

1. USE D2452 (120-240V) IN PLACE OF D2490 (24V) WHEN SPECIFIED. (ITEM #15)

1084-67  
09 20 52

SUPERSEDES SAME NO. DATED 4.9.84

TOLERANCES	TITLE	REV. NO.	DATE
FRACTIONS ± 1/64	STEAM BOOSTER ASSEMBLY	1084-67	
DECIMAL ± .005	NOTE	SCALE	CDR 18-2
ANGULAR ± 1/2°	INSINGER MACHINE CO.		7.2.84
UNLESS OTHERWISE SPECIFIED	PHILA. PA. 19135 (215) 624-4000		



Insinger Machine Company  
6245 State Road  
Philadelphia, PA 19135-2996  
800-344-4802  
Fax: 215-624-6966  
[www.insingermachine.com](http://www.insingermachine.com)