



Ordering Parts

- Order by **part** number, not by **code** number
- Include information from nameplate specification (see figures at right)
- Complete model number (ex: WX-8)
- Complete serial number (ex: XM0000000 - thru September 2003)

Order parts from:

- (USA)
InSinkErator
4700 - 21st St.
Racine, WI 53406
- (Within the USA)
Foodservice and Tech Support
800.845.8345
- (Outside the USA)
Foodservice and Tech Support
262.554.5432

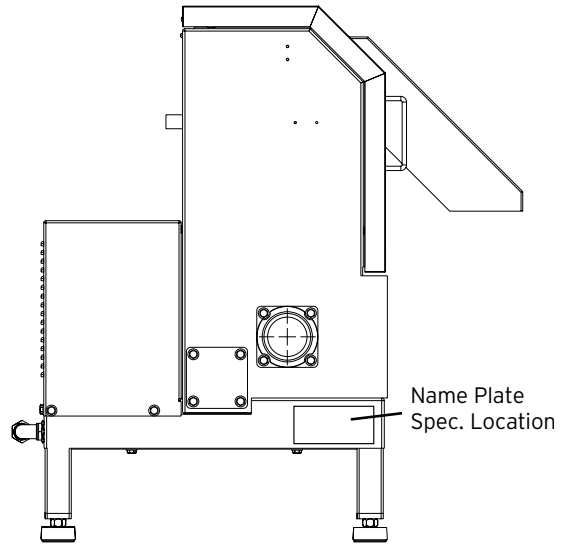

		SERIAL NUMBER: XXXXXXXXXXXX	
FOOD WASTE PULPER MODEL: WX-8 <small>PART NUMBER 14492B</small>			
VOLTS: 208/230V		AMPS: 2.5/2.0A	
1/2 HP	3 PH	60 HZ	1725 RPM
FOR SERVICE INFO, CALL 1-800-845-8345			
U.S. Pat. No. 7.137.503		14534B	

Unit Specifications and Identification

SERIES 1		
MODEL #	SPECIFICATION	SERIAL # RANGE
WX-1	115V / 1Phase	TD0000000 - XM0000000 0310XXXXXXXX - 0704XXXXXXXX
WX-2	208-230V / 3 Phase	
WX-3	200V 50/60 / 3 Phase	
WX-4	460V / 3 Phase	
WX-5	208-230V / 1Phase	

SERIES 2		
MODEL #	SPECIFICATION	SERIAL # RANGE
WX-8	208-230V / 3 Phase	0705XXXXXXXX - Higher
WX-9	460V / 3 Phase	

Note: Physical differences exist in the numerous service parts between the models in Series 1 and Series 2 - no substitutions between series should be carried out unless otherwise specified in the parts tables.

Plumbing

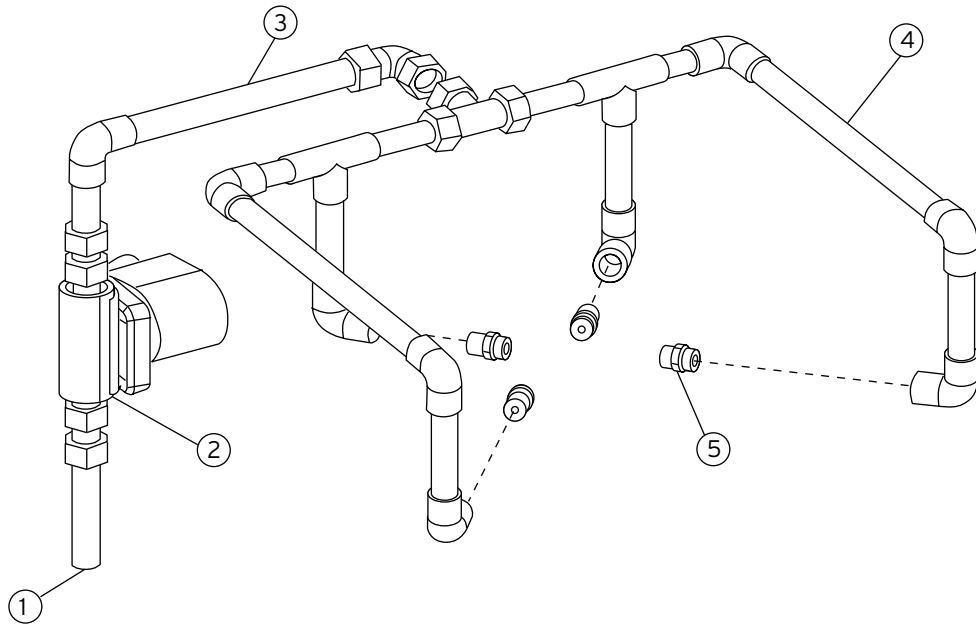

REPAIRS - WX-1 THRU WX-5

CODE #	DESCRIPTION	QTY	PART #
1	Water Inlet Tube	1	14263
2	Solenoid Valve - WX	1	14264
3	Tubing Assembly - Water Transfer	1	14265
4	Tubing Assembly - Spray Nozzle	1	14266
5	Spray Nozzle	4	14071

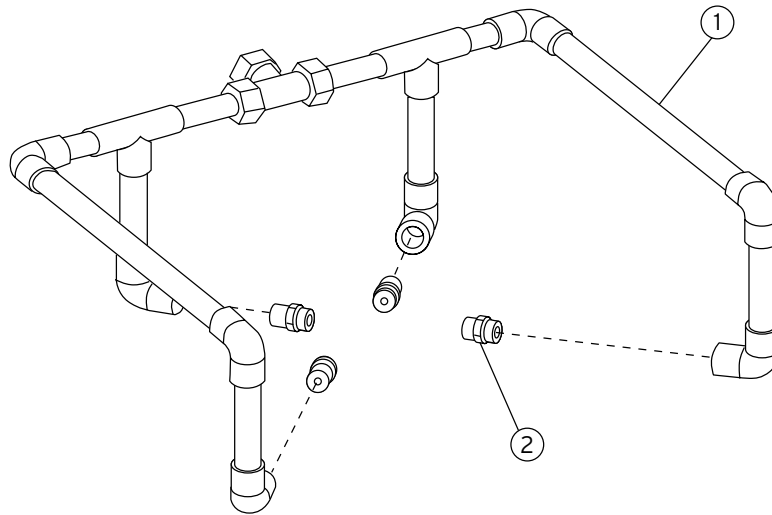

REPAIRS - WX-8 AND WX-9

CODE #	DESCRIPTION	QTY	PART #
1	Tube Assembly (Includes 14683)	1	14682
2	Spray Nozzle	4	14683

Cabinet

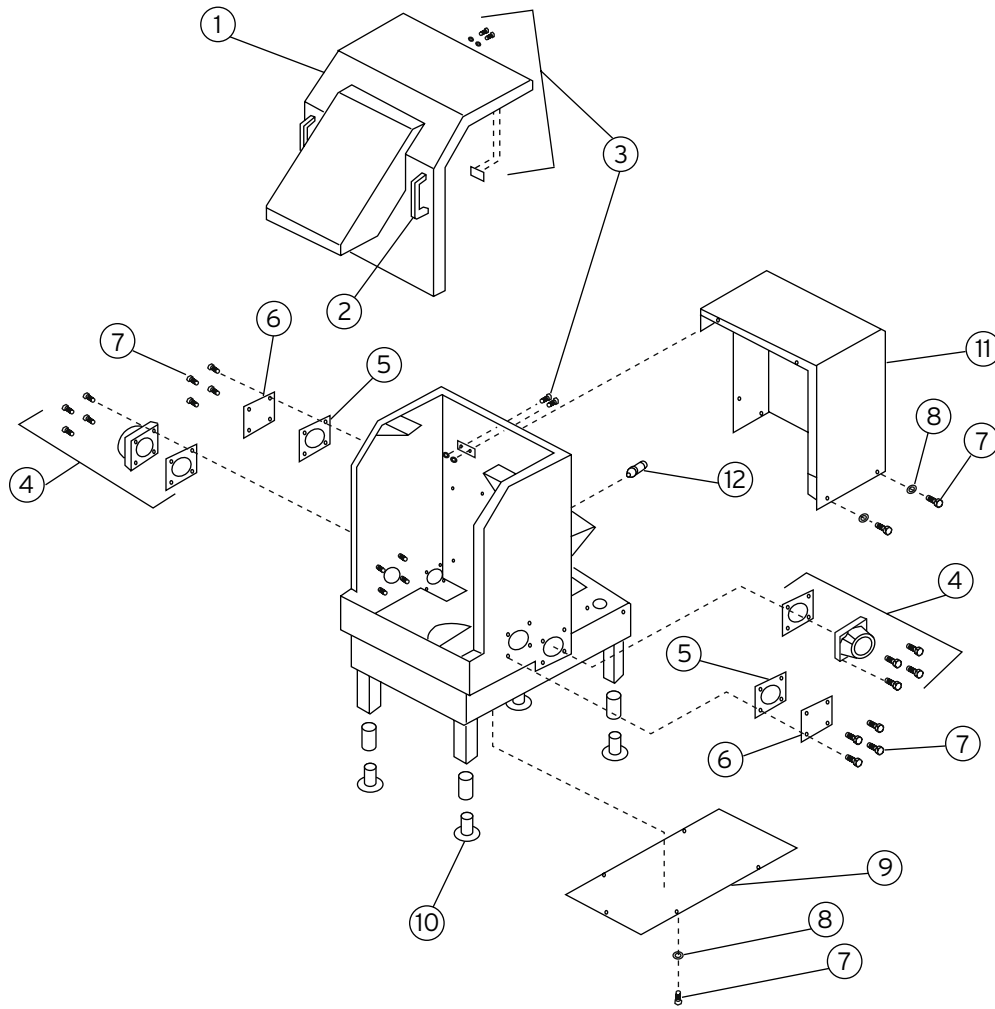

CODE #	DESCRIPTION	QTY	WX-1 TO WX-5 SERIES 1 PART #	WX-8 AND WX-9 SERIES 2 PART #
1	Discharge Chute	1	14251	14678
2	Handle, Discharge Chute	2	14252	N/A
3	Interlock Assembly	1	14258	14668
4	Inlet/Outlet Kit	1	14256	14679
5	Inlet/Outlet Gasket	1	14255	14681
6	Inlet/Outlet Cap	1	14254	14680
7	Bolt 1/4-20 x 1/2 SS	1	N/A	14698
8	Washer	1	N/A	
9	Belt, Cover WX	1	14260	14677
10	Foot - Adjustment	1	14259	14675
11	Motor Cover	1	14261	14676
12	Strain Relief	1	14262	14697

Cabinet

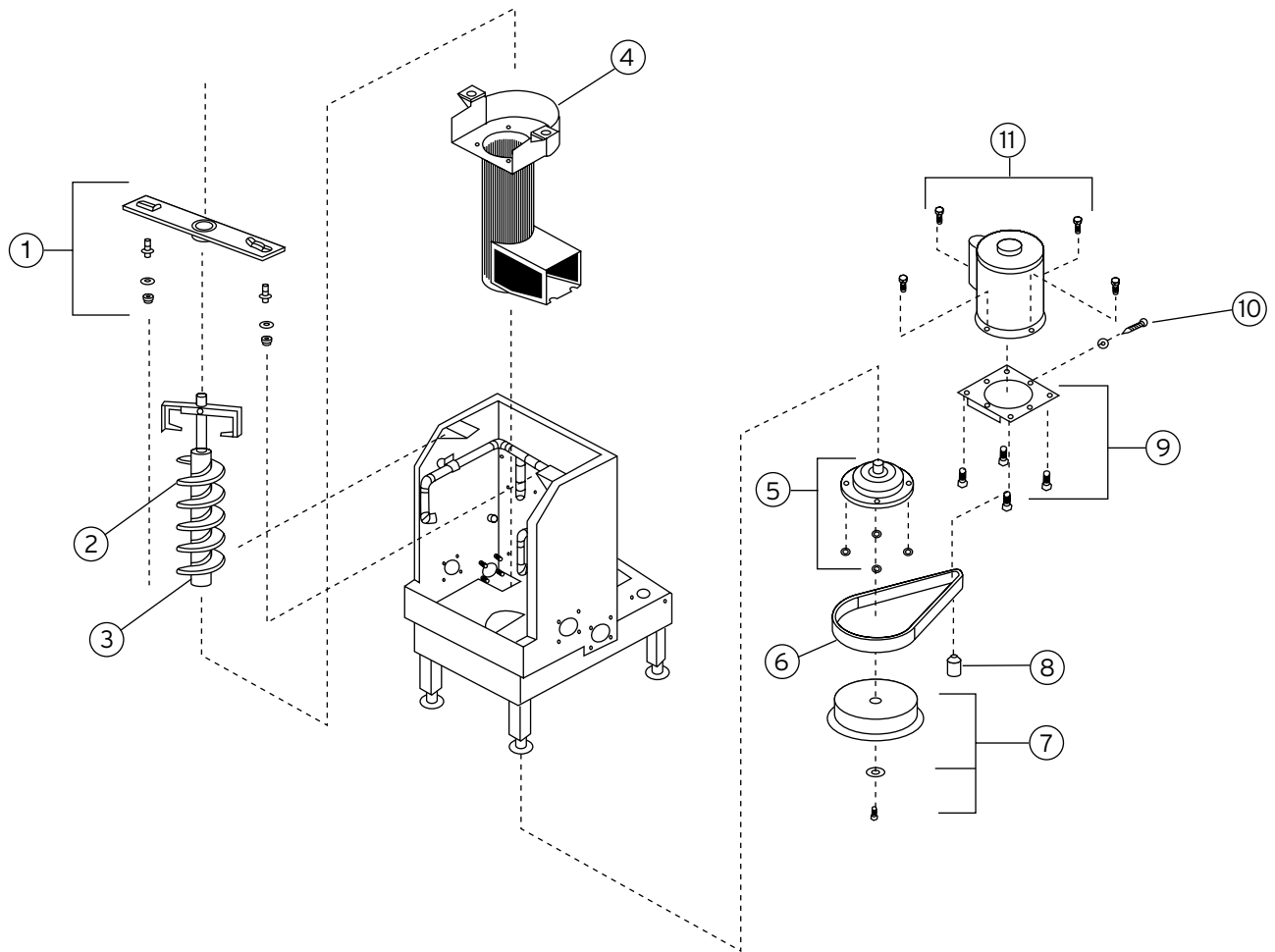

CODE #	DESCRIPTION	QTY	WX-1 TO WX-5 SERIES 1 PART #	WX-8 AND WX-9 SERIES 2 PART #
1	Bearing Bracket	1		14655
2	Auger Brush	1	N/A	14426
3	Auger	1		14401
4	Auger Screen	1	14359*	14665
5	Auger Drive Assembly	1	14244	14671
6	Auger Belt	1		14672
7	Auger Pulley	1	14246	14674
8	Motor Pulley	1	N/A	14673
9a	Motor Bracket - 1 Phase	1	14249	N/A
9b	Motor Bracket - 3 Phase	1	14249A	N/A
10	Tension Screw	1	14248	N/A
11a	Motor - 115/208-230V / 1 Phase	1	14247	N/A
11b	Motor - 208-230/460V / 3 Phase	1	14247A	14666

Electrical Controls

The primary difference between a Series 1 and a Series 2 WX is the location of the electrical controls specific to the pulper that operates the auger, controls the hot water spray cycle and protects the WX from becoming overloaded should the WX jam during its operation. In the original Series 1 design, a standard CC-101K control and later, the WX-101 were used to merely start and stop the system, and provide control for the cold water in the system. With the change to the Series 2 in May of 2007, the WX motor contactor, hot water spray timer and WX overload were relocated from inside the motor compartment on the back of the WX machine, to a more convenient location inside of the control center (WX-101A) itself. Servicing the controls should be referenced using the following tables (see separate spare parts sheet(s) for servicing CC-101K, WX-101 and WX-101A Series Control Centers).

SERIES 1

MODEL #	SPECIFICATION	CONTROL CENTER
WX-1	115V / 1 Phase	CC-101K-1 or WX-101-1
WX-2	208-230V / 3 Phase	CC-101K-3 or WX-101-3
WX-3	200V 50/60 / 3 Phase (Export)	CC-101K-3 or WX-101-3
WX-4	460V / 3 Phase	CC-101K-4 or WX-101-4
WX-5	208-230V / 1 Phase	CC-101K-2 or WX-101-2

REPAIRS - WX-1 THRU WX-5

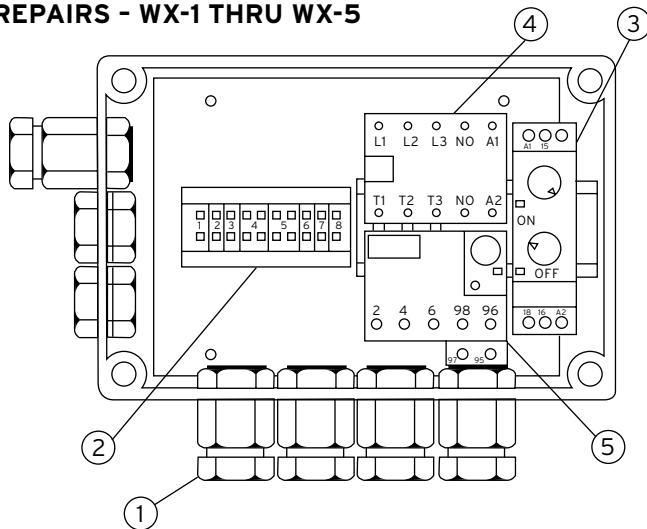

CODE #	DESCRIPTION	QTY	PART #
1	Strain Relief	5	14262
2	Terminal Block	1	14267
3	Hot Water Spray Timer	1	14268
4	Contactor	1	14113
5	Overload - Adj 208-230V	1	14106
	Overload - Adj 460V	1	14106A
	Overload - Adj 115 V	1	14106B

SERIES 2

MODEL #	SPECIFICATION	CONTROL CENTER
WX-8	208-230V / 3 Phase	WX-101A-3
WX-9	460V / 3 Phase	WX-101A-4

REPAIRS - WX-6 THRU WX-9

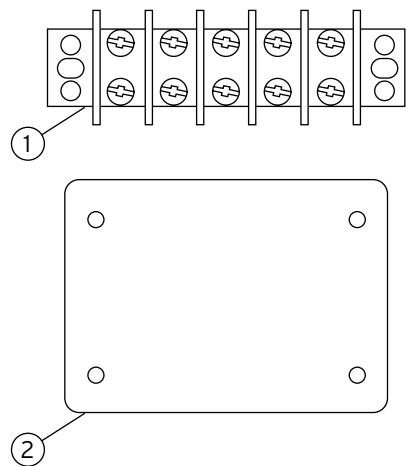

CODE #	DESCRIPTION	QTY	PART #
1	Terminal Block	1	14670
2	Terminal Block Cover	1	14669
3	Terminal Cover Gasket	1	14700

Note: Items #3-5 for Series 2 machines are located in WX-101A Control Center. See WX-101A parts sheet #1 F350-07F-45-10 REV 06/07 for details.



1.800.845.8345
www.insinkerator.com/foodservice



The Emerson logo is a trademark and service mark of Emerson Electric Co.

InSinkErator may make improvements and/or changes in the specifications at any time, in its sole discretion, without notice or obligation and further reserves the right to change or discontinue models.

© 2008 InSinkErator, a division of Emerson Electric Co. All Rights Reserved.