

C175 Series

USER MANUAL FOR THE METRO C175 SERIES UNINSULATED HEATED CABINET

**Recommended Food Holding
Guidelines Listed on page 7.**



InterMetro Industries Corporation
Wilkes-Barre, PA 18705
570-825-2741



TABLE OF CONTENTS

SECTION	PAGE
I. Introduction	
A. Identifying Your Cabinet	2
B. Features	3
II. Operating Instructions	
A. Reversible Door	3
B. Slide Rack Assemblies	3
C. Holding Module	4
D. Combo Module	5
E. Proofer Module	6
III. Food Holding Guidelines	
A. CM2000/HM2000 Recommended Food Holding Guidelines	7
IV. Cleaning Instructions	
A. Specific Cleaning Instructions	8
B. General Cleaning Instructions	8
V. Maintenance	
A. Cabinet Maintenance	9
B. Module Maintenance	9
C. Blower Motor Maintenance	9
VI. Replacement Parts and Procedures	
A. Cabinet	10
B. Modules	12
VII. Wiring Schematics	
A. Holding	16
B. Combo	17
C. Proofer	18

I. INTRODUCTION

A. IDENTIFYING YOUR CABINET

Your cabinet assembly has been shipped in two cartons. The first carton contains the cabinet with module. The other carton contains the slide racks.

There are several component numbers which you may want to record for future reference: the cabinet model number, the module model number along with the module serial number and the slide rack model number. Refer to the photo at right to locate these numbers. The slide rack model number is located on the label affixed to the ends of the rack carton. It is recommended that all numbers be recorded in an appropriate place, such as at the bottom of this page. Also, please record the cabinet model number and module serial number on the Warranty Card found at the back of this manual. Be sure to complete the remainder of the Warranty Card and return it to Metro within fifteen (15) days of delivery of the cabinet. Once you have located and recorded these numbers, refer to the sample numbers given below to identify the components of your C175 series cabinet.

Your C175 series cabinet has a full-view polycarbonate door which allows unobstructed viewing of the cabinet contents. To prevent shipping damage to the clear panel, the protective paper masking the panel, has been left on. Before putting your cabinet into service, be sure to remove the masking. Should the masking be difficult to remove, refer to the Specific Cleaning Instructions section of this manual for demasking instructions.

SAMPLE OF CABINET LABELING

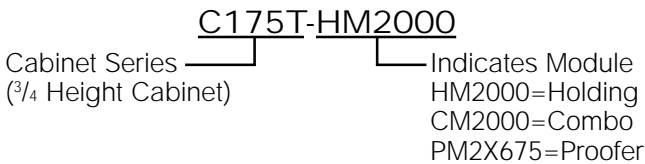
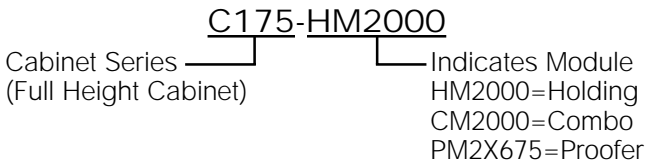

SAMPLE OF SLIDE RACK CARTON LABELING

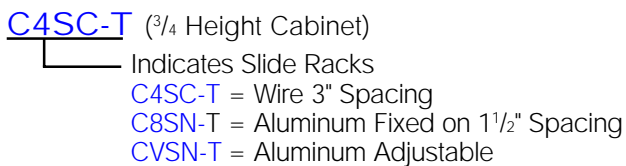
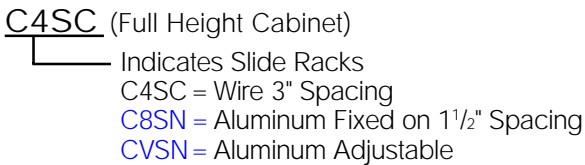

NOTE: Please read this manual thoroughly before using your cabinet. If you should have questions, please contact Metro customer service department.

B. FEATURES — ALL MODELS

In order to utilize your new cabinet to its full potential, take a minute to identify the following features which have been provided for your convenience.

- The module has been placed at the base of the cabinet for easy accessibility and efficient operation.
- Clearly-marked control panel angled for easy viewing and allowing climate adjustments without opening the door.
- Removable water pan.
- Cabinet designed with drip trough and catch pan to contain condensation drippage.
- Field reversible full-view gasketed door.
- Easy pull adjustable magnetic door latch.
- Rear pan stop.
- Cord keeper at rear of cabinet which folds flat to prevent damage to surrounding walls.
- All components — door, module, chimney, slide racks — removable to permit thorough, obstruction-free cleaning.

II. OPERATING INSTRUCTIONS

A. REVERSIBLE DOOR

The door on your cabinet can be reversed to accommodate a right- or left-hand opening. The cabinet has been shipped with the hinges mounted on the right-hand side. To reverse, follow the instructions listed below:

1. With the door in the closed position remove the hinge pin by driving it out using a hammer and a drive pin or small diameter screwdriver.
2. Once the pins are removed grasp the door firmly and pull the latch lever, this will release the door. Set the door aside being careful not to damage the gasket.
3. Remove the screws from the left side of the cabinet and set aside. Then remove the cabinet mounted part of the hinge and remount to the left side of the cabinet. Put the screws removed from the left side of the cabinet, into the remaining holes on the right side of the cabinet. Tighten all screws before proceeding.
4. Relocate the latch plate(s) from the left side to the right by removing the two mounting screws. Tighten all screws before proceeding.
5. Rotate the door 180 degrees and align the door mounted hinge part with the cabinet mounted hinge part and tap the hinge pin into place so top of pin is flush with top of the cabinet mounted hinge part. Invert the door latch by removing black plastic screw covers and remove the screws holding the latch in place.
6. Relocate the label on the door. Be sure that there are no open screw holes on the front of the cabinet.

B. SLIDE RACK ASSEMBLIES

All three models of slide racks, C4SC, C8SN, and CVSN are removable for thorough cleaning.

On the inside of each cabinet are a series of rack hangers. These hangers have two slots for either an inboard or outboard rack position. To remove the slide rack, grasp and move upward until pins are free of hanger slots. To install racks, locate pins over hangers and lower until locked into the slots.

NOTE: For an inboard rack position, use the slots farthest away from the inside wall of the cabinet. For an outboard rack position, use the slots closest to the inside wall of the cabinet.

C4SC — Model 4 (3" Slide Spacing-fixed)

The Model 4 Slide Rack consists of two sets of slides. Both sets can be installed either in an inboard or an outboard position. Also, one set of racks can be placed in the inboard position while the second set can be installed in the outboard position. All pans are to be bottom loaded regardless of rack positioning. The following pans may be used:

Inboard Hanger Position (18" width)

17 pans — 18"x26"x2⁵/₈"**

17 pans — 14"x18"x2⁵/₈"**

Max. pan size: 18"x27"x2⁵/₈"**

Min. pan size: 17"

Outboard Hanger Position (20" width)

17 pans — 20"x24"x2¹/₄"**

14 pans — 20"x24"x2⁵/₈"**

34 pans — 12"x20"x2¹/₄"**

28 pans — 12"x20"x2⁵/₈"**

Max. pan size: 20"x27"x2⁵/₈"**

Min. pan size: 19"

*The top rack level is usable if the pan and product do not exceed 2" in height.

If this condition exists, an extra pan can be held.

C8SN — Model 8 (1½" Spacing-fixed)

The Model 8 Slide Rack can only be installed in the inboard hanger position. All pans are to be lip loaded. The following pans may be used: 35 pans — 18"x26" max. height 1³/₈". Max. pan size: 18"x27"x1³/₈". Min. pan size: 18".

CVSN — Model V (adjustable)

The Model V Slide Rack can be installed in either an inboard or outboard position. Center spacing on slides can be either 3" or 4½". Slides can be removed by lifting upward and sliding the rivet heads out of the keyhole slots. To install, select spacing, insert the rivet heads into the keyhole slots and push down until locked in the hole. All pans are to be bottom loaded regardless of slide or rack positioning.

With the racks in the inboard position (18" width), the following pans may be used:

3" Slide Spacing

17 pans — 18" x26" x2⁵/₈"

34 pans — 12"x18"x2⁵/₈"

34 pans — 13"x18"x2⁵/₈"

17 pans — 14"x18"x2⁵/₈"

Max. or combined pan size:

18"x27"x2⁵/₈"

Min. pan width: 16"

4½" Slide Spacing

11 pans — 18"x26"x4¹/₈"

22 pans — 12"x18"x4¹/₈"

22 pans — 13"x18"x4¹/₈"

22 pans — 14"x18"x4¹/₈"

Max. or combined pan size:

18"x27"x4¹/₈"

Min. pan width: 18"

With the racks in the outboard position (20" width), the following pans may be used:

3" Slide Spacing

17 pans — 15"x20"x2⁵/₈"

34 pans — 10⁷/₈"x19³/₄"x2⁵/₈"

34 pans — 11¹/₈"x20"x2⁵/₈"

17 pans — 20"x20"x2⁵/₈"

17 pans — 20"x22"x2⁵/₈"

34 pans — 12"x20"x2⁵/₈"

17 pans — 20"x24"x2⁵/₈"

Max. or combined pan size:

20"x27"x2⁵/₈"

Min. pan width: 16"

4½" Slide Spacing

11 pans — 15"x20"x4¹/₈"

22 pans — 10⁷/₈"x19³/₄"x4¹/₈"

22 pans — 11¹/₈"x20"x4¹/₈"

11 pans — 20"x20"x4¹/₈"

11 pans — 20"x22"x4¹/₈"

22 pans — 12"x20"x4¹/₈"

11 pans — 20"x24"x4¹/₈"

Max. or combined pan size:

20"x27"x4¹/₈"

Min. pan width: 18"

C. HOLDING MODULE

For Recommended Holding Temperatures, see HM2000 guidelines on page 7.

When equipped with a holding module, your cabinet is designed to maintain the temperature of HOT prepared foods. The holding module is equipped with a thermostatically controlled heater, a blower for air circulation and a water pan. A POWER switch is provided with a red light to indicate when the unit is switched ON. Beside the POWER switch is the TEMPERATURE thermostat and its yellow indicator light.

A three-wire grounded lead cord is supplied fixed to the module. The cord cannot be separated from the module, thus, upon module removal be careful of the cord passing through the cabinet wall. Likewise when installing the module into a cabinet, the cord must first be fed through the opening in the cabinet back panel.

1. With the POWER switch OFF, plug the cord into a standard grounded 20 amp, 125VAC receptacle. REFER TO CABINET DATA PLATE FOR AMPERE RATING.

CAUTION: THE WATER PAN MUST BE IN PLACE DURING MODULE OPERATION.

2. To introduce limited humidity, fill the 1½-quart capacity water pan to ½" from the top with HOT clean tap water. During operation, check the water level every 3 hours and refill as necessary. The unit may be operated without water if humidity is not desired.
3. Snap POWER switch to ON. The red POWER light will now glow as will the yellow indicator light, and the blower will begin circulating air. **NOTE: This is not a foot switch.** Using it as a foot switch can damage the switch and make the cabinet inoperable.
4. Turn the TEMPERATURE thermostat to a setting of 10. The holding unit is now in operation.
5. After allowing the cabinet to PREHEAT FOR APPROXIMATELY 45/60 MINUTES, reduce the thermostat setting to 6/8. In a room of average temperature (72°F), this should provide 150°-170°F. Adjustments to the temperature may be made as necessary.

THIS IS A HOT FOOD HOLDING CABINET AND IS NOT INTENDED TO RETHERMALIZE COLD FOOD. MAKE SURE FOOD AND CABINET ARE AT PROPER TEMPERATURES BEFORE PLACING FOOD IN THE CABINET.

NOTE: The POWER (red) light will glow as soon as the POWER switch is switched ON and will continue to glow until switched OFF. The yellow indicator light will go on and off as the thermostat cycles. The blower will operate as long as the POWER switch is ON. If the yellow light is not illuminated, this indicates that the cabinet has achieved the preset TEMPERATURE level, NOT that the unit has been switched OFF.

It is not necessary at the end of the operating day to disrupt the TEMPERATURE setting in order to turn the unit OFF. By switching the POWER switch to OFF, the unit is no longer operating. By switching the POWER switch to ON when resuming operations, the cabinet will attain the preset level.

D. COMBINATION HOLDING/PROOFING MODULE

For Recommended Holding Temperatures, see CM2000 guidelines on page 7.

When equipped with a combination holding/proofing module, your cabinet is designed for proofing dough products (proof mode) or maintaining the temperature of HOT prepared foods (heat mode). The combination holding/proofing module is equipped with three thermostatically controlled heaters, a blower for air circulation and a water pan. A POWER switch is provided with a red light to indicate when the unit is switched ON. Beside the POWER switch are the TEMPERATURE and HUMIDITY thermostats, each with a yellow indicator light. Located between the thermostats is the switch for selecting PROOF mode or HEAT (holding) mode operation.

A three-wire grounded lead cord is supplied fixed to the module. The cord cannot be separated from the module, thus, upon module removal be careful of the cord passage through the cabinet wall. Likewise when installing the module into a cabinet, the cord must first be fed through the opening in the cabinet back panel.

Proof Mode Operation

In the PROOF mode, the HUMIDITY thermostat controls the heat element under the water pan to produce moist heat (humidity) while the TEMPERATURE thermostat controls the heat element in the air duct to produce dry heat.

1. With POWER switch OFF, plug lead cord into a standard grounded 20 amp, 125VAC receptacle. REFER TO CABINET DATA PLATE FOR AMPERE RATING.

CAUTION: THE WATER PAN MUST BE IN PLACE DURING MODULE OPERATION.

2. Fill the 2¹/₂-quart capacity water pan to ¹/₂" from top with HOT clean tap water. During operation, check water level every 2 hours and refill as necessary.
3. Move the selector switch to PROOF position. Snap POWER switch to the ON position. The red POWER light will now glow and the blower will begin operating. **NOTE: This is not a foot switch. Using it as a foot switch can damage the switch and make the cabinet inoperable.**
4. For products that will proof in 30-45 minutes at approximately 95°F and 95% relative humidity, turn the HUMIDITY thermostat to

setting 10 and TEMPERATURE thermostat to setting 2. Given a normal room temperature of 72°F, a PREHEAT TIME OF APPROXIMATELY 30 MINUTES is required before proofing can begin. For products that require more than 45 minutes to proof, it will probably be necessary to reduce the HUMIDITY setting to avoid a 100% relative humidity condition during the proofing cycle. HUMIDITY SETTINGS THAT ARE TOO HIGH WILL RESULT IN EXCESS WATER CONDENSING ON THE INSIDE OF THE DOOR AND POSSIBLE CABINET LEAKAGE.

Individual adjustments of temperature and humidity may be made as necessary.

NOTE:The POWER (red) light will glow as soon as the POWER switch is switched ON and will continue to glow until switched OFF. The yellow indicator lights will go on and off as their controls cycle; the blower will operate as long as the POWER switch is ON. If the yellow lights are not illuminated, this indicates that the cabinet has achieved the preset levels, NOT that the unit has been switched OFF.

It is not necessary at the end of the operating day to disrupt the TEMPERATURE and HUMIDITY settings in order to turn the unit OFF. By switching the POWER switch to OFF, the unit is no longer operating. By switching the POWER switch to ON when resuming operations, the cabinet will attain the preset levels.

Heat Mode Operation

In the HEAT mode, the TEMPERATURE thermostat controls one heat element in the air duct to produce dry heat.

1. With POWER switch OFF, plug lead cord into a standard grounded 20 amp, 125VAC receptacle. REFER TO CABINET DATA PLATE FOR AMPERE RATING.

CAUTION: THE WATER PAN MUST BE IN PLACE DURING MODULE OPERATION.

2. To introduce limited humidity, fill the water pan to ¹/₂" from top with HOT clean tap water. During operation, check water level every 3 hours and refill as necessary. The unit may be operated without water if humidity is not desired.
3. Move selector switch to HEAT position. Snap POWER switch to ON. The red POWER light will now glow, as will the yellow indicator light adjacent to the TEMPERATURE thermostat. The blower will begin circulating air. **NOTE: This is not a foot switch. Using it as a foot switch can damage the switch and make the cabinet inoperable.**
4. Turn the TEMPERATURE thermostat to setting 10. The unit is now operating in the HEAT mode.
5. After allowing the cabinet to PREHEAT FOR APPROXIMATELY 45/60 MINUTES, reduce the thermostat setting to 6/8. In a room of

average temperature (72°F), this should provide 150°-170°F. Adjustments to the temperature may be made as necessary.

THIS IS A HOT FOOD HOLDING CABINET AND IS NOT INTENDED TO RETHERMALIZE COLD FOOD. MAKE SURE FOOD AND CABINET ARE AT PROPER TEMPERATURES BEFORE PLACING FOOD IN THE CABINET.

NOTE: The POWER (red) light will glow as soon as the POWER switch is turned ON and will continue to glow until switched OFF. The yellow indicator light(s) will go on and off as their controls cycle. The blower will operate as long as the POWER switch is ON. If the yellow light(s) are not illuminated, this indicates that the cabinet has achieved the preset level(s), NOT that the unit has been switched OFF.

It is not necessary at the end of the operating day to disrupt the TEMPERATURE setting in order to turn the unit OFF. By switching the POWER switch to OFF, the unit is no longer operating. By switching the POWER switch to ON when resuming operations, the cabinet will attain the preset level.

E. PROOFER MODULE

When equipped with a proofer module, your cabinet is designed for proofing dough products. The proof module is equipped with two thermostatically controlled heaters — one for dry heat (TEMPERATURE) and one for moist heat (HUMIDITY), a blower for gentle air circulation and a water pan. A POWER switch is provided with a red light to indicate when the unit is switched ON. Beside the POWER switch are the separate TEMPERATURE and HUMIDITY thermostats, each with a yellow indicator light.

A three-wire grounded lead cord is supplied fixed to the module. The cord cannot be separated from the module, thus, upon module removal be careful of the cord passage through the cabinet wall. Likewise when installing the module into a cabinet, the cord must first be fed through the opening in the cabinet back panel.

1. With POWER switch OFF, plug lead cord into a standard grounded 15-amp, 125VAC receptacle. **CAUTION: THE WATER PAN MUST BE IN PLACE DURING MODULE OPERATION.**
2. Fill the 2¹/₂-quart capacity water pan to ¹/₂" from top with HOT clean tap water. During operation, check water level every 2 hours and refill as necessary.
3. Snap POWER switch to the ON position. The red POWER light will now glow and the blower will also begin operating. **NOTE: This is not a foot switch.** Using it as a foot switch can damage the switch and make the cabinet inoperable.

4. For products that will proof in 30-45 minutes at approximately 95°F and 95% relative humidity, turn the HUMIDITY thermostat to setting 10 and TEMPERATURE thermostat to setting 2. Given a normal room temperature of 72°F, a PREHEAT TIME OF APPROXIMATELY 30 MINUTES is required before proofing can begin. For products that require more than 45 minutes to proof, it will probably be necessary to reduce the HUMIDITY setting to avoid a 100% relative humidity condition during the proofing cycle. HUMIDITY SETTINGS THAT ARE TOO HIGH WILL RESULT IN EXCESS WATER CONDENSING ON THE INSIDE OF THE DOOR AND POSSIBLE CABINET LEAKAGE.

Individual adjustments of temperature and humidity may be made as necessary.

NOTE: The POWER (red) light will glow as soon as the POWER switch is switched ON and will continue to glow until switched OFF. The yellow indicator lights will go on and off as their controls cycle. The blower will operate as long as the POWER switch is ON. If the yellow lights are not illuminated, this indicates that the cabinet has achieved the preset levels, NOT that the unit has been switched OFF.

It is not necessary at the end of the operating day to disrupt the TEMPERATURE and HUMIDITY settings in order to turn the unit off. By switching the POWER switch to OFF, the unit is no longer operating. By switching the POWER switch to ON when resuming operations, the cabinet will attain the preset levels.

III. FOOD HOLDING GUIDELINES

A. CM2000/HM2000

Recommended Food Holding Guidelines

Food Product	Covered/Uncovered	Temperature Setting °F*
Baked Fish	Uncovered	175
Baked Potatoes	Uncovered	180
Biscuit	Uncovered	180
Broccoli	Covered	170-175
Chicken Nuggets	Uncovered	175
Corn on the Cob	Covered	170-175
Croissants	Uncovered	175
Egg Patties	Covered	180
French Fries**	Uncovered	185
Fried Chicken	Uncovered	180-185
Fried Fish	Uncovered	180
Hamburgers	Covered	180
Lasagna	Covered	185
Mashed Potatoes	Covered	175
Mixed Veggies	Covered	170-175
Pancakes	Covered	175
Pasta	Covered	180
Peas	Covered	170-175
Pizza	Uncovered	175-180
Roast Beef	Uncovered	170-180
Roast Pork	Uncovered	170-180
Scalloped Potatoes	Covered	175
Strip Steak	Uncovered	160-170
Turkey	Uncovered	170-180
Waffles	Covered	175
Whole Chicken	Uncovered	170-180

*Temperatures are guidelines only, based on opening cabinet doors every 15 minutes.

**Lightly salted for best quality.

Developed by Penn State University School of Hotel, Restaurant, and Recreation Management

IV. CLEANING INSTRUCTIONS

CAUTION

AT NO TIME SHOULD THE MODULE OR CABINET BE WASHED OR FLOODED WITH WATER OR LIQUID SOLUTION. NEVER STEAM CLEAN. SEVERE DAMAGE OR ELECTRICAL HAZARD COULD RESULT.

1. Turn off master switch.
2. Disconnect the unit from its power source.

WARNING

ALLOW THE UNIT TO COOL BEFORE CLEANING, AS THE INTERIOR OF THE CABINET MAY BE HOT ENOUGH TO BURN. ALSO ALLOW THE WATER IN THE PAN TO COOL BEFORE REMOVAL.

3. Open the door(s) and remove the slide racks and chimney.
4. If there is water in the pan, remove and empty.
5. Remove the module from the cabinet by lifting up the front enough to clear its detent, then pull the module away from the cabinet. The power cord slips through the clearance hole at the rear of the cabinet.
6. Do not use abrasive cleaners. For every cleaning method, best results are always obtained when the cleaner and technique are matched to the soil conditions involved. Contact your detergent representative to ensure the cleaning product being used is recommended for use on natural and epoxy coated aluminum. Follow the manufacturer's directions on cleaners. Never mix cleaners.
7. After cleaning, replace all components. Make sure the slide racks and chimney are seated in the hangers correctly.

A. SPECIFIC CLEANING INSTRUCTIONS

1. Do not immerse the module when cleaning. Instead, use a damp cloth and a drying towel. Special attention should be paid to keeping the air-inlet area and the controls area free of dirt build-up. BE SURE TO THOROUGHLY DRY THE MODULE BEFORE RETURNING IT TO USE.
2. The protective masking on the polycarbonate door may be removed by simply peeling it from the door, starting at a top corner and working downward. Should the masking be difficult to peel, polycarbonate sheet demasking agents are commercially available and give excellent results. For regular cleaning, a soft cotton flannel cloth and a cleaner recommended by its manufacturer for use on polycarbonate plastics is suggested. Do not use synthetic cloths or cleaners not intended for polycarbonate plastics as these will scratch and dull the polycarbonate door panel.

Additional hints for keeping the door panel clean and clear:

- a. Isopropyl (rubbing) alcohol, used as a cleaner, will aid in removing grease smudges and fingerprints.
 - b. A small amount of liquid dish detergent in a bucket of water will help remove heavier dirt and will help make the clear panel antistatic and therefore less likely to attract dust.
 - c. A paste-wax recommended for polycarbonate plastics and approved for food service equipment will hide small scratches and return the luster and clarity to the clear door panel as well as reduce the electrostatic attraction of dust.
3. Do not neglect to clean the under-chassis area, especially the area above each caster.
 4. The cabinet or component(s) must be thoroughly rinsed to remove any residue that may stain the materials.
 5. When choosing a cleanser, make sure the cleanser manufacturer recommends its use on natural and epoxy-coated aluminum.

B. GENERAL CLEANING INSTRUCTIONS

1. LIGHT SOIL

If routine (daily) cleaning is practiced, a mild soap and warm water should be sufficient to keep the unit clean.

2. HEAVIER SOIL

If cleaning has been postponed, solvent or emulsion type cleaners that can be applied with bare hands will give excellent results. Such cleaners are available under various brand names and detergent suppliers can recommend materials appropriate for use on natural and epoxy-coated aluminum.

NOTE: For every cleaning method, best results are always obtained when the cleaner and technique are matched to the soil conditions involved. To ensure using the proper cleaner for natural and epoxy-coated aluminum, contact your detergent representative.

V. MAINTENANCE

A. CABINET MAINTENANCE — ALL MODELS

Your C175 series cabinet has been designed to require very little maintenance. With normal use, cleaning is the only form of maintenance that need be done on a regular basis. Keeping the casters free of dirt build-up will go a long way in prolonging their life.

If your cabinet is rolled over rough surfaces or transported over-the-road, the various threaded fasteners, i.e., screws and nuts, should be periodically inspected and tightened if necessary, particularly the transport latch, hinge and caster fasteners.

B. MODULE MAINTENANCE

The module in the base of your cabinet has also been designed to require very little maintenance. With normal use, cleaning is the only form of maintenance that need be done on a regular basis. When cleaning, do not spray or pour water on the module and do not immerse the module in water. Wipe with a damp cloth and dry with a towel. Keeping vital areas such as the air-inlet area and the controls area free of dirt build-up will go a long way in prolonging the life of the electrical components. No maintenance is required on the electrical components.

C. BLOWER MOTOR MAINTENANCE

The blower motor bearings should be lubricated annually.

1. To gain access to the motor, follow the instructions listed on page 12.
2. Remove the (2) rubber plugs, (1) located at each end of motor.
3. Apply 6 drops of a SAE 20 non-detergent oil to each bearing and re-install plugs.
4. Re-assemble module.

VI. REPLACEMENT PARTS AND PROCEDURES

A. CABINET — ALL MODELS

Refer to the Cabinet Replacement Parts Diagram on next page to identify the replacement parts.

C175 Series Cabinet Replacement Parts Diagram

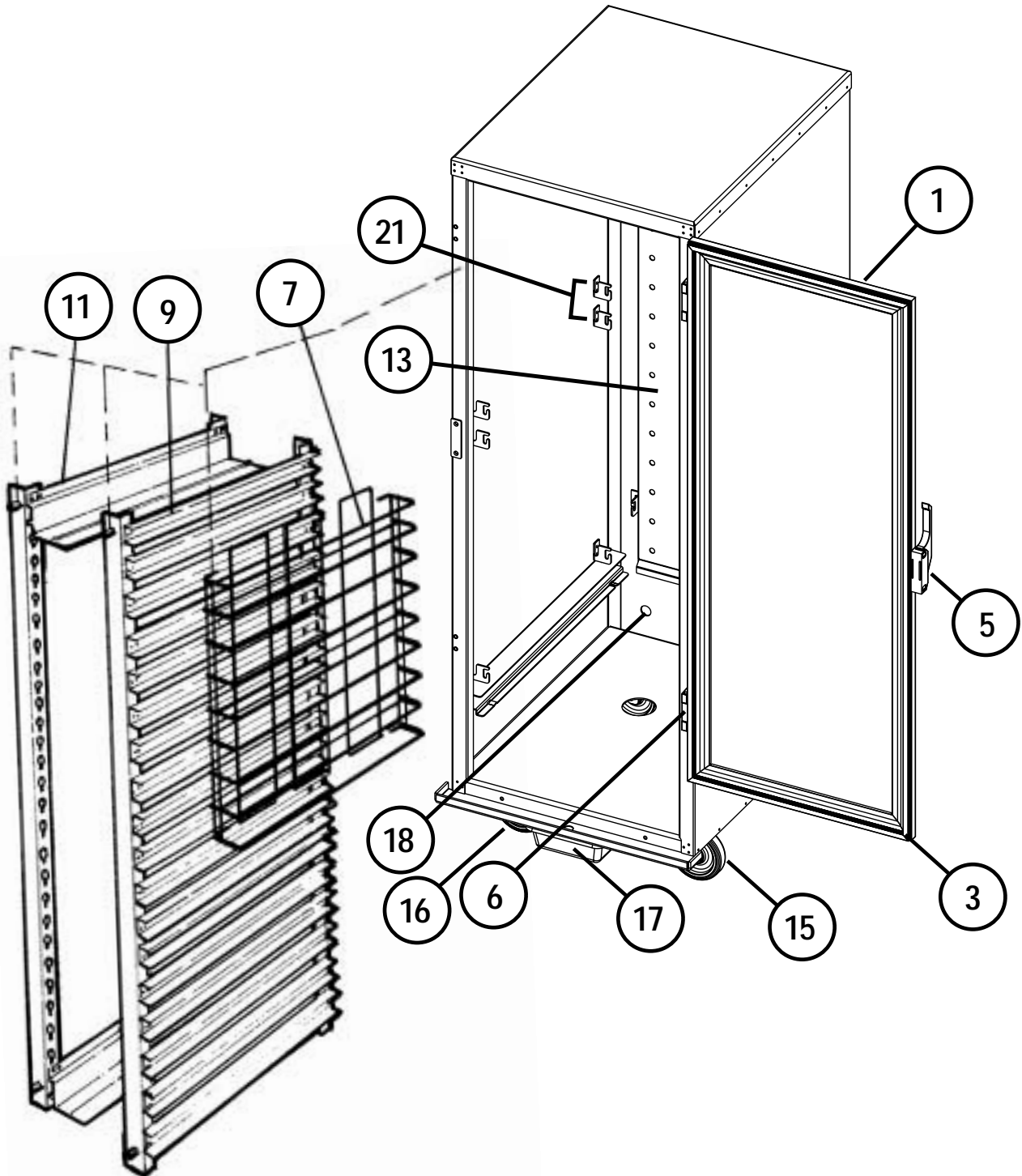

VI. REPLACEMENT PARTS LIST

(³/₄ height cabinet parts not shown)

Item No.	Part No.	Description
1	RPC175P-1106	Door (full height cabinet)
2	RPC175TP-1106	Door (³ / ₄ height cabinet)
3	RPC06-812	Gasket (full height cabinet)
4	RPC06-813	Gasket (³ / ₄ height cabinet)
5	RPC14-118	Door Latch — Strike Plates Included
6	RPC14-119	Door Hinge — Complete Assembly
7	C4SC	C4SC Rack (full height cabinet) <i>(2 required for entire cabinet)</i>
8	C4SC-T	C4SC-T Rack (³ / ₄ height cabinet)
9	C8SN	C8SN Rack (full height cabinet)
10	C8SN-T	C8SN-T Rack (³ / ₄ height cabinet)
11	CVSN	CVSN Rack (full height cabinet)
12	CVSN-T	CVSN-T Rack (³ / ₄ height cabinet)
13	RPC175-1108	Chimney (full height cabinet)
14	RPC199T-1108	Chimney (³ / ₄ height Cabinet)
15	B5DNB	Caster With Brake
16	B5DN	Caster Without Brake
17	RPC06-179A	Drip Trough Pan — Plastic
18	RPC13-106	Snap Bushing
19	RPCAB-HBMPR	Handle Bumper (Not Shown)
20	RPC06-067	Cabinet Bumper (Not Shown)
21	RPHANG-KIT	Rack Hanger Kit (2 right-hand and 2 left-hand hangers)

B. MODULES — ALL MODULES

Your module has been designed to be user-serviceable, assuming a basic knowledge of the operation of electrical devices. This section has been written to guide the user step by step, and in layman's terms, through the dismantling and servicing of the module. Before attempting to service your module, read the appropriate Module Repair Procedures (found elsewhere in this section) thoroughly. If you do not understand the Repair Procedures or prefer not to service your module yourself, or if your warranty is still in effect, please contact our Customer Service Department for the factory authorized service agency nearest you.

DANGER: HAZARDOUS VOLTAGE. DISCONNECT POWER BEFORE SERVICING OR CLEANING.

The lead cord plug configuration designates whether your module uses a 15 or 20 amp service. Refer to the illustration below to identify the two different plugs.

15 AMP PLUG

20 AMP PLUG

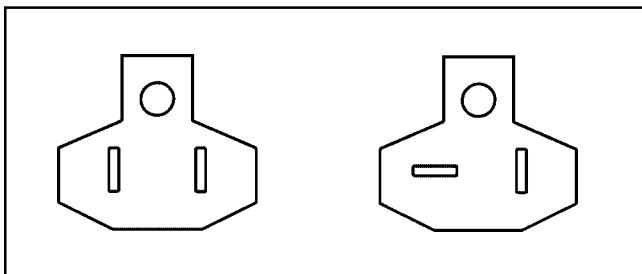

**PM2X675
MODULES**

**HM2000, CM2000
MODULES**

CAUTION: IT IS IMPORTANT THAT ALL SAFETY PRECAUTIONS PERTAINING TO THE SERVICING OF ELECTRICAL DEVICES BE OBSERVED AT ALL TIMES.

1. Dismantle your module for servicing per the following instructions.

NOTE: To replace the Thermostat Knob or water pan, it is not necessary to dismantle the module.

- a. Make sure the lead cord is **not** plugged into an outlet. Be certain that the module and any water in the water pan has cooled to a temperature safe for handling.
- b. Remove module by lifting the front enough to clear the detent, then pull the module from the cabinet, grasping it with both hands as it clears the cabinet. The cord should slip through the clearance hole in the back of the cabinet.

- c. Remove the water pan and drain water from pan.
- d. Unfasten the electrical cover by removing the three screws along the front of the module and the two screws along each edge of the module. Retain this hardware for re-assembly.
- e. Open the module by raising the component chassis from the electrical cover and placing the chassis top down on a dry, non-flammable work surface. IF NECESSARY TO RECONNECT THE OPENED MODULE TO A POWER SOURCE, PRACTICE EXTREME CAUTION SO AS NOT TO RECEIVE ELECTRICAL SHOCK FROM EXPOSED COMPONENTS.

2. Refer to the appropriate Module Replacement Parts Diagram to identify the internal components. Determine malfunctioning component(s) by electrical diagnostic procedures.
3. After servicing, be sure to verify the routing of each wire with the appropriate wiring schematic before installing electrical cover and connecting module to power source. Be sure that the thermostat sensor tube does not contact any electrical connections.
4. Assemble components using the retained hardware, making sure that no wires are pinched between the cover and the component chassis.
5. Install water pan. Then, feed cord through clearance hole in cabinet and slide module into cabinet.

Holding Module Replacement Parts Diagram

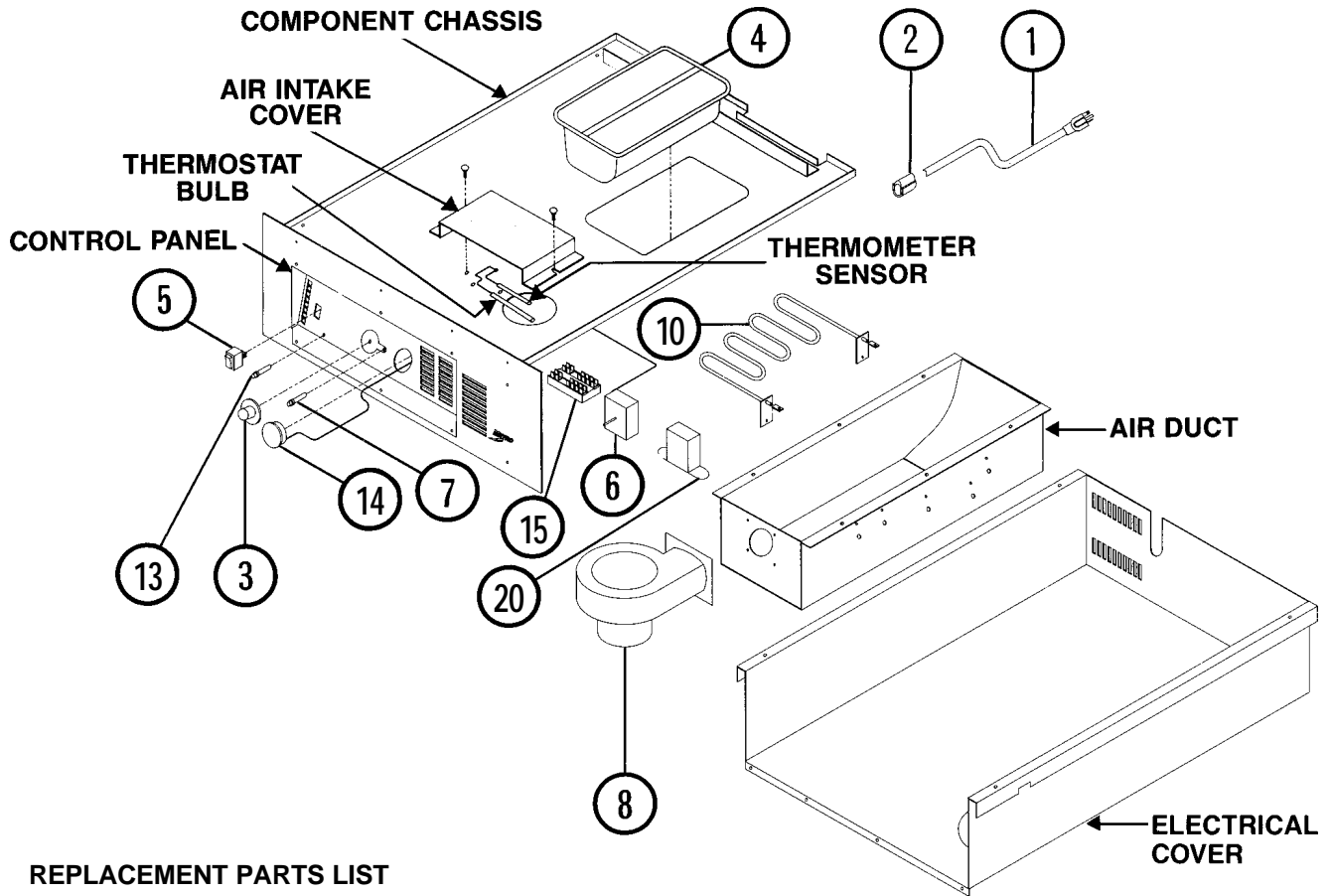

REPLACEMENT PARTS LIST

Item No.	Part No.	Description
1	RPC13-099	Power Cord — 20 AMP
2	RPC13-098	Strain Relief — 20 AMP
3	RPC06-313	Thermostat Knob
4	RPHM20-PAN	Water Pan
5	RPC13-127	Power Switch
6	RPC13-129	Temperature Thermostat
7	RPC13-105	Yellow Indicator Light
8	RPHM20-2103	Circulating Blower
9	RPC13-012	Ring Terminal
10	RPC13-093	Heat Element — Air Duct
11	RPF02-042	Push Nut — Indicator Lights
12	RPC11-191	Blower Collar
13	RPC13-064	Red Indicator Light
14	RPC13-181	Thermometer
15	RPC13-096	Terminal Block — Control Panel
16	RPC13-085	Wire Nuts — 12 GA
17	RPC07-044	Grommet — Thermometer Wire
18	RPC06-222	Thermostat Bulb Clamp
19	RPC13-027	1/4" Spade Terminals
20	RPC13-183	Thermometer Transformer

Combo Module Replacement Parts Diagram

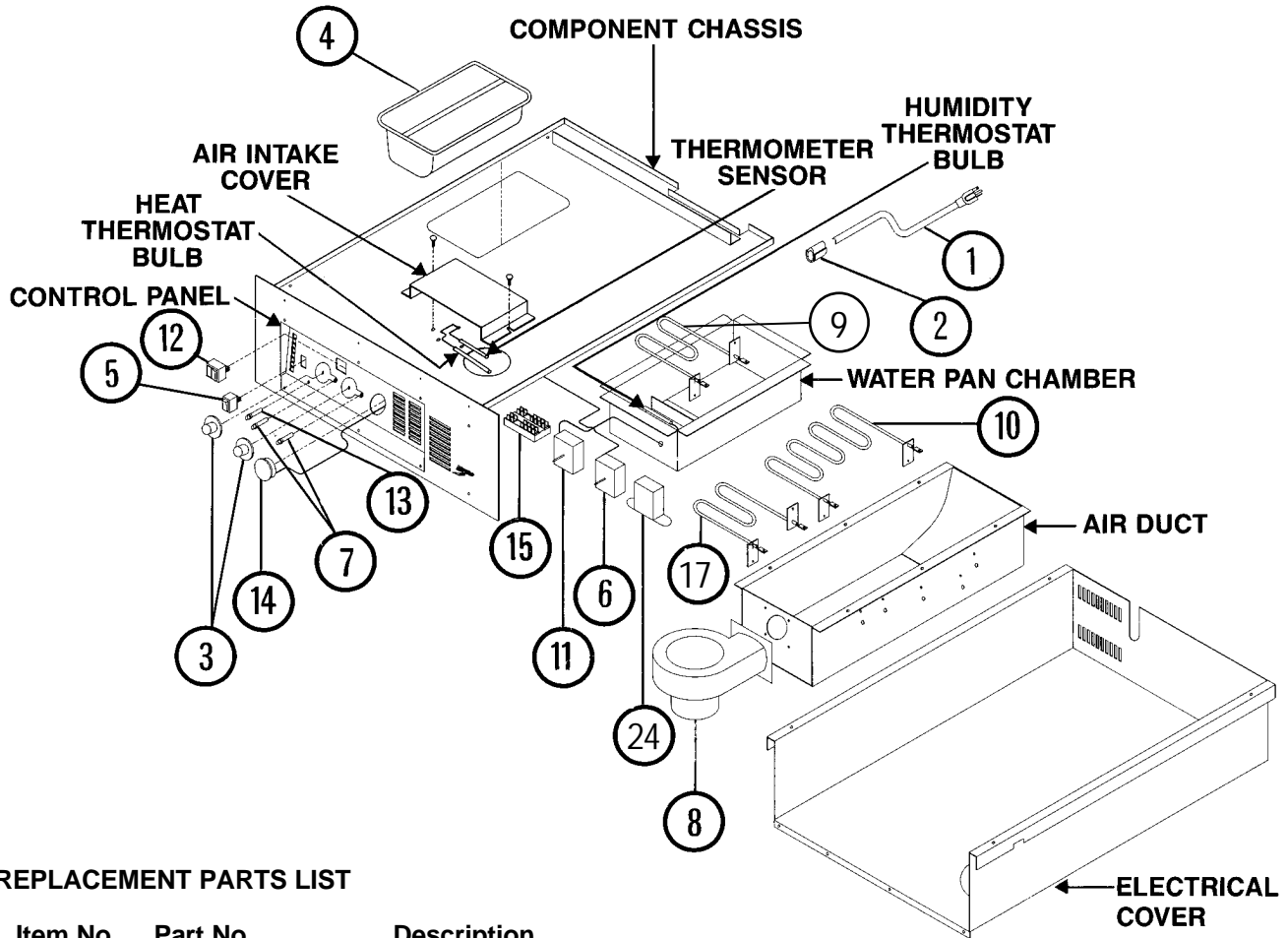

REPLACEMENT PARTS LIST

Item No.	Part No.	Description
1	RPC13-099	Power Cord — 20 AMP
2	RPC13-098	Strain Relief — 20 AMP
3	RPC06-313	Thermostat Knob
4	RPCM20-PAN	Water Pan
5	RPC13-127	Power Switch
6	RPC13-129	Temperature Thermostat
7	RPC13-105	Yellow Indicator Light
8	RPHM20-2103	Circulating Blower
9	RPC13-162	675 Watt Heat Element — Water Pan
10	RPC13-093	Heat Element — Air Duct
11	RPC13-135	Humidity Thermostat
12	RPC13-128	Selector Switch
13	RPC13-064	Red Indicator Light
14	RPC13-181	Thermometer
15	RPC13-096	Terminal Block — Control Panel
16	RPC13-012	Ring Terminal
17	RPC13-162	675 Watt Heat Element — Air Duct
18	RPF02-042	Push Nut — Indicator Lights
19	RPC11-191	Blower Collar
20	RPC13-085	Wire Nuts — 12 GA
21	RPC07-044	Grommet — Thermometer Wire
22	RPC06-222	Thermostat Bulb Clamp
23	RPC13-027	1/4" Spade Terminals
24	RPC13-183	Thermometer Transformer

Proofer Module Replacement Parts Diagram

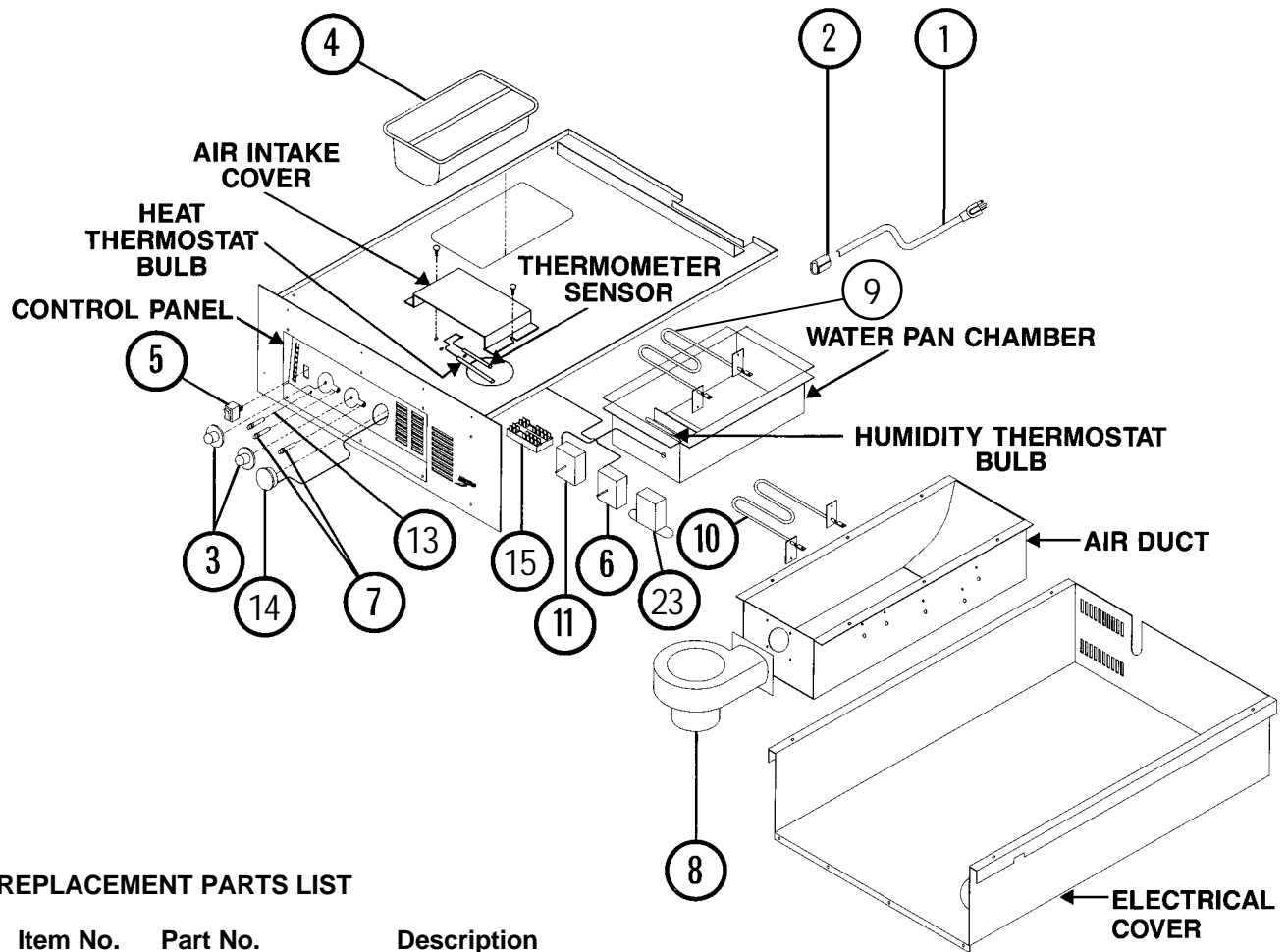

REPLACEMENT PARTS LIST

Item No.	Part No.	Description
1	RPC13-017	Power Cord — 15 AMP
2	RPC13-083	Strain Relief — 15 AMP
3	RPC06-313	Thermostat Knob
4	RPCM20-PAN	Water Pan
5	RPC13-127	Power Switch
6	RPC13-129	Temperature Thermostat
7	RPC13-105	Yellow Indicator Light
8	RPHM20-2103	Circulating Blower
9	RPC13-162	Heat Element — Water Pan
10	RPC13-162	Heat Element — Air Duct
11	RPC13-135	Humidity Thermostat
12	RPC13-128	Selector Switch
13	RPC13-064	Red Indicator Light
14	RPC13-181	Thermometer
15	RPC13-096	Terminal Block — Control Panel
16	RPC13-012	Ring Terminal
17	RPF02-042	Push Nut — Indicator Lights
18	RPC11-191	Blower Collar
19	RPC13-085	Wire Nuts — 12 GA
20	RPC07-044	Grommet — Thermometer Wire
21	RPC06-222	Thermostat Bulb Clamp
22	RPC13-027	1/4" Spade Terminals
23	RPC13-183	Thermometer Transformer

VII. WIRING SCHEMATICS
 REFER TO APPROPRIATE MODULE

HOLDING MODULE WIRING DIAGRAM

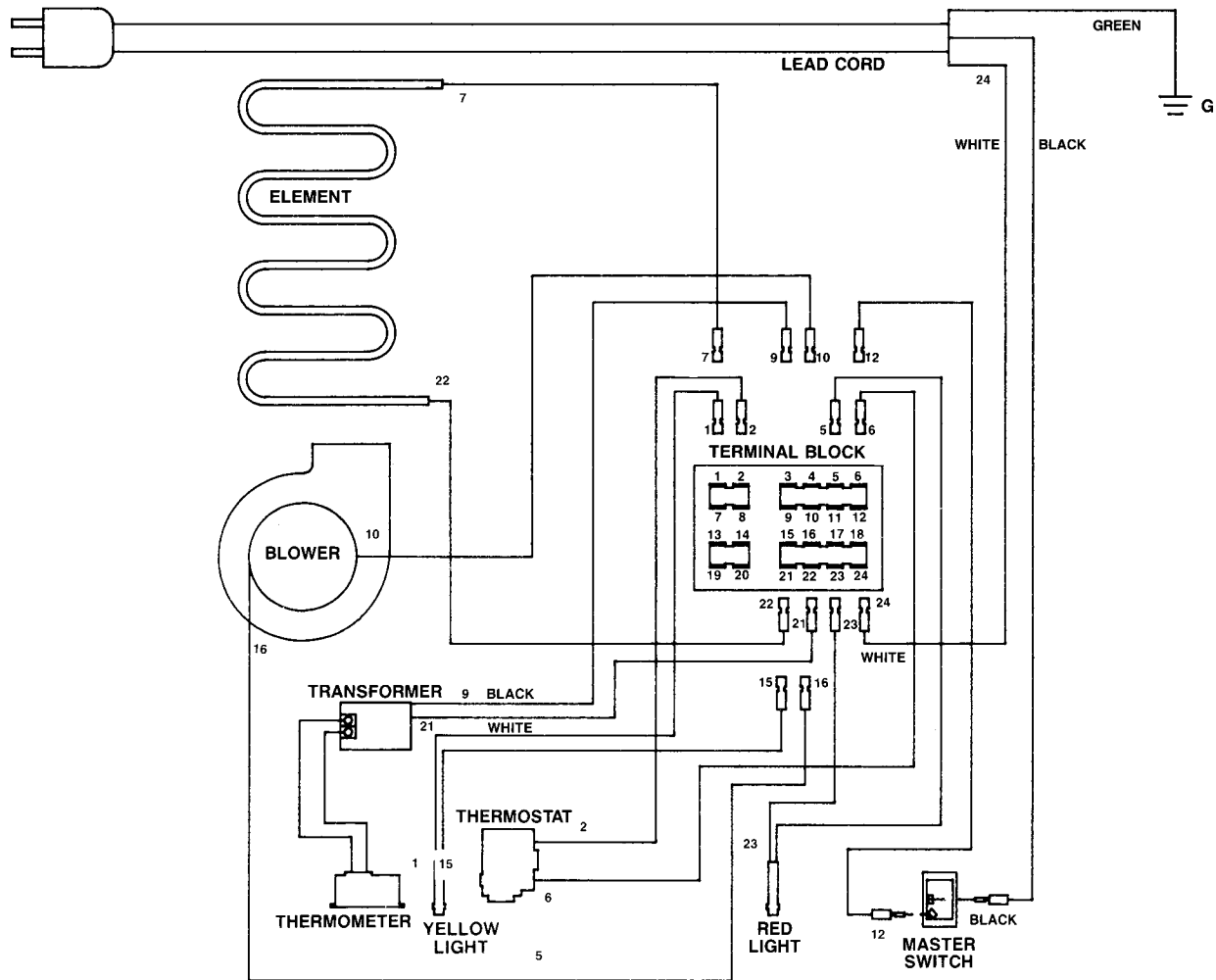

NOTE: Wiring diagrams are shown with module upside down for servicing.

COMBO MODULE WIRING DIAGRAM

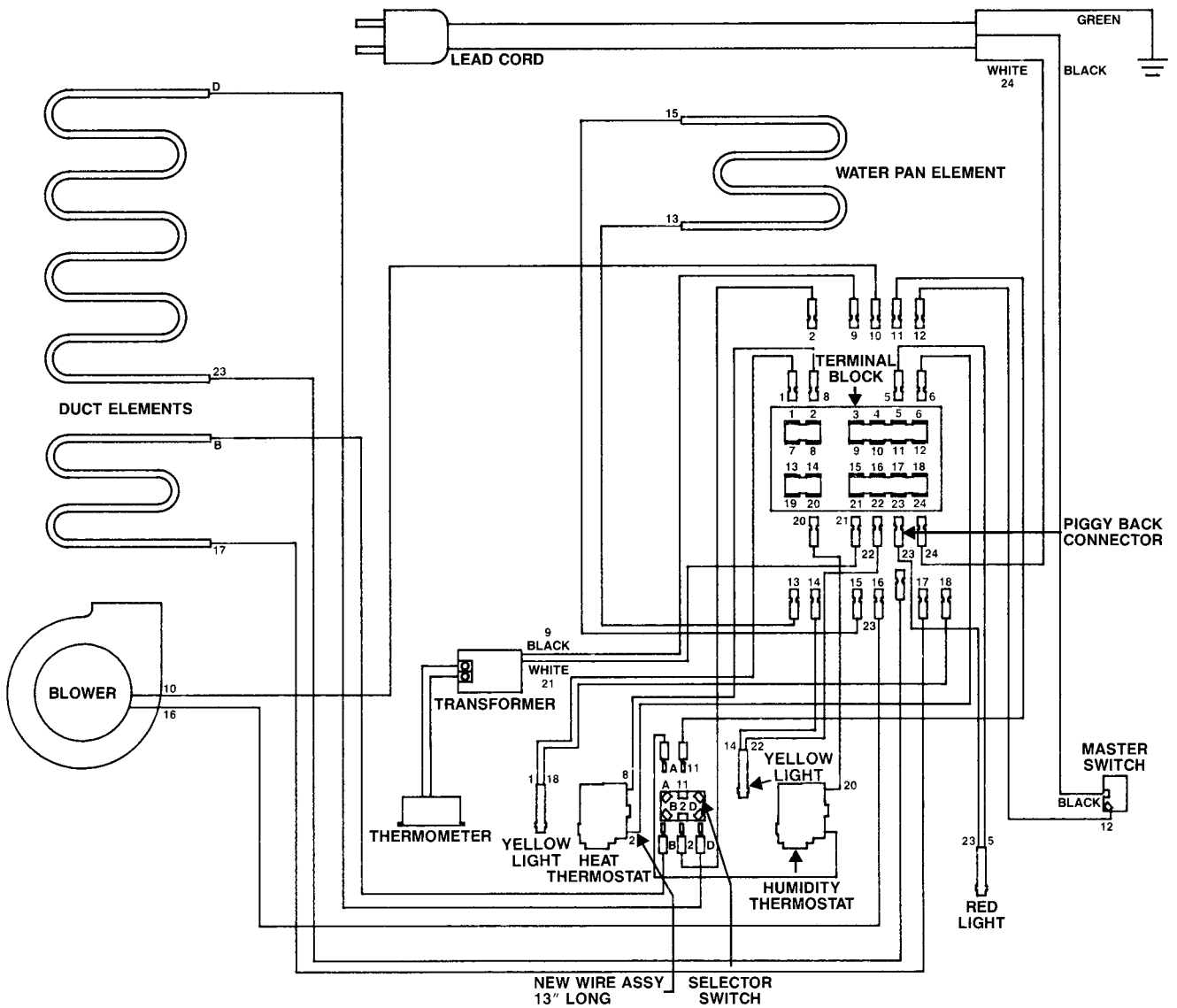

NOTE: Wiring diagrams are shown with module upside down for servicing.

PROOFER MODULE WIRING DIAGRAM

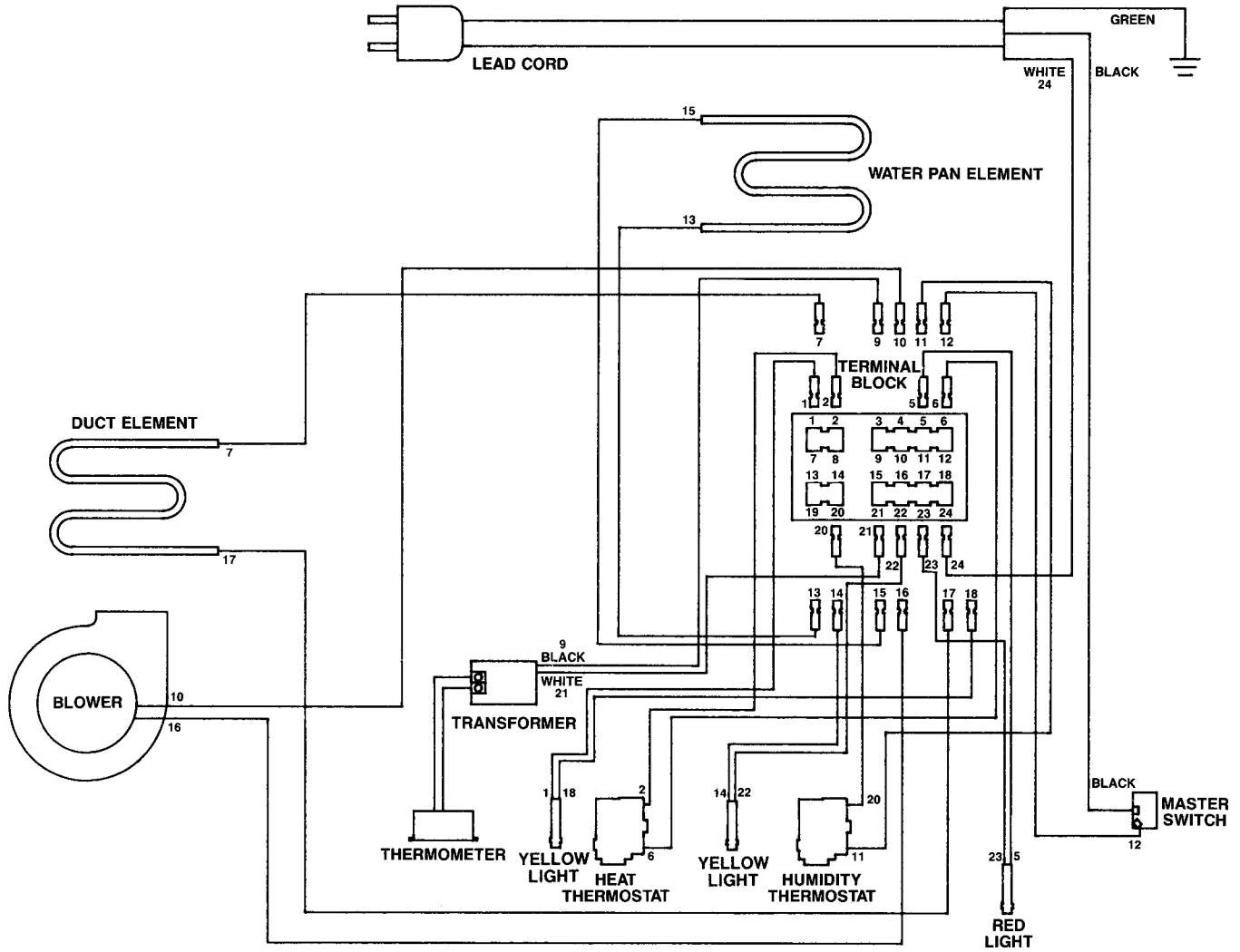

NOTE: Wiring diagrams are shown with module upside down for servicing.

Thank you for purchasing a Metro Mobile Heated Cabinet. We are certain you will be more than satisfied with its quality and performance. Please fill in the warranty information space below so we may register your warranty. Also, so that we may learn more about our customers and hopefully be of continued service in the future, please take a moment to fill in the customer information space below.

Thank You

CUT ALONG DOTTED LINE

CUSTOMER INFORMATION

1. Which one of the following best describes your establishment?

- a. Full Service Restaurant
- b. Fast Food Restaurant
- c. Hotel/Motel
- d. Hospital/Nursing Home
- e. College/University
- f. School
- g. Employee Feeding
- h. Other _____

WARRANTY INFORMATION:

Cabinet Model No. _____
 Module Serial No. _____
 Slide Rack Model No. _____
 Date Purchased _____
 Customer Name _____
 Address _____

 Phone No. _____

For warranty coverage, this card must be returned to Metro.

FOLD HERE — DO NOT DETACH

CUT ALONG DOTTED LINE

2. Please indicate the two product benefits that were of major interest to you.

- a. Visibility provided by transparent door.
- b. Accessibility to controls without opening door.
- c. All components within cabinet removable for cleaning.
- d. Better control of conditions in cabinet. (individual controls for temperature and humidity modules).
- e. Uniform environment within cabinet due to forced air circulation, chimney design and gasketed doors.
- f. Reversible door.
- g. Aesthetic quality (styling).
- h. Other (in addition to above two) _____

3. Main factor that led to your decision to purchase this product?

- a. Product operating and functional features
- b. Overall quality
- c. Price
- d. Availability
- e. Other _____

4. Three sources that led to the purchase of this product — in the order of their impact (1 - being most impact; 3 - being least impact).

- a. Trade Journal Ad
- b. Trade Show
- c. Sales Call
- d. Direct Mail
- e. Previous Purchase
- f. Other _____



WILKES-BARRE PA 18705-9968

P O BOX A

ATTN: CUSTOMER SERVICE

INTERMETRO INDUSTRIES CORPORATION

POSTAGE WILL BE PAID BY

BUSINESS REPLY MAIL
FIRST-CLASS PERMIT NO. 121 WILKES-BARRE, PA

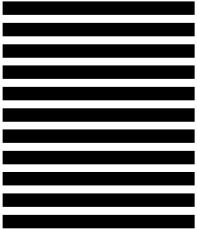

NO POSTAGE
NECESSARY
IF MAILED
IN THE
UNITED STATES

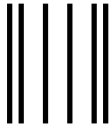

FOLD HERE — DO NOT DETACH

STAPLE HERE

STAPLE HERE

STAPLE HERE

Warranty

WARRANTY, EXCLUSION OF WARRANTIES AND LIMITATION OF LIABILITY.

InterMetro Industries Corporation (hereinafter referred to as "Seller") warrants to the original purchaser that all products in its catalog, or custom products, delivered hereunder will be free from defects in workmanship and material. **THE FOREGOING WARRANTY IS EXCLUSIVE AND IN LIEU OF ALL OTHER WARRANTIES, EXPRESS, IMPLIED OR STATUTORY, INCLUDING ANY WARRANTY OF MERCHANTABILITY OR FITNESS FOR A PARTICULAR PURPOSE.** This Warranty shall be for a period of one (1) year from the date of shipment from Seller's warehouse or factory. If any product delivered hereunder does not meet the Warranty specified above, providing the product has not been altered in any way by anyone other than Seller's factory-authorized representative, and assuming normal and proper use and maintenance, Seller will, at its option, repair or replace any part or material it determines, upon inspection, to be defective; provided however, that a charge for labor will be made except during a period of one (1) year from the date of original shipment from Seller's warehouse or factory. No product, or part thereof, is to be returned to Seller without prior written approval from Seller's factory. All exchanges and replacement shipments will be F.O.B. Seller's factory. Warranties for equipment or articles not manufactured by the Seller are solely the warranties of the manufacturers thereof and they are hereby assigned to the purchaser without recourse to the Seller.

SELLER'S LIABILITY FOR ANY CLAIM OF ANY KIND, WHETHER BASED ON CONTRACT, NEGLIGENCE OR STRICT LIABILITY IN TORT, AND BY WHOMEVER MADE, FOR ANY DIRECT, INDIRECT, INCIDENTAL OR CONSEQUENTIAL LOSS, DAMAGE OR INJURY, RESULTING TO THE PURCHASER OR ANY THIRD PARTIES, arising out of, connected with or resulting from this Agreement, or from the performance or breach thereof, or from the manufacture, sale, delivery, resale, installation, inspection, repair or use of any product covered by or furnished under this Agreement, WHETHER OR NOT CAUSED BY SELLER'S NEGLIGENCE, SHALL IN ALL EVENTS BE EXCLUSIVELY LIMITED TO THE COST OF CORRECTING DEFECTIVE, DAMAGED OR NON-CONFORMING PARTS OR MATERIAL AS HEREIN PROVIDED, and upon the expiration of one (1) year, all such liability shall terminate.

SELLER DOES NOT AUTHORIZE any person to assume for it any obligations or liabilities greater than or different than those set forth in this Warranty. The terms under which any of Seller's products may be resold must be limited in accordance with this Warranty.

THIS AGREEMENT, and all the rights and obligations arising hereunder, shall be construed in accordance with, and be governed by, the law of the Commonwealth of Pennsylvania, U.S.A.

TO INSURE WARRANTY implementation, return the completed registration card within 15 days of cabinets' receipt to: InterMetro Industries Corp., Wilkes-Barre, PA 18705



InterMetro Industries Corporation
Wilkes-Barre, PA 18705



InterMetro Industries Corporation

North Washington Street, Wilkes-Barre, PA 18705

For Product Information Call: 1-800-433-2232

Visit Our Web Site: www.metro.com

L01-385

Rev. A 03/03

Information and specifications are subject to change
without notice. Please confirm at time of order.