

Modular Hi-Rise Series

FAN COIL TECHNICAL CATALOG



A **NIBE** GROUP MEMBER



MXY

MAY/MBY

MPY

- **Cost Effective Solution**
- **Easy to Install/Service**
- **Variety of Sizes/Applications**

Modular Hi-Rise Series

FAN COIL TECHNICAL CATALOG

International Environmental Corporation (IEC) works continually to improve its products. As a result, the design and specifications of each product may be changed without notice and may not be as described herein. Please contact IEC for information regarding current design and product specifications. Statements and other information contained herein are not express warranties and do not form the basis of any bargain between the parties but are merely IEC's opinion or commendation of its products. Manufacturer's standard limited warranty applies.

Table of Contents

4	Portfolio
5-6	Features and Benefits
7-11	Product Application
12	Unit Model Key
13-14	Ratings and Listings
15-17	Fan Curves
18	Motor Performance Data
19-21	Sound Power Data
22	Electric Heating
23-29	Submittal Data
30	Coil Data
31-39	Standard Features and Options
40	Specifications
41	Filters
41	Bipolar Ionizer Specifications

Portfolio



Modular Hi-Rise Concealed (MPY) 300 CFM to 1200 CFM

The Concealed Modular (MPY) fan coil unit, International Environmental Corporation's (IEC) premier Modular unit, is designed for concealed applications in corners or along room walls. Once installed, only the thermostat control, supply grille and decorative return air panel of the MPY are visible in the room. The return air panel provides easy access to all internal components. Standard MPY units are constructed with 20 gauge galvanized steel and are provided with a galvanized finish on the cabinet and a powder-coat paint finish on the return air panels.



Modular Hi-Rise Exposed (MXY) 300 CFM to 1200 CFM

The Exposed Modular (MXY) fan coil unit is designed for applications where concealed installation is not possible or practical. The slim, attractively-styled cabinet of the MXY blends with all types of decor. MXY units feature a double-deflection supply grille, an integral return air panel and a unit-mounted thermostat control. Standard MXY units are constructed with 20 gauge galvanized steel and are provided with a powder-coat paint finish.



Modular Hi-Rise Ditto Concealed (MAY/MBY) 300 CFM to 1200 CFM

The Ditto Concealed Modular (MAY/MBY) fan coil system is designed for installations where two units share riser piping in the separation wall between the two rooms but are equipped with individual valves, supply and return grilles, and controls. The Ditto Concealed Modular unit is shipped factory assembled for additional installed cost savings. Standard Ditto units are constructed with 20 gauge galvanized steel and are provided with a galvanized finish on the cabinet and a powder-coat paint finish on the return air panels.

Modular Hi-Rise Concealed Primary/Secondary (MMY/MSY) 300 CFM to 1200 CFM

The Primary/Secondary Modular (MMY/MSY) fan coil unit is ideal for applications where design restricts the installation of IEC's Ditto or Siamese Ditto Systems. With this configuration, field brazing is required to complete the piping between two separate Modular Hi-Rise fan coil units. Standard MMY/MSY units are constructed with 20 gauge galvanized steel and are provided with a galvanized finish on the cabinet and a powder-coat paint finish on the return air panel.

Features and Benefits

Versatility in Design and Installation

Modular Hi-Rise fan coil systems offer versatile unit arrangements made possible as a factory assembled and integrated package. They are designed to be of low visual impact in the room, often positioned in a corner, along the perimeter wall or as part of a partition separating two areas. They can also stand alone in an exposed configuration.

Hi-Rise fan coils are part of a partition separating two areas. The Ditto consists of two units complete with separate valves and controls, which are shipped factory-assembled with common risers.

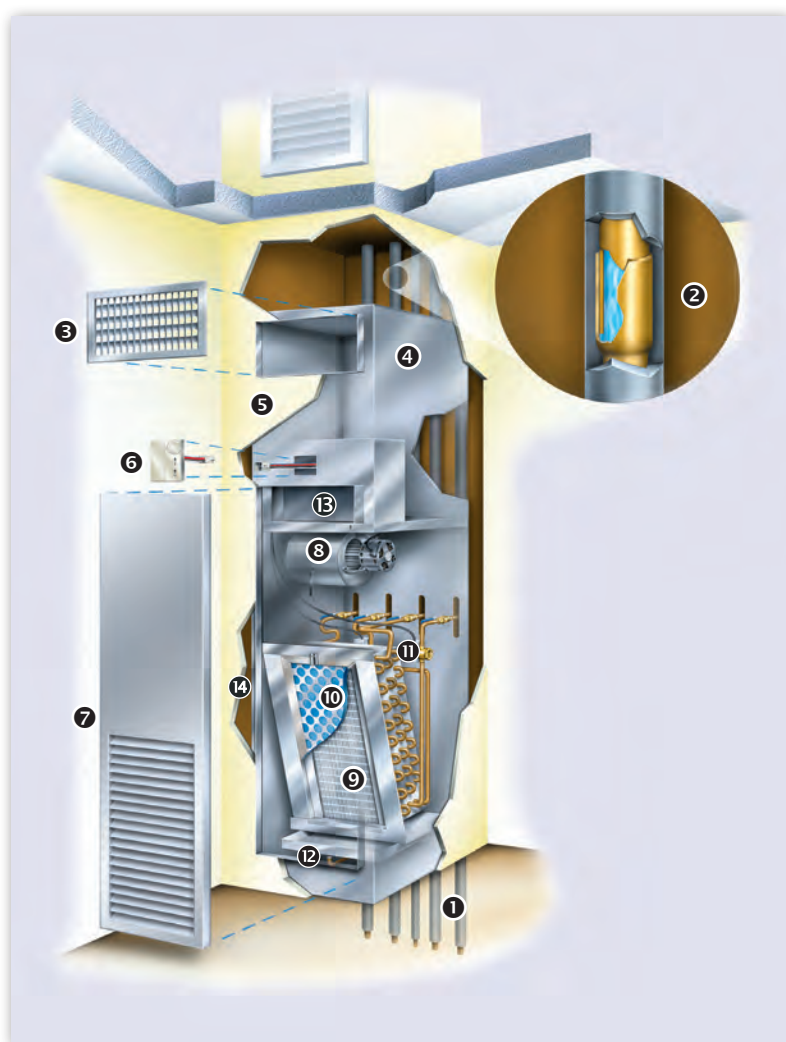

Design Features

- ❶ Field or factory-installed insulated water and condensate risers
- ❷ Swaged riser connection
- ❸ Double-deflection supply air grille
- ❹ 20 gauge galvanized steel cabinet
- ❺ Unit installed behind drywall
- ❻ Thermostat with quick-connect
- ❼ Powder-coat return air access panel
- ❽ Removable motor and blower assembly with quick-connect plug
- ❾ Draw-through, 4-pipe coil*
- ❿ Filter
- ⓫ Factory-installed control valves with quick-connect actuators
- ⓬ Insulated drain pan with p-trap
- ⓭ Control box with cover
- ⓮ Removable acoustical service access panel (not shown)

* Available applications are 2-pipe, 4-pipe (shown), 2-pipe auxiliary electric heat, and 2-pipe total electric heat.

Features and Benefits, Cont'd.

Application Fit

- Exposed and concealed cabinets with 45 possible airflow configurations provide solutions for multiple applications.
- A variety of aesthetically pleasing return and supply grilles will blend with most décors.
- Thermostats are available as unit, surface, wall or ADA mounted for ease of human interface.
- Units are specifically designed for quiet operation.

Design Flexibility

- Easy to use computer rating program to speed up project design.
- Wide variety of coil configurations to match the heating and cooling loads of the space. Coils with different pressure drops to meet the needs of custom applications are also available.
- Standard motor/blower assemblies to meet the needs of applications where duct work is required.
- Customizable cabinetry is available for special applications. Ideal for new construction and renovation projects.
- Optional Ditto fan coil designed to serve two separate rooms using UL listed one-hour fire-rated riser chase.
- Multiple riser locations for total flexibility.
- Wide variety of valve packages factory installed to meet desired control specifications.
- Manual or motorized outside air dampers are available to meet ventilation requirements and reduce field labor.
- Several MERV rated filter media available to address IAQ requirements.
- Extensive offering of control options available.
- Wide variety of insulation material available to address IAQ concerns.
- Stainless steel drain pan with pre-formed rubber p-trap.

Ease of Installation

- Units assembled at the factory in coordination with the job site construction schedule.
- Riser length is matched to the job specifications and pre-fabricated with the specified material. Risers are factory installed or shipped separately.
- Risers swaged to reduce field brazing labor and to ensure the integrity of the connections.
- Drywall can be applied directly to the surface of the concealed unit with factory provided duct collars and drywall stops to ensure a high quality finished appearance.
- Control box at eye level for ease of field wiring and easy access.

Ease of Service

- Filters are easily accessible by removing return air panel.
- Motor and blower are removable with quick-connect plug.
- Control box is easily accessible and at eye level.

Quality and Safety

- Every unit tested and inspected at the factory for trouble free start-up.
- ETL listed.
- AHRI certified.

Product Application

Versatile Unit Arrangement Options

One of the unique traits of the Modular Hi-Rise fan coil system is the versatile unit arrangements possible with this factory-assembled, integrated package. When selecting the best unit design configuration for your specific single- or multi-story building, you are afforded the luxury of choosing from numerous unit arrangement options which achieve maximum efficiency while conserving floor space and reducing installation costs.

Modular Hi-Rise fan coils are designed to be unobtrusive in the room and, thus, are often positioned in a corner, along a perimeter wall, as part of a partition separating two areas, or as a stand-alone unit in the exposed configuration. Modular Hi-Rise fan coils can be specified with up to three side-discharge openings as well as a top discharge for ducted applications.

Below are a few of the many arrangement possibilities of the Modular Hi-Rise fan coil system.

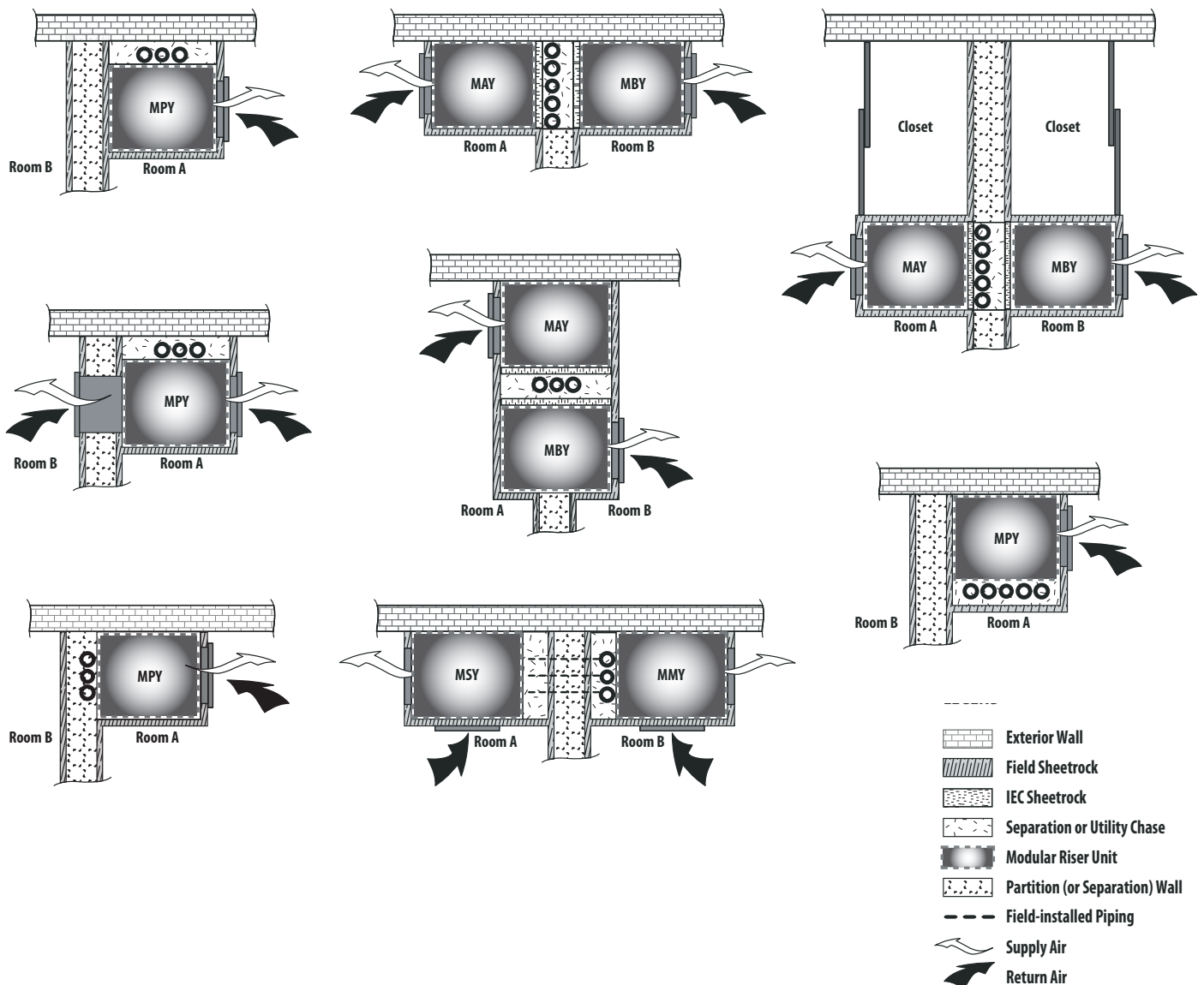

Product Application, Cont'd.

Single-side Supply

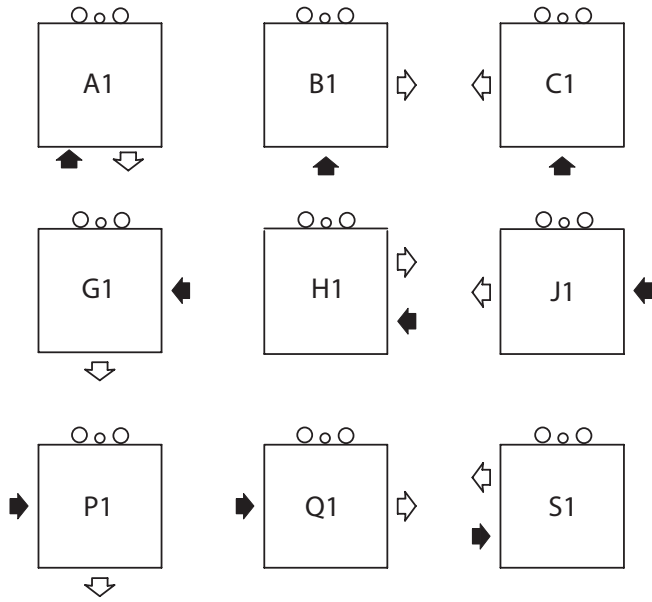

Double-side Supply

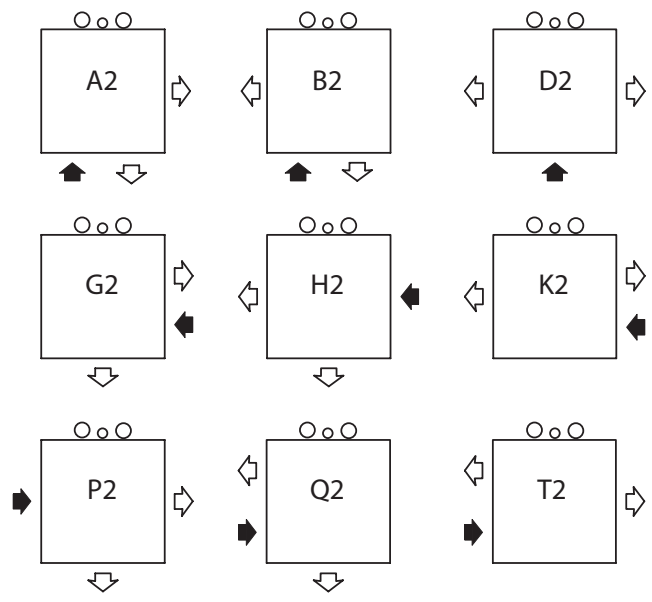

Top with One-side Supply

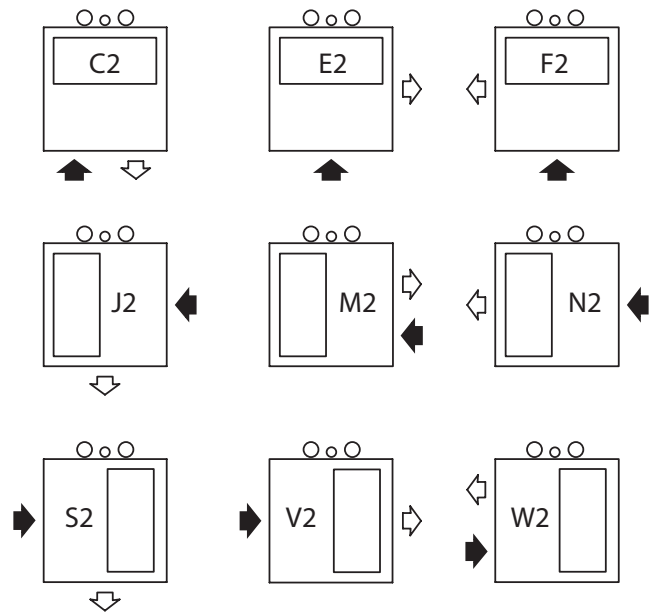

Top with Two-side Supply

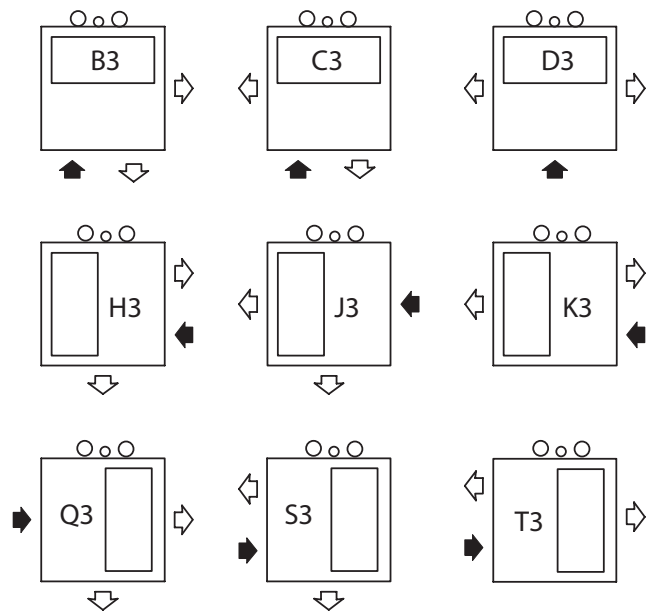

Product Application, Cont'd.

Top Supply Only

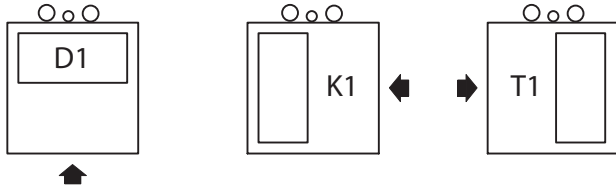

Three-side Supply

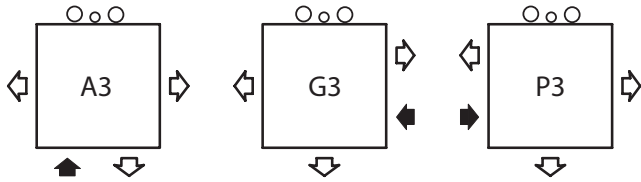

Top with Three-side Supply

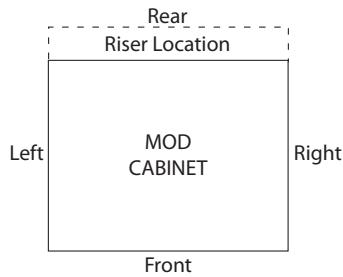
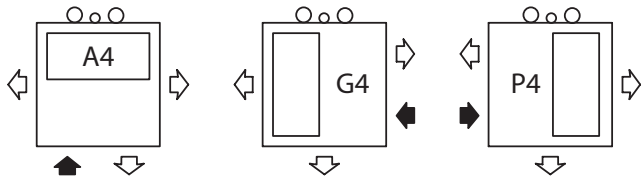

Legend:

➡ Return
⇨ Supply



R = Return
D = Drain
S = Supply

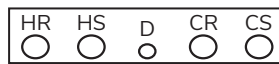

HR = Hot Water Return
HS = Hot Water Supply
D = Drain
CR = Cold Water Return
CS = Cold Water Supply

- NOTES:**
1. The risers (or riser chase) always determines the rear of the unit. The return air/access panel may then be on the left, right or front of the cabinet (as determined by project requirements).
 2. MXY models are available with front return air only.

Product Application, Cont'd.

Riser Material, Sizing & Insulation

Because Modular Hi-Rise units are furnished with field or factory installed risers, the riser type, size and length, and insulation for each unit must be determined based on the position of the unit in the building. The chilled and hot water risers and condensate drain are available in a variety of diameters from 3/4" to 4". All factory furnished risers and riser extensions, including condensate drains, are insulated for the full riser length to eliminate the need for field furnished insulation. Other materials to accommodate such critical specifications as riser expansion and between-the-floor fire proofing must be field furnished and installed by others. Consult the factory for special Applications.

Riser sizing is normally based on the water flow requirements of each unit and the units above and below the unit in the riser column depending on the type of system being used. A common design criteria is to select the risers to limit water velocity at four to seven feet per second. Using this method, risers may be reduced in size as the water flow reduces from floor to floor. Uniform riser sizing may be used on shorter buildings where the additional riser expense would likely be offset by a greater savings in unit handling expense on the job.

Riser Expansion

IEC's Modular Hi-Rise units are built to accommodate modest expansion of the external risers. Standard unit construction, including internal expansion loops, allows for a maximum of $\pm 3/4$ -inch of external riser expansion/contraction. This only allows for expansion between the unit and the riser. This allowance for the movement by the internal piping structure is not intended to replace necessary expansion compensation devices that the

THERMAL EXPANSION OF COPPER RISERS

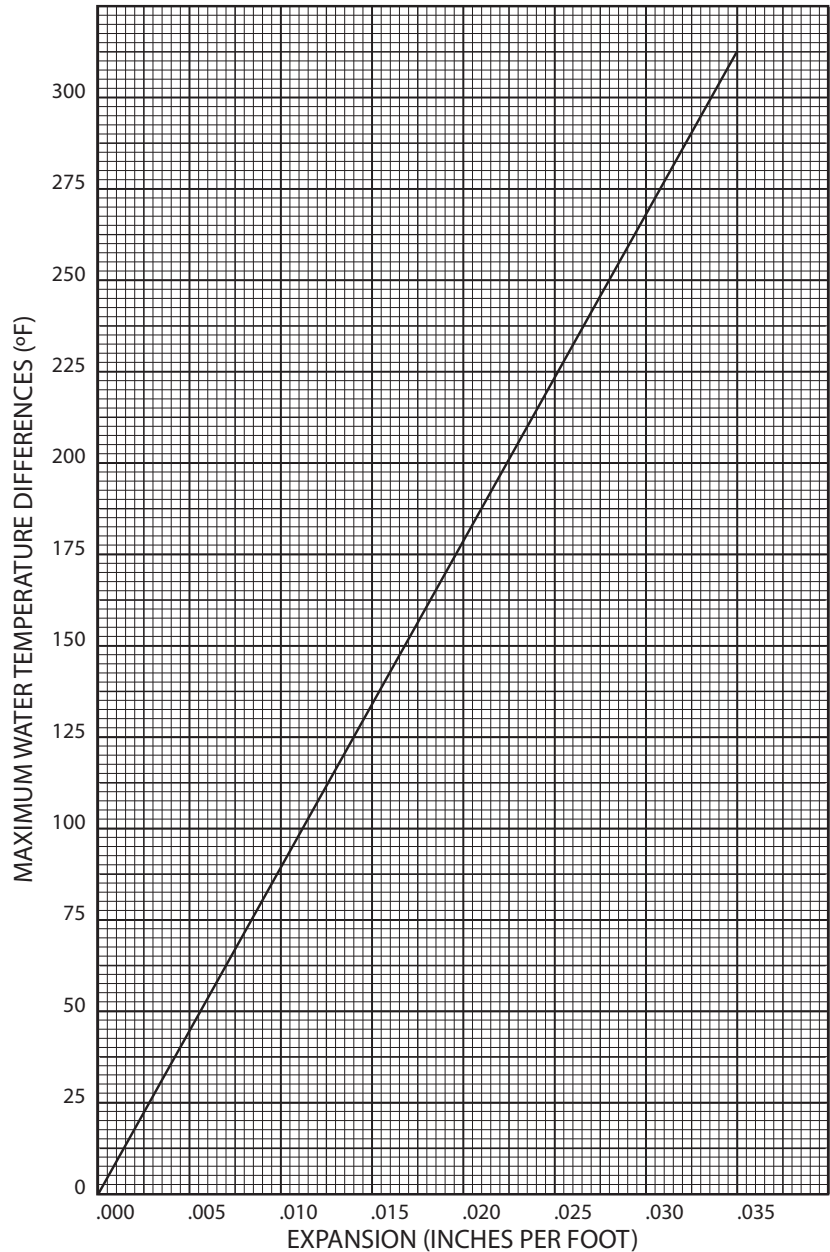

consulting engineer may deem advisable for the external riser system. External riser expansion/contraction compensation and anchoring are the responsibility of the consulting engineer and the installing contractor.

Product Application, Cont'd.

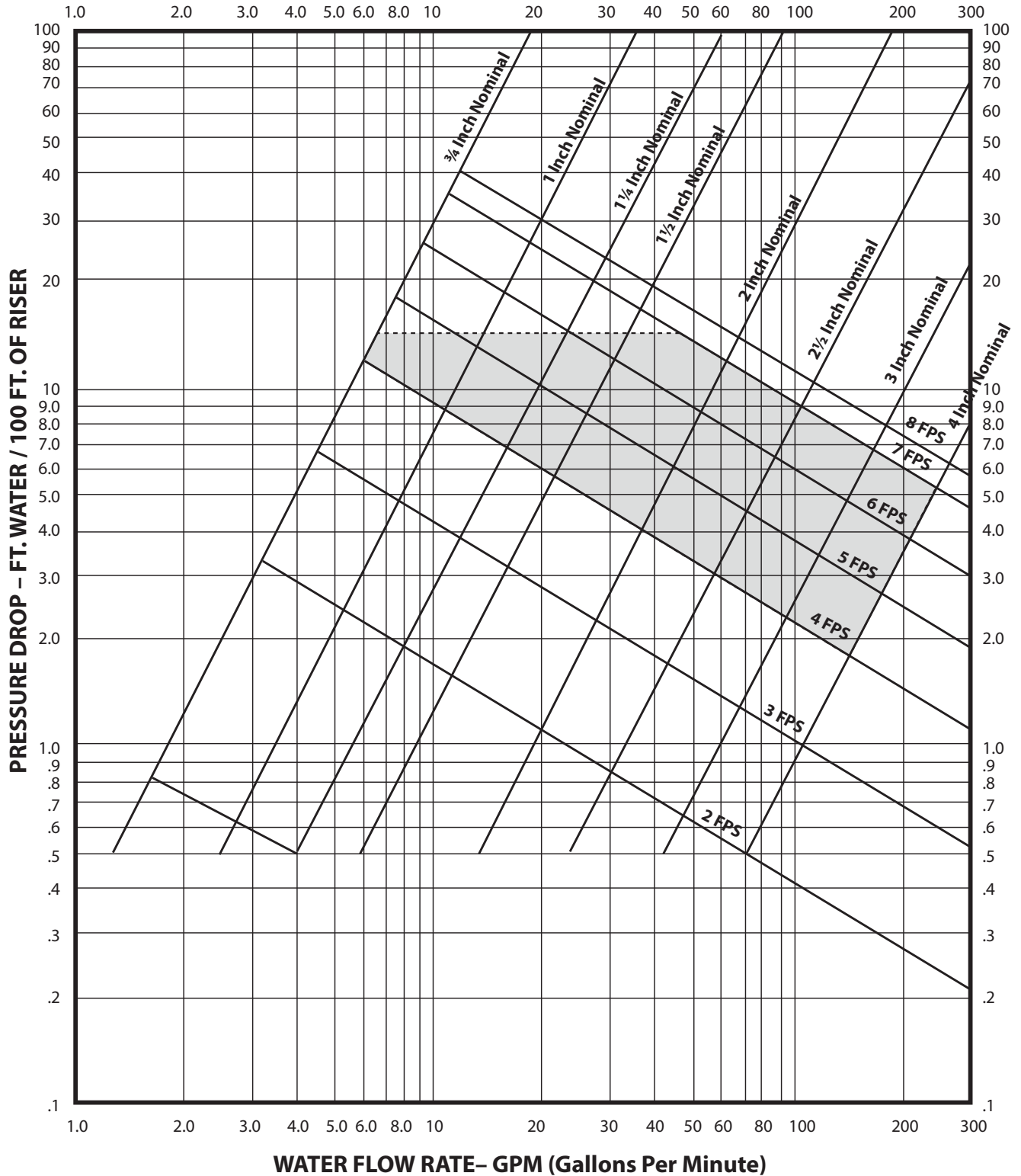

Modular Hi-Rise Series

FAN COIL TECHNICAL CATALOG

Unit Model Key

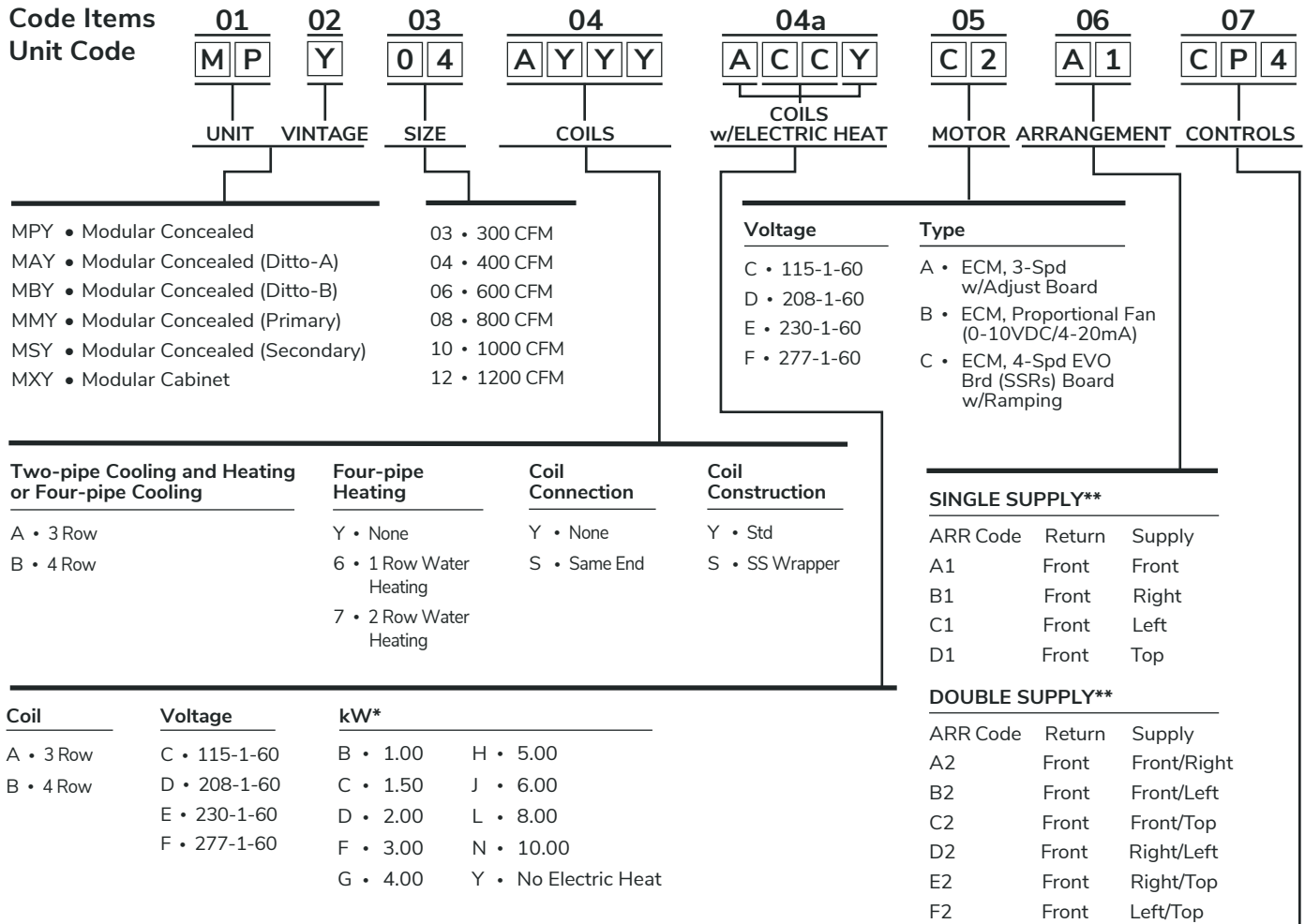

Voltage

B • 24V
C • 120V
D • 208V
E • 240V
F • 277V

System/Thermostat

Manual Fan Operation

A1 • Standard Unit Mount (Switch Only)

Function Control

G • 2-Pipe Heat Only
H • 2-Pipe Cool Only
J • 2-Pipe Heat and Cool, MCO
K • 2-Pipe Heat and Cool, ACO
L • 2-Pipe Heat and Cool w/Aux. Elec. Heat, MCO
M • 2-Pipe Heat and Cool w/Aux. Elec. Heat, ACO
N • 2-Pipe Cool w/Total Elec. Heat, MCO
P • 2-Pipe Cool w/Total Elec. Heat, ACO
Q • 4-Pipe Heat and Cool, MCO
R • 4-Pipe Heat and Cool, ACO

Thermostat

P • Basic 24V Digital, 7-Day Programmable
N • Basic 24V Digital, Non-Programmable
F • Premium 24V Digital, 7-Day Programmable/
BACnet with Proportional Fan/ Valves Option
G • Premium 24V Digital BACnet with
Proportional Fan/ Valves Option
W • Venture 24V Wi-Fi Programmable

* Note that kW's depend on voltage and unit size.

** For additional codes check the price sheet.

*** Consult factory for pricing.

Ratings & Listings

AHRI Certification

IEC's Modular Hi-Rise Series units are certified in compliance with Air-Conditioning, Heating, and Refrigeration Institute (AHRI) industry standard AHRI-440 for room fan coil units. Approved standard ratings are tabulated below.



C-ETL-US Listing

IEC's Modular Hi-Rise Series units are listed by ETL. The C-ETL-US listing signifies that IEC's fan coil units have been examined by ETL and are in compliance with both the U.S. and Canadian applicable standards.

Thermal Overload Protection

All EC motors furnished by IEC contain internal thermal overload protection. The overload automatically resets when the temperature returns to a safe limit. Underwriters Laboratories Inc. approves the motor and thermal overload combination at locked rotor conditions only.

Table 1. EC Motor Standard Ratings

Model	Size	Coil Rows	Air Flow Rating (SCFM)	Water Pressure Drop (ft. water)	Total Cap. (Btuh)	Sensible Cap. (Btuh)	Power Input (Watts)
MAY, MBY, MMY, MSY	03	3	360	28.0	11,500	7,000	85
	03	4	360	6.3	12,200	7,300	85
	04	3	440	35.2	13,600	9,000	115
	04	4	430	10.5	15,600	9,600	115
	06	3	590	15.6	21,900	14,000	135
	06	4	590	34.3	26,000	15,300	135
	08	3	800	25.0	27,500	17,800	250
	08	4	800	40.4	31,400	19,500	250
	10	3	1,050	20.3	37,700	24,500	325
	10	4	1,000	18.6	42,200	25,600	325
	12	3	1,250	18.9	43,100	28,400	440
	12	4	1,240	17.3	46,500	30,500	440
MPY, MAY, MBY, MMY, MSY	12	5	1,200	38.0	48,000	31,000	440
MPY	03	3	360	6.0	11,500	7,000	75
	03	4	360	12.0	12,200	7,300	85
	04	3	430	10.0	13,600	9,000	105
	04	4	420	15.0	15,600	9,600	105
	06	3	590	15.6	21,900	14,000	70
	06	4	590	20.0	25,400	15,300	90
	08	3	800	17.0	27,500	17,800	165
	08	4	800	28.0	31,400	19,500	175
	10	3	1,050	25.0	37,700	24,500	300
	10	4	1,000	20.0	42,200	25,600	345
	12	3	1,250	32.0	43,100	28,400	400
	12	4	1,240	30.0	46,500	30,500	455
MXY	03	3	345	7.0	10,700	7,000	85
	03	4	345	10.0	12,200	7,300	85
	04	3	430	10.0	13,400	8,900	115
	04	4	430	10.5	15,600	9,600	115
	06	3	590	15.6	19,500	12,500	135
	06	4	590	15.0	23,900	14,900	135
	08	3	800	15.0	25,300	17,100	185
	08	4	800	25.0	31,400	19,500	250
	10	3	1,000	25.0	37,700	24,500	325
	10	4	1,000	20.0	42,000	25,600	325
	12	3	1,150	28.0	42,700	28,400	465
	12	4	1,100	25.0	46,500	30,500	440
12	5	1,150	33.0	48,000	31,000	475	

- NOTES: 1. Ratings are based on 80° F DB and 67° F WB EAT, 45° F EWT, 10° F water temperature rise, high fan speed, motor voltage 115/1/60, and airflow under dry coil conditions.
 2. Ratings shown for Ditto, Siamese Ditto and Primary/Secondary configurations are for each unit in the two-unit system.
 3. For all application ratings, use IEC's computer selection program, the quick-selection ratings provided in this catalog, or contact your local IEC representative.
 4. For additional information, please consult AHRI's website at www.ahrinet.org.

Modular Hi-Rise Series

FAN COIL TECHNICAL CATALOG

Ratings and Listings, Cont'd.

Table 2. Hydronic Heat Base Capacity

Rows	EWT	Unit Coil Size	GPM						
			0.5	1.0	2.0	3.0	4.0	6.0	8.0
1-Row	160°F	03	11.3	14.0	15.8	16.5	-	-	-
		04	11.5	14.4	16.3	17.1	-	-	-
		06	-	19.8	23.3	24.7	25.4	-	-
		08	-	20.1	23.9	25.4	26.2	-	-
		10	-	25.2	31.1	33.6	34.9	-	-
		12	-	25.4	31.6	34.1	35.5	-	-
2-Row	160°F	03	15.9	21.0	24.2	-	-	-	-
		04	16.2	21.8	25.6	27.0	-	-	-
		06	-	27.2	35.5	37.4	39.0	-	-
		08	-	28.0	36.1	39.5	41.1	-	-
		10	-	33.2	45.5	50.8	53.8	56.9	-
		12	-	33.7	46.6	52.5	55.8	59.3	61.2
3-Row	140°F	03	14.3	20.0	23.5	24.8	-	-	-
		04	14.6	20.8	25.0	26.5	-	-	-
		06	-	25.1	32.9	36.0	37.7	-	-
		08	-	25.7	34.6	38.3	40.3	-	-
		10	-	-	41.7	47.8	51.1	54.6	-
		12	-	-	42.9	49.7	53.5	57.7	-
4-Row	140°F	03	-	21.0	25.1	-	-	-	-
		04	-	22.0	27.1	28.9	-	-	-
		06	-	27.6	36.9	40.4	42.1	-	-
		08	-	28.4	39.3	43.7	46.0	-	-
		10	-	-	-	53.1	57.1	61.2	63.3
		12	-	-	-	55.7	60.5	65.5	68.1

- NOTES: 1. All base hot water capacities are given in thousands of BTUH (MHB).
 2. Ratings are based on nominal CFM at 70°F EAT and 160°F EWT.
 3. For information regarding performance at specific conditions, please use the IEC rating program or consult your IEC representative for assistance.

Fan Curves – MPY, MMY, MSY, MAY, MBY

NOTE: Supply air grille return air panel and factory-installed throwaway air filter static pressure losses are included in all fan performance curves for all sizes.

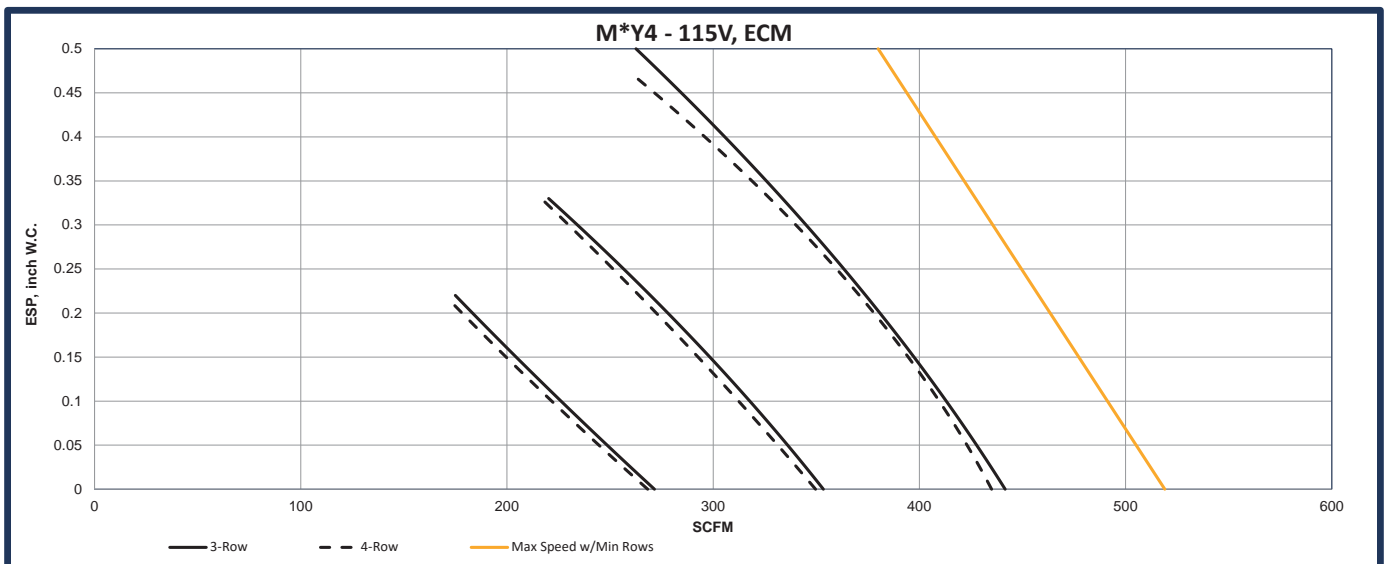
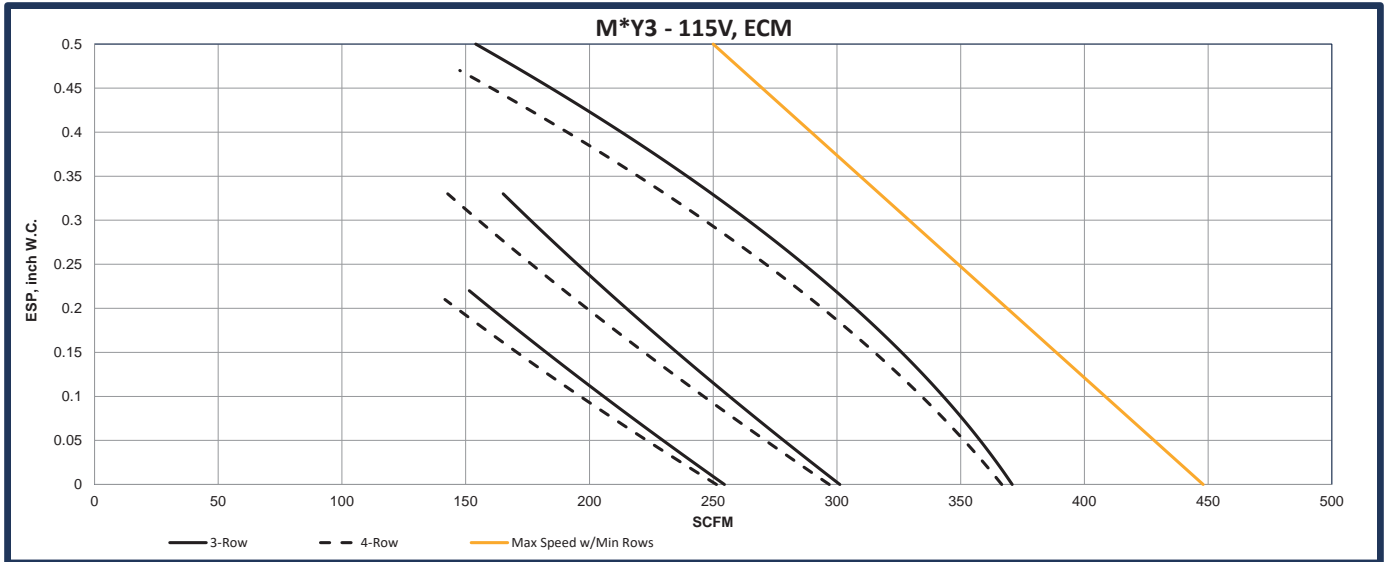

Fan Curves – MPY, MMY, MSY, MAY, MBY, Cont'd.

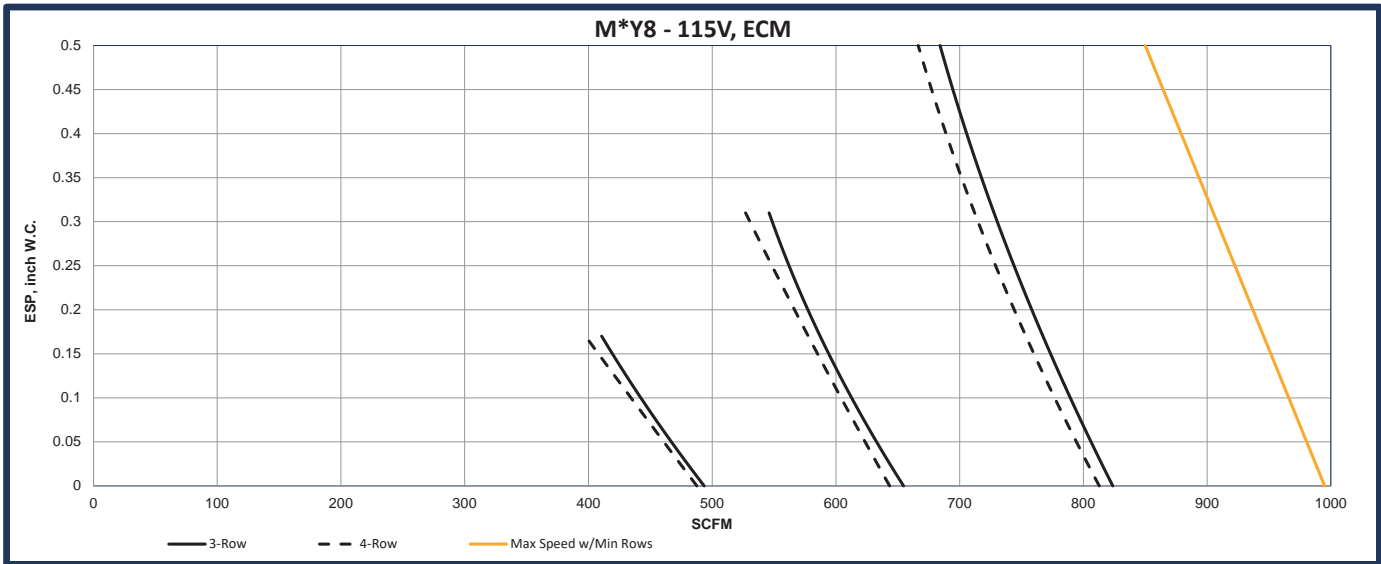
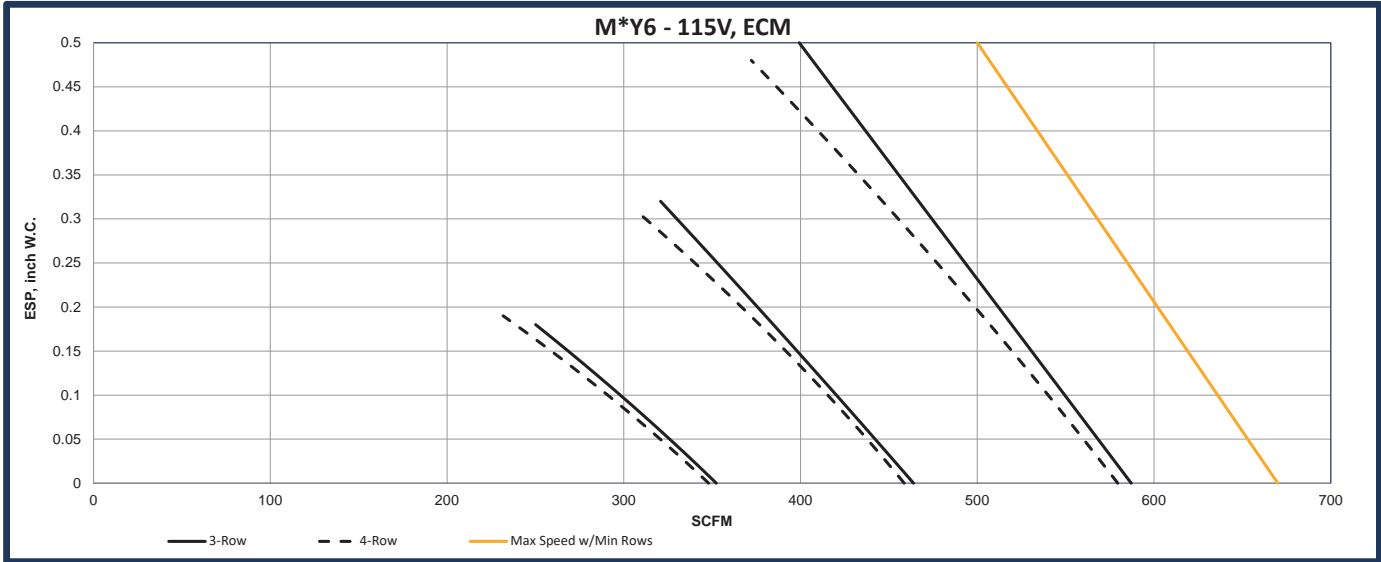

Fan Curves – MPY, MMY, MSY, MAY, MBY, Cont'd.

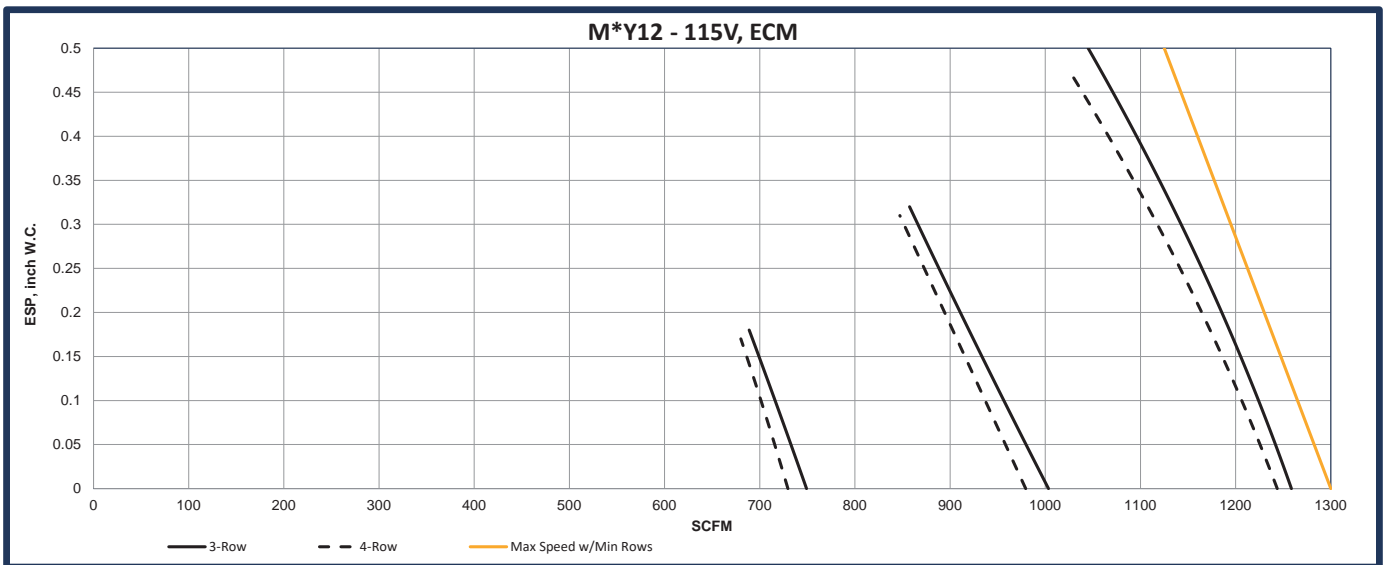
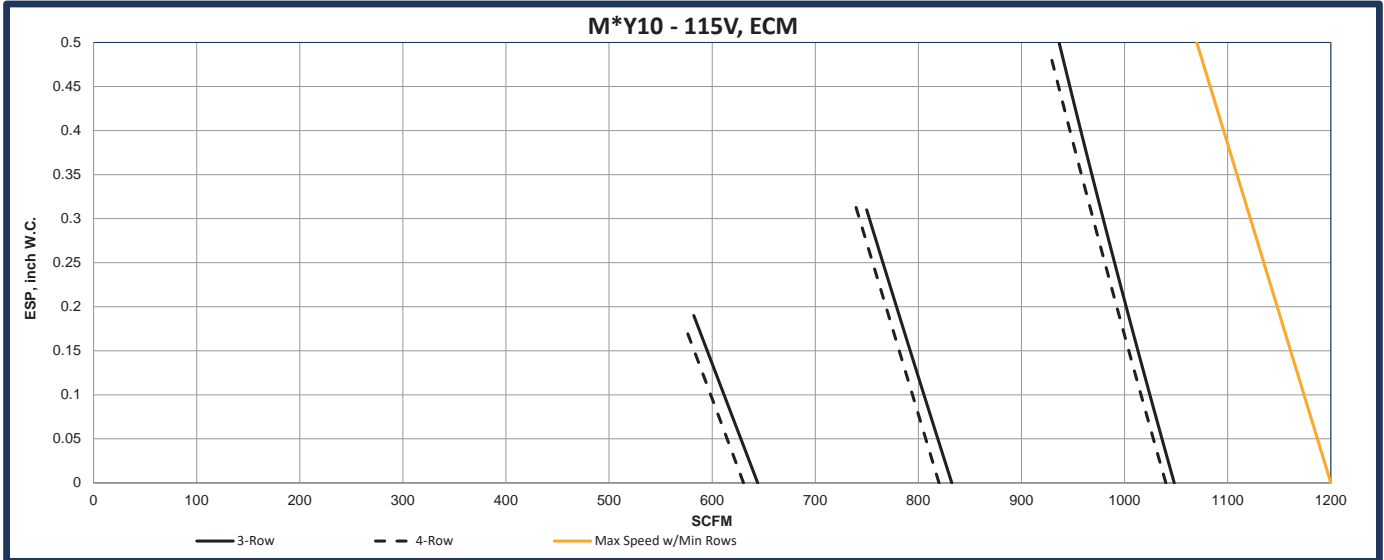

Modular Hi-Rise Series

FAN COIL TECHNICAL CATALOG

Motor Performance Data

Table 3. EC Motor Performance Data – MPY, MAY/MBY, MMY/MSY, MXY

Voltage	Fan Speed	Unit Size	03	04	06	08	10	12
		Nominal HP	1/4	1/4	1/4	1/2	1/2	1/2
115V 60HZ 1-Phase	High	Amps	0.64	0.94	1.60	2.00	3.20	5.21
		Watts	44	68	120	159	257	461
	Medium	Amps	0.43	0.58	0.92	1.18	1.78	2.97
		Watts	28	40	64	89	136	259
	Low	Amps	0.32	0.37	0.54	0.61	0.96	1.4
		Watts	19	23	35	42	69	129
208-240V 60HZ 1-Phase	High	Amps	0.41	0.61	1.02	1.32	1.94	3.27
		Watts	40	67	121	168	253	455
	Medium	Amps	0.30	0.38	0.58	0.79	1.11	1.77
		Watts	25	39	63	96	135	245
	Low	Amps	0.25	0.27	0.34	0.43	0.58	0.83
		Watts	19	23	31	48	65	119
277V 60HZ 1-Phase	High	Amps	0.36	0.51	0.78	1.10	1.57	2.61
		Watts	39	67	116	170	260	447
	Medium	Amps	0.29	0.36	0.49	0.64	0.91	1.42
		Watts	24	39	63	95	143	243
	Low	Amps	0.25	0.27	0.33	0.29	0.45	0.65
		Watts	18	22	34	39	64	110

NOTES: All data is based on 3R/14 fpi dry coil with deco, filter and supply grill @ 0.00"ESP.
These values are based on Broad Ocean EC motors.

Sound Power Data

Table 4. MPY, MAY, MBY, MMY, MSY (AHRI 260)

UNIT SIZE	RATING	FAN SPEED	CFM	SOUND POWER LEVEL, Lw (dB reference one picowatt)							A-wgt (dBA)
				125 Hz	250 Hz	500 Hz	1K Hz	2K Hz	4K Hz	8K Hz	
3	CASING RADIATED w/#1 Style RA Panel & DD Alum. Grille	H	360	61	50	49	40	30	31	37	49
		M	310	57	47	45	36	27	31	37	46
		L	280	55	44	43	33	26	31	37	44
	DUCTED DISCHARGE w/#1 Style RA Panel & DD Alum. Grille	H	360	52	50	42	30	27	31	37	44
		M	310	48	46	38	28	26	31	37	42
		L	280	46	43	36	24	24	30	37	41
4	CASING RADIATED w/#1 Style RA Panel & DD Alum. Grille	H	460	60	53	50	43	35	33	38	51
		M	385	57	50	47	40	31	32	38	48
		L	290	53	46	44	36	28	32	38	45
	DUCTED DISCHARGE w/#1 Style RA Panel & DD Alum. Grille	H	460	54	49	47	40	31	33	37	47
		M	385	52	46	44	37	28	32	37	45
		L	290	49	42	40	33	26	32	38	43
6	CASING RADIATED w/#1 Style RA Panel & DD Alum. Grille	H	580	65	55	50	42	35	33	37	53
		M	500	61	50	47	39	32	32	37	49
		L	400	57	45	43	33	28	31	37	45
	DUCTED DISCHARGE w/#1 Style RA Panel & DD Alum. Grille	H	580	58	55	48	38	33	34	37	50
		M	500	54	51	46	34	30	32	37	47
		L	400	48	44	41	28	26	31	37	42
8	CASING RADIATED w/#1 Style RA Panel & DD Alum. Grille	H	810	70	59	56	51	44	39	38	58
		M	580	63	53	50	44	37	34	38	52
		L	430	56	46	45	37	30	32	38	46
	DUCTED DISCHARGE w/#1 Style RA Panel & DD Alum. Grille	H	810	62	59	54	45	39	37	38	55
		M	580	56	52	47	38	32	33	37	48
		L	430	49	45	41	31	27	31	37	43
10	CASING RADIATED w/#1 Style RA Panel & DD Alum. Grille	H	1045	67	63	59	54	51	46	38	61
		M	930	65	60	57	51	48	42	38	58
		L	670	58	53	50	44	39	33	37	51
	DUCTED DISCHARGE w/#1 Style RA Panel & DD Alum. Grille	H	1045	66	62	57	53	48	44	39	59
		M	930	63	59	55	48	45	41	37	56
		L	670	56	51	47	39	35	32	37	48
12	CASING RADIATED w/#1 Style RA Panel & DD Alum. Grille	H	1145	66	64	59	56	52	47	38	62
		M	950	64	60	57	52	49	42	37	59
		L	805	62	57	55	49	45	38	37	56
	DUCTED DISCHARGE w/#1 Style RA Panel & DD Alum. Grille	H	1095	63	67	57	54	47	44	39	61
		M	950	62	58	55	48	43	40	37	55
		L	805	59	55	51	44	39	36	37	52

- NOTES: 1. Unit Test Configuration: Front Return/ Front Supply, 4 Row, 14 FPI Coil, High Speed, 115 VAC Motor, #1 Return Air Panel, DD Aluminum Grille, 1/2 inch dual density fiberglass insulation.
 2. Casing Radiated Testing per AHRI 260-2001: 4.2.2.3 Casing radiated with free inlet, Sound Rating of Ducted Air Moving and Conditioning Equipment.
 3. Ducted Discharge Testing per AHRI 260-2001: 4.2.2.1 Ducted discharge, Sound Rating of Ducted Air Moving and Conditioning Equipment.
 4. Sound power data is expressed in decibels, dB RE: 1 x 10⁻¹² w (picowatts).

Sound Power Data, Cont'd.

Table 5. MPY, MAY, MBY, MMY, MSY (AHRI 350)

UNIT SIZE	RATING	FAN SPEED	CFM	SOUND POWER LEVEL, L _w (dB reference one picowatt)							A-wgt (dBA)
				125 Hz	250 Hz	500 Hz	1K Hz	2K Hz	4K Hz	8K Hz	
3	CASING RADIATED w/#1 Style RA Panel & DD Alum. Grille	H	360	63	53	50	42	34	33	38	51
		M	310	59	50	47	38	30	32	38	48
		L	280	56	47	45	35	27	32	38	46
4	CASING RADIATED w/#1 Style RA Panel & DD Alum. Grille	H	460	62	56	53	47	39	36	38	54
		M	385	59	52	50	44	35	33	38	51
		L	290	56	49	47	40	30	32	38	47
6	CASING RADIATED w/#1 Style RA Panel & DD Alum. Grille	H	580	69	58	53	46	41	38	37	56
		M	500	65	54	50	43	37	35	36	53
		L	400	59	48	46	37	30	31	36	47
8	CASING RADIATED w/#1 Style RA Panel & DD Alum. Grille	H	810	72	62	59	53	49	45	40	61
		M	580	65	56	53	47	41	37	36	54
		L	430	60	49	47	39	32	31	36	48
10	CASING RADIATED w/#1 Style RA Panel & DD Alum. Grille	H	1035	72	65	62	58	55	51	42	64
		M	820	67	60	57	52	48	44	36	59
		L	590	61	56	51	44	39	33	34	52
12	CASING RADIATED w/#1 Style RA Panel & DD Alum. Grille	H	1145	71	68	63	60	56	53	43	66
		M	950	68	63	61	55	52	48	39	62
		L	805	65	59	58	52	48	43	37	59

- NOTES: 1. Unit Test Configuration: Front Return/ Front Supply, 4 Row, 14 FPI Coil, 0.0 inch ESP @ High Speed, 115 VAC Motor, #1 Return Air Panel, DD Aluminum Grille, 1/2 inch dual density fiberglass insulation.
 2. Casing Radiated Testing per AHRI 350-2001: 4.2.2.3 Casing radiated with free inlet, Sound Rating of Ducted Air Moving and Conditioning Equipment.
 3. Sound power data is expressed in decibels, dB RE: 1 x 10⁻¹² w (picowatts).

Sound Power Data, Cont'd.

Table 6. MXY (AHRI 350)

UNIT SIZE	RATING	FAN SPEED	CFM	SOUND POWER LEVEL, L _w (dB reference one picowatt)							A-wgt (dBA)
				125 Hz	250 Hz	500 Hz	1K Hz	2K Hz	4K Hz	8K Hz	
3	CASING RADIATED w/#1 Style RA Panel & Integral DD Alum. Grille	H	310	64	54	50	43	34	30	31	52
		M	270	58	50	46	39	28	26	30	48
		L	245	58	47	44	35	24	25	30	46
4	CASING RADIATED w/#1 Style RA Panel & DD Alum. Grille	H	420	70	59	55	48	40	39	36	58
		M	360	65	54	51	44	35	33	32	53
		L	275	61	51	47	39	29	28	31	49
6	CASING RADIATED w/#1 Style RA Panel & DD Alum. Grille	H	520	68	57	53	46	41	39	34	56
		M	460	66	53	50	42	37	34	32	53
		L	370	60	48	45	36	30	28	30	47
8	CASING RADIATED w/#1 Style RA Panel & DD Alum. Grille	H	690	72	62	58	53	49	45	41	61
		M	540	67	56	53	47	42	38	33	55
		L	410	61	50	47	40	33	29	30	49
10	CASING RADIATED w/#1 Style RA Panel & DD Alum. Grille	H	995	71	65	62	58	55	51	42	64
		M	790	67	59	58	53	49	44	36	59
		L	570	61	53	51	44	39	34	34	52
12	CASING RADIATED w/#1 Style RA Panel & DD Alum. Grille	H	1070	70	67	63	60	56	52	43	66
		M	915	68	62	61	55	51	47	37	62
		L	795	65	51	57	51	47	42	33	58

- NOTES: 1. Unit Test Configuration: Front Return/ Front Supply, 4 Row, 14 FPI Coil, 115 VAC Motor, #1 Return Air Panel, DD Aluminum Grille, 1/2 inch dual density fiberglass insulation.
 2. Casing Radiated Testing per AHRI 350-2001: 4.2.2.3 Casing radiated with free inlet, Sound Rating of Ducted Air Moving and Conditioning Equipment.
 3. Sound power data is expressed in decibels, dB RE: 1 x 10⁻¹² w (picowatts).

Electric Heating

Electric heaters are available on IEC Modular Hi-Rise Series fan coil units for the following applications.

Total Electric Heat

Total electric heat eliminates the requirement for a boiler. Heating and/or cooling may be available on an individual basis throughout the year. Two-pipe chilled water is used for cooling, and the electric heater is used for heating. Individual room controls can be supplied for either manual or automatic changeover.

Auxiliary Electric Heat

Auxiliary electric heat is ideal for tempering room air between seasons and during the cooling season when chilled water is being circulated. Individual room controls are supplied to provide electric heat only when chilled water is being circulated. During regular heating season, heating is provided by hot water being circulated in the system.

Construction

Heater coils of high-grade resistance wire are supported by ceramic insulators on plated steel brackets. These heating elements are located at the discharge area of the motor/blower. High limit thermal cutouts protect the unit in the event of airflow loss. There are many special applications and control sequences for electric heat. For special applications please consult the factory.

Table 7. Electric Heater Selection

Voltage	kW	Unit Size					
		03	04	06	08	10	12
120V	1.0	•	•	•	•	•	•
	1.5	•	•	•	•	•	•
	2.0	•	•	•	•	•	•
	3.0	•	•	•	•	•	•
208V	1.0	•	•	•	•	•	•
	1.5	•	•	•	•	•	•
	2.0	•	•	•	•	•	•
	3.0	•	•	•	•	•	•
	4.0	–	•	•	•	•	•
	5.0	–	–	•	•	•	•
	6.0	–	–	•	•	•	•
	8.0	–	–	–	•	•	•
240V 277V	1.0	•	•	•	•	•	•
	1.5	•	•	•	•	•	•
	2.0	•	•	•	•	•	•
	3.0	•	•	•	•	•	•
	4.0	–	•	•	•	•	•
	5.0	–	–	•	•	•	•
	6.0	–	–	•	•	•	•
	8.0	–	–	–	•	•	•
	10.0	–	–	–	–	•	•

Submittal Data

MPY – Modular Hi-Rise Concealed

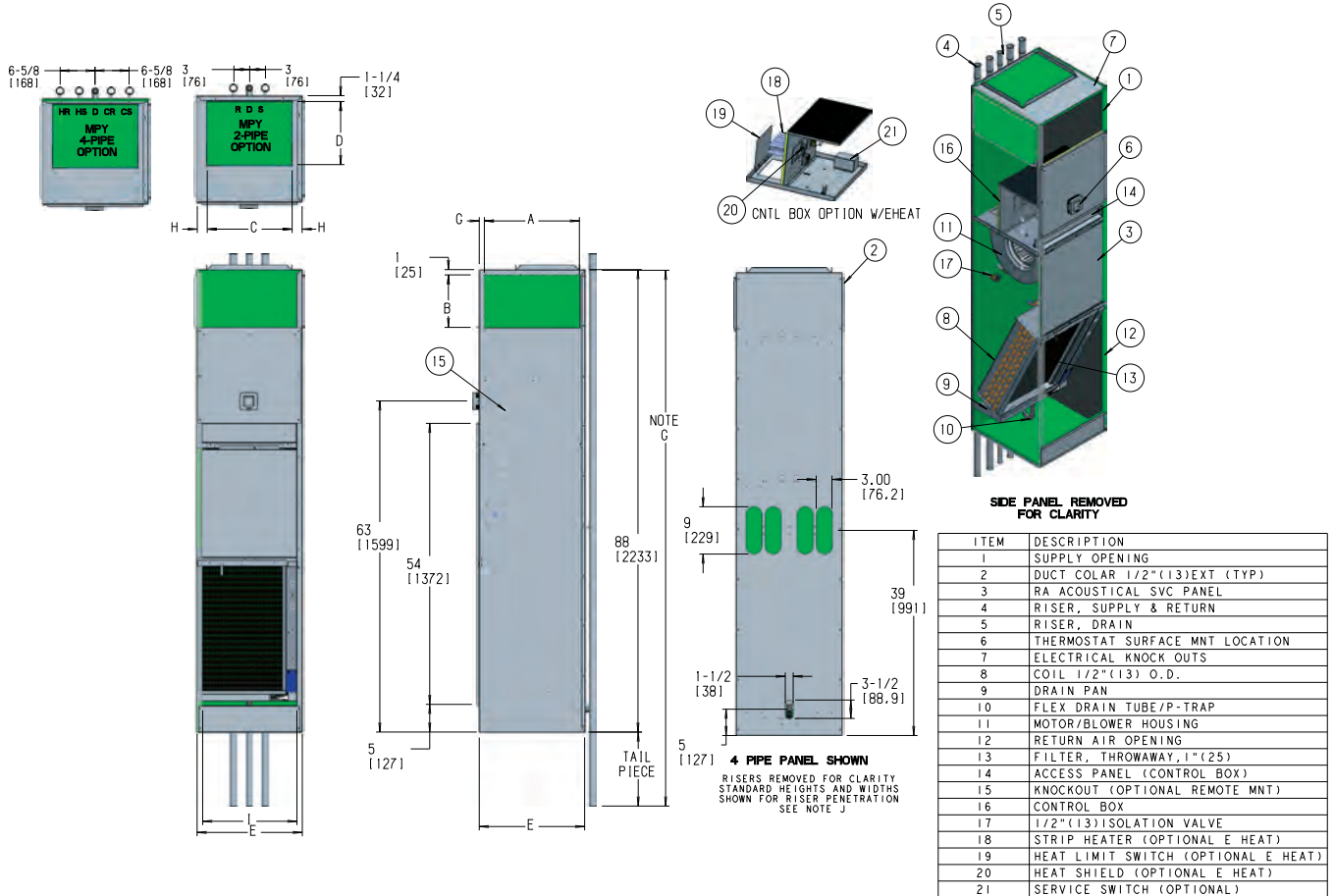

Unit Model	Dimension – Inches (Millimeters)										Unit Weight*
	Single Supply		Double Supply		Top Supply		Dimensions				
	A	B	A	B	C	D	E	G	H	I	
MPY 03	14 (356)	8 (203)	14 (356)	6 (152)	14 (356)	10 (254)	17 (432)	1-1/2 (38)	1-1/2 (38)	14 (356)	180 (82)
MPY 04	14 (356)	12 (305)	14 (356)	6 (152)	14 (356)	10 (254)	17 (432)	1-1/2 (38)	1-1/2 (38)	14 (356)	225 (102)
MPY 06	18 (457)	10 (254)	18 (457)	6 (152)	16 (406)	12 (305)	20 (508)	1 (25)	2 (51)	18 (457)	240 (109)
MPY 08	18 (457)	12 (305)	18 (457)	6 (152)	16 (406)	12 (305)	20 (508)	1 (25)	2 (51)	18 (457)	260 (118)
MPY 10	22 (559)	16 (406)	22 (559)	8 (203)	18 (457)	16 (406)	24 (610)	1 (25)	3 (76)	22 (559)	280 (127)
MPY 12	22 (559)	16 (406)	22 (559)	8 (203)	18 (457)	16 (406)	24 (610)	1 (25)	3 (76)	22 (559)	305 (138)

NOTES: * Unit weights are approximate (shown in pounds and kg) and are based on dry coils, minimum rows and exclude packaging, valves or other components.

- A. Units are fabricated of galvanized steel with a 16 gauge galvanized fan deck.
- B. All risers are insulated.
- C. Thermostats shipped loose for field installation.
- D. Risers are factory piped to coil with valves as specified.
- E. Blower, motor, valves, coil and filter are accessible through the return air opening.
- F. Unit and control box are insulated.
- G. Riser length = [(floor to floor) + 2 inches (51)]. Maximum riser length = 119 inches (3023). Consult riser submittals for specifications.
- H. Maximum riser diameter is 2-1/2 inches (64). If larger diameters are required, consult the factory.
- I. Expansion loops in hot water heating circuits as required.
- J. Slots provided in the back panel for coil connection to permit expansion and contraction of risers. Coil connections to be at the center of the slots.
- K. See unit arrangements for supply and return air orientation.
- L. Dimensions are in inches, dimensions in () are in millimeters.
- M. Riser chase available. See I100-90047874.

Drawing is provided for reference only.
Dimensions may vary with options ordered.
Consult IEC website for submittal drawings.

Modular Hi-Rise Series

FAN COIL TECHNICAL CATALOG

Submittal Data, Cont'd.

MPY/MMY/MSY – Modular Hi-Rise Concealed, Universal Arrangement (U0)

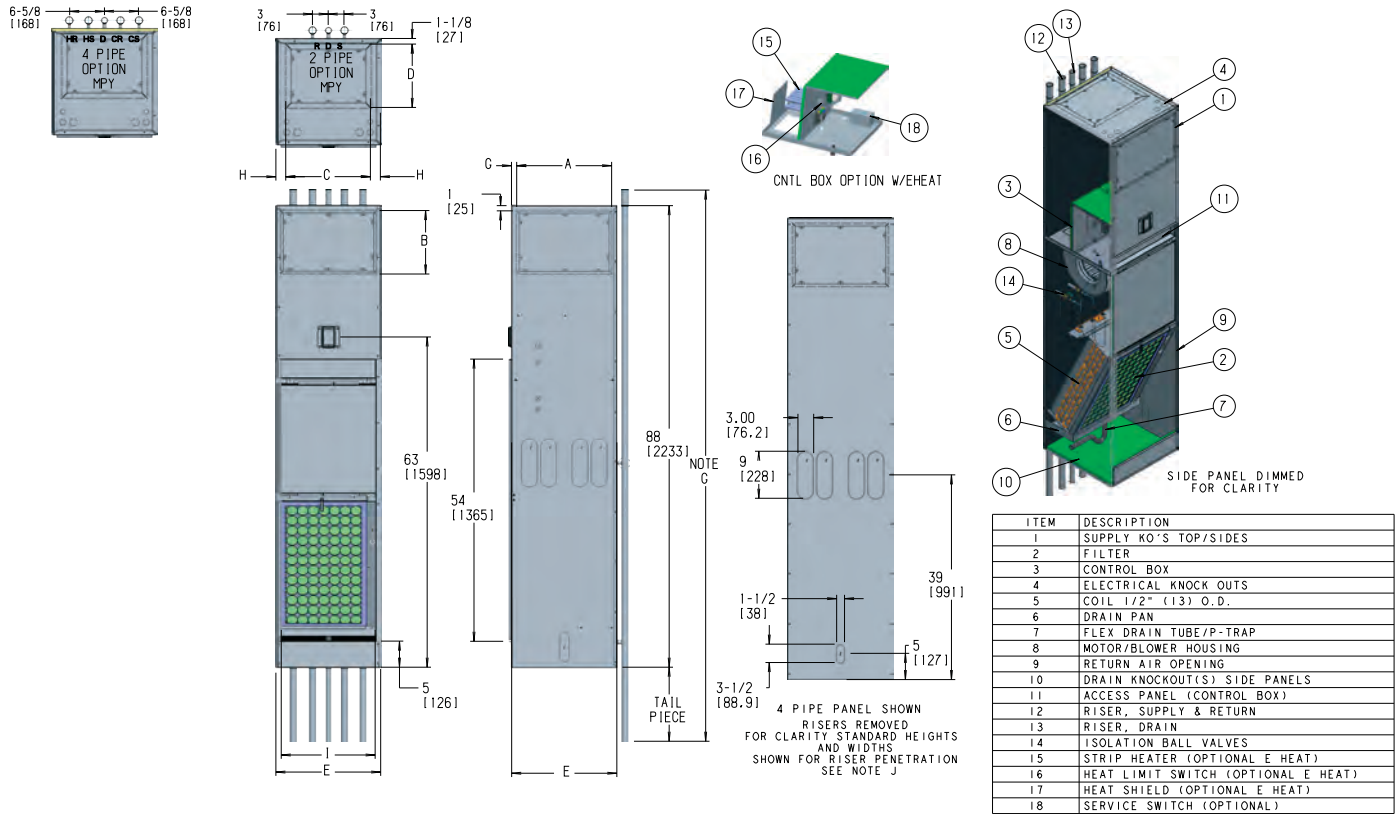

Unit Model	Dimension – Inches (Millimeters)								Unit Weight*
	Side/Front Supply		Top Supply Single		Dimensions				
	A	B	C	D	E	F	H	I	
M*Y 03	14 (356)	12 (305)	14 (356)	10 (254)	17 (432)	1-1/2 (38)	1-1/2 (38)	14 (356)	180 (82)
M*Y 04									225 (102)
M*Y 06	18 (457)	12 (305)	16 (406)	12 (305)	20 (508)	1 (25)	2 (51)	18 (457)	240 (109)
M*Y 08									260 (118)
M*Y 10	22 (559)	16 (406)	18 (457)	16 (406)	24 (610)	1 (25)	3 (76)	22 (559)	280 (127)
M*Y 12									305 (138)

- NOTES: * Unit weights are approximate (shown in pounds and kg) and are based on dry coils, minimum rows and exclude packaging, valves or other components.
- A. Units are fabricated of galvanized steel with a 16 gauge galvanized fan deck.
 - B. All risers are insulated.
 - C. Thermostats shipped loose for field installation.
 - D. Risers are factory piped to coil with valves as specified.
 - E. Blower, motor, valves, coil and filter are accessible through the return air opening.
 - F. Unit and control box are insulated.
 - G. Riser length = [(floor to floor) + 2 inches (51)]. Maximum riser length = 119 inches (3023). Consult riser submittals for specifications.
 - H. Maximum riser diameter is 3 inches (76). If larger diameters are required, consult the factory.
 - I. Expansion loops in hot water heating circuits as required.
 - J. Riser slots knock-outs provided on 3 sides of cabinet for coil connection to permit expansion and contraction of risers. Coil connections to be at the center of the slots.
 - K. Drain knock-outs on 3 sides of cabinet.
 - L. Dimensions are in inches, dimensions in () are in millimeters.
 - M. UO arrangement also available for MMY and MSY models.

Drawing is provided for reference only.
 Dimensions may vary with options ordered.
 Consult IEC website for submittal drawings.

Submittal Data, Cont'd.

MAY/MBY – Modular Hi-Rise Ditto, Concealed (UL-1 Hr. Fire-Rated)

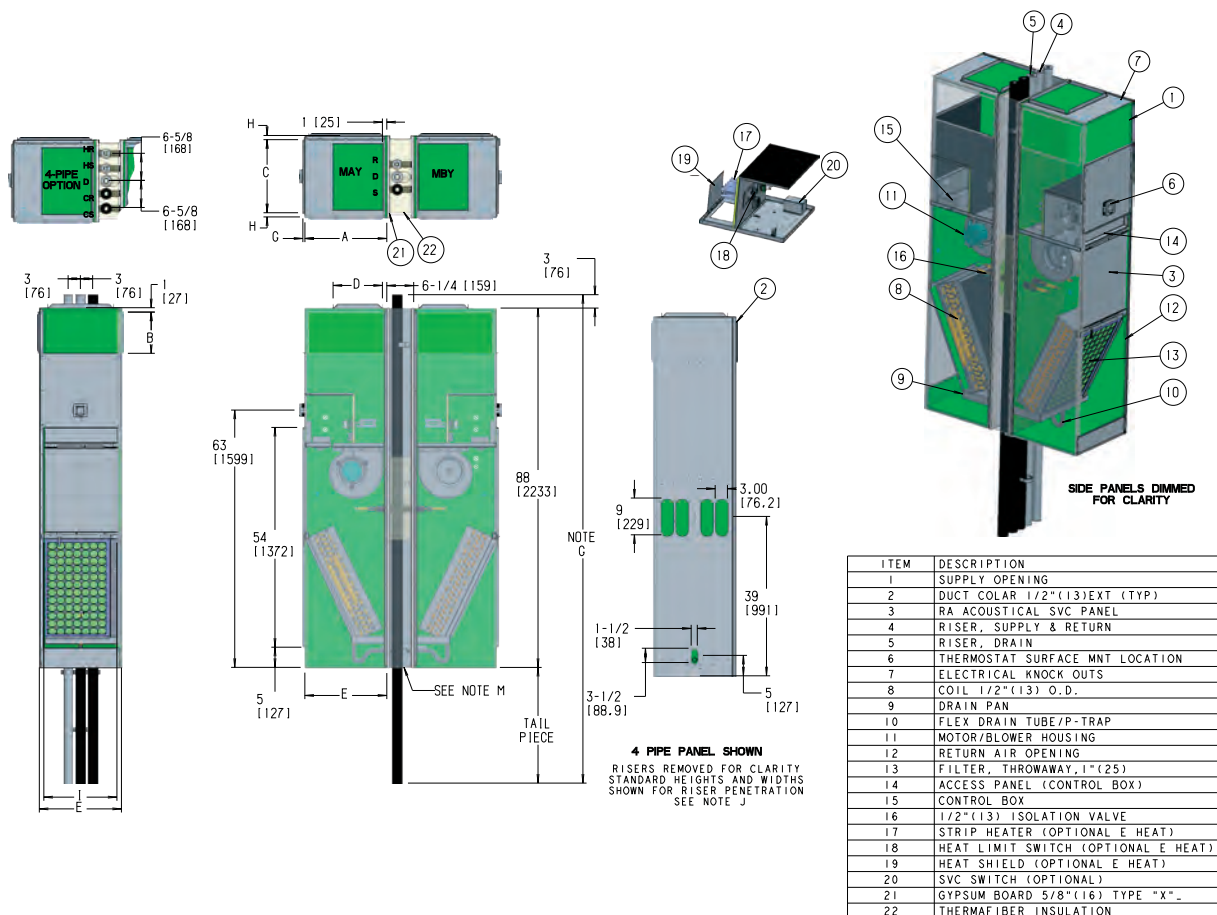

Unit Model	Dimension – Inches (Millimeters)											Unit Weight*
	Single Supply		Double Supply		Top Supply		Dimensions					
	A	B	A	B	C	D	E	G	H	I	J	
MAY/MBY 03	14 (356)	8 (203)	14 (356)	6 (152)	14 (356)	10 (254)	17 (432)	1-1/2 (38)	1-1/2 (38)	14 (356)	40-1/4 (1022)	360 (163)
MAY/MBY 04	14 (356)	12 (305)	14 (356)	6 (152)	14 (356)	10 (254)	17 (432)	1-1/2 (38)	1-1/2 (38)	14 (356)	40-1/4 (1022)	450 (204)
MAY/MBY 06	18 (457)	10 (254)	18 (457)	6 (152)	16 (406)	12 (305)	20 (508)	1 (25)	2 (51)	18 (457)	46-1/4 (1175)	480 (217)
MAY/MBY 08	18 (457)	12 (305)	18 (457)	6 (152)	16 (406)	12 (305)	20 (508)	1 (25)	2 (51)	18 (457)	46-1/4 (1175)	520 (236)
MAY/MBY 10	22 (559)	16 (406)	22 (559)	8 (203)	18 (457)	16 (406)	24 (610)	1 (25)	3 (76)	22 (559)	54-1/4 (1378)	560 (254)
MAY/MBY 12	22 (559)	16 (406)	22 (559)	8 (203)	18 (457)	16 (406)	24 (610)	1 (25)	3 (76)	22 (559)	54-1/4 (1378)	610 (276)

NOTES: * Unit weights are approximate (shown in pounds and kg) and are based on dry coils, minimum rows and exclude packaging, valves or other components.

- A. Units are fabricated of galvanized steel with a 16 gauge galvanized fan deck.
- B. All risers are insulated.
- C. Thermostats shipped loose for field installation.
- D. Risers are factory piped to coil with valves as specified.
- E. Blower, motor, valves, coil and filter are accessible through the return air opening.
- F. Unit and control box are insulated.
- G. Riser length = [(floor to floor) + 2 inches (51)]. Maximum riser length is 119 inches (3023). Consult riser submittals for specifications.
- H. Maximum riser diameter is 2-1/2 inches (64). If larger diameters are required, consult the factory.
- I. Expansion loops in hot water heating circuits as required.
- J. Slots provided in the back panel for coil connection to permit expansion and contraction of risers. Coil connections to be at the center of the slots.
- K. See unit arrangements for supply and return air orientation.
- L. Dimensions are in inches, dimensions in () are in millimeters.
- M. 18 gauge riser chase.

Drawing is provided for reference only.
Dimensions may vary with options ordered.
Consult IEC website for submittal drawings.

Modular Hi-Rise Series

FAN COIL TECHNICAL CATALOG

Submittal Data, Cont'd.

MMY – Modular Hi-Rise Concealed (Primary)

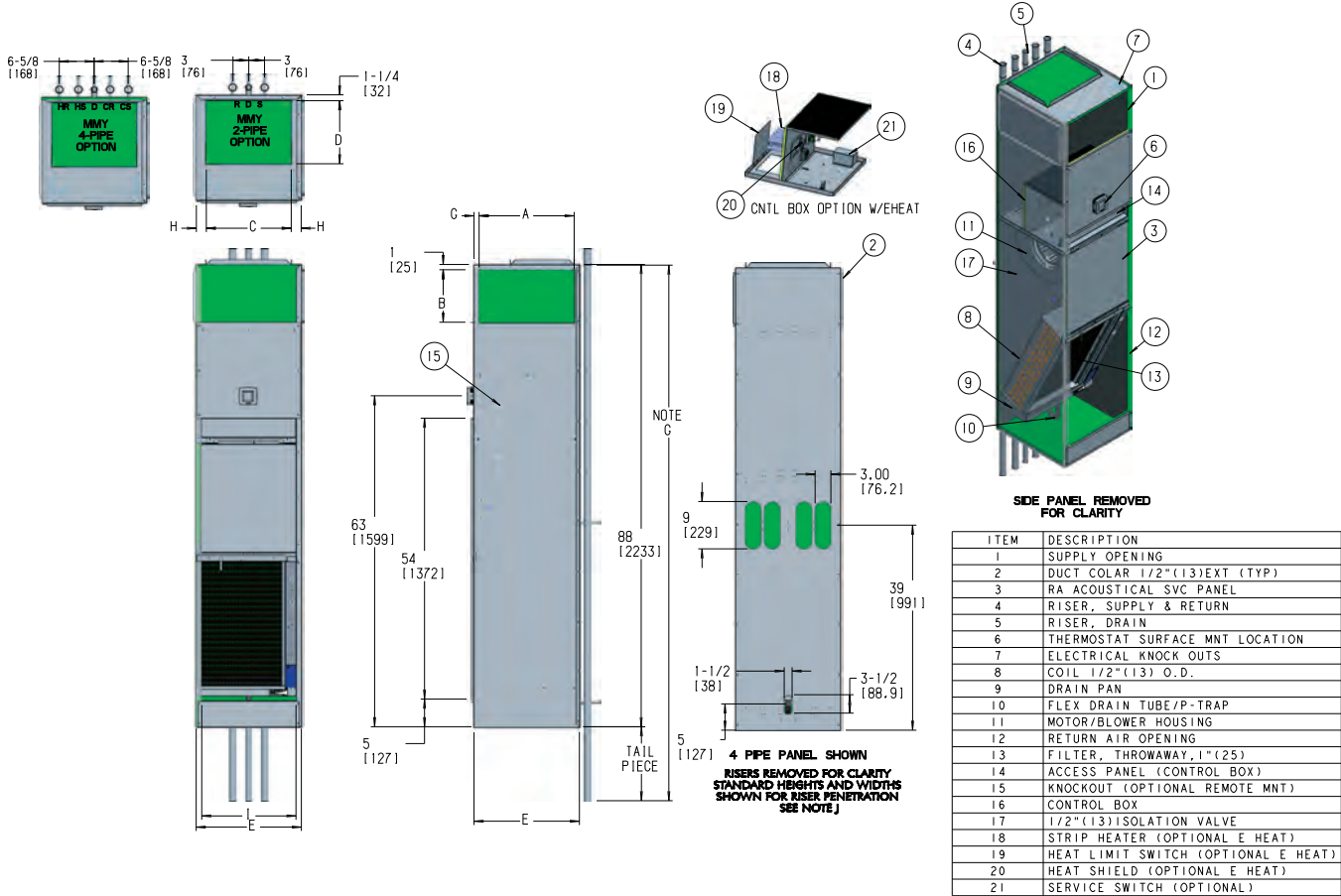

Unit Model	Dimension – Inches (Millimeters)										Unit Weight*
	Single Supply		Double Supply		Top Supply		Dimensions				
	A	B	A	B	C	D	E	G	H	I	
MMY 03	14 (356)	8 (203)	14 (356)	6 (152)	14 (356)	10 (254)	17 (432)	1-1/2 (38)	1-1/2 (38)	14 (356)	180 (82)
MMY 04	14 (356)	12 (305)	14 (356)	6 (152)	14 (356)	10 (254)	17 (432)	1-1/2 (38)	1-1/2 (38)	14 (356)	225 (102)
MMY 06	18 (457)	10 (254)	18 (457)	6 (152)	16 (406)	12 (305)	20 (508)	1 (25)	2 (51)	18 (457)	240 (109)
MMY 08	18 (457)	12 (305)	18 (457)	6 (152)	16 (406)	12 (305)	20 (508)	1 (25)	2 (51)	18 (457)	260 (118)
MMY 10	22 (559)	16 (406)	22 (559)	8 (203)	18 (457)	16 (406)	24 (610)	1 (25)	3 (76)	22 (559)	280 (127)
MMY 12	22 (559)	16 (406)	22 (559)	8 (203)	18 (457)	16 (406)	24 (610)	1 (25)	3 (76)	22 (559)	305 (138)

- NOTES:**
- * Unit weights are approximate (shown in pounds and kg) and are based on dry coils, minimum rows and exclude packaging, valves or other components.
 - A. Units are fabricated of galvanized steel with a 16 gauge galvanized fan deck.
 - B. All risers are insulated.
 - C. Thermostats shipped loose for field installation.
 - D. Risers are factory piped to coil with valves as specified.
 - E. Blower, motor, valves, coil and filter are accessible through the return air opening.
 - F. Unit and control box are insulated.
 - G. Riser length = [(floor to floor) + 2 inches (51)]. Maximum riser length is 119 inches (3023). Consult riser submittals for specifications.
 - H. Maximum riser diameter is 2-1/2 inches (64). If larger diameters are required, consult the factory.
 - I. Expansion loops in hot water heating circuits as required.
 - J. Slots provided in the back panel for coil connection to permit expansion and contraction of risers. Coil connections to be at the center of the slots.
 - K. See unit arrangements for supply and return air orientation.
 - L. Dimensions are in inches, dimensions in () are in millimeters.

Drawing is provided for reference only.
 Dimensions may vary with options ordered.
 Consult IEC website for submittal drawings.

Submittal Data, Cont'd.

MSY – Modular Hi-Rise Concealed (Secondary)

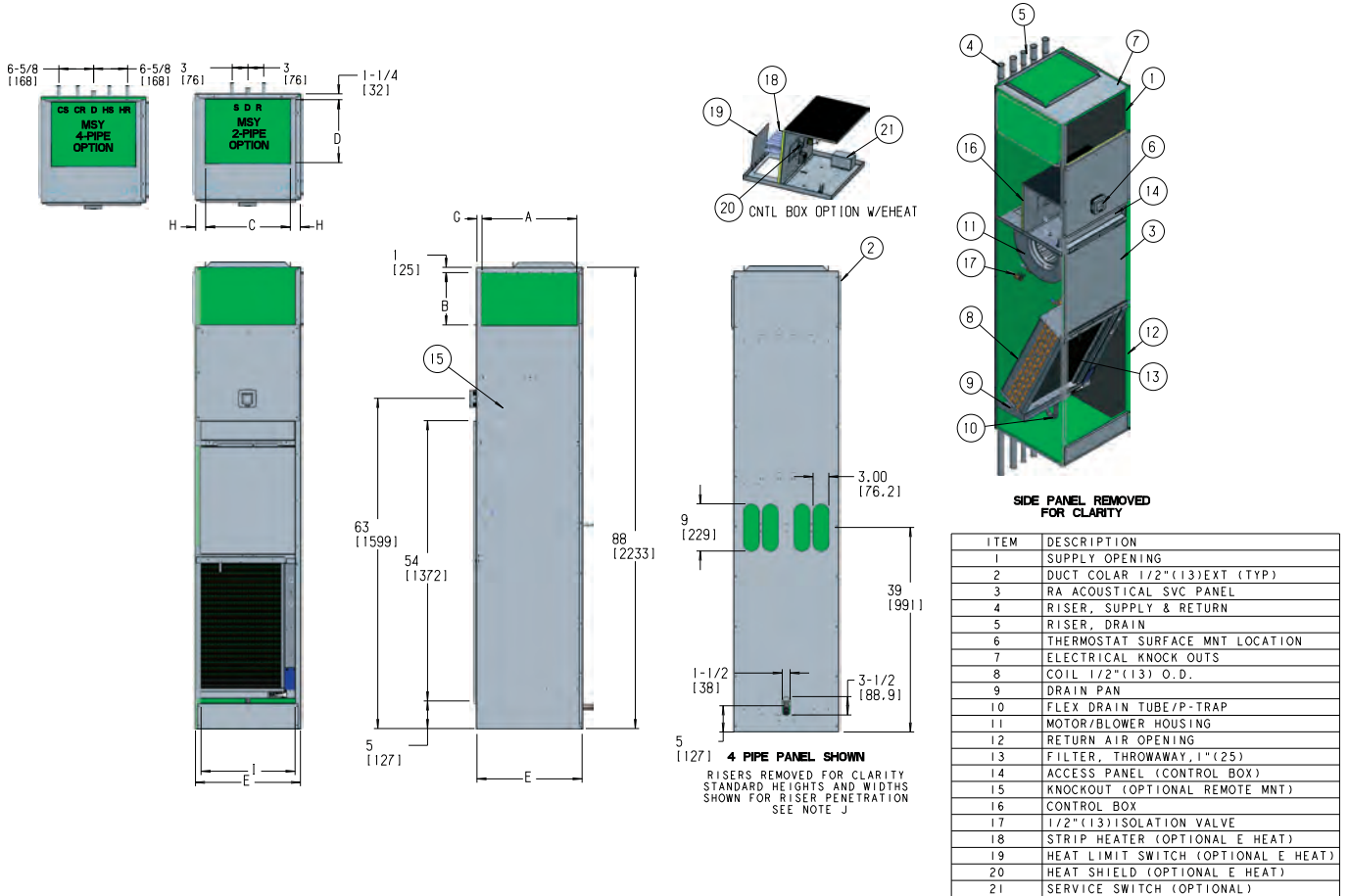

Unit Model	Dimension – Inches (Millimeters)										Unit Weight*
	Single Supply		Double Supply		Top Supply		Dimensions				
	A	B	A	B	C	D	E	G	H	I	
MSY 03	14 (356)	8 (203)	14 (356)	6 (152)	14 (356)	10 (254)	17 (432)	1-1/2 (38)	1-1/2 (38)	14 (356)	162 (73)
MSY 04	14 (356)	12 (305)	14 (356)	6 (152)	14 (356)	10 (254)	17 (432)	1-1/2 (38)	1-1/2 (38)	14 (356)	203 (92)
MSY 06	18 (457)	10 (254)	18 (457)	6 (152)	16 (406)	12 (305)	20 (508)	1 (25)	2 (51)	18 (457)	216 (98)
MSY 08	18 (457)	12 (305)	18 (457)	6 (152)	16 (406)	12 (305)	20 (508)	1 (25)	2 (51)	18 (457)	234 (106)
MSY 10	22 (559)	16 (406)	22 (559)	8 (203)	18 (457)	16 (406)	24 (610)	1 (25)	3 (76)	22 (559)	252 (114)
MSY 12	22 (559)	16 (406)	22 (559)	8 (203)	18 (457)	16 (406)	24 (610)	1 (25)	3 (76)	22 (559)	275 (125)

- NOTES:** * Unit weights are approximate (shown in pounds and kg) and are based on dry coils, minimum rows and exclude packaging, valves or other components.
- A. Units are fabricated of galvanized steel with a 16 gauge galvanized fan deck.
 - B. All risers are insulated.
 - C. Coil with valves as specified.
 - D. Blower, motor, valves, coil and filter are accessible through the return air opening.
 - E. Unit and control box are insulated.
 - F. Expansion loops in hot water heating circuits as required.
 - G. Slots provided in the back panel for coil connection to permit expansion and contraction of risers. Coil connections to be at the center of the slots
 - H. See unit arrangements for supply and return air orientation.
 - I. Dimensions are in inches, dimensions in () are in millimeters.

Drawing is provided for reference only.
Dimensions may vary with options ordered.
Consult IEC website for submittal drawings.

Submittal Data, Cont'd.

Riser Chase Appendix

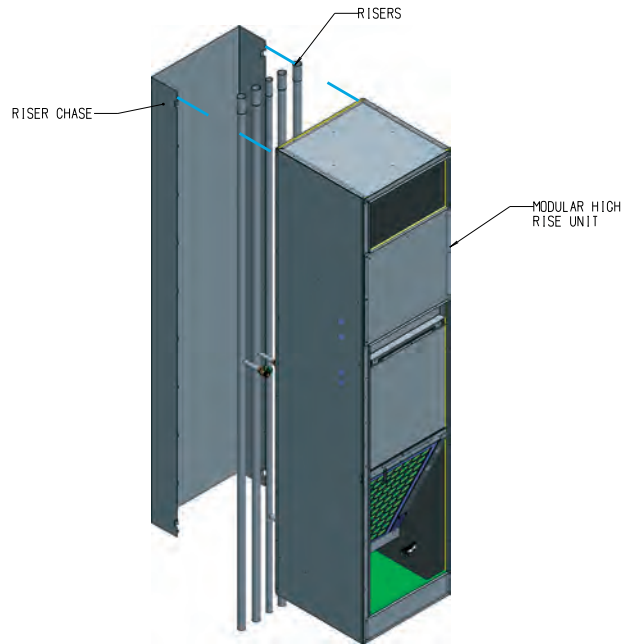
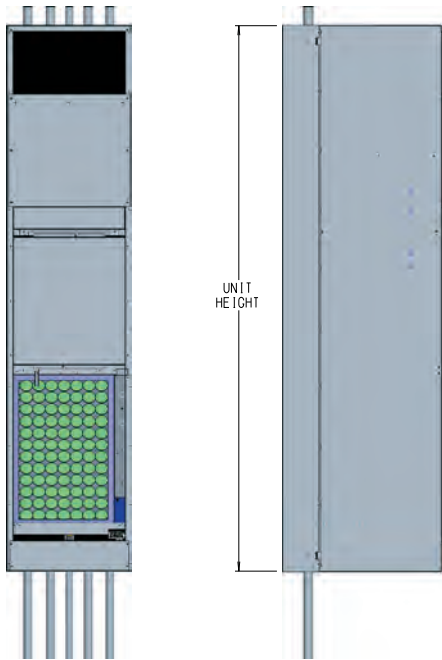
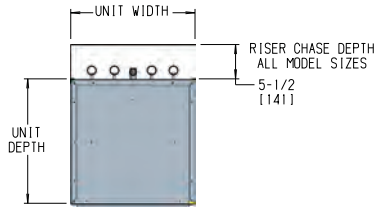

Drawing is provided for reference only.
Dimensions may vary with options ordered.
Consult IEC website for submittal drawings.

Submittal Data, Cont'd.

MXY – Modular Hi-Rise, Cabinet

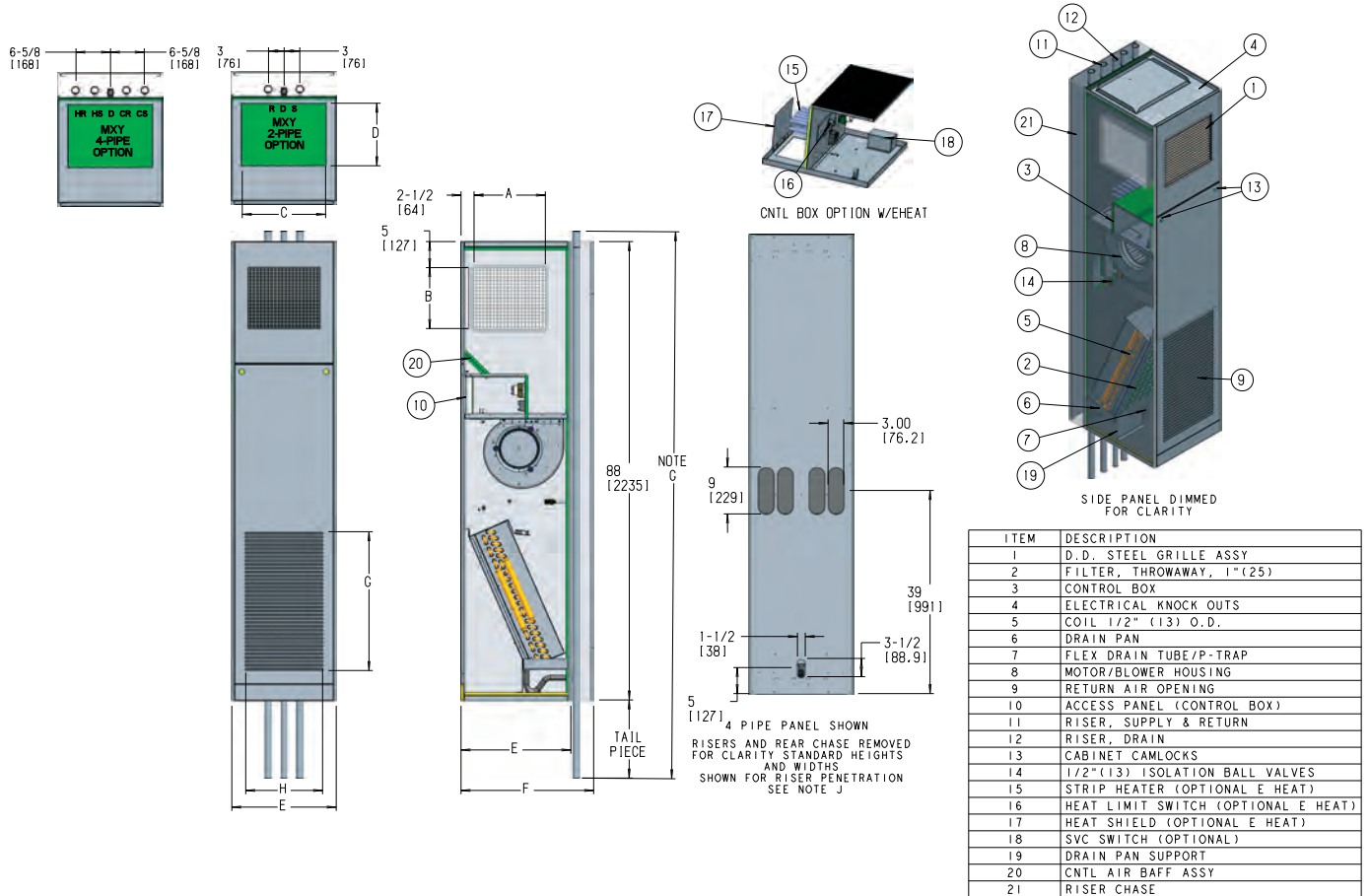

Unit Model	Dimension – Inches (Millimeters)										Unit Weight*
	Side/Front Supply		Double Supply		Top Supply Single		Dimensions				
	A	B	A	B	C	D	E	F	G	H	
MX Y 03	14 (356)	8 (203)	14 (356)	6 (152)	14 (356)	10 (254)	17 (432)	22-1/8(562)	22-1/8(562)	14-3/4 (375)	202 (92)
MX Y 04	14 (356)	12 (305)	14 (356)	8 (203)	14 (356)	10 (254)	17 (432)	22-1/8(562)	22-1/8(562)	14-3/4 (375)	247 (112)
MX Y 06	14 (356)	12 (305)	14 (356)	8 (203)	16 (406)	12 (305)	20 (508)	26-5/8(676)	26-5/8(676)	17-3/4 (451)	262 (119)
MX Y 08	14 (356)	16 (406)	14 (356)	10 (254)	16 (406)	12 (305)	20 (508)	26-5/8(676)	26-5/8(676)	17-3/4 (451)	286 (130)
MX Y 10	18 (457)	16 (406)	14 (356)	12 (305)	18 (457)	16 (406)	24 (610)	31-1/8(791)	31-1/8(791)	17-3/4 (451)	311 (141)
MX Y 12	18 (457)	16 (406)	14 (356)	12 (305)	18 (457)	16 (406)	24 (610)	31-1/8(791)	31-1/8(791)	17-3/4 (451)	336 (152)

NOTES: * Unit weights are approximate (shown in pounds and kg) and are based on dry coils, minimum rows and exclude packaging, valves or other components.

- A. Units are fabricated of galvanized steel with a 16 gauge galvanized fan deck.
- B. All risers are insulated.
- C. Thermostats shipped loose for field installation.
- D. Risers are factory piped to coil with valves as specified.
- E. Blower, motor, valves, coil and filter are accessible through the return air opening.
- F. Unit and control box are insulated.
- G. Riser length = [(floor to floor) + 2 inches (51)]. Maximum riser length is 119 inches (3023). Consult riser submittals for specifications.
- H. Maximum riser diameter is 2-1/2 inches (64). If larger diameters are required, consult the factory.
- I. Expansion loops in hot water heating circuits as required.
- J. Slots provided in the back panel for coil connection to permit expansion and contraction of risers. Coil connections to be at the center of the slots.
- K. See unit arrangements for supply and return air orientation.
- L. Dimensions are in inches, dimensions in () are in millimeters.

Drawing is provided for reference only.
Dimensions may vary with options ordered.
Consult IEC website for submittal drawings.

Coil Data

Table 8. Coil Surface Area

Size	Height (in)	Length (in)
03	25	11
04	25	11
06	27.5	15
08	27.5	15
10	30	19
12	30	19

Table 9. Coil Weight (lbs) (Aluminum fins)

Size	2-Row	3-Row	4-Row	5-Row	6-Row
03/04	17.1	21.5	25.8	30.2	31.6
06/08	23.1	29.6	36.2	42.7	49.3
10/12	27.4	36.2	44.9	53.7	62.4

NOTES: Weights do not include headers or extras.

Table 10. Coil Weight (lbs) (Copper fins)

Size	2-Row	3-Row	4-Row	5-Row	6-Row
03/04	27.4	36.9	46.4	55.9	65.4
06/08	38.8	53.2	67.6	81.9	96.3
10/12	48.7	68.1	87.5	106.9	126.3

NOTES: Weights do not include headers or extras.

Standard Features and Options

Table 11.

Features and Options	Standard	Factory Installed Option	Field Installed Option	Factory Special Quote
Air Flow Arrangement				
See Unit Configuration	X			
Coils				
3-Rows 2-Pipe (MPY, MXY, MMY/MSY, MAY/MBY)	X			
4-Rows 2-Pipe (MPY, MXY, MMY/MSY, MAY/MBY)		X		
3/1, 3/2, or 4/1-Rows CW/HW (MPY, MXY, MMY/MSY, MAY/MBY)		X		
Manual Air Vent	X			
Automatic Air Vent		X		
DX Coiling Coil		X		
Epoxy Coating		X		
Drain Pan				
Stainless Steel Externally Coated with a 2 part closed cell foam	X			
Fin Material				
Aluminum w/Galvanized End Sheets	X			
Aluminum w/Stainless Steel End Sheets & Bottom Coil Baffle		X		
Copper w/Stainless Steel End Sheets & Bottom Coil Baffle		X		X
Nichrome Wire Strip Electric Heater				
		X		
Indoor Air Quality				
1" Throwaway non-woven synthetic	X			
1" Permanent (washable media or aluminum mesh)		X		X
1" MERV 8 Pleated		X		
Bipolar Ionizer		X		
Insulation				
1/2" Standard Fiberglass	X			
1/2" Premium IAQ Fiberglass, sealed edges		X		X
1/2" Foil Face, taped edges		X		
1/4" Closed Cell		X		
1 Hour Fire Rated Riser Chase (MAY/MBY)				
	X			
Motor Type				
ECM Motors	X			
Motor Voltage				
120/1/60 3-Speed	X			
208/230/277/1/60 3-Speed		X		
Supply Grilles				
Integral Double Deflection Aluminum Supply Grille (MXY)	X			
Double Deflection, Aluminum Supply Grille			X	
Double Deflection, Aluminum Supply Grille w/Opposed Blade Dampers			X	
Custom Supply Grille			X	X
Return Air Panel				
Louvered Front Panel (MXY)	X (M)			
Standard Height with or without Frame (All except MXY)	X (F)		X (F, H, Q)	
Extended Height with or without Frame (All except MXY)			X (G, J)	
Extended Height with or without Control Door (All except MXY)			X (K, L)	
Custom Return Air Panel			X	X
Cabinet Modifications				
Standard Height is 88", 79" Optional	X (88")	X (79")		X
Custom Options		X		X

table continued on next page

Modular Hi-Rise Series

FAN COIL TECHNICAL CATALOG

Standard Features and Options, Cont'd.

Table 11., Cont'd.

Features and Options	Standard	Factory Installed Option	Field Installed Option	Factory Special Quote
Paint Options (Return Air Panel, Supply Air Grille)				
Arctic White	X			
Polar White, Flat Black, Ermine Gray, Champagne Beige, Toffee Brown		X		
Special Color				X
Risers				
Riser Factory Installed		X		
Risers Shipped Loose			X	X
Flex Hoses		X	X	X
Riser Length (to 119")	X			X (>119")
Riser Diameter (3/4" to 4")	X			X (>4")
Closed Cell Riser Insulation				
1/2"	X	X		
3/4"		X		
Fiberglass Riser Insulation				
1/2"		X		X
1"		X		X
Riser/Drain Material				
Type M Copper	X	X	X	
Type L Copper		X	X	
Riser Extension (M or L)			X	
Controls				
Service Switch with Lockout Tabs		X		
Single Point Power Connection		X		
Incoming Power Fusing		X		
24V Controls		X		
Condensate Float Switch		X		
Thermostats		X	X	
Surface Mounted w/Tile Ring			X	
Unit Mounted		X		
Wall/Remote Mounted			X	
Special Control (DDC)		X		X
Outside Air Dampers				
Manual Controlled Damper		X		
Motorized Controlled Damper		X		X
Valve Package Options* (* Valve packages are assembled at the factory but field installed.)				
Union Connections at the Coil			X	
24" Braided Hoses			X	
Ball Valves			X	
2-Way/3-Way 25 psi Control Valve			X	
2-Way/3-Way 150 psi, Normally Closed, Control Valve			X	
2-Way/3-Way 150 psi, Normally Open, Control Valve			X	
2-Way/3-Way 35 psi Floating Control Valve			X	
2-Way/3-Way 35 psi Proportional Control Valve			X	
Fixed Flow Control 1.0-8.0 GMP			X	
Y-Strainer/Y-Strainer with Blowdown			X	
P-T Ports			X	
Circuit Setter			X	
Balance Valve (Return Line)			X	
Balance Valve (3-Way Bypass)			X	

Standard Features and Options, Cont'd.

Control Packages

Controls

We offer control packages that fit most customer needs. Additional controls and devices are available to meet even the most demanding operating logic.

Low Voltage Control (24V)

The 85 Control Board offers simplified install and service with its plug-in connections and QR code for quick wiring diagram reference. It also offers LED diagnostics and built-in design flexibility for added features such as staged cooling or BAS signal input. The 85 Control board is available with most control schemes.

85 Control Board Standard Features

- Simplified plug connections
- PSC or ECM control
- LED diagnostics (See IOM-051 for detailed LED function and outcome)
- QR code to wire diagram for ease of troubleshooting
- Compatibility with most actuator types (excludes proportional or modulating actuators)
- Removable thermostat connector

85 Control Board Options

- ECM fan speed adjustment
- Staged Cooling: compatible with IEC Venture Wi-Fi Thermostat (E055 - 1520330)
- BAS signal input to interrupt fan and actuators
- Fusing and service switch with electric heat
- Changeover or aquastat sensor
- Condensate switch LED indication
- Damper control

Condensate Float Switch

This switch shuts down the motor, actuator and electric heat (if applicable) when the water level in the drain pan reaches an unsafe level.

Service Switches

We offer concealed service switches for use by maintenance and service personnel to shut off the power while working on the unit.

Fusing

We offer incoming power fusing for all units as well as blower motor and control sub-fusing (single power source wiring).

Other Control Options

- Unit mounted 3-speed switch (thermostat by others)
- 4-Speed silent switching board with potentiometers
- Low voltage remote shutdown relays (Special Quote)
- Fan and valve cycle applications (Special Quote)
- Thermostats available with large letter print for handicap applications (Special Quote)

Standard Features and Options, Cont'd.

Controls Packages, Cont'd.

85 Control Board

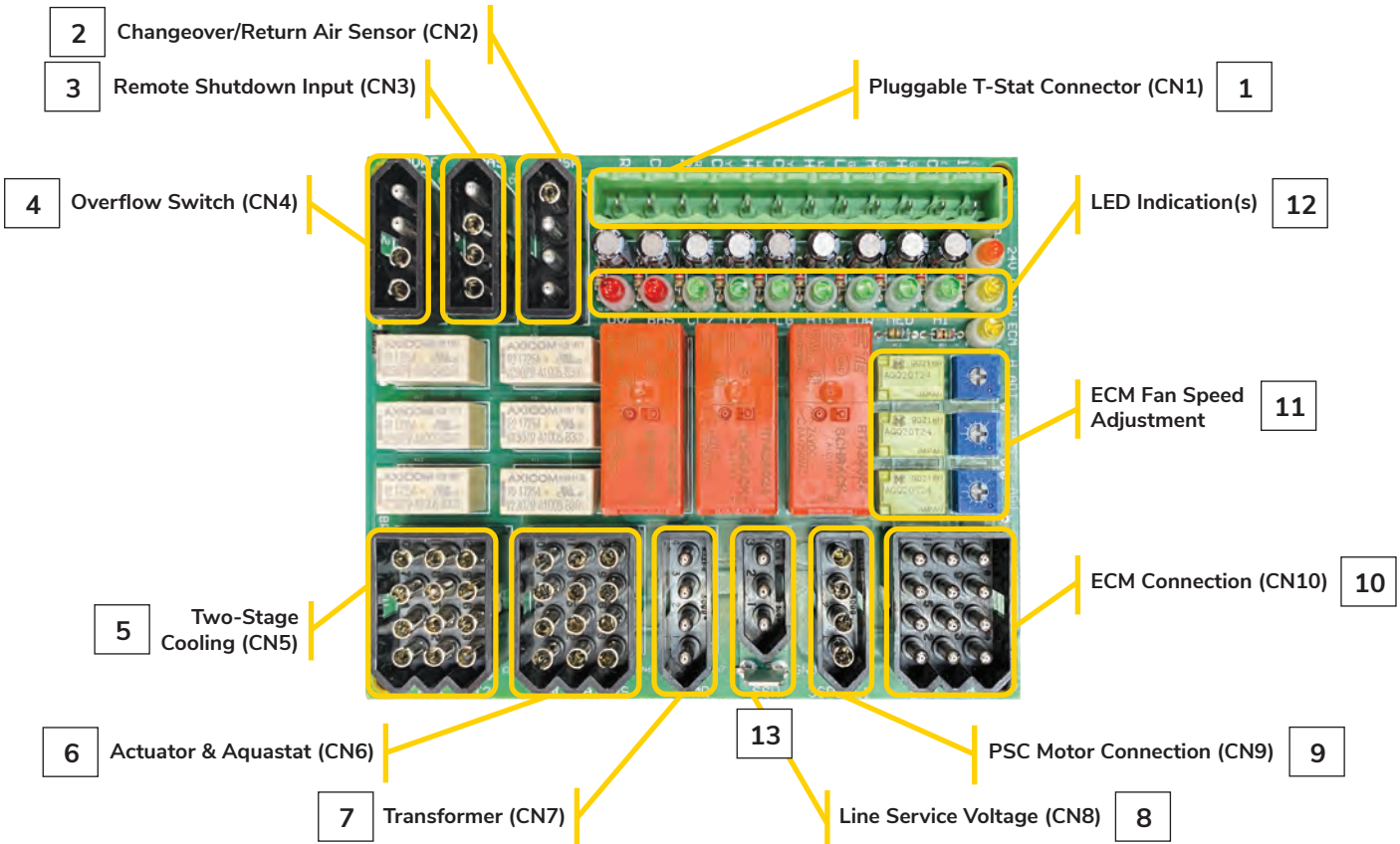

1	CN1 – 24V Customer Input (Thermostat)
2	CN2 – Changeover/Return Air Sensor
3	CN3 – Remote Shutdown Input
4	CN4 – Condensate Overflow Switch
5	CN5 – Two Stage Cooling
6	CN6 – Actuator & Aquastat
7	CN7 – Transformer
8	CN8 – Line Service Voltage
9	CN9 – PSC Motor Connection
10	CN10 – ECM Connection
11	ECM Fan Speed Adjustment
12	LED Diagnostics
13	Ground Connection

Standard Features and Options, Cont'd.

Table 12. Control Package Applications

Unit Type	Control Option	System Type	Changeover Type	W	P	N	F	G
-	Manual Fan	Manual ¹	None	-	-	-	-	-
2-Pipe	Valve Cycle*	Heat Only	None	•	•	•	•	•
		Cool Only	None	•	•	•	•	•
		Heat/Cool	Manual	-	-	-	-	-
			Automatic	•	•	•	•	•
		Heat/Cool with Auxiliary Electric Heat	Manual	-	-	-	-	-
			Automatic	•	•	•	•	•
		Cool with Total Electric Heat	Manual	-	-	-	-	-
			Automatic	•	•	•	•	•
4-Pipe		Heat/Cool	Manual	-	-	-	-	
			Automatic	•	•	•	•	

NOTES: 1. Fan switch only; no thermostat

Table 13. Thermostat Features

All listed controls include fan switching.	Control Type ¹				
	W	P	N	F	G
24V, 115V, 208V, 240V, 277V	24V only	24V only	24V only	24V only	24V only
Wi-Fi Enabled	•	-	-	-	-
Mobile and Web App for Remote Control	•	-	-	-	-
Staged Cooling	•	-	-	-	-
Programmable	•	•	-	•	-
Remote Wall Mounted	•	•	•	•	•
Manual Fan Switch Operation	•	•	•	•	•
Auto Fan Speed Control	•	•	•	•	•
Continuous 3-Speed Fan	•	•	•	•	•
Cycling Fan	•	•	•	•	•
O.A Damper Signal	•	•	•	•	•
Remote Temperature Sensor	Opt	Opt	Opt	Opt	Opt
Digital Display & Buttons	•	•	•	•	•
Local Temperature Set-Back	•	•	•	•	•
Water Temperature Purge Cycle	•	•	•	•	•
Proportional Control Valves	-	-	-	•	•
Floating Control Valves	-	-	-	-	-
Pipe Sensor	•	•	•	•	•

NOTES: 1. Control packages with valve cycle control are continuous fan operation only.
 2. All wall-mount control packages are shipped loose for field installation. (Boxes, tile rings, plaster rings, etc. are not provided).
 3. Aquastats are included in control packages, as required.

*LEGEND: P • Basic 24 V Digital, 7-Day Programmable
 N • Basic 24 V Digital, Non-Programmable
 F • Premium 24 V Digital, 7-Day Programmable/BACnet with Proportional Fan/Valves Option
 G • Premium 24 V Digital BACnet with Proportional Fan/Valves Option
 W • Venture 24 V Wi-Fi Programmable

Standard Features and Options, Cont'd.



Venture 24V,
Wi-Fi Programmable



Basic 24V Digital
7-Day Programmable and
Non-Programmable Series



Premium 24V Digital
7-Day Programmable/BACnet

Standard Features and Options, Cont'd.

Return Air Panels



Stamped Panel Stamped Panel w/Frame Perimeter Panel Tall Stamped Panel (for Unit Mounted Thermostat) Tall Stamped Panel w/Frame (for Unit Mounted Thermostat) Tall Stamped Panel Tall Stamped Panel w/Frame

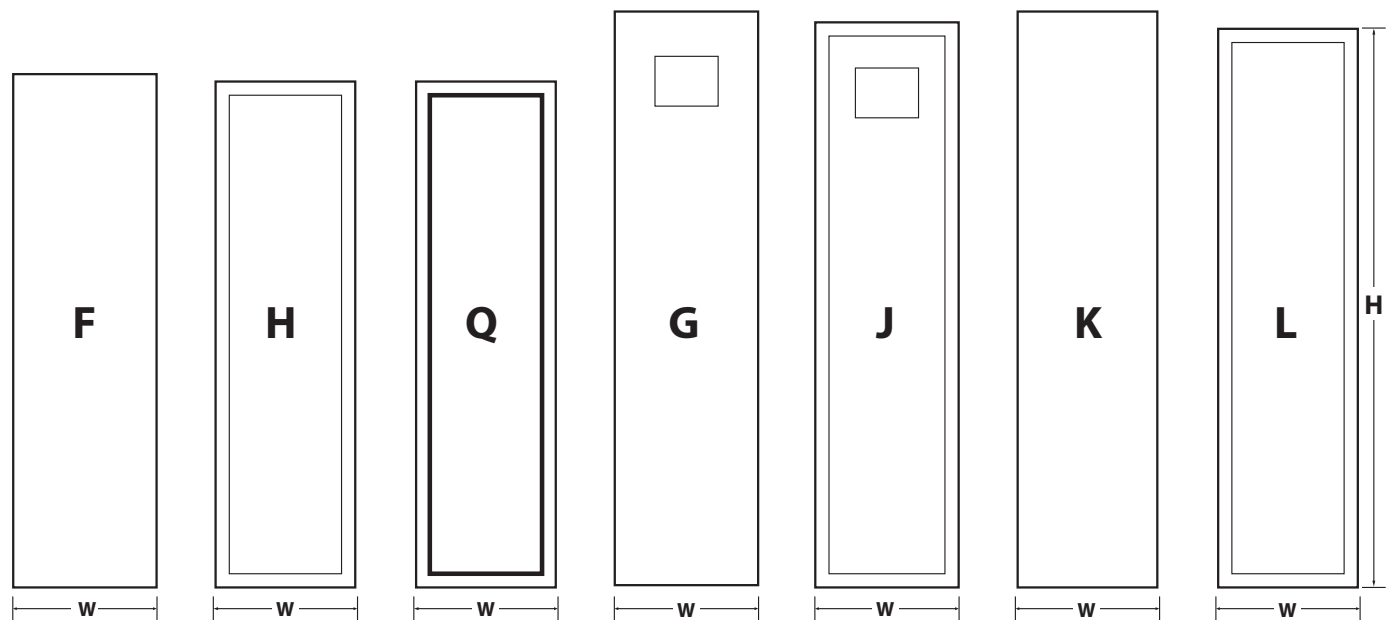

NOTE: See table on next page for height and width information.

Standard Features and Options, Cont'd.

Table 14.

Panel Type	Unit Size and Dimensions					
	03/04		06/08		10/12	
	H	W	H	W	H	W
F	55.5 (1410)	15.5 (394)	55.5 (1410)	19.5 (495)	55.5 (1410)	23.5 (597)
G	61.1 (1552)	15.5 (394)	61.1 (1552)	19.5 (495)	61.1 (1552)	23.5 (597)
H	54.7 (1389)	15.1 (384)	54.7 (1389)	19.1 (485)	54.7 (1389)	23.1 (587)
J	60.4 (1534)	15.1 (384)	60.4 (1534)	19.1 (485)	60.4 (1534)	23.1 (587)
K	61.1 (1552)	15.5 (394)	61.1 (1552)	19.5 (495)	61.1 (1552)	23.5 (597)
L	60.4 (1534)	15.1 (384)	60.4 (1534)	19.1 (485)	60.4 (1534)	23.1 (587)
Q	54.4 (1382)	16.7 (424)	54.4 (1382)	20.7 (526)	54.4 (1382)	24.7 (627)

NOTE: Dimensions shown in inches and millimeters {inches(mm)}.

Return Air/Access Panel Application

Control Mounting Options	Panel
1. Surface mounted controls: This requires a tile ring mounted above the return air panel and quick-connect plug wiring on the thermostat. After the drywall/sheet rock has been applied to the cabinet, the thermostat plug will be attached to a matching plug in the unit and the thermostat will be fastened to the tile ring. (Not available for MXY models)	F, H, R, S
2. Unit mounted: Thermostat is mounted behind the control door or the return air panel.	G, J, K, L
3. Remote wall mounted: Thermostat is mounted on a wall remote from the cabinet and wiring from the unit to thermostat is done in the field.	F, H, K, L, R, S
4. Other Considerations: All above (#1, 2, & 3) are for drywall attached directly to the cabinet. (Not available for MXY models).	F, H, J, L, R, S

General Specifications:

- Heavy gauge galvanized steel with arctic white powder-coat finish
- Rear of panel is insulated with 1/2" dual density fiberglass
- Integral stamped steel return air grille
- 1/4 turn tamper-proof fasteners for panel removal
- Removal of panel provides service access to all internal components
- Framed panel series requires separate field installation of frame

Standard Features and Options, Cont'd.

Supply Air Grilles

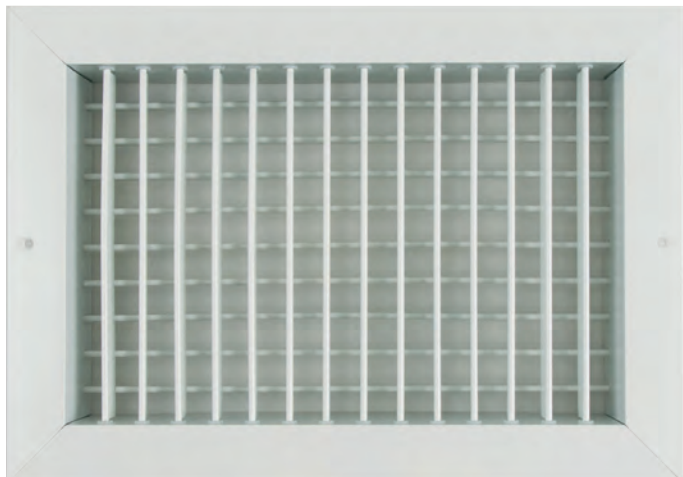

NOTE: Standard style supply air grille shown.

Frame and blades are 6063 extruded aluminum alloy with 200-R1 satin anodized finish. The frame has a typical wall thickness of .050" and is separated from the blades with injection-molded nylon bushings. This method of assembly minimizes corrosion and vibration. The frame mounting holes are dimpled, allowing for a counter-sunk fastener head appearance. (Suitable for sidewall application.)

All blades are airfoil in design, individually adjustable and spaced 3/4" on center. At the outer edge of the frame is a specially engineered channel which retains an extruded flexible vinyl bulb gasket that produces a positive air seal at the mounting surface, minimizing smudging.

An optional opposed blade damper is screwdriver-operated through the face of the unit and has the same extruded aluminum construction and injection-molded nylon bushings.

The unit achieves an effective area of 80% with the blades set at a 0° pattern, thus eliminating high velocity and pressure drop at the grille face. Wider deflection with reduced throw may be achieved at the 22° and 45° blade settings with slightly increased sound levels.

Table 15.

Unit Size	Nominal CFM	Recommended Grille Sizes		
		Single Supply*	Double Supply	Top Supply
03	300	14 (356) x 8 (203)	14 (356) x 6 (152)	14 (356) x 10 (254)
04	400	14 (356) x 12 (305)	14 (356) x 6 (152)	14 (356) x 10 (254)
06	600	18 (457) x 10 (254)	18 (457) x 6 (152)	16 (406) x 12 (305)
08	800	18 (457) x 12 (305)	18 (457) x 6 (152)	16 (406) x 12 (305)
10	1000	22 (559) x 16 (406)	22 (559) x 8 (203)	18 (457) x 16 (406)
12	1200	22 (559) x 16 (406)	22 (559) x 8 (203)	18 (457) x 16 (406)

NOTE: Single-side supply units are available with indicated supply openings on 88 inches tall cabinets only. Consult the factory for cabinets less than 88 inches.

Specifications

Framed Aluminum Return Air Grille and Supply Air Grille

The Framed Aluminum Return Air Grille and Supply Air Grille are available through Special Feature Request only. Contact factory for application.



- Type R:**
Anodized Aluminum
- Type S:**
Arctic White

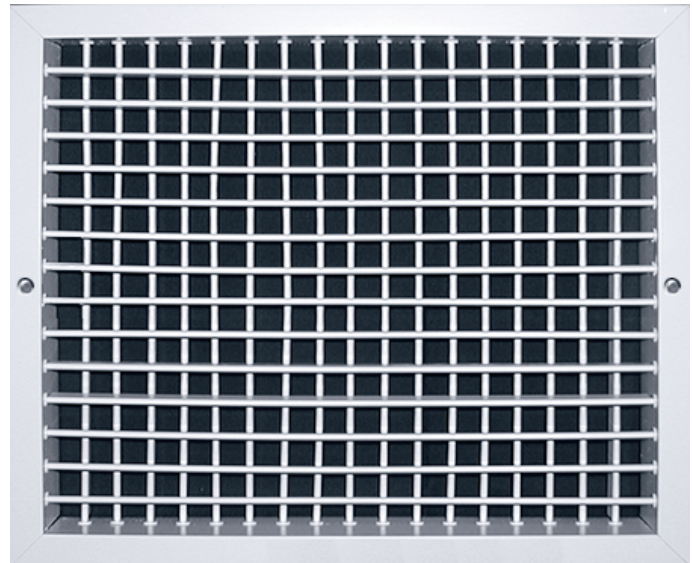

NOTE: Aluminum style supply air grille shown. Reference Table 14 for grille dimensions.

General Specifications:

- Fully louvered core grille is mounted in a full frame.
- Core grille is removable without tools and provides access to all internal components.
- Frame is clear anodized extruded aluminum.
- Grille louvers are also clear anodized extruded aluminum.
- Designed for use with surface mounted or remote wall mounted controls.
- Use with dry wall directly applied to cabinet or with space between dry wall and cabinet.

Table 16.

	Unit Size and Dimensions ¹		
	03/04	06/08	10/12
W	15.2 (386)	19.2 (488)	23.2 (589)
H	55.3 (1405)	55.3 (1405)	55.3 (1405)

NOTE: Dimensions shown in inches and millimeters {inches(mm)}.

Filters

Table 17.

Unit Size	Nominal 1" Filter Size
	MPY, MAY/MBY, MMY/MSY, MXY
03	12-1/2 (316) x 24-1/4 (616)
04	12-1/2 (316) x 24-1/4 (616)
06	16-1/4 (413) x 26-3/4 (679)
08	16-1/4 (413) x 26-3/4 (679)
10	20-1/2 (521) x 29-1/4 (743)
12	20-1/2 (521) x 29-1/4 (743)

NOTE: Sizes shown are nominal ordering sizes.

Table 18. Filter Static Resistance (in w.c.)

Unit Data			Filter Pressure Drop		
Model	Unit Size	Nominal CFM	1" Throwaway	1" Permanent	1" Merv 8
M*Y	03	300	0.034	0.049	0.11
	04	400	0.045	0.074	0.13
	06	600	0.045	0.074	0.13
	08	800	0.058	0.114	0.16
	10	1000	0.056	0.106	0.15
	12	1200	0.065	0.141	0.17

Bipolar Ionizer Specifications

SPECIFICATIONS:

Airflow Capacity: 2,400 CFM
 Pressure Drop: Less than 0.01 In. WG
 Housing Material: ABS
 Weight: 0.2 lbs.
 Maximum Operating Temperature: 200° F (93°C)
 Electrical:

Voltage: 24V AC (602)
 Power Consumption: Less than 1 watt
 Frequency: 50/60 hertz
 Over Current Protection:.. 500mA Glass Cartridge Fuse
 Lead Wires 50"(L)

Ionization Output:

Mode of Operation Needlepoint Type
 Needle Configuration: Brush Type

DIMENSIONS: See Figure 1

APPROVALS:

Intertek/ETL tested in accordance with:

- UL 867: Electrostatic Air Cleaners
- UL 2043: Fire Test for Heat and Visible Smoke

UL Validated:

- 2998: Zero Ozone Emissions

Figure 1. Dimensions not to scale.

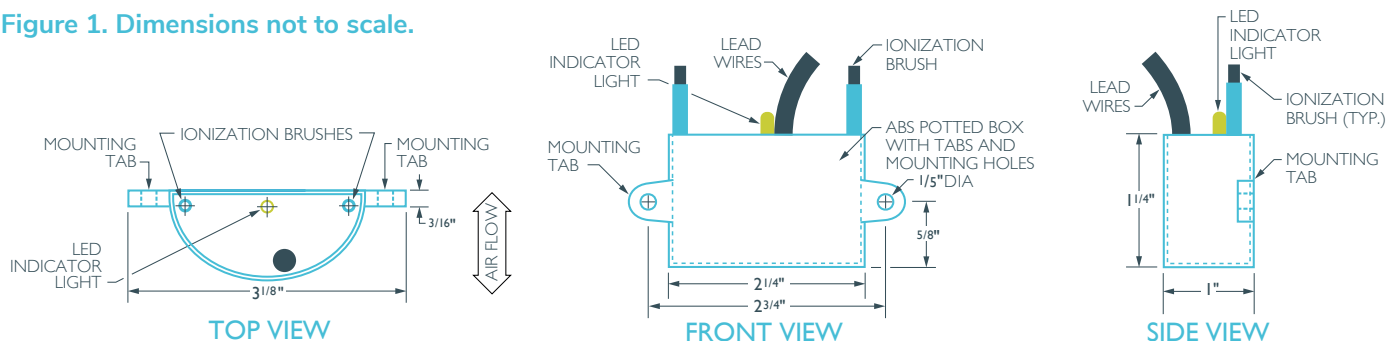

Modular Hi-Rise Series

FAN COIL TECHNICAL CATALOG

This page intentionally left blank.

This page intentionally left blank.

Modular Hi-Rise Series

FAN COIL TECHNICAL CATALOG



Contact your local IEC Sales Representative for further details and pricing applicable to this product. Visit our website (iec-okc.com) to find your local IEC Sales Rep.

IEC Part Number: I100-90002105
CA-050 Revision 20.1 (11/2022)

©2000-2022 International Environmental Corporation (IEC)



5000 W. I-40 Service Rd.
Oklahoma City, OK 73128
P: 405.605.5000
F: 405.605.5001
www.iec-okc.com