

Installation Instructions and Homeowner's Manual

OIL FIRED FURNACE UPFLOW

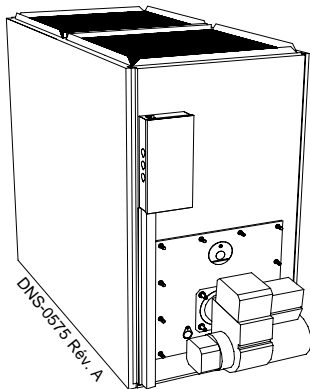
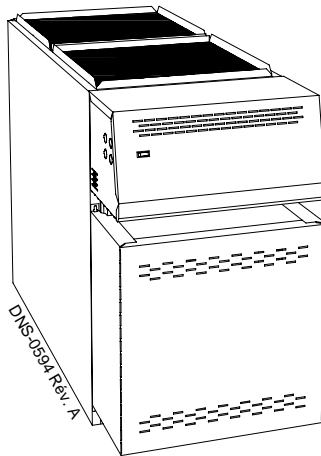
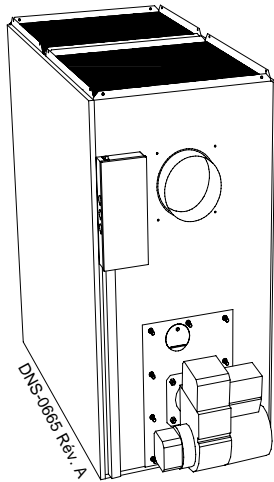

Models :

FLO115DABR-C
LBO125DABR13-D
LBO145DABR34-D
MBO115DABR-D
MBOV115DABR-D
OLF140C12C
OLR182A16C



INSTALLER / SERVICE TECHNICIAN:

USE THE INFORMATION IN THIS MANUAL FOR THE INSTALLATION AND SERVICING OF THE UNIT. KEEP THE DOCUMENT NEAR THE FURNACE FOR FUTURE REFERENCE.

HOMEOWNER:

PLEASE KEEP THIS MANUAL NEAR THE FURNACE FOR FUTURE REFERENCE.

Caution: Do not tamper with the unit or its controls. Call a qualified service technician.

Manufactured by:
UTC Canada Corporation
ICP Division
3400 Industrial Boulevard
Sherbrooke, Quebec - Canada
J1L 1V8

PART 1 INSTALLATION

SAFETY CONSIDERATIONS

INSTALLATION OF OIL FIRED HEATING UNITS SHALL BE IN STRICT ACCORDANCE WITH THE REGULATIONS OF THE AUTHORITIES HAVING JURISDICTION. IN CANADA CSA B139 AND IN THE UNITED STATES NFPA NO.31-1992 INSTALLATION CODES FOR OIL BURNING EQUIPMENT APPLY.

DO NOT OPERATE FURNACE IN A CORROSIVE ATMOSPHERE CONTAINING CHLORINE, FLUORINE OR ANY OTHER DAMAGING CHEMICALS.

DO NOT STORE OR USE GASOLINE, OR OTHER FLAMMABLE VAPOURS AND LIQUIDS IN THE VICINITY OF THIS OR ANY OTHER APPLIANCE.

1.1) SAFETY LABELING AND WARNING SIGNS

DANGER, WARNING AND CAUTION

The words DANGER, WARNING and CAUTION are used to identify the levels of seriousness of certain hazards. It is important that you understand their meaning. You will notice these words in the manual as follows:



DANGER

Immediate hazards that **WILL** result in death or serious damage to body and/or property.



WARNING

Hazards or unsafe practices that **CAN** result in death or damage to body and/or property.

CAUTION

Hazards or unsafe practices which **CAN** result in damage to body and/or property.

1.2) SAFE INSTALLATION REQUIREMENTS



WARNING

Installation or repairs performed by unqualified persons can result in hazards to them and others. Installation **MUST** conform to local codes or, in the absence of same, to codes of the country having jurisdiction.

The information contained in this manual is intended for use by a qualified service technician familiar with safety procedures and equipped with the proper tools and test instruments.

Failure to carefully read and follow all instructions in this manual can result in death and/or personal injury, property damage, furnace malfunction.



WARNING

Fire hazard

The furnace must be installed in a level position, never where it will slope toward the front. If the furnace is installed in the latter position, oil will drain into the furnace vestibule and create a fire hazard.

NOTE: It is the personal responsibility and obligation of the homeowner to contact a qualified technician to ensure that the installation conforms to applicable local and/or national codes and ordinances.

- This furnace is NOT approved for installation in mobile homes, trailers or recreational vehicles;
- Do **NOT** use this furnace as a construction heater or to heat a building under construction;
- There must be a sufficient supply of fresh air for combustion as well as ventilation in the area where the furnace is located;
- Use only the Type of fuel oil approved for this furnace (see **Rating Plate** on unit). Overfiring will result in heat exchanger failure and cause dangerous operating conditions;
- Visually check all oil line joints for signs of wetness, which would indicate a leak;
- Connect furnace to the chimney;
- The points in Part 2 "Operation" are vital to the proper and safe operation of the heating system. Take the time to ensure that all steps were followed;
- Follow the regulations of the ANSI/NFPA No.31 (in the USA) and CSA B-139 (in Canada) or local codes for placing and installing the oil storage tank;

- i. Follow a regular service and maintenance schedule for the most efficient and safe operation of the furnace.
- j. Before servicing, allow furnace to cool. Always shut off electricity and fuel to the furnace when servicing. This will prevent electrical shock or burns;
- k. Seal supply and return air ducts;
- l. The vent system **MUST** be checked to determine that it is the correct type and size;
- m. Install correct filter type and size;
- n. Unit **MUST** be installed so that electrical components are protected from direct contact with water.

1.2.1) Safety Rules

Your unit is built to provide many years of safe and dependable service, providing it is properly installed and maintained. However, abuse and/or improper use can shorten the life of the unit and create hazards for you, the owner.

- a. The U.S. Consumer Product Safety Commission recommends that users of oil or gas-burning appliances install carbon monoxide detectors. Carbon monoxide can cause serious injury and/or death. Therefore, to help alert people of potentially dangerous carbon monoxide levels, you should have carbon monoxide detectors, listed by a nationally recognized agency (e.g. Underwriters Laboratories or International Approval Services) and maintained in the building or dwelling (see **Note** below).
- b. There can be numerous sources of fire or smoke in a building or dwelling. Fire or smoke can cause death, serious bodily injury and/or property damage. Therefore, in order to alert people of potentially dangerous fire or smoke, you should have fire and smoke detectors installed (listed by Underwriters Laboratories) and maintained in the building or dwelling (see **Note** below).

NOTE: The manufacturer of your furnace does not test any detectors and makes no representations regarding any brand or type of detector.

CAUTION

Ensure that the area around the combustion air intake terminal is free of snow, ice and debris.

CAUTION

Do not use any commercially available soot remover. This furnace has a fibre type refractory combustion chamber. Normal servicing of this unit does not require cleaning of the combustion chamber. Use extreme care if for any reason you have to work in the area of the combustion chamber.

1.2.2) Freezing temperatures and your building

WARNING

Freezing temperature warning.

Turn off water supply.

If your heater remains shut off during cold weather the water pipes could freeze and burst, resulting in serious water damage.

Your unit is equipped with safety devices that may keep it from operating if sensors detect abnormal conditions such as clogged exhaust flues.

If the structure is unattended during cold weather you should take the following precautions:

- a. Turn off main water supply into the structure and drain the water lines if possible. Open faucets in appropriate areas;
- b. Have someone check the structure frequently during cold weather to make sure it is warm enough to prevent pipes from freezing. Contact a qualified service agency, if required.

1.2.3) Installation regulations

All local and national code requirements governing the installation of oil burning equipment, wiring and flue connections **MUST** be followed. Some of the codes that may be applicable are:

CSA B139	Installation code for oil burning equipment
NFPA 31	Installation of oil burning equipment
ANSI/NFPA 90B	Warm air heating and air conditioning systems
ANSI/NFPA 70	National electrical code
CSA C22.2 Nr. 3	Canadian electrical code

Only the latest issues of the above codes should be used.

1.3) POSITIONING THE FURNACE

CAUTION

Carefully check your furnace upon delivery for any evidence of damage that may have occurred during shipping and handling. Any claims for damages or lost parts must be made with the Transport Company.

This furnace is approved for reduced clearances to combustible construction. Therefore, it may be installed in a closet or similar enclosure. In any case, the unit must always be installed level.

In a basement, or when installed on the floor (as in a crawlspace), it is recommended that the unit be installed on a concrete pad that is 2.54 cm to 5.08 cm (1" to 2") thick.

The unit must be installed in a location where the ambient and return air temperatures are above 15°C (60°F).

1.3.1) Installation of the filter rack

When you install your furnace, the filter rack opening can be installed on either side (right or left) for air filter maintenance.

FIGURE 1

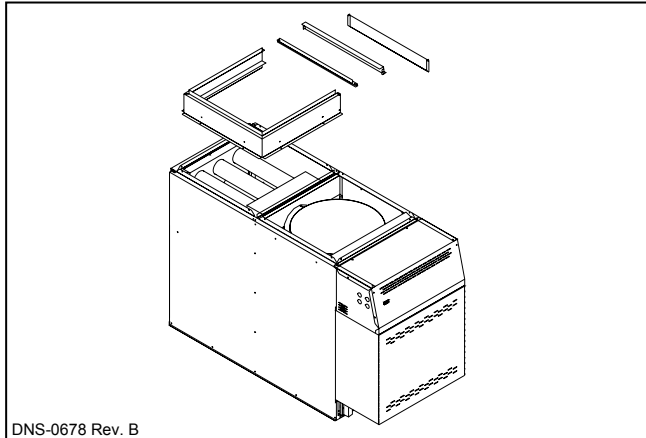

The required minimum clearances for this furnace are specified in Table 1.

The furnace should be positioned as closely as possible to the chimney to keep vent connections short and direct. It should also be as close as possible to the centre of the air distribution system.

CAUTION

Do **NOT** operate furnace in a corrosive atmosphere containing chlorine, fluorine or any other damaging chemicals. Refer to Part 1, section 5.2 (1.5.2).



WARNING

Electrical shock hazard.

This furnace is not watertight and is not designed for outdoor installation. This furnace shall be installed in such a manner as to protect the electrical components from water.

Outdoor installation will lead to a hazardous electrical condition, premature furnace failure, property damage, injury or death.



WARNING

Poisonous carbon monoxide gas hazard.

Never install a hand operated damper in the vent pipe. However, any Underwriters Laboratories listed electrically operated automatic type vent damper may be installed if desired. Be sure to follow the instructions provided with vent damper. Also, read and follow all instructions in this section of the manual.

Failure to properly vent this furnace or other appliances can result in death or personal injury, property damage.

1.4) VENTING



WARNING

Poisonous carbon monoxide gas, fire and explosion hazard.

Read and follow all instructions in this section.

Failure to properly vent this furnace can result in property damage, injury or death.

CAUTION

When the furnace is chimney vented together with other combustion appliances such as a water heater, the allowable venting materials for use with those appliances must be investigated ("L"-Vent, etc.).

These oil furnaces are certified for use with "L" vent, "A" vent, tile-lined and metal-liner-tile-lined chimneys. The appliance may be connected to a chimney of proper size and adequate chimney base temperature, as specified in the Installation Code. The relevant excerpt from the code is found in this section. Use it as a guide when local or national codes do not exist.

Flue pipe sizing

The following table is an excerpt from the installation code that indicates permitted flue sizes and minimum base temperatures for circular flues in chimneys with a thermal resistance of less than R6 (6 ft² •hr •°F / Btu).

Where a new appliance, burner, or chimney is installed, chimney vent sizes and maximum flue-gas temperatures shall comply with Table 2, p. 6. Measurements must be taken at the chimney connector, after 5 minutes of operation with the barometric damper shut.

TABLE 1

Minimum clearances – combustibles materials

LOCATION	APPLICATION	MBO, FLO, LBO125, OLF140	LBO145, OLR182
Sides	Furnace	2.54 cm (1")	2.54 cm (1")
	Supply plenum within 6 ft of furnace	2.54 cm (1")	2.54 cm (1")
Back	Furnace	45.72 cm (18")	45.72 cm (18")
Top	Furnace or plenum	2.54 cm (1")	5.08 cm (2")
	Horizontal warm air duct within 6 ft of furnace	2.54 cm (1")	5.08 cm (2")
Bottom	Furnace (combustible floor)	∅	∅
Flue pipe	Horizontally or below flue pipe	22.86 cm (9")	22.86 cm (9")
	Vertically above flue pipe	22.86 cm (9")	22.86 cm (9")
Front	Furnace	0.60 m (24")	0.60 m (24")

NOTE: Thermal resistance values for typical chimneys are as follows:

- R2 (2 ft² •hr •°F / Btu): Clay-lined masonry, "A" vent
- R3 (3 ft² •hr •°F / Btu): Metal liner in clay-lined masonry
- R6 (6 ft² •hr •°F / Btu): Metal or clay-lined masonry with R4.5 (4.5 ft² •hr •°F / Btu) insulation between liner and masonry (e.g. 2" of expanded mica or 1 3/8" of high density glass fibreboard.)

Applying Table 2

If a furnace with a 0.60 USGPH nozzle is to be connected to a 6.1 m (20') tall clay-lined masonry chimney, the thermal resistance of this chimney type is R2, therefore, inferior to R6. The actual firing rate at 156 psig is 1.25 x 0.60 = 0.75. Therefore this table shall apply as follows:

- The minimum permitted inside diameter shall be 4";
- The maximum permitted inside diameter shall be 5";
- The minimum base temperature shall be about 160°C (320°F).

The vent should not end:

- a) Directly above a sidewalk or mutual driveway;
- b) Less than 2.1 m (7') above a paved driveway;
- c) Less than 1.8 m (6') from a door, window or opening that supplies air to the building;
- d) Above a gas meter or regulator or less than 0.9 m (3') from the centre of the regulator;
- e) Less than 1.8 m (6') from any gas regulator vent exits or less than 0.9 m (3') from an oil tank vent or oil fill inlet;
- f) Less than 0.3 m (1') above ground level or less than 1.8 m (6') from a combustion air inlet;
- g) Less than 1.8 m (6') from a property line;
- h) Under a veranda, porch or patio;
- i) With the combustion gas being directed toward combustible material or openings of a nearby building less than 1.8 m (6') away;
- j) Less than 0.9 m (3') from the interior corner of an "L" shaped structure;
- k) With the opening of the vent located less than 0.3 m (1') from any surface that supports ice, snow or debris.

1.5) AIR FOR COMBUSTION

WARNING

Poisonous carbon monoxide gas hazard.

Comply with ANSI/NFPA (in the U.S.A.) or CSA (in Canada) standards for the installation of Oil Burning Equipment and applicable provisions of local building codes to provide combustion and ventilation air.

Failure to provide adequate combustion and ventilation air can result in death and/or personal injury.

1.5.1) General

Oil furnaces must have an adequate supply of combustion air. It is common practice to assume that older homes have sufficient infiltration to accommodate the combustion air requirement for the furnace. However, home improvements such as new windows, doors, and weather stripping have drastically reduced the volume of air infiltration into the home.

Home air exhausters are common. Bathroom and kitchen fans, power vented clothes dryers, and water heaters all tend to create negative pressure in the home. Should this occur, the chimney becomes less and less effective and can easily downdraft.

Heat Recovery Ventilation (HRV) systems are gaining in popularity. HRVs are not designed to supply combustion air. If not properly balanced, a serious negative pressure condition could develop in the dwelling.

1.5.2) Contaminated Combustion Air

Installation in certain areas or types of structures will increase the exposure to chemicals or halogens which may harm the furnace. These instances will require that only outside air be used for combustion.

The following areas or types of structures may contain or have exposure to the substances listed below. The installation must be carefully evaluated, as it may be necessary to provide outside air for combustion.

- a. Commercial buildings;
- b. Buildings with indoor pools;
- c. Furnaces installed near chemical storage areas.

TABLE 2

Total input rating of all connected appliances			Inside diameter of flue		Minimum base temperature for chimney height			
kW	BTU/h	USGPH	Min.	Max.	11'	20'	28'	36'
21	70,000	0.50	7.62 cm (3")	12.70 cm (5")	149°C (300°F)	204°C (400°F)	279°C (535°F)	385°C (725°F)
27	91,000	0.65	7.62 cm (3")	12.70 cm (5")	135°C (275°F)	171°C (340°F)	221°C (430°F)	279°C (535°F)
31	105,000	0.75	10.16 cm (4")	12.70 cm (5")	127°C (260°F)	160°C (320°F)	193°C (380°F)	246°C (475°F)
36	119,000	0.85	10.16 cm (4")	12.70 cm (5")	121°C (250°F)	149°C (300°F)	179°C (355°F)	221°C (430°F)
41	140,000	1.00	10.16 cm (4")	15.24 cm (6")	107°C (225°F)	149°C (300°F)	185°C (365°F)	221°C (430°F)
51	175,000	1.25	10.16 cm (4")	15.24 cm (6")	116°C (240°F)	135°C (275°F)	160°C (320°F)	185°C (365°F)

Exposure to these substances:

- Permanent wave chemicals for hair;
- Chlorinated waxes and cleaners;
- Chlorine based swimming pool chemicals;
- Water softening chemicals;
- De-icing salts or chemicals;
- Carbon tetrachloride;
- Halogen type refrigerants;
- Cleaning solvents (such as perchloroethylene);
- Printing inks, paint removers, varnishes, etc.;
- Hydrochloric acid;
- Solvent based glue;
- Antistatic fabric softeners for clothes dryers;
- Acid based masonry cleaning materials.

1.5.3) Ducted outdoor combustion air

Outdoor combustion air kit – chimney venting

The following kits have been certified for use with the appliance. The component kits contain an important safety feature, namely a Vacuum Relief Valve or VRV. During normal operation the burner aspirates outdoor air. If the intake terminal ever becomes partially or fully blocked from ice or snow etc., the VRV will open to allow a proportion of air from the dwelling to enter the burner, thus maintaining proper combustion. Once the blockage is removed, the VRV will close and the burner will draw all the air from the outside again:

CAS-2B

Components for the Beckett AFG burner (except air duct): The kit includes the intake terminal, vacuum relief valve (VRV) and special air boot connection with integral air adjustment means for the AFG burner. The CAS-2B can be used with a 10 cm (4") galvanized air duct or a 10 cm (4") flexible aluminium air duct. It is recommended that the metallic air ducting material be insulated from the air intake up to 1.5 m (5') from the burner to avoid condensation from forming on the outside of the intake pipe.

CAD-1

Air duct kit consists of 7.6 m (25') of insulated UL/ULC Listed Class 1 air duct, and two 10 cm (4") steel band clamps. The duct incorporates a corrugated flexible aluminium core, surrounded by fibreglass insulation covered with a vinyl vapour barrier.

CAUTION

The CAS-2B does not turn the furnace installation into a direct vent system. Therefore the building structure must provide for adequate combustion air to be delivered **to the Vacuum Relief Valve**. The burner will need to draw combustion air from the VRV's surroundings if the intake ever becomes blocked. Therefore, non-direct vent installation codes must be followed.

Comprehensive installation instructions are provided with the kits.

1.6) OIL TANKS AND LINES

Check your local codes for the installation of the tank and accessories.

A manual shut-off valve and an oil filter shall be installed in sequence from tank to burner. Be sure that the oil line is clean before connecting to the burner. The oil line should be protected to eliminate any possible damage. Installations where the fuel oil tank is below the burner level must employ a two pipe fuel supply system with an appropriate fuel pump. A rise of more than 2.4 m (8') requires a 2 stage pump and more than 4.9 m (16') an auxiliary pump.

Follow the pump instructions to determine the size of tubing you need in relation to the rise, or to the horizontal distance.

Inspect the entire oil distribution system for leaks at the beginning of each annual heating season.

1.7) BURNER INSTALLATION

FIGURE 2
Ceramic sleeve installation (Riello burner only)

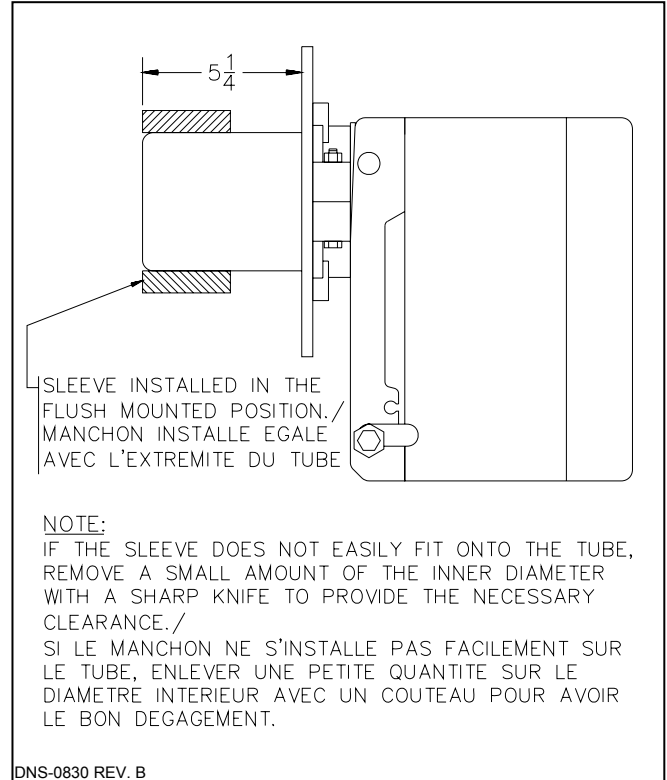

Installing the burner

- Verify tube insertion dimensions in the Technical Specification Tables 3.1 to 3.4, p. 15 to 18.
- The warm air furnace burner mounting plate has a 4-bolt configuration;
- Position the mounting gasket between the mounting flange and the appliance burner mounting plate. Line up the holes in the mounting flange with the studs on the appliance mounting plate and securely bolt in place.

After the burner is mounted

- Remove drawer assembly;
- Install nozzle (see specifications);
- Check electrode settings;
- Make the electrical connections;
- Complete oil line connections.

CAUTION

Do not turn on the burner until you have checked the polarity.

Checking the polarity

The oil burners used on the furnaces have solid state control systems that make them sensitive to the proper connections of the hot and neutral power lines. The controls will be damaged if the two lines are reversed.

1. Set your voltmeter to line voltage;
2. Place one prong on your grounded electric entry box and one prong on the black wire;
3. Read the voltage;
4. If the voltage is zero, check the white wire. If line voltage shows. Reverse the 115-volt leads entering the furnace junction box;
5. If you do not have a voltmeter, use a pilot light.

FIGURE 2.1

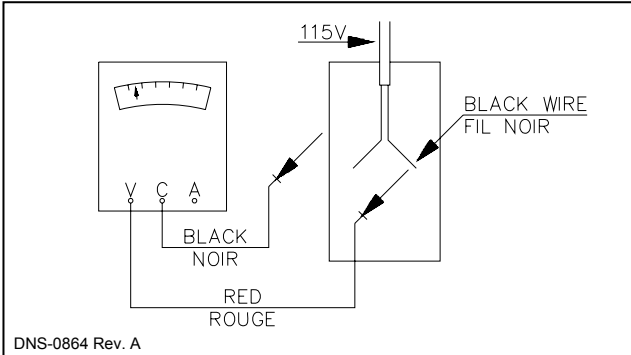

Checking the Nozzle

The burner is equipped with the appropriate nozzle. However, if another size or a replacement nozzle is required, use the manufacturer's recommended spray angle and type as shown in Tables 3.1 to 3.4, p. 15 to 18. Note that all nozzle sizes are based on a pump pressure of 100 psi.

Always select nozzle sizes by working back from the desired flow rate at operating pressure, and not the nozzle marking.

Checking air and turbulator settings

Before starting the burner for the first time, adjust the air and turbulator settings to those listed in the Tables 3.1 to 3.4, p. 15 to 18. Once the burner becomes operational, final adjustment will be necessary.

Checking the fuel supply system

Fuel Specifications

NOTE: Use No.1 or No. 2 Heating Oil (ASTM D396) or in Canada use No.1 or No. 2 Furnace Oil.

Before starting the burner, be sure that the fuel tank is filled with clean oil.

IMPORTANT

When using nozzle sizes of less than 0.75 USGPH, the Installation Code for oil burning equipment requires the installation of a 10 micron (or finer) filter in the fuel oil line. ICP requires that this practice be followed in order to keep the lifetime heat exchanger warranty intact.

WARNING

Fire and explosion hazard.

Use only approved heating type oil in this furnace. DO NOT USE waste oil, used motor oil, gasoline or kerosene.

Use of these will result in property damage injury or death.

NOTE: You may notice a slight odour the first time your furnace is operated. This will soon disappear. It is only the oil used on certain parts during manufacturing.

1.8) BLOCKED VENT SHUT-OFF (BVSO) For chimney venting

WARNING

It is imperative that this device be installed by a qualified agency.

This device is designed to detect the insufficient evacuation of combustion gases in the event of a vent blockage. In such a case the thermal switch will shut down the oil burner. The device will then need to be restarted MANUALLY.

Refer to the wiring diagrams and the detailed instructions supplied with the BVSO for the installation and wiring procedures. The length of wires supplied with the unit is such that the safety device must be installed between the flue outlet of the appliance and the draft regulator, as indicated in the instructions.

It is further imperative that the BVSO be maintained annually. For more details refer to the instructions supplied with the device itself, as well as Section 3 of this Manual.

CAUTION

A positive pressure venting system (Sealed Combustion System or Direct Vent) **MUST NOT** use the BVSO. Follow the instructions supplied with the venting system.

1.9) INSTALLING ACCESSORIES

WARNING

Electrical shock hazard.

Turn OFF electric power at fuse box or service panel before making any electrical connections and ensure a proper ground connection is made before connecting line voltage.

Failure to do so could result in bodily injury or death, property damage.

1.9.1) Air conditioning

An air conditioning coil may be installed on the supply air side only. Also, notwithstanding the evaporator coil manufacturer's instructions, a minimum clearance of 15 cm (6") must be allowed between the bottom of the coil drain pan, and the top of the heat exchanger. Wire the thermostat and condensing unit contactor as indicated in the wiring diagram in Figure 5, p. 21.

1.9.2) Ductwork and Filter

Installation

Design and install the air distribution system to comply with Air Conditioning Contractors of America manuals or other approved methods that conform to local codes and good trade practices.

When ducting supplies air to a space other than where the furnace is located, the return-air ducts must be sealed and also be directed to the space other than where the furnace is located.

Install the air conditioning cooling coil (evaporator) downstream from the supply air plenum of the furnace. If a separate evaporator and blower unit is used, install appropriate sealing dampers for air flow control. Cold air from the evaporator coil going through the furnace could cause condensation and shorten furnace life.

CAUTION

Dampers (purchased locally) **MUST** be automatic.



WARNING

Poisonous carbon monoxide gas hazard.

Do NOT draw return air from inside a closet or utility room. Return air duct MUST be sealed to furnace casing.

Failure to properly seal ducts can result in death, personal injury and/or property damage.



WARNING

Poisonous carbon monoxide gas hazard.

Install evaporator coil on the supply side of the furnace ducting.

Evaporator coil installed in return side ducting can cause condensation to form inside heat exchanger resulting in heat exchanger failure. This could result in death, personal injury and/or property damage.

PART 2 OPERATION

2.1) SEQUENCE OF OPERATION

2.1.1) Sequence of operation Beckett AFG, Riello 40-F and Aero F-FAC

1. Normally open contact (T-T) on primary relay closed when thermostat calls for heat;
2. AFG and F-FAC burner: The motor starts and spark is established. The pump pressure builds and the oil supply mechanism opens, admitting fuel to the nozzle;
3. R40-F Burner: The burner motor starts. The burner motor fan pre-purges the combustion chamber and vent for 10 seconds, establishing the combustion air pattern. During this time the solenoid valve holding coil pressure is approximately 100 psig. The solenoid valve opens, allowing oil to flow through the nozzle. At the same time, the burner motor ignition coil produces a spark;
4. Spark ignites oil droplets;
5. Cad cell senses flame and burner continues to fire. Ignition transformer ceases sparking (Riello R40-F);
6. After Fan-Limit control heats up to the factory set point, the circulating air blower and electronic air cleaner start;
7. The circulating air blower and burner motor remain on until the thermostat is satisfied. The ignition transformer continues to spark (AFG). The solenoid valve remains open (R40-F);

Thermostat is satisfied:

8. Primary relay contacts open, solenoid valve closes (R40-F), burner fan motor shuts down. The ignition transformer ceases sparking (AFG);
9. The Fan-Limit control bi-metal cools down to the factory set point of 32°C (90°F), the circulating air blower and the electronic air cleaner turn off.

2.2) CHECKS AND ADJUSTMENTS

2.2.1) General

After initial installation and subsequent yearly maintenance calls, the furnace must be thoroughly tested.

IMPORTANT

The burner must be functioning for at least 10 minutes before any test readings are taken. Adjustments are to be made according to the Technical Specifications in this manual.

Open the oil bleed port screw and start the burner. Allow the oil to drain into a container for at least 10 seconds. Once the oil flows absolutely free of white streaks or air bubbles to indicate that no air is being drawn into the suction side of the oil piping and pump, slowly close and tighten the bleed screw. The burner should now fire. Adjust the oil pressure as indicated in the Technical Specification Tables 3.1 to 3.4, p. 15 to 18.

2.2.2) Restart after burner failure

1. Set thermostat lower than the room temperature;
2. Press the reset button on the burner primary control (relay);
3. Set thermostat higher than the room temperature;
4. If the burner motor does not start or ignition fails, turn off the disconnect switch and CALL A QUALIFIED SERVICE TECHNICIAN.

CAUTION

Do not attempt to start the burner when excess oil has accumulated, when the furnace is full of vapour, or when the combustion chamber is very hot.

2.2.3) BVSO Performance Test

The purpose of the following test is to check that the electrical outlet on the furnace, designated to the BVSO, is functional.

1. Start up the burner;
2. Remove the three-pole plug from the BVSO outlet on the furnace;
3. The burner must shut-off immediately, while the blower continues to run to the end of the cool-down cycle.

If the test is not in line with the above, CALL A QUALIFIED SERVICE TECHNICIAN.

2.2.4) Combustion chamber curing

Some moisture and binders remain in the ceramic combustion chamber after manufacture. It is important to clear the chamber of this residue before testing. If you smoke test before curing, the instrument may become damaged. To cure the chamber, run the unit for 3 consecutive cycles, with 3 minutes of elapsed time in between each cycle. Each burn cycle should last 3 minutes. The exhaust will have a pungent odour and produce a white cloud of steam.

2.2.5) Smoke / CO₂ test

1. Pierce a test hole in the smoke pipe near the furnace breach. Insert the smoke test instrument probe into the open hole;
2. Starting with a zero smoke reading, gradually reduce the burner air setting until just a trace of smoke results (#1 on Bacharach Scale);
3. Take a CO₂ sample at the same test location where the smoke sample was taken. Note the CO₂ reading associated with the #1 smoke condition;
4. Adjust the burner air setting to obtain a CO₂ reading 1% lower than the reading associated with the #1 smoke;
5. This method of adjusting the CO₂ will allow adequate excess air to ensure that the burner will burn clean for the entire heating season.

2.2.6) Supply air temperature rise test

1. Operate the burner for at least 10 minutes;
2. Measure the air temperature in the return air plenum;
3. Measure the air temperature in the largest trunk coming off the supply air plenum, just outside the range of radiant heat coming off the heat exchanger; 0.3 m (12") from the plenum on the main take-off usually sufficient;
4. The temperature rise is calculated by subtracting the return air temperature from the supply air temperature;
5. If the temperature rise exceeds the temperature specified in Tables 3.1 to 3.4, p. 15 to 18, change to the next higher blower speed tap until the temperature rise falls to this temperature or below. If the excessive temperature rise cannot be reduced by increasing fan speed, investigate for ductwork restriction(s), dirty or improper air filter, overfiring caused by excessive pump pressure, or improper nozzle sizing.

2.2.7) Vent temperature test

1. Place a thermometer in the test hole located in the breech pipe.
2. The vent temperature should be between 204°C to 302°C (400°F to 575°F). If not, check for improper air temperature rise, pump pressure, nozzle size, or for a badly sooted heat exchanger.

2.2.8) Fan Limit adjustment and blower regulator

Modification of the "FAN ON" and "HI" Limit settings on the Fan Limit and blower regulator can cause a malfunction of the furnace and carry to premature wear of the heat exchanger.

CAUTION

Modification of the factory set limits will void the warranty.

FIGURE 3

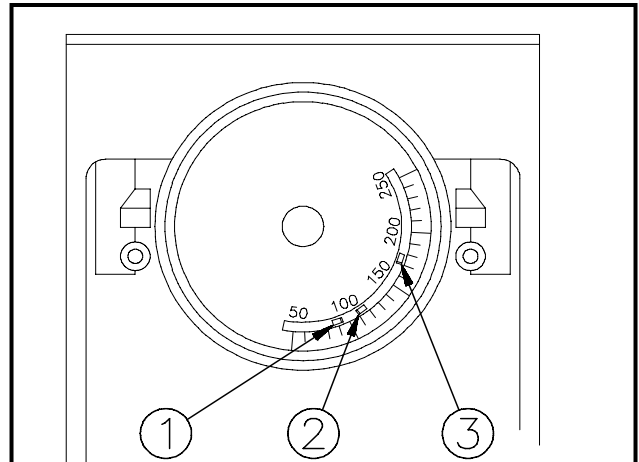

DNS-0355 Rev.B

MBO, MBOV

1	"FAN OFF" Limit	90°F
2	"FAN ON" Limit	110°F
3	"HI" Limit	200°F

LBO & OLR

1	"FAN OFF" Limit	90°F
2	"FAN ON" Limit	130°F
3	"HI" Limit	190°F

FLO & OLF

1	"FAN OFF" Limit	90°F
2	"FAN ON" Limit	110°F
3	"HI" Limit	150°F

PART 3 MAINTENANCE

3.1) GENERAL

Preventive Maintenance

“Preventive maintenance” is the best way to avoid unnecessary expense and inconvenience. Have your heating system and burner inspected at regular intervals by a qualified service technician.

After each annual inspection a complete combustion test must be performed, in order to maintain optimum performance and reliability.



WARNING

Electrical shock hazard.

Turn OFF power to furnace before any disassembly or servicing.

Failure to do so can result in property damage injury and/or death.

Do not tamper with the unit or controls. Call a qualified service technician.

Before calling for service, check the following :

- Check oil tank gauge and check if the oil tank valve in oil is open;
- Check fuse or circuit breaker;
- Check if shut-off switch is “ON”;
- Reset thermostat above room temperature;
- If ignition does not occur turn off the disconnect switch and call a qualified service technician.

When ordering replacement parts, specify the complete furnace model number and serial number.

3.1.1) Heat exchanger cleaning

Ordinarily, it is not necessary to clean the heat exchanger or flue pipe every year, but it is advisable to have your oil burner serviceman check the unit before each heating season to determine whether cleaning or replacement of parts is necessary.

If cleaning is necessary, the following steps should be performed:

- Turn “OFF” all utilities upstream of the furnace;
- Disconnect the flue pipe;
- Remove the flue collar panel located at the rear part of the warm air furnace;
- Remove the radiator baffles;
- Disconnect the oil line and remove the oil burner from the furnace;
- Clean the secondary tubes, and the primary cylinder with a stiff brush and vacuum cleaner;
- The heat exchanger and combustion chamber should be inspected to determine if replacement is required before re-assembling the unit;
- After cleaning, replace the radiator baffles, flue collar plate and oil burner;
- Readjust burner for proper operation.

Soot will have collected in the first sections of the heat exchangers only if the burner was started after the combustion chamber was flooded with fuel oil, or if the burner has been operating in a severely contaminated condition.

3.1.2) Refractory firepot

Remove the burner and check the firepot.

IMPORTANT

Use extreme care if cleaning of the pot is required. After firing, the pot becomes very fragile. Do not use any commercially available soot remover. This furnace has a fibre type refractory combustion chamber. Normal servicing of this unit does not require cleaning of the combustion chamber.

IMPORTANT

Do not vacuum the ceramic chambers—they are easily damaged.

If the pot is damaged, it must be replaced. A damaged pot could lead to premature heat exchanger failure. Cracking of the firepot is normal, however, replace the pot only if the cracks have propagated more than $\frac{2}{3}$ the way through the wall thickness. The average wall thickness of the firepot is $\frac{3}{4}$ ".

Flooding of the firepot

Flooding can occur when the oil primary control has been reset a number of times in a no-heat situation. Each time oil is fired into the pot and does not ignite, it is absorbed into the pot. Even if the burner is removed and the pot is felt for wetness, it is difficult to assess the degree of oil absorption by the pot.

There is only one way to properly service a flooded firepot, and that is to change it.

CAUTION

If you observe the red warning light on the burner, push once **ONLY** to try and restart. If the burner will not start, phone an authorized service technician. Do not press the button again.

3.1.3) **BLOCKED VENT SHUT-OFF (BVSO) CLEANING**

For continued safe operation, the Blocked Vent Shut-Off System (BVSO) is required to be inspected and maintained annually by a qualified agency.

1. Disconnect the power to the appliance;
2. Remove the two screws holding on the BVSO assembly cover;
3. Remove the cover;
4. Remove the two screws holding the control box to the heat transfer tube assembly. Sliding the control box in the appropriate direction will unlock it from the heat transfer tube assembly;
5. Carefully remove any build-up from the thermal switch surface;

CAUTION

Do not dent or scratch the surface of the thermal switch. If the thermal switch is damaged, replacement is required.

6. Clear and remove any build-up or obstruction inside the heat transfer tube;
7. Re-mount, lock and fasten the control box with the 2 screws removed in step 4;
8. Re-attach the assembly cover with the screws removed in step 2;
9. Re-establish power to the appliance.

3.1.4) **Burner drawer assembly**

Remove the drawer assembly. Clean all foreign matter from the retention head and electrodes. If a Beckett AFG burner was installed, the burner will have to be removed to check the retention head.

3.1.5) **Nozzle**

Replace the nozzle with the one specified in Tables 3.1 to 3.4, p. 15 to 18.

3.1.6) **Oil filter**

Tank filter

The tank filter should be replaced as required.

Secondary filter

The 10 micron (or less) filter cartridges should be replaced annually.

3.1.7) **Air filters**

Air filters are the disposable type. They should be replaced at least once a year. Dusty conditions, presence of animal hair etc. may require much more frequent filter changes. Dirty filters will impact furnace efficiency and increase oil consumption.

3.1.8) **Motor lubrication**

Do NOT lubricate the oil burner motor or the direct drive blower motor as they are permanently lubricated.

3.1.9) **CAS-2B combustion air kit (chimney venting)**

If used, check the CAS-2B combustion air kit for proper operation. Check to see that the inlet screen is not plugged. Block the air inlet completely and ensure that a zero smoke reading results. If a zero smoke reading is not obtained, set up the burner as indicated in Tables 3.1 to 3.4, p. 15 to 18.

Gradually block off the intake. The CO₂ should increase to a maximum of 0.5 percentage points at the fully blocked condition. If not, check that the VRV gate is pivoting freely and that the pivot rod is in a horizontal position. Also, check that the counterweight has been properly adjusted in accordance with CAS-2B installation instructions.

**PART 4
INFORMATION**

Model: _____ Serial number: _____

Furnace installation date: _____

Service telephone # - Day: _____ Night: _____

Dealer name and address: _____

START-UP TEST RESULTS

Nozzle: _____ Pressure: _____ Lb/psi

Burner adjustments: Primary air _____

 Fine air _____

 Draw Assembly _____

CO₂: _____ % Smoke scale: _____ (Bacharach)

Gross stack temperature: _____ °F

Ambient temperature: _____ °F

Chimney draft: _____ " W.C.

Overfire draft: _____ " W.C.

Test performed by: _____

TABLE 3.1
Technical specifications, MBO115DABR-D & MBOV115DABR-D

RATING AND PERFORMANCE				
Firing rate USGPH	0.65	0.75	0.85	0.90
Input (BTU/h)	91,000	105,000	119,000	126,000
Heating capacity (BTU/h)	74,000	85,000	97,000	103,000
Maximum temperature rise	13°C - 29°C (55 - 85°F)			
BECKETT BURNER (3450 RPM)	AFG-F3 (TUBE INSERTION 5 3/16")			
Low firing rate baffle	YES			
Static disc, model	2 3/4 #3383			
Nozzle - 100 PSIG pump pressure (Delavan)	0.65 - 70W	0.75 - 70W	0.85 - 70W	
Combustion air adjustment (band / shutter)	0 / 4	0 / 6	0 / 7	
RIELLO BURNER MODEL 40	F3 (TUBE INSERTION 5 1/4")			
Nozzle (Delavan)	0.50 - 60W	0.60 - 60W		0.75 - 60W
Pump pressure (PSIG)	165	155		145
Combustion air adjustment (turbulator / damper)	0 / 2.25	1 / 2.75		2 / 3.75
AERO BURNER (1725 RPM)	FAFC-2 (TUBE INSERTION 5 3/8")			
Nozzle - 100 PSIG pump pressure (Delavan)	0.65 - 70W	0.75 - 70W	0.85 - 70W	
ELECTRICAL SYSTEM				
Volts - Hertz - Phase	115 - 60 - 1			
Operating voltage range	104 - 132			
Rated voltage (Amps)	11.4			
Minimum ampacity for wiring sizing	12.8			
Max. fuse size (Amps)	15			
BLOWER DATA				
Blower speed at 0.4" W.C. static pressure	MED-LO	MED-HI	HIGH	HIGH
Blower speed at 0.2" W.C. static pressure	MED-LO	MED-HI	HIGH	HIGH
Motor / number of speeds	1/3 HP / 4 speeds			
Blower wheel size	10" x 10"			
Filter quantity and size	(1) 20" x 20"			

TABLE 4.1
Air delivery - CFM with air filter

SPEED	MBO115DABR-D & MBOV115DABR-D	
	EXTERNAL STATIC PRESSURE WITH AIR FILTER	
	0.2"	0.4"
MED-LO	1,300	1,150
MED-HI	1,350	1,225
HI	1,400	1,250

TABLE 3.2

Technical specifications, LBO125DABR13-D (BECKETT, RIELLO AND AERO BURNERS)

RATING AND PERFORMANCE				
Firing rate USGPH	0.75	0.85	1.00	1.10
Input (BTU/h)	105,000	119,000	140,000	154,000
Heating capacity (BTU/h)	84,525	95,795	112,700	123,970
Maximum temperature rise	13°C - 29°C (55 - 85°F)			
BECKETT BURNER (3450 RPM)	AFG-F3 (TUBE INSERTION 5 3/16")			
Low firing rate baffle	YES			
Static disc, model	2 3/4 #3383			
Nozzle - 100 PSIG pump pressure (Delavan)	0.75 - 70W	0.85 - 70W	1.00 - 70W	1.10 - 70W
Combustion air adjustment (band / shutter)	1 / 1	1 / 4	2 / 2	3 / 3
RIELLO BURNER; MODEL 40	F3 (TUBE INSERTION 5 1/4")		F5 (TUBE INSERTION 5 1/4")	
Nozzle (Delavan)	060 - 60W	075 - 60W	0.85 - 60W	0.85 - 60W
Pump pressure (PSIG)	155	130	140	170
Combustion air adjustment (turbulator / damper)	2 / 3.25	2.5 / 4	2 / 2.5	3 / 2.5
AERO BURNER (1725 RPM)	FAFC-2 (TUBE INSERTION 5 3/8")			
Nozzle - 100 PSIG pump pressure (Delavan)	0.75 - 70W	0.85 - 70W	1.00 - 70W	1.10 - 70W
ELECTRICAL SYSTEM				
Volts - Hertz - Phase	115 - 60 - 1			
Operating voltage range	104 - 132			
Rated voltage (Amps)	11.4			
Minimum ampacity for wiring sizing	12.8			
Max. fuse size (Amps)	15			
BLOWER DATA				
Blower speed at 0.4" W.C. static pressure	MED-LO	MED-HI	HIGH	N / A
Blower speed at 0.2" W.C. static pressure	MED-LO	MED-HI	HIGH	HIGH
Motor / number of speeds	1/3 HP / 4 speeds			
Blower wheel size (in.)	10 X 10			
Filter quantity and size	(2) 15 X 20			

TABLE 4.2
Air delivery - CFM with air filter

SPEED	LBO125DABR13-D	
	EXTERNAL STATIC PRESSURE WITH AIR FILTER	
	0.2"	0.4"
MED-LO	1,175	1,000
MED-HI	1,250	1,200
HI	1,375	1,300

TABLE 3.3

Technical specifications, LBO145DABR34-D and OLR182A16C (BECKETT, RIELLO AND AERO BURNERS)

RATING AND PERFORMANCE					
Firing rate USGPH	1.00	1.10	1.20	1.25	1.30
Input (BTU/h)	140,000	154,000	168,000	175,000	182,000
Heating capacity (BTU/h)	112,700	123,970	135,240	140,875	146,510
Maximum temperature rise	13°C - 29°C (55 - 85°F)				
BECKETT BURNER (3450 RPM)	AFG-F3 (Tube insertion 5-3/16")				
Low firing rate baffle	YES				
Static disc, model	2 3/4 #3383				
Nozzle - 100 PSIG pump pressure (Delavan)	1.00 - 70W	1.10 - 70W		1.25 - 70W	
Combustion air adjustment (band / shutter)	2 / 3	2 / 6		6 / 6	
RIELLO BURNER; MODEL 40	F5 (Tube insertion 5-1/4")				
Nozzle (Delavan)	0.85 - 60W	0.85 - 60W	1.00 - 60W		1.10 - 60W
Pump pressure (PSIG)	140	170	145		140
Combustion air adjustment (turbulator / damper)	2.5 / 2.5	3 / 2.75	3 / 3		3.5 / 3.25
AERO BURNER (1725 RPM)	FAFC-3 (Tube insertion 5-3/8")				
Nozzle - 100 PSIG pump pressure (Delavan)	1.00 - 70W	1.10 - 70W		1.25 - 70W	
ELECTRICAL SYSTEM					
Volts - Hertz - Phase	115 - 60 - 1				
Operating voltage range	104 - 132				
Rated voltage (Amps)	16.4				
Minimum ampacity for wiring sizing	19.1				
Max. fuse size (Amps)	20				
BLOWER DATA					
Blower speed at 0.4" W.C. static pressure	MED-LO	MED-HI	HIGH	HIGH	HIGH
Blower speed at 0.2" W.C. static pressure	MED-LO	MED-HI	MED-HI	HIGH	HIGH
Motor / number of speeds	3/4 HP / 4 speeds				
Blower wheel size	12" x 9"				
Filter quantity and size	(2) 15" x 20"				

TABLE 4.3

Air delivery - CFM with air filter

SPEED	LBO145DABR34-D & OLR182A16C	
	EXTERNAL STATIC PRESSURE WITH AIR FILTER	
	0.2"	0.4"
MED-LO	1,725	1,600
MED-HI	1,850	1,725
HI	1,975	1,850

TABLE 3.4
Technical specifications, FLO115DABR-C and OLF140C12C (BECKETT, RIELLO AND AERO BURNERS)

RATING AND PERFORMANCE			
Firing rate USGPH	0.75	0.85	1.00
Input (BTU/h)	105,000	119,000	140,000
Heating capacity (BTU/h)	84,525	95,795	112,700
Maximum heating temperature rise	13°C - 29°C (55 - 85 Degr.F)		
BURNER BECKETT (3450 RPM)	AFG-F3 (TUBE INSERTION 5 3/16")		
Low firing rate baffle	YES		
Static disc, model	2 3/4 #3383		
Nozzle - 100 PSIG pump pressure (Delavan)	0.75 - 70W	0.85 - 70W	1.00 - 70W
Combustion air adjustment (band / shutter)	0 / 5	0 / 7	1 / 5
RIELLO BURNER; MODEL 40	F3 (TUBE INSERTION 5 1/4")		
Nozzle (Delavan)	0.60 - 60W	0.75 - 060W	0.85 - 60W
Pump pressure (PSIG)	155	130	140
Combustion air adjustment (turbulator / damper)	1.5 / 2.75	2.5 / 3.25	3 / 4.25
AERO BURNER (1725 RPM)	FAFC-2 (TUBE INSERTION 5 3/8")		
Nozzle - 100 PSIG pump pressure (Delavan)	0.75 - 70W	0.85 - 70W	1.00 - 70W
ELECTRICAL SYSTEM			
Volts - Hertz - Phase	115 - 60 - 1		
Operating voltage range	104 - 132		
Rated voltage (Amps)	14.7		
Minimum ampacity for wiring sizing	16.8		
Max. fuse size (Amps)	20		
BLOWER DATA			
Blower speed at 0.4" W.C. static pressure	MED-LO	MED-HI	HIGH
Blower speed at 0.2" W.C. static pressure	MED-LO	MED-HI	HIGH
Motor / number of speeds	1/2 HP / 4 speeds		
Blower wheel size	10" x 10"		
Filter quantity and size	(1) 10" x 20" & (1) 20" x 20"		

TABLE 4.4
Air delivery - CFM with air filter

SPEED	FLO115DABR-C & OLF140C12C	
	EXTERNAL STATIC PRESSURE WITH AIR FILTER	
	0.2"	0.4"
MED-LO	1,225	1,075
MED-HI	1,450	1,275
HIGH	1,550	1,375

FIGURE 4.1
Model: MBO115DABR-D

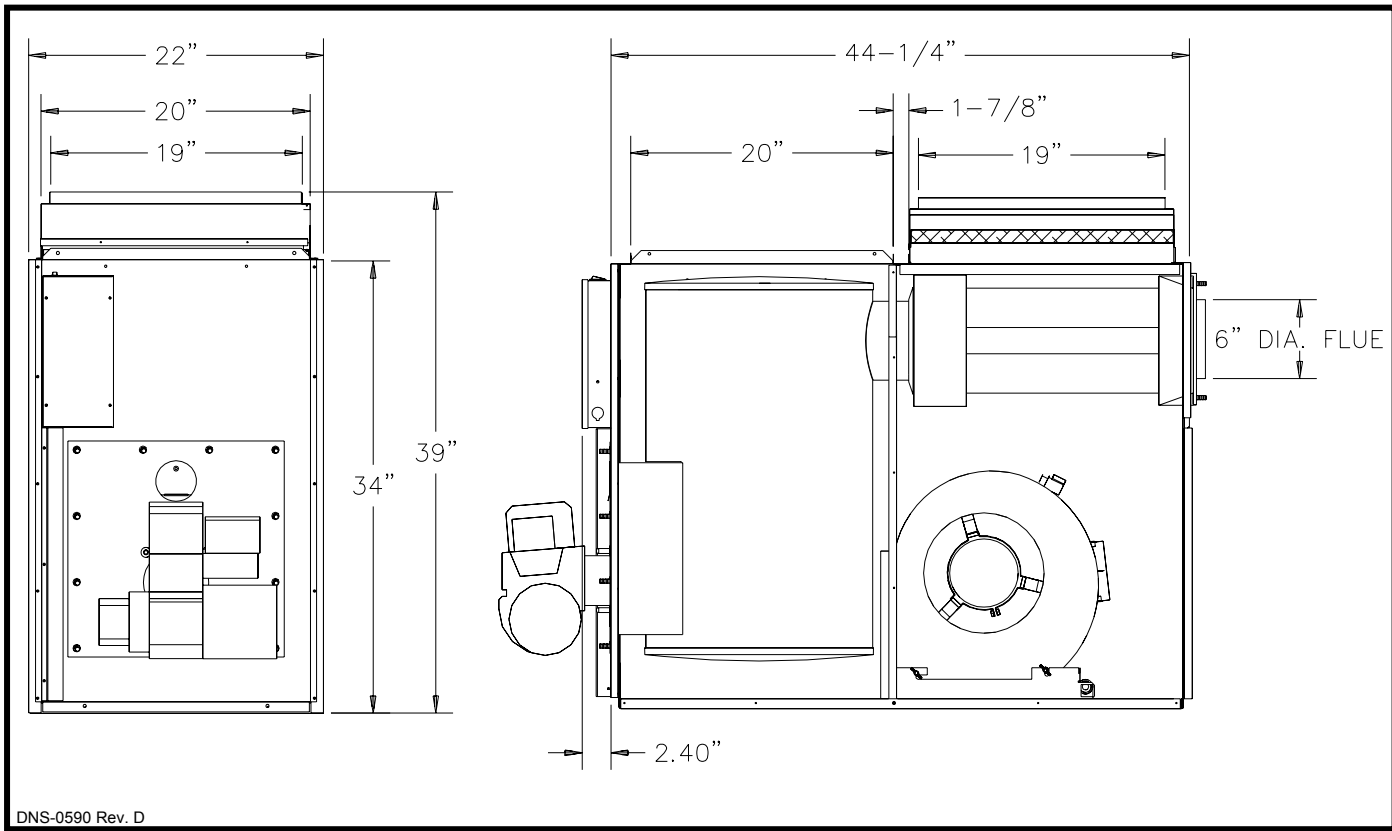

FIGURE 4.2
Model: MBOV115DABR-D

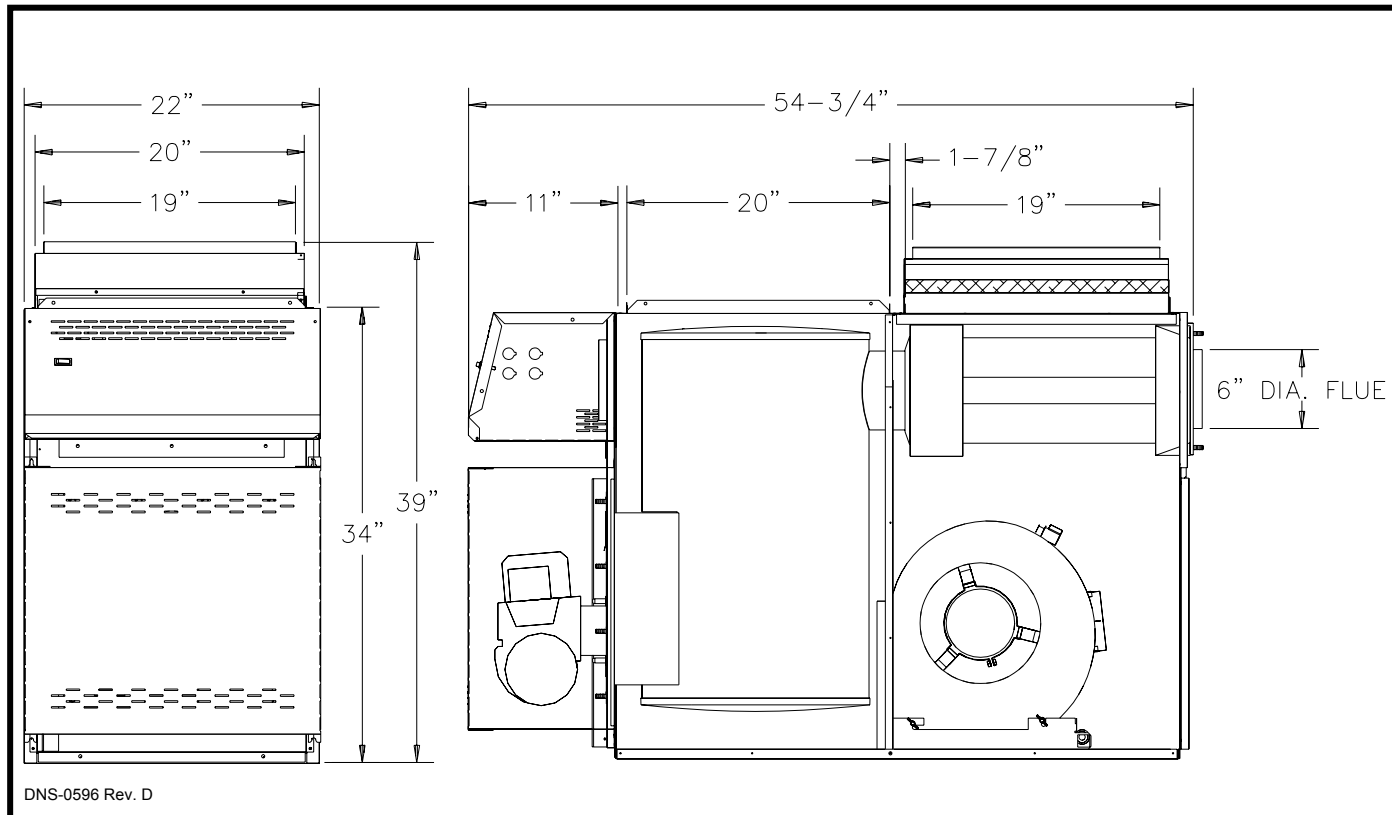
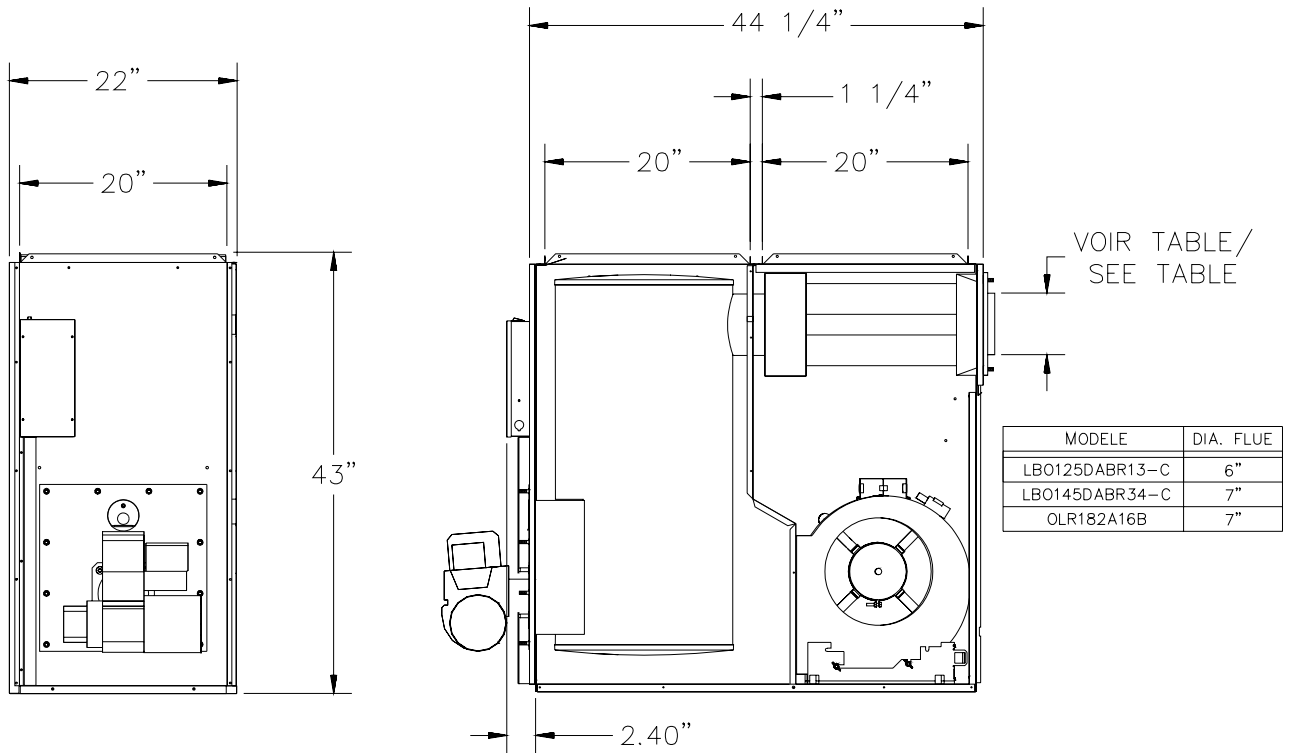
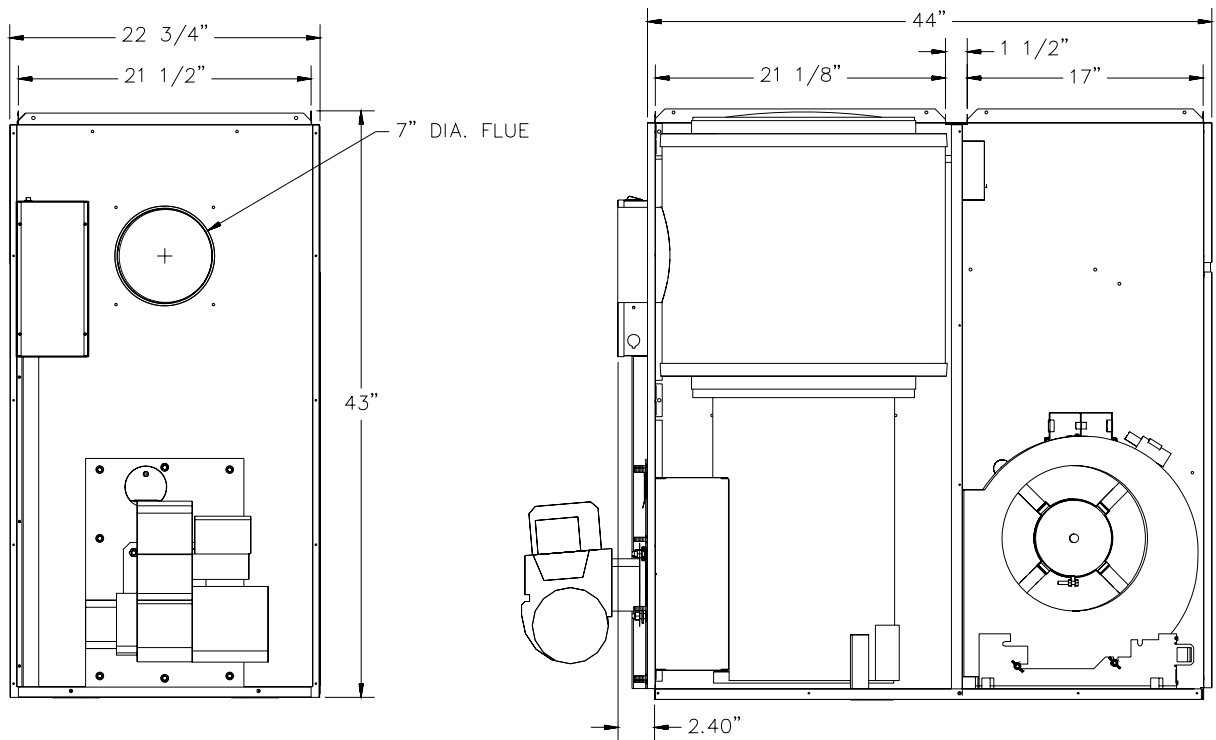

FIGURE 4.3
Models: LBO125DABR13-D, LBO145DABR34-D & OLR182A16C



DNS-0576 Rev. F

FIGURE 4.4
Model: FLO115DABR-C & OLF140C12C



DNS-0666 Rev. C

FIGURE 5

Wiring diagram, MBO115DABR-D, MBOV115DABR-D, LBO125DABR13-D,
LBO145DABR34-D & OLR182A16C, FLO115DABR-C & OLF140C12C

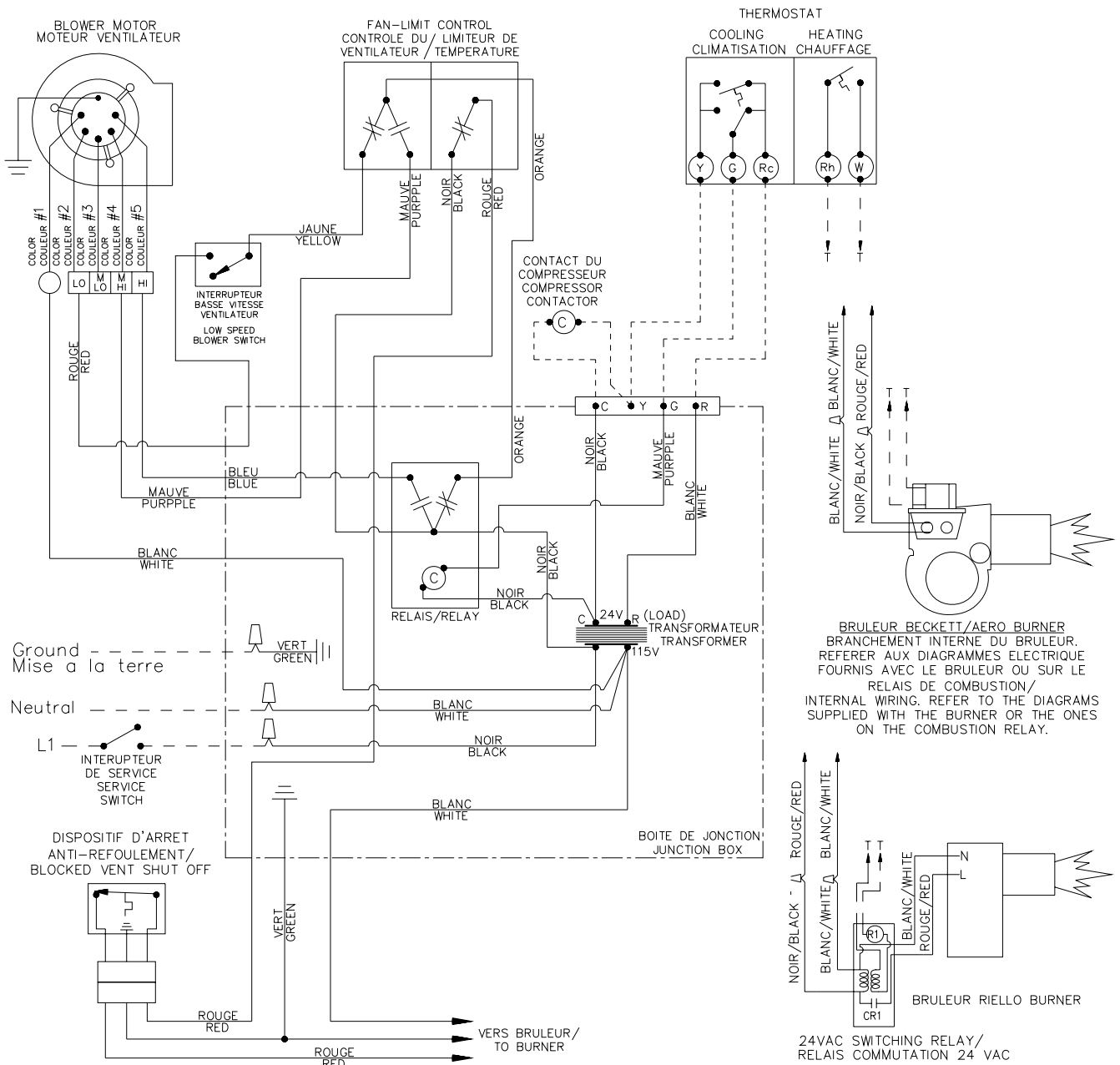

Ground
Mise à la terre

Neutral

L1
Interrupteur de Service
Service Switch

DISPOSITIF D'ARRET
ANTI-REFOULEMENT/
BLOCKED VENT SHUT OFF

- FACTORY WIRING (115 VOLTS)
CABLAGE EN USINE (115 VOLTS)
- - - WIRING BY OTHERS (HEATING ONLY)
CABLAGE PAR L'INSTALLATEUR (CHAUFFAGE SEULEMENT)
- - - - WIRING BY OTHERS (WITH A/C UNIT)
CABLAGE PAR L'INSTALLATEUR (AVEC UNITE A/C)

COLOUR CODES FOR BLOWER MOTOR CODE DE COULEUR POUR MOTEUR VENTILATEUR		
COLOR/COULEUR	EMERSON	GE
#1	WHITE/BLANC	WHITE/BLANC
#2	RED/ROUGE	PURPLE/MAUVE
#3	BLUE/BLEU	RED/ROUGE
#4	ORANGE	BLUE/BLEU
#5	BLACK/NOIR	BLACK/NOIR

PARTS LIST
Model: MBO115DABR-D

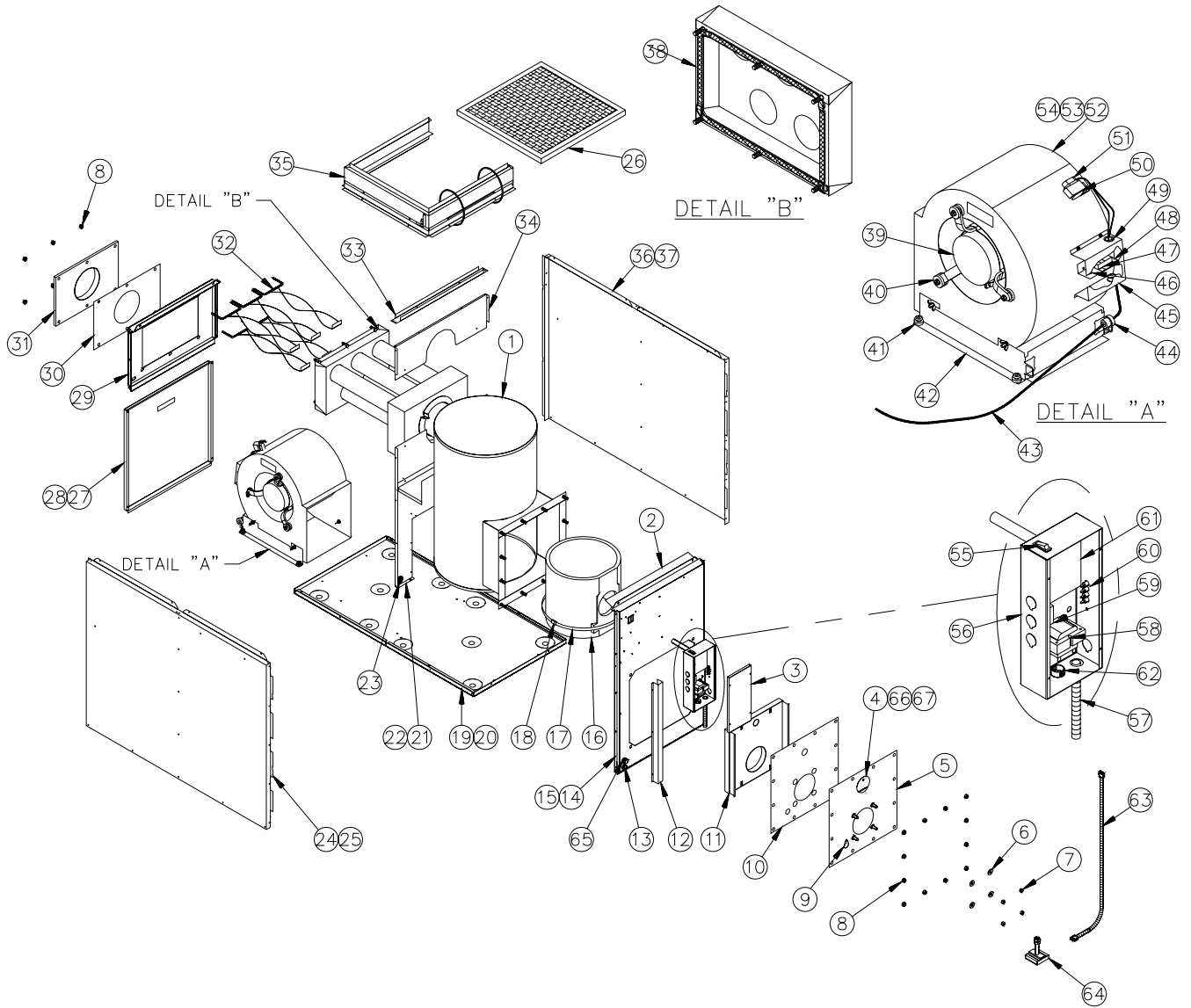

PARTS LIST
Model: MBO115DABR-D

ITEM	PART #	DESCRIPTION	COMMENTS
1	B40119-01	Complete heat exchanger	Item 16 included; item 38 not included
2	B40067	Top baffle	
3	B40466-01	Electrical box cover assembly	Wiring diagram label included
4	B02282	Observation door	
5	B40048	Burner panel assembly	Items 4 and 9 included
6	F06F005	Washer 3/8" AA zinc	4 required
7	F07F024	Hexagonal nut 3/8-16NC brass	4 required
8	F07O001	Hexagonal flange nut 3/8-16NC brass	18 required
9	B40120	Air supply door	
10	B40030	Gasket, burner panel	
11	B40099	Heat shield assembly	Insulation included
12	B40070-02	Corner conduit	
13	L04I013	Strain relief bushing	
14	B40130-01	Front panel assembly	Item 15 included
15	B40126	Front panel insulation	
16	B40160	Combustion chamber assembly	
17	B00891-50	Strap 10' x 1/2"	
18	Z05F009	Combustion chamber strap seal	
19	B40129	Floor assembly	Item 20 included
20	B01526-78	Floor insulation	
21	B40133	Division panel assembly	Central support, rear baffle and item 22 included
22	B01291-02	Seal strip	3 required
23	L04G005	Bushing 1 3/8"	
24	B40131-02	Left side panel assembly	Items 25 and 35 included
25	B40125-02	Left side panel insulation	
26	Z04F004	Paper filter 20 x 20 x 1	
27	B40132	Blower door assembly	Item 28 included
28	Z99F050	Door handle	
29	B40492	Top rear panel	
30	B40032	Gasket, smoke outlet	
31	B40046	Smoke outlet assembly	
32	B40054-01	Baffle assembly	5 required
33	B40043	Plenum divider	
34	B40076	Top division panel	
35	B40410	Filter rack assembly	
36	B40131-01	Right side panel assembly	Item 37 included
37	B40125-01	Right side panel insulation	
38	J06L002	Seal Strip 1/2" x 1/8" x 25'	
39	L06G011	Motor, 1/3 HP DD 4V	
40	B01888	Motor mount assembly	Legs, band and screws included
41	Z01F006	Rubber grommet	4 required
42	B01756	Blower support bracket	
43	B40456	Blower electrical kit	
44	L04I010	Strain relief bushing	
45	B40059	Terminal strip cover	Item 49 not included
46	L03J005	Terminal plug-in .250"	
47	L99F003	Terminal block 4 positions	
48	B40074	Terminal strip support	
49	L04G013	Bushing 7/8"	2 required
50	B01024	Capacitor holder	
51	L01I003	Capacitor 10 MF	
52	B40135-01	Blower assembly replacement 1/3 HP	Items 39 to 54 included
53	Z01I001	Blower G10-10DD	Housing and wheel included
54	Z01L004	Blower wheel G10-10DD	
55	L07F003	Rocker switch SPST	
56	B40454	Electrical box	Box only
57	B40455	Burner electrical kit	
58	L01F009	Transformer 120-24 Volts, 40VA	
59	L01H009	Relay SPDT 24 VAC	
60	L05F009	Terminal strip, 4 positions	
61	R02I007	Fan Limit Control 5"	
62	L04G006	Bushing 1"	
63	B03118-01	Electrical kit for BVSO	
64	Z06G001	Blocked vent shut off BVSO-225	
65	L04I005	Strain relief bushing	
66	A00183-01	Observation door spring	
67	F03F023	Screw #F hexwsh 1/4-20 x 1 1/4	

PARTS LIST
Model: MBOV115DABR-D

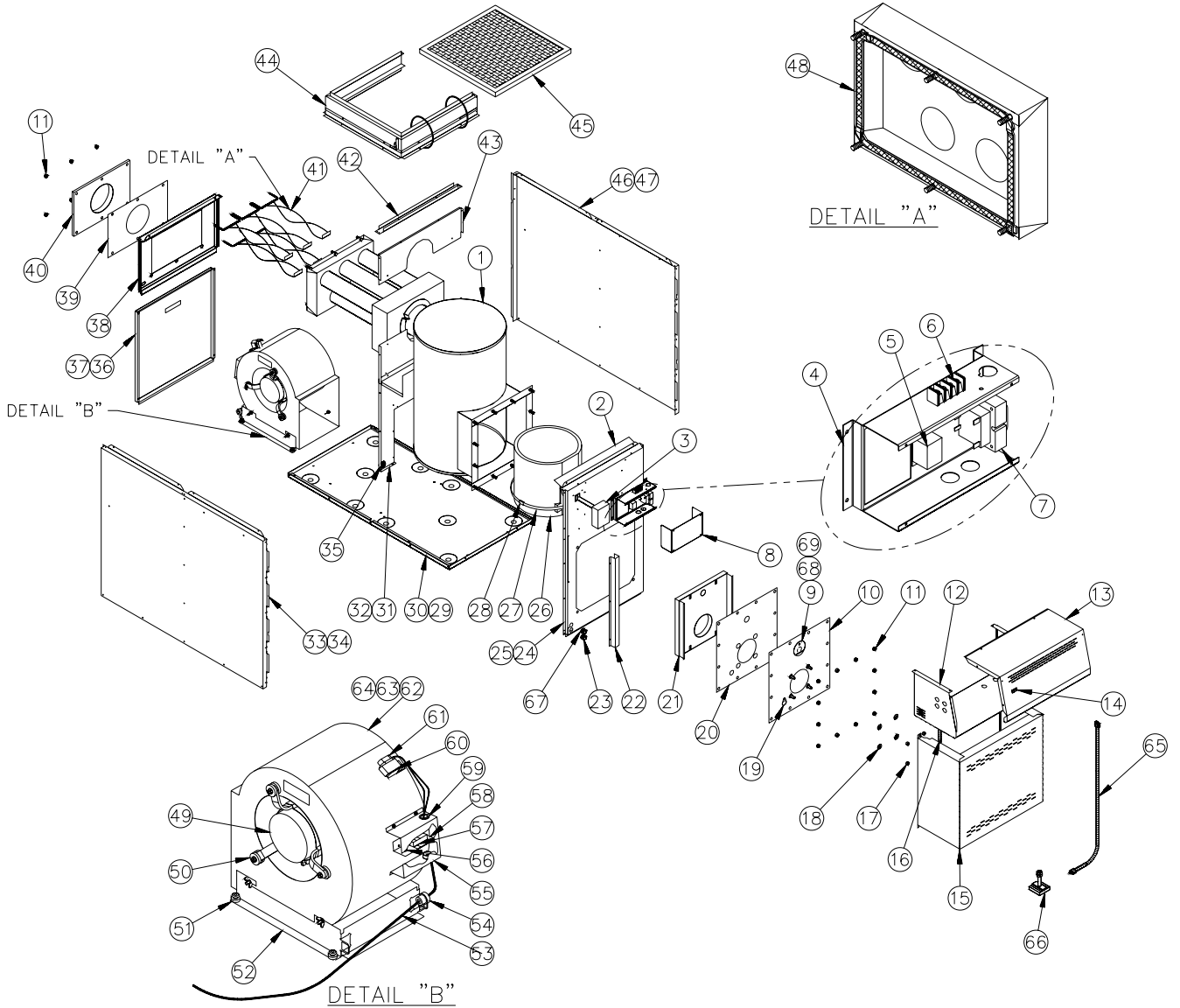

PARTS LIST
Model: MBOV115DABR-D

ITEM	PART #	DESCRIPTION	COMMENTS
1	B40119-01	Complete heat exchanger	Item 24 included; item 46 not included
2	B40067	Top baffle	
3	R02I007	Fan Limit Control L6064A	
4	B40460	Component panel	Items 5, 6 and 7 not included
5	L01H009	Relay SPDT 24 VAC	
6	L05F009	Terminal strip, 4 positions	
7	L01F009	Transformer 120-24 VAC, 40 VA	
8	B40464-01	Electrical box cover	
9	B02282	Observation door	
10	B40048	Burner panel assembly	Items 7 and 14 included
11	F07O001	Hexagonal flange nut 3/8-16NC brass	18 required
12	B40140	Electrical box assembly	Box only
13	B40463-02	Electrical cover assembly	Item 14 not included, labels included
14	L07F003	Rocker switch	
15	B40148	Vestibule burner assembly	
16	B40455	Burner electrical kit	
17	F07F024	Hexagonal nut 3/8-16NC brass	4 required
18	F06F005	Washer 3/8" AA zinc	4 required
19	B40120	Air supply door	
20	B40030	Gasket, burner panel	
21	B40099	Heat shield assembly	Insulation included
22	B40070-01	Corner conduit	
23	L04I013	Strain relief bushing	
24	B40146	Front panel assembly	Item 25 included
25	B40126	Front panel insulation	
26	B40160	Combustion chamber	
27	B00891-50	Strap 10' x 1/2"	
28	Z05F009	Combustion chamber strap seal	
29	B40129	Floor assembly	Item 30 included
30	B01526-78	Floor insulation	
31	B40133	Division panel assembly	Central support, rear baffle and item 32 included
32	B01291-02	Seal strip	3 required
33	B40131-02	Left side panel assembly	Item 34 included
34	B40125-02	Left side panel insulation	
35	L04G005	Bushing 1 3/8"	
36	B40132	Blower door assembly	Item 37 included
37	Z99F050	Door handle	
38	B40492	Top rear panel	
39	B40032	Gasket, smoke outlet	
40	B40046	Smoke outlet assembly	
41	B40054-01	Baffle assembly	3 required
42	B40043	Plenum divider	
43	B40076	Top division panel	
44	B40410	Filter rack assembly	
45	Z04F004	20 X 20 X 1 paper filter	
46	B40131-01	Right side panel assembly	Item 47 included
47	B40125-01	Right side panel insulation	
48	J06L002	Seal strip 1/4" X 1/8" x 25'	
49	L06G011	1/3 HP direct drive motor	
50	B01888	Motor mount assembly	Legs, band and screws included
51	Z01F006	Rubber grommet	4 required
52	B01756	Blower support bracket	
53	B40456	Blower electrical kit	
54	L04I010	Strain relief bushing	
55	B40059	Terminal strip cover	Item 57 not included
56	L03J005	Terminal plug-in 0.250	
57	L99F003	Terminal block 4 positions	
58	B40074	Terminal strip support	
59	L04G013	Bushing 7/8"	1 required
60	B01024	Capacitor holder	
61	L01I003	10 MF capacitor	
62	B40135-01	Blower assembly	Items 49 to 64 included
63	Z01I001	Blower 10 X 10	Housing and wheel included
64	Z01L004	Blower wheel 10 X 10	
65	B03118-01	Electrical kit for BVSO	
66	Z06G001	Blocked vent shut off BVSO	
67	L04I005	Strain relief bushing	
68	A00183-01	Observation door spring	
69	F03F023	Screw #F hex wsh 1/4-20 x 1 1/4	

PARTS LIST
Model: LBO125DABR13-D

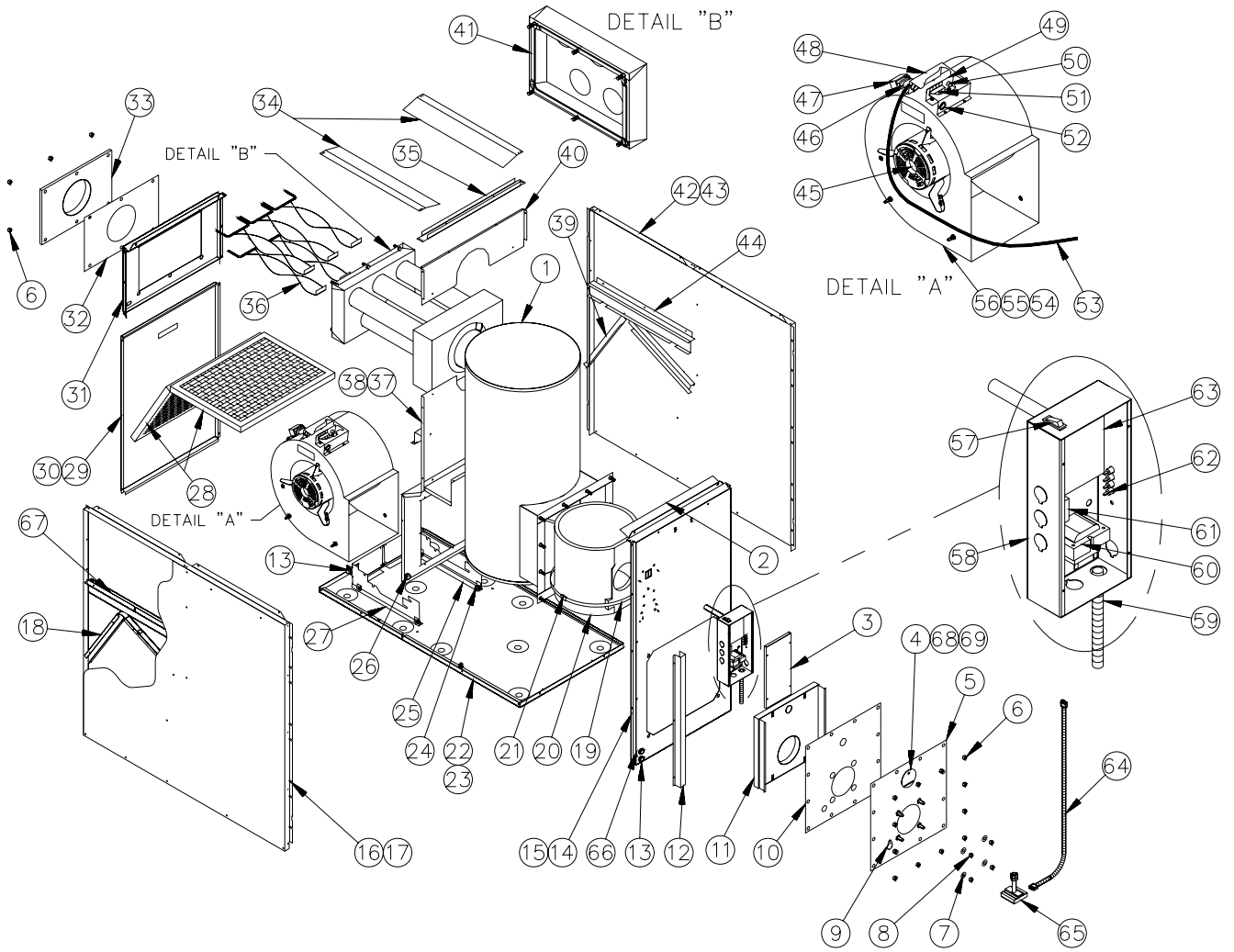

PARTS LIST
Model: LBO125DABR13-D

ITEM	PART #	DESCRIPTION	COMMENTS
1	B40117-01	Complete heat exchanger	Item 20 included; item 41 not included
2	B40067	Top baffle	
3	B40466-01	Electrical box cover assembly	"Electrical Diagram" label included
4	B02282	Observation door	
5	B40048	Burner panel assembly	Items 4 and 9 included
6	F07O001	Hexagonal flange nut 3/8-16NC brass	18 required
7	F06F005	Washer 3/8" AA zinc	4 required
8	F07F024	Hexagonal nut 3/8-16NC brass	4 required
9	B40120	Air supply door	
10	B40030	Gasket, burner panel	
11	B40099	Heat shield assembly	Insulation included
12	B40070-01	Corner conduit	
13	L04I013	Strain relief bushing	
14	B40105-01	Front panel assembly	Item 15 included
15	B40096	Front panel insulation	
16	B40362-02	Left side panel assembly	Items 17, 18 and 44 included
17	B40095-02	Left side panel insulation	
18	B40494	Filter support	
19	B00891-50	Strap 10' x 1/2"	
20	B40160	Combustion chamber	
21	Z05F009	Combustion chamber strap seal	
22	B40111-01	Floor assembly	Item 23 included
23	B01526-77	Floor insulation	
24	Z01F006	Rubber grommet	4 required
25	B40072-02	Blower support bracket	
26	L04G012	Bushing 1"	
27	B40072-01	Blower support bracket	
28	Z04F012	Paper filter 15 x 20 x 1	2 required
29	B40107	Blower door assembly	Item 30 included
30	Z99F050	Door handle	2 required
31	B40492	Top rear panel	
32	B40032	Gasket, smoke outlet	
33	B40046	Smoke outlet assembly	
34	B40071	Inlet baffle	2 required
35	B40043	Plenum divider	
36	B40054-01	Baffle assembly	5 required
37	B40108	Division panel assembly	Central support, rear baffle and item 38 included
38	B01291-02	Seal strip	4 required
39	B40229-01	Right angle filter support	
40	B40076	Top division panel	
41	J06L001	Seal strip 1/2 x 1/8 x 25'	
42	B40362-01	Right side panel assembly	Items 39, 43 and 44 included
43	B40095-01	Right side panel insulation	
44	B40028	Horizontal filter support	
45	L06G011	1/3 HP direct drive motor	
46	L01I003	10 MF capacitor	Legs, band and screws included
47	B01024	Capacitor holder	
48	B40059	Terminal strip cover	Item 53 not included
49	B40074	Terminal strip	Items 51 and 52 not included
50	L03J005	Terminal plug-in .250	
51	L99F003	Terminal block	
52	L04G013	Bushing 7/8"	2 required
53	B40456	Blower electrical kit	
54	B40467-01	Blower assembly	Items 45 to 57 included
55	Z01I001	Blower 10 X 10	Housing and wheel included
56	Z01L004	Blower wheel 10 X 10	
57	L07F003	Rocker switch SPST	
58	B40454	Electrical box	Box only
59	B40455	Burner electrical kit	
60	L01F009	Transformer 120-24 VAC, 40 VA	
61	L01H009	Relay SPDT 24VAC	
62	L05F009	Terminal strip, 4 positions	
63	R02I007	Fan Limit control L6064A	
64	B03118-01	Electrical kit for BVSO	
65	Z06G001	Blocked Vent Shut Off (BVSO)	
66	L04I005	Strain relief bushing	
67	B40495	Horizontal filter support	
68	A00183-01	Observation door spring	
69	F03F023	Screw #F hex wsh 1/4-20X1 1/4	

→

PARTS LIST

Models: LBO145DABR34-D & OLR182A16C

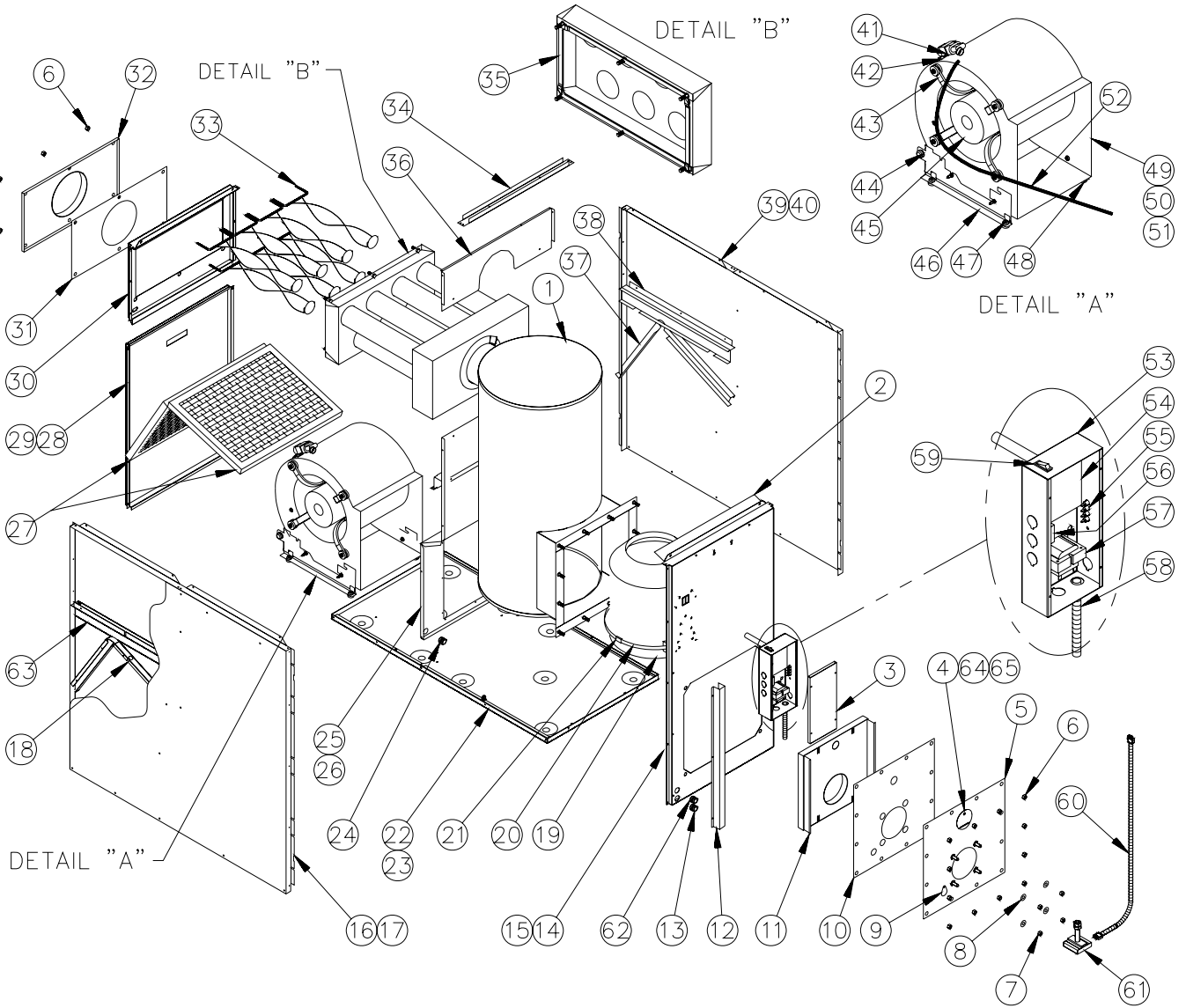

PARTS LIST
Models: LBO145DABR34-D & OLR182A16C



ITEM	PART #	DESCRIPTION	COMMENTS
1	B40118-01	Complete heat exchanger	Item 19 included; item 35 not included
2	B40067	Top baffle	
3	B40466-01	Electrical box cover assembly	Wiring diagram label included
4	B02282	Observation door	
5	B40048	Burner panel assembly	Items 4 and 9 included
6	F07O001	Hexagonal flange nut 3/8-16NC brass	18 required
7	F07F024	Hexagonal nut 3/8-16NC brass	4 required
8	F06F005	Washer 3/8" AA zinc	4 required
9	B40120	Air supply door	
10	B40030	Gasket, burner panel	
11	B40099	Heat shield assembly	Insulation included
12	B40070-01	Corner conduit	
13	L04I013	Strain relief bushing	
14	B40105-01	Front panel assembly	Item 15 included
15	B40096	Front panel insulation	
16	B40362-02	Left side panel assembly	Items 17, 18 and 38 included
17	B40095-02	Left side panel insulation	
18	B40494	Left filter support	
19	B40161	Combustion chamber	
20	B00891-50	Strap 10' x 1/2"	Sold in feet
21	Z05F009	Combustion chamber strap seal	
22	B40111-02	Floor assembly	Item 23 included
23	B01526-77	Floor insulation	
24	L04G012	Bushing 1"	
25	B40109	Division panel assembly	Central support, rear baffle and item 26 included
26	B01291-02	Seal strip	4 required
27	Z04F012	Paper filter 15" x 20" x 1"	2 required
28	B40107-01	Blower door assembly	Item 29 included
29	Z99F050	Door handle	
30	B40497	Top rear panel	
31	B40031	Gasket, smoke outlet	
32	B40047	Smoke outlet	
33	B40054-02	Baffle assembly	7 required
34	B40043	Plenum divider	
35	J06L001	Seal strip 1/2" x 1/8" x 25'	
36	B40076	Top division panel	
37	B40299-01	Right angle filter panel	
38	B40028	Horizontal filter support	2 required
39	B40362-01	Right side panel assembly	Items 37, 38 and 40 included
40	B40095-01	Right side panel insulation	
41	B01024	Capacitor holder	
42	L01I005	Capacitor 15 MF	
43	B40134	Belly band assembly	Legs, belly band and screws included
44	L04I013	Strain relief bushing	
45	B40113-02	Motor 3/4 HP DD	
46	B40072-02	Blower support bracket	
47	Z01F006	Rubber grommet	4 required
48	B40072-01	Blower support bracket	
49	Z01L010	Blower wheel 12-9DD	
50	Z01I015	Blower 120-9TDD	Housing and wheel included
51	B40468-01	Blower assembly (3/4 HP motor)	Items 41, 42, 44, 45, 46, 47, 48, 50 included
52	B40499	Blower electrical kit	
53	B40454	Electrical box	Box only
54	R02I007	Fan Limit Control 5"	
55	L05F009	Terminal strip, 4 positions	
56	L01H009	Relay SPDT 24VAC	
57	L01F009	Transformer 120-24 VAC, 40 VA	
58	B40455	Burner electrical kit	
59	L07F003	Rocker switch SPST	
60	B03118-01	Electrical kit for BVSO	
61	Z06G001	Blocked vent shut off BVSO	
62	L04I005	Strain relief bushing	
63	B40495	Horizontal filter support	
64	A00183-01	Observation door spring	
65	F03F023	Screw #F hex wsh 1/4-20 x 1 1/4	



PARTS LIST
Model: FLO115DABR-C & OLF140C12C

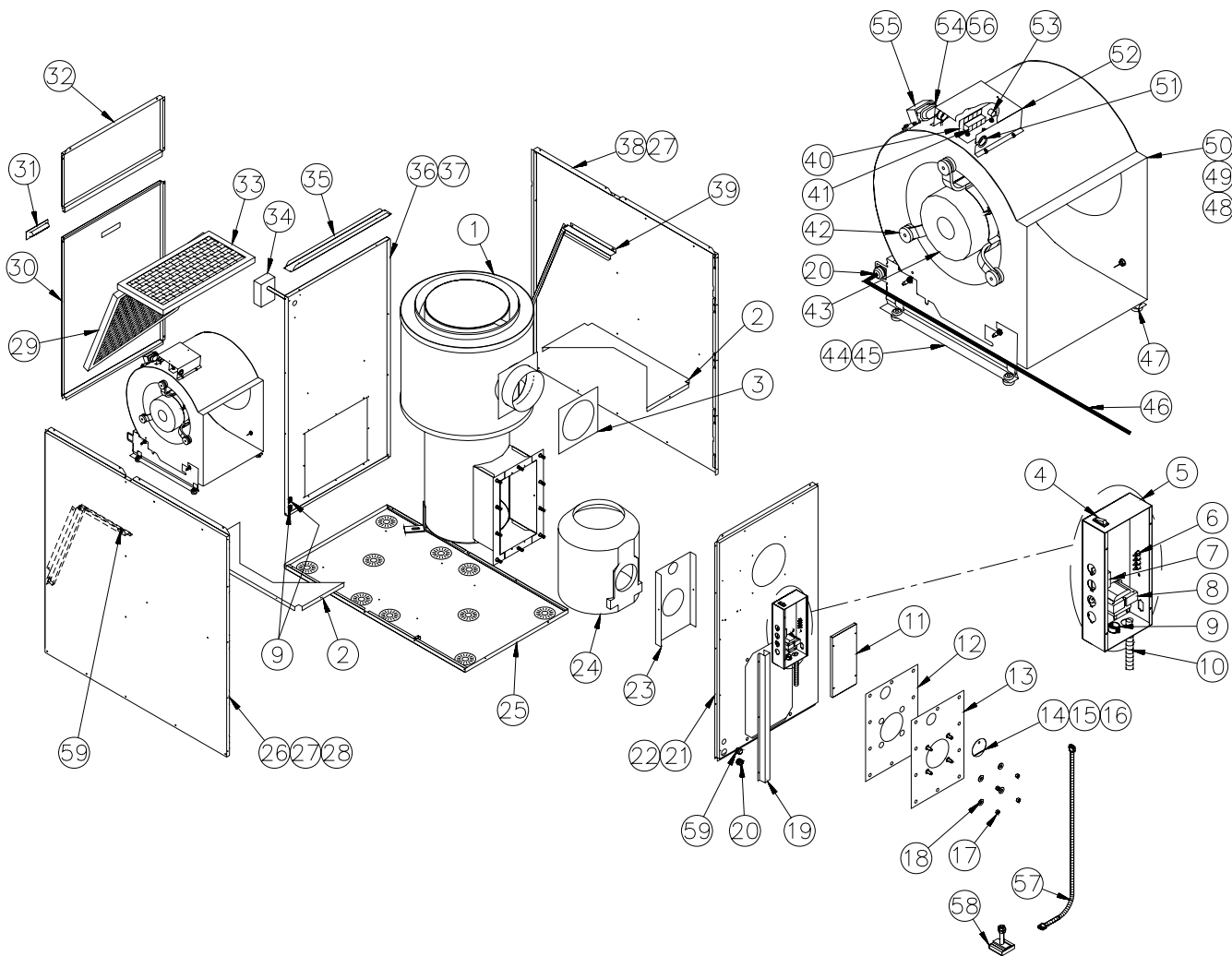

PARTS LIST
Model: FLO115DABR-C & OLF140C12C

ITEM	PART #	DESCRIPTION	COMMENTS
1	B40385	Heat exchanger	Combustion chamber included
2	B40358	Side deflector	2 required
3	B40360	Gasket, smoke outlet	
4	L07F003	Rocker switch SPST	
5	B40491	Electrical box	Box only
6	L05F009	Single terminal strip	
7	L01H009	Relay SPDT 24 VAC	
8	L01F009	Transformer 120-24 V, 40 VA	
9	L04G006	Bushing 1"	
10	B40455	Burner electrical kit	
11	B40470	Electrical box cover	
12	B40359	Gasket, burner panel	
13	B40376	Burner panel	
14	B02282	Observation door	
15	A00183-01	Observation door spring	
16	F03F023	Vis TYP F Hex 1/4-20 x 11/4	
17	F07F011	Hex nut 3/8-16NC zinc	
18	F06F005	Washer 3/8 zinc	
19	B40070-01	Corner conduit	
20	L04I010	Strain relief bushing	
21	B40378-01	Front panel	Insulation included
22	B40379	Front panel insulation	
23	B40371	Heat shield	
24	B40161	Combustion chamber	
25	B40383	Floor assembly	
26	B40380-02	Left side panel assembly	
27	B01526-82	Side panel insulation	
28	B40374-02	Left filter rack	
29	Z04F004	Paper filter 20" x 20" x 1"	1 required
30	B40381	Blower door assembly	Item 31 included
31	Z99F050	Acces door	
32	B40356	Top back panel assembly	
33	Z04F001	Paper filter 10" x 20" x 1"	1 required
34	R02I007	Fan Limit 5"	
35	B40353	Plenum divider	
36	B40382	Divider panel assembly	Item 37 included
37	B01291-02	Seal strip	4 required
38	B40380-01	Right side panel assembly	
39	B40374-01	Right filter rack	
40	B40074	Terminal strip support	
41	L99F003	Terminal block 6 positions	
42	Z01I016	Motor mount	3 required
43A	B40112-02	Motor 1/2 HP with support	"Motor mount" included
43B	L06H007	Motor 1/2 HP	
44	B40072-02	Left blower support	
45	B40072-01	Right blower support	
46	B40456	Blower, electrical kit	
47	Z01F006	Grommet	
48	B40469	Blower assembly	Complete with motor
49	Z01I001	Blower G10-10DD	Housing & wheel included
50	Z01L004	Blower wheel 10" x 10"	
51	L04G013	Bushing 7/8 "	
52	B40059	Terminal strip cover	
53	L03J005	Terminal plug-in 1/4	
54	L01I003	10 MF capacitor	
55	B01024	Capacitor holder	
56	L99Z007	Rubber cap capacitor	
57	B03118-01	Electrical kit BVSO	
58	Z06G001	Blocked vent shut off BVSO	
59	L04I013	Strain relief bushing	
60	L04G012	Bushing 1"	