

Installation Instructions and Homeowner's Manual

LOW BOY OIL FIRED FURNACE

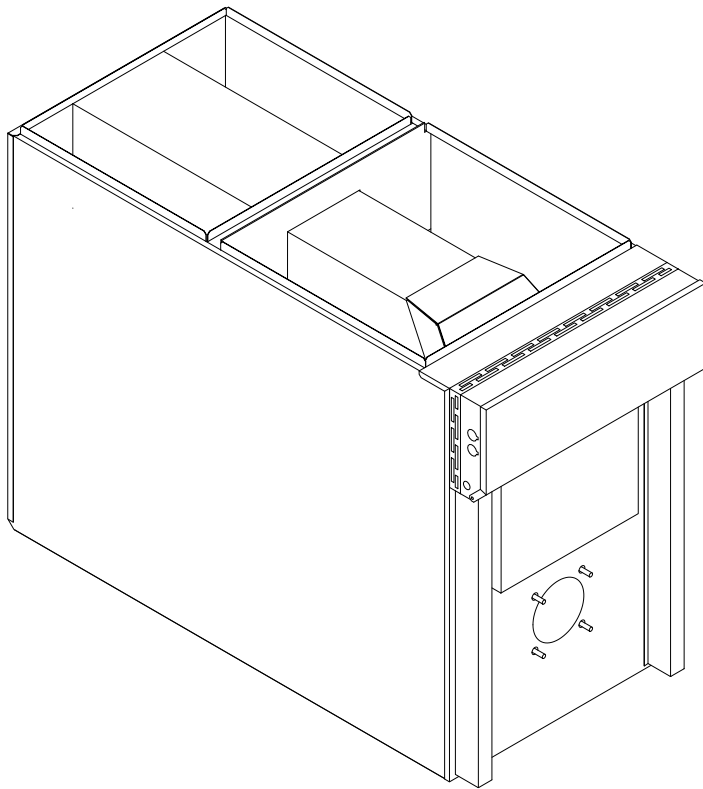

DNS-1161 Rev.A

INSTALLER / SERVICE TECHNICIAN:

USE THE INFORMATION IN THIS MANUAL FOR THE INSTALLATION / SERVICING OF THE FURNACE AND KEEP THE DOCUMENT NEAR THE UNIT FOR FUTURE REFERENCE.

HOMEOWNER:

PLEASE KEEP THIS MANUAL NEAR THE FURNACE FOR FUTURE REFERENCE.

MODELS:

OLR112A16A
OLV112A16A



Use of the AHRI Certified TM Mark indicates a manufacturer's participation in the program. For verification of certification for individual products, go to www.ahrirectory.org.

Attention:

Do not tamper with the unit or its controls. Call a qualified service technician.

Manufactured by:

Dettson Industries inc.
3400 Industrial Boulevard
Sherbrooke, Qc, Canada J1L 1V8
www.dettson.ca

TABLE OF CONTENTS

1	SAFETY REGULATIONS	3
1.1	SAFETY LABELING AND WARNING SIGNS	3
1.2	IMPORTANT INFORMATION	3
1.3	DETECTION SYSTEMS.....	3
1.4	DANGER OF FREEZING	3
2	INSTALLATION.....	4
2.1	POSITIONING THE FURNACE.....	4
2.2	ELECTRICAL SYSTEM	4
2.4	INSTALLATION OF THE BURNER	5
2.5	VENTING.....	5
2.6	BLOCKED VENT SHUT-OFF DEVICE (BVSO) FOR CHIMNEY VENTING	6
2.7	COMBUSTION AIR SUPPLY AND VENTILATION	6
2.8	OIL TANK	7
2.9	DUCTING.....	7
2.10	SUPPLY AIR ADJUSTMENTS (4 SPEED MOTOR)	7
2.11	SUPPLY AIR ADJUSTMENTS (ECM VARIABLE SPEED MOTORS).....	8
2.12	INSTALLATION OF ACCESSORIES.....	8
3	OPERATION	9
3.1	START-UP	9
3.2	OPERATING SEQUENCE OIL HEATING MODE ..	9
3.3	CHECKS AND ADJUSTMENTS.....	9
4	MAINTENANCE.....	11
4.1	CLEANING THE HEAT EXCHANGER	11
4.2	CLEANING THE BLOCKED VENT SHUT-OFF DEVICE (BVSO).....	11
4.4	CHANGING THE NOZZLE.....	11
4.5	CHANGING THE OIL FILTER	11
4.6	CHANGING THE AIR FILTER	11
5	FURNACE INFORMATION	12

FIGURES

Figure 1: Location and dimensions of ventilation air openings in a closet door.....	4
Figure 2: Thermostat wiring, heating and air conditioning with 4 speed motor	5
Figure 3: Thermostat wiring, heating and air conditioning with ECM variable speed motor.....	5
Figure 4: Thermostat wiring, heating and air conditioning/heat pump with ECM variable speed motor	5
Figure 5: Supply air adjustments, start/stop delays, board #1158	8
Figure 6: Furnace dimensions	16
Figure 7: Wiring diagram, 4 speed motor (PSC).....	17
Figure 8: Wiring diagram, variable speed motor (ECM) ..	18
Figure 9: Parts list with 4 speed motor (PSC)	19
Figure 10: Parts list with variable speed motor (ECM).....	21

TABLES

Table 1: Supply air adjustments, heating mode, 4 speed motor	7
Table 2: Supply air adjustments, A/C mode, 4 speed motor	8
Table 3: Supply air adjustments, heating mode, variable speed motor (ECM).....	8
Table 4: Supply air adjustments, air conditioning mode, variable speed motor (ECM).....	8
Table 5: Supply air adjustments, all modes, variable speed motor (ECM).....	8
Table 6: Delay adjustments, heating mode, variable speed motor (ECM).....	8
Table 7: Technical specifications.....	13
Table 8: Airflow data, models with 3/4 HP variable speed motors (ECM)	14
Table 9: Airflow data, models with 1/2 HP 4 speed motors	15
Table 10: Minimum clearances from combustible material	15
Table 11: Parts list with 4 speed motor (PSC)	20
Table 12: Part lists with variable speed motor (ECM)	22

1 SAFETY REGULATIONS

1.1 SAFETY LABELING AND WARNING SIGNS

The words DANGER, WARNING AND CAUTION are used to identify the levels of seriousness of certain hazards. It is important that you understand their meaning. You will notice these words in the manual as follows:

	DANGER
Immediate hazards that <u>WILL</u> result in death, serious bodily injury and/or property damage.	

	WARNING
Hazards or unsafe practices that <u>CAN</u> result in death, bodily injury and/or property damage.	

	CAUTION
Hazards or unsafe practices that <u>CAN</u> result in bodily injury and/or property damage.	

1.2 IMPORTANT INFORMATION

	WARNING
Non-observance of the safety regulations outlined in this manual will potentially lead to consequences resulting in death, serious bodily injury and/or property damage.	

- a) It is the homeowner's responsibility to engage a qualified technician for the installation and subsequent servicing of this furnace;
- b) Do not use this furnace if any part of it was under water. Call a qualified service technician immediately to assess the damage and to replace all critical parts that were in contact with water;
- c) Do not store gasoline or any other flammable substances, such as paper, carton, etc. near the furnace;
- d) This furnace is designed for use with #1 or #2 heating oil only. The use of gasoline, motor oil or any other oil containing gasoline is prohibited;
- e) Never block or otherwise obstruct the filter and/or return air openings;
- f) Ask the technician installing your furnace to show and explain to you the following items:
 - i) The main disconnect switch;
 - ii) The shut-off valve on the oil tank;
 - iii) The oil filter and how to change it (must be changed once a year);
 - iv) The air filter and how to change it (check monthly and clean or replace if necessary.)

- g) Before calling for service, be sure to have the information page of your manual close by in order to be able to provide the contractor with the required information, such as the model and serial numbers of the furnace.

	WARNING
Installations and repairs performed by unqualified persons can result in hazards to them and to others. Installations must conform to local codes or, in the absence of same, to codes of the country having jurisdiction.	
The information contained in this manual is intended for use by a qualified technician, familiar with safety procedures and who is equipped with the proper tools and test instruments.	
Failure to carefully read and follow all instructions in this manual can result in death, bodily injury and/or property damage.	

1.3 DETECTION SYSTEMS

It is recommended that carbon monoxide detectors be installed wherever oil or gas fired heaters are used. Carbon monoxide can cause bodily harm or death. For this reason, agency approved carbon monoxide detectors should be installed in your residence and properly maintained to warn of dangerously high carbon monoxide levels.

There are several sources of possible smoke and flames in a residence. Smoke and flames can cause bodily harm or death. For this reason, agency approved smoke detectors should be installed in your residence and properly maintained, to warn early on, of a potentially dangerous fire. Also, the house should be equipped with approved and properly maintained fire extinguishers.

Your unit is equipped with safety devices that can prevent it from functioning when anomalies are detected such as a blocked venting system.

1.4 DANGER OF FREEZING

	CAUTION
If your furnace is shut down during the cold weather season, water pipes may freeze, burst and cause serious water damage. Turn off the water supply and bleed the pipes.	

If the heater is left unattended during the cold weather season, take the following precautions:

- a. Close the main water valve in the house and purge the pipes if possible. Open all the faucets in the house;
- b. Ask someone to frequently check the house during the cold weather season to make sure that there is sufficient heat to prevent the pipes from freezing. Tell this person to call an emergency number if required.

2 INSTALLATION

The unit is shipped with a burner and its controls. It requires a 115VAC power supply to the control panel and thermostat hook-up as shown on the wiring diagram, one or more oil line connections, suitable ductwork and connection to a properly sized vent.

All local and national code requirements governing the installation of oil burning equipment, wiring and the flue connection MUST be followed. Some of the codes that may apply are:

CSA B139: Installation code for oil burning equipment.

ANSI/NFPA 31: Installation of oil burning equipment.

ANSI/NFPA 90B: Warm air heating and air conditioning systems.

ANSI/NFPA 211: Chimneys, Fireplaces, Vents and solid fuel burning appliances.

ANSI/NFPA 70: National Electrical Code.

CSA C22.1 or CSA C22.10:
Canadian Electrical Code.

Only the latest issues of these codes may be used.

2.1 POSITIONING THE FURNACE



WARNING

Fire and explosion hazard.The furnace must be installed in a level position, never where it will slope toward the front. Do not store or use gasoline or any other flammable substances near the furnace. Non-observance of these instructions will potentially result in death, bodily injury and/or property damage.



CAUTION

This furnace is not watertight and is not designed for outdoor installation. It must be installed in such a manner as to protect its electrical components from water. Outdoor installation will lead to a hazardous electrical condition and to premature failure of the equipment.

The minimum clearances from combustible material for each of the positions are specified in Table 9.

If the furnace is installed in a basement or on a dirt floor, in a crawl space for example, it is recommended to install the unit on a cement base 2.5 cm to 5.0 cm (1" to 2") thick.

The unit must be installed in an area where the ambient and return air temperatures are above 15°C (60°F). In addition, the furnace should be installed as closely as possible to the vent, so that the connections are direct and kept to a minimum. The heater should also be located close to the centre of the air distribution system.

2.1.1 Installation in an enclosure

The unit can be installed in an enclosure such as a closet. However, 2 ventilation openings are required for combustion air. The openings should be located in front of the furnace approximately 15 cm (6") above the floor and 15 cm (6") below the ceiling. Figure 1 indicates the minimum dimensions required and the location of the openings.

Figure 1: Location and dimensions of ventilation air openings in a closet door

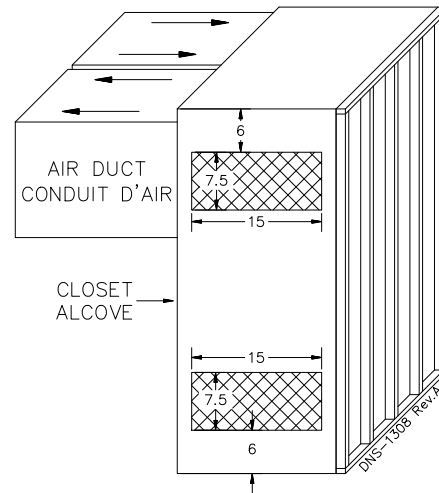

2.2 ELECTRICAL SYSTEM



CAUTION

The exterior of the unit must have an uninterrupted ground to minimize the risk of bodily harm, if ever an electrical problem develops. A green ground screw is supplied with the control box for that purpose.

The appliance must be installed in accordance with the current ANSI/NFPA 70 National Electrical Code, CSA C22.1 Canadian Electrical Code Part 1 and/or local codes.

The control system depends on the correct polarity of the power supply. Connect "HOT" wire (H) and "NEUTRAL" wire (N) as shown in Figures 7 and 8.

A separate line voltage supply should be used, with fused disconnect switch or circuit breaker, between the main power panel and the unit.

Only copper wire may be used for the 115V circuit on this unit. If wires need to be changed, the replacements must have the same temperature resistance as the originals.

2.3 INSTALLATION OF THE THERMOSTAT

A thermostat must be installed to control the temperature of the area to be heated. Follow the instructions supplied with the thermostat. Also refer to the wiring diagrams provided with the heating/air conditioning unit. The connections must be made as shown in the next figures. Also refer to electrical diagrams in Figures 7 and 8.

Figure 2: Thermostat wiring, heating and air conditioning with 4 speed motor

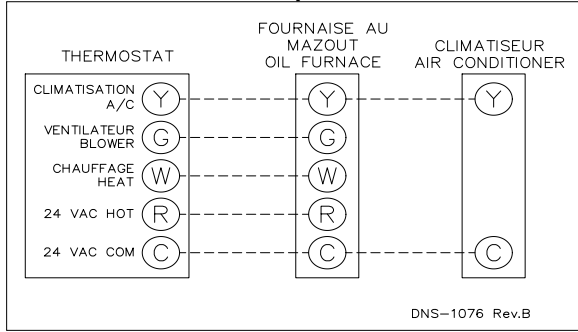

Figure 3: Thermostat wiring, heating and air conditioning with ECM variable speed motor

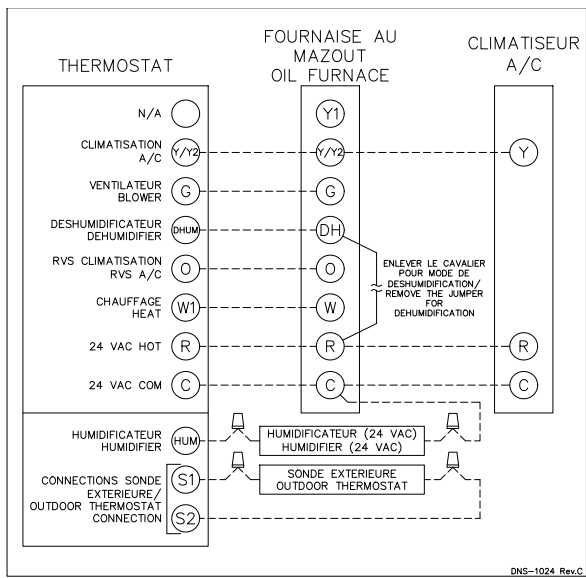
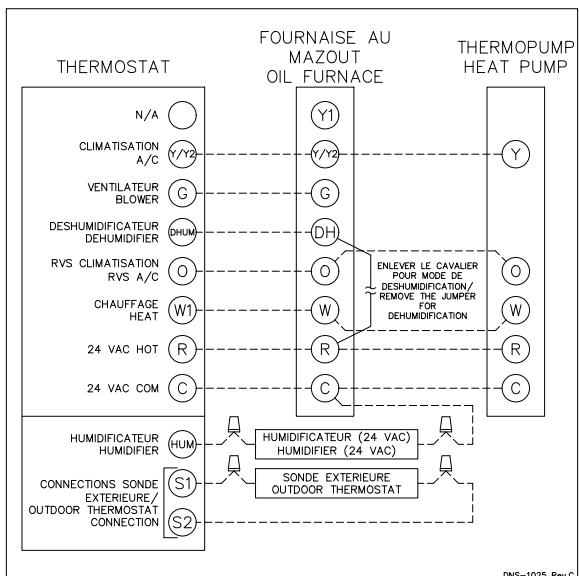

Figure 4: Thermostat wiring, heating and air conditioning/heat pump with ECM variable speed motor



Note: On units with 2 stage cooling or heat pump, terminal Y1 must be used. When Y1 on the electronic control receives a 24 VAC signal, the air flow is reduced by 20%. Do not use terminal Y1 with a single stage cooling or heat pump.

2.4 INSTALLATION OF THE BURNER

Also refer to the burner manufacturer's instructions.

1. Position the mounting gasket between the mounting flange and the burner mounting plate. Align the holes in the burner mounting plate with the studs on the mounting flange and bolt securely in place.
2. Remove the burner drawer assembly or the air tube assembly;
3. Install the nozzle (refer to Technical Specifications, Table 7);
4. Check the electrode settings;
5. Make the electrical connections;
6. Complete oil line connections.

2.4.1 Nozzles

The burner comes equipped with an appropriate nozzle. However, if another size or a replacement nozzle is required, use the manufacturer's recommended spray angle and type as shown in Table 7 and based on a pump pressure of 100 psi.

Always select nozzle sizes by working back from the desired flow rate at operating pressure and not the nozzle marking.

2.4.2 Air and Turbulator Settings

Before starting the burner for the first time, adjust the air and turbulator settings to those listed in this manual (Table 7). Once the burner becomes operational, final adjustments will be required. Refer to section 3 of this manual.

2.4.3 Post purge delay adjustment

The post purge delay on the oil-fired burners is factory set to zero second. This delay is applicable for all installations with chimney venting. For heating units installed with side wall venting and burners equipped with this feature, the post purge delay must be set to 15 seconds. No delay is required for Riello burners. Refer to the burner control instruction manual and markings for proper adjustment of the post purge delay.

2.5 VENTING

WARNING

Poisonous carbon monoxide gas, fire and explosion hazard.

Read and follow all instructions in this section. Failure to properly vent this furnace can result in death, bodily injury and/or property damage.

To ensure the safe and proper functioning of an oil furnace, it must always be connected to a flue with sufficient draft or to an approved side-wall venting system. In addition, it is strongly recommended to perform a complete inspection of all the existing venting systems.



WARNING

Poisonous carbon monoxide gas hazard.

Never install a hand operated damper in the vent pipe. However, any Underwriters Laboratories listed, electrically operated automatic type vent damper may be installed if desired. Be sure to follow the instructions provided with vent damper. Also, read and follow all instructions in this section of the manual.

Failure to properly vent this furnace or other appliances can result in death, bodily injury and/or property damage.

2.5.1 Masonry chimney

This furnace can be vented into an existing masonry chimney. However, the unit must not be vented into a chimney into which a solid fuel burning furnace is already being vented.

Before venting this furnace into a chimney, its condition must be checked and repairs made, if necessary. Also, the chimney lining and dimensions must conform to local and national codes.

2.5.2 Factory Built Chimneys

Oil fired furnaces are approved for use with "L" type vents. The unit may also be used with an approved chimney of proper dimensions and temperature ratings as specified in the installation code. Refer to chimney manufacturer's instructions for proper installation.

2.5.3 Draft Regulator

It is recommended that a draft regulator be installed in cases where the draft is either high or variable due to external conditions. Follow the instructions provided with the regulator.

2.5.4 Side-wall Venting

The heating unit is approved for side-wall venting. This system is comprised of a model VTK-54 / VTK-098 / KLAVT0101DET side-wall venter and a 4" insulated vent pipe, model IFV-410 / IFV098-10 / KLAHV0101DET, IFV-420 / IFV098-20 / KLAHV0201DET. Refer to the installation instructions provided with the venting system.

2.6 BLOCKED VENT SHUT-OFF DEVICE (BVSO) FOR CHIMNEY VENTING



CAUTION

It is imperative that this device be installed by a qualified service technician.

A positive pressure venting system (Sealed Combustion System or Direct Vent) **MUST NOT** use the BVSO. Follow the instructions supplied with the venting system.

This device is designed to detect the insufficient evacuation of combustion gases in the event of a vent blockage. In such a case the thermal switch will shut down the oil burner. The device will then need to be re-armed MANUALLY.

Refer to the detailed instructions and wiring diagrams supplied with the BVSO for the installation and wiring procedures. The length of wires supplied with the unit is such that the safety device must be installed between the flue outlet of the appliance and the draft regulator, as indicated in the instructions.

It is also essential that the BVSO be maintained annually. For more details refer to the instructions supplied with the device itself, as well as Section 3 of this Manual.

2.6.1 BVSO Performance Test

The purpose of the following test is to check that the electrical outlet on the furnace, designated to the BVSO, is functional.

1. Start up the burner;
2. Remove the three-pole plug from the BVSO outlet on the furnace;
3. The burner must shut-off immediately, while the blower continues to run to the end of the cool-down cycle.

If the test is not in line with the above, call a QUALIFIED SERVICE TECHNICIAN.

2.7 COMBUSTION AIR SUPPLY AND VENTILATION



WARNING

Poisonous carbon monoxide gas hazard.

Comply with NFPA 31 (U.S.) and CSA B139 (Canada) standards for the installation of Oil Burning Equipment and applicable provisions of local building codes to provide combustion and ventilation air.

Failure to provide adequate combustion and ventilation air can result in death, bodily injury and/or property damage.

Oil furnaces must have an adequate supply of combustion air. It is common practice to assume that older homes have sufficient infiltration to accommodate the combustion air requirement for the furnace. However, home improvements such as new windows, doors, and weather stripping have drastically reduced the volume of air infiltration into the home.

Refer to oil furnace installation codes relative to combustion and ventilation air requirements. Consult Section 2.1 in this manual, specifically for units installed in an enclosed space.

Home air exhausters are common. Bathroom and kitchen fans, power vented clothes dryers and water heaters all tend to create a negative pressure condition in the home. Should this occur the chimney becomes less and less effective and can easily downdraft. In certain cases, mechanically supplied air, by way of a blower, interlocked with the unit, is necessary. It is the installer's responsibility to check that.

2.7.1 Contaminated Combustion Air

Installations in certain areas or types of structures will increase the exposure to chemicals or halogens that may harm the furnace. These conditions will require that only outside air be used for combustion.

The following areas or types of structures may contain or be exposed to certain substances, potentially requiring outside air for combustion:

- a. Commercial buildings;
- b. Buildings with indoor pools;
- c. Furnaces installed near chemical storage areas.

Exposure to the following substances:

- a. Permanent wave chemicals for hair;
- b. Chlorinated waxes and cleaners;
- c. Chlorine based swimming pool chemicals;
- d. Water softening chemicals;
- e. De-icing salts or chemicals;
- f. Carbon tetrachloride;
- g. Halogen type refrigerants;
- h. Cleaning solvents (such as perchloroethylene);
- i. Printing inks, paint removers, varnishes, etc. ;
- j. Hydrochloric acid;
- k. Solvent based glue;
- l. Antistatic fabric softeners for clothes dryers;
- m. Acid based masonry cleaning materials.

2.7.2 Burner with Outdoor Combustion Air Kit

Certain burners are designed to function with combustion air taken directly from the outside. Follow the instructions provided with the burner, the fresh-air supply kit or the side-wall venting kit.

2.8 OIL TANK

 **WARNING**

Fire and explosion hazard.
Use only approved heating type oil in this furnace. DO NOT USE waste oil, used motor oil, gasoline or kerosene.
Use of these will result in death, bodily injury and/or property damage.

 **CAUTION**

When a 0.75 USGPH or smaller nozzle is used, a 10 micron or finer filter, must be installed on the oil supply line to the furnace inside the building where the unit is located.
This is a requirement in order for the heat exchanger warranty to remain in force.

Check your local codes for the installation of the oil tank and accessories.

At the beginning of each heating season or once a year, check the complete oil distribution system for leaks.

Ensure that the tank is full of clean oil. Use No.1 or No.2 Heating Oil (ASTM D396 U.S.) or in Canada, use No.1 or No.2 Furnace Oil.

A manual shut-off valve and an oil filter shall be installed in sequence from tank to burner. Be sure that the oil line is clean before connecting to the burner. The oil line should be protected to eliminate any possible damage. Installations where the oil tank is below the burner level must employ a two-pipe fuel supply system with an appropriate fuel pump. A rise of 2.4 m (8') and more requires a two stage pump and a rise greater than 4.9 m (16') an auxiliary pump. Follow the pump instructions to determine the size of pipe needed in relation to the rise or to the horizontal distance.

2.9 DUCTING

 **WARNING**

Poisonous carbon monoxide gas hazard.
DO NOT draw return air from inside a closet or utility room. Return air MUST be sealed to the furnace casing.
Failure to properly seal ducts can result in death, bodily injury and/or property damage.

The ducting must be designed and installed according to approved methods, local and national codes as well as good trade practices.

When ducting supplies air to a space other than where the furnace is located, the return air must be sealed and also be directed to the space other than where the furnace is located.

2.9.1 Air filter

A properly sized air filter must be installed on the return air side of the unit. Refer to the Technical Specifications, (Table 7), for the correct dimensions. Also refer to Section 2.3 and the instructions supplied with the filter.

2.10 SUPPLY AIR ADJUSTMENTS (4 SPEED MOTOR)

On units equipped with 4-speed blower motors, the supply air must be adjusted based on heating/air conditioning output and the static pressure of the duct system. For the desired air flow refer to the following tables as well as the air flow tables based on static pressure in the Table 7 of this manual.

Table 1: Supply air adjustments, heating mode, 4 speed motor

HEATING CAPACITY (USGPH)	STATIC PRESSURE (W.C.)	RECOMMENDED BLOWER SPEED
0.68	0.25"	MED-LOW
0.68	0.50"	MED-LOW
0.80	0.25"	MED-HIGH
0.80	0.50"	MED-HIGH

Table 2: Supply air adjustments, A/C mode, 4 speed motor

A/C CAPACITY (TONS)	RECOMMENDED BLOWER SPEED
2.5	MED-LOW
3.0	MED-HIGH
4.0	HIGH

To effect the adjustment, the RED (for heating) and BLUE (for cooling and heat pump) wires can be changed on the motor. Also, refer to the position of the wires on the electronic board of the unit and consult the wiring diagrams. If the heating and air conditioning speeds are the same, the RED wire must be moved to "UNUSED LEADS" on the electronic board and the jumper provided with the BLUE wire must be used between the "HEAT" and "COOL" terminals.

The blower start/stop delays can be adjusted by positioning the DIP switches on the electronic board as shown in the following figures. However, the recommended adjustments are 60 seconds blower ON delay and 2 minutes blower OFF delay.

Figure 5: Supply air adjustments, start/stop delays, board #1158

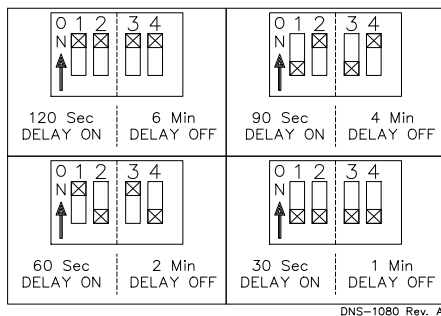

DNS-1080 Rev. A

2.11 SUPPLY AIR ADJUSTMENTS (ECM VARIABLE SPEED MOTORS)

On units equipped with ECM variable speed blower motors, the air supply must be adjusted based on heating/air conditioning output. The start/stop delays of the blower must also be adjusted by positioning the DIP switches on the electronic board. Refer to the following tables, the airflow CFM table 8 and the wiring diagram (Figure 8) in this manual for the proper settings:

Table 3: Supply air adjustments, heating mode, variable speed motor (ECM)

SW1 – HEAT DIP Switch Positions			Input USGPH
1	2	POSITION	
OFF	OFF	A	0.68
ON	OFF	B	0.80
OFF	ON	C*	0.68
ON	ON	D*	0.80

* Alternate adjustment for a higher air temperature rise.

Table 4: Supply air adjustments, air conditioning mode, variable speed motor (ECM)

SW2 – COOL DIP Switch Positions			Output Tons
1	2	POSITION	
OFF	OFF	A	4.0
ON	OFF	B	3.5
OFF	ON	C	3.0
ON	ON	D	2.5

Table 5: Supply air adjustments, all modes, variable speed motor (ECM)

SW3 – ADJ (Adjustment) DIP Switch Positions			CFM HTG. % increase or decrease	CFM A/C % increase or decrease
1	2	POSITION		
OFF	OFF	A	0%	0%
ON	OFF	B	+10%	+10%
OFF	ON	C	-10%	-10%
ON	ON	D	N/A	0%

Table 6: Delay adjustments, heating mode, variable speed motor (ECM)

SW4 – Delay DIP Switch Positions			Input USGPH
1	2	POSITION	
OFF	OFF	A	0.68
ON	OFF	B	0.80
OFF	ON	C*	ALL
ON	ON	D*	ALL

* Alternate adjustments for both input rate (refer to air flow table).

2.12 INSTALLATION OF ACCESSORIES



WARNING

Electrical shock hazard.

Turn OFF electrical power at the fuse box or service panel before making any electrical connections and ensure a proper ground connection is made before connecting line voltage.

Failure to do so can result in death or bodily injury.

2.12.1 Humidifier (HUM)

The 120 VAC HUM terminal on the electronic board of the blower supplies 120 VAC electric power when the burner is in operation.

A 24 VAC signal can also be supplied from the W and C terminals on the blower electronic board to activate a switching relay.

Also refer to the instructions supplied with the accessory.

2.12.2 Electronic Air Cleaner (EAC)

The EAC terminal on the electronic board supplies 120 VAC when the blower is operating in the heating or air conditioning mode. This signal can be used to activate an electronic air cleaner that is not equipped with an air flow switch. If the cleaner is equipped with an air flow switch, the S terminal on the electronic board or one of the 120 VAC terminals on the ECM can be used to provide a constant supply of 120 VAC.

Also refer to the instructions supplied with the accessory.

2.12.3 Air Conditioner (or Heat Pump)

An air conditioning coil may be installed on the supply air side ONLY.



WARNING

Poisonous carbon monoxide gas hazard.

Install the evaporator coil on the supply side of the furnace ducting ONLY.

An evaporator coil installed on the return air side of the ducting can cause condensation to form inside the heat exchanger, resulting in heat exchanger failure. This in turn, can result in death, bodily injury and/or property damage.

A clearance of 15 cm (6") is required between the bottom of the coil drain pan and the top of the heat exchanger. If a heat pump is installed, a "dual-energy" thermostat, or other control is recommended, in order to prevent the simultaneous operation of the furnace and the heat pump. It also prevents a direct transition from heating by way of the heat pump to heating with oil. Refer to the thermostat instructions or those of another control used for the proper wiring.

3 OPERATION

3.1 START-UP

Before starting up the unit, be sure to check that the following items are in compliance:

1. The electrical installation, the oil supply system, the venting system, combustion air supply and ventilation;
2. The blower access door is in place and the blower rail locking screws are well tightened;
3. The Blocked Vent Shut-Off (BVSO) is installed according to instructions (for chimney venting);
4. The oil supply valve is open;
5. The burner "Reset" button is well pushed in or re-armed;
6. **The preliminary air adjustments on the burner** comply with the technical specifications in this manual;
7. The blower speed adjustments for heating and air conditioning are appropriate and according to the specifications in this manual;
8. The blower start/stop delays are satisfactory;
9. The thermostat of the room is in the heating mode and is set higher than the ambient temperature.

To start the unit, turn the main electrical switch on.

3.2 OPERATING SEQUENCE OIL HEATING MODE

1. The W-R contact closes;
2. The burner motor starts up to pre-purge the combustion chamber for a period of 10 to 15 seconds. During that time a spark is established on the electrodes;
3. The solenoid valve opens and a flame is established. Shortly after, the electrodes cease to spark;
4. Then the blower runs up to full speed. The delay depends on the adjustments that were made on the electronic board, which controls the blower motor. Refer to Sections 2.11 and 2.12, above, as well as the CFM Tables 8 and 9 for more details.
5. When the call for heat is satisfied, the solenoid valve closes, the flame goes out and the burner motor stops (after post purge delay, if applicable).
6. The blower stops shortly after the burner. The delay depends on the adjustments that were made on the electronic board that controls the blower. Refer to Sections 2.11 and 2.12, as well as the CFM Tables 8 and 9 for more details.

Note: A detailed operating sequence of the oil burner is outlined in the instructions provided with the burner.

3.3 CHECKS AND ADJUSTMENTS

3.3.1 Purging the oil line

Open the bleed port screw and start the burner. Allow the oil to drain into a container for at least 10 seconds. The oil should flow absolutely free of white streaks or air bubbles to indicate that no air is being drawn into the suction side of the oil piping and pump. Slowly close and tighten the bleed screw. Once closed, the flame will light up.

3.3.2 Pressure adjustment

The oil pressure must be adjusted according to the Technical Specifications of this manual. An adjustment screw and a connection for a pressure gauge are located on the oil pump for that purpose. Also refer to the burner instruction manual.

3.3.3 Combustion Check

IMPORTANT

The heat exchanger metal surfaces may have oil and the baffle insulation also contains binders. These products will burn or evaporate when the unit operates for the first time. Because of that, the smoke reading may be skewed during the first minutes of operation. Therefore, the unit must operate during at least 60 minutes before taking any readings to adjust the combustion quality. Let the unit cool down before making any adjustments.

IMPORTANT

The combustion check verification **MUST** be performed after the nozzle replacement or the burner cleaning. After these manipulations, the combustion parameters are necessarily modified. Refer also to the burner instruction manual.

1. Pierce a test hole in the flue pipe, approximately 18 inches from the furnace breech. Insert the smoke test probe into the hole. For installation using a sidewall venting, use the orifice provided on the breech plate;
2. From a cold start, let the unit operate for about 5 minutes;
3. Set the burner air setting until you have between 0 and 1 on the Bacharach Scale (or a "trace");
4. Take a CO₂ sample at the same test location where the "trace" of smoke reading was taken and make note of it. Example: 13.8% of CO₂ or 2.5% of O₂;
5. Adjust the burner air setting to obtain a CO₂ reading 1.5% lower (or a O₂ reading 2.0% higher) than the reading associated with the "trace" of smoke. Example: 12.3% of CO₂ or 4.5% of O₂;
6. This method of adjusting the burner will result in clean combustion (Bacharach smoke scale between 0 and a trace) and ensure the proper functioning of the system. The optimum CO₂ level is around 12% to 13% (or 3.5% to 5.0% of O₂).

3.3.4 Draft Regulator adjustment

On chimney installations only, a barometric draft regulator (supplied with the furnace) must be installed, in order to ensure proper draft through the furnace. The barometric damper must be mounted with the hinge pins in a horizontal position and the face of the damper vertical for proper functioning (see instructions included with the damper.) After the furnace has been firing for at least five minutes, the draft regulator should be set to between -0.025" and -0.060" W.C.

3.3.5 Overfire pressure test

The overfire draft that is taken through the observation port, located above the burner, is a measurement necessary to determine if there is a blockage in the heat exchanger or the flue pipe. Refer to the Technical Specifications in this manual for overfire pressure values. A high pressure condition may be caused by excessive combustion air, due to the air band being too wide open, or a lack of flue draft (chimney effect) or some other blockage, such as soot in the secondary section of the heat exchanger or the use of an oversize nozzle input or high pressure pump.

3.3.6 Vent Temperature Test

1. After having adjusted the burner combustion, insert a thermometer into the test hole in the breech pipe;
2. The total vent temperature should be between 204 and 302°C (400 and 575°F). If not, check for improper air temperature rise, pump pressure, nozzle size or a badly sooted heat exchanger. Also refer to section 2.5 for proper flue pipe sizing.



CAUTION

Low flue gas temperature increases the risk of condensation. Adjust the total flue gas temperature at or higher than 204°C (400°F) in order for the heat exchanger warranty to remain in force.

3.3.7 Supply Air Temperature Rise Test

1. Operate the burner for at least 10 minutes;
2. Measure the air temperature in the return air plenum;
3. Measuring the air temperature in the largest trunk coming off the supply air plenum, just outside the range of radiant heat from the heat exchanger. 0.3 m (12") from the plenum of the main take-off is usually sufficient;
4. The temperature rise is calculated by subtracting the return air temperature from the supply air temperature;
5. If the temperature rise is lower or exceeds the temperature specified in Table 7, change to the next lower or higher blower speed tap, until the temperature rise falls to the target. If the excessive temperature rise cannot be increased or reduced by changing fan speed, investigate for ductwork obstructions, dirty or improper air filter, improper firing caused by improper pump pressure or nozzle sizing.

3.3.8 Limit Control Check

After operating the furnace for at least 15 minutes, restrict the return air supply by blocking the filters or the return air register and allow the furnace to shut off on High Limit. The burner will shut off but the blower will continue to run.

Remove the obstruction and the burner should restart after a few minutes. The time required for the restart also depends on the adjustment of the blower "OFF" delay.

3.3.9 Restart after Burner Failure

1. Set the thermostat lower than room temperature;
2. Press the reset button on the burner primary control (relay);
3. Set the thermostat higher than room temperature;
4. If the burner motor does not start or ignition fails, turn off the disconnect switch and CALL A QUALIFIED SERVICE TECHNICIAN.



CAUTION

Do not attempt to start the burner when excess oil has accumulated when the furnace is full of vapour or when the combustion chamber is hot.

4 MAINTENANCE



WARNING

Electrical shock hazard.

Turn OFF power and fuel to the furnace before any disassembly or servicing.

Failure to do so can result in death, bodily injury and/or property damage.

Preventive maintenance is the best way to avoid unnecessary expense and inconvenience. Have your heating system and burner inspected by a qualified service technician at regular intervals.

To maintain the reliability and optimal performance of the furnace, have a complete combustion check done after the annual maintenance call. Do not attempt to repair the furnace or its controls. Call a qualified service technician.

Before calling for repair service check the following points:

1. Check the oil tank gauge and make sure that the valve is open;
2. Check fuses and the circuit breaker;
3. Check if the main disconnect switch is ON ;
4. Set the thermostat above room temperature;
5. If ignition does not occur, turn off the disconnect switch and call a qualified service technician.

When ordering replacement parts, please specify the complete furnace model number and serial number.

4.1 CLEANING THE HEAT EXCHANGER

It is not generally necessary to clean the heat exchanger or flue pipe every year, but it is advisable to have the oil burner service technician check the unit before each heating season to determine whether the cleaning or replacement of parts is necessary.

If a cleaning is necessary, the following steps should be performed:

1. **Turn OFF all utilities upstream from the furnace;**
2. Disconnect the flue pipe;
3. Remove the flue collar panel located at the rear of the furnace;
4. Remove the clean-out door located at the front of the furnace;
5. Remove the heat exchanger baffles;
6. Disconnect the oil line and remove the oil burner;
7. Clean the secondary tubes and the primary cylinder with a stiff brush and a vacuum cleaner;
8. Before re-assembling the unit, the heat exchanger and combustion chamber should be inspected to determine if replacement is required;
9. After the cleaning replace the heat exchanger baffles, flue collar plate and oil burner;
10. Readjust the burner for proper operation.

4.2 CLEANING THE BLOCKED VENT SHUT-OFF DEVICE (BVSO)

For continuous safe operation, the Blocked Vent Shut-off device (BVSO) must be inspected and maintained annually by a qualified service technician.

1. **Disconnect power to the appliance;**
2. Remove the two screws holding on the BVSO assembly cover;
3. Remove the cover;
4. Remove the two screws holding the control box to the heat transfer tube assembly. Sliding the control box in the appropriate direction will unlock it from the heat transfer tube assembly;
5. Carefully remove any build-up from the thermal switch surface;



CAUTION

Do not dent or scratch the surface of the thermal switch. If the thermal switch is damaged it MUST be replaced.

6. Clean and remove any build-up or obstruction inside the heat transfer tube;
7. Re-mount, lock and fasten the control box with the 2 screws removed in step 4;
8. Re-attach the assembly cover with the screws removed in step 2;
9. Re-establish power to the unit.

4.3 CHANGING OF THE BURNER HEAD

Once annually, remove the retention head and electrodes from the drawer assembly and remove all foreign matter, if necessary. Also clean the extremity of the burner tube, if necessary.

4.4 CHANGING THE NOZZLE

Change the nozzle once a year with the one specified in Table 8.

4.5 CHANGING THE OIL FILTER

Tank Filter

The tank filter should be changed as required. Follow the manufacturer's instructions.

Secondary Filter

The 10 micron, or finer, filter cartridge should be changed annually. Follow the manufacturer's instructions.

4.6 CHANGING THE AIR FILTER

Dirty filters have an impact on the efficiency of the furnace and increase fuel consumption.

Air filters should be changed at least once a year. Very dusty conditions, the presence of animal hair and the like will require more frequent changing or cleaning.

5 FURNACE INFORMATION

Model: _____ Serial number: _____

Furnace installation date: _____

Service telephone # Day: _____ Night: _____

Dealer name and address: _____

START-UP RESULTS

Nozzle: _____ Pressure: _____ lb/po²

Burner adjustments: Primary air _____

Fine air _____

Drawer Assembly _____

CO₂ : _____ % Smoke scale: _____ (Bacharach)

Gross stack temperature: _____ °F

Ambient temperature: _____ °F

Chimney draft : _____ " W.C.

Overfire draft : _____ " W.C.

Test performed by: _____

Table 7: Technical specifications

112 LOWBOY SERIES	UNITS WITH 1/2 HP 4-SPD MOTOR		UNITS WITH 3/4 HP ECM MOTOR	
RATING AND PERFORMANCE				
Firing rate (USGPH)*	0.68		0.80	
Input (BTU/h)*	95 200		112 000	
Heating temperature rise (Degr. F)*	55° - 75° Degr. F		60° - 72° Degr. F	
Flue draft with chimney (inch of w.c.)	-0.06 to -0.025		-0.06 to -0.025	
Overfire pressure with chimney (inch of w.c.)	-0.035 to +0.025		-0.035 to +0.025	
Flue pressure with direct vent (inch of w.c. - no wind)	+0.03 à +0.15		+0.03 à +0.15	
Overfire pressure with direct vent (inch of w.c. - no wind)	+0.05 à +0.17		+0.05 à +0.17	
BECKETT BURNER; MODEL AFG (Chimney) / Insertion	AFG70MQSS / 1 3/4"		AFG70MQSS / 1 3/4"	
AHRI Model #	OLR095-BF	OLR112-BF	OLV095-BF	OLV112-BF
Maximum Heating capacity, (BTU/h)*	81 000	94 000	81 000	94 000
Head type	2 - Slot L2 Head		2 - Slot L2 Head	
Nozzle (Delavan)**	0.60 - 60W	0.65 - 60B	0.60 - 60W	0.65 - 60B
Pump pressure (PSIG)*	140	150	140	150
Head/Air setting	8/0	7/0 (Note 1)	8/0	7/0 (Note 1)
AFUE % (From CSA B212 standard and Canadian regulation)***	87.2%	86.4%	87,2% ‡	86,4% ‡
AFUE % (From ASHRAE 103 standard and US regulation)***	87.1%	86.3%	87,1% ‡	86,3% ‡
BECKETT BURNER; MODEL NX (Chimney or DV) / Insertion	NX56LQ / 1 3/4"		NX56LQ / 1 3/4"	
AHRI Model #	OLR095-BNX	OLR112-BNX	OLV095-BNX	OLV112-BNX
Maximum Heating capacity, (BTU/h)*	80 000	93 000	80 000	93 000
Head type	6 - Slot LQ head		6 - Slot LQ head	
Nozzle (Delavan)**	0.60 - 60W	0.65 - 60W	0.60 - 60W	0.65 - 60W
Pump pressure (PSIG)*	140	150	140	150
Head/Air setting	3.0	3.5	3.0	3.5
AFUE % (From CSA B212 standard and Canadian regulation)***	88.1%	87.0%	88,1% ‡	87,0% ‡
AFUE % (From ASHRAE 103 standard and US regulation)***	87.0%	85.9%	87,0% ‡	85,9% ‡
RIELLO BURNER; MODEL 40-F3 (Chimney) / Insertion	F3 WITH AIR INLET DAMPER / 2 3/4"		F3 WITH AIR INLET DAMPER / 2 3/4"	
AHRI Model #	OLR095-RF	OLR112-RF	OLV095-RF	OLV112-RF
Maximum Heating capacity, (BTU/h)*	80 000	94 000	80 000	94 000
Nozzle (Delavan)**	0.60 - 70A	0.70 - 70A	0.60 - 70A	0.70 - 70A
Pump pressure (PSIG)*	130	130	130	130
Combustion air adjustment (turbulator/damper)	1 / 2.6	2 / 3.1	1 / 2.6	2 / 3.1
AFUE % (From CSA B212 standard and Canadian regulation)***	87.6%	87.4%	87,6% ‡	87,4% ‡
AFUE % (From ASHRAE 103 standard and US regulation)***	86.6%	86.1%	86,6% ‡	86,1% ‡
RIELLO BURNER; MODEL 40-BF5 (Direct vent DV) / Insertion	BF5 / 2 3/4"		BF5 / 2 3/4"	
AHRI Model #	OLR095-RBF	OLR112-RBF	OLV095-RBF	OLV112-RBF
Maximum Heating capacity, (BTU/h)*	81 000	94 000	81 000	94 000
Nozzle (Delavan)**	0.60 - 70A	0.70 - 70A	0.60 - 70A	0.70 - 70A
Pump pressure (PSIG)*	130	130	130	130
Combustion air adjustment (turbulator/damper)	0 / 2.75	0 / 3.25	0 / 2.75	0 / 3.25
AFUE % (From CSA B212 standard and Canadian regulation)***	87.4%	86.5%	87,4% ‡	86,5% ‡
AFUE % (From ASHRAE 103 standard and US regulation)***	87.2%	86.5%	87,2% ‡	86,5% ‡
ELECTRICAL SYSTEM				
Volts - Hertz - Phase	115 - 60 - 1		115 - 60 - 1	
Rated current (Amps)	12.6		12.2	
Minimum ampacity for wire sizing (Amps)	15.2		14.7	
Max. fuse size (Amps)	20		15	
Control transformer (VA)	40		40	
External control power available Heating (VA)	40		40	
Cooling (VA)	30		30	
BLOWER DATA				
Heating blower speed at 0.25" W.C. SP	MED-LOW	MED-HIGH	See the ECM air flow table	
Heating blower speed at 0.50" W.C. SP	MED-LOW	MED-HIGH		
Motor (HP) / number of speeds	1/2 HP / 4 speeds		3/4 HP / ECM (with power choke)	
Blower size (diam. x width)	12" x 9" (tight housing)		12" x 9" (tight housing)	
GENERAL INFORMATION				
Overall dimensions (width x depth x height)	21" x 48" x 33"		21" x 48" x 33"	
Supply air opening (width x depth)	19 3/4" x 19 3/4"		19 3/4" x 19 3/4"	
Return air opening (width x depth)	19 3/4" x 19 3/4"		19 3/4" x 19 3/4"	
Filter size and quantity	20" x 20" x 1" (or 2") 16" x 20" x 1" (quantity = 2)		20" x 20" x 1" (or 2") 16" x 20" x 1" (quantity = 2)	
Shipping weight Lbs/Kg	195 Lbs / 89 Kg		195 Lbs / 89 Kg	
Air conditioning, maximum output (tons) at 0.5" W.C. SP	4.0		4.0	

Note 1 : Without low firing baffle #5880.

*** INPUT & OUTPUT ADJUSTMENT**

- Pump pressure can be adjusted to maintain proper firing rate.
- Pump pressure can be adjusted to maintain proper firing rate.
- Adjust the total flue gas temperature between 400°F and 575°F (330°F and 505°F net approximately)

**** Default installed Nozzle in bold characters.**

***** AFUE values established after minimum 20 hours of operation.**

≠



Table 8: Airflow data, models with 3/4 HP variable speed motors (ECM)

OIL HEATING MODE				
24 VAC input (R) on W only				
SW1- HEAT DIP switch position	HEAT INPUT (USGPH)	CFM with SW3-ADJ DIP switch position A	CFM with SW3-ADJ DIP switch position B	CFM with SW3-ADJ DIP switch position C
A (1=OFF, 2=OFF)	0,68	1160	1275	1045
B (1=ON, 2=OFF)	0,80	1340	1475	1205
C (1=OFF, 2=ON)*	0,68	1000	1100	900
D (1=ON, 2=ON)*	0,80	1160	1275	1045

CONTINUOUS FAN				
24 VAC input (R) on G only				
SW2- COOL DIP switch position	A/C size (TON)	CFM with SW3-ADJ DIP switch position A	CFM with SW3-ADJ DIP switch position B	CFM with SW3-ADJ DIP switch position C
A (1=OFF, 2=OFF)	4,0	1200	1380	1020
B (1=ON, 2=OFF)	3,5	1050	1210	875
C (1=OFF, 2=ON)	3,0	900	1035	765
D (1=ON, 2=ON)	2,5	750	865	640

COOLING OR HEAT PUMP HEATING MODE				
24 VAC input (R) to G, Y/Y2 and O (for cooling)				
SW2- COOL DIP switch position	A/C size (TON)	CFM with SW3-ADJ DIP switch position A	CFM with SW3-ADJ DIP switch position B	CFM with SW3-ADJ DIP switch position C
A (1=OFF, 2=OFF)	4,0	1600	1750	1440
B (1=ON, 2=OFF)	3,5	1400	1540	1260
C (1=OFF, 2=ON)	3,0	1200	1320	1080
D (1=ON, 2=ON)	2,5	1000	1100	900

In Cooling - Dehumidification mode, with no 24 VAC input to DH, the CFMs are reduced by 15%.

The CFMs shown are reduced by 20% if there is 24 VAC input to Y1 (first stage cooling mode)

DELAY PROFILE FOR OIL HEATING MODE				
SW4- DEALY DIP switch position	HEAT INPUT (USGPH)	PreRun On-Delay CFM Level - Time	ShortRun On-Delay CFM Level - Time	Off-Delay CFM Level - Time
A (1=OFF, 2=OFF)	0,68	13% - 45 sec.	19% - 60 sec	38% - 3 min.
B (1=ON, 2=OFF)	0,80	13% - 45 sec.	19% - 30 sec	38% - 3 min.
C (1=OFF, 2=ON)	All	13% - 45 sec.	100% - 0 sec	100% - 2 min.
D (1=ON, 2=ON)	All	13% - 90 sec.	100% - 0 sec	100% - 2 min.

PreRun and ShortRun are the periods of time when the the blower starts at very low CFM to minimize the distribution of cool air in the system and then runs up to normal speed.

Off Delay is the time required to cool down the heat exchanger with low CFMs, to minimize cool draft in the air distribution system.

DELAY PROFILE FOR COOLING OR HEAT PUMP HEATING MODE				
No adjustment required	A/C size	PreRun On-Delay CFM Level - Time	ShortRun On-Delay CFM Level - Time	Off-Delay CFM Level - Time
-	All	NO DELAY	NO DELAY	100% - 90 sec

* Alternate adjustment in oil-fired heating mode for higher temperature rise

Table 9: Airflow data, models with 1/2 HP 4 speed motors

BLOWER SPEED	EXTERNAL STATIC PRESSURE WITH AIR FILTER					
	0.2" (W.C.)	0.3" (W.C.)	0.4" (W.C.)	0.5" (W.C.)	0.6" (W.C.)	0.7" (W.C.)
HIGH	1680	1640	1600	1590	1540	1460
MED-HIGH	1210	1190	1180	1160	1130	1110
MED-LOW	1110	1070	1040	1010	970	930
LOW	960	940	920	890	860	830

Table 10: Minimum clearances from combustible material

LOCATION	APPLICATION	CLEARANCES (combustible materials)	RECOMMENDED ACCESS FOR SERVICE
SIDES	FURNACE	2.54 cm (1")	0.6 m (24")
	SUPPLY PLENUM WITHIN 6 FEET OF FURNACE	2.54 cm (1")	
BACK	ACCESS PANEL TO BLOWER	10.16 cm (4")	0.6 m (24")
TOP	FURNACE OR PLENUM	5.08 cm (2")	
	HORIZONTAL WARM AIR DUCT WITHIN 6 FEET OF FURNACE	5.08 cm (2")	
BOTTOM	FURNACE (COMBUSTIBLE FLOOR)	0 cm (0")	
FLUE PIPE	AROUND FLUE PIPE	22.86 cm (9")	
FRONT	FURNACE	20.32 cm (8")	0.6 m (24")

Figure 6: Furnace dimensions

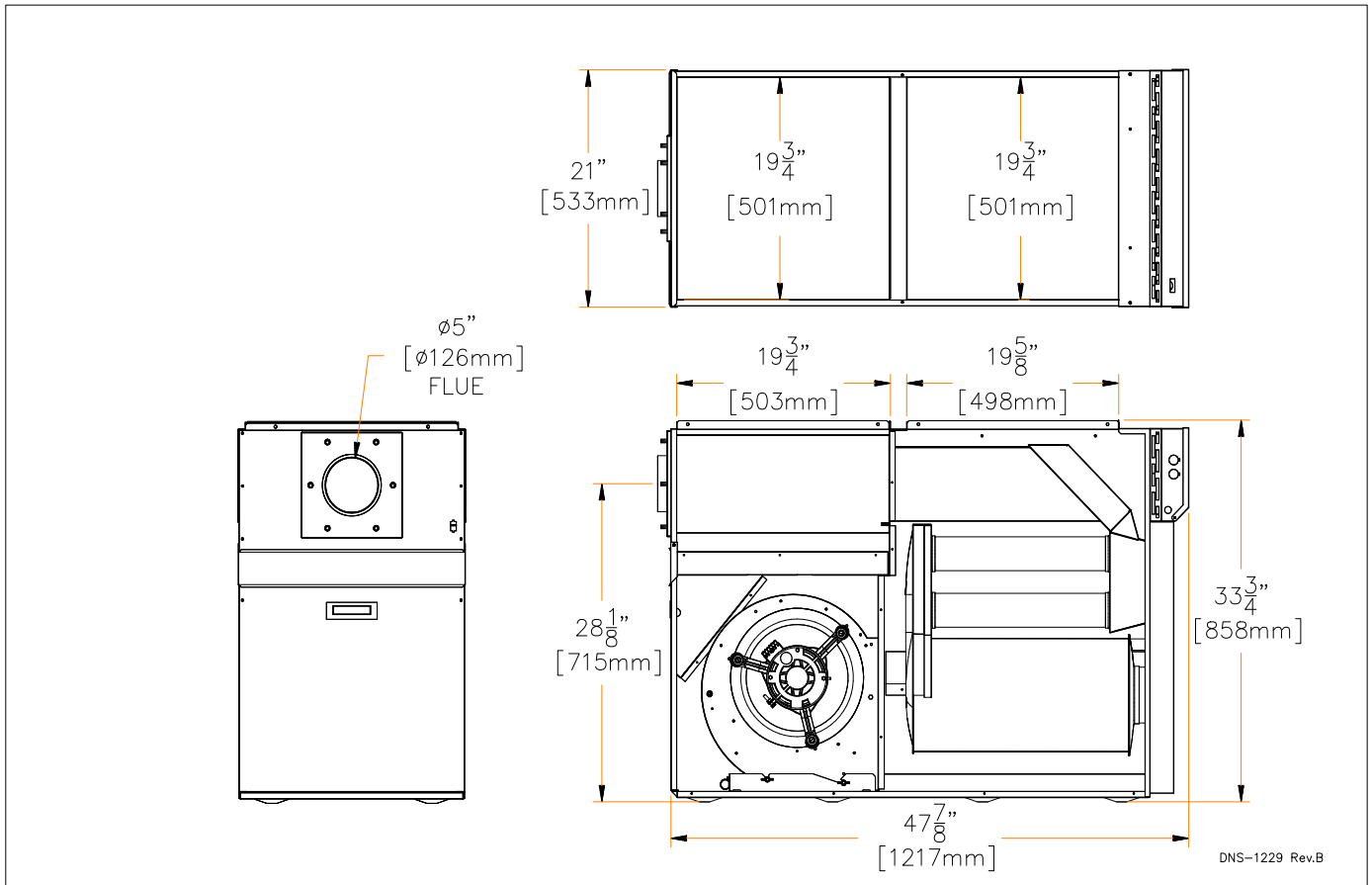
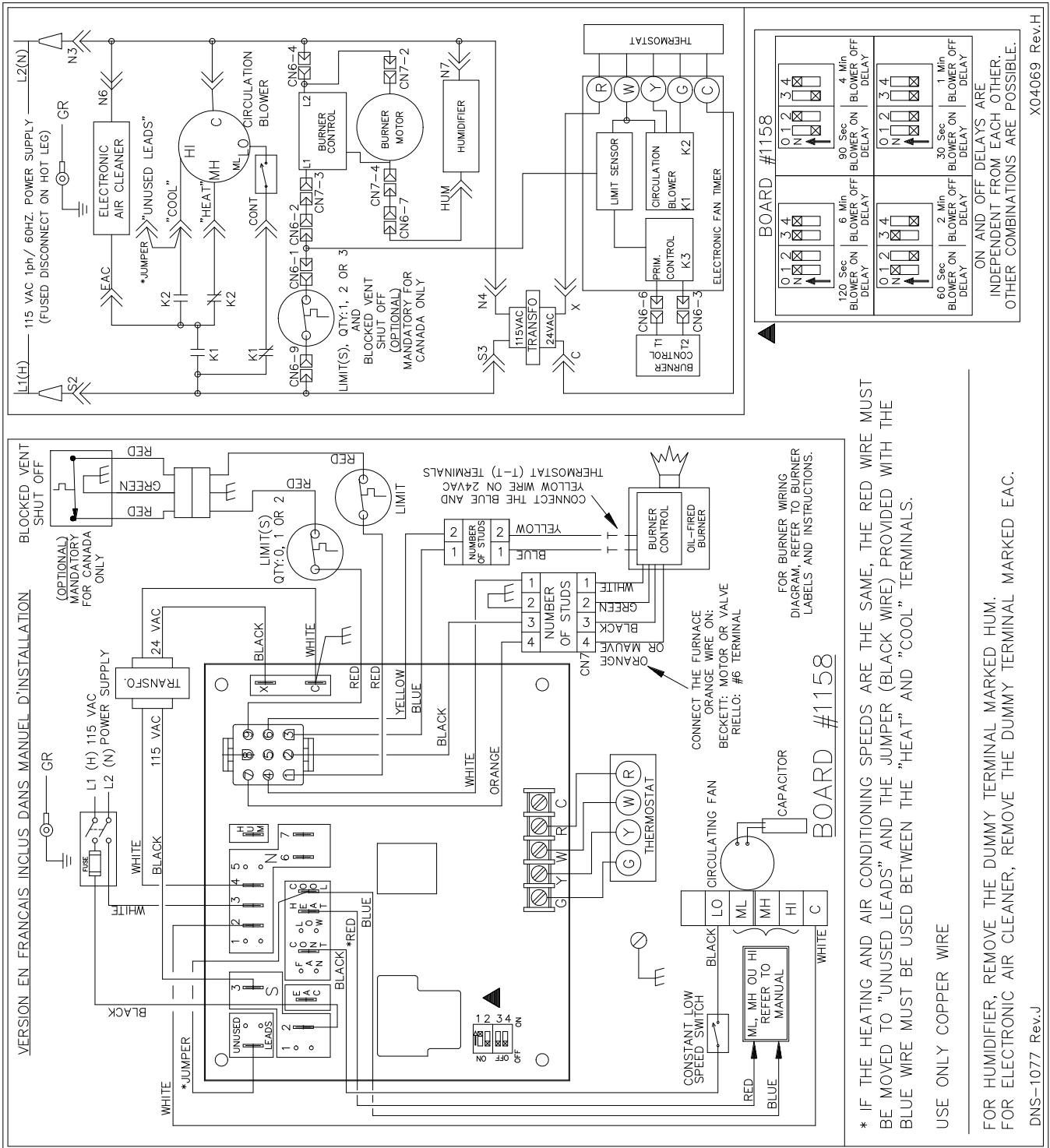

Figure 7: Wiring diagram, 4 speed motor (PSC)



X04069 Rev.H

DNS-1077 Rev.J

Figure 9: Parts list with 4 speed motor (PSC)

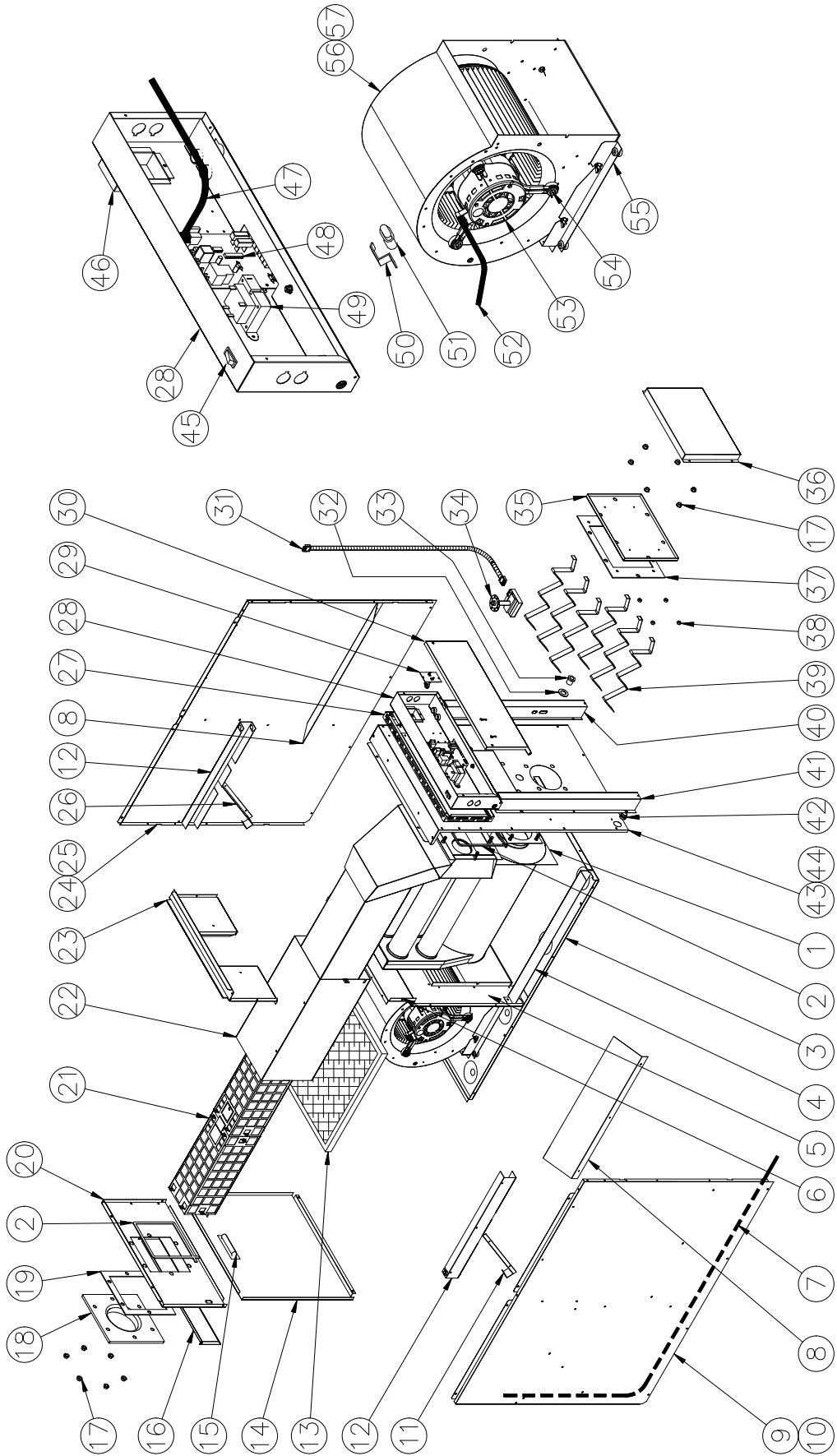

Table 11: Parts list with 4 speed motor (PSC)

Item	Part	Description	Comments
1	B03690	HEAT EXCHANGER ASSEMBLY	Heat exchanger only
2	J06L002	SEAL STRIP DIA 1/8" DIA X 25'	
3	B03696	FLOOR ASSEMBLY	
4	B03709	WIRE CHANNEL, INT	
5	B03695-01	LOWER BLOWER DIVIDER ASSEMBLY	Panel, 3 gaskets and baffle included
6	B03719	CENTER BLOWER DIVIDER	
7	B03335-02	ELECTRICAL KIT, BVSO INT	
8	B03708	SIDE BAFFLE	
9	B03694-02	LEFT SIDE PANEL ASSEMBLY	Panel, insulation and baffle included
10	B03714-02	LEFT SIDE PANEL INSULATION	
11	B03711-02	LEFT ANGLE FILTER RACK	
12	B03710	SIDE FILTER RACK	
13	Z04F004	PAPER FILTER 20 X 20 X 1	
14	B03697	BLOWER DOOR ASSEMBLY	Door, handle and label included
15	Z99F050	HANDLE, RECESSED BLACK	
16	B03577	REAR FILTER DOOR ASSEMBLY	
17	F07O001	HEX FLANGE NUT 3/8-16NC LAITON	
18	B01697	FLUE OUTLET FLANGE, 5" DIA.	
19	B01214	GASKET, SMOKE PIPE COVER	
20	B03693	TOP REAR PANEL ASSEMBLY	Panel and label included
21	B03718	REPLACEMENT SOUND TRAP ASSEMBLY	2 sections included
22	B03712	OUTLET PROTECTOR	
23	B03705	TOP DIVIDER	
24	B03694-01	RIGHT SIDE PANEL ASSEMBLY	Panel, insulation and baffle included
25	B03714-01	RIGHT SIDE PANEL INSULATION	
26	B03711-01	RIGHT ANGLE FILTER RACK	
27	B03553	ELECTRICAL BOX SPACER	
28	B03549	ELECTRICAL BOX	
29	R02R003	HIGH LIMIT L195-30F, 1.75 in.	
30	B03550	ELECTRICAL BOX COVER	Panel only
31	B03118-01	ELECTRICAL KIT, BVSO EXT	
32	F06F015	ZINC WASHER 1 7/16"	
33	Z99F061	SIGHT GLASS FOR HEAT EXCHANGER	
34	Z06G001	BLOCKED VENT SHUT-OFF BVSO-225	
35	B03587	CLEAN OUT ASSEMBLY	Item #37 included
36	B03574-01	PROTECTION COVER ASSEMBLY	cover and labels included
37	B03428	GASKET, SMOKE OUTLET	
38	F07F011	HEX NUT 3/8-16NC ZINC	
39	B03567	BAFFLE	6 baffles for complete kit
40	B03596	BURNER WIRE CHANEL	
41	B03554	WIRE CHANEL	
42	L04I010	STRAIN RELIEF BUSHING	
43	B03573	FRONT PANEL ASSEMBLY	Panel and insulation unclued
44	B03590	FRONT PANEL INSULATION	
45	L07F003	SWITCH SPST	
46	B03555	THERMO DISK PROTECTOR	
47	B03465	ELECTRICAL KIT (BOARD)	
48	R99G004	ELECTRONIC BOARD 1158	
49	L01F009	TRANSFORMER 120-24Volts, 40VA	
50	B01024	CAPACITOR HOLDER	
51	L01I002	CAPACITOR 7,5 MF	
52	B01664	ELECTRICAL KIT	
53	L06H004	MOTOR 1/2 HP, 4 SPEEDS DD	
54	B01889	MOTOR MOUNT ASSEMBLY	Legs, band and hardware included
55	B03713	BLOWER SUPPORT	
56	B03720-06	BLOWER 120-9T DD 0.50 PP	Housing, wheel and label included
57	B03717-01	REPLACEMENT BLOWER ASSEMBLY	Blower, motor and capacitor included
58	L01G009	CONTROL CARD FUSE - 3 AMPS	
ACCESSORIES			
VTK-54 VTK-098 KLAVT0101DET	VENT TERMINAL KIT 4"		For sealed combustion
IFV-410 IFV-098-10 KLAFV0101DET	4" INSULATED FLEX VENT 10ft		For sealed combustion
IFV-415	4" INSULATED FLEX VENT 15ft		For sealed combustion
IFV-420 IFV-098-20 KLAFV0201DET	4" INSULATED FLEX VENT 20ft		For sealed combustion
N01J055	BECKETT AFG BURNER (0.60-60W NOZZLE)		
N01J052 KLABR0201BEC	BECKETT NX BURNER (0.60-60W NOZZLE)		
N01F051 KLABR0301RLO	RIELLO 40-F5 BURNER (0.60-70A NOZZLE)		
N01F052 KLABR0401RLO	RIELLO 40-BF5 BURNER (0.60-70A NOZZLE)		For sealed combustion

B50093F

Figure 10: Parts list with variable speed motor (ECM)

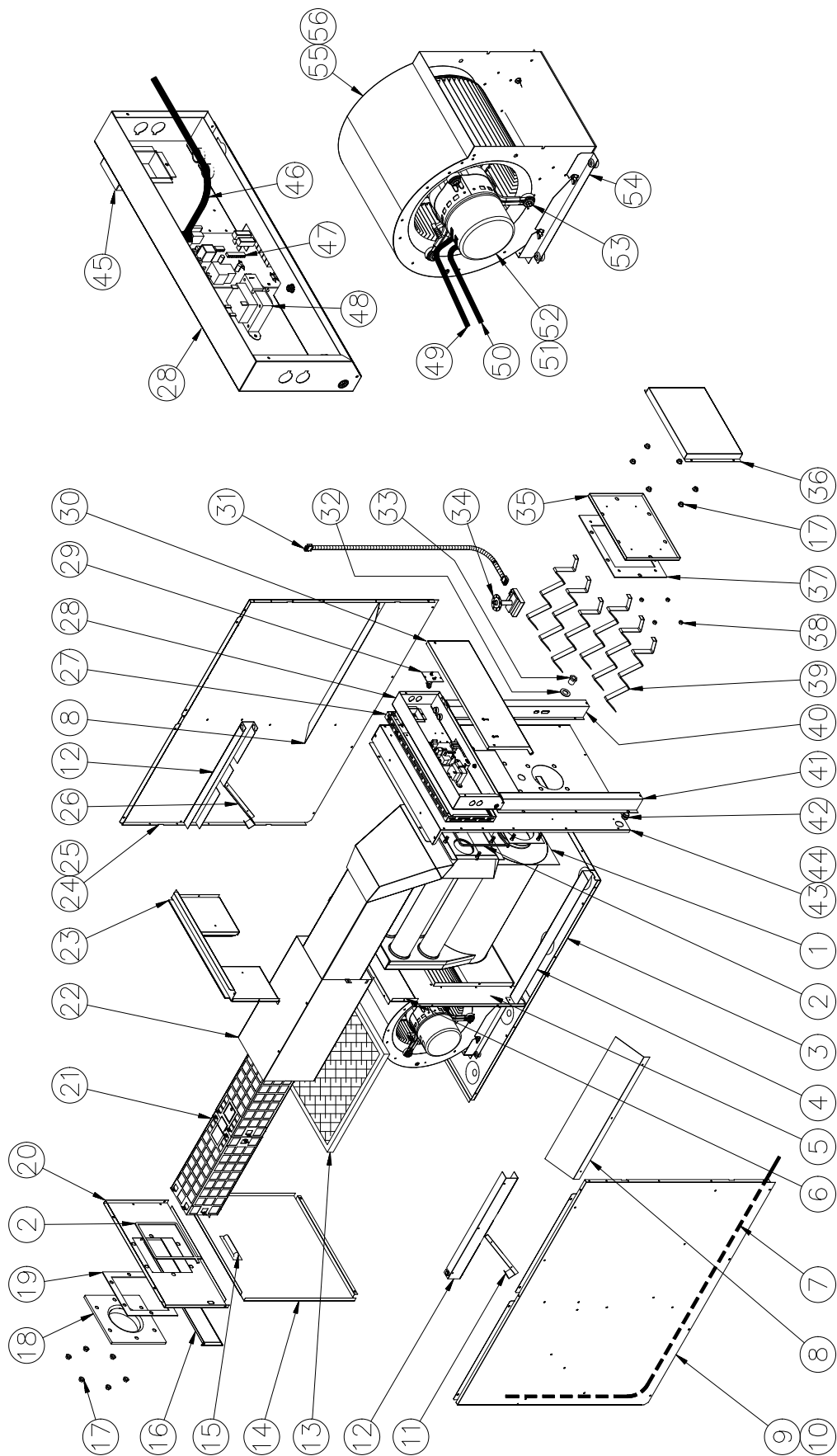

Table 12: Part lists with variable speed motor (ECM)

Part	Description	Comments
B03690	HEAT EXCHANGER ASSEMBLY	Heat exchanger only
J06L002	SEAL STRIP DIA 1/8" DIA X 25'	
B03696	FLOOR ASSEMBLY	
B03709	WIRE CHANNEL, INT	
B03695-01	LOWER BLOWER DIVIDER ASSEMBLY	Panel, 3 gaskets and baffle included
B03719	CENTER BLOWER DIVIDER	
B03335-02	ELECTRICAL KIT, BVSO INT	
B03708	SIDE BAFFLE	
B03694-02	LEFT SIDE PANEL ASSEMBLY	Panel, insulation and baffle included
B03714-02	LEFT SIDE PANEL INSULATION	
B03711-02	LEFT ANGLE FILTER RACK	
B03710	SIDE FILTER RACK	
Z04F004	PAPER FILTER 20 X 20 X 1	
B03697	BLOWER DOOR ASSEMBLY	Door, handle and labels included
Z99F050	HANDLE, RECESSED BLACK	
B03577	REAR FILTER DOOR ASSEMBLY	
F07O001	HEX FLANGE NUT 3/8-16NC LAITON	
B01697	FLUE OUTLET FLANGE, 5" DIA.	
B01214	GASKET, SMOKE PIPE COVER	
B03693	TOP REAR PANEL ASSEMBLY	Panel and label included
B03718	REPLACEMENT SOUND TRAP ASSEMBLY	2 sections included
B03712	OUTLET PROTECTOR	
B03705	TOP DIVIDER	
B03694-01	RIGHT SIDE PANEL ASSEMBLY	Panel, insulation and baffle included
B03714-01	RIGHT SIDE PANEL INSULATION	
B03711-01	RIGHT ANGLE FILTER RACK	
B03553	ELECTRICAL BOX SPACER	
B03534	ELECTRICAL BOX	
R02R003	HIGH LIMIT L195-30F, 1.75 in.	
B03550	ELECTRICAL BOX COVER	Panel only
B03118-01	ELECTRICAL KIT, BVSO EXT	
F06F015	ZINC WASHER 1 7/16"	
Z99F061	SIGHT GLASS FOR HEAT EXCHANGER	
Z06G001	BLOCKED VENT SHUT-OFF BVSO-225	
B03587	CLEAN OUT ASSEMBLY	Item #37 included
B03574-01	PROTECTION COVER ASSEMBLY	Cover and labels included
B03428	GASKET, SMOKE OUTLET	
F07F011	HEX NUT 3/8-16NC ZINC	
B03567	BAFFLE	6 baffles for complete kit
B03596	BURNER WIRE CHANEL	
B03554	WIRE CHANEL	
L04I010	STRAIN REL. BUSHING	
B03573	FRONT PANEL ASSEMBLY	Panel and insulation unclued
B03590	FRONT PANEL INSULATION	
B03555	THERMO DISK PROTECTOR	
B03465	ELECTRICAL KIT (BOARD)	
R99G003	ELECTRONIC BOARD 1168	
L01F009	TRANSFORMER 120-24Volts, 40VA	
B03243-01	ELECTRIC BLOWER KIT	
B03242-01	ELECTRONIC BLOWER KIT	
B03812-02	MOTOR 3/4 HP ECM	
"N/A"	MOTOR MODULE 1/2 ECM	
B01889	MOTOR MOUNT ASSEMBLY	Band, legs, nut & bolts included
B03713	BLOWER SUPPORT	
B03720-06	BLOWER 120-9T DD 0.5 PP	Housing, wheel and label included
B03717-02	REPLACEMENT BLOWER ASSEMBLY	Blower and motor included
L01G009	CONTROL CARD FUSE - 3 AMPS	
ACCESSORIES		
VTK-54 VTK-098 VT0101DET	VENT TERMINAL KIT 4"	For sealed combustion
IFV-410 V-098-10 FV0101DET	4" INSULATED FLEX VENT 10ft	For sealed combustion
IFV-415	4" INSULATED FLEX VENT 15ft	For sealed combustion
IFV-420 V-098-20 FV0201DET	4" INSULATED FLEX VENT 20ft	For sealed combustion
N01J055	BECKETT AFG BURNER (0.60-60W NOZZLE)	
N01J052 BR0201BEC	BECKETT NX BURNER (0.60-60W NOZZLE)	
N01F051 BR0301RLO	RIELLO 40-F5 BURNER (0.60-70A NOZZLE)	
N01F052 BR0401RLO	RIELLO 40-BF5 BURNER (0.60-70A NOZZLE)	For sealed combustion

B50094F