

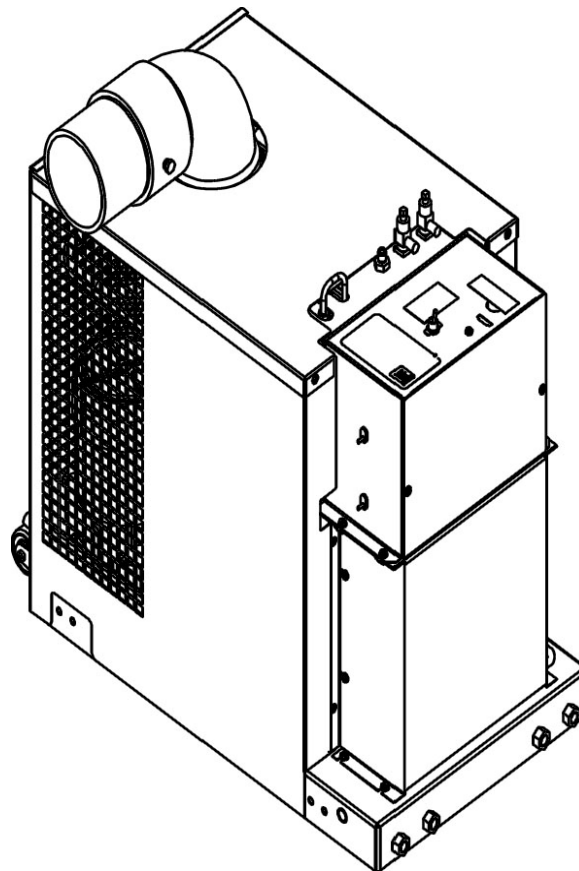

---

# UCR 700 SERIES CONTINUOUS FLOW ICEMAKER

## Installation/Service Manual



**Release Date:** May, 2001

**Publication Number:** 630460154

**Revision Date:** January 12, 2012

**Revision:** C

Visit the IMI Cornelius web site at [www.cornelius.com](http://www.cornelius.com) for all your Literature needs.

The products, technical information, and instructions contained in this manual are subject to change without notice. These instructions are not intended to cover all details or variations of the equipment, nor to provide for every possible contingency in the installation, operation or maintenance of this equipment. This manual assumes that the person(s) working on the equipment have been trained and are skilled in working with electrical, plumbing, pneumatic, and mechanical equipment. It is assumed that appropriate safety precautions are taken and that all local safety and construction requirements are being met, in addition to the information contained in this manual.

This Product is warranted only as provided in Cornelius' Commercial Warranty applicable to this Product and is subject to all of the restrictions and limitations contained in the Commercial Warranty.

Cornelius will not be responsible for any repair, replacement or other service required by or loss or damage resulting from any of the following occurrences, including but not limited to, (1) other than normal and proper use and normal service conditions with respect to the Product, (2) improper voltage, (3) inadequate wiring, (4) abuse, (5) accident, (6) alteration, (7) misuse, (8) neglect, (9) unauthorized repair or the failure to utilize suitably qualified and trained persons to perform service and/or repair of the Product, (10) improper cleaning, (11) failure to follow installation, operating, cleaning or maintenance instructions, (12) use of "non-authorized" parts (i.e., parts that are not 100% compatible with the Product) which use voids the entire warranty, (13) Product parts in contact with water or the product dispensed which are adversely impacted by changes in liquid scale or chemical composition.

### **Contact Information:**

To inquire about current revisions of this and other documentation or for assistance with any Cornelius product contact:

**[www.cornelius.com](http://www.cornelius.com)**

**800-238-3600**

### **Trademarks and Copyrights:**

This document contains proprietary information and it may not be reproduced in any way without permission from Cornelius.

Printed in U.S.A.

---

# TABLE OF CONTENTS

|  |          |
|--|----------|
| <b>Safety Instructions</b> .....                           | <b>1</b> |
| Read and Follow ALL Safety Instructions .....              | 1        |
| Safety Overview .....                                      | 1        |
| Recognition .....  | 1        |
| Different Types of Alerts .....                            | 1        |
| Safety Tips .....  | 1        |
| Qualified Service Personnel .....                          | 1        |
| Safety Precautions .....                                   | 2        |
| Shipping and Storage .....                                 | 2        |
| <b>General Description</b> .....                           | <b>3</b> |
| To the User of this Manual .....                           | 3        |
| Description .....  | 3        |
| Claims Instructions .....                                  | 3        |
| Warranty reference Information .....                       | 3        |
| Design Data .....  | 3        |
| Specification Chart .....                                  | 4        |
| <b>Installation</b> .....                                  | <b>6</b> |
| Pre-Installation .....                                     | 6        |
| Freight Damage Claim .....                                 | 6        |
| Counter .....  | 6        |
| Electrical .....   | 6        |
| Drain .....  | 6        |
| Installation .....   | 6        |
| Initial Start up, Checks and Adjustment Instructions ..... | 8        |
| <b>Guide to service</b> .....                              | <b>9</b> |
| Icemaker Cleaning and Sanitizing Procedures .....          | 9        |
| Maintenance .....  | 9        |
| Monthly .....  | 9        |
| Quarterly .....  | 9        |
| Semi-Annually .....  | 10       |
| Water Level Control .....                                  | 10       |
| How Water Level Control Works .....                        | 10       |
| Purpose .....  | 10       |
| To Replace Water Level Control .....                       | 11       |
| To Replace Water Level Safety Switch .....                 | 11       |
| Refrigeration System .....                                 | 11       |
| Refrigeration System Adjustments .....                     | 11       |
| Expansion Valve .....                                      | 12       |
| Adjustment and Troubleshooting .....                       | 12       |

---

|   |           |
|---|-----------|
| Condenser Modulating Valve .....              | 12        |
| Condenser Modulating Valve Removal .....      | 13        |
| Bin Control .....                             | 13        |
| Gearmotor .....                               | 14        |
| Motor Check .....                             | 15        |
| Start Relay .....                             | 15        |
| To Replace Gearmotor Assembly .....           | 15        |
| Auger and Extruding Head Removal .....        | 16        |
| Installation and Shaft Seal Replacement ..... | 16        |
| Upper Nut and Bearing Assembly .....          | 16        |
| To Replace Bearing .....                      | 17        |
| Electrical Checkout .....                     | 17        |
| Overload Check .....                          | 17        |
| Compressor Check .....                        | 17        |
| Capacitor Check .....                         | 18        |
| Safety Controls .....                         | 18        |
| <b>Troubleshooting .....</b>                  | <b>23</b> |
| Troubleshooting Compressors .....             | 23        |
| <b>Parts List .....</b>                       | <b>24</b> |

# SAFETY INSTRUCTIONS

## READ AND FOLLOW ALL SAFETY INSTRUCTIONS

### Safety Overview

- Read and follow **ALL SAFETY INSTRUCTIONS** in this manual and any warning/caution labels on the unit (decals, labels or laminated cards).
- Read and understand ALL applicable OSHA (Occupational Safety and Health Administration) safety regulations before operating this unit.

### Recognition

|   |
|---|
| <i>Recognize Safety Alerts</i>  |
|  <p><i>This is the safety alert symbol. When you see it in this manual or on the unit, be alert to the potential of personal injury or damage to the unit.</i></p> |

## DIFFERENT TYPES OF ALERTS

Indicates an immediate hazardous situation which if not avoided **WILL** result in serious injury, death or equipment damage.

### **WARNING:**

Indicates a potentially hazardous situation which, if not avoided, **COULD** result in serious injury, death, or equipment damage.

### **CAUTION:**

Indicates a potentially hazardous situation which, if not avoided, **MAY** result in minor or moderate injury or equipment damage.

## SAFETY TIPS

- Carefully read and follow all safety messages in this manual and safety signs on the unit.
- Keep safety signs in good condition and replace missing or damaged items.
- Learn how to operate the unit and how to use the controls properly.
- **Do not** let anyone operate the unit without proper training. This appliance is **not** intended for use by very young children or infirm persons without supervision. Young children should be supervised to ensure that they do not play with the appliance.
- Keep your unit in proper working condition and do not allow unauthorized modifications to the unit.

## QUALIFIED SERVICE PERSONNEL

### **WARNING:**

Only trained and certified electrical, plumbing and refrigeration technicians should service this unit. **ALL WIRING AND PLUMBING MUST CONFORM TO NATIONAL AND LOCAL CODES. FAILURE TO COMPLY COULD RESULT IN SERIOUS INJURY, DEATH OR EQUIPMENT DAMAGE.**

## SAFETY PRECAUTIONS

This unit has been specifically designed to provide protection against personal injury. To ensure continued protection observe the following:



### **WARNING:**

Disconnect power to the unit before servicing following all lock out/tag out procedures established by the user. Verify all of the power is off to the unit before any work is performed.

Failure to disconnect the power could result in serious injury, death or equipment damage.



### **CAUTION:**

Always be sure to keep area around the unit clean and free of clutter. Failure to keep this area clean may result in injury or equipment damage.

## SHIPPING AND STORAGE



### **CAUTION:**

Before shipping, storing, or relocating the unit, the unit must be sanitized and all sanitizing solution must be drained from the system. A freezing ambient environment will cause residual sanitizing solution or water remaining inside the unit to freeze resulting in damage to internal components.



# GENERAL DESCRIPTION

## TO THE USER OF THIS MANUAL

This manual covers the installation and assembly of the Air--Cooled or Water--Cooled Model UC700 Icemaker with the Model UC150 Dispenser. Refer to Table of Contents for page location of detailed information pertaining to questions that may arise during installation or operation of this equipment.

## DESCRIPTION

The UC700 is a chunklet Icemaker designed to be installed under a counter adjacent to an Ice Dispenser or an Ice Storage Bin. The Icemaker will deliver ice to either the left or right side. The Icemaker requires a 12--inch by 12--inch opening at the lower front of the Unit for air intake. A minimum of 1.5 sq. ft. opening must be provided out the left or right side and the rear of the machine for air exhaust.

## CLAIMS INSTRUCTIONS

Claims: In the event of shortage, notify the carrier as well as IMI Cornelius immediately. In the event of damage, notify the carrier. IMI Cornelius is not responsible for damage occurring in transit, but will gladly render assistance necessary to pursue your claim. Merchandise must be inspected for concealed damage within 15 days of receipt.

## WARRANTY REFERENCE INFORMATION

|   |
|---|
| <b>Warranty Registration Date</b><br>(to be filled out by customer) |
| Unit Part Number:   |
| Serial Number:  |
| Install Date:   |
| Local Authorized Service Center:                                    |

## DESIGN DATA

**Table 1. Design Data**

|  |            |
|--|------------|
| Unit Model Number:   |            |
| UCR700--A Series Continuous--Flow Icemaker (Air--Cooled)                   |            |
| UCR700--W Series Continuous--Flow Icemaker (Water--Cooled)                 |            |
| Unit Overall Dimensions:   |            |
| Height   | 27 inchs   |
| Width  | 15.7 inchs |
| Depth  | 25.5 inchs |
| Clearances Dimensions Required:  |            |
| Front Side Service Access (Removable front panel to allow removal of Unit) | 25 inchs   |
| Side Opposite Storage Bin for Air Exhaust                                  | 4 inchs    |
| Rear for Air Exhaust   |            |
| Weights:   |            |
| Shipping Weight  | 184 pounds |

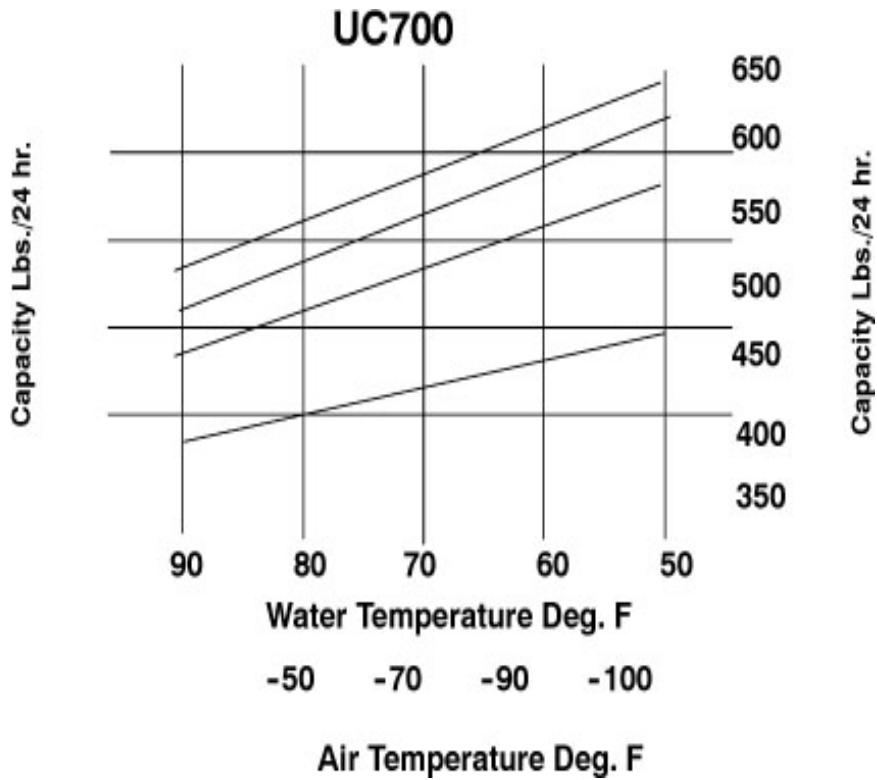

**Table 1. Design Data**

|   |  |
|---|--|
| Unit Model Number:  |  |
| Water Supply--Water inlet fitting is 1/4--inch SAE flare located at the top front of the Unit. The Unit is designed to operate on water pressure between 10 PSI and 90 PSI. |  |
| Drain Overflow Line (Located at rear of the Unit)   | 3/8--inch Flexible Tubing                                  |
| Ambient Operating Temperature   | 40° F to 100° F  |
| Electrical:   |  |
| Unit Electrical Rating  | 115 VAC, 60 Hz, 15.6 Amps, Single Phase                    |
| Recommended Electrical Supply   | 115 VAC, 60 hz, 20 Amps Dedicated 3--Wire Grounded Circuit |

### SPECIFICATION CHART

| Models    | Condensing Unit | VAC | HZ | PH | Wire | Comp. RLA | Fan Amps | GRMTR Amps | Refrigerant |       | Circuit Fuse |
|-----------|-----------------|-----|----|----|------|-----------|----------|------------|-------------|-------|--------------|
|           |                 |     |    |    |      |           |          |            | Oz.         | Type  |              |
| UCR700--A | Air Cooled      | 115 | 60 | 1  | 2    | 12        | 1.6      | 2          | 24          | R404A | 20           |
| UCR700--W | Water Cooled    | 115 | 60 | 1  | 2    | 12        | N/A      | 2          | 13          | R404A | 20           |



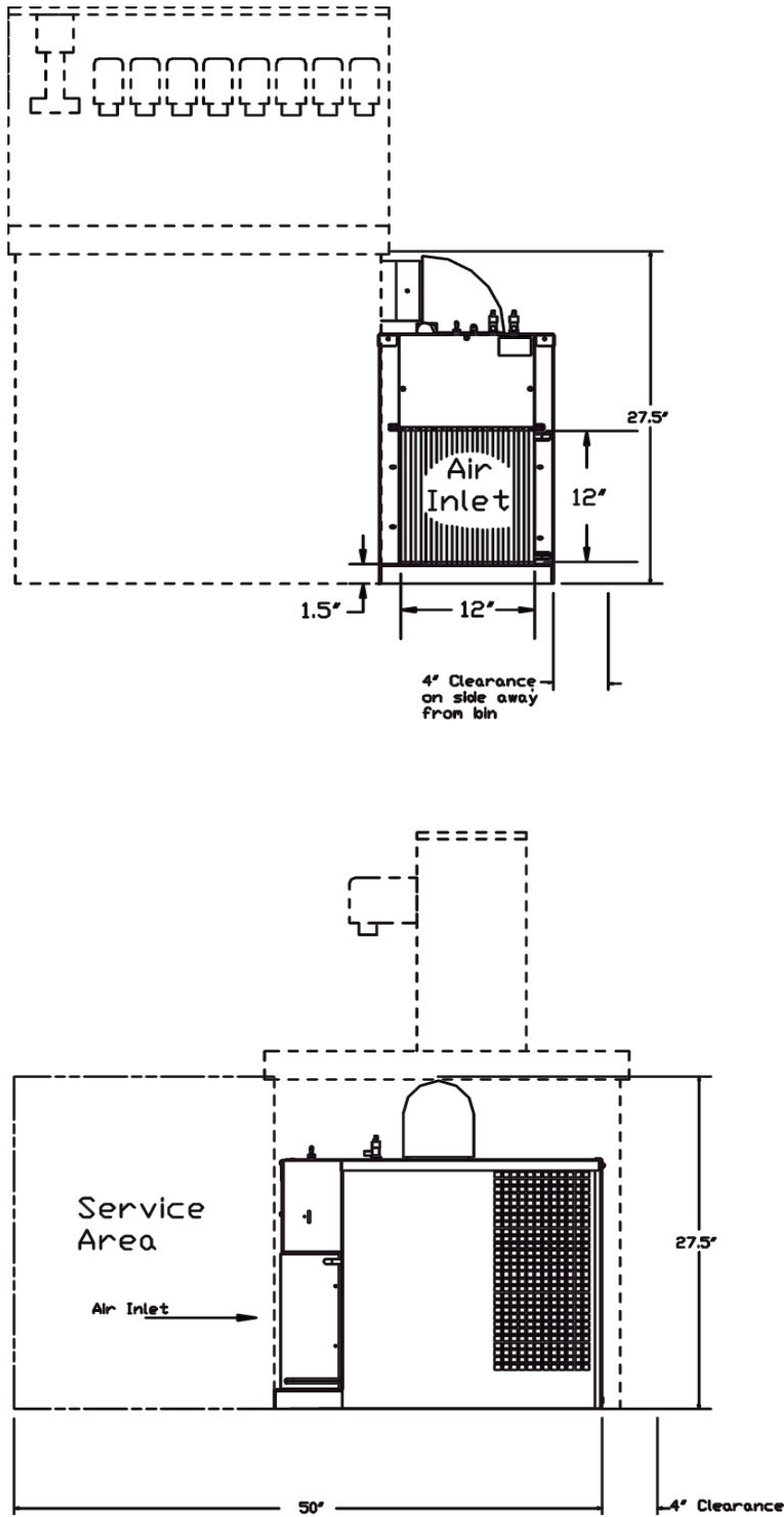

Figure 1. Clearance Requirements



# INSTALLATION

## PRE-INSTALLATION

### FREIGHT DAMAGE CLAIM

The delivery of your equipment (Freight Company, Distributor, or dealer) is responsible for loss or damage of your shipment. All claims must be filed with the deliverer of your equipment. Please follow the steps below to determine if your shipment is satisfactory or if a claim must be filed:

1. Check the number of products delivered against the number of products listed on the delivery receipt. Should the totals not match, have the driver note all errors on both copies and both you and the driver sign and date said notation.
2. Inspect all cartons for visible damage. Open and inspect as required before the driver leaves and have him or her note any damage on the receipts. All damaged claims must be inspected within 15 days of delivery. Notify your carrier immediately if concealed damage is found after delivery.
3. Should concealed damage be found when the product is unpacked, retain the packing material and the product and request an inspection from the deliverer.
4. All claims for loss or damage should be filed at once. Delays in filing will reduce the chance of achieving a satisfactory resolution to the claim.

## COUNTER

1. A flat and level counter space sufficiently strong to support the weight of the Dispenser and the Icemaker. The Icemaker may be installed on the left or the right side of the Dispenser.
2. General Requirements:
  - A. The front of the Icemaker must be free of obstructions.
  - B. Allow a 4--inch minimum clearance between exhaust side of the Icemaker and adjacent equipment.
  - C. A louvered front panel (12--inches X 12--inches) aligned with the air inlet of the Icemaker and adequate ventilation (1.5 Sq. feet opening) in the counter for exhaust air.
  - D. A removable panel in the counter face (from 2--inches below the top of the counter to the floor, a minimum of 19--inches wide) to allow removal of the Icemaker.

## ELECTRICAL

Two separate 20 amp, 120VAC, 60 Hz electrical circuits.

## DRAIN

One drain beneath the counter at floor level which will accommodate both the drain from the Icemaker and the Dispenser.

## INSTALLATION

1. Keep unit in the upright position, remove carton and pallet from the Icemaker and inspect for damage. If any damage is found, file a claim with carrier immediately.
2. Locate startup card either on outside of container or on plastic liner. Fill in proper information and send one to factory, and other copy to distributor. Postage is prepaid.
3. Install the Dispenser first, following installation instructions supplied with the Dispenser.
4. Remove the two hole plugs from the side of the dispenser.

- A. The plugs are pressed in and sealed with a silastic sealant. To remove pry the outside cap off and then press the inside plug into the bin. Discard both plugs.
  - B. Install the icemaker alignment brackets (Supplied with icemaker) to the dispenser (See Figure 2).
5. Install the Icemaker:
- A. Install the icemaker alignment brackets (Supplied with icemaker) to the icemaker (See Figure 2).
  - B. Roll the Icemaker into the cabinet alongside the Dispenser.
  - C. Level and align the icemaker to the dispenser using the four level adjustment bolts located on the lower front of the Icemaker.
  - D. Install the locking bolt on the lower front of the icemaker.
  - E. Connect drain, power and water.
6. Install transport tube:
- A. Insert the ice transport tube through the bin into the transport elbow on the Icemaker. (**Note:** The icemaker is equipped with a safety switch located at the base of the elbow, this switch will prevent the icemaker from running if the elbow is not properly installed).
  - B. Align the nylon lock screw on the elbow with the recess on the tube. Install lock screw.
7. Connect bin thermostat:
- A. Locate bin thermostat cable supplied with the icemaker (Black cable) and connect to electrical box on the UCR700 and the receptacle on the side of the dispenser.

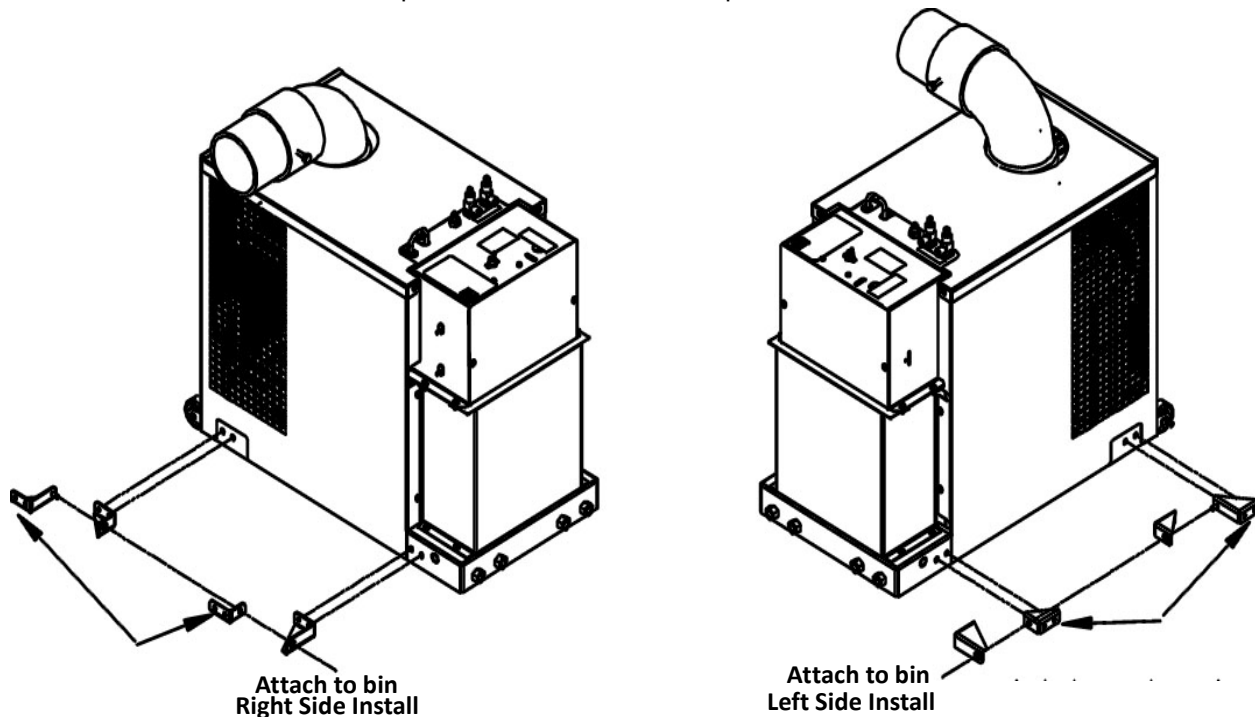

Figure 2. Side Bracket Installation

## INITIAL START UP, CHECKS AND ADJUSTMENT INSTRUCTIONS

**NOTE: Do not start Icemaker before completing installation steps on pages 7 and 9.**

Turn on water supply (if Icemaker is water cooled turn water on to condenser also) turn on main power switch (located on top of electrical box), and make the following system checks:

**NOTE: If Icemaker will not start be sure water reservoir is full. Low water safety control must be properly adjusted to start and shut down the Icemaker. If water level drops below bottom of reservoir, the Icemaker must shut down. Adjustment is made by moving magnet up or down.**

**Water Level**—If necessary adjust float by bending float arm up or down as needed, push float assembly down until Icemaker stops running. Release float and Icemaker will restart. Keep water in reservoir at level line while the Icemaker is in operation. (See Figure 3)

**Low Water Safety Control**—Adjust magnet by bending magnet arm as needed to shut unit down if water level drops below bottom of reservoir.

**Bin Control**—Place ice around probe, unit should shut down in one minute. Remove ice from around probe, unit should start in two minutes.

**NOTE: For altitudes over 1000 feet above sea level, adjust range screw (behind end cover). Half turn max. raises setting 4\_F approx.**

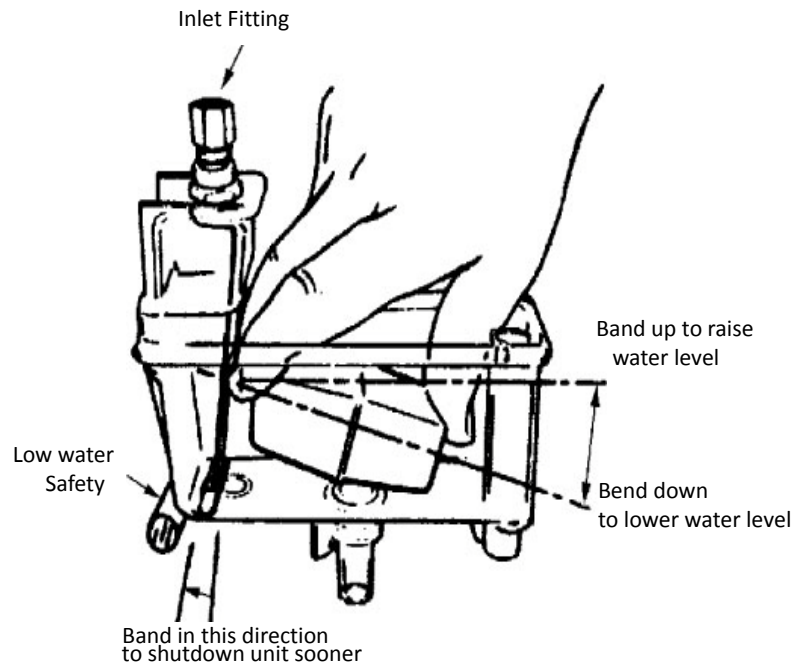

**Figure 3. Icemaker Float Assembly**

**Water modulating valve (water cooled units only)**—Opening point of condenser water modulating valve should be set to maintain proper operating pressure in the refrigeration system high side. (see chart on page 13). Closing point of valve should be set low enough to close valve during compressor stand by periods. To raise, turn counterclockwise, to lower turn clockwise.

# GUIDE TO SERVICE

## **WARNING:**

Disconnect electrical power to the Icemaker to prevent personal injury before attempting any internal maintenance. Only qualified personnel should service internal components or electrical wiring.

## ICEMAKER CLEANING AND SANITIZING PROCEDURES

### **CAUTION:**

Do not use any of the ice made during cleaning operations. Clean and sanitize ice storage area when cleaning icemaker.

1. Turn machine off.
2. Shut off water supply.
3. Remove ice from storage bin.
4. Mix approved cleaner (2 gallons as directed). Recommended cleaner: Calgon Corp. of Virginia Chemicals, ice machine cleaner. Mixture: 3-1/3 ounces per gallon of water.
5. Clean auger assembly and ice transition tube in a sink using cleaner mixture and reinstall in icemaker.
6. Turn machine on and add cleaner solution to water level control until 2 gallons have been used.
7. Turn on water supply and run machine for 15 minutes.
8. Turn off machine and remove all ice.
9. Sanitize using household liquid bleach (50 ppm chlorine). Mixture: 1 fluid ounce per gallon room temperature water. 2 minute exposure time.
10. Sanitize auger assembly and ice transition tube in a sink using sanitizing solution and reinstall in icemaker.
11. Fill icemaker with sanitizer by slowly pouring solution into water feed reservoir until full. Solution will drain through overflow tube. Do not run machine. Allow to air dry.
12. If icemaker is used in conjunction with ice dispenser or storage bin, follow manufacturer's recommended cleaning instructions at this time.

## MAINTENANCE

Preventive maintenance can increase the trouble free life of your icemaker. Many authorized service agencies offer service contracts for your icemaker. Contact your local distributor for further information.

### MONTHLY

1. Clean the condenser. Use a brush, vacuum cleaner or blow from inside with air or CO<sub>2</sub> gas.
2. Inspect water feed reservoir at least once a month until a definite pattern for cleaning and sanitizing has been established.

### QUARTERLY

This is the maximum period of time between cleaning and sanitizing the icemaker. In addition to recommended monthly procedure, and if a more frequent cleaning and sanitizing pattern has not been established, unit must be cleaned and sanitized.

## SEMI-ANNUALLY

Semi-Annually in addition to all previously established service procedures perform the following:

1. Check for water leaks in tube connections, water fittings and lower Ice maker water seal.
2. Check drain tubes for clogs and aged tubes. Replace if tubes are stained or brittle.
3. Check for signs of condensation. Clean where necessary and replace insulation properly.
4. Check safety circuits for proper operation.
5. Check refrigeration system (see page 11).
6. Check unit for abnormal noise. Tighten machine and cabinet screws, if necessary.
7. Check white upper bearings on auger assembly. If bearings are less than 1/16" thick, replace. See Figure 4

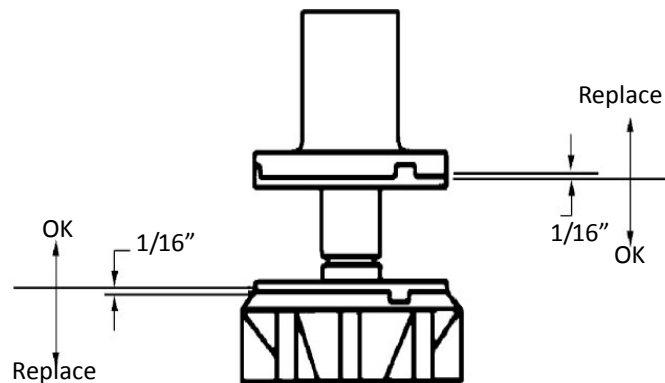

Figure 4. Upper Nut and Bearing Assembly

## WATER LEVEL CONTROL

### HOW WATER LEVEL CONTROL WORKS

When water is introduced through the inlet fitting the float rises. the float pushes against a lever which in turn forces the poppet assembly against the inlet fitting valve seat which seals the water off. See Figure 3 Before the water inlet is sealed the safety switch is operated. In the event of a water failure the float would drop down and operate the safety switch to shut off the machine.

If water level control will not shut off and seal at level as indicated, be sure inlet pressure does not exceed recommended factory operating range.

Under ordinary circumstances adjustment should not be necessary providing it was properly adjusted when unit was installed or relocated. If, however, the control becomes inoperative, repair or replace. See Start-Up Adjustment, page 9.

### PURPOSE

1. To automatically maintain proper water level in the evaporator when unit is running and making ice.
2. A safety switch is operated in the event of an interruption in water supply. The switch shuts off the electrical power to the icemaker and its refrigeration system. Switch will reset as soon as cause of water failure has been corrected and proper water level in icemaker has again been reached.
3. The transparent bowl not only provides a visible check of water level, but also is a good guide to the internal conditions which exist within the icemaker assembly itself. (See Cleaning Procedure.)

## TO REPLACE WATER LEVEL CONTROL

1. Shut off the water supply. Shut off the main power switch or unplug the ice dispenser from electrical outlet.
2. Remove the flexible tubing from bottom of water level control and drain water from water level control and evaporator.
3. Remove flexible tubing at bottom of water level bowl connected to the overflow.
4. Hold water inlet fitting with proper tool to prevent it from rotating when disconnecting the water inlet.
5. Remove wing nut holding water control to its mounting bracket. Control can be removed by lifting straight up.

## TO REPLACE WATER LEVEL SAFETY SWITCH

1. Shut off main power switch or unplug the ice dispenser from electrical outlet.
2. Unplug molex connector connecting switch to electrical box.
3. Remove the 2 screws anchoring the water level safety switch to the bottom of the water level control mounting bracket.

## REFRIGERATION SYSTEM

**NOTE: Thermostatic Expansion Valve No Adjustment**

**±10 Lbs Discharge Pressure**

**WATER TEMPERATURE**

|                  |      |     |     |     |
|------------------|------|-----|-----|-----|
|                  |      | 40° | 65° | 90° |
| A<br>I<br>R      | 50°  | 174 | 177 | 180 |
|                  | 60°  | 202 | 205 | 208 |
|                  | 70°  | 230 | 233 | 236 |
|                  | 80°  | 265 | 269 | 272 |
| T<br>E<br>M<br>P | 90°  | 300 | 304 | 307 |
|                  | 100° | 328 | 334 | 340 |
|                  |      |     |     |     |

## REFRIGERATION SYSTEM ADJUSTMENTS

A complete understanding of the icemaker and hermetic refrigeration system is necessary before any adjustments are made. The refrigeration technician must use high and low side pressure readings, water and air temperatures, plus general conditions of cleanliness to assess the refrigeration system status when making any adjustments.

All icemaker products are tested and adjusted at the factory prior to shipment where the ambient temperature ranges from 65\_ to 90\_ F, depending on the season of the year.

Whenever a new icemaker product is initially installed and started-up, it is imperative that the start-up operation make the following checks and/or readjustments for local conditions.

## EXPANSION VALVE

You will find a thermostatic expansion valve on icemakers, which is used to control the amount of refrigerant flowing through the evaporator. Improperly installed or defective expansion valves may cause low production, soft ice, squeaking from evaporator and excessive load inside evaporator.

By using general refrigeration system troubleshooting along with the pressure charts you can easily determine whether or not the expansion valve is working properly.

## ADJUSTMENT AND TROUBLESHOOTING

When troubleshooting the expansion valve you must first be sure you have adequate water flowing into evaporator, a clean condenser, unit is properly ventilated, and system is properly charged and free from any restrictions. Also be sure compressor is operating properly.

Second, take reservoir water temperature and air temperature from condenser inlet and determine at what pressure unit should be running. Machines are equipped with thermostatic valves, there is NO adjustment. If correct pressure cannot be obtained, first be sure system has time to stabilize 10-15 minutes. Second, be sure sensing bulb is located at 12:00 position on outlet side of evaporator about 3-4 inches away from evaporator and be sure to insulate well and clamp tightly to tubing. If system pressures are still not adequate, take a second water and air temperature reading and go over other parts of system for possible problems. If proper charge is questionable evacuate and recharge to nameplate and leak check. If valve still malfunctions replace valve. When replacing valve be sure to bleed refrigerant gas from low side port so as not to lose refrigerant oil. Use general refrigerant system practices when replacing and recharging unit. After new valve is in place, go through previous monitored adjustments and troubleshooting to be sure valve is functioning properly.

**NOTE: Units with thermostatic expansion valve—The valve is located on bottom refrigerant line. Sensing bulb is located on top refrigerant line. On water cooled units adjust condenser modulating valve before troubleshooting expansion valve.**



### CAUTION:

Very high discharge pressure is present in system. Quick disconnects on your gauges will minimize danger and loss of refrigerant. Comply with federal regulations for reclaiming refrigerant.

## CONDENSER MODULATING VALVE

The reason for using a water modulating valve is to supply the correct amount of water to the condenser. and to maintain a proper operating pressure to refrigeration system high side.

The flow of water through the valve is increased as the high side pressure rises and is decreased as high side pressure lowers. To calibrate the amount of water flow with the refrigeration system high side pressure, turn adjustment screw located on end of valve opposite of bellows. See Figure 6. Turn screw counterclockwise to raise opening point or clockwise to lower opening point. Opening point of valve should be set to maintain proper operating pressure in refrigeration system high side. Refer to Pressure Chart on page 3. Closing point of valve should be set low enough to close valve during compressor stand-by periods.

**NOTE: Cold water will absorb heat faster than warm water. The water flow will therefore automatically increase as inlet temperature increases.**

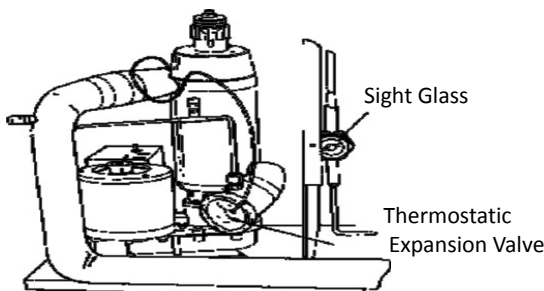

Figure 5. Expansion Valve

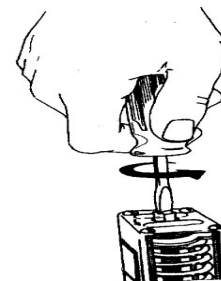

Figure 6. Adjustment Screw



## CONDENSER MODULATING VALVE REMOVAL

1. Disconnect power to unit, then shut off water supply to condenser and evacuate refrigerant from system.
2. Remove inlet water line from Condenser Modulating Valve. Also remove tube from high side refrigerant line.
3. Remove Condenser Modulating Valve and bracket from unit.
4. Remove valve from bracket.
5. Replace Condenser Modulating Valve by reversing Steps 2 thru 4. Then pull system into vacuum.
6. Charge unit with proper amount of refrigeration.
7. Turn power and water on to unit.
8. With unit running, adjust modulating valve to proper setting.
9. Go through a complete system check.

## BIN CONTROL

The type of bin control used on all UC Models is thermostatically controlled. The switch itself is inside the electrical box of the Dispenser and can be serviced from the front of the unit. The cap tube bulb is located in the thermostat well directly under the ice inlet.

To test switch, disconnect power to unit and remove one wire from switch. Connect both leads of your ohmmeter to the Bin Control Switch terminals. With control bulb at room temperature ohmmeter should read "Closed Circuit".

Now cover the control bulb with ice, within 1 minute switch should "click" and ohmmeter should read "Open Circuit." The Bin control is in electrical series with a 24 volt transformer located in the ice dispenser and a 24 volt control relay located in the Ice maker.

The Bin 24 volt control relay is in electrical series with coil on antifreeze relay along with the low water safety. If unit is water cooled, the condenser high pressure cut out is also in series.

The Control Switch is held in place inside electrical box by 2 screws. Control bulb is positioned under ice chute and can be replaced by removing the capillary from the thermostat well.

The most important thing to remember when replacing probe is to be careful not to cut or kink probe and be sure sensor bulb is located in a position to shut unit down before ice reaches ice chute.

This icemaker is equipped with a safety ice level sensor. This sensor control is located on top of the evaporator. This switch is also in electrical series with the anti-freeze relay and other safety circuitry.

## GEARMOTOR

The gearmotor is equipped with a start relay and a manual reset overload.

When current is applied, the relay energizes and completes the circuit to the start winding. The motor reaches a predetermined speed and the relay drops out, disconnecting the start winding. The run winding remains in the circuit as long as current is applied.

The purpose of the overload is to automatically shut off the motor in the event of a mechanical bind of the transmission, an overload condition within the evaporator or an electrical malfunction. It does this by sensing amperage draw. If the motor stalls the start relay would energize and stay energized. The amperage would surge 5 to 6 times greater than the normal draw. In this event the overload would shut off the transmission in 4 to 8 seconds.

If the motor is subjected to an abnormal load, but does not reach a stall condition, the overload will react, but over a greater period of time. The reaction time depends upon the amperage to which it is subjected.

The overload, through the safety circuit, also shuts off the compressor.

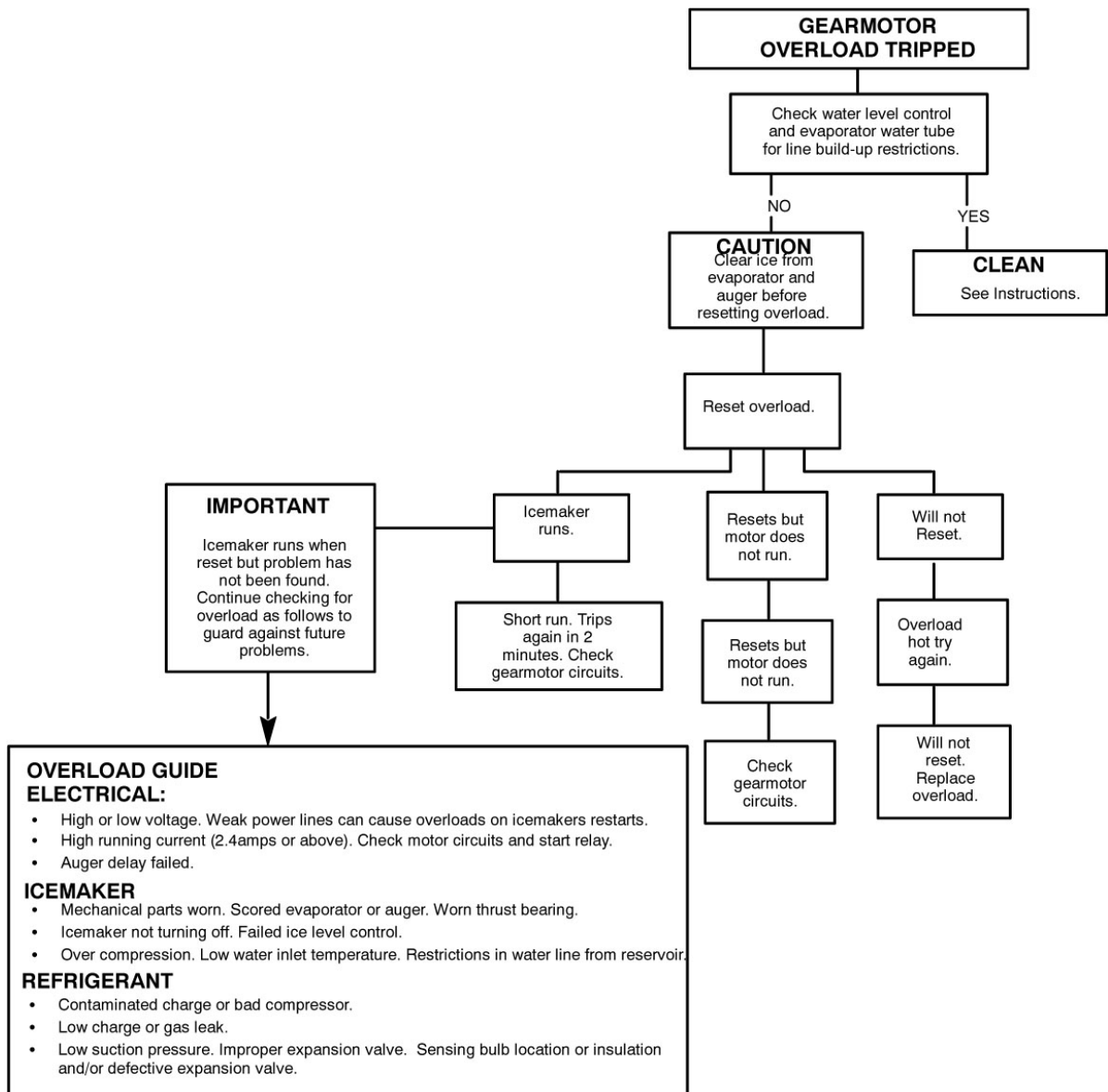

## MOTOR CHECK

The resistance readings on the winding will be between 5 to 25 ohms. A meter capable of these low readings must be used. The start relay cover must be removed. (See Figure 7).

If no continuity on start or run winding test, replace gearmotor. If continuity on grounded motor test, replace gearmotor.

## START RELAY

1. Check between "2" and "4" on relay (with relay unplugged). If there is continuity replace the relay, as the relay contacts should be open.
2. Check between "3" and "4" on relay, if no continuity replace the relay.

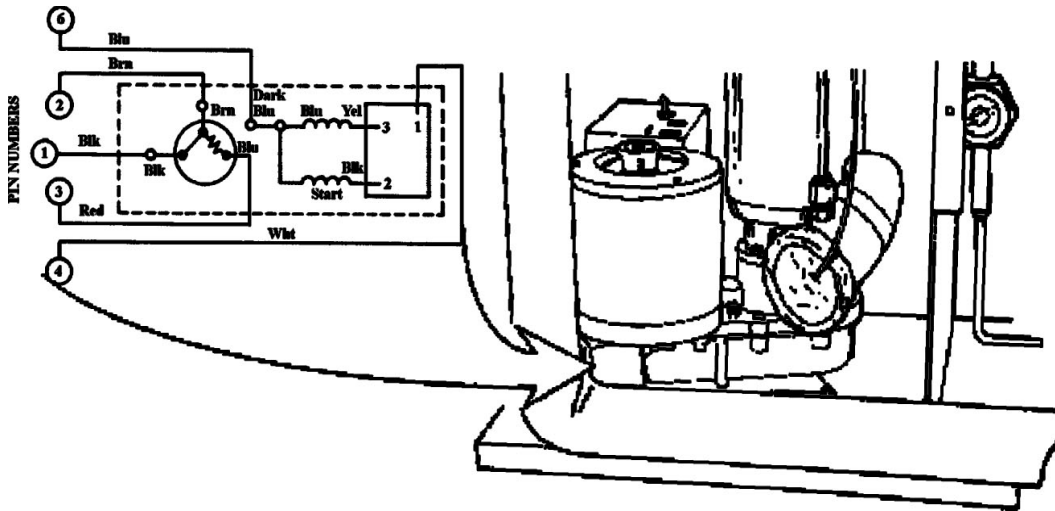

Figure 7. Gearmotor Assembly

## TO REPLACE GEARMOTOR ASSEMBLY

1. Disconnect the icemaker from the electrical power source.
2. Disconnect the transmission cable from the electrical box.
3. Remove the 4 hex head bolts securing the evaporator to the top of the transmission.
4. Remove the 4 bolt's holding the transmission and bracket to frame base, while supporting the weight of the evaporator. Remove the transmission from the unit.
5. When replacing the transmission, it may be necessary to rotate the auger back and forth to align the motor shaft and auger.

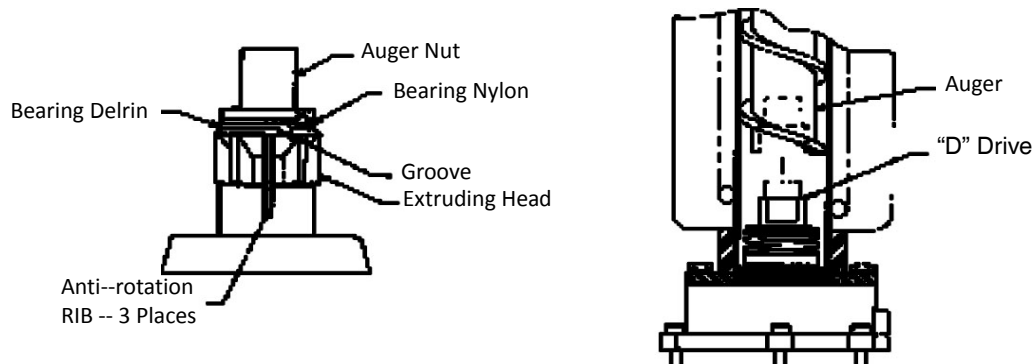

Figure 8. Auger and Extruding Head Removal

## AUGER AND EXTRUDING HEAD REMOVAL

1. Disconnect unit from power supply.
2. Remove storage container cover and put aside.
3. Turn off water supply to icemaker.
4. After ice has melted from head take hold of the auger nut and lift straight up to disengage from icemaker.
5. When replacing the auger assembly, make certain that both the auger engages the output shaft drive and the extruding head ribs engage the evaporator tube. (See Figure 8)

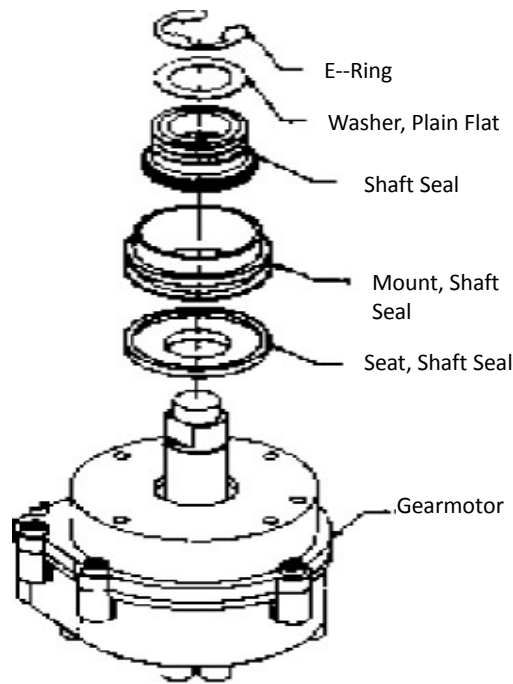

Figure 9. Shaft Seal

## INSTALLATION AND SHAFT SEAL REPLACEMENT See (Figure 9)

1. Place shaft seal locator seat and shaft seal mount over gearmotor output shaft and push down until shaft seal seat and shaft seal mount rest flush on top of gearmotor.
2. Place rubber coated ceramic seal (important: ceramic face up) over output shaft and push down until seal nest in recess of shaft seal mount. (lubricate rubber on ceramic seal with rubber lubricant).
3. Place shaft seal with carbon face down (spring up) over output shaft and push (gently) downward until seal rests on carbon face of the output shaft seal.
4. Place flat washer over output shaft and let rest on the output shaft seal. Push down on the washer compressing the spring on the output shaft seal. While holding the seals (down) in place slide the E-ring into the groove on the output shaft.

## UPPER NUT AND BEARING ASSEMBLY

The upper white bearing located on top of the auger is used to absorb the force between the auger and extruding head.

**NOTE: The bearings are 3/32" thick. When they wear below 1/16" they should be replaced. Bearings to be inspected for wear during quarterly maintenance. (See Figure 4)**

## TO REPLACE BEARING

1. Disconnect unit from electric power.
2. Remove top panels.
3. Remove Dispense Tray Cover.
4. Use an open end wrench on auger nut connected to bearing and turn counterclockwise to remove assembly.
5. Remove worn bearings. Replace with new bearings and then reinstall assembly.

**NOTE:** If auger turns with nut, remove cover on top of gearmotor stator and hold motor while loosening nut.



Figure 10. Overload Check

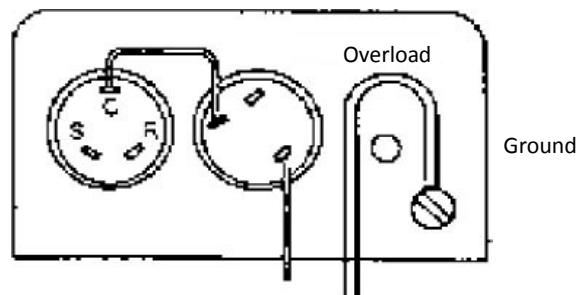

Figure 11. Compressor Check

## ELECTRICAL CHECKOUT

1. Be sure the unit is disconnected from the power source. Remove the compressor electrical box cover. Check for obvious damage and loose wires.
2. Disconnect the fan motor leads. Since capacitors store energy, short the capacitor with a screwdriver. This will prevent shocks.
3. Disconnect the compressor terminal wires.

### OVERLOAD CHECK (See Figure 10)

Using a volt-ohmmeter check the continuity across the overload, contact #1 and # 3. If none, wait for unit to cool down and try again. If still no continuity, the overload protector is defective and should be replaced.

### COMPRESSOR CHECK (See Figure 11)

The resistance readings on the windings will be between 0.25 to 10.00 ohms, a meter capable of these low readings must be used.

1. Check between "C" and "R." Replace the compressor if there is no continuity as the run windings are open.
2. Check between "C" and "S." Replace the compressor if there is no continuity as the start windings are open.
3. Check between "C" and "R" or "S" and the shell of the compressor. If there is continuity, replace the compressor as the motor is grounded.
4. Check between screw terminal on the overload and "C" on the compressor. Check and repair the lead or connections if there is no continuity.

## CAPACITOR CHECK

1. Check or replace start capacitor, disconnect bleed resistor before checking for shorted capacitor.
2. Check or replace run capacitor (if supplied) check for shorted capacitor or either terminal grounded to case.

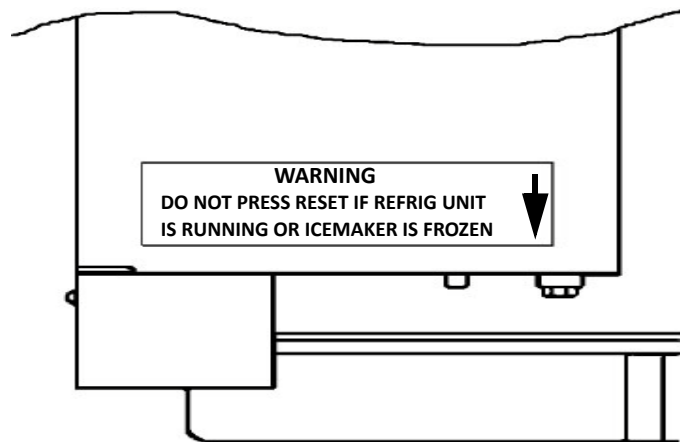

Figure 12. Gear Motor Overload

## SAFETY CONTROLS

Your icemaker unit has several safety and control devices incorporated into its design.



### WARNING:

None of the below described devices should ever be “bypassed” to allow the unit to function.

The safety and control system shut-off devices are:

1. Low water shut off reed switch located in icemaker float assembly. (Automatic reset type.) See Figure 3
2. Gearmotor thermal overload, manual reset type (red button on motor). See Wiring Diagram Figure 13.
3. Compressor thermal overload, automatic reset type. See Figure 10
4. Anti-freeze relay and associated circuit. See Wiring Diagram Figure 13.
5. Main service switch located on top of the control box. See Wiring diagram Figure 13.
6. Bin Control.
7. High pressure cut out (water cooled only).



**GUIDE TO GOOD ICE**

**CUSTOMER COMMENTS**

**CHECK ICEMAKER LOCATION CONDITIONS FIRST**

**CHECK ICE MAKER**

“It runs but the ice is too soft.”  
 “The icemaker is not producing enough ice.”  
 “The ice is too wet.”



- Proper air flow for condensing system.
- Location too close to high units such as coffee urns, deep fryers, grills, etc.
- Supply water conditions
  - Water too warm (above 90°F).
  - Water artificially softened above 262 ppm sodium chloride.
  - Normal water supply too high in total dissolved solids (above 500 PPM).

- Use gauges for checking suction and head pressures. See manual for correct reading and conditions. Check frost line and sight glass.
- Check water level for proper adjustment and restrictions. See Manual.
- Check evaporator assembly for worn parts, bearings, scored evaporator and auger, bad expansion valve, etc.

“It makes too much noise.”  
 (With this comment the ice is usually extremely hard and larger than normal.)



Over Compression

- Check to see if noise objection is normal fan and air flow noise.
- Supply water conditions.
  - Water too cold (below 50°F). (Possibly running from pre-cooler.)
- Obstructions partially blocking ice exit from top of evaporator.
- Check fan and fan shroud.

- Check for loose parts and screws rattling.
- Check evaporator assembly for worn parts, bearings, scored evaporator and auger, bad expansion valve, etc.

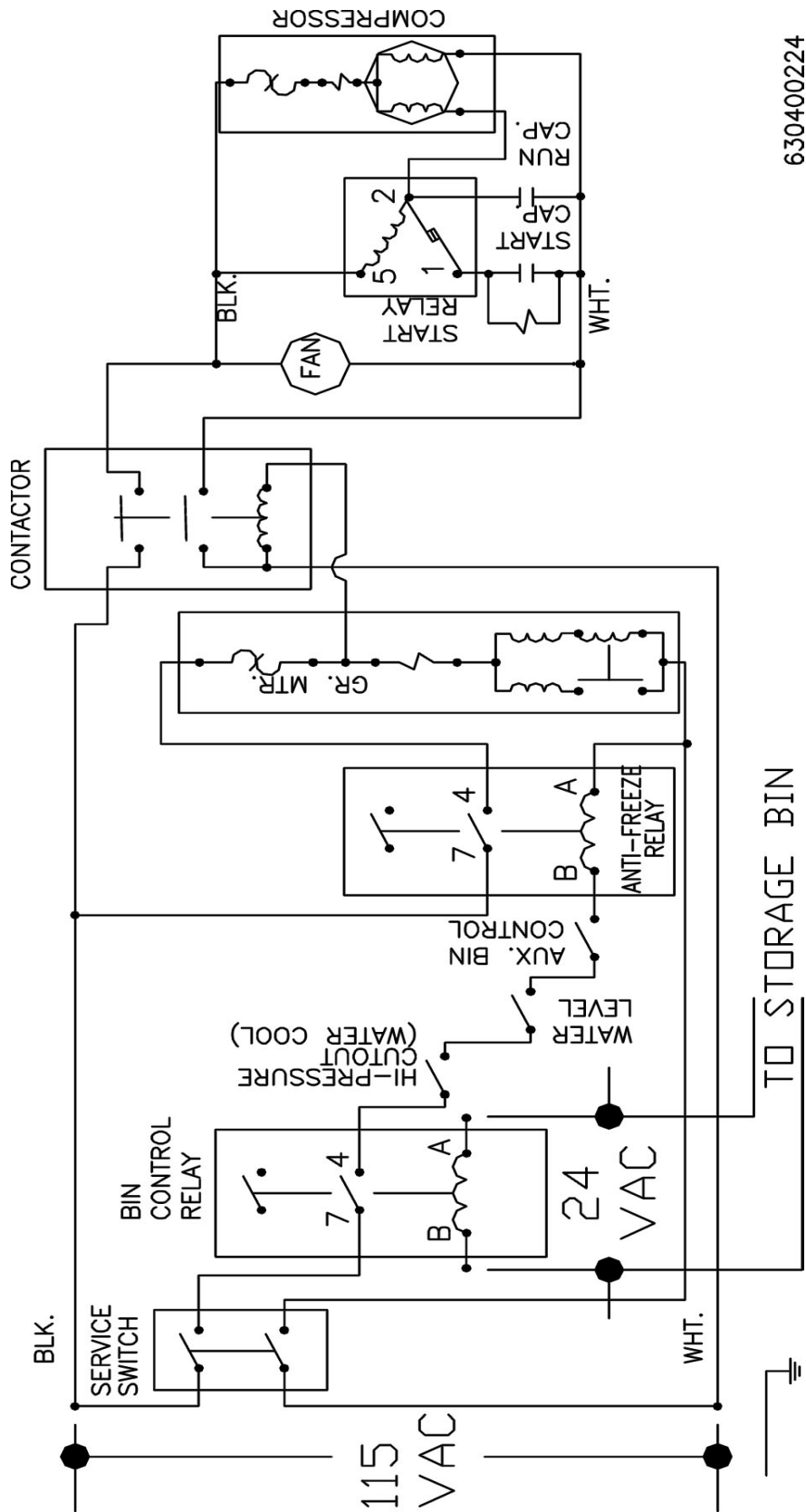

630400224

Figure 13. Wiring Diagram

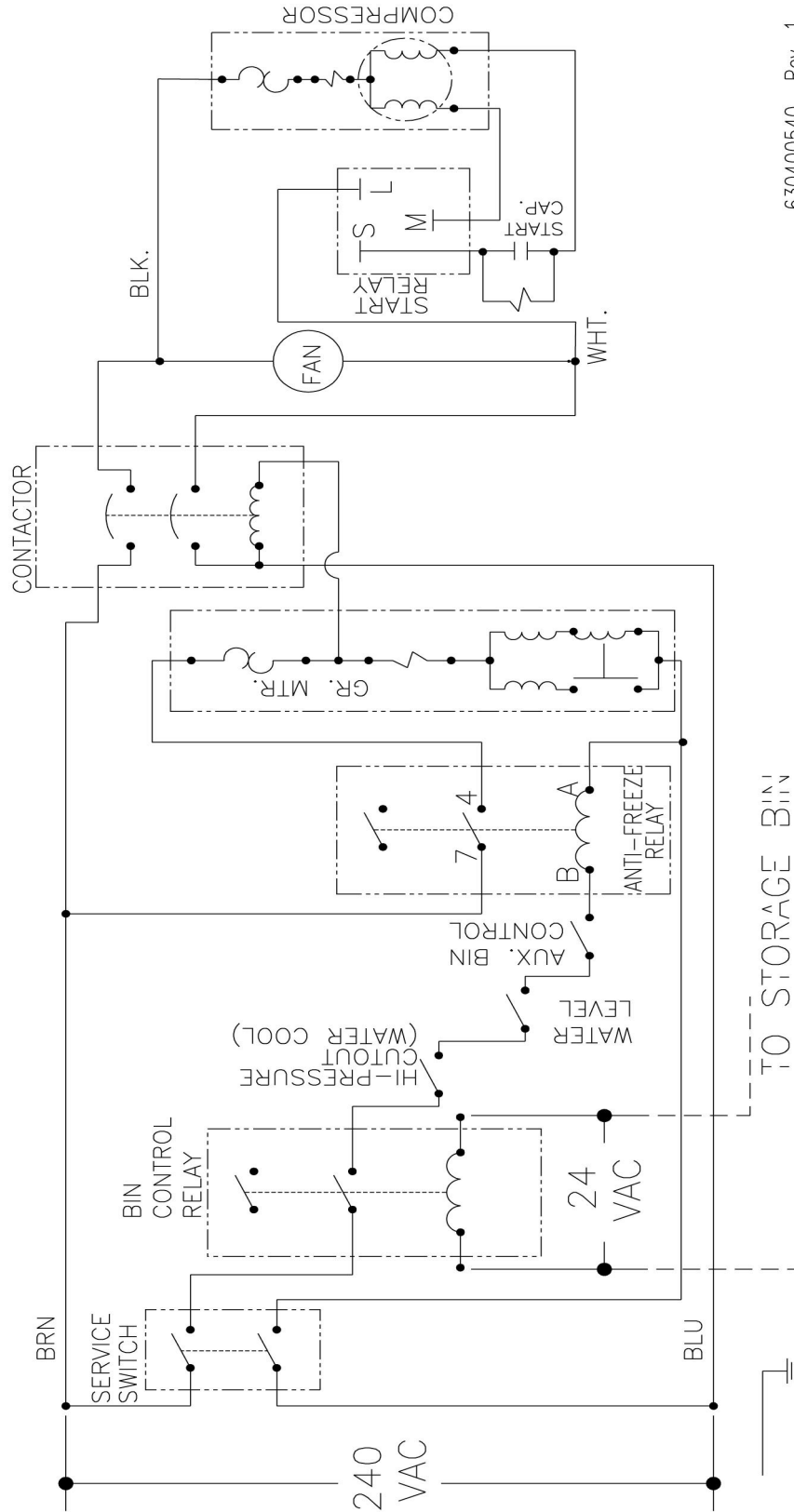

630400540 Rev. 1

Figure 14. Wiring Diagram 240V

**TROUBLESHOOTING CHART - ICEMAKER NOT OPERATING**

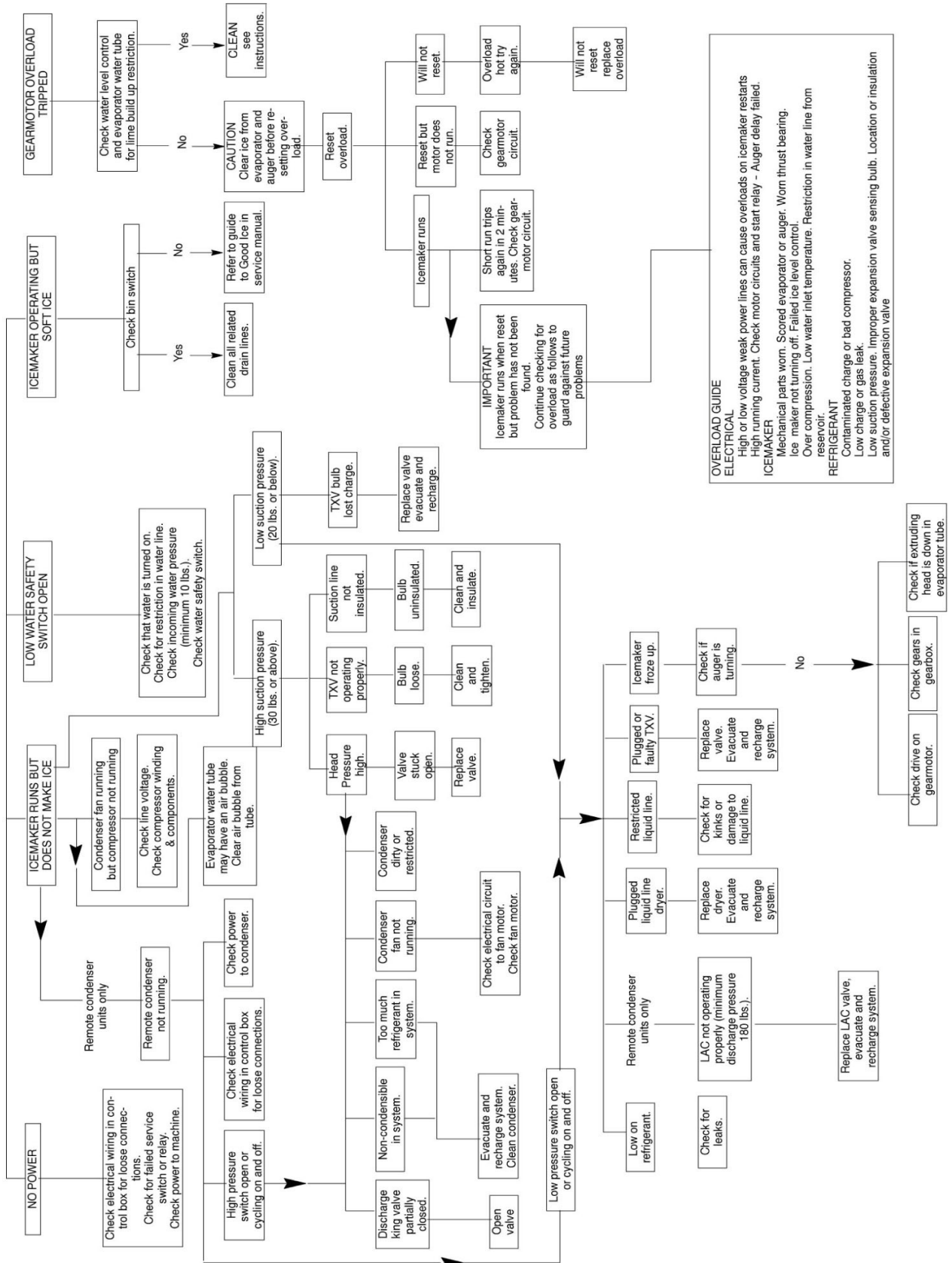



# TROUBLESHOOTING

**IMPORTANT:** Only qualified personnel should service internal components or electrical wiring.

## TROUBLESHOOTING COMPRESSORS

| Trouble  | Probable Cause   | Remedy   |
|--|--|--|
| Basically the compressor problems can be narrowed down to three areas of checkout. |  |  |
| THE COMPRESSOR WILL NOT RUN  | <ul style="list-style-type: none"> <li>A. No voltage to the compressor terminals.</li> <li>B. Low voltage.</li> <li>C. Problems in the compressor electrical circuit.</li> </ul> | <ul style="list-style-type: none"> <li>A. Check circuit.</li> <li>B. Below 90% of nameplate rated voltage.</li> <li>C. See electrical checkout instructions.</li> </ul>  |
| THE COMPRESSOR STARTS BUT TRIPS REPEATEDLY ON THE OVERLOAD PROTECTOR               | <ul style="list-style-type: none"> <li>A.</li> <li>B.</li> <li>C. Voltage.</li> <li>D. High compressor amperage draw.</li> </ul>   | <ul style="list-style-type: none"> <li>A. Check for proper fan operation and clean condenser.</li> <li>B. Check the compressor suction and discharge pressures.</li> <li>C. Voltage should be within 10% of the rated nameplate voltage.</li> <li>D. It should never exceed 120% of the rated nameplate amperage. See electrical checkout instructions.</li> </ul> |
| THE COMPRESSOR RUNS BUT WILL NOT REFRIGERATE                                       | <ul style="list-style-type: none"> <li>A. Compressor not working</li> </ul>  | <ul style="list-style-type: none"> <li>A. Check the compressor suctions and discharge pressures. See chart on page 11.</li> </ul>  |

# PARTS LIST

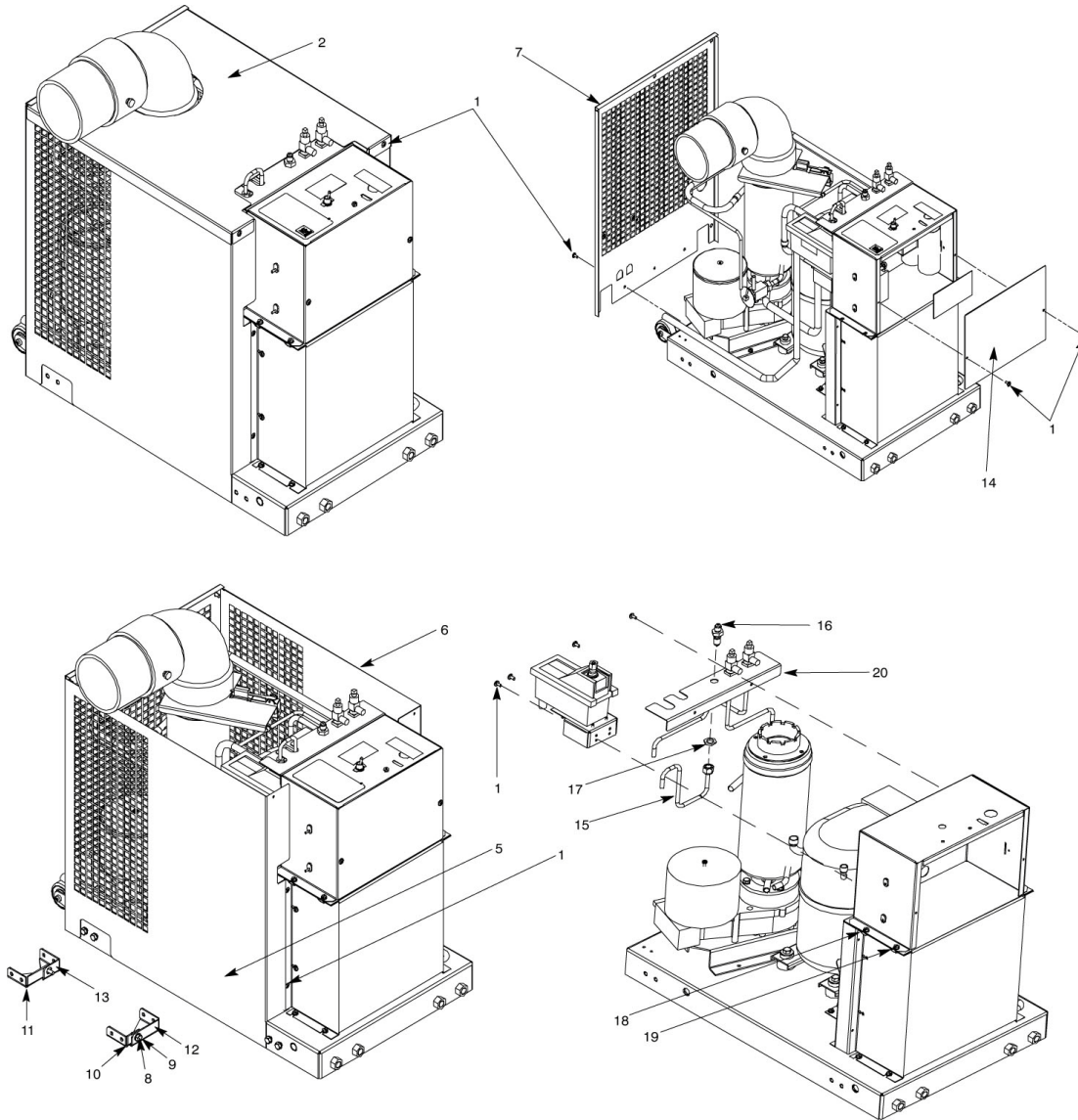
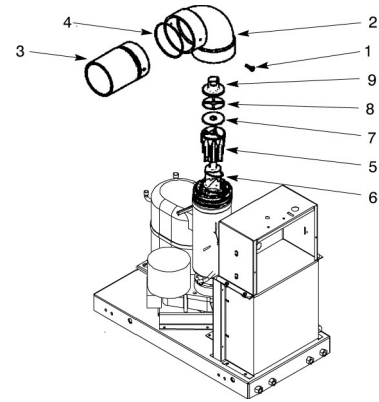

Figure 15. Cabinet Section Exploded View

| Item No. | Part No.  | Name   | Item No. | Part No.      | Name                       |
|----------|-----------|--|----------|---------------|----------------------------|
| 1        | 07578     | Thread Cutting Screw, Phil Truss Hd.No. 8--32 X 3/8--in long | 11       | 630000908     | Brkt Wld Asy Rear Bin      |
| 2        | 630000806 | Panel Top  | 12       | 630200868     | Brkt Chassis Alignment Fnt |
| 3        |           |  | 13       | 630200876     | Brkt Bin Alignment Rear    |
| 4        |           |  | 14       | 630200735     | Cover Elec Box             |
| 5        | 630000808 | Panel, Left--Hand  | 15       | 630250094     | Line Water Inlet           |
| 6        | 630000807 | Panel, Right--Hand   | 16       | 638008409     | Fitting Bulkhead           |
| 7        | 630201094 | Panel, Back  | 17       | 638007206--04 | Nut Jam 1/2--20            |
| 8        | 161176000 | Washer, Flat, .250 I.D.                                      | 18       | 638007276--01 | Nut 10A or Z Tinn          |
| 9        | 161179001 | Bolt MA 1/4--20 X 5/8--In Long                               | 19       | 638007972--01 | Screw Sm #10 X 3/4 HX      |
| 10       | 630000907 | Brkt Wld Asy Fnt Bin   | 20       | 630250091     | Service Valve Assy         |

| Item No. | Part No.      | Name                  |
|----------|---------------|-----------------------|
| 1        | 38220         | Machine Screw, 1/4-20 |
| 2        | 630000741     | Elbow, Ice Chute      |
| 3        | 630250106     | Tube, Ice Transfer    |
| 4        | 630900564     | O-Ring, 4.234 I.D.    |
| 5        | 630900608     | Head, Extruder        |
| 6        | 638090213     | Auger                 |
| 7        | 638090219     | Bearing, Nylon        |
| 8        | 638090220     | Bearing, Delrin       |
| 9        | 638090211-002 | Auger Nut             |



**Figure 16. Ice Chute Components**

| Item No. | Part No.     | Name   |
|----------|--------------|--|
| 1        | 161168017    | Machine Screw, Phil Pan Hd, No. 6-32 By 1/4-In. Long |
| 2        | 630900547    | Water Level Control                                  |
| 3        | 638004717    | Bracket, Water Level Control                         |
| 4        | 638006070    | Tube, .375 I.D.                                      |
| 5        | 638006070    | Tube, .375 I.D.                                      |
| 6        | 638008483-05 | Reed Switch Ass'y                                    |

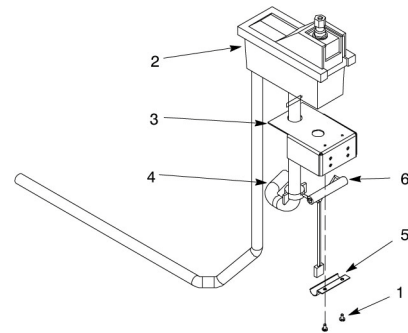

**Figure 17. Water Level Control Components.**

| Item No. | Part No.     | Name  |
|----------|--------------|---|
| 1        | 03611        | Snap Bushing  |
| 2        | 07578        | Thread Cutting Screw, Phil Truss Hd, No. 8-32 By 3/8-In. Long |
| 3        | 161165008    | Capacitor, Start 115V   |
|          | 25335        | Capacitor, Start 230V   |
| 4        | 161168005    | Thread Cutting Screw, Hex Hd, No. 8-32 By 1/2-In. Long        |
| 5        | 161192004    | Capacitor, Run  |
| 6        | 161998009    | Relay, Start Capacitor 115V                                   |
|          | 161998015    | Relay, Start Capacitor 230V                                   |
| 7        | 164083001    | Hex Nut, No. 6-32   |
| 8        | 630000599    | Wrap  |
| 9        | 630200166    | Strap, Capacitor  |
| 10       | 630900111    | Thread Cutting Screw, Phil Pan Hd, No. 8-32 By 3/4-In. Long   |
| 11       | 638003898    | Relay 115V  |
|          | 638010002    | Relay 230V  |
| 12       | 638004791    | Switch, Toggle  |
| 13       | 638030047    | Relay, 24V 10Amp  |
| 14       | 638090052    | Relay 115V  |
|          | 638090054    | Relay 230V  |
| 15       | 638007009-02 | Thread Cutting Screw, Phil Pan Hd, No. 6 By 3/8-In. Long      |

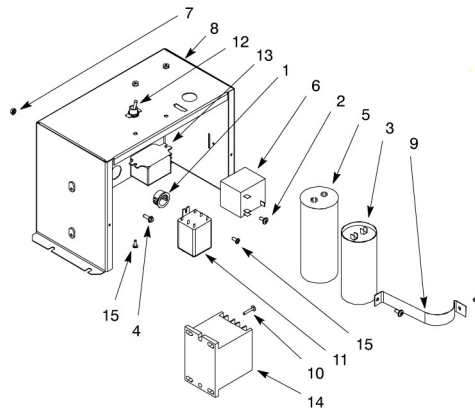

Figure 18. Electrical Box Components

| Item No. | Part No.     | Name   |
|----------|--------------|--|
|          |              | Compressor Components                            |
| 1        | 164154001    | Washer, Flat, >375 I.D.                          |
| 2        | 165596002    | Grommet  |
| 3        | 168770002    | Machine Screw, Hex Hd, 5/16-18 By 1 1/2-In. Long |
| 4        | 631500018    | Compressor Kit 115V                              |
|          | 631500018    | Compressor Kit 230V                              |
| 5        | 638007972-02 | Hex Washer Hd, No. 10 By 1/2-In. Long            |

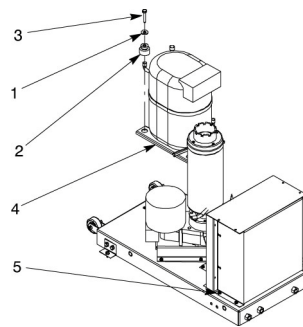

Figure 19. Compressor Components

| Item No. | Part No.      | Name   |
|----------|---------------|--|
| 1        | 161179001     | Machine Screw, Hex Hd, 1/2-20 By 5/8-In. Long              |
| 2        | 168833000     | Washer, Lock, .255 I.D.                                    |
| 3        | 168833002     | Washer   |
| 4        | 311462000     | Machine Screw, Hex Hd, 5/16-18 By 1/2-In. Long             |
| 5        | 630000651     | Evaporator Tube  |
| 6        | 30201088      | Bracket, Front End   |
| 7        | 630900128     | Thread Cutting Screw, SI Hex Hd, No. 10-32 By 3/8-In. Long |
| 8        | 638005406     | Shield, Motor  |
| 9        | 638031027     | O-Ring   |
| 10       | 638090051     | Seal, Shaft  |
| 11       | 638090053     | E-Ring   |
| 12       | 638090215     | Mount, Shaft Seal  |
| 13       | 638090216     | Seat, Shaft Seal   |
| 14       | 638007026-01  | Machine Screw, Phil Pan Hd, No. 8-32 By 3/8-In. Long       |
| 15       | 638007301-030 | Washer, Flat, 1.01 I.D.                                    |
| 16       | 638090001     | Gear Motor 115V  |
|          | 630900422     | Gear Motor 230V  |

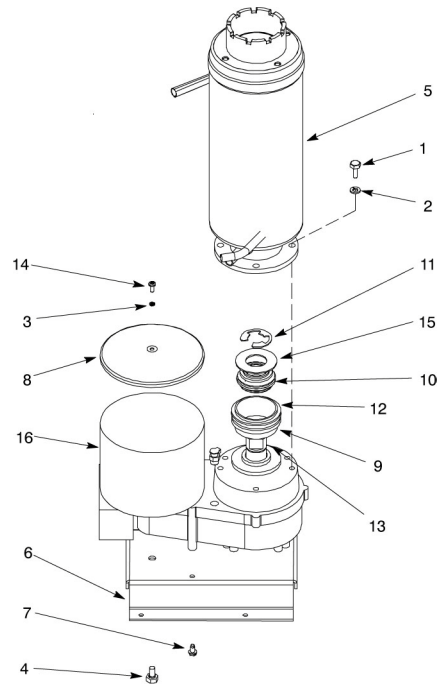

Figure 20. Front End Components

| Item No. | Part No.  | Name  |
|----------|-----------|---|
| 1        | 00258     | Speed Nut, 1/4-20                               |
| 2        | 03612     | Machine Screw, Hex Hd, No. 8-36 By 1/2-In. Long |
| 3        | 08822     | Cushion   |
| 4        | 638090009 | Bracket, Motor                                  |
| 5        | 638090236 | Motor 115V                                      |
|          | 638090233 | Motor 230V                                      |
| 6        | 638096723 | Fan Blade, Motor                                |

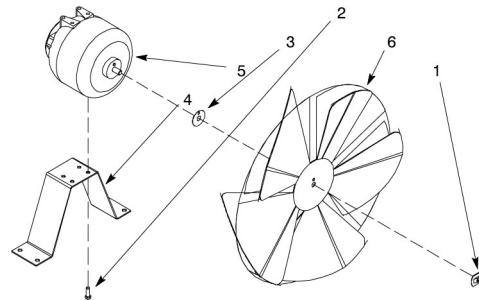

Figure 21. Condenser Motor Components

| Item No. | Part No.     | Name  |
|----------|--------------|---|
| 1        | 630200737    | Bracket   |
| 2        | 630900558    | Adaptor, Front End Ass'y                        |
| 3        | 630900559    | Gasket, Front End Ass'y                         |
| 4        | 630900572    | O-Ring, 4.1 I.D.                                |
| 5        | 630900635    | Machine Screw, Hex Hd, 1/4-20 By 1 3/4-In. Long |
| 6        | 638001662    | Insulator, Switch                               |
| 7        | 638003924    | Switch  |
| 8        | 638007009-10 | Screw, No. 6 By 1 1/4-In. Long                  |
| 9        | 638007264-02 | Tinnerman Nut                                   |
| 10       | 638007308-01 | Washer  |

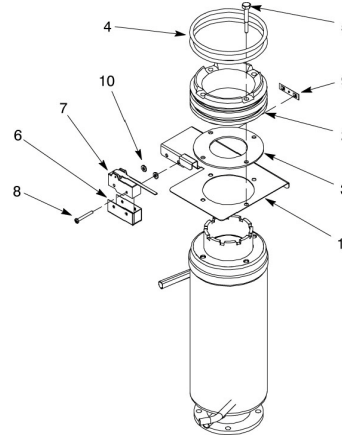

Figure 22. Evaporator Components

| Item No. | Part No.  | Name  |
|----------|-----------|---|
| 1        | 03535     | Sheet Metal Screw, SI Phil Hd, No. 10 By 1/4-In. Long |
| 2        | 630200730 | Shroud  |
| 3        | 638036273 | Condenser   |

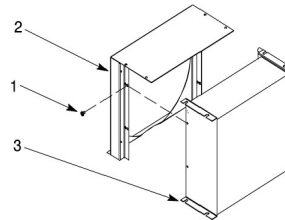

Figure 23. Condenser Components

| Item No. | Part No.  | Name                           |
|----------|-----------|--------------------------------|
| 1        | 630000801 | Chassis                        |
| 2        | 630000670 | Rod, Threaded, 5-In. Long      |
| 3        | 630000671 | Rod, Threaded, 21 1/2-In. Long |
| 4        | 630201097 | Rod                            |
| 5        | 638092019 | E-Ring                         |

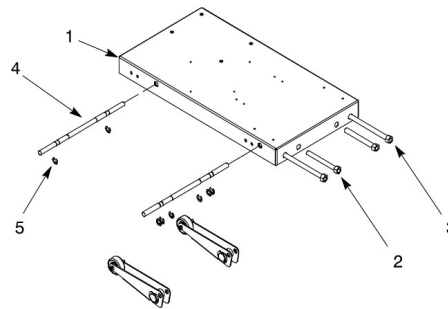

Figure 24. Base Components

| Item No. | Part No.  | Name    |
|----------|-----------|---------|
| 1        | 630000680 | Bracket |
| 2        | 630200872 | Rod     |
| 3        | 630900629 | Wheel   |
| 4        | 630900630 | Screw   |
| 5        | 638090053 | E-Ring  |

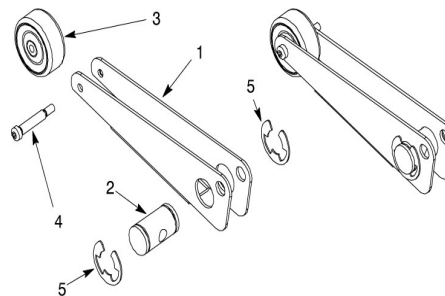

Figure 25. Wheel Components



**IMI Cornelius Inc.**  
**[www.cornelius.com](http://www.cornelius.com)**