

JET SPRAY

TEAJET

OWNER'S MANUAL/PARTS LIST

Instant Liquid Iced Tea Dispenser

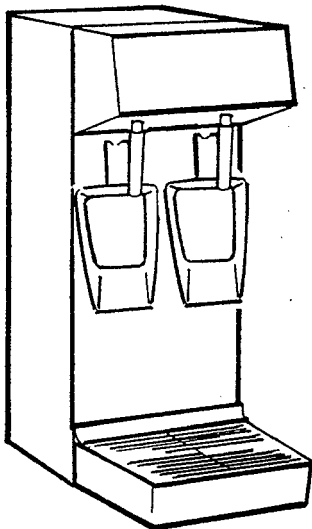

MODEL
LT12
LT12-W25

This manual applies to models of
Serial Number 320480 or higher.

Manufactured by Jet Spray Corporation
825 University Avenue, P.O. Box 8250, Norwood, MA 02062

January 1995
Printed in the USA

Document No. 13124
Revision No. 06

Your Standard of Excellence for Beverage Merchandising on Six Continents

TEAJET

MODEL LT12

INSTANT LIQUID ICED TEA DISPENSER

The Model LT12 is intended for commercial use. It is a compact, lightweight, counter-top, two flavor unit designed to dispense a mixture of tea concentrate (sweetened and/or unsweetened) and water simply by activating the proper push handle. The proper electrical outlet, two gallons of tea concentrate (sweetened and/or unsweetened), and a water source are all that are required to set dispenser into operation.

BRIEF DESCRIPTION OF HOW UNIT WORKS

A water line is connected to dual solenoid valves through a fitting located on the rear panel of unit. A one gallon container of tea concentrate (sweetened or unsweetened) is placed inside the unit through the removable front panel. The second one gallon of tea concentrate is placed in the rear of unit simply by lifting the cover in rear portion of unit. The product tubes are placed inside the gallon containers of tea concentrate, and run up to the mixing blocks. When one of the push handles is depressed it closes a switch, activating the proper solenoid valve, allowing water to pass through the mixing block. The pressure drop in the mixing valve allows concentrate to be siphoned from its container, mixed with water, and dispensed out the outlet tube.

A. INSTALLATION INSTRUCTIONS:

1. Place dispenser on a flat, sturdy surface accessible to a 115 volt 60Hz* outlet and a 30-125 psi water supply. It is recommended that a shutoff and an 80/100 mesh strainer be installed in the water line.
2. Do not plug in unit. Connect check valve supplied to inlet fitting at rear of unit. Use plastic seal gasket supplied.
3. Connect a 3/8" OD copper water line to the 3/8" flare connection located on the rear panel of the dispenser and to a 30-125 psi water supply. Water line should be long enough so that the unit can be moved for cleaning.
4. Remove drip tray and grille.
5. Remove front panel assembly from unit by lifting up and pulling out from the bottom. (See sketch)

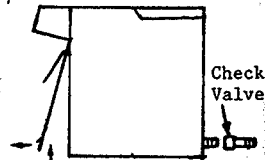

6. Remove cap and product tube assembly from inside unit. Place cap and product tube in a full gallon of concentrate. Slide concentrate inside the front of unit making sure that the plastic line from the product tube assembly is not crimped in any way.
7. Replace front panel assembly.
8. Replace drip tray and grille.

*EXPORT MODEL LT12-W25 REQUIRES A 220/240V 50Hz OUTLET

9. Place second gallon of concentrate in rear half of unit by lifting cover on the top of the rear half of unit.
10. Place the other cap and product tube in this gallon of concentrate. Close cover.
11. Plug power cord into 115 volt 60Hz* outlet.
12. Turn on power switch located in rear half of unit under the S.S. cover on the left hand side.
13. Depress push handles to prime unit, one at a time.
Note: Draw approximately 12 ozs. out of each side, or until product lines are full.
14. Unit is now set for operation.

B. RATIO CONTROL -- CONCENTRATE TO WATER

1. The ratio of concentrate to water is factory set for a 5 to 1 mix.
2. To adjust this ratio for a richer or weaker drink, use the 1/8" Allen wrench packed in the drip tray. Adjustments are made through holes located on the upper right hand and upper left hand side panels. Using the 1/8" Allen wrench turn the adjusting screw counterclockwise for a richer drink and clockwise for a weaker drink.

C. CLEANING UNIT

1. Drip tray, grille, and product tube assemblies may be washed in warm soapy water, such as Joy. Rinse thoroughly in potable water.
2. Clean the outside of the dispenser with a clean damp cloth and mild soap.

D. CLEANING MIXING VALVES

1. Fill a clean one gallon container with warm water (70°F - 100°F) and two ounces of cleaning solution, such as Joy.
2. Re-connect product tube assembly to mixing valve. Place other end of product tube assembly in cleaning solution.
3. Follow Installation Instructions #7 through #12, then activate each push handle for three to four minutes.
4. Replace cleaning solution with one gallon of potable water. Rinse valve assembly.
5. Repeat items 1 - 4 for cleaning the opposite mixing valve assembly.

E. SANITIZING DISPENSER

1. Using a clean one gallon container, mix 1/2 teaspoonful (100 parts/million) of approved powdered chlorine sanitizer (BASF Wyandotte Multi-Chlor or Equivalent Powder or Liquid Sanitizer) with four quarts of water. Depress push handle until all the sanitizing solution has been used.
2. Repeat for opposite mixing valve assembly.

*EXPORT MODEL LT12-W25 REQUIRES A 220/240V 50Hz OUTLET

LT12 GENERAL
SPECIFICATIONS

Electrical Spec.

Model Numbers:	LT12 (U.S.A.)	115V/60Hz	22.0 Watts	.2 Amps
	LT12-W16 (Export)	115V/60Hz	22.0 Watts	.2 Amps
	LT12-W25 (Export)	220/240V	22.0 Watts	.1 Amps
		50Hz		
Size:	7-1/2" wide x 20" deep x 18" high (19 cm x 51 cm x 46 cm)			
Cabinet:	Stainless Steel			
Drip Tray:	Removable			
Beverage Capacity:	Total - 12 gallons (46 liters) without refilling* (6 gallons in front & 6 gallons in rear) (23 liters) (23 liters)			
Dispensing Rate:	1.9 oz/second (.75 GPM flow washer)			
Net Weight:	14 lbs. (6.4 kg)			
Shipping Weight:	18 lbs. (8.16 kg)			
Carton Volume:	2.5 cubic feet (0.07 cm)			

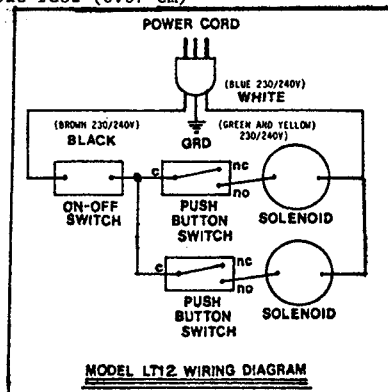

*Based on 5 to 1 ratio.

We reserve the right to make changes in design and/or engineering without notice.



IMI CORNELIUS INC.
One Cornelius Place
Anoka, MN. 55303-6234
Telephone 1-800-238-3600
Facsimile 1-800-258-0255

www.cornelius.com

ILLUSTRATED PARTS LIST

LT-12 COLD BEVERAGE DISPENSER

MODEL NO.

A3115

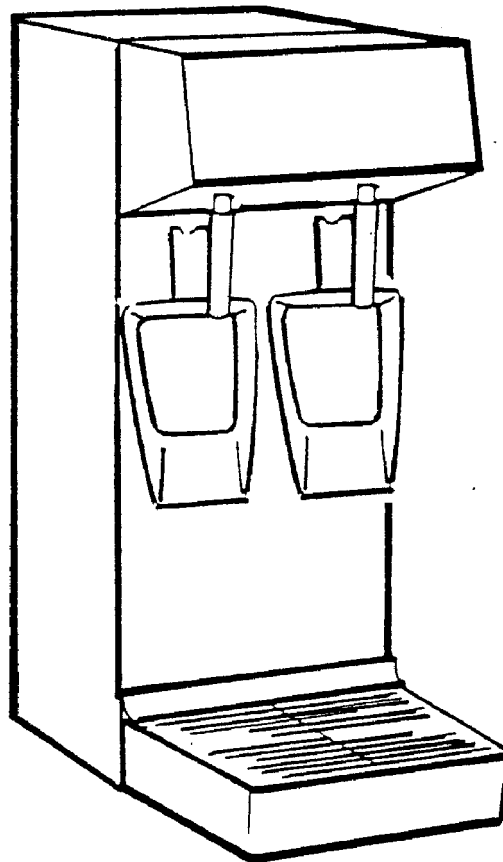



IMI CORNELIUS INC.
One Cornelius Place
Anoka, MN. 55303-6234
Telephone 1-800-238-3600
Facsimile 1-800-258-0255

www.cornelius.com

ILLUSTRATED PARTS LIST

LT-12 COLD BEVERAGE DISPENSER

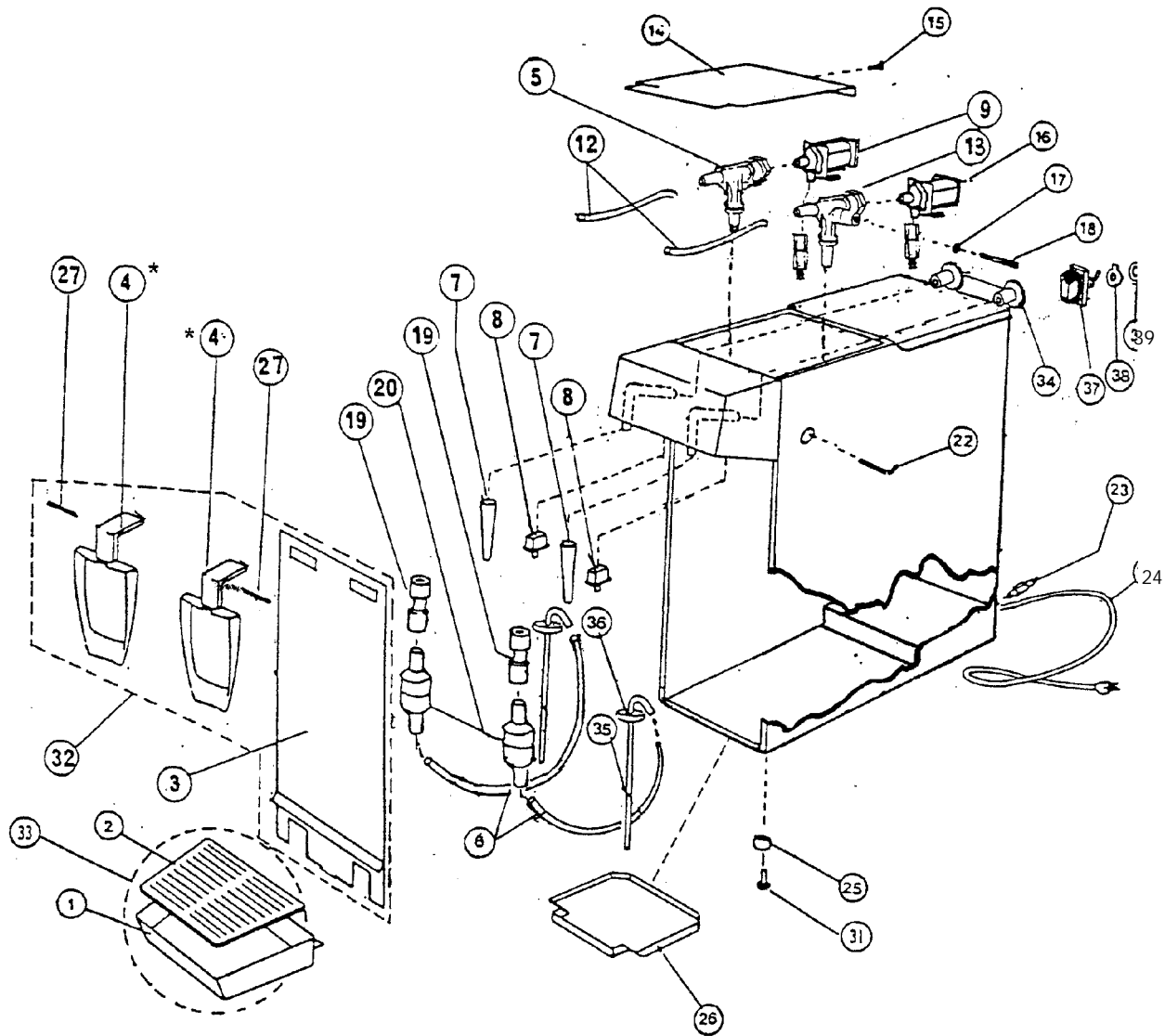

FIGURE 1. GENERAL ASSEMBLY



IMI CORNELIUS INC.
 One Cornelius Place
 Anoka, MN. 55303-6234
 Telephone 1-800-238-3600
 Facsimile 1-800-258-0255

www.cornelius.com

ILLUSTRATED PARTS LIST

LT-12 COLD BEVERAGE DISPENSER

Item No.	Part No.	Name
1	18805001	Drip Tray (Serial No. 320480 and Above)
	A1500	Drip Tray (Serial No. 320479 and Below)
2	18805002	Cup Rest (Serial No. 320480 and Above)
3	18787	Panel, Front (Serial No. 320480 and Above)
	S9436	Panel, Front (Serial No. 320479 and Below; No longer Available)
4	A3507	Push Handle (Serial No. 320480 and Above)
	A1506	Push Handle (Serial No. 320479 and Below)
5	A2333	Block Mixing Left Side
6	A1365	Tube Protector
7	A1340	Spout Extension
8	S8214	Switch Wtr Push Btn
9	S9437	Solenoid Valve Asy, Left Side
10		Item Not Used
11		Item Not Used
12	R6332	Tubg Silencer .250 I.D. (Sold by the Foot)
13	A1909	Block Mixing
14	S9178	Cover Top Panel
15	A1386	Screw Panel (Pack of 4)
16	A1339	Solenoid Valve Asy
17	S3746	Ring (Pack of 12)
18	S5624	Screw and O-Ring Adjust

Item No.	Part No.	Name
19	A2161	Conn Check Valve Union
20	A2171	Valve Chk Inline
21		Item Not Used
22	S4159	Tool Wrench Allen
23	A3781	ValveChk Single
24	S1249	Cord Serv
25	S6778	Foot
26	A1360	Drip Tray
27	A1505	Pin Cotter
28		Item Not Used
29		Item Not Used
30		Item Not Used
31	S6410	Screw (Pack of 4)
32	A8806	Panel Ass'y, Front (Serial No. 320480 and Above; No Longer Available)
	A9435	Panel Ass'y, Front (Serial No. 320479 and Below; No Longer Available)
33	18805	Drip Tray Asy (Serial No. 320480 and Above; No Longer Available, order 18805001 and 18805002)
	A1503	Drip Tray Ass'y (Serial No. 320479 and Below)
34	A1900	Restrictotr Plug
35	S9526	Tube S.S.
36	A1834	Cap
37	S3004	Switch Toggle
38	S3837	Plate Switch
39	S1675	Nut Knurled Ring