



ILLUSTRATED PARTS LIST VISUAL MERCHANDISER

COR67VMST EXPLODED VIEW

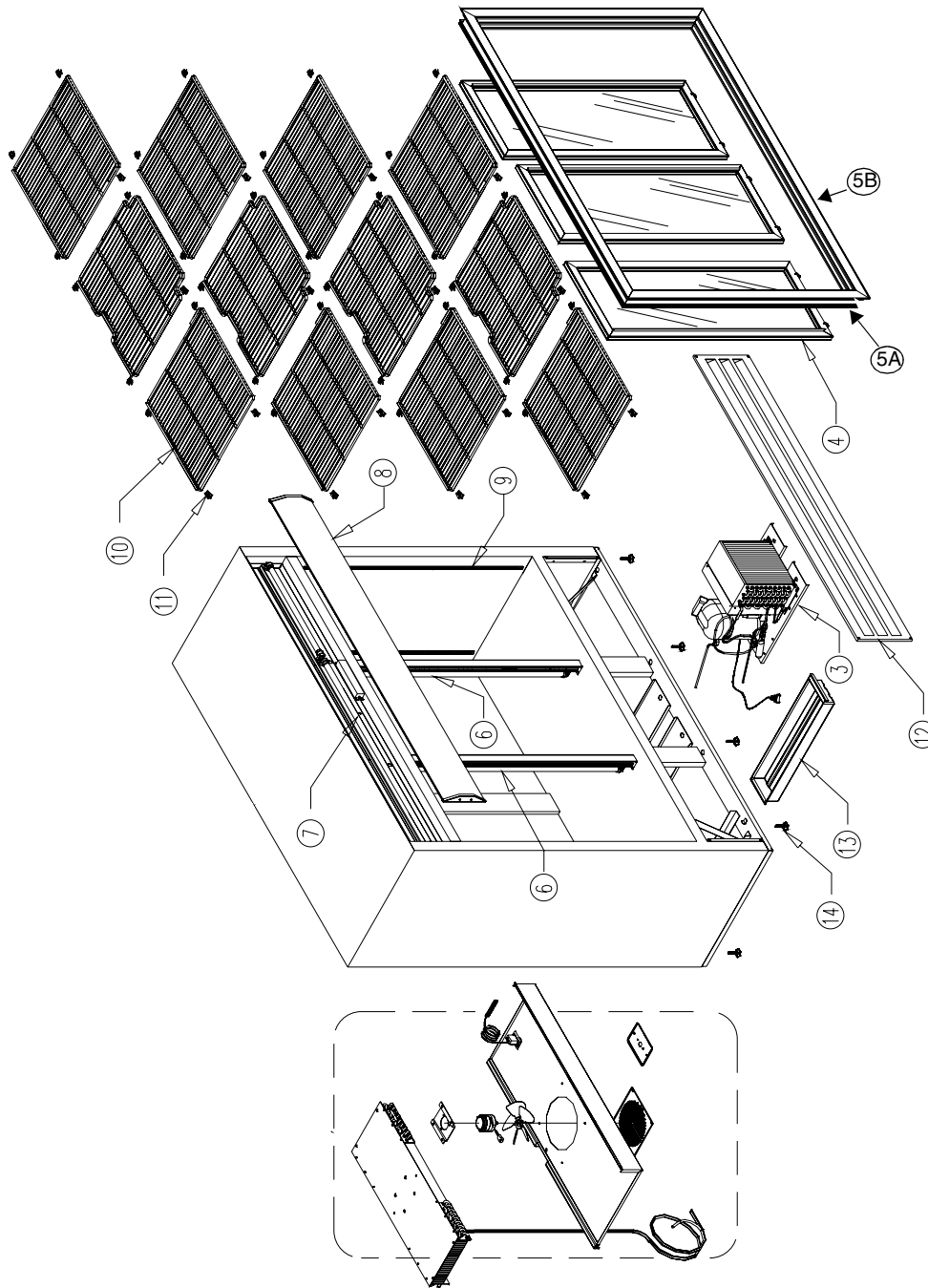

FIGURE 1



COR67VMST

EXPLODED VIEW

Item No.	Part No.	Name
3	FIGURE 3	Condensing unit 3/4 HP 115V/60Hz
4	FIGURE 4	Sliding door system
5A	1035050	Sliding door track Horiz
5B	1035044	Sliding door track Vert
6 and 7	FIGURE 5	Lighting systems
8	1035010	Header sign
9	1034919	Pilaster 48"

Item No.	Part No.	Name
10	1035014	Right flat shelf
	1035016	Middle flat shelf
	1035015	Left flat shelf
11	1033450	Shelf clips
12	1035017	Front grill
13	1035039	Water pan
14	1033235	Leveling legs



COR67VMST

REFRIGERATION SYSTEM

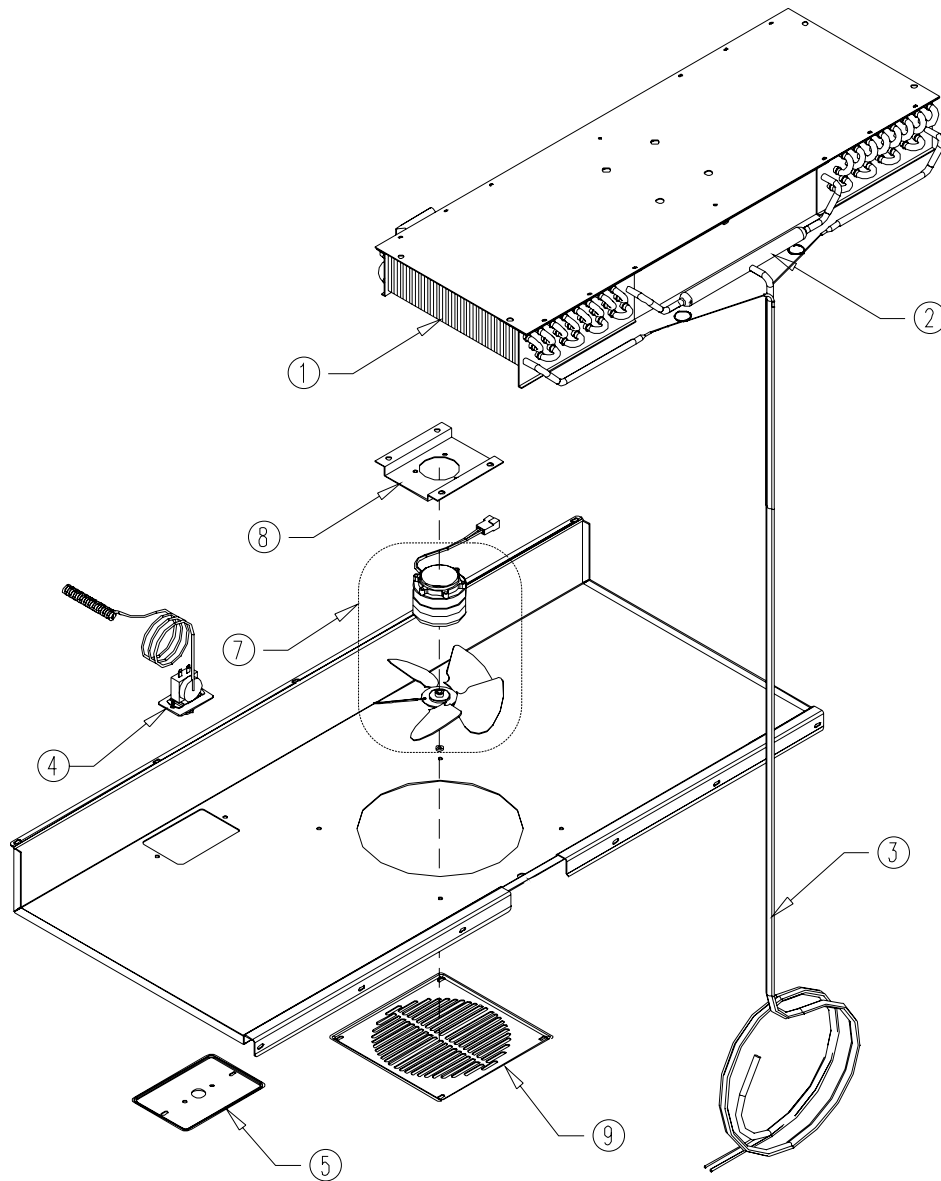

FIGURE 2

Item No.	Part No.	Name
1	1034943	Evaporator
2	1034924	Accumulator
3	1035393	Heat exchanger
4	1034925	Thermostat
5	1037647	Thermostat bracket

Item No.	Part No.	Name
7	1034945	Fan motor and blade
8	1033245	Fan motor bracket
9	1035395	Fan guard

COR67VMST

CONDENSING UNIT ASSEMBLY AND ITS COMPONENTS

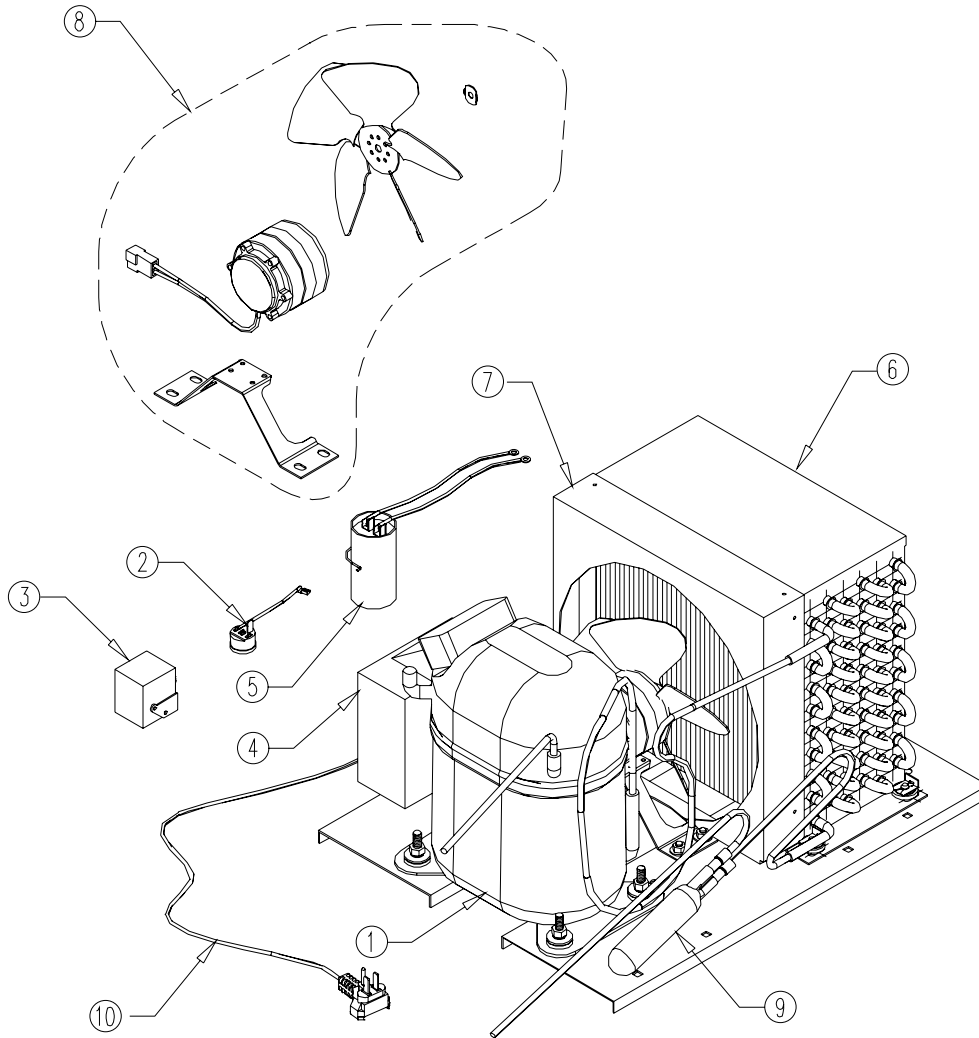

FIGURE 3

Item No.	Part No.	Name
1	1034946	Compressor 3/4 HP 115V/60H
2	1034947	Overload protector CST00AGSF
3	1034948	Relay 3ARR3B2L3
4	1034949	Electrical box

Item No.	Part No.	Name
5	1034950	Start capacitor 340-408 μ F
6	1034931	Condenser
7	1034932	Condenser shroud
8	1034933	Condenser fan motor and blade
9	1033253	Drier
10	1033255	Power cord

COR67VMST

SLIDING DOORS ASSEMBLY AND ITS COMPONENTS

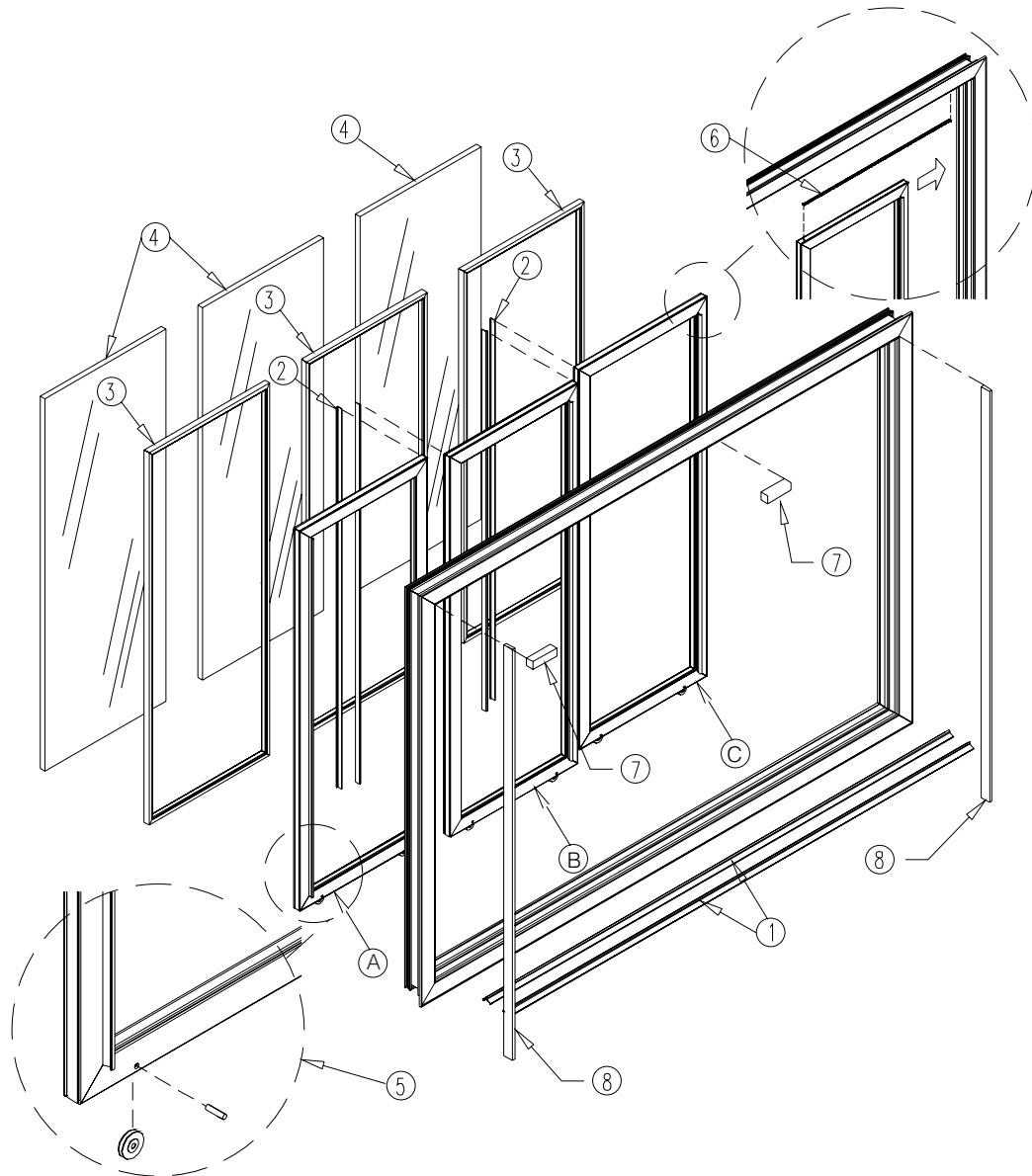

FIGURE 4

Item No.	Part No.	Name
A	1035008	Complete sliding door Left
B	1038440	Complete sliding door Center
C	1038439	Complete sliding door Right
1	1035052	Sliding door rail*
2	1035047	Sliding door seal
3	1035048	Sliding door gasket
4	1035009	Glass pane

Item No.	Part No.	Name
5	1035029	Sliding door roller
6	1035030	Sliding door spring
7	1035031	Sliding door bumper
8	1035049	Rubber gasket

*Each cabinet uses two sliding doors rail 70 1/2" long.

COR67VMST

INTERIOR AND SIGN LIGHTING SYSTEM ASSEMBLY AND ITS COMPONENTS

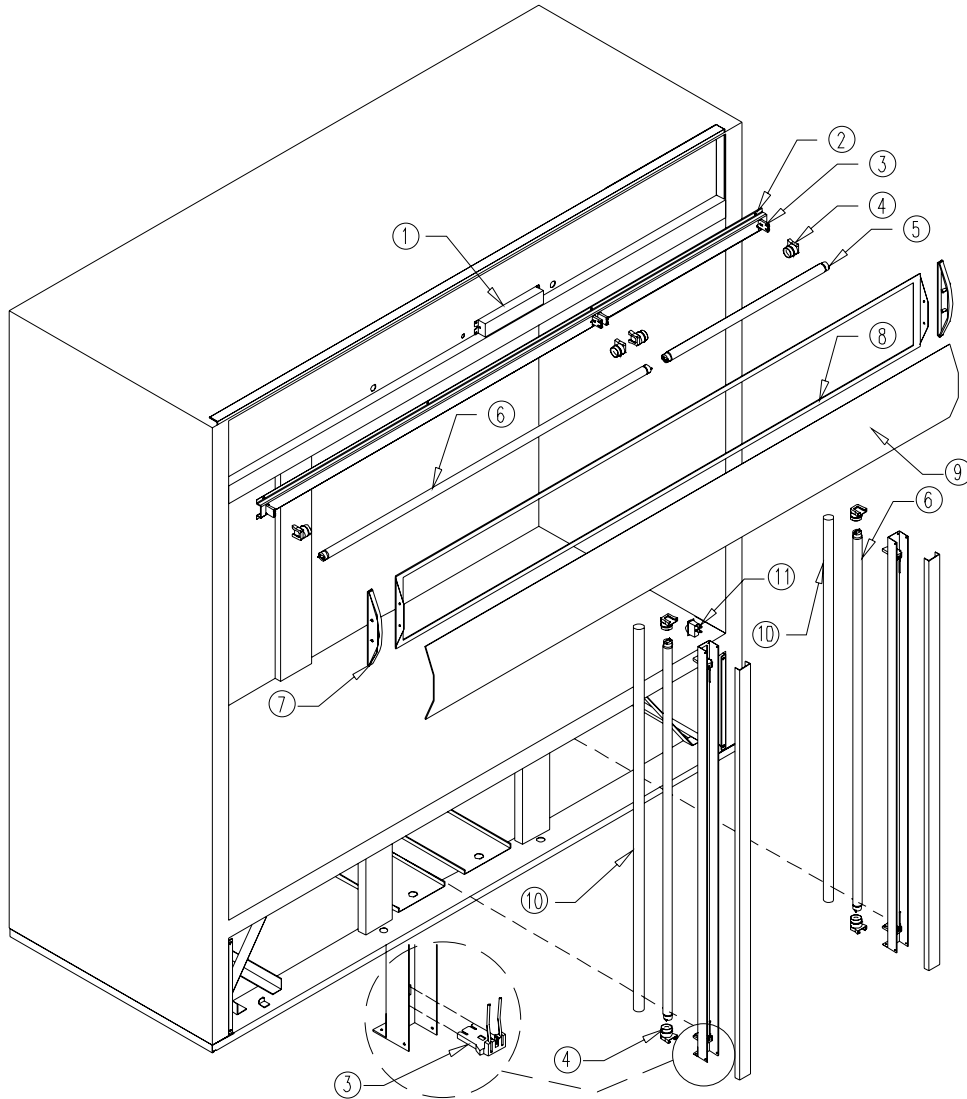

FIGURE 5

Item No.	Part No.	Name
1	1034955	Ballast QT4x32 T8/120 ISN-SC
2	1035011	Lamp
3	1033256	Lampholder
4	1033257	Lampholder cap
5	1035399	Fluorescent tube T8 FO17/865/XP/ECO

Item No.	Part No.	Name
6	1035400	Fluorescent tube T8 FO32/865/XP/ECO
7	1034896	Plastic sign ends
8	1035012	Sign frame
9	1035013	Acrylic sign
10	1034918	Light shield
11	1034886	Light switch