



ILLUSTRATED PARTS LIST VISUAL MERCHANDISER

COR35VMSD EXPLODED VIEW

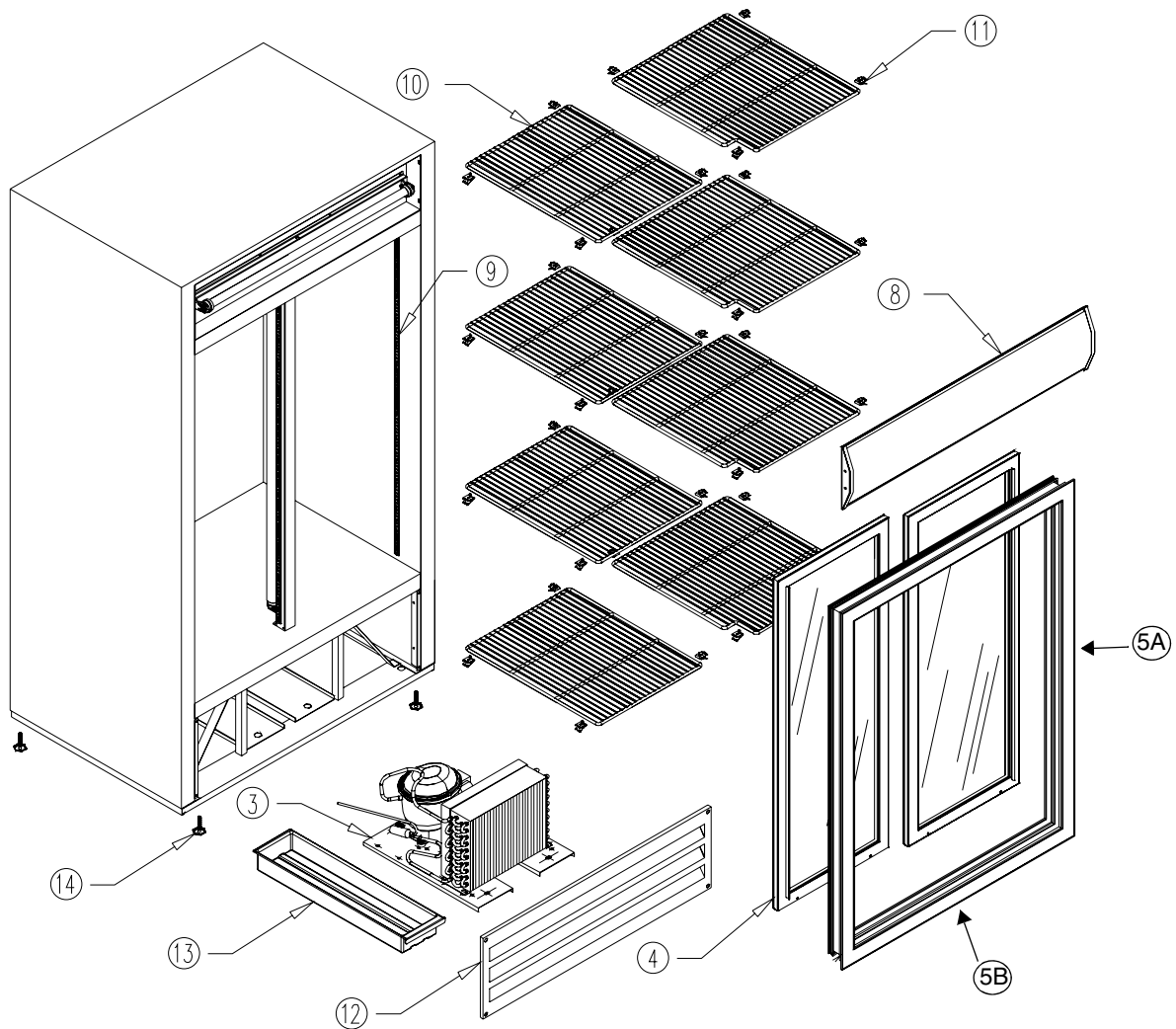

FIGURE 1

Item No.	Part No.	Name
3	FIGURE 3	Condensing unit 1/3 HP 115V/60Hz
4	FIGURE 4	Sliding door system
5A	1035044	Sliding door track Vert
5B	1035045	Sliding door track Horiz
8	1035032	Header sign
9	1034919	Pilaster 48"

Item No.	Part No.	Name
10	1035036	Right flat shelf
	1035037	Left flat shelf
11	1033450	Shelf clips
12	1035038	Front grill
13	1035039	Water pan
14	1033235	Leveling legs

COR35VMSD

REFRIGERATION SYSTEM

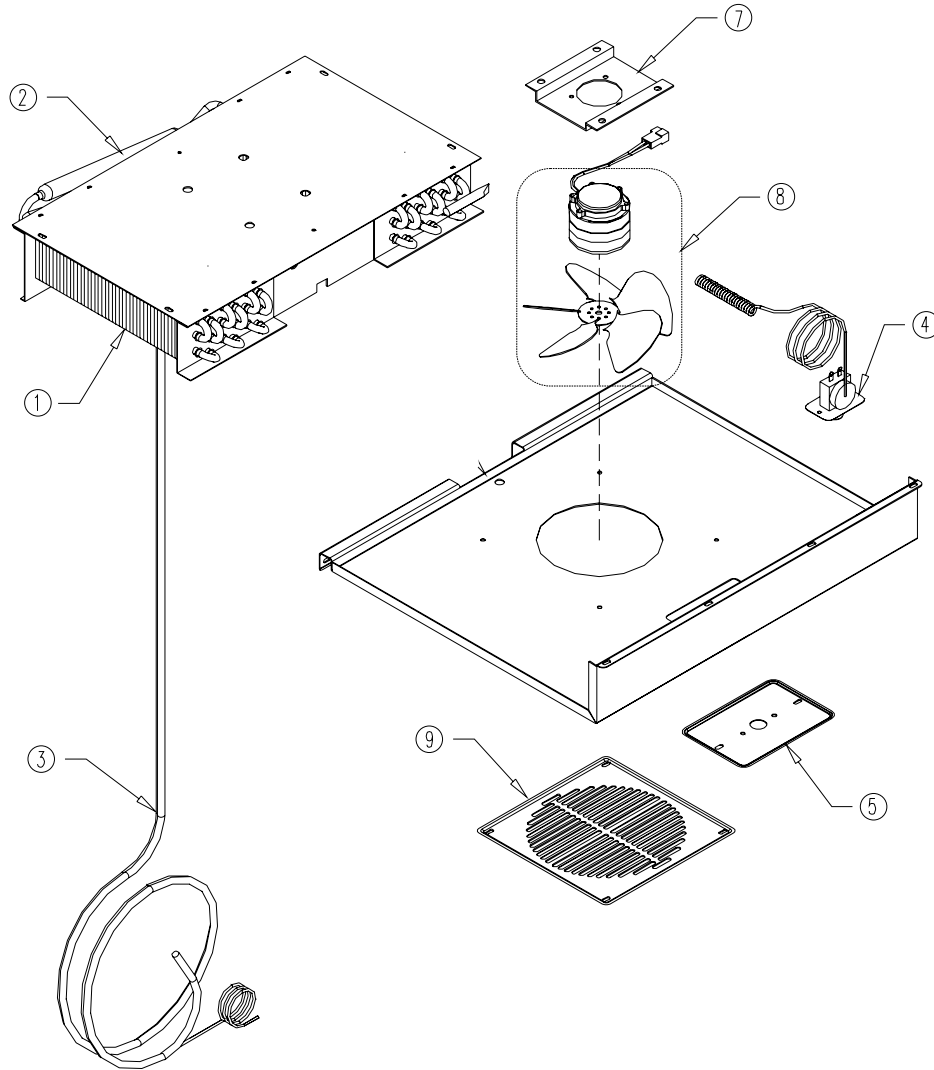

FIGURE 2

Item No.	Part No.	Name
1	1034923	Evaporator
2	1034924	Accumulator
3	1035392	Heat exchanger
4	1034925	Thermostat

Item No.	Part No.	Name
5	1037654	Thermostat bracket
7	1035042	Fan motor bracket
8	1034855	Fan motor and blade
9	1033247	Fan guard

COR35VMSD

CONDENSING UNIT ASSEMBLY AND ITS COMPONENTS

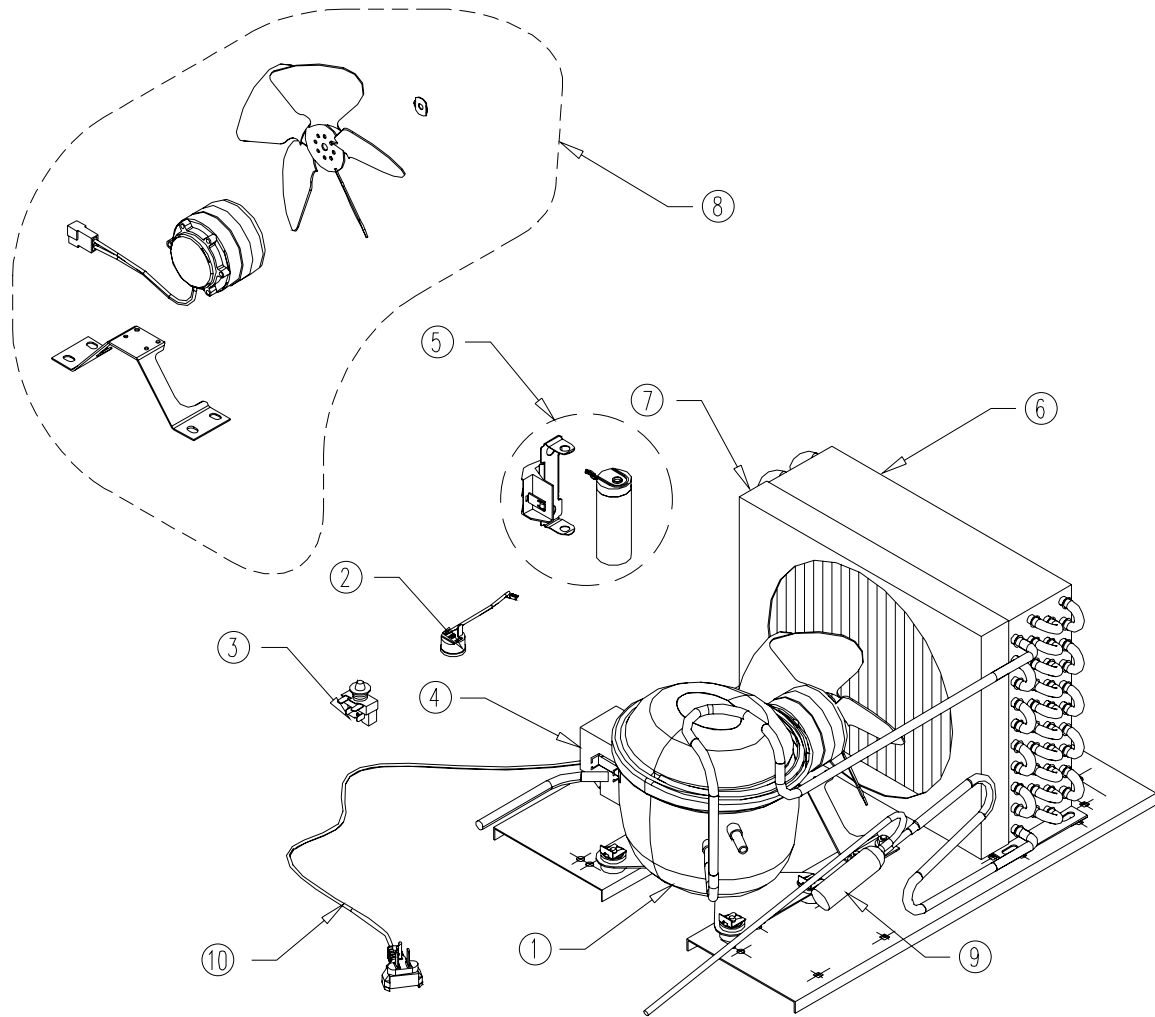

FIGURE 3

Item No.	Part No.	Name
1	1034904	Compressor 1/3 HP 115V/60H
2	1034906	Overload protector MRT26ADK-5590
3	1034908	Relay 213516051
4	1034909	Electrical box

Item No.	Part No.	Name
5	1034910	Start capacitor 378-454 μ F
6	1035025	Condenser
7	1035026	Condenser shroud
8	1034933	Condenser fan motor and blade
9	1033253	Drier
10	1033255	Power cord

COR35VMSD

SLIDING DOORS ASSEMBLY AND ITS COMPONENTS

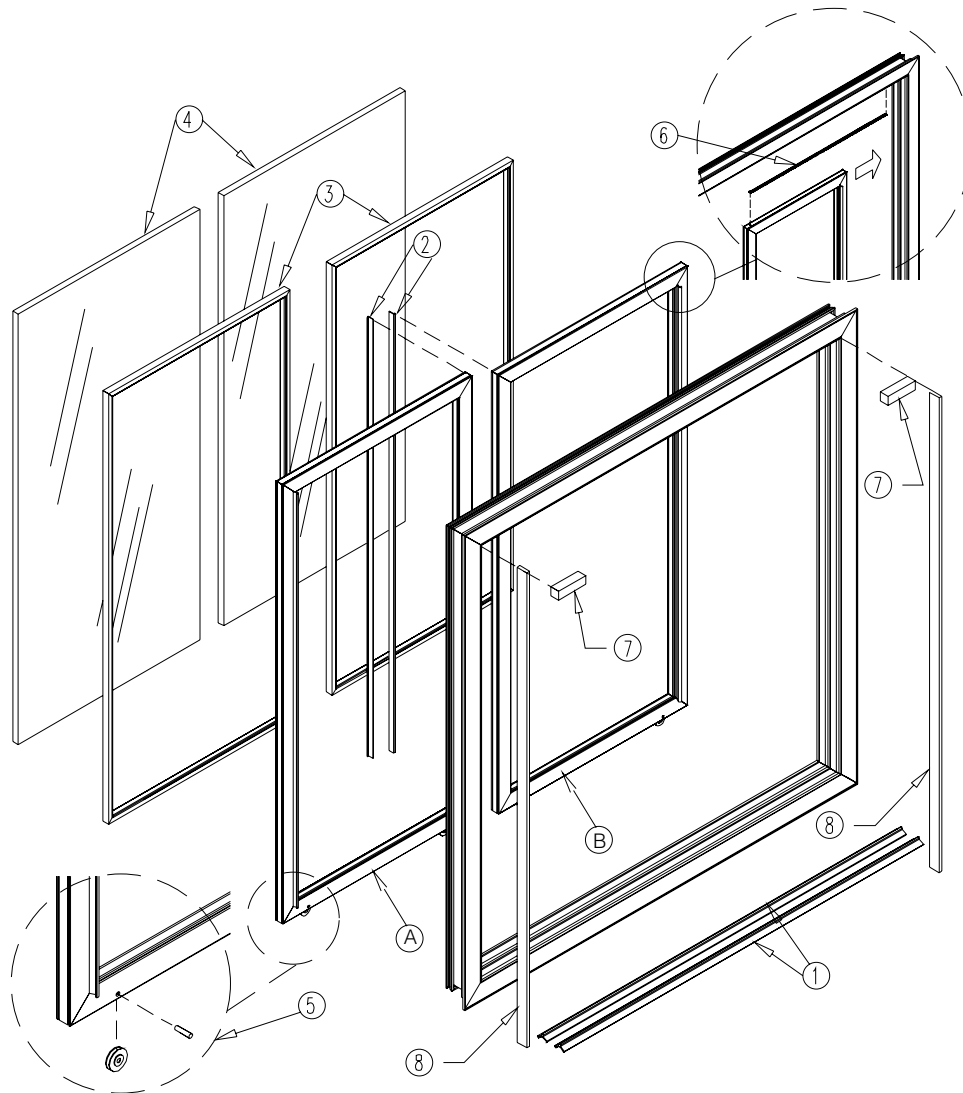

FIGURE 4

Item No.	Part No.	Name
A	1042082	Complete sliding door Left
B	1035027	Complete sliding door Right
1	1035046	Sliding doors rail *
2	1035047	Sliding door seal
3	1035048	Sliding door gasket
4	1035028	Glass pane

Item No.	Part No.	Name
5	1035029	Sliding door roller
6	1035030	Sliding door spring
7	1035031	Sliding door bumper
8	1035049	Rubber gasket

*Each cabinet uses two sliding door rails 37-1/4" long.



COR35VMSD

INTERIOR AND SIGN LIGHTING SYSTEM ASSEMBLY AND ITS COMPONENTS

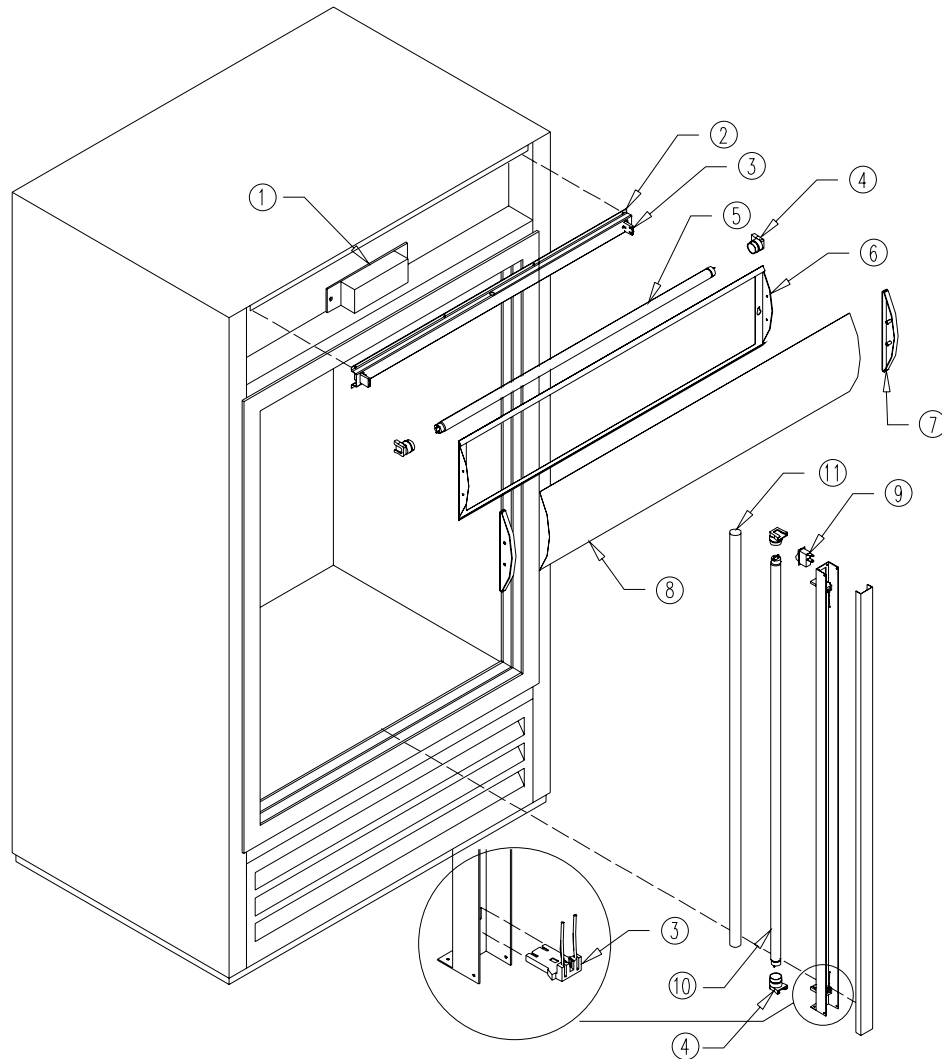

FIGURE 5

Item No.	Part No.	Name
1	1034893	Ballast QT2x32 T8/120
2	1035033	Lamp
3	1033256	Lampholder
4	1033257	Lampholder cap
5	1037655	Fluorescent tube T8 FO25/865/XP/ECO
6	1035034	Sign frame

Item No.	Part No.	Name
7	1034896	Plastic sign ends
8	1035035	Acrylic sign
9	1034886	Light switch
10	1035400	Fluorescent tube T8 FO32/865/XP/ECO
11	1034918	Light shield