

ICEU300 A/W Wiring Schematic From Serial Number 10041280011405

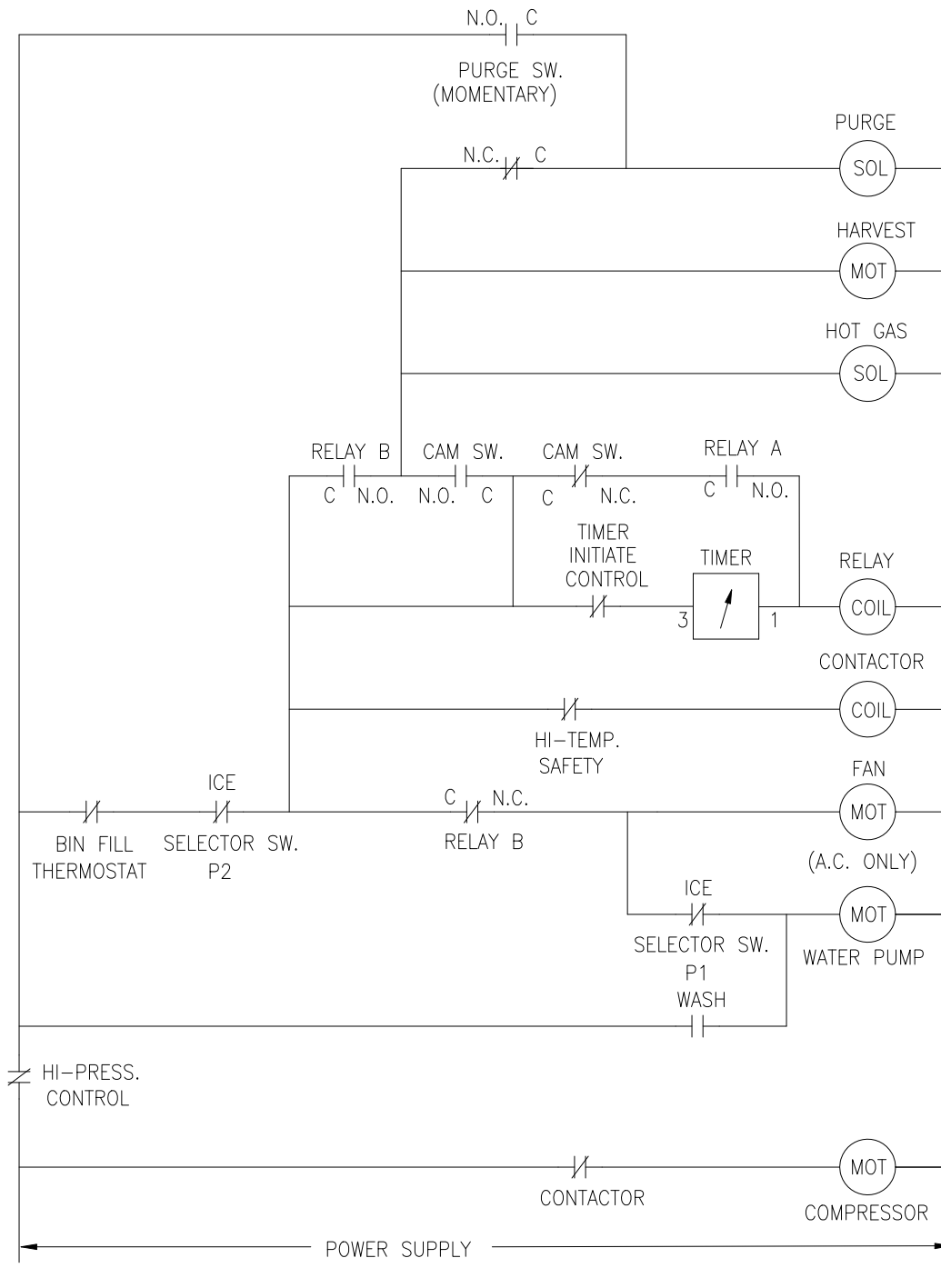

CONTROLS SHOWN DURING TIMED PORTION OF FREEZE CYCLE

9072089-01
REV B