



TAYHR

Operators Manual



MODEL:
HRF2-0

Hydra Rinse® Cleaning and Sanitizing System
for Soft Serve Ice Cream Machines

HYDRA RINSE®

CLEANS SIMPLE. SAFE. QUICK.

Complete for service reference information regarding your Hydra Rinse® product:

Model Number: _____

Serial Number: _____

Catalog Number: _____

Soft Serve Machine Model Number: _____

FCC Compliance Statement:

Note: This equipment has been tested and found to comply with the limits for a Class A digital device, pursuant to part 15 of the FCC Rules. These limits are designed to provide reasonable protection against harmful interference when the equipment is operated in a commercial environment. This equipment generates, uses, and can radiate radio frequency energy and, if not installed and used in accordance with the instruction manual, may cause harmful interference to radio communications. Operation of this equipment in a residential area is likely to cause harmful interference in which case the user will be required to correct the interference at his own expense.

ISED Compliance Statement:

This device contains licence-exempt transmitter(s)/receiver(s) that comply with Innovation, Science and Economic Development Canada's licence-exempt RSS(s). Operation is subject to the following two conditions:

1. This device may not cause interference.
2. This device must accept any interference, including interference that may cause undesired operation of the device.

L'émetteur/récepteur exempt de licence contenu dans le présent appareil est conforme aux CNR d'Innovation, Sciences et Développement économique Canada applicables aux appareils radio exempts de licence. L'exploitation est autorisée aux deux conditions suivantes :

1. L'appareil ne doit pas produire de brouillage;
2. L'appareil doit accepter tout brouillage radioélectrique subi, même si le brouillage est susceptible d'en compromettre le fonctionnement.

TAYHR

NSF listed as HRF2-0 under Hydra Rinse, LLC

Any unauthorized reproduction, disclosure, or distribution of copies by anyone unaffiliated with HYDRA RINSE, LLC relating to any portion of this work may be a violation of Copyright Law of the United States of America and other countries. Statutory Damages of up to \$150,000 (17 USC 504) could result for infringement, which could also lead to consequent civil and criminal penalties. All rights reserved.

Hydra Rinse, LLC 7870 Lehigh Crossing Suite 1, Victor New York 14564

Toll Free: 844-233-6349

Table of Contents

	Page
Section 1: Installation Guidelines	1
Section 2: Operator Introduction	2
Section 3: Safety	3
Section 4: Product Introduction	4
• The Hydra Rinse® Eco System	
Section 5: User Interface	5
• The RESET-CUPS-PROGRAM button functionality	
• The ONE TOUCH button functionality	
• The STATUS INDICATORS LEDs	
• The PLAY/PAUSE button functionality	
Section 6: LEXX™ Cups and Bottle Concentrate	7
• LEXX™ Liquid Sanitizer and Cleaner Concentrate	
Section 7: Registration of Token Tag	8
Section 8: Referenced Components	9
Section 9: Required Water and Drain Source	10
• Water Source	
• Drain Source	
Section 10: HRWAND128 Portable Wandstation	11
• General Information	
Section 11: Upgrade Components	12
Section 12: NSF Certified Hydra Rinse® Process	13
• 25 Step Reference Document	

Table of Contents

	Page
Section 13: NSF Certified Flavor Change Process	14
• 26 Step Reference Document	
Section 14: Details of the Hydra Rinse® Process	15
• Detailed Training Instructions for Sections 12 & 13	
Section 15: Troubleshooting Guide	39
• Table Defining Common Problems with Potential Cause and Solution	
Section 16: Pro-control Module LEDs.....	41
• Table Defining LED Process and Error Codes	
Section 17: Battery Installation/Replacement	43
Section 18: Online Resources/Support	44
Section 19: Warranty	45
Section 20: Appendix A	46
• LEXX™ pH Solution Measurement	
• LEXX™ Solution Total Acid Test	

Section 1: Installation Guidelines

The information provided is to ensure that your **TAYHR** meets factory tested Performance.

Requirements



No additional tools or fasteners are required for proper mounting to the soft serve machine; attaching features are all inclusive.

For the **WSF128-169 Portable Wandstation "HRWAND128"**: Depending on where the location of the "MOUNTING BRACKET" is installed e.g., concrete/drywall, etc., anchor bolts (**not included**) should be capable of supporting a minimum of 50 lbs. (Max screw diameter 3/16" actual size: 0.1875")

Care should be taken when installing your **TAYHR** to ensure proper performance and operation.

- Only **TAYHR** trained personnel should install and operate this device.
- Only Authorized **TAYHR** service personnel should make any necessary repairs

Note: *TAYHR is engineered to work exclusively with LEXX™ Liquid Sanitizer and Cleaner Concentrate.*

Protective Measures



Never submerge the Pro-control Module into any liquid. This product was manufactured and designed to meet IP65 standards:

- 6: Totally protected from dust contaminates.
- 5: Protected against low pressure jetting from water in all directions, limited ingress permitted.

Site Pre-requisite



Water supply must be >50 PSI, capable of flowing a minimum of 4.5 GPM, having a sanitary pH value of ~7.0-8.0.



We also recommend using a **Water Softener** to minimize hard water impact on the entire Hydra Rinse® Eco System.

Water Connection



Recommended outlet water temperature 110°F (43.3°C) but less than 120°F (48.9°C); Default: 112.5°F (44.7°C).

Note: No more than 120°F (48.9°C). Damage will occur to the Pro-control Module.

A backflow prevention device is required (**Not Included**) for the inlet water connection. Refer to applicable National, Federal, State, and local codes.

Specific State Requirements:

California (CA) Code: (Backflow Prevention, RPP)

Installed Backflow prevention device must meet or exceed specifications of Watts 9D Dual Check Valve(s) with intermediate Atmospheric Vent.

Section 2: Operator Introduction

The following Hydra Rinse® product: **TAYHR** has been carefully engineered and manufactured to give you consistent operation.

To the Operator

Careful maintenance and operation of this unit will ensure product quality and consistent performance. The **TAYHR** will require frequent cleaning of the unit itself. Please take care in understanding the outlined procedures in this manual.

Important Messages



For optimal results, follow the cleaning and sanitizing procedures for both Sections 12 and 13 without "**Interruption**".

Using Hydra Rinse® does not eliminate the present concerns associated with manual cleaning and sanitizing procedures:

Soft serve machines must never be placed in "**Auto Mode**" in place of "**Wash Mode**" for any type of cleaning and sanitizing process. When the freezing barrel(s) become filled with cleaning and/or sanitizing solution as a replacement for product mix, permeant damage can and most likely will occur to the freezing cylinders if the solution is allowed to freeze, causing the soft serve machine to become inoperable. So, when asked to place the machine into "**Wash Mode**" during the Hydra Rinse® process, be sure to never select "**Auto Mode**".

State Considerations:

(Included with HRWAND128 or LBUDDYSR): With every **TAYHR** is a LEXX™ pH Test Strip Kit. The test strip is used for measuring the acceptable range of pH for proper sanitization (strip should indicate less than 3.5pH).

For States requiring a total citric acid concentration (grams/Liter) semi-quantitative measurement (**Sold separately**). Use QUANTOFIX® Total acid part no. 91353 (Strip should indicate between 2.0-2.5 g/L)

Note: *Warranty is valid if authorized TAYHR parts are acquired from an authorized TAYHR Distributor/Reseller along with service work being performed by an authorized TAYHR service technician. Hydra Rinse® reserves any right to deny warranty claims on device or parts if unofficial TAYHR components were installed in the unit. This also applies to any modifications that fall out of the scope of factory recommendations, apparent abuse, or neglect.*

Note: *TAYHR is under continuous research and engineering; any improvements to our product will lead to information changes within this manual and are subject to change without notice (www.hydrarinse.com).*



Battery Disposal:

Hydra Rinse® is powered by 3 C Dry Cell Batteries

- **Do Not** place in fire or incinerator.
- **Do Not** dispose in refuse.
- **Do** remember to recycle in accordance with local regulations.



Section 3: Safety



Implementation with any one of our products requires a thorough understanding of factory recommendations; complete knowledge of this Operators Manual is recommended.

Important Message



Failures to adhere to the listed safety precautions may result in severe personal injury or even death. Personal, unauthorized service or repairs to this unit may result in inadvertent damages, and excessive service repair expense.

Visual Inspection



As a good practice, please take time to periodically inspect components for unforeseeable issues that may arise due to wear or damage (e.g., Water lines, supply hoses). Hoses can be an obstacle resulting in tripping and/or falling hazards that result in injury. Always work carefully around hoses avoiding injury to anyone within direct and/or indirect contact.

Water can wreak havoc with compromised systems, especially with unprotected surroundings like electrical receptacles that are unprotected by ground fault circuit interruption (GFCI). Worn out extension cords can lead to electrical shock when exposed to water.

Water/ Temperature



Do not operate the **TAYHR** with water temperatures above 120°F (48.9°C) is not recommended; burns will occur from over exposure.

Batteries



The Pro-control Module is designed for non-rechargeable batteries. Regular "C DRY CELL BATTERIES" can be exposed to some water for a short period of time: If this is the case, make sure batteries are completely dry before inserting into the Pro-control Module Battery Case.

Never change or remove the batteries when water is present. Find a dry, clean area when replacing batteries. Since the Pro-control Module is always around water, never substitute "DRY CELL BATTERIES" for any rechargeable batteries i.e., li-ion; use of Professional Alkaline Batteries is suggested.

If water enters the Pro-control Module Housing, discontinue usage immediately. Allow unit to air dry for 2 to 3 hours. If unit fails to operate correctly, replacement will be required; this failure is not covered under warranty.

WSF128-169 Portable Wandstation "HRWAND128"

Never directly point the wand at anyone, for any reason. Never insert the Wand Tip into any orifice of any food dispensing device while beaters are in motion and/or electrically powered food equipment that may allow access to electrical circuitry/ components. When possible, always power off equipment before servicing to avoid electrocution/damage to device.

Section 4: Product Introduction

The Hydra Rinse® Eco System is comprised of a plurality of Hydra Rinse® products designed to work exclusively with ProNatural Brands® naturally derived LEXX™ Liquid Sanitizer and Cleaner Concentrate (LEXX™). The Hydra Rinse® Eco System was designed for cleaning food dispensing equipment i.e., soft serve ice cream machines.

When you bring more components of The Hydra Rinse® Eco System into your cleaning process, the more time and money you begin to save while promoting a standardized cleaning solution for end users.

The Hydra Rinse® Eco System

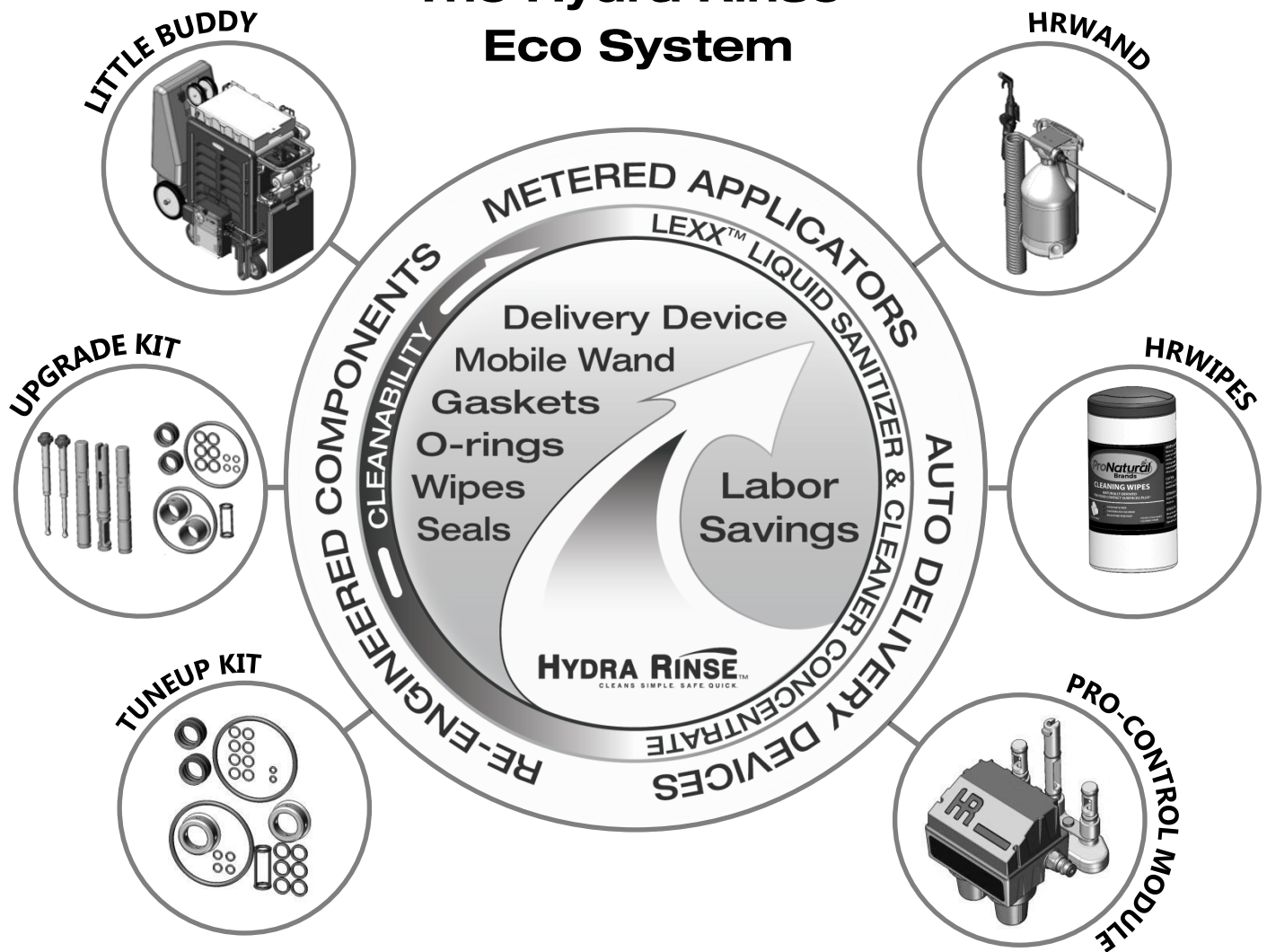

Ask your participating Distributor/Reseller for more information about Hydra Rinse® products and their applications.

Section 5: User Interface 1 of 2

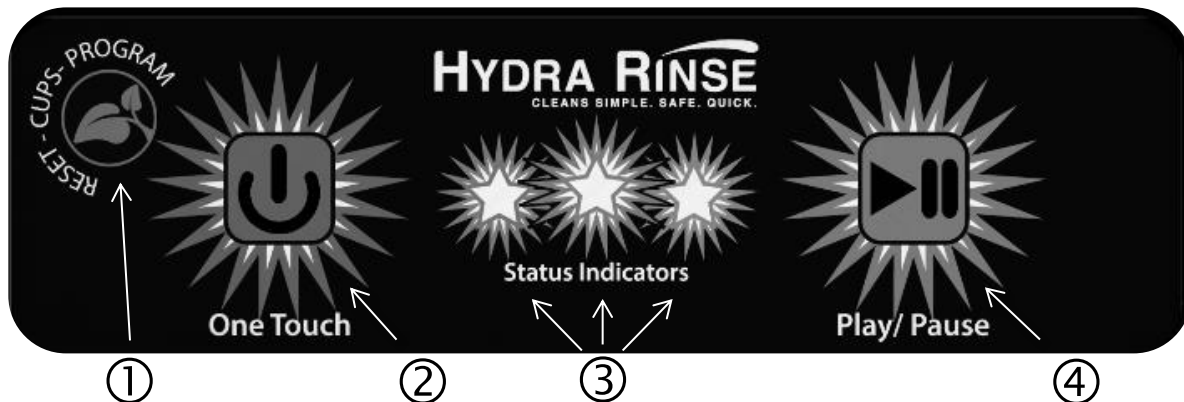

① The “RESET-CUPS-PROGRAM” button functionality:

- Reset the Pro-control Module processor/Read Firmware version
- Register cleaning/sanitizing cycles
- Read number of cleaning/sanitizing cycles available

② The “ONE TOUCH” button functionality:

- Initialize cleaning/sanitizing cycles
- Conclude cleaning/sanitizing cycle
- Self-clean mode when used simultaneously with the “PLAY/PAUSE” button

③ The “STATUS INDICATORS” LEDs:

- Power On/Cycle initiated
- Specific process codes
- Firmware Version
- Cycle paused
- Battery Low/Replacement Required
- Errors
- Number of registered cleaning/sanitizing cycles
- Cycle complete

④ The “PLAY/PAUSE” button functionality:

- Cancel initiated cleaning/sanitizing cycle
- Pause/Resume cleaning/sanitizing cycle
- Self-clean mode when used simultaneously with the “ONE TOUCH” button

Section 5: User Interface 2 of 2

An audible “BEEP” may also accompany many of the Status Indicator LED patterns. Audible sounds indicate to the end users that some kind of action may need to be taken e.g., place soft serve machine in “WASH/CLEAN MODE”, pause cycle for full teardown of the soft serve machine, batteries need to be replaced, some error needs to be resolved before operations can continue.

Section 16: “Pro-control Module LEDs” includes a table that breaks down the different patterns of the Status Indicator LEDs, along with descriptions and specific actions that may be required by the end user.

A unique function of the Status Indicators helps with registering/reading a “TOKEN TAG”. The Status Indicators will “BLINK” out the number of cleaning/sanitizing cycles stored inside the Pro-control Module when enabled.

For instance, the “GREEN LED” will represent the hundreds place, the “YELLOW LED” will represent the tens place and the “RED LED” will represent the ones place

e.g., 136 stored cycles are represented with 1 Green blink, 3 Yellow blinks and 6 Red blinks, indicating 136 available cycles are stored inside the unit.



Section 6: LEXX™ Cups and Bottle Concentrate

● “LEXX™ Liquid Sanitizer and Cleaner Concentrate” is the steam engine behind the Hydra Rinse® Process. Its naturally derived ingredient provides for incredible efficiency, it also has no negative impact on product mix or residual taste when used as directed. Not only is it tasteless, but it also doesn’t require rinsing after application. LEXX’s ability to remove and prevent milkstone will be evident with every application.

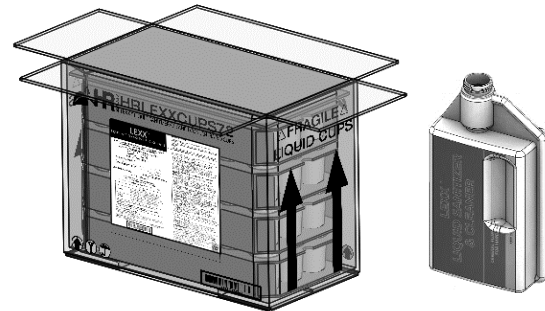

The Hydra Rinse® System requires different products of the same formulation: The “LEXX™ CUPS”, which come 72 per box provide for 36 automated cleaning cycles; one cup (2 fl. oz.) for cleaning and one cup (2 fl. oz.) for sanitizing. The “MEASURE & POUR BOTTLES” provides for 32 automated cleaning cycles: 2 fl. oz. for cleaning and 2 fl. oz. for sanitizing.

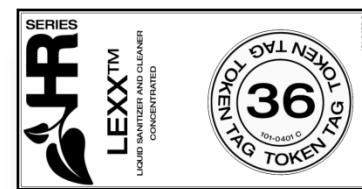

(Illustration of TOKEN TAG for LEXX™ cups)

The “LEXX™ CUPS” comes with a 36 cycle “TOKEN TAG”, and the Measure & pour bottles come with a 32 cycle “TOKEN TAG”. The token tag is registered with the Pro-control Module. This step ensures the Hydra Rinse® Process is using the specific sanitizer/cleaner it was created for; end user safety, Hydra Rinse® cleaning and sanitizing results depend on **LEXX™ Liquid Sanitizer and Cleaner Concentrate**.

● There is also the 1 Gallon version of **LEXX™ Liquid Sanitizer and Cleaner Concentrate**. The 1 Gallon container directly attaches to the HRWAND128.

The HRWAND128 will be used to perform many of the cleaning/sanitizing tasks within the Hydra Rinse® Process.



Section 7: Registration of Token Tag

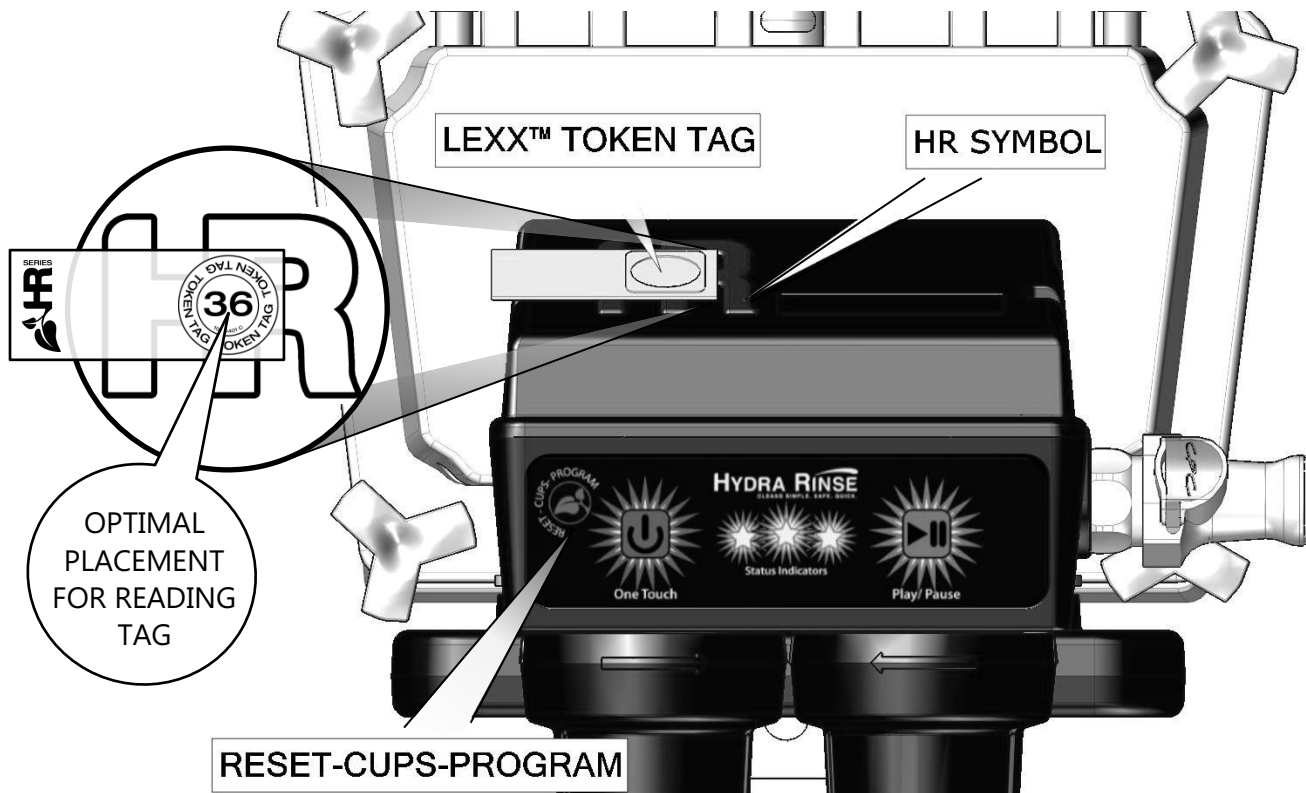

(For reading out number of available cycles, use an old/previous registered "TOKEN TAG"!)

Before the Pro-control Module can be put into operation, first install batteries (Section 17: Battery Replacement) followed by registration of the "TOKEN TAG". The "TOKEN TAG" can be found inside either box of "LEXX™ CUPS" or "LEXX™ MEASURE AND POUR"; more specifically it's directly attached to the LEXX™ Liquid Sanitizer and Cleaner Concentrate product insert card.

To register your new sanitizer/cleaner, simply hold the "TOKEN TAG" up against the "HR SYMBOL" located on the top cover of the Pro-control Module as illustrated; placing the portion of the Token Tag that contains the printed number of cycles up against the "HR SYMBOL" i.e., exactly in the center of the "HR SYMBOL" as illustrated.

While holding the "TOKEN TAG" in position, whether for registering or reading, press and then release the "RESET-CUPS-PROGRAM" button; the LEDs will begin to illuminate. Once the "TOKEN TAG" has been successfully registered a "BEEP" will be heard, followed by the "STATUS INDICATORS" blinking out the number of stored cycles within the Pro-control Module.

To conclude the "TOKEN TAG" registration process, once again press and then release the "RESET-CUPS-PROGRAM" button, but this time without the "TOKEN TAG" present. This will reset the Pro-control Module rendering it ready for use.

Section 8: Referenced Components

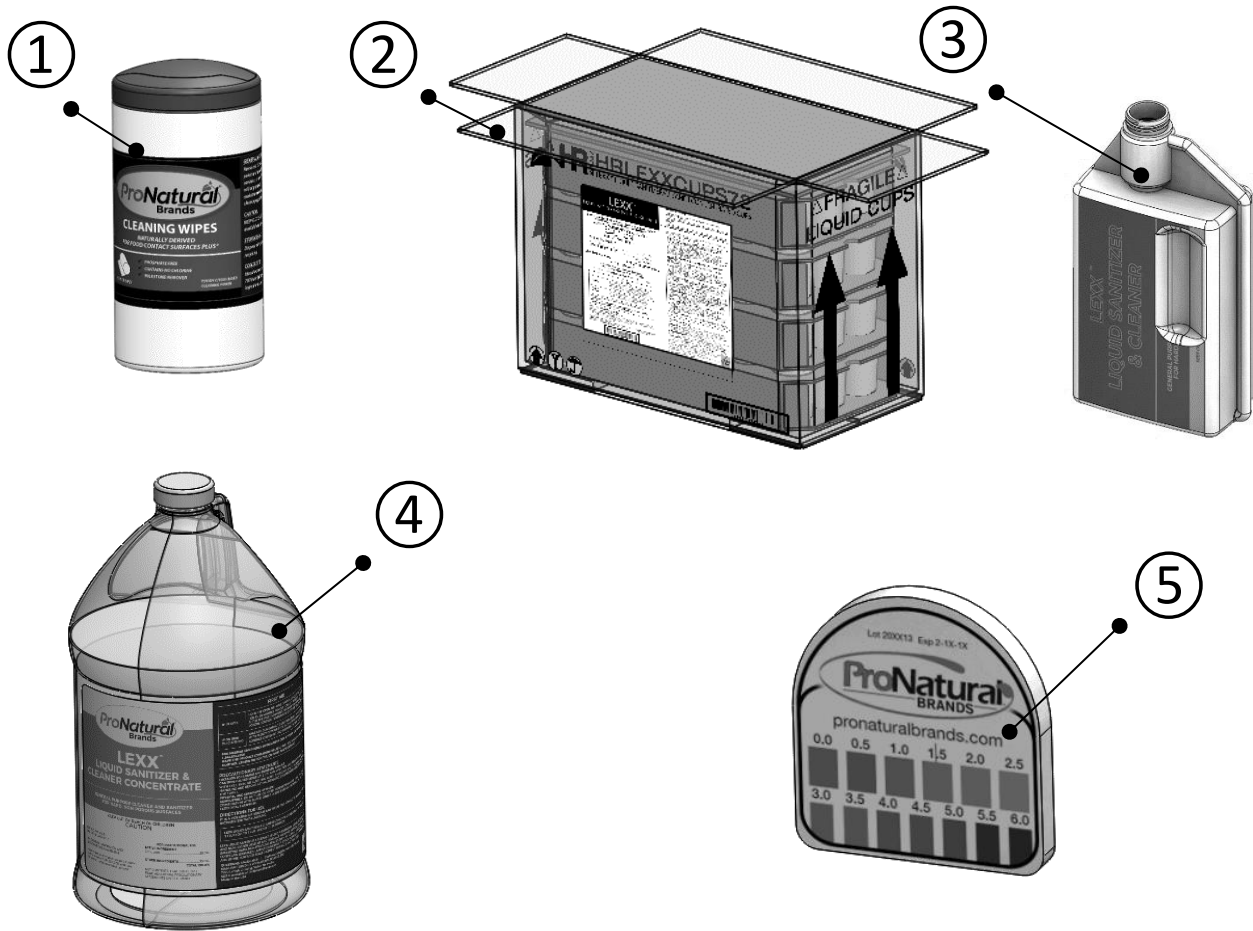

IMAGES FOR ILLUSTRATION ONLY

Item:	Description:
01	PRONATURAL® CLEANING WIPES
02	LEXX™ CUPS
03	LEXX™ MEASURE AND POUR LIQUID SANITIZER AND CLEANER CONCENTRATE BOTTLE
04	LEXX™ LIQUID SANITIZER AND CLEANER CONCENTRATE
05	LEXX™ pH TEST STRIPS (Included with Wand Products)

Section 9: Required Water and Drain Source

● WATER SOURCE:

It's important to have proper water pressure, water flow and water temperature (**Section 1: Installation Guidelines**). To ensure water temperature stays constant during the automated sequence, a "TEMPERATURE MIXING VALVE" (1) is recommended; must be installed in accordance with all applicable Local, State, National and Provincial Codes, Ordinances, Regulations and Laws.

Once the "FITTING, Y-GHT SPLITTER" item (17) is snug fitted to the "TEMPERATURE MIXING VALVE" item (1), continue to rotate the female GHT fitting counterclockwise for an additional 90-110° to insure a good tight fit. Repeat the same process for installing both the "25 FOOT POLYURETHANE 3/8" O.D. WATER SUPPLY ASSEMBLY" item (16) and for the combined "5 FOOT HOSE ASSEMBLY/EXTENDED WATER SUPPLY HOSE" item (15).

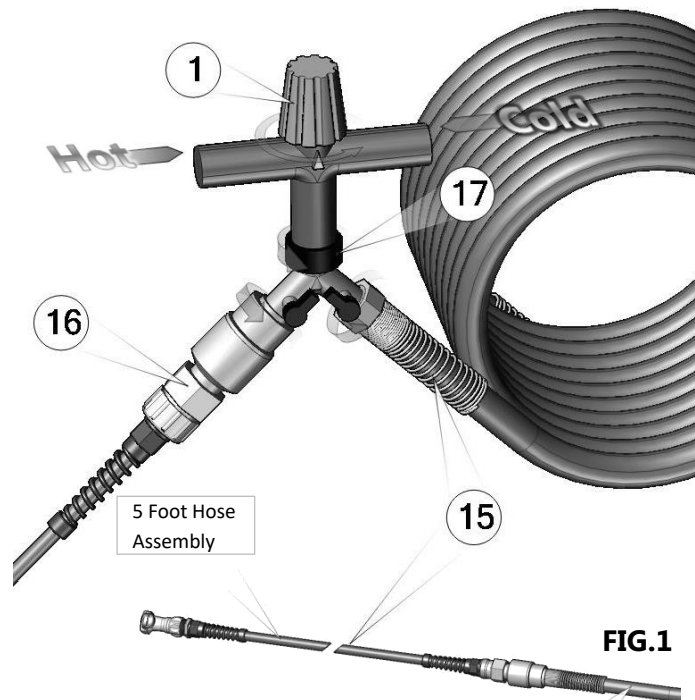

● DRAIN SOURCE:

There are three approved methods for waste discharge that flows from the "25' BYPASS SYSTEM DRAIN HOSE", which extends from the "BYPASS SYSTEM".

Unlike discharging waste through the "FREEZER DOOR" as in manual operations, the automated sequence of the Hydra Rinse® Process manages waste by removing it up through the food product mix inlet hole(s), completely opposite of traditional methods.

The uses of a Sink, Drain Inlet, or a NSF approved floor drain e.g., 1- 1/2" above drain gate, are all valid options for the waste discharge.

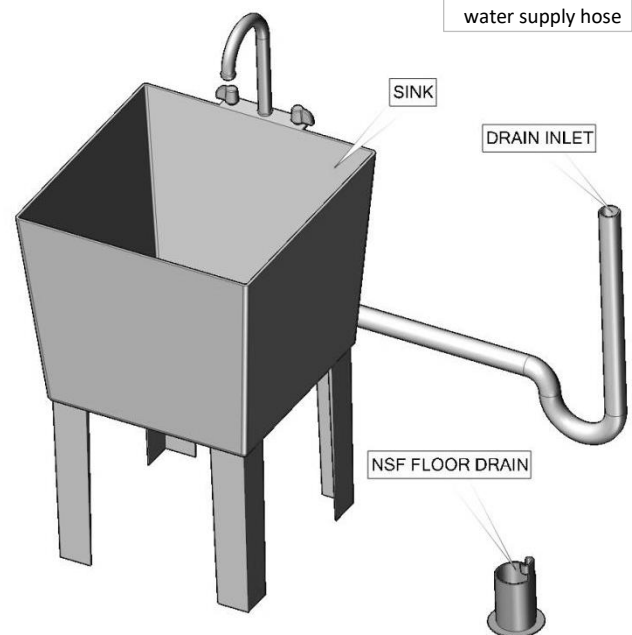

(Image for illustration only) FIG.2

Section 10: HRWAND128 Portable Wandstation

● GENERAL INFORMATION:

Refer to your operator's manual supplied with the HRWAND128 product for installation process and mounting information.

The "MOUNTING BRACKET" performs three simple features:

1. It provides a sturdy nesting place for the HRWAND128.
2. It's designed to be NSF compliant, meaning that it requires no tools for easy cleaning and removal for going mobile.
3. The lower hanging feature allows for easy stowing of the "POLYURETHANE 3/8" O.D. WATER SUPPLY HOSE"

As you will see the HRWAND128 is an important device used in the Hydra Rinse® cleaning process. It can be used on all hard-non-porous food contact related surfaces of all soft serve equipment during the Hydra Rinse® Process. The Wandstation eliminates the need for manual mixing of cleaner/sanitizer solution.

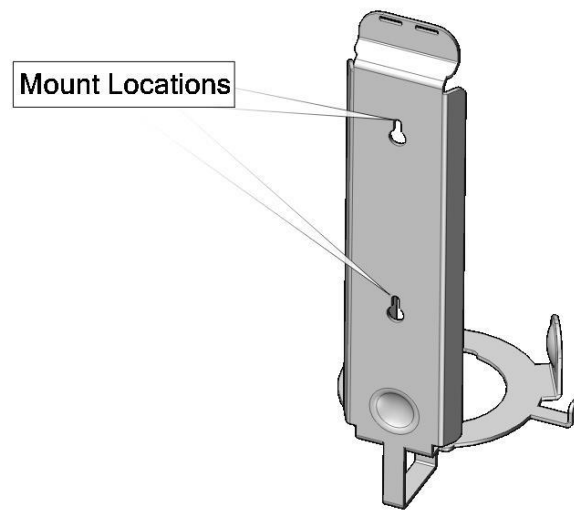

FIG.C

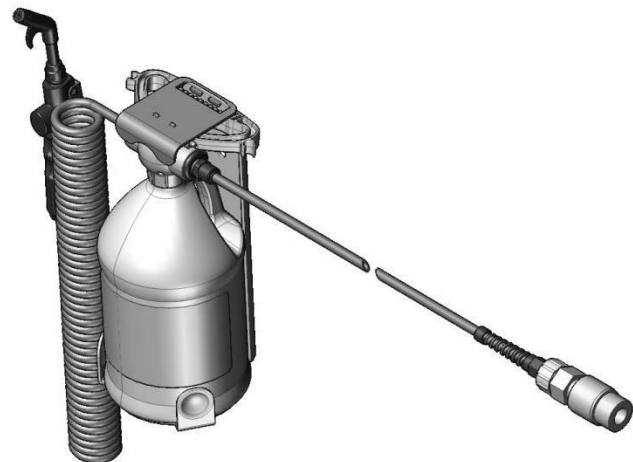

FIG.D

Section 11: Upgrade Components

● UPGRADE COMPONENTS:

Be sure to upgrade every soft serve machine that is intended for cleaning with the Hydra Rinse® System (www.hydrarinse.com). Hydra Rinse® upgraded components are specific for every TAYHR variant.

Installation of these upgrade components allows the Hydra Rinse® System to perform efficiently.

Food safe lube will no longer be applied to many of the illustrated components in **FIG.E**, with the exception to the machine "BEATER SHAFT".



(Image for illustration only) **FIG.E**

● MACHINE BEATER SHAFT:

As previously mentioned there will be no need for applying food safe lube directly to the upgraded Hydra Rinse® "BEATER SHAFT SEAL"; after cleaning "BEATER SHAFT", simply install the "BEATER SHAFT SEAL" as is.



But to maintain machine performance of the "BEATER SHAFT" itself, food safe lube will be required on the metal shaft as illustrated in **FIG.F**. This will ensure machine performance, while eliminating direct application of lube to your upgraded Hydra Rinse® "BEATER SHAFT SEAL".

NOTE: We recommend using "TAYLOR LUBE HP" for longer life and superior performance.

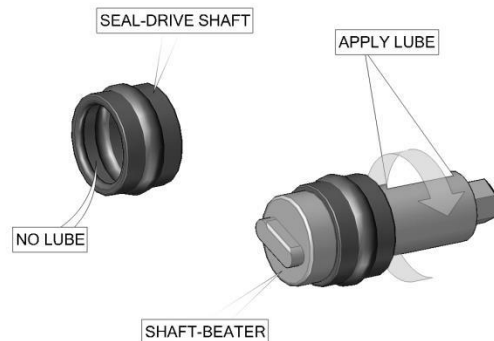

(Image for illustration only) **FIG.F**

Section 12: NSF Certified Hydra Rinse® Process

⚠ **Upgrading soft serve machine (Section 11: Upgraded Components) prior to performing the Hydra Rinse® Process is required** ⚠

- Step 1:** Review Section 14: "Details of the Hydra Rinse® Process" before referencing this document.
- Step 2:** Place machine in "Standby Mode". Wait approximately 4 to 5 hours for product to reach temperature >30°F (-1.1°C). Take machine out of "Standby" and de-activate "Mix Refrigeration Control". Prepare utility items e.g., buckets, brushes, etc.
- Step 3:** Begin filling first open bay of a "two-bay catch bucket" with ~2 US gallons of warm water 112.5°F (44.7°C), or LEXX™ solution.
- Step 4:** Remove product mix and mix tank(s); if there is a top cover(s), clean/sanitize using wand solution, wipes and/or towels (place on sanitized surface). Move the "two-bay catch bucket" into lower cabinet; place end of suction tube/adaptor(s) into empty bay.
- Step 5:** Turn on pump(s) and place machine in "Wash mode". Drain product mix from soft serve machine into a sanitized bucket if intended for re-run (immediately refrigerate).
- Step 6:** Carefully open prime plug(s) to release pressure (leave open). Now move ends of suction tube/adaptor(s) into solution bay. Allow pump(s) to pull solution from the "two-bay catch bucket". Fill freezer barrel(s) until discharge from the prime plug(s) occurs. Close prime plug(s). Place machine in "Wash mode" for each freezer barrel and let agitate for 2 minutes; drain freezer barrel(s). Repeat **Step 6** if removing frozen product mix or >10% fat content. De-activate the pump(s) but leave machine in "Wash mode".
- Step 7:** Slowly relieve pressure from freezer barrel(s) and then remove draw valve(s) from freezer door; flush draw valve port(s) with wand. Remove prime plug(s), rinse and then re-install them. Allow wand to replenish solution bay (~2 US gallons of LEXX™ solution).
- Step 8:** Wipe clean all exposed bottom surfaces of freezer door using wipes and/or towels. Install the Pro-control Module, and engage the Keeper Switch to secure Pro-control Module in place.
- Step 9:** Wet the Quick Connect on either the Pro-control Module or on the water supply hose with wand solution and/or wipes.
- Step 10:** Connect the water supply hose to the Pro-control Module. Remove cup housings from the Pro-control, and insert either 1 new LEXX™ Cup, or 2 fluid ounces of LEXX™ into each Cup Housing. Re-attach the cup housings to the Pro-control Module; ensure that the Token Tag is registered, and water source is turned on; remember to turn off wand if solution bay is adequately filled.
- Step 11:** Disconnect the Product Mix level Sensor Housing(s) and place in the solution bay of the "two-bay catch bucket".
- Step 12:** Disconnect the Product Mix Flare line(s) from the machine side, and position over the back/empty bay of the "two-bay catch bucket".
- Step 13:** Disconnect the pressure Sensor Line(s) from the Pressure Sensor Housing(s). Re-purpose one line for two-barrel machines by joining the two product mix pressure sensor outlets (machine side). Install magnetic splash guard if applicable.
- Step 14:** Connect the "Bypass system". Secure the bypass drain hose to one of the three acceptable drain sources.
- Step 15:** Review readiness check list. Press and then release the "ONE TOUCH" button to initialize the Pro-control Module cycle.
- Step 16:** Roughly 35 seconds and/or first sequential audible beeps from the Pro-control Module: Place soft serve machine into "Wash mode" for each freezer barrel. Turn on pump(s) and flush product mix delivery system until solution bay is at least 2/3 empty. Turn off pump(s).
- Step 17:** Begin removing any remaining components from the lower refrigeration compartment e.g., pump(s), etc. for mechanical scrubbing.
- Step 18:** Pause the Pro-control Module (~3.5 min. into cycle) when prompted (sequential audible beeps with all three LEDs Flashing). Take soft serve machine out of "Wash mode" for each freezer barrel, power off the soft serve machine. Disconnect the water supply hose, drain machine (Section 14 page 31) and then remove the Pro-control Module from the freezer door. Remove the freezer door and internal components of the soft serve machine for mechanical scrubbing; clean and then sanitize all components including all freezer door surfaces and freezer barrel surfaces; remember to mechanically scrub all product delivery lines, including those that extend from the freezer barrel(s) down to the lower refrigeration cabinet (you'll need to temporarily remove the bypass system). Clean all diaphragms. Remove the "two-bay catch bucket" and discard any residual solution. Re-assemble the soft serve machine, and then re-connect the Pro-control Module, bypass system and water supply hose. Power up the soft serve machine. Press and release the "PLAY/PAUSE" button on the Pro-control Module to resume cycle. Place soft serve machine back into "Wash mode" for each freezer barrel.
- Step 19:** Clean and sanitize the mix tank(s) and whatever still needs cleaning while the Pro-control is completing its cycle.
- Step 20:** When the "GREEN LED" is steadily blinking, the Pro-control Module cycle is complete. Take machine out of "Wash Mode" for each freezer barrel. Place the sanitized "two-bay catch bucket" under the Pro-control Module, remove the left cup housing; lift a prime plug to drain the sanitizing solution from machine (option to momentarily place machine back in "Wash Mode" to remove any residual sanitizing solution from freezer barrel(s)). Re-attach the left cup housing after draining is completed. Place "two-bay catch bucket" with drained sanitizing solution back into lower cabinet (option to re-sanitize product mix delivery system with drained LEXX™ solution).
- Step 21:** Disengage the Keeper Switch and remove the Pro-control Module. Remove bypass system and bucket from the lower cabinet. Give the lower refrigeration cabinet a good rinsing and wipe down. Connect the product mix flare line(s) from the pump(s) to the machine side.
- Step 22:** Wipe down soft serve machine outer shell with wipes and/or toweling. Replace the mix tank(s) and cover(s) if applicable. Check and clean all drip tray(s)/pan(s); remember to remove magnetic splash guard if applicable. Press and release the "PLAY/PAUSE" button.
- Step 23:** Reconnect the water supply hose to the Pro-control Module, and run "Self-clean Mode" while cleaning with wipes and/or towels (Enter self-clean mode by holding down both the "ONE TOUCH" and the "PLAY/PAUSE" buttons simultaneously for 5 seconds).
- Step 24:** Sanitize the bypass tube(s), OEM barrel brushes and anything else used during this process with wand solution before stowing.
- Step 25:** When adding product mix, be sure to prime machine in accordance with manufacturer's instructions, and re-install mix tank cover(s) if applicable; place machine in "Auto Mode". If product mix is not being added back into the soft serve machine within 72 hrs. following this process: Remove the freezer door and all internal components for air drying.

Remember to perform a Pro-control self-cleaning cycle after every use.

Section 13: NSF Certified Flavor Change Process

✦ **Upgrading soft serve machine (Section 11: Upgraded Components) prior to performing the Hydra Rinse® Process is required** ✦

- Step 1:** Review Section 14: "Details of the Hydra Rinse® Process" before referencing this document.
- Step 2:** Place machine in "Standby Mode". Wait approximately 4 to 5 hours for product to reach temperature >30°F (-1.1°C). Take machine out of "Standby" and de-activate "Mix Refrigeration Control". Prepare utility items e.g., buckets, brushes, etc.
- Step 3:** Begin filling first open bay of a "two-bay catch bucket" with ~2 US gallons of warm water 112.5°F (44.7°C), or LEXX™ solution.
- Step 4:** Remove product mix and mix tank(s); if there is a top cover(s), clean/sanitize using wand solution, wipes and/or towels (place on sanitized surface). Move the "two-bay catch bucket" into lower cabinet; place end of suction tube/adaptor(s) into empty bay.
- Step 5:** Turn on pump(s) and place machine in "Wash mode". Drain product mix from soft serve machine into a sanitized bucket if intended for re-run (immediately refrigerate).
- Step 6:** Carefully open prime plug(s) to release pressure (leave open). Now move ends of suction tube/adaptor(s) into solution bay. Allow pump(s) to pull solution from the "two-bay catch bucket". Fill freezer barrel(s) until discharge from the prime plug(s) occurs. Close prime plug(s). Place machine in "Wash mode" for each freezer barrel and let agitate for 2 minutes; drain freezer barrel(s). Repeat **Step 6** if removing frozen product mix or >10% fat content. De-activate the pump(s) but leave machine in "Wash mode".
- Step 7:** Slowly relieve pressure from freezer barrel(s) and then remove draw valve(s) from freezer door; flush draw valve port(s) with wand. Remove prime plug(s), rinse and then re-install them. Allow wand to replenish solution bay (~2 US gallons of LEXX™ solution).
- Step 8:** Wipe clean all exposed bottom surfaces of freezer door using wipes and/or towels. Install the Pro-control Module, and engage the Keeper Switch to secure Pro-control Module in place.
- Step 9:** Wet the Quick Connect on either the Pro-control Module or on the water supply hose with wand solution and/or wipes.
- Step 10:** Connect the water supply hose to the Pro-control Module. Remove cup housings from the Pro-control, and insert either 1 new LEXX™ Cup, or 2 fluid ounces of LEXX™ into each Cup Housing. Re-attach the cup housings to the Pro-control Module; ensure that the Token Tag is registered, and water source is turned on; remember to turn off wand if solution bay is adequately filled.
- Step 11:** Disconnect the product mix level sensor housing(s) and place in the solution bay of the "two-bay catch bucket".
- Step 12:** Disconnect the product mix flare line(s) from the machine side, and position over the back/empty bay of the "two-bay catch bucket". Mechanically scrub product delivery lines that extend from the freezer barrel(s) down to the lower refrigeration cabinet when cleaning product mix with high fat content (10% or greater) and/or has added particulates.
- Step 13:** Disconnect the pressure sensor line(s) from the pressure sensor housing(s). Re-purpose one line for two-barrel machines by joining the two product mix pressure sensor outlets (machine side). Install magnetic splash guard if applicable.
- Step 14:** Connect the "Bypass system". Secure the bypass drain hose to one of the three acceptable drain sources.
- Step 15:** Review readiness check list. Press and then release the "ONE TOUCH" button to initialize the Pro-control Module cycle.
- Step 16:** Roughly 35 seconds and/or first sequential audible beeps from the Pro-control Module: Place soft serve machine into "Wash mode" for each freezer barrel. Turn on pump(s) and flush product mix delivery system until solution bay is at least 2/3 empty. Turn off pump(s).
- Step 17:** If machine is equipped with piston pump(s): Remove the pump body valve, mix inlet elbow, black rubber poppet and spring for a thorough rinsing with the wand only; then re-assemble. Remove the check valve from the product mix adaptor(s) if applicable.
- Step 18:** Remove and empty the "two-bay catch bucket"; clean and sanitize. Manually scrub clean and sanitize any components removed during **Step 7**. Clean and sanitize mix tank(s).
- Step 19:** When the "GREEN LED" is steadily blinking, the cycle is complete. Take machine out of "Wash Mode" for each freezer barrel. Place the sanitized "two-bay catch bucket" under the Pro-control Module, remove left cup housing; lift a prime plug to drain the sanitizing solution from machine (option to momentarily place machine back in "Wash Mode" to remove any residual sanitizing solution from the freezer barrel(s)). Re-attach left cup housing after draining is completed. Place the "two-bay catch bucket" back into lower cabinet. Reposition the product mix flare line(s) over the back/empty bay of the "two-bay catch bucket". Disconnect water supply from the Pro-control Module, slide Keeper Switch back into the neutral position and remove the Pro-control Module from the freezer door.
- Step 20:** Activate pump(s) and flush the drained LEXX™ sanitizing solution through the lower product mix delivery system. Clean all Diaphragms according to manufactures recommendations.
- Step 21:** Pull prime plug(s) for thorough cleaning and sanitizing. Use wand solution, OEM barrel brushes, wipes and/or towels to mechanically scrub draw valve and prime plug port(s).
- Step 22:** Reinstall draw valve(s) and prime plug(s).
- Step 23:** Wipe down soft serve machine outer shell with wipes and/or toweling. Remove the "two-bay catch bucket", rinse down and wipe the entire lower refrigeration cabinet. Return all hoses and mix tank(s) to their operational positions. Check and clean all drip tray(s)/pan(s). Remember to remove magnetic splash guard if applicable. Press and release the "PLAY/PAUSE" button.
- Step 24:** Reconnect Water Supply Hose to the Pro-control Module, and run "Self-clean Mode" while cleaning with wipes and/or towels (Enter self-clean mode by holding down both the "ONE TOUCH" and the "PLAY/PAUSE" buttons simultaneously for 5 seconds).
- Step 25:** Sanitize bypass tube(s), OEM barrel brushes and anything else used during this process with wand solution before stowing.
- Step 26:** When adding product mix, be sure to prime machine in accordance with manufacturer's instructions, and re-install mix tank cover(s) if applicable; place machine in "Auto Mode". If product mix is not being added back into the soft serve machine within 72 hrs. following this process: Remove the freezer door and all internal components for air drying.

Remember to perform a Pro-control self-cleaning cycle after every use.

Section 14: Details of the Hydra Rinse® Process

● PREPERATION OF UTILITY ITEMS:

It's always good practice to clean and sanitize all utility items like Waste catch buckets and OEM brushes before beginning the cleaning and sanitizing of the soft serve machine; use the HRWAND128 and Hydra Rinse® Wipes for time savings and operator efficiency.



(Image for illustration only) **FIG.1**

● DISABLE AUTO MODE:

Allow the soft serve machine to be in "STANDBY" **FIG.2** for a minimum of 4 hours to optimize the volume of product mix recovery. This step will reduce the number of pre-rinse cycles required when compared to removing frozen product mix from the freezer barrel(s).

You can begin filling one side of a "TWO-BAY CATCH BUCKET" (page 18) at this stage of the process with ~2 US gallons of warm water 112.5°F (44.7°C); use LEXX™ solution when removing frozen product mix from the freezer barrel(s).

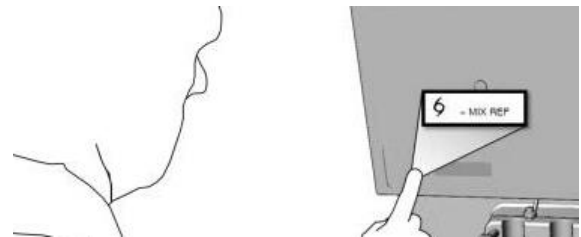

(Image for illustration only) **FIG.2**

Ensure that "AUTO MODE" is disabled for each freezer cylinder.

Tip: Lock the HRWAND128 Trigger in the dispensing position for automatic operation.

Note: Using the LEXX™ sanitizing and cleaning solution in place of warm water 112.5°F (44.7°C) will increase the proficiency associated with the removal of frozen product mix (also suggested for product mix with greater than or equal to 10% fat content).

Section 14: Details of the Hydra Rinse® Process

● PREPPING LOWER CABINET:

If machine is configured to use product mix in bags instead of directly being added to the "MIX TANK(S)", disconnect "SUCTION TUBE/ADAPTOR(S)" **FIG.3**; immediately place product mix in refrigeration. Move the "SUCTION TUBE/ADAPTOR(S)" into the open bay of the "TWO-BAY CATCH BUCKET", or a temporary sanitized catch bucket.

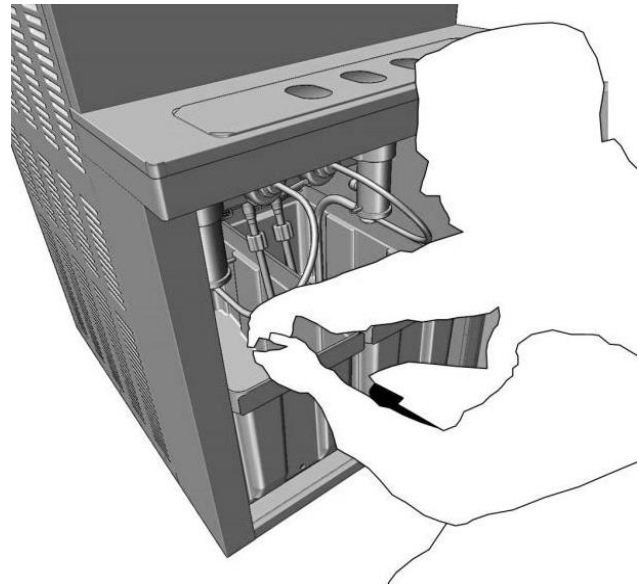

(Image for illustration only) **FIG.3**

Note: Ensure that the "MIX REFRIGERATION CONTROL" is disabled **FIG.4**

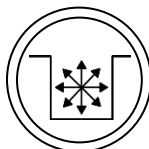
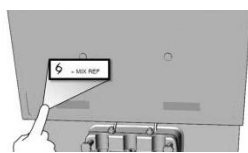
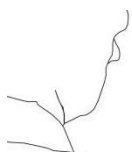

(Image for illustration only) **FIG.4**

● SUCTION TUBE INLET:

It's important that the "SUCTION TUBE INLET(S)" is unobstructed during the cleaning and sanitizing process. If the suction tube/adaptor(s) is equipped with a one-way check valve **FIG.5**, leave it in place until instructed otherwise.

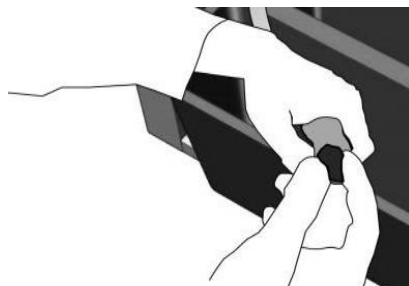

(Image for illustration only) **FIG.5**

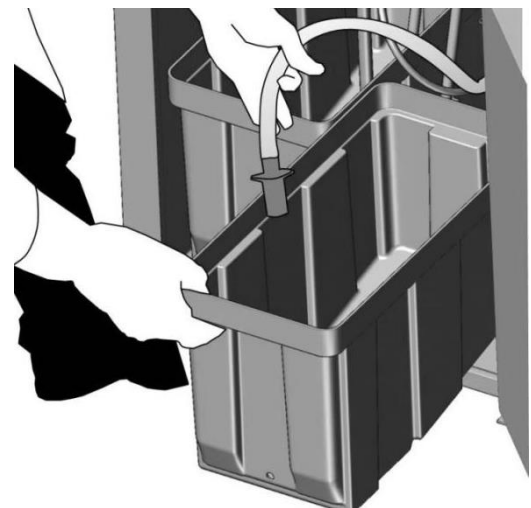

(Image for illustration only) **FIG.6**

Section 14: Details of the Hydra Rinse® Process

○ REMOVE PRODUCT FROM MACHINE:

It doesn't matter what type of soft serve machine it is i.e., single barrel or double barrel. Try to remove as much frozen/thawed product mix as possible; never attempt to use the Hydra Rinse® System with more than 75% frozen or thawed product mix present in the "FREEZER BARREL(S)"; use the "HRWAND128" and "HYDRA RINSE® WIPES" to clean and sanitizer all catch buckets and OEM brushes prior to product removal.



(Image for illustration only) **FIG.7**

Note: If your machine is equipped with "MIX TANK COVER(S)", clean and sanitize prior to removing product and then place on a sanitized surface; this will allow enough time for air drying before re-assembly.

Reminder: If you haven't yet, you can begin adding warm water or LEXX™ solution to the "TWO-BAY CATCH BUCKET" while draining product simultaneously to save time (page 18).

○ PRODUCT MIX RE-RUN:

Once product mix has been removed from the freezer barrel(s), immediately refrigerate.



(Image for illustration only) **FIG.8**

Note: Refer to State and local health codes for re-run permissibility.

Section 14: Details of the Hydra Rinse® Process

● TWO-BAY CATCH BUCKET:

After removing the "MIX TANK(S)" from the lower refrigeration cabinet, replace them with a "TWO-BAY CATCH BUCKET"; place the ends of the "SUCTION TUBE/ADAPTOR(S)" into the open/empty bay as illustrated **FIG.9**.

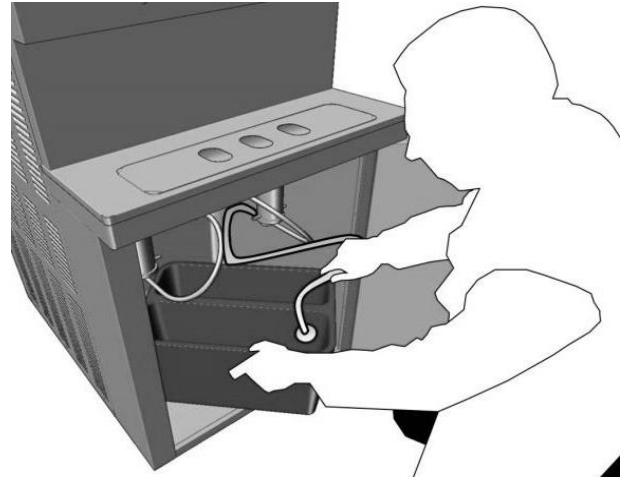

NOTE: Ensure catch bucket is cleaned and sanitized before use.

(Image for illustration only) **FIG.9**

● ADD WARM WATER OR LEXX SANITIZER/CLEANER:

Ensure an open bay of the "TWO-BAY CATCH BUCKET" is filled with either ~2 US gallons of warm water 112.5°F (44.7°C), or LEXX™ solution **FIG.10**. The HRWAND128 has a locking feature on the trigger. Simply press down and then slide the trigger forward to temporarily lock the trigger into the dispensing position **FIG.11**. Allow LEXX™ to continue dispensing (dispense rate is ¼ US gallons per minute).

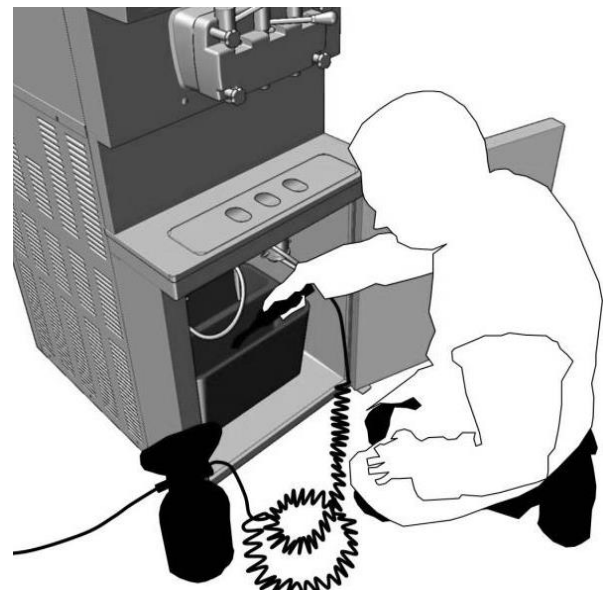

(Image for illustration only) **FIG.10**

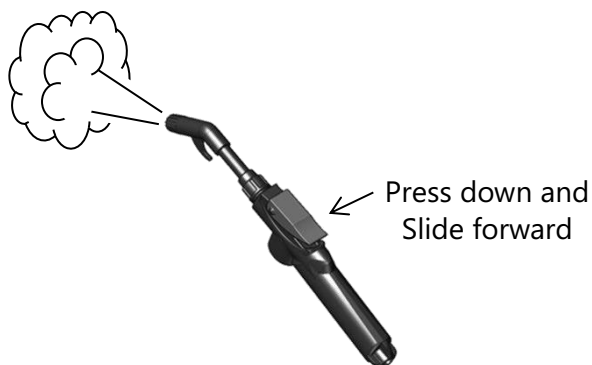

(Image for illustration only) **FIG.11**

Section 14: Details of the Hydra Rinse® Process

○ PRE-RINSE FREEZER BARRELS:

Place a catch bucket underneath the "FREEZER DOOR".



Open the "PRIME PLUG(S)", and then activate the "PUMP(S)" to allow the solution to fill the "FREEZER BARREL(S)"; continue filling until you see visible discharge coming from the open "PRIME PLUG(S) PORT(S)".

Close the "PRIME PLUG(S)" and immediately place machine in "WASH MODE" for each freezer barrel; ~2 minutes of agitation; allow the HRWAND128 to re-fill the two-bay catch bucket **FIG.12**.

Next, drain the solution from the freezer barrel(s), while allowing a portion of discharge solution to flow through all "DRAW VALVE(S)".

After replenishing the "TWO-BAY CATCH BUCKET" with LEXX™ solution (keep volume at ~2 US gallons), disengage the wand trigger to pause filling

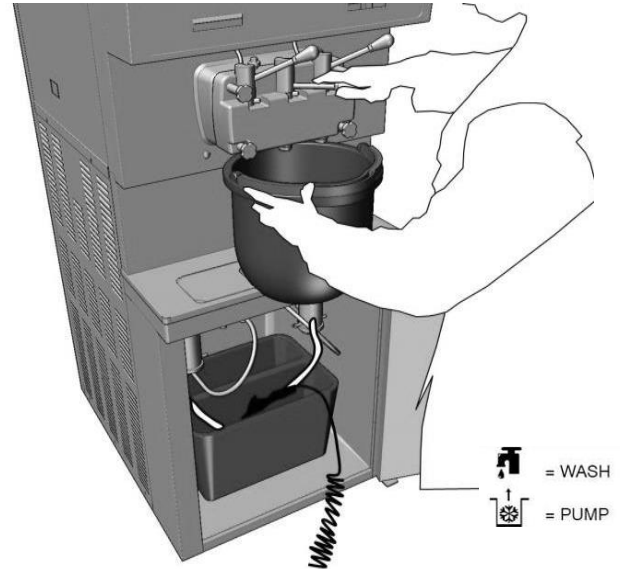

Note: Common practice is to carefully relieve pressure from the freezer barrel(s) using the "PRIME PLUG(S)" before engaging the "DRAW VALVE(S)" to minimize spray.

(Image for illustration only) **FIG.12**

Note: Repeat this process one more time to adequately pre-rinse the "FREEZER BARREL(S)" if performing this process without allowing the machine to be in "STANDBY MODE" for a minimum of 4 hour, or product mix is greater than or equal to 10% fat content.

"DRAW VALVE(S)" and "PRIME PLUG(S)" have been re-designed to be lube-free **FIG.13**. Details can be found in the accompanying Upgrade Kit Manual.

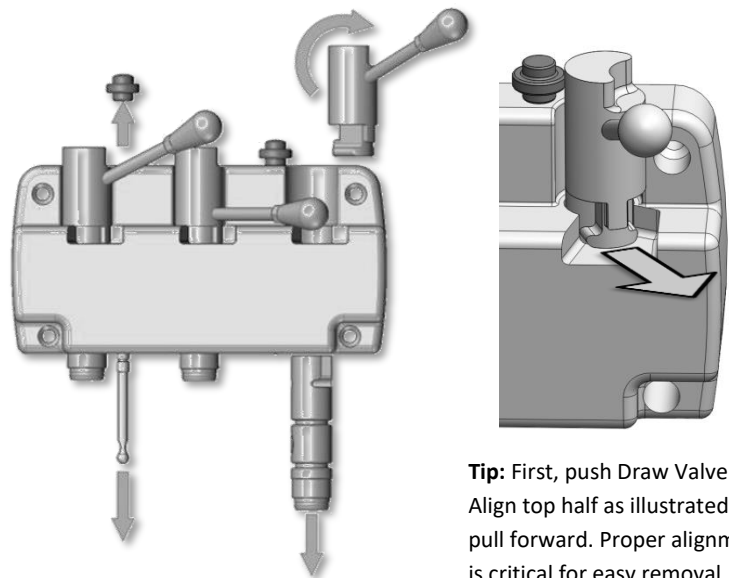

Tip: First, push Draw Valve up. Align top half as illustrated and pull forward. Proper alignment is critical for easy removal.

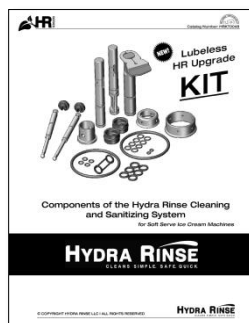

← Flexible Prime Plug Variant

(Image for illustration only) **FIG.13**

Section 14: Details of the Hydra Rinse® Process

○ PREPARING FREEZER DOOR:

Turn off the “PUMP(S)” but leave the machine in “WASH MODE”. Removing the “DRAW VALVE(S)”, and the “PRIME PLUG(S)” **FIG.14**. If the “PRIME PLUG CAP(S)” is removable, remove the cap and push the prime plug down to remove it from the bottom of the freezer door, or from the top if using the “FLEXIBLE VARIANT”. If “PRIME PLUG(S)” are not removable, place them in the open position (pull upward) for flushing with the “HRWAND128”.

Removable “PRIME PLUG(S)” allows for more than just ease of cleaning: The ability to replace O-rings without removal of the freezer door increases productivity; this is also true for the removable draw valve(s).

Tip: Leaving the machine in “WASH MODE” while removing the draw valve(s) will maximize the amount of solution removed from the freezer barrel(s) prior to installing the “PRO-CONTROL MODULE”. You can subsequently disconnect the

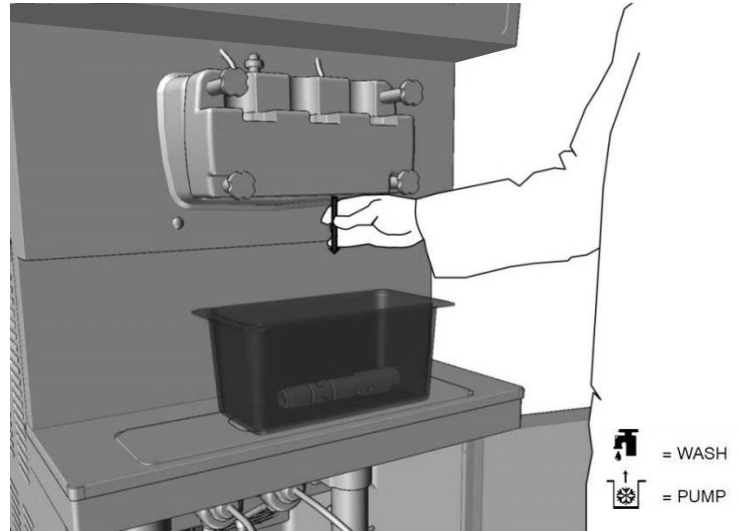

(Image for illustration only) **FIG.14**

“PRODUCT MIX FLARE LINE(S)” (page 25) at this stage of the process to shorten the amount of time required to remove the solution from the freezer barrel(s); take the machine out of “WASH MODE” once visual dripping of solution has come to an acceptable level.

○ PRE-RINSE PRIME PLUG:

Pre-rinse the removable “PRIME PLUG(S)” using the “HRWAND128” **FIG.15**.

If the “PRIME PLUG(S)” is not removable, chase some sanitizer/cleaner solution up through the “PRIME PLUG PORT(S)” using the “HRWAND128” for roughly 5 seconds while simultaneously oscillating the prime plug upward and downward.

Once completed, re-install the removable prime plug(s), and ensure they are in the closed position; this is also the case for non-removable prime plug(s).

Note: It’s important that the “PRIME PLUG(S)” are present and in the closed position before installing the “PRO-CONTROL MODULE”.

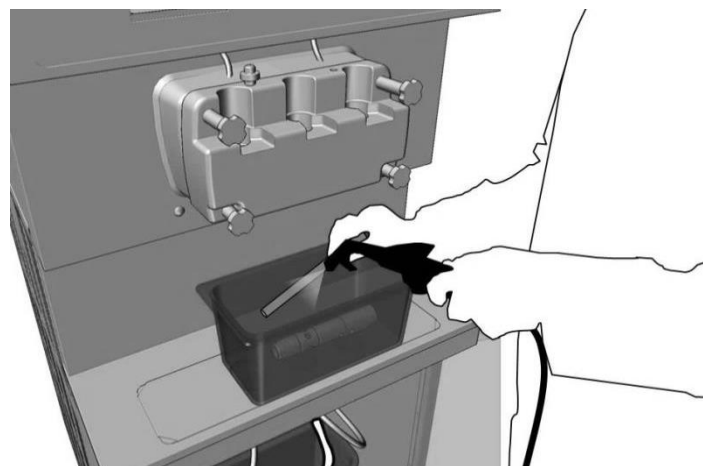

(Image for illustration only) **FIG.15**

Section 14: Details of the Hydra Rinse® Process

○ PREPARING FOR THE PRO-CONTROL MODULE:

Currently, ensure the machine is out of "WASH MODE" for each freezer barrel **FIG.16**.

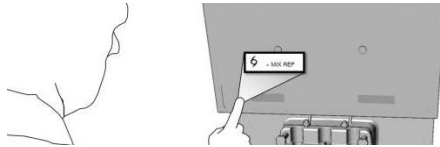

(Image for illustration only) **FIG.16**

Wipe all soiled "FREEZER DOOR" surfaces clean using "HYDRA RINSE® WIPES" **FIG.17**.

Note: Using disposable wipes instead of re-usable cleaning towels is a big game changer in reducing the potential of recontamination during the clean and sanitizing process.

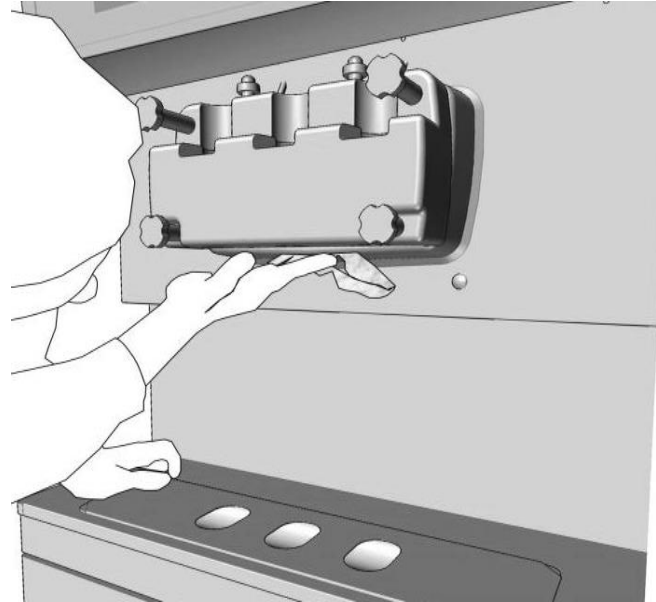

(Image for illustration only) **FIG.17**

○ INSTALL PRO-CONTROL MODULE:

To assist with installing the "PRO-CONTROL MODULE", wet the O-rings on the pistons with either a "HYDRA RINSE® WIPE" or with sanitizer/cleaner solution from the wand.

Simply use the "CENTER PISTON" to guide the unit up into the "CENTER DRAW VALVE PORT"; once the piston O-rings begin to contact the "DRAW VALVE PORT(S)", gently wiggle the unit while pushing upward on the ends of the underside of the "INTERFACE MANIFOLD ASSEMBLY"; use door "NUT STUDS" to make things even easier **FIG. 18**.

On the top of the "CENTER PISTON" is the "KEEPER SWITCH". The "PRO-CONTROL MODULE" is in position when the "KEEPER SWITCH" can freely slide forward **FIG.19**, securing the unit into place.

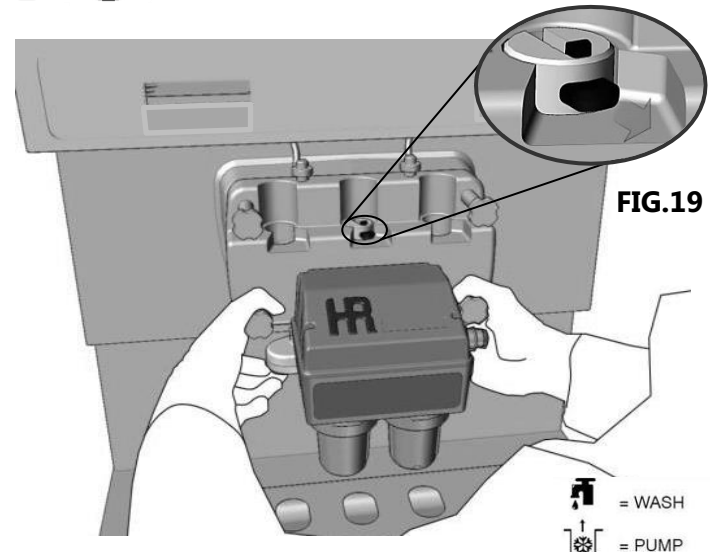

(Image for illustration only) **FIG.18**

Section 14: Details of the Hydra Rinse® Process

○ CONNECT WATER SUPPLY:

Prior to connecting the "WATER SUPPLY", wet the O-ring on the "PRO-CONTROL MODULE QUICK CONNECT" **FIG.20** with either a "HYDRA RINSE® WIPE" or with the sanitizer/cleaner solution; once connected, if the water source has not been turned on yet, you will need to do so before adding the LEXX™ concentrate.

Note: Always ensure cup housings are present and that you haven't added new LEXX™ concentrate until the water source is connected and turned on.

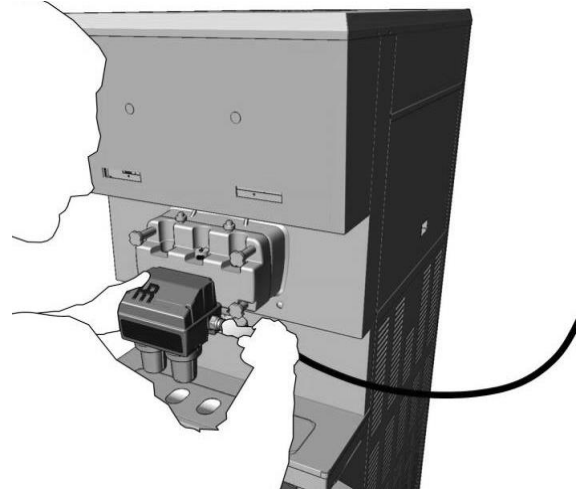

(Image for illustration only) **FIG.20**

○ ADDING LEXX™ CONCENTRATE:

To remove the left "CLEANER CUP HOUSING", rotate outward from the center of the Pro-control Module for less than a quarter turn. To remove the right "SANITIZER CUP HOUSING", once again rotate outward from the center of the Pro-control Module for less than a quarter turn.

Put 1 ready to use "LEXX™ CUP" or 2 fluid ounces of LEXX™ concentrate into each of the cup housings.

While pushing the nested "LEXX™ CUP" up into the piercing features of the "PRO-CONTROL MODULE", align the mating features of the "CUP HOUSING" to the main body; pay close attention that the cup lid has been adequately pierced.

Practice working with the "CUP HOUSINGS" prior to adding actual cups.

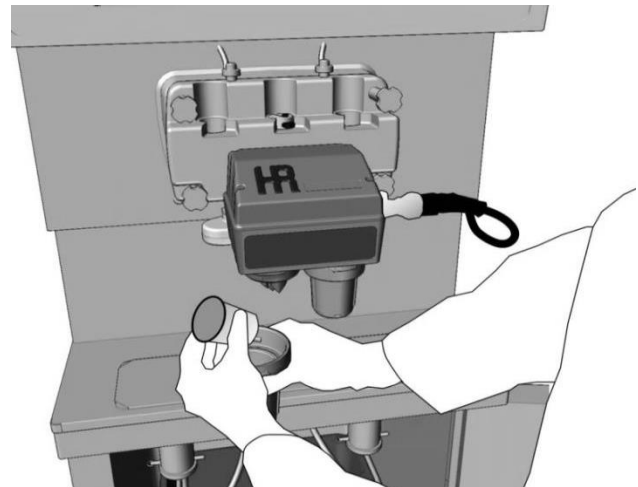

(Image for illustration only) **FIG.21**

Note: Lube the cup housing face seal **FIG.22** with food safe lube when "ALIGNMENT ARROWS" become difficult to align.

Lube sealing face,
not O-ring
(Bottom View)

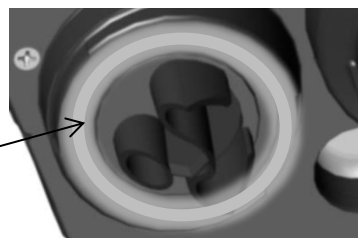

FIG.22

Section 14: Details of the Hydra Rinse® Process

● TIGHTEN CUP HOUSINGS:

It's important that sanitizer/cleaner solution is present during every cycle, so too is proper tightening of both the "CLEANER CUP HOUSING" and the "SANITIZER CUP HOUSING".

To tighten the cup housings, rotate inward towards the center of the "PRO-CONTROL MODULE". As called out in **FIG.23**, there are corresponding "ALIGNMENT ARROWS" molded into the plastic components; for proper seal, ensure they are aligned together as illustrated.

Tip: (See "Storage", page 39 for proper arrow alignment for Pro-control Module when not in use.)

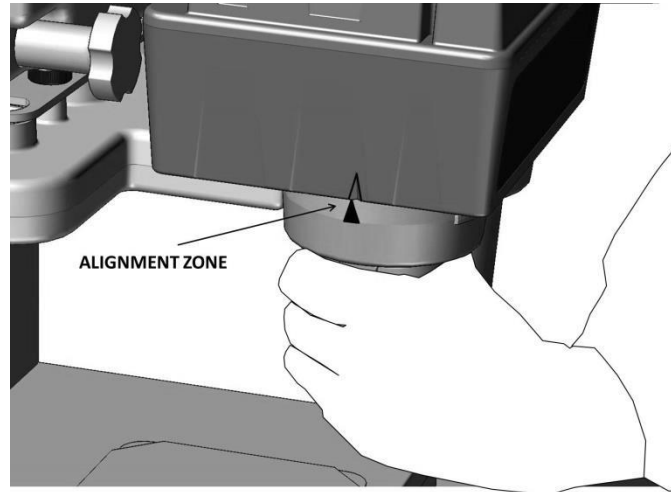

(Image for illustration only) **FIG.23**

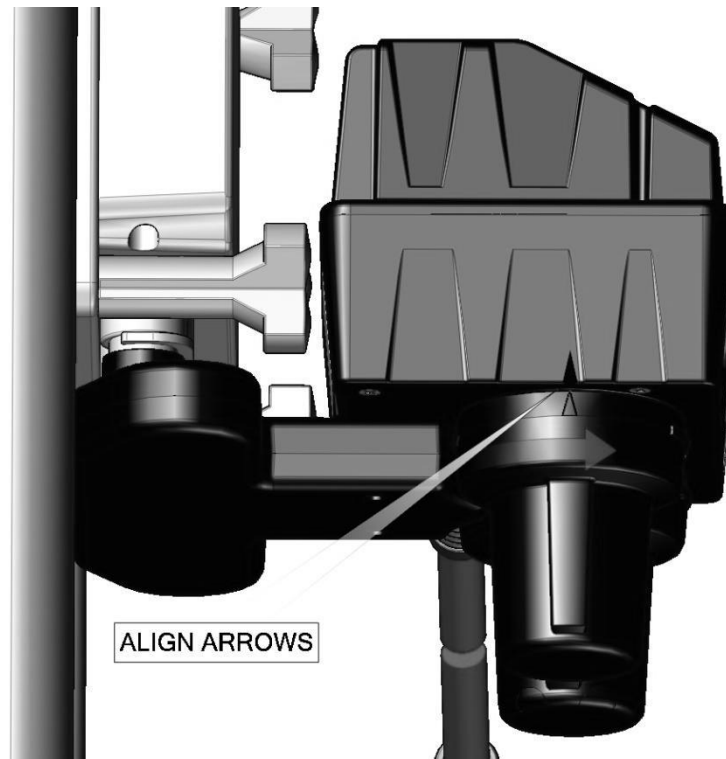

(Image for illustration only) **FIG.24**

Section 14: Details of the Hydra Rinse® Process

○ REMOVE PRODUCT LEVEL SENSOR(S):



Once everything is in place: The “PRO-CONTROL MODULE” will take care of the upper portion of the soft serve machine, while the machine pump(s), along with the “HRWAND128” and “TWO-BAY CATCH BUCKET” will take care of the lower portion of the soft serve machine’s food path for cleaning and sanitizing.

Before installing the “BYPASS SYSTEM”, it’s important to position all the lower refrigeration cabinet hoses and sensors correctly for proper cleaning and sanitizing.

Disconnect all “PRODUCT MIX LEVEL SENSOR(S)”. If sensor is a quick disconnect with tubing connected to the pump **FIG.25**, leave tubing connected to both the quick disconnect and pump as illustrated **FIG.26**

Place the “SUCTION TUBE/QUICK DISCONNECT(S)” in the solution side of the “TWO-BAY CATCH BUCKET”; ensure you don’t remove the “MIX LEVEL SENSOR PROBE MODULE” from the machine electrical connecting block, only the quick disconnect with tubing as illustrated **FIG.26**; for variant sensor, scrub manually.

Note: Soaking the Mix Level Sensor Probe Module itself may result in rendering the sensor inoperable.

Do not soak the Variant Mix Level Sensor(s).

Mix Level Sensor Probe Module

Dispense roughly 2 US gallons of solution

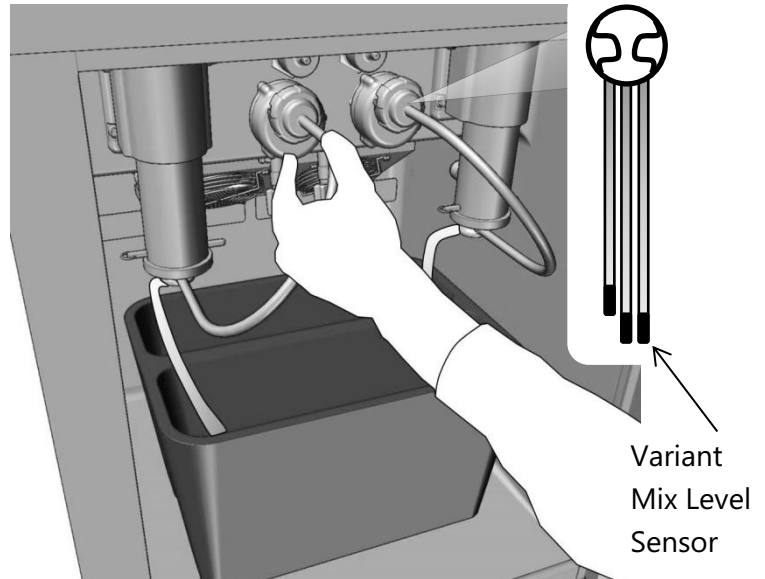

(Image for illustration only) **FIG.25**

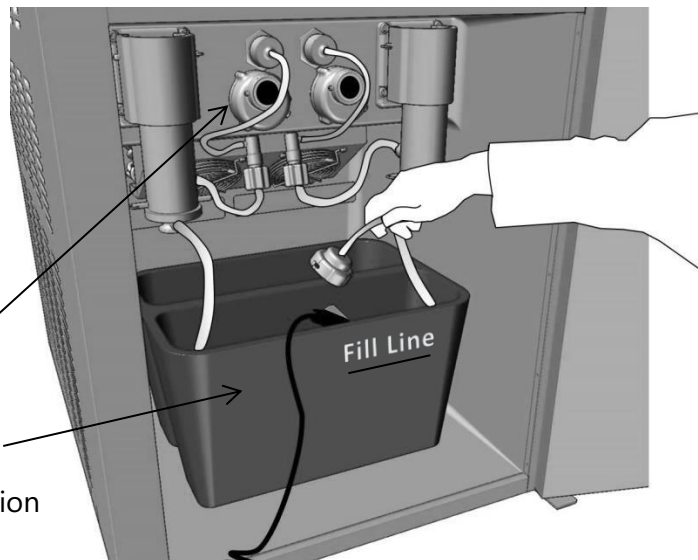

(Image for illustration only) **FIG.26**

Note: Stop dispensing solution after ~2 US Gallons has filled the bucket in total volume.

Section 14: Details of the Hydra Rinse® Process

○ REMOVE FLARE LINE(S):

If you haven't yet, unthread the "PRODUCT MIX FLARE LINE(S)" from the machine side as illustrated **FIG.27**.

To get the end of the product mix flare line to lie correctly within the open/empty bay of the "TWO-BAY CATCH BUCKET", you may have to loosen the product mix flare line from the pump outlet side to re-position as illustrated in **FIG.28**; once in place, re-tighten the product mix flare line enough (pump side) to keep line from moving during the cleaning and sanitizing cycle.

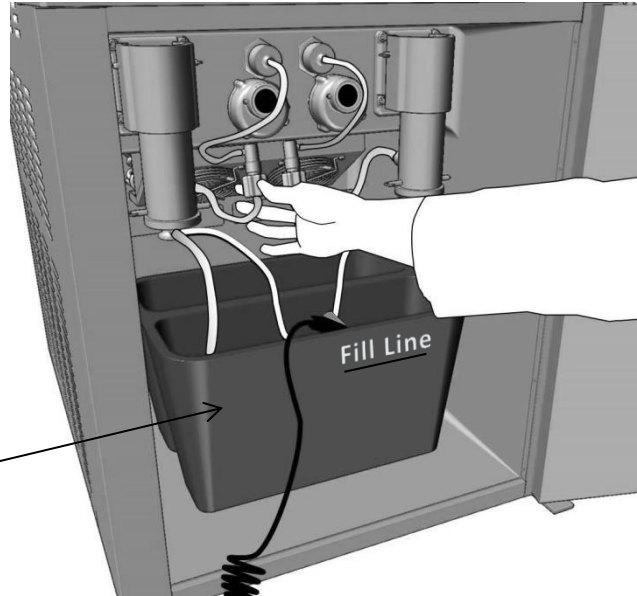

Dispense roughly
2 US Gallons of solution

Note: Stop dispensing solution after ~2 US gallons has filled the bucket in total volume.

(Image for illustration only) **FIG.27**

○ REMOVE PRESSURE SENSOR LINE(S):

Remove the "PRESSURE SENSOR LINE(S)" **FIG.29** from the pressure sensor housing (detach from the quick disconnect fitting, leave housing in position until instructed otherwise).

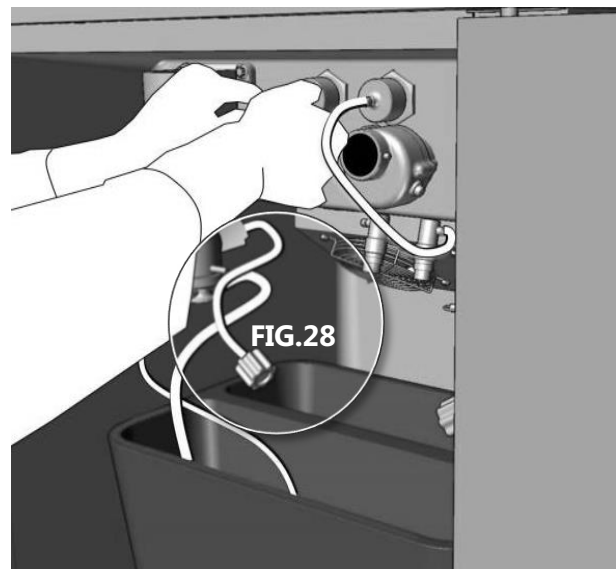

Note: For two-barrel machines, one "PRESSURE SENSOR LINE" will be re-purposed for use during the Hydra Rinse® cleaning and sanitizing cycle.

(Image for illustration only) **FIG.29**

Section 14: Details of the Hydra Rinse® Process

● RE-PURPOSE PRESSURE SENSOR LINE:

If your soft serve model has two freezer barrels, you'll need to combine the two "PRODUCT MIX PRESSURE SENSOR OUTLETS" with one of the "PRESSURE SENSOR LINES" as illustrated **FIG.30**.



(optional) Magnetic Splash Guard
(White Surface Facing Outward)

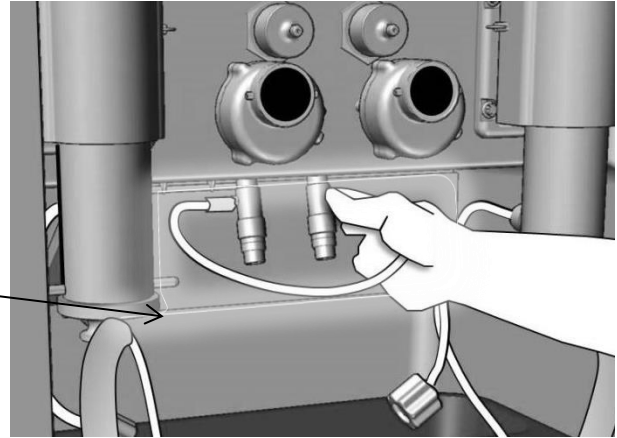

Note: Ensure the (optional) "MAGNETIC SPLASH GUARD" is in place from this point forward.

(Image for illustration only) **FIG.30**

● INSTALLING BYPASS SYSTEM:

Each TAYHR variant comes with the required "BYPASS SYSTEM" for properly connecting to the "25' BYPASS SYSTEM DRAIN HOSE".

Before connecting the "BYPASS FLARE LINE(S)" to the Product Mix Inlet Flare Connection(s) **FIG.31**: perform a mechanical scrubbing when using high particulate and/or product mix greater than or equal to 10% fat content; ensure the "MAGNETIC SPLASH GUARD" is in place.

For added ease of installation, gently wiggle the "BYPASS FLARE CONNECTING NUT" while pressing the flare connecting flange firmly against mating part.

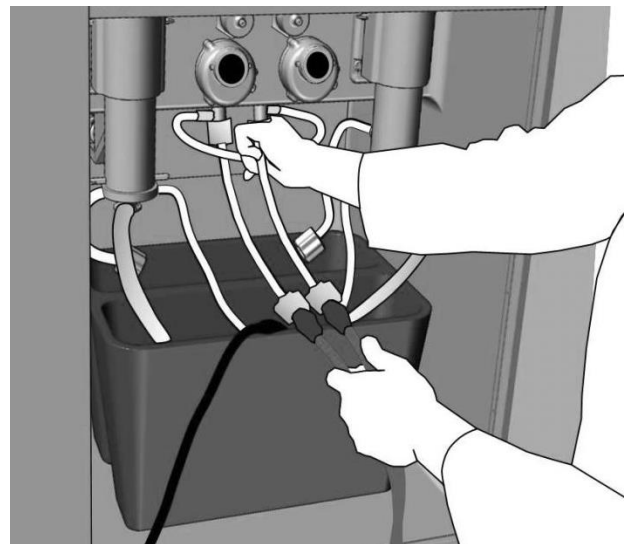

(Image for illustration only) **FIG.31**

● SECURING BYPASS DRAIN HOSE:

Whichever option you choose for your drain source, ensure that the "25' BYPASS SYSTEM DRAIN HOSE" is not only properly secured, but also properly positioned about the drain to ensure compliance with State and local health codes, which addresses backflow prevention.

Note: The Hydra Rinse® "BYPASS SYSTEM" is equipped with a check valve.

Section 14: Details of the Hydra Rinse® Process

START THE PRO-CONTROL MODULE CYCLE:



Run through this suggested check list before continuing:

- Bypass System in place, flare line(s) properly positioned in the open/empty bay of the “two-bay catch bucket”.
- Bypass System Drain Hose attached and secured to 1 of the 3 acceptable drain sources (page 10).
- Specified sanitary water source (page 1) connected and turned on.
- Re-install Prime plug(s) in freezer door if present.
- Fresh LEXX™ concentrate present in both the cleaning and sanitizing cup housings.
- Soft Serve Machine power is “ON”.

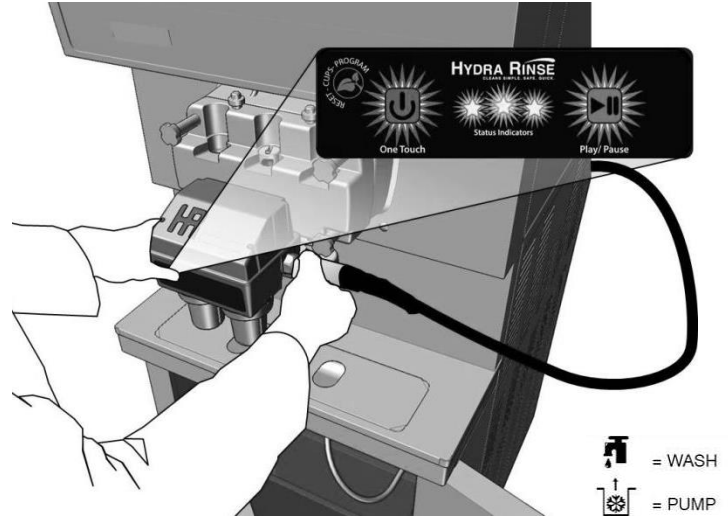

(Image for illustration only) **FIG.32**

Press and then release the “ONE TOUCH” **FIG.32** button on the “USER INTERFACE” to start the “PRO-CONTROL MODULE CYCLE”. Wait 35 seconds and/or first beep sequence of the “PRO-CONTROL MODULE CYCLE”, and then place the soft serve machine in “WASH MODE”.

If for any reason there arises a need to quickly cancel the “PRO-CONTROL MODULE CYCLE”, press and then release the “PLAY/PAUSE” button **FIG.33** within 15 seconds of pressing “ONE TOUCH”; the cycle will be canceled.

If it’s been longer than 15 seconds since pressing the “ONE TOUCH” button, the cycle cannot be canceled, only paused and the total available cycles will receive a “DING” i.e., 100-1 = 99 remaining cycles.

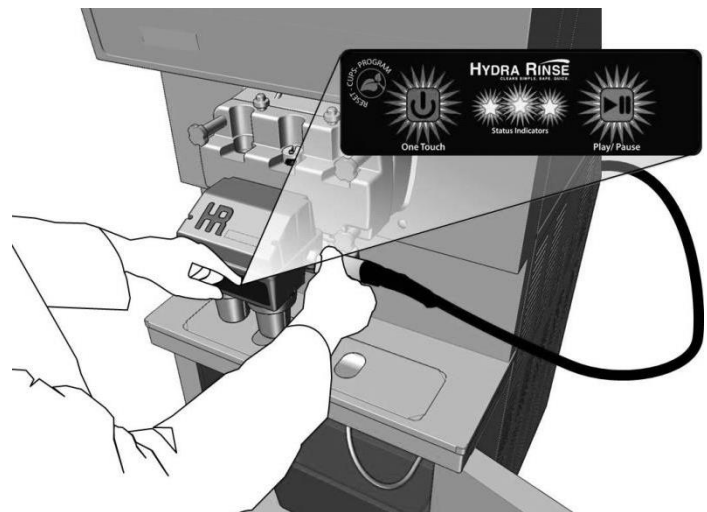

(Image for illustration only) **FIG.33**

Note: Pressing and releasing the “PLAY/PAUSE” button **FIG.33** after the 15 second cancelation window has lapsed will only suspend the “PRO-CONTROL MODULE CYCLE” indefinitely until the “PLAY/PAUSE” button is pressed and released again to resume it; this allows end users to make any necessary adjustments when required.

Warning: If you press and then release the “RESET-CUPS-PROGRAM” button after the cycle has commenced, or any time before it has completed, your cycle will be aborted causing the “PRO-CONTROL MODULE” to reboot. You will be “DINGED”, losing 1 cycle as if that cycle had completed successfully, so be mindful.

Section 14: Details of the Hydra Rinse® Process

○ PRE-CLEAN PRODUCT MIX DELIVERY SYSTEM:



While the “PRO-CONTROL MODULE” is performing the automated cleaning and sanitizing cycle on the upper portion of the soft serve machine (~7 minutes), it’s time to perform the manual cleaning and sanitizing process on the lower delivery system.

With all hoses in their proper position **FIG.34** and a minimum of 2 US gallons of solution in the front portion of the “TWO-BAY CATCH BUCKET”: Activate the “PUMP(S)”. The solution will be drawn from the front bay and captured by the back bay. Once most of the solution has traveled through the lower delivery system, deactivate the pump(s).

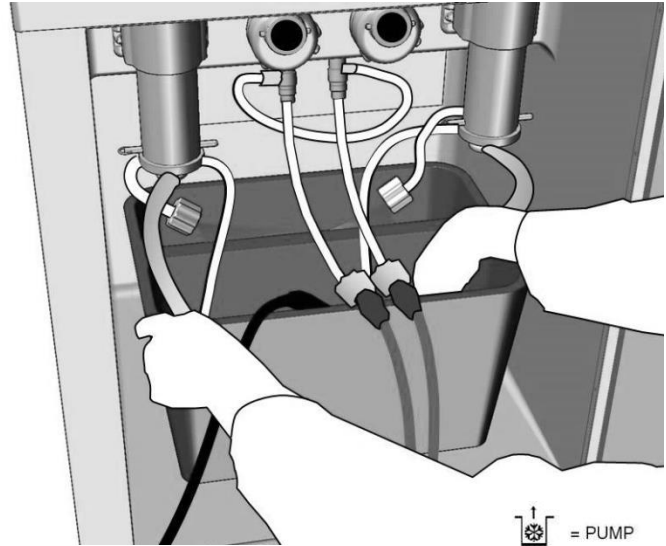

(Image for illustration only) **FIG.34**

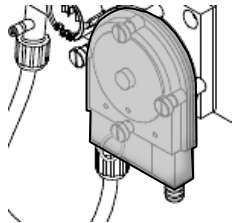

If your soft serve machine is not equipped with a “HORIZON® MIX DELIVERY PUMP”, a few extra steps will be required for the piston pump.

Remove the “PUMP BODY VALVE” **FIG.35** from the “PUMP CYLINDER” and rinse all visible soiling from all surfaces.

Next, aim the “HRWAND128” upward inside the “PUMP CYLINDER”, and rinse the exposed portion of the “PUMP PISTON” with an ample amount of solution.

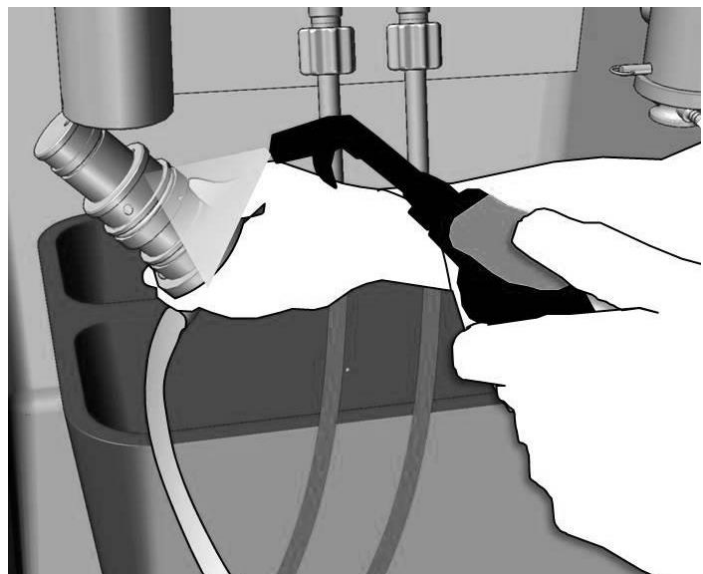

(Image for illustration only) **FIG.35**

Tip: All solution can be easily captured by repositioning the “TWO-BAY CATCH BUCKET”.

Note: Follow Manufactures recommendations for cleaning and servicing the “HORIZON® MIX DELIVERY PUMP” product tubing.

Section 14: Details of the Hydra Rinse® Process

● PRE-CLEAN PISTON PUMP CHECK VALVE(S):



Next, separate the "MIX INLET ELBOW" from the "PUMP BODY VALVE" **FIG.36**. Give the "BLACK RUBBER POPPET" and "SPRING" a thorough rinsing of solution as illustrated.

Once you've completed the cleaning of the "PUMP BODY VALVE", "MIX INLET ELBOW", "BLACK RUBBER POPPET" and "SPRING", re-assemble the pump for sanitizing, which will follow shortly.

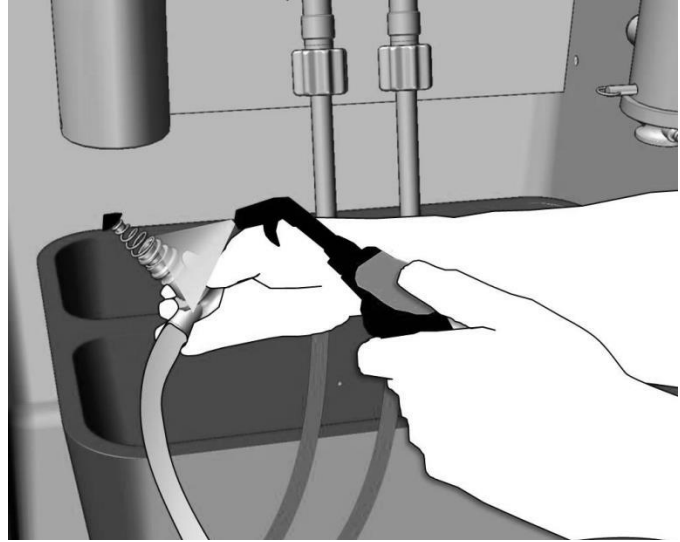

(Image for illustration only) **FIG.36**

● CLEAN SUCTION TUBE ADAPTOR(S) DUCK BILL CHECK VALVE:



If your machine has a product mix adaptor connected to the end of the product mix tube(s), then most likely the adaptor has a "DUCK BILL CHECK VALVE".

Remove the "DUCK BILL CHECK VALVE" **FIG.37**, and clean off all visible soiling. Do not immediately replace the duck bill check valve(s) after cleaning; put aside until the sanitize step has been completed.

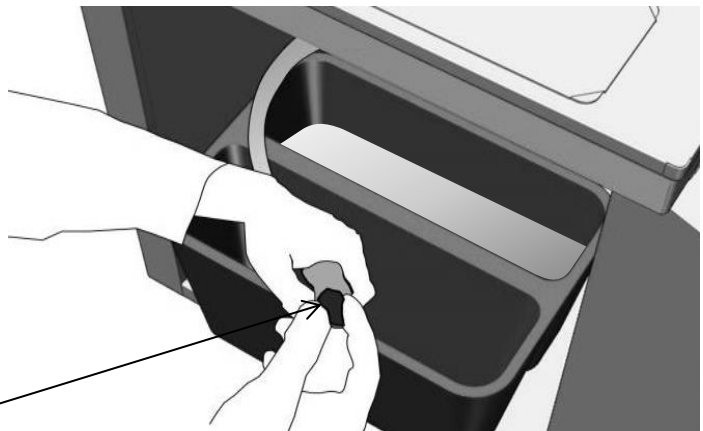

Duck Bill Check Valve

(Image for illustration only) **FIG.37**

Note: In some cases, you may need to separate the product mix adaptor from the product mix tubing to gain access to the "DUCK BILL CHECK VALVE".

Section 14: Details of the Hydra Rinse® Process

● EMPTY TWO-BAY CATCH BUCKET:

Remove the grey water from the "TWO-BAY CATCH BUCKET" **FIG.38**, followed by a good cleaning/sanitizing with the "HRWAND128" and "HYDRA RINSE® WIPES". The bucket will be repurposed to collect the drained sanitizing solution from the freezer barrel(s); the solution will be used for the final sanitizing of the lower product mix delivery system.

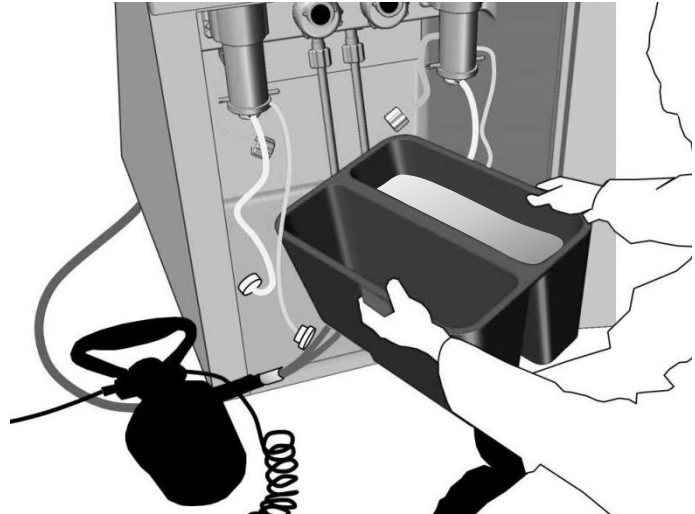

(Image for illustration only) **FIG.38**

● ANCILLARY COMPONENTS:

While the "PRO-CONTROL MODULE CYCLE" is running for approximately 7 minutes, all previously removed components can be broken down for cleaning and sanitizing.

The "HRWAND128" can be used to dispense sanitizer/cleaner solution for all ancillary components **FIG.39**; there's no need to manually mix cleaner or sanitizer solution.

After components are deemed soil free, apply one last application of sanitizer/cleaner solution: no rinsing

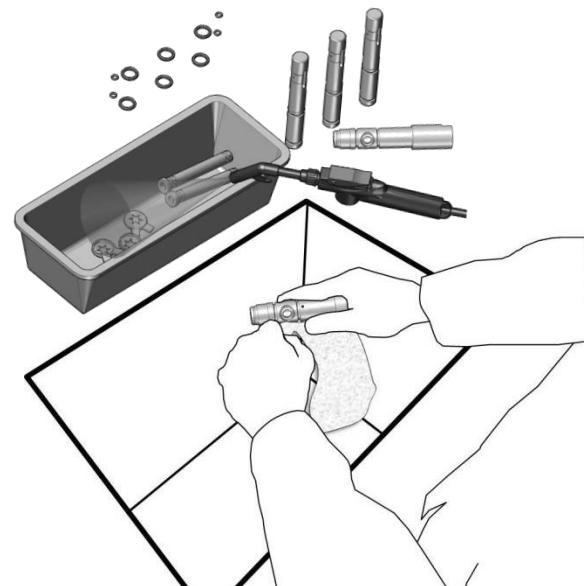

(Image for illustration only) **FIG.39**

Section 14: Details of the Hydra Rinse® Process

● CLEANING AND SANITIZING PRODUCT TANK(S):

The “HRWAND128” and “HYDRA RINSE® WIPES” will aid in giving the “PRODUCT TANK(S)” the attention they need for cleaning and sanitizing.

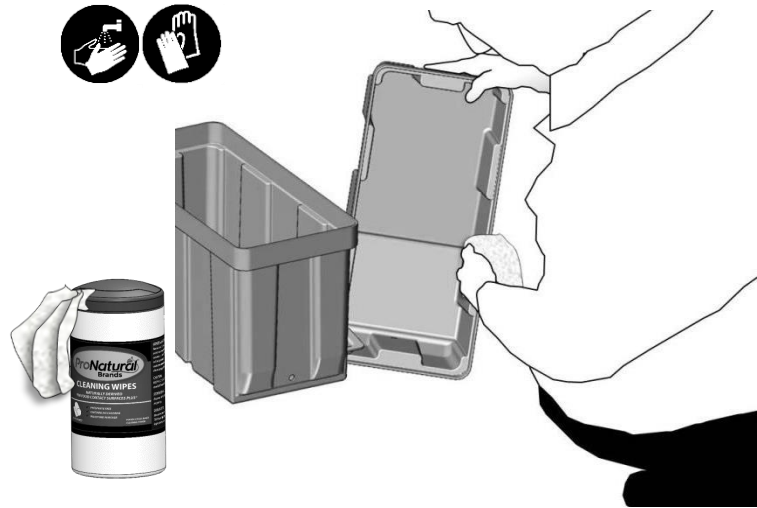

● PRO-CONTROL MODULE CYCLE COMPLETE:

With a steady blinking Green LED on the “USER INTERFACE”: take the soft serve machine out of “WASH MODE”, press and then release the “PLAY/PAUSE” button to conclude the Pro-control Module cycle; removal of the “PRO-CONTROL MODULE” coming up.

With the two-bay catch bucket below the unit (bucket could be left on the floor): Remove the “CLEANER CUP HOUSING”, left side. Open a prime plug to break the vacuum lock; this is required to drain the freezer barrel(s) as illustrated **FIG.41**.

Disconnect the “WATER SUPPLY” from the “PRO-CONTROL MODULE”. Replace the cup housing. Slide the “KEEPER SWITCH” backward into the neutral position; remove the Pro-control Module from the soft serve machine.

Note: When draining seems complete (~1 minute), momentarily placing the soft serve machine in “WASH MODE” to help remove any remaining solution from the freezer barrel(s).

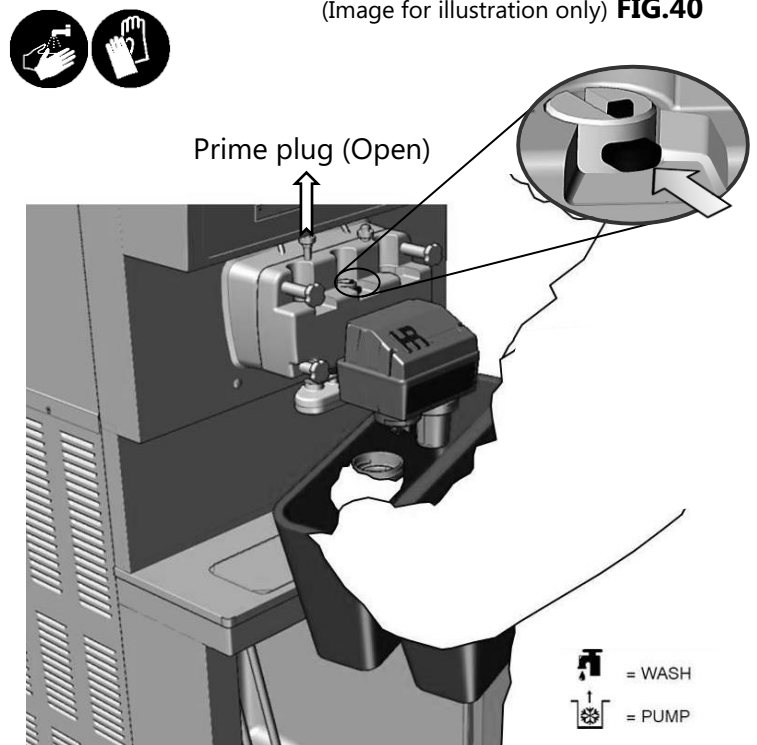

(Image for illustration only) **FIG.40**

(Image for illustration only) **FIG.41**

Tip: To simplify the removal of the “PRO-CONTROL MODULE”: Simply wiggle the unit back and forth while pressing downward on the ends of the “Pro-control Module”.

Section 14: Details of the Hydra Rinse® Process

○ SANITIZE THE LOWER PRODUCT DELIVERY SYSTEM:

Take the “TWO-BAY CATCH BUCKET” with the drained sanitizing solution and place it back into the lower refrigeration cabinet.

Remove the “BYPASS SYSTEM” from the soft serve machine, and carefully drain it into the open/empty bay of the bucket.

The sanitizing of the lower product mix delivery system will be just like the cleaning portion of this process with one exception: we’ll be using the drained sanitizer from the freezer barrel(s) instead of filling the bucket with the “HRWAND128”.

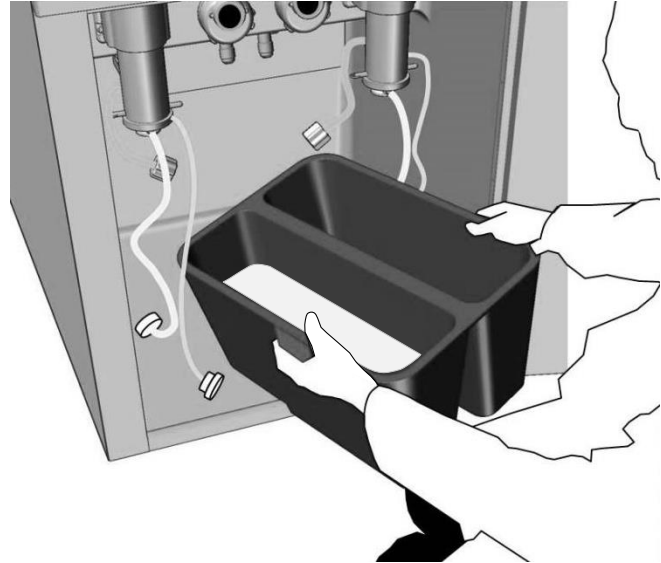

(Image for illustration only) **FIG.42**

Note: Remember to periodically test drained LEXX™ (**Appendix B**).



With all hoses properly re-positioned within the “TWO-BAY CATCH BUCKET” **FIG.43**, activate the “PUMP(S)”. The previously drained sanitizing solution will now be drawn from the front bay, pumped through the product mix delivery system, and captured by the open/empty back bay.

Once most of the solution has traveled through the lower delivery system, de-activate the pump(s). The sanitizing of the lower product delivery system is now complete.

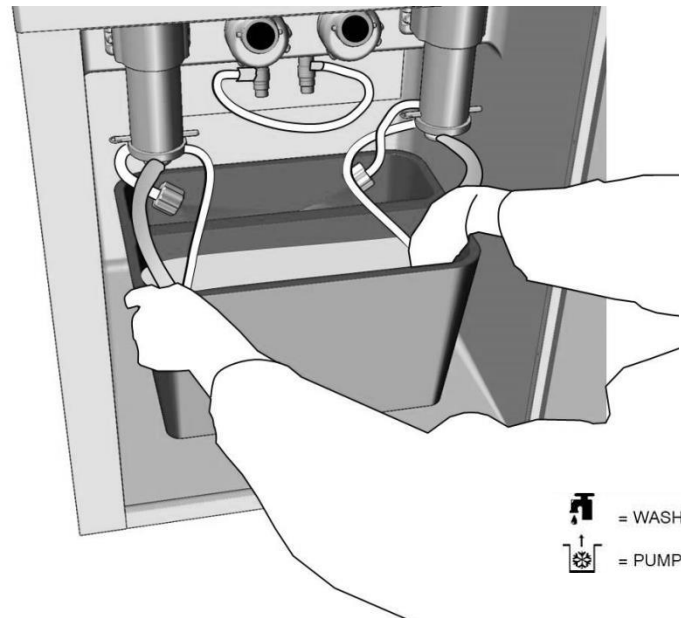

(Image for illustration only) **FIG.43**

Section 14: Details of the Hydra Rinse® Process

● CLEAN AND LUBE DIAPHRAGMS:

Remove the "PRESSURE SWITCH HOUSING(S)". Clean and lube all diaphragms **FIG.44** with food safe lubricant according to manufactures recommendation; reinstall. This is a good time to change gloves after working with lubricant

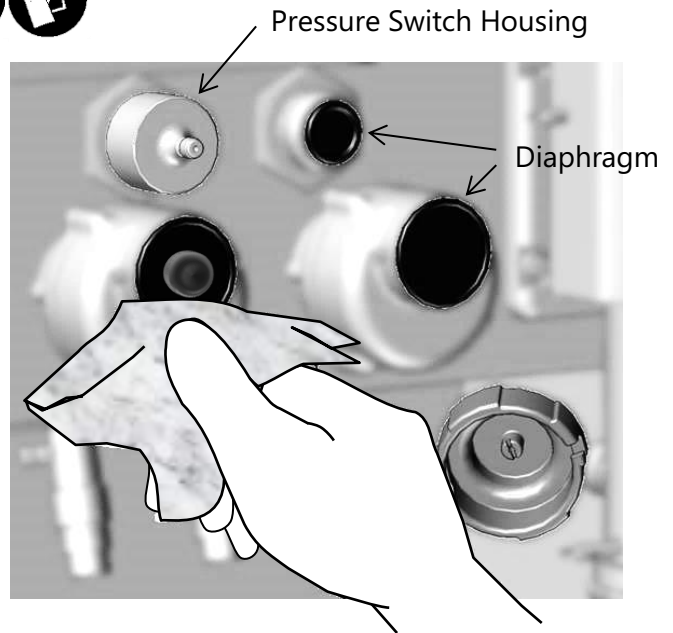
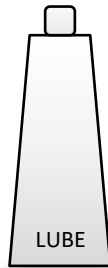

(Image for illustration only) **FIG.44**

Note: Product mix can periodically contact the pressure and mix level diaphragms, so take care to periodically clean and sanitize them on a regular basis.

● FREEZER DOOR AND PRIME PLUG(S):

It's time for a thorough cleaning and scrubbing of the "DRAW VALVE PORT(S)" and "PRIME PLUG PORT(S)" **FIG.45**. If you have the re-designed removable prime plug(s), remove them, and run a barrel brush through the entire prime plug port(s). If prime plug is not removable, flush port(s) with the "HRWAND128" in conjunction with using OEM barrel brush.

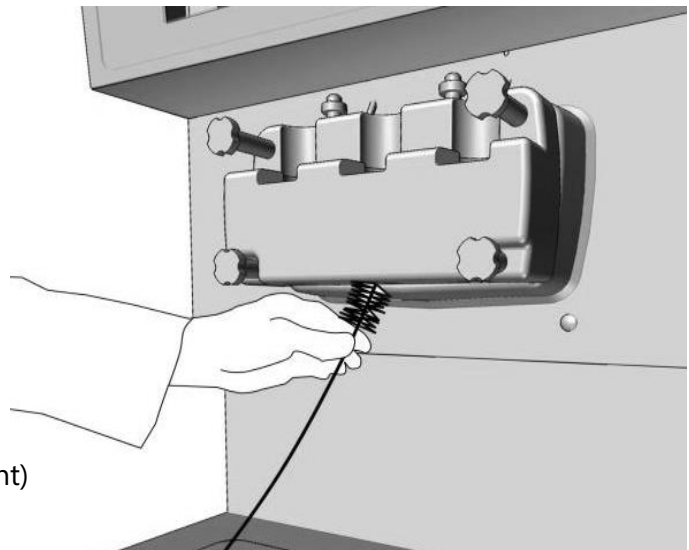
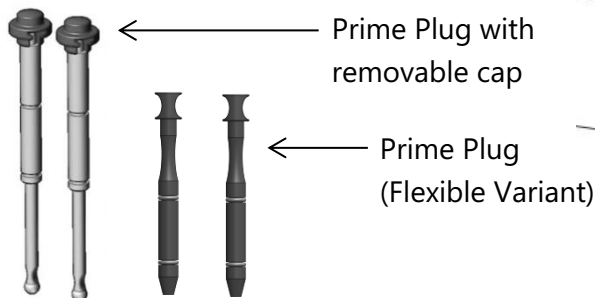

(Images for illustration only) **FIG.45**

Note: Use OEM barrel brushes for mechanical scrubbing of all freezer door port(s).

Section 14: Details of the Hydra Rinse® Process

● MACHINE RE-ASSEMBLY:

Take care when re-assembling the soft serve machine to ensure that you are not re-introducing any contaminants while handling the components; this is a good time to refresh your gloves! Prior to re-assembly of the freezer door, use an OEM barrel brush and give the draw valve port(s) a good mechanical scrubbing; this also applies to the prime plug port(s) if present. Adequately flush all mechanically scrubbed surfaces with the Wand and then precede to re-assembly the front freezer door.

Refer to our online library of instruction videos www.hydrarinse.com for more information on performing this process.

This concludes the cleaning and sanitizing of the soft serve machine without mechanical scrubbing of the internal components.

Tip: Use the “HRWAND128” to keep things wet during re-assembly! This will ensure sanitization while handling components, which also provides lubrication for the Lubeless O-rings during re-insertion!

● MACHINE TEARDOWN FOR MECHANICAL SCRUBBING OF INTERNAL COMPONENTS:

The “PRO-CONTROL MODULE” has a special function that enables the end user to pause the cleaning and sanitizing cycle for mechanical scrubbing. This function will be described next, “SEQUENCE FOR MECHANICAL SCRUBBING INTERNAL COMPONENTS”.

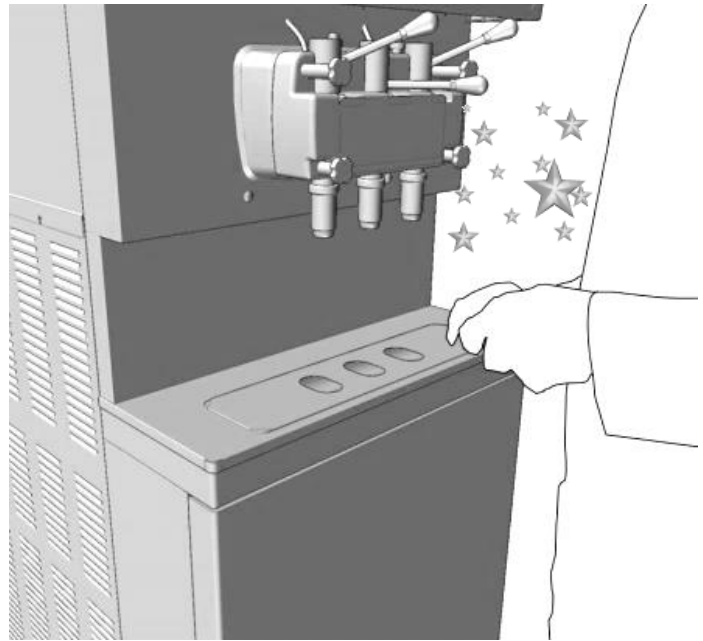

(Image for illustration only) **FIG.46**

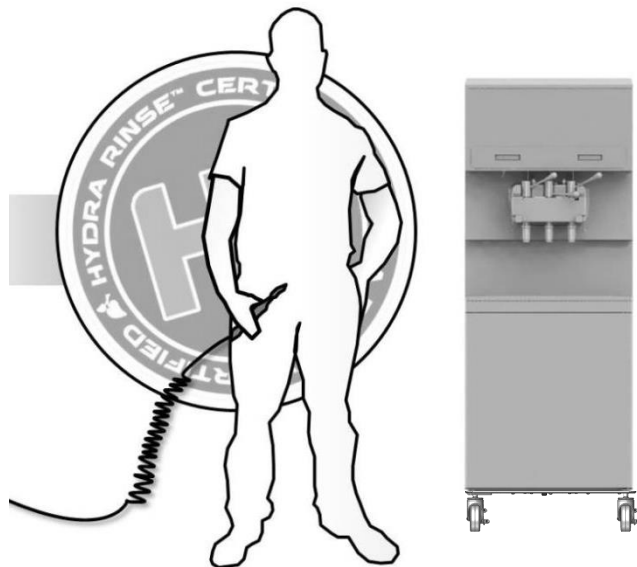

(Image for illustration only) **FIG.47**

Section 14: Details of the Hydra Rinse® Process

↓ SEQUENCE FOR MECHANICAL SCRUBBING INTERNAL COMPONENTS ↓

★ PAUSING THE PRO-CONTROL MODULE:

Roughly 3.5 minutes into the 7-minute cycle, the "PRO-CONTROL MODULE" will sequentially "BEEP" for 15 seconds while all three LEDs "BLINK" simultaneously.

During this sequence press and then release the "PLAY/PAUSE" button to suspend the cycle indefinitely, allowing for machine teardown and mechanical scrubbing.

Once in pause mode, the "GREEN LED" on the "USER INTERFACE" will blink, and a "BEEP" will sound once every 30 seconds until the "PLAY/PAUSE" button is once again pressed and then released to resume the cycle.

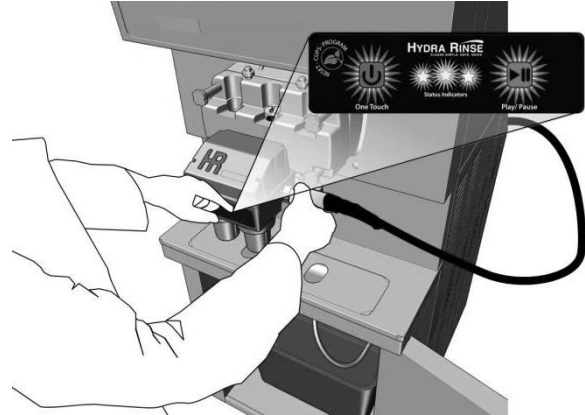

(Image for illustration only) **FIG.48**

Warning: The sanitizer cup solution has not been dispensed yet so do not remove it.

★ SCRUBBING INTERNAL COMPONENTS:

Power down the soft serve machine, "DRAIN SOLUTION", "DISCONNECT WATER SUPPLY" and remove the "PRO-CONTROL MODULE" (page 31).

Once the "FREEZER DOOR" is removed from the machine: Use the applicable brushes that were supplied with the OEM soft serve machine for mechanical scrubbing of all components and internal surfaces; including "PRIME PLUG(S)" if applicable. Use the HRWAND128 for dispensing sanitizer/cleaner solution instead of using a 3-bay sink.

Once the components are deemed soil free, apply one last application of sanitizer/cleaner solution; **no rinsing** required.

Re-install "INTERNAL COMPONENTS", "FREEZER DOOR" and all respective "EXTERNAL COMPONENTS"

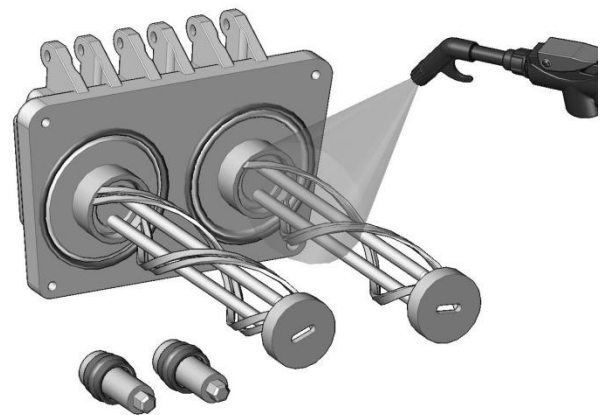

(Image for illustration only) **FIG.49**

Note: Lube is required on "BEATER SHAFT" only before re-assembly (page 12 **FIG.F**).

Section 14: Details of the Hydra Rinse® Process

★ RE-INSTALL PRO-CONTROL

MODULE:

The "PRO-CONTROL MODULE" is currently in pause mode, so take care not to press any buttons on the "USER INTERFACE" while re-installing.

To assist with installing the "PRO-CONTROL MODULE", wet the O-rings on the pistons with either a "HYDRA RINSE® WIPE" or with sanitizer/cleaner solution.

Simply use the "CENTER PISTON" to guide the unit up into the "CENTER DRAW VALVE PORT"; once the piston O-rings begin to contact the "DRAW VALVE PORT(S)", gently wiggle the unit while pushing upward on the ends of the underside of the "INTERFACE MANIFOLD ASSEMBLY".

On the top of the "CENTER PISTON" is the "KEEPER SWITCH". The "PRO-CONTROL MODULE" is in position when the "KEEPER SWITCH" can freely slide forward, securing the unit into place.

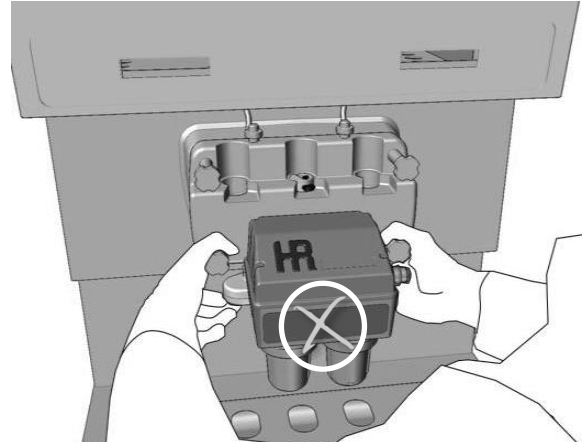

(Image for illustration only) **FIG.50**

★ RESUME CYCLE:

"RE-ATTACH WATER SUPPLY" and the "BYPASS SYSTEM" if for any reason you needed to remove it. Run through your Pro-control Module readiness checklist. Press and then release the "PLAY/PAUSE" button to resume the cycle **FIG.51**. Place soft serve machine back into "Wash mode" for each freezer barrel.

Note: All three LEDs will blink simultaneously on initial resumption of the cycle for approximately 20-30 seconds; sanitizer injection follows shortly thereafter.

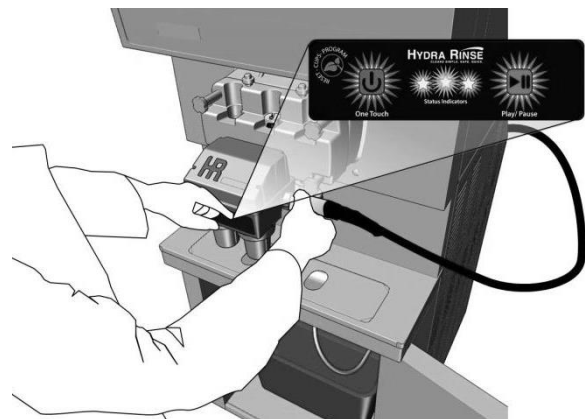

(Image for illustration only) **FIG.51**

↑ SEQUENCE FOR MECHANICAL SCRUBBING CONCLUDED ↑

Section 14: Details of the Hydra Rinse® Process

UTILITY ITEMS:

When cleaning and sanitizing all utility items like waste catch buckets and OEM brushes; remember to integrate the “HRWAND128” and “HYDRA RINSE® WIPES” into all pre-established cleaning protocols for time savings and operator efficiency.



Tip: The HRWAND128 sanitizer/cleaner solution can also be applied to any non-porous hard food contact surface i.e., floors, food prep areas/counter tops, etc.

FINAL STEPS:

“BYPASS TUBE(S)” and the “HYDRA RINSE® PRO-CONTROL MODULE” will always require periodic cleaning and sanitizing.



(Image for illustration only) **FIG.52**

The “BYPASS TUBE(S)” is easily removable from the “BYPASS SYSTEM” for manual scrubbing; from time to time, clean and sanitize before stowing. Remember to remove the “MAGNETIC SPLASH GUARD”, and thoroughly wash down the lower refrigeration cabinet.

The “PRO-CONTROL MODULE” has a “SELF-RINSE CYCLE”: To initiate, connect “WATER SOURCE” and ensure it’s on. Press the “ONE TOUCH” and the “PLAY/PAUSE” buttons simultaneously and hold for ~5 seconds.

All three LEDs (Green, Yellow, and Red) on the “USER INTERFACE” will illuminate indicating that the “SELF-RINSE CYCLE” has commenced; release buttons.

Hold unit over a drain source or catch bucket while flushing is in process.

Tip: Wipe the “PRO-CONTROL MODULE” with “HYDRA RINSE® WIPES” while water is flowing from the unit to adequately clean all surfaces.



(Image for illustration only) **FIG.53**

Note: If the Green LED on the “USER INTERFACE” is still blinking, which indicates that the “PRO-CONTROL MODULE CYCLE” has successfully completed a cycle, the “PLAY/PAUSE” button will need to be pressed and then released prior to entering the “SELF-RINSE CYCLE”; cycle is approximately 30 seconds in duration (repeat as many times as deemed necessary).

Section 14: Details of the Hydra Rinse® Process

● CLEANUP AND STORAGE

SUGGESTIONS:

After removal of the "BYPASS SYSTEM" and re-assembly of the soft serve machine e.g., "DRAW VALVE(S)", "DRAW VALVE HANDLE(S)", "PRIME PLUG(S)" and "DESIGN CAP(S)" if applicable:

Re-introduce product mix into the machine as soon as possible. If intentions are to leave the machine empty for more than 72 hours, you will be required to power off the soft serve machine, remove the "FREEZER DOOR" and disassemble all internal components, allowing them to air dry; this is usually the case for end of season storage of the soft serve machine. Re-install "MIX TANK COVER(S)" if applicable.

Wipe down "FRONT DRIP TRAY" and inspect all "DRIP PAN(S)" for cleanliness; give the machine a good wiping down too.

Stow the "25' BYPASS SYSTEM DRAIN HOSE", "WATER SUPPLY HOSE" and the "PRO-CONTROL MODULE" in a clean, dry place having a temperature range no less than 60°F (15.5°C) and no greater than 90°F (32°C).

As mentioned, "TOKEN TAG" registration is a onetime event for every box of "LEXX™ CUPS" or "LEXX™ MEASURE & POUR BOTTLE(S)"; it's not required prior to every "PRO-CONTROL MODULE CYCLE". Keep the "TOKEN TAG", and do not dispose of it; you can use a previously registered "TOKEN TAG" to read out the number of remaining cycles residing in the "PRO-CONTROL MODULE".

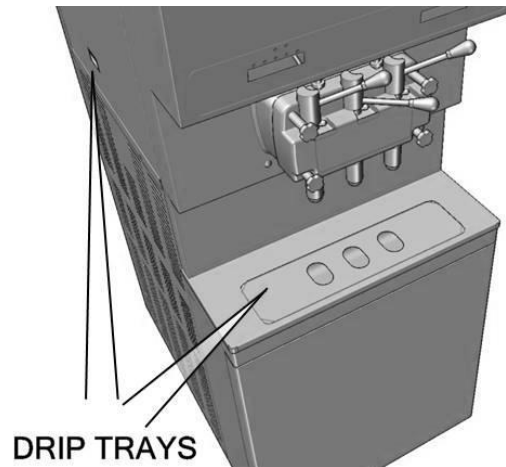

(Image for illustration only) **FIG.54**



Warning: Though our devices are engineered to the highest standard, it is recommended at the end of every day that the water source supplied to the "HRWAND128" and the "PRO-CONTROL MODULE" is turned off; connections are not intended for permanent installation. Leaving the devices under constant static pressure could result in unwanted water damage or flooding.

Tip: After every cycle, remember to remove the LEXX™ cups. Keep the "CUP HOUSINGS" backed off as illustrated **FIG.55**. This will reduce the force required to remove the cup housings between usages.



(Image for illustration only) **FIG.55**

Section 15: Troubleshooting Guide 1 of 2

● Due to the sensitive nature of the “PRO-CONTROL MODULE”; always consult your local authorized Dealer/Reseller when an issue is unresolved.

Refer to the “HRWAND128” Operators Manual for detailed and troubleshooting reference material regarding its practical operation.

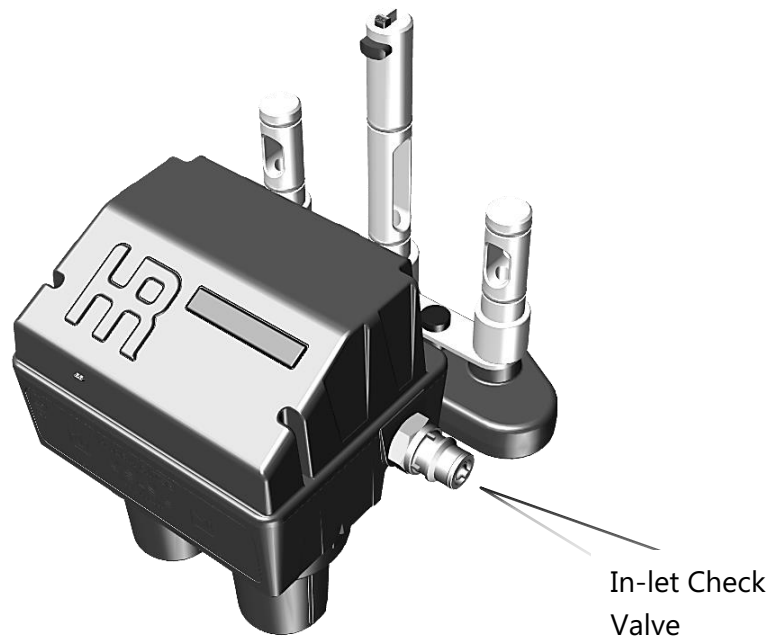

Issue:	Potential Cause:	Potential Solution:
Cycle won't start; Red LED blinks fast, Green and Yellow LEDs on.	<ul style="list-style-type: none"> • The unit has no cycles left 	<ul style="list-style-type: none"> • Need to register a new token tag • “RESET-CUP-PROGRAM” button will need to be pressed to exit error
Red LED blinks slow, unit beeps every 15 seconds	<ul style="list-style-type: none"> • Batteries are at end of life 	<ul style="list-style-type: none"> • Install new batteries. • “RESET-CUP-PROGRAM” button will need to be pressed to exit error.
Cycle started, no water flowing, but water is connected and turned on	<ul style="list-style-type: none"> • Extended period of time that the unit has been sitting 	<ul style="list-style-type: none"> • Refer to Appendix B • Contact your local Hydra Rinse® Distributor/Reseller for more information
Unit will not power up	<ul style="list-style-type: none"> • Check that batteries are correctly installed • Corrosion on battery terminals 	<ul style="list-style-type: none"> • Check and/or re-install batteries as required for proper operation • Contact local Distributor/Dealer for replacement
Water lines leak	<ul style="list-style-type: none"> • Improper engagement of push-to-connect to hose • Loosely connected fittings 	<ul style="list-style-type: none"> • Check and push hose into leaking fitting • Tighten leaking fitting an additional, not to exceed 90-110° rotation

TABLE CONTINUED →

Section 15: Troubleshooting Guide 2 of 2

Issue:	Potential Cause:	Potential Solution:
Cup housing(s) are hard to tighten	<ul style="list-style-type: none"> Worn or no food safe lube present 	<ul style="list-style-type: none"> Re-lube with food safe lube, replace O-ring(s) if problem unresolved
Cup housing(s) leak	<ul style="list-style-type: none"> Ensure cups are properly engaged with the Pro-control Module housing 	<ul style="list-style-type: none"> Replace O-ring(s)
Bypass Tube won't stay in Mix Inlet Hole	<ul style="list-style-type: none"> O-ring(s) worn Food safe lube present Frozen mix left in Freezer Barrel(s) Blocked discharge hose 	<ul style="list-style-type: none"> Replace O-ring(s) All Lube must be removed Never perform cycle with frozen mix Ensure no kinks or blockages in hose
Quick connects leak	<ul style="list-style-type: none"> Worn out, O-ring damaged 	<ul style="list-style-type: none"> Contact local Distributor/Dealer for replacement parts/ O-ring

Section 16: Pro-control Module LEDs 1 of 2

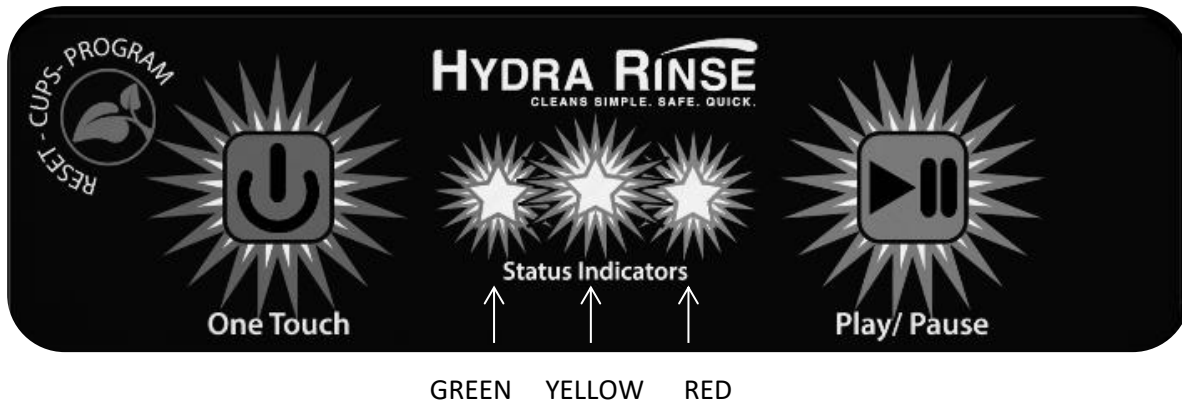

LEDs are the communication portal between end users and the Pro-control Module. Here's a few to understand: (Status Indicators from Left to Right: Green, Yellow, Red)

= LED Blink,
 = LED On,
 = LED Off,
 S = Slow, F = Fast, (1st, 2nd, 3rd) = Order of Blink

PROCESS CODES:					
<u>GREEN</u> Hundreds	<u>YELLOW</u> Tens	<u>RED</u> Ones	<u>BEEP</u>	<u>DESCRIPTION</u>	<u>ACTION</u>
			-	Pro-control Module "Power ON"	-
			-	Pro-control Module "Processing"	-
F			Every 30 seconds Double Beep	Pro-control Module "Pause Mode"	Press "PLAY/PAUSE" to resume cleaning sequence
S			-	Pro-control Module has completed a successful cycle	Press "PLAY/PAUSE" to conclude cycle
1 st	2 nd	3 rd	-	Left to Right LED sequence: Indicates Pro-control Module is in "Cleaning" Mode	-
1 st	2 nd	1 st	10 consecutive beeps	Inward LED sequence: Indicates Pro-control Module is in "Agitate Solution" Mode Inward LED sequence: Indicates Pro-control Module is in "Agitate Solution" Mode	Place Soft Serve Machine in "Wash Mode" reminder

TABLE CONTINUED →

Section 16: Pro-control Module LEDs 2 of 2

= LED Blink,
 = LED On,
 = LED Off,
 S = Slow, F = Fast, (1st, 2nd, 3rd) = Order of Blink

PROCESS CODES CONTINUED:					
<u>GREEN</u> Hundreds	<u>YELLOW</u> Tens	<u>RED</u> Ones	<u>BEEP</u>	<u>DESCRIPTION</u>	<u>ACTION</u>
			15 consecutive beeps	All LEDs Flash simultaneously: 20 seconds to halt cycle for full teardown All LEDs Flash simultaneously: End user pressed "PLAY/PAUSE" button resuming cycle after teardown	Press and then release the "PLAY/PAUSE" button Allow cycle to complete
3 rd	2 nd	1 st	-	Right to Left LED sequence: Indicates Pro-control Module is in "Sanitizing Mode"	-
ERROR CODES:					
		F	Pulse Beep	No Tokens. End user pressed the "ONE TOUCH" button or registered an empty token tag with zero tokens loaded in unit	Register Token Tag with Pro-control Module (Section 7)
		F	-	End user pressed the "ONE TOUCH" button, Pro-control Module is not programmed with a cleaning cycle script	CONTACT Dealer/Reseller
		S	Pulse beeps every 15 sec	End user pressed the "ONE TOUCH" button, Battery is below allowable threshold	Replace Battery (Section 17)
		F	Pulse beeps every second	Pro-control Module cannot presently accept any more Token Tag cycles, Tokens were not registered (750 Max Limit met)	Save Token Tag for later use. Press and then Release the "RESET-CUPS-PROGRAM" button
For Pro-Control Modules with firmware version pre-3.0:					
			-	No tokens. End User Checked for available token count, and zero tokens loaded in unit	Ensure to register a valid Token Tag. Press and then Release the "RESET-CUPS-PROGRAM" button once for registering and once to reset

Section 17: Battery Installation/Replacement

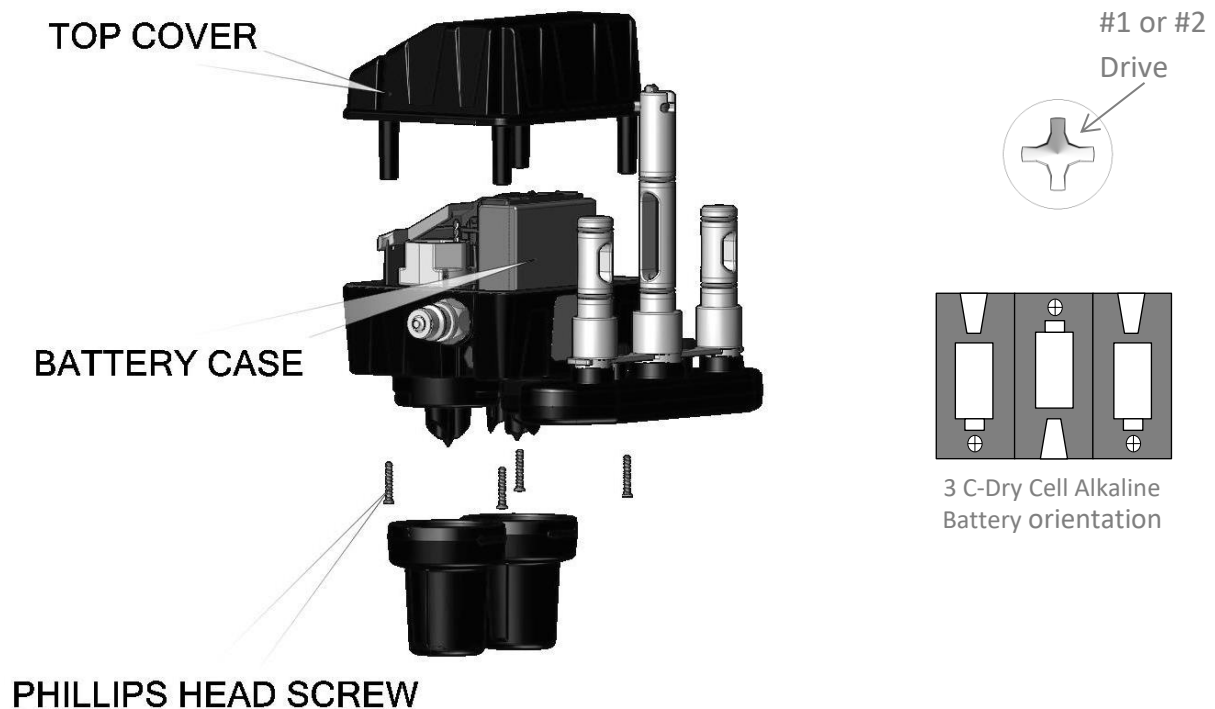

(Image for illustration only) **FIG.33**

To gain access to the "BATTERY CASE":

Note: Before changing the battery(s), remove the Pro-control Module from any areas that may allow water to enter the inner housing compartment.

- Remove both "CUP HOUSINGS" from the "PRO-CONTROL MODULE".
- Remove the 4 "PHILLIPS HEAD SCREWS" that secure the "TOP COVER" to the "PRO-CONTROL MODULE HOUSING". (screws located on the underside of unit)
- Slide open the "BATTERY CASE COVER"; ensure batteries are correctly oriented **FIG.33**
- When replacing "PHILLIPS HEAD SCREWS", tighten in a cross pattern while paying close attention to "TOP COVER" gap. When "TOP COVER" meets the "PRO-CONTROL MODULE HOUSING" (no gap), stop tightening screw; over tightening may stress unit causing premature failure.

Section 18: Online Resources/Support

FOR REPLACEMENT COMPONENTS, ADDITIONAL
INFORMATION, SUPPORT, AND VIDEOS FOR YOUR
HYDRA RINSE® PRODUCTS PLEASE VISIT

WWW.HYDRARINSE.COM

OR CONTACT YOUR LOCAL HYDRA RINSE® DEALER



Section 19: Warranty

The Seller warrants that the **TAYHR** will operate or substantially perform within the published specifications and be free from material and workmanship defects, when subjected to normal, proper, and intended usage by properly trained personnel. Please visit www.hydrarinse.com for warranty registration.

Seller agrees during the Warranty Period, to repair or replace, at Seller's option, defective item(s) to allow the **TAYHR** to operate or substantially perform within the published specifications; provided the Buyer (a) promptly notifies the Seller in writing when the defect is discovered, and provides Seller the product model, serial number and details of the warranty claim; and (b) after Seller's review, Seller will provide Buyer with service data and/or a Return Merchandise Authorization ("RMA"), which may include product-specific handling instructions. At that time, the Buyer may return the defective item(s) to Seller with all return shipping costs paid by Seller. The Seller has the option to use new or refurbished replacement parts for warranty work. All replaced parts become the property of Seller. Shipment to Buyer of repaired or replacement parts/equipment will be made in accordance with the Seller's delivery policy.

The Seller has no obligation to make repairs, replacements or corrections, in whole or in part, as the result of: (i) normal wear and tear; (ii) accident, disaster or force majeure; (iii) the Buyer's misuse of the **TAYHR** or the Buyer's negligence; (iv) use of the **TAYHR** in a manner for which it was not designed or intended; (v) external causes such as, but not limited to, power failure or electrical power surges; (vi) improper storage or handling of the **TAYHR** by Buyer; or (vii) use of the **TAYHR** in combination with equipment not purchased directly from the Seller.

Any installation, maintenance, repair, service, relocation or alteration, or other tampering with, the **TAYHR** performed by any individual or entity other than the Seller, without Seller's prior written approval, or any use of replacement parts not supplied by Seller, shall immediately void, and cancel this warranty. This warranty entitles you specific rights, and you may also have other rights, which differ from state to state. No other warranties shall apply.

Section 20: Appendix A

LEXX™ pH Solution Measurement ProNatural® Brands pH Test Strip (HR-KT-0054)

Inspection Process:

1. Creating Test Solution:

Hydra Rinse® Pro-control:

After the completion of the Hydra Rinse® Pro-control cycle, drain LEXX™ solution from machine into a clean emptied catch bucket for collecting test solution (do not add used LEXX™ Cups to the drained solution in catch bucket)

Wand:

Allow solution to freely dispense into a catch bucket for a minimum of 30 seconds. Next collect at least 8 fl. oz. of solution into a clean emptied cup for collecting test solution.

2. Taking Measurement:

Submerge test strip (~2 inches in length from roll) in solution for 2 seconds. Compare wetted test strip immediately to the color scale.

3. Results:

Test strip should indicate ≤ 3.5 pH for an acceptable reading when testing with a LEXX™ pH Test Strip.

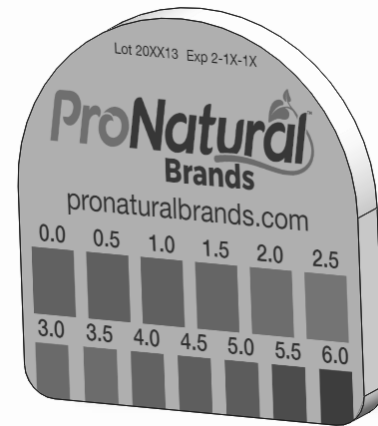

Section 20: Appendix A

LEXX™ Total Acid Concentration (grams/Liter) Semi-quantitative Measurement (Sold separately)

QUANTOFIX® Total acid (Part no. 91353)

Inspection Process:



1. Creating Test Solution:

Hydra Rinse® Pro-control:

After the completion of the Hydra Rinse® Pro-control cycle, drain LEXX™ solution from machine into a clean emptied catch bucket for collecting test solution (do not add used LEXX™ Cups to the drained solution in catch bucket)

Wand:

Allow solution to freely dispense into a catch bucket for a minimum of 30 seconds. Next collect at least 8 fl. oz. of solution into a clean emptied cup for collecting test solution.

2. Taking Measurement:

Follow the instructions supplied with the QUANTOFIX® product to obtain the semi-quantitative total acid content.

3. Results:

Test strip should indicate between:
2.0-2.5 g/L



QUANTOFIX® Total acid

en

Description:
QUANTOFIX® Total acid are test strips for semi-quantitative determination of the total acid content. The total acid content is expressed as g of citric acid per L. QUANTOFIX® Total acid test strips are also suitable for reflectometric evaluation using the QUANTOFIX® Relax (REF 913 46).

Pack content:
1 aluminium can with 100 test strips

Measurement range

Visually

2-5 g/L citric acid

Color gradations:

0 · 2.0 · 2.5 · 3.0 · 4.0

General indic:

Always with

drawal. 1

Instru:

1. 1

2. 2

3. 3

Reflectometrically



Consult your local and state health codes for your requirements

*Recommend purchasing from CTL Scientific. Toll-Free: 888-686-3454

Intentionally Blank

101-1372 E

HYDRA RINSE®
CLEANS SIMPLE. SAFE. QUICK.

Standardizing Innovation

101-1372 E