

Installation
& Operation
Manual

REV. 1223

HUSSMANN[®]/CHINO

VR3-M/F-EP, VR3HV-MF-EP

MEAT/FISH REMOTE

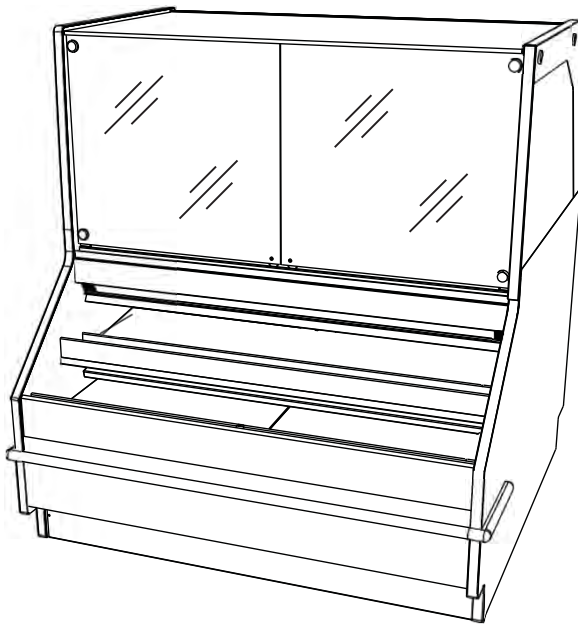

HUSSMANN[®]

**VR3-M/F-EP, VR3HV-MF-EP
MEAT/FISH REMOTE**

Table of Contents

Case Sections	4	User Information	36
Installation	5	Start Up	36
Receiving Case	5	Load Limit	36
Snapping Chalk Lines	5	Basic Operation	36
Placement	6	Merchandising Requirements	37
Lifting and Transport Instructions	7	Merchandising DON'TS	38
VR3 M/F Drain Location	7	Maintenance	39
Lower Body Panel Install	8	Case Cleaning	39
Rear Body Panel Install	8	Exterior Surfaces	39
Levelling Adjustment	9	Cleaning Bumpers	39
Leg Adjustment	9	Cleaning Under Merchandiser	39
Installation (Joint Checksheet)	10	Cleaning Stainless Steel Surfaces	39
Arm Adjustment (HV Only)	11	Interior Surfaces	39
Arm Adjustment(NON-HV)	13	Cleaning Coils	39
Glass Adjustment	15	Recommended Cleaning Schedule	39
Setting and Joining	16	Prop 65 (CA Only)	40
Leveling	16	Troubleshooting	41
Refrigeration	19		
Refrigerant	19		
Refrigerant piping	19		
Line Sizing	19		
Oil Traps	19		
Piping Diagram (General)	20		
Refrigeration Components	21		
Spiral Coil and Gravity Coil	22		
Refrigeration Spec Sheets	23		
Electrical	25		
Merchandiser Electrical Data	25		
Electrical Connections	25		
Field Wiring	25		
Identification of Wiring	25		
Remove Rear Raceway	26		
Wiring Diagram Index	26		
Electrical Conduit (Electrical Box)	26		
Electrical Wiring Diagram	27		

General Information

Case Description: **Refrigerated Service Meat Merchandiser**

Shipping Damage: All equipment should be thoroughly examined for shipping damage before and during unloading. This equipment has been carefully inspected at our factory and the carrier has assumed responsibility for safe arrival. If damaged, either apparent or concealed, claim must be made to the carrier immediately.

Apparent Loss or Damage: If there is an *obvious loss or damage*, it must be noted on the freight bill or express receipt and signed by the carrier's agent; otherwise, carrier may refuse claim. The carrier will supply necessary claim forms.

Concealed Loss or Damage: When loss or damage *is not apparent until after all equipment is uncrated*, a claim for concealed damage is made. Make request in writing to carrier for inspection within 15 days, and retain all packaging. The carrier will supply inspection report and required claim forms.

Shortages: Check your shipment for any possible shortages of material (See Parts List page 11). If a shortage should exist and is found to be the responsibility of Hussmann Chino, notify Hussmann Chino. If such a shortage involves the carrier, *notify the carrier immediately*, and request an inspection. Hussmann Chino will acknowledge shortages within ten days from receipt of equipment.

Hussmann Chino Product Control: The serial number and shipping date of all equipment have been recorded in Hussmann's files for warranty and replacement part purposes. All correspondence pertaining to warranty or parts ordering must include the serial number of each piece of equipment involved, in order to provide the customer with the correct parts.

Location/Store Conditions: The VR3(HV)-M/F-EP refrigerated merchandiser has been designed for use only in air conditioned stores where temperature and humidity are maintained at or below 75°F Dry bulb and 55% relative humidity. **DO NOT** allow air conditioning, electric fans, ovens, open doors or windows (etc.) to create air currents around the merchandiser, as this will impair its correct operation.

Keep this booklet with the case at all times for future reference.

HUSSMANN®/CHINO

A publication of HUSSMANN® Chino

13770 Ramona Avenue • Chino, California 91710

(909) 628-8942 FAX

(909) 590-4910

(800) 592-2060

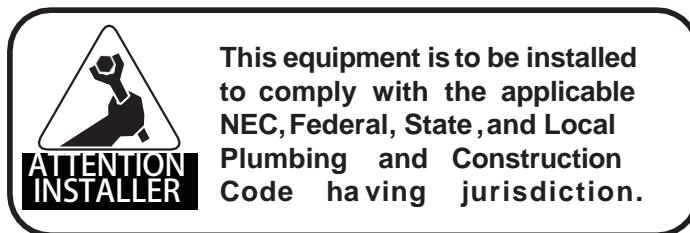

Case Sections

VR3-M/F-EP Vertical Glass Meat
Standard Service Dome, Multi Deck Self Service

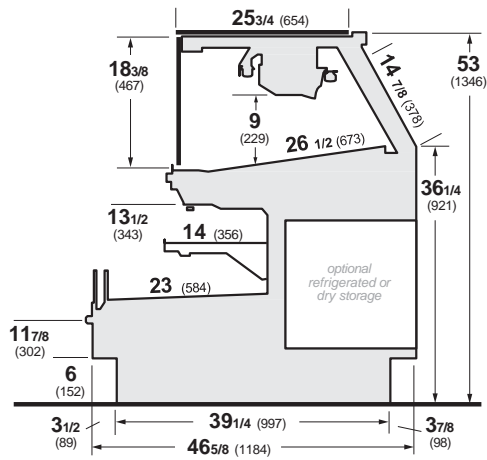

VR3-M/F-EP +2 Vertical Glass Meat
Standard Service Dome, Multi Deck Self Service +2" height

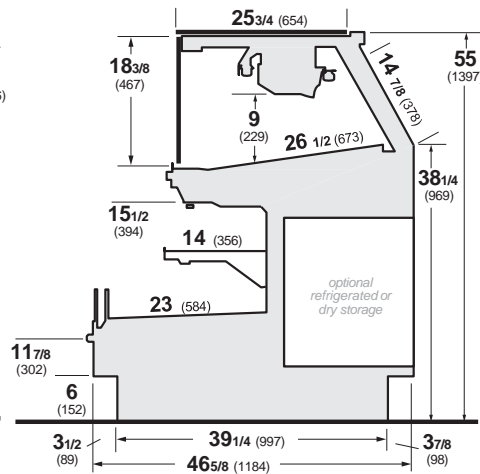

VR3-M/F-EP +4 Vertical Glass Meat
Standard Service Dome, Multi Deck Self Service +4" height

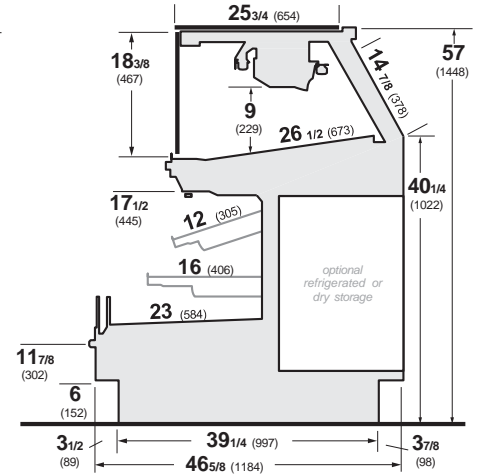

VR3-M/F-EP

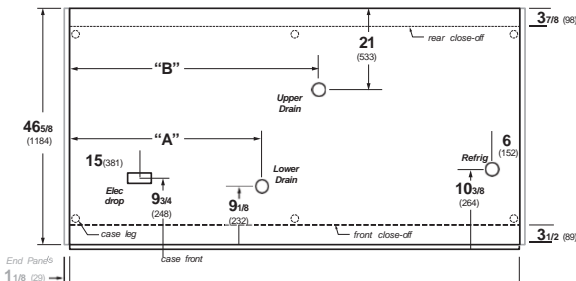

Length	"A"	"B"
4'	7 (178)	32 (813)
6'	41 (1041)	44 (1118)
8'	53 (1346)	56 (1422)
12'	65 (1651)	77 (1956)

VR3HV-M/F-EP

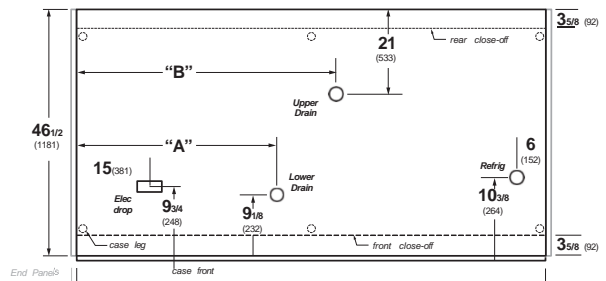

Length	"A"	"B"
4'	7 (178)	32 (813)
6'	41 (1041)	44 (1118)
8'	53 (1346)	56 (1422)
12'	65 (1651)	77 (1956)

VR3HV-M/F-EP Vertical Glass Meat
High Volume Service Dome, Multi Deck Self Service

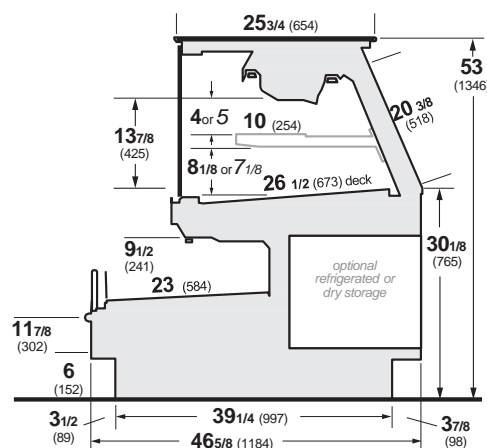

VR3HV-M/F-EP +2 Vertical Glass Meat
High Volume Service Dome, Multi Deck Self Service +2" height

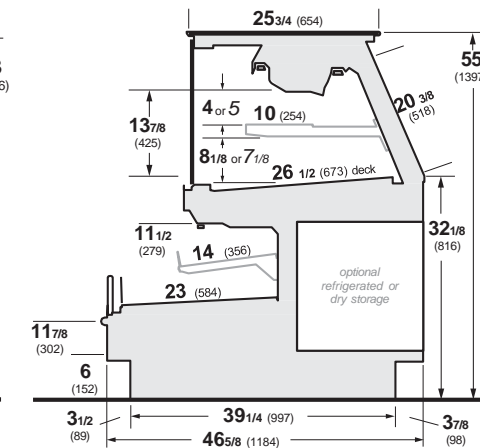

VR3HV-M/F-EP +4 Vertical Glass Meat
High Volume Service Dome, Multi Deck Self Service +4" height

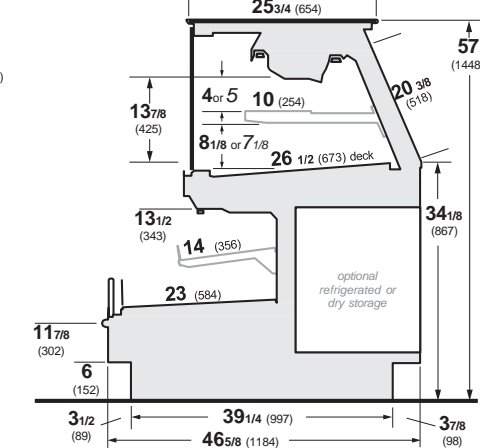

Installation

NOTICE

Do NOT remove Foam Blocks from shelves and glass until the merchandisers are positioned for installation. Shelves or merchandising glass may be damaged.

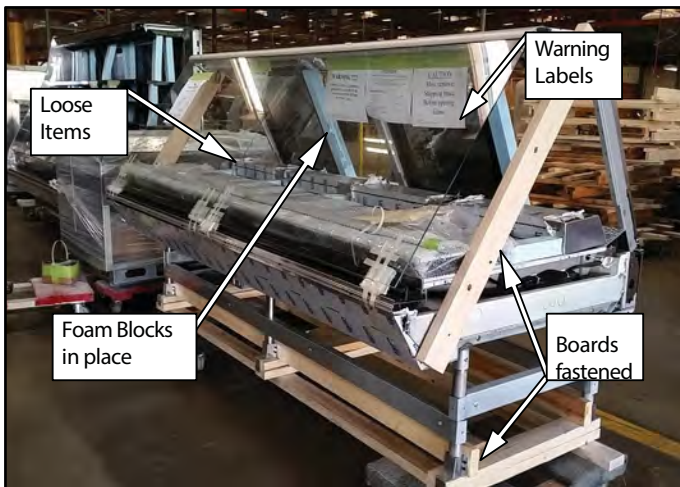

Case is to arrive at store as was shipped from factory. See reference above for proper shipment referencing. (Not actual case)

Receiving Case

Upon receiving your new Hussmann Case all equipment should be thoroughly examined for shipping damage before and during unloading. This equipment has been carefully inspected at our factory. Any claim for loss or damage must be made to the carrier. The carrier will provide any necessary inspection reports/ or claim form.

If there is obvious loss or damage, it must be noted on the freight bill or express receipt and signed by the carrier's agent; otherwise carrier may refuse claim.

Snapping Chalk Lines

Prepare permanent positioning by marking floors with Chalk snap lines where cases are to be located. Chalk lines are to run along the base or legs of cases.

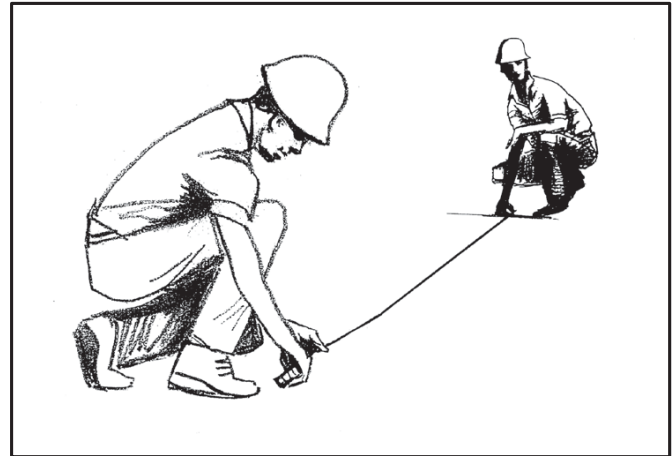

Installation (cont'd)

Placement

Important: See lifting instructions to properly lift case when being placed on dollies or permanent location. (See page 7 for Lifting Instructions.)

Leave all hardware and fittings in place until case is located at or near its preferred location. Using a J-Bar lift the case from the 2x4 boards and placing dollies underneath each Base Leg, proceed to moving the case to its designated location if not done so already.

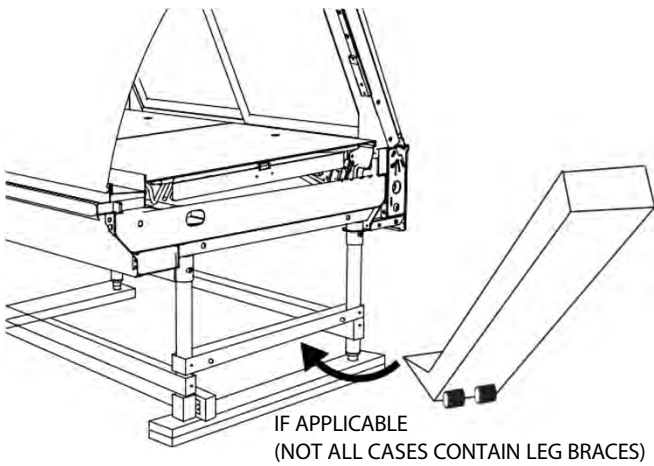

The Illustration Below demonstrates perfect placement of a dolly per 1 side for both Base Legs of the merchandiser.

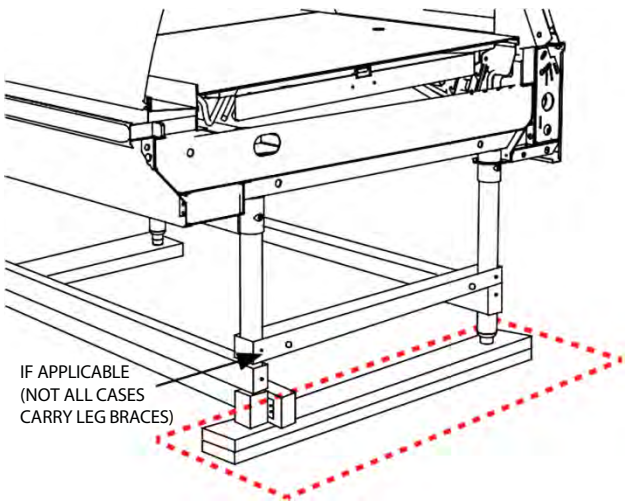

Move the fixture as close as possible to its permanent location and then remove all packaging and prepare to remove off Skid. Remove all separately packed accessories such as kits, and panels. Check for damage before discarding packaging.

Remove screws as well as fastened plates bolted to each 2x4 board at each base leg.

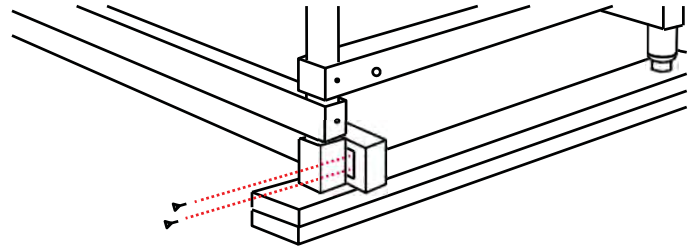

Remove fastened plates only upper Brace Legs are to remain fastened onto case.

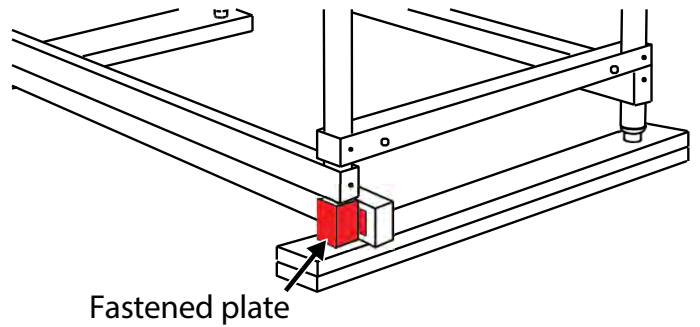

Once the fastened plates are removed a J-Bar can be used to lift at each end of the Leg Braces to remove the below 2x4 boards.

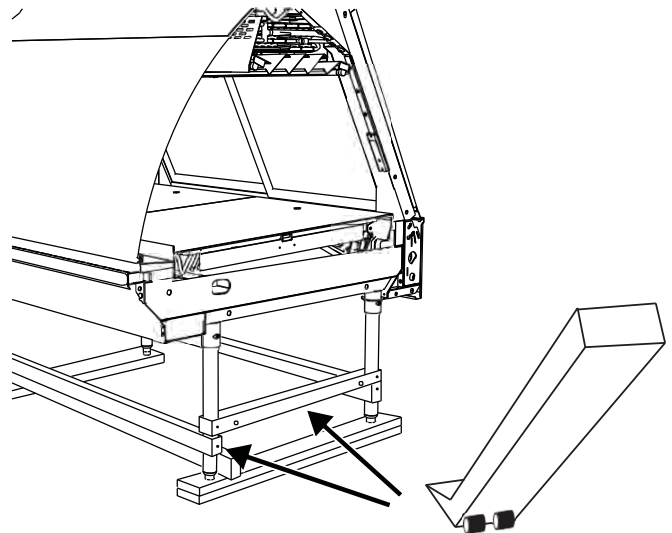

Installation (cont'd)

Lifting and Transport Instructions

1. The VR3 can be lifted by a forklift at typical lifting points.
2. Ensure lower body panels are removed before lifting with a forklift. Serious damage will occur if the body panels are not removed.
3. Make sure that fork spacing and width will not damage drain or come in contact with piping, or electrical lines
4. Be sure that the forks are long enough to support beyond the center of the case but not damage near components. Check for proper balance before moving. A minimum fork length of 36" is recommended for 68" wide cases
5. The VR3 merchandiser can be raised at one end underneath the deck with a forklift to allow the placement of rollers or dollies.
6. Evenly support the entire base structure on rollers or dollies before attempting to move. Each Base Leg must have its own dollie to properly support the case.

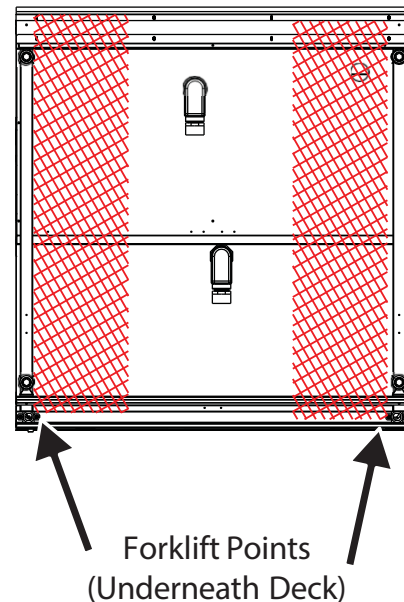

Lifting Points are typical and dependent upon size of case and refrigeration application, drainage configurations will call for alterations in Lifting Zones.

Below are the following drainage configurations and lifting should be altered to the expected model.

VR3 M/F Drain Location

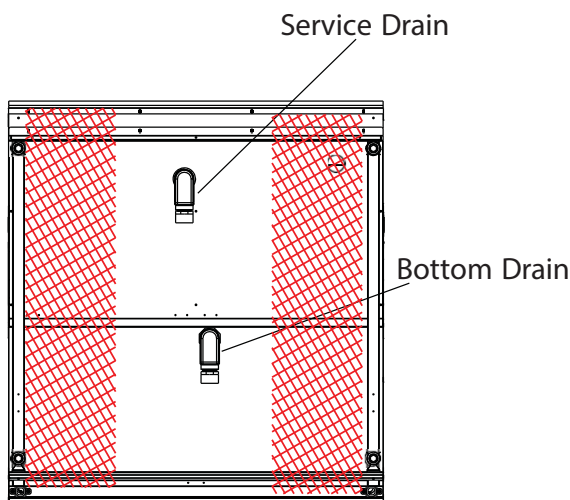

WARNING

Improper placement of forks may damage drainage piping. Use a spotter when placing forks. Make sure that piping will not be damaged. Use J-Bars or Jacks if forks cannot be used safely

Installation (cont'd)

Lower Body Panel Install

No tools will be needed to install body panels.

To begin Bottom panel assembly place the front panel along in front of the case and align the base legs just underneath the lower sections of the case. Snap in spring clips to the base legs of the case.

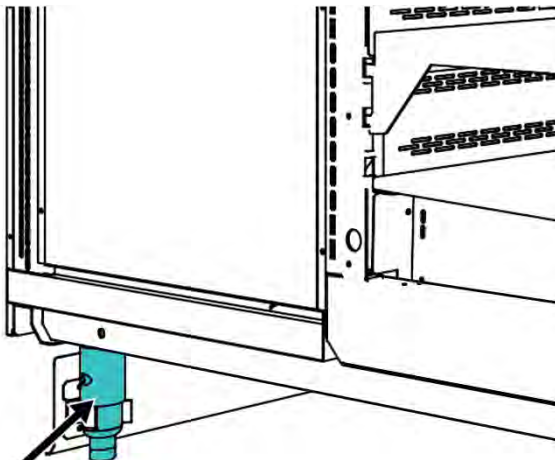
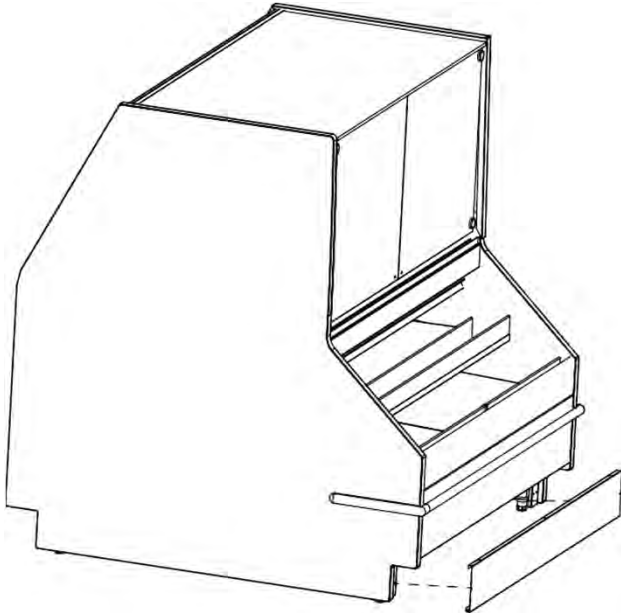

BASE LEG

Rear Body Panel Install

1. Align clips of rear panel to Base Legs of case
2. Secure top and bottom clips of rear panel to Base Legs as shown below.

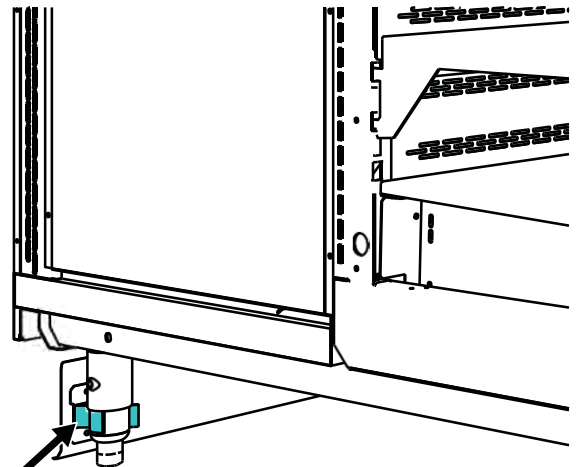
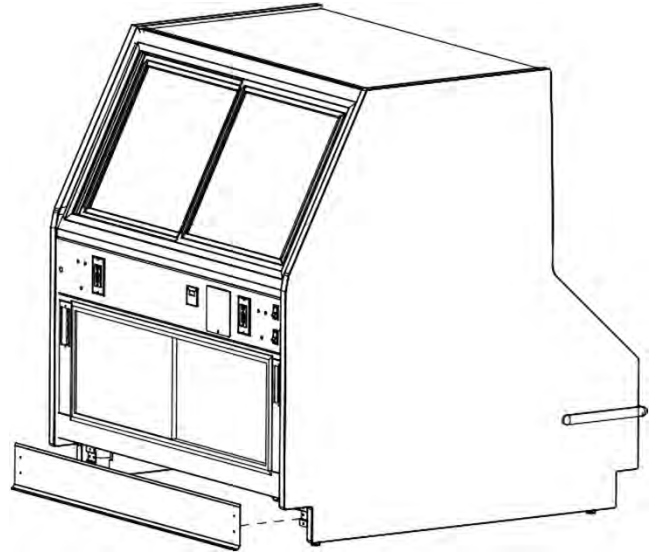

SPRING CLIP

Installation (cont'd)

Levelling Adjustment

Position the case at the highest point. Set a long magnetized level (4ft [1220 mm] or more) on either underneath the deck or on top of the case. Ensure to level case from front to back and side to side.

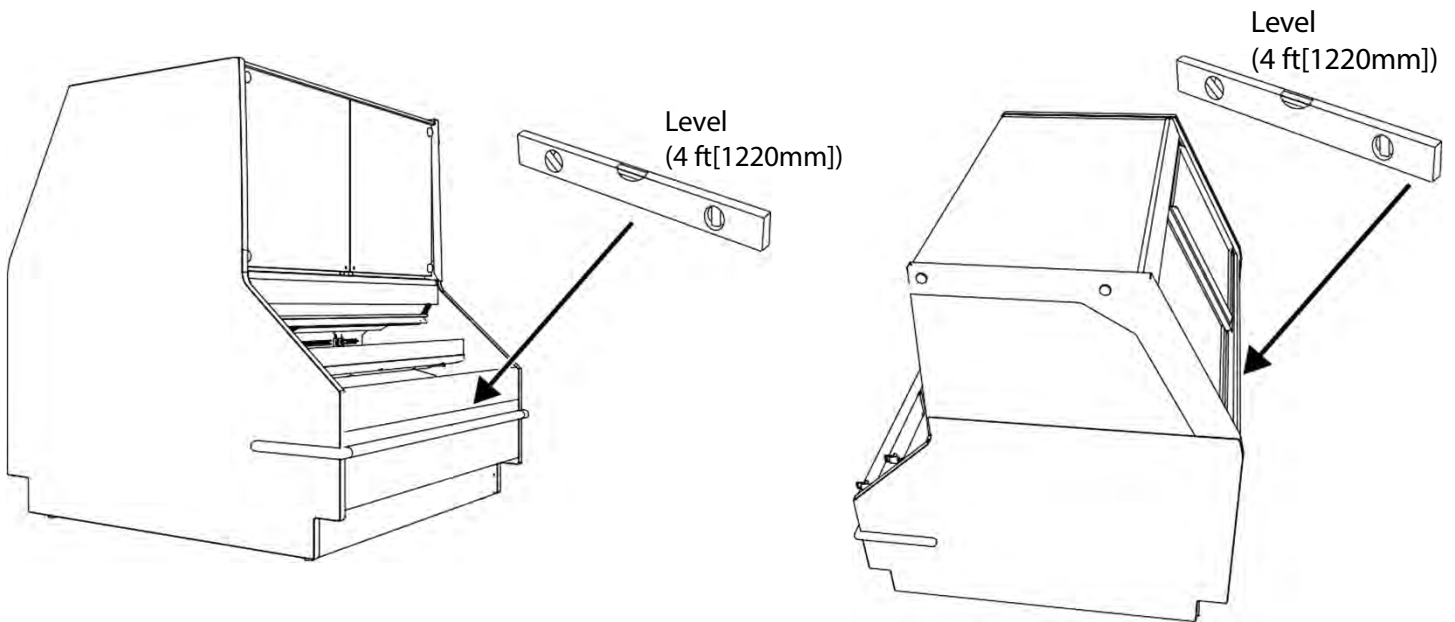

Leg Adjustment

Adjust the legs at each corner of the case to level out any discrepancies in order to optimize case performance and proper drainage.

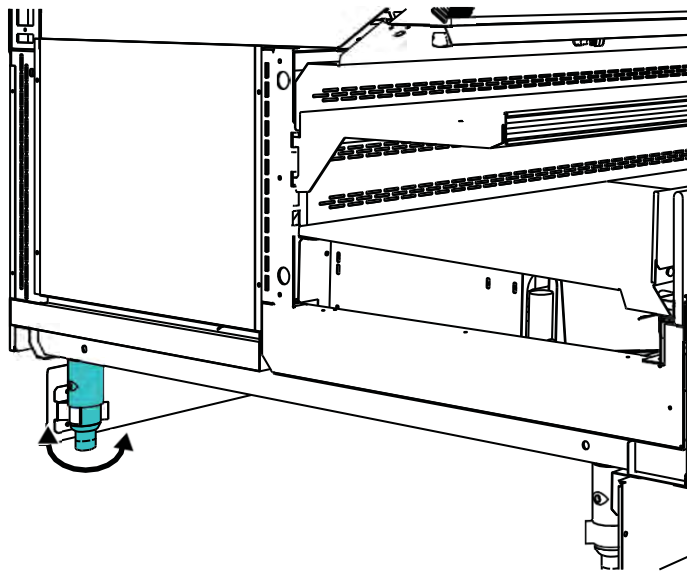

Note: To avoid removing concrete flooring, begin line up levelling from the Highest point of the store floor.

A wrench or pliers may be used to adjust each base leg.

Turning the base of each leg clockwise will raise the height of the case.

Turning the base of each leg counterclockwise will lower the height of the case.

Installation (Joint Checksheet)

VR3HV/VR3/ JOINT CHECKSHEET

*SEE INSTALLATION GUIDE

INSPECTOR _____
 SALES ORDER # _____
 EXT COLOR _____

⬡ INDICATES CASE BOLTING/ALIGNMENT POINT INT FINISH __SS__/_BLACK

CHK	ITEM	PART #	QTY	GRAPHIC
<input type="checkbox"/>	FRONT BODY PANEL TRIM	2H20345(STAINLESS) 2H20345 (EXT COLOR)	1	A
<input type="checkbox"/>	TOE KICK TRIM	TBD (EXT COLOR) TBD (STAINLESS)	1	B
<input type="checkbox"/>	SELF SERVICE BULKHEAD CAP	2H20347 (STAINLESS)	1	C
<input type="checkbox"/>	SERVICE BULKHEAD CAP	2H20348 (STAINLESS)	1	D
<input type="checkbox"/>	REAR ARM TRIM	2H20346 (STAINLESS)	1	E
<input type="checkbox"/>	REAR TOE KICK TRIM	2H22014 (STAINLESS)	1	F
<input type="checkbox"/>	UPPER FRONT BODY PANEL TRIM	2H20344 (EXT COLOR) 2H20344 (STAINLESS)	1	G
<input type="checkbox"/>	REAR UPPER RACEWAY TRIM	2H20350(STAINLESS)	1	H
<input type="checkbox"/>	REAR LOWER RACEWAY TRIM	2H20351(STAINLESS)	1	I
<input type="checkbox"/>	WASHER, 3/8"	300-03-1320	5	J
<input type="checkbox"/>	BOLT, 3/8 - 16 X 8	300-03-0902	2	K
<input type="checkbox"/>	GASKET SEAL TAPE	225-01-0628	16 FT	L
<input type="checkbox"/>	SEALANT, BUTYL, TUBE	100-01-0121	1	M
<input type="checkbox"/>	ALIGNMENT PIN	0376408	3	N
<input type="checkbox"/>	SPLINE H CHAN POLY 4 1/2	200-02-3022	1	O
<input type="checkbox"/>	JOINING NYLON WASHER	2H04205800	1	P
<input type="checkbox"/>	BOLT, 3/8 - 16 X 1.5	300-03-0850	3	Q
<input type="checkbox"/>	NUT, 3/8-16	300-03-1370	5	R
<input type="checkbox"/>	TRIM JOINT FRONT PLEX 6IN	2H21696 (EXT COLOR) 2H21696 (STAINLESS)	1	S
<input type="checkbox"/>	SEALANT, SILICONE, TUBE	100-01-0051 (CLEAR) 100-01-0063 (SILVER) 100-01-0065 (BLACK)	1	-
<input type="checkbox"/>	SCREW, SELF TAP #8 X 1/2	300-03-0037	12	-
<input type="checkbox"/>	VHB DOUBLE-SIDED TAPE	175-01-0562	16 FT	-
<input type="checkbox"/>	COUPLING, 2" PVC	225-01-0090	1	-

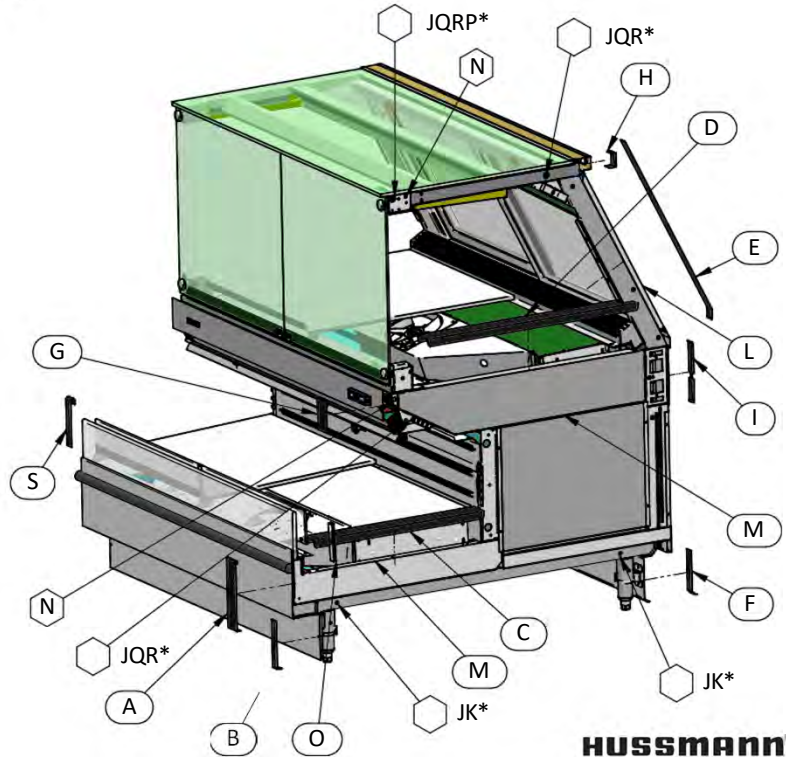

HUSSMANN
 REV E 01/21/2016

Installation (cont'd)

Arm Adjustment (HV Only)

STEP 1. Ensure case is level to the ground. Check level at the bulkhead as shown (LEVEL 1).

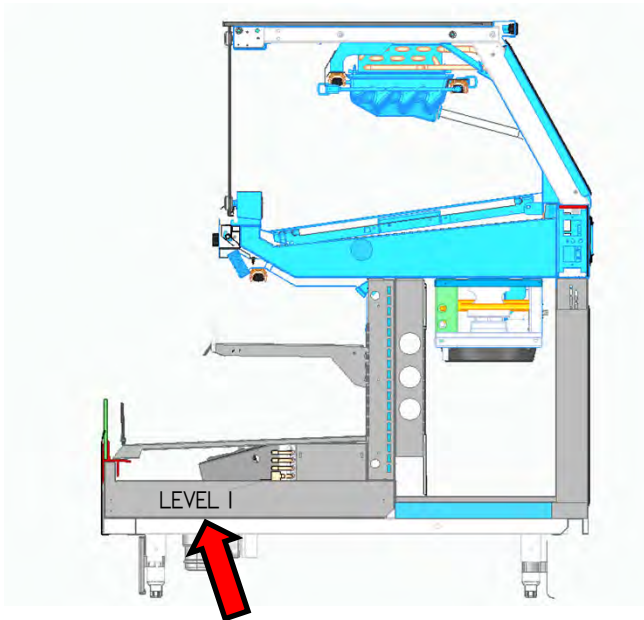

STEP 3. If the top arm is not level, remove the caps and cover and loosen the set screw on the front door hinges.

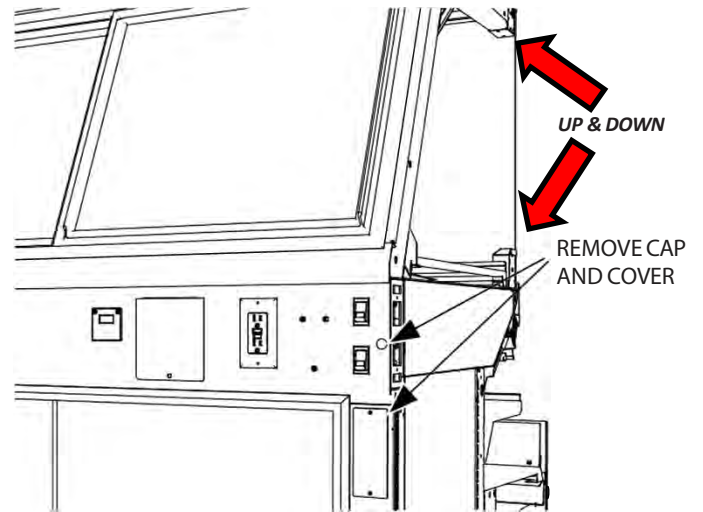

STEP 2. Place a level on top of the upper arm as shown (LEVEL 2).

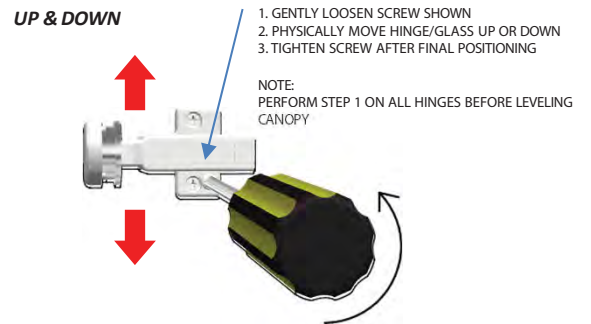
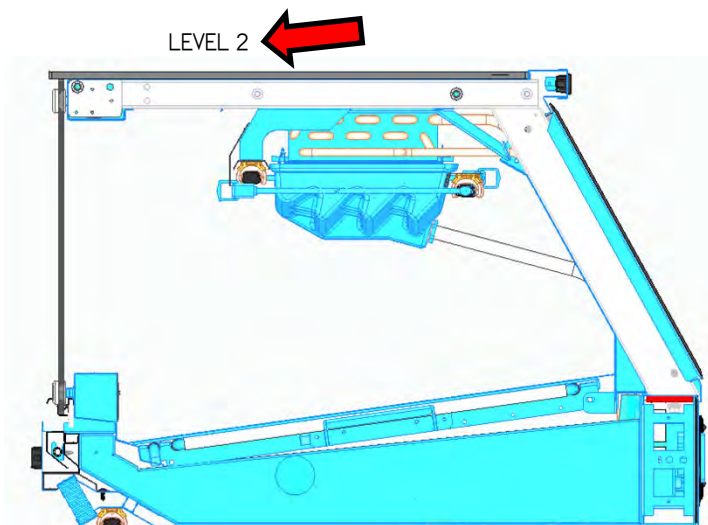

Installation (cont'd)

STEP 4. Loosen lock bolt (See Detail B)

STEP 5. Properly adjust the height of the glass requires that all hinge arms of each section be tightened or loosened evenly.

- Turning the bolt clockwise, the front arm and glass will lower.
- Turning the bolt counter-clockwise, the arm and glass will raise.

STEP 6. Tighten lock bolt

STEP 7. Replace access cap and cover.

IMPORTANT! Preload the canopy arm to minimize sag from product.

IMPORTANT! ATTEMPTING TO COMPENSATE FOR POOR INSTALLATION PRACTICES BY MANIPULATING THE CANOPY HARDWARE WILL RESULT IN UNSATISFACTORY WORKMANSHIP AND POSSIBLY CAUSE HARDWARE FAILURE AND/OR INJURY.

After all the glass height has been adjusted, tighten all the lock screws previously loosened.

Glass must be parallel to ledge when viewed from front. Glass height should be centered on "V" glass seal as demonstrated below

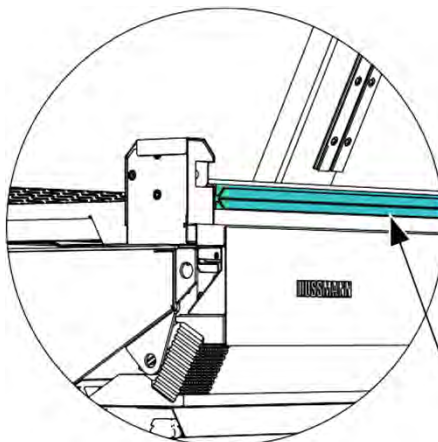

IMPORTANT: Attempting to compensate for poor installation practices by manipulating the canopy hardware will result in unsatisfactory workmanship and possibly cause hardware failure and/or injury.

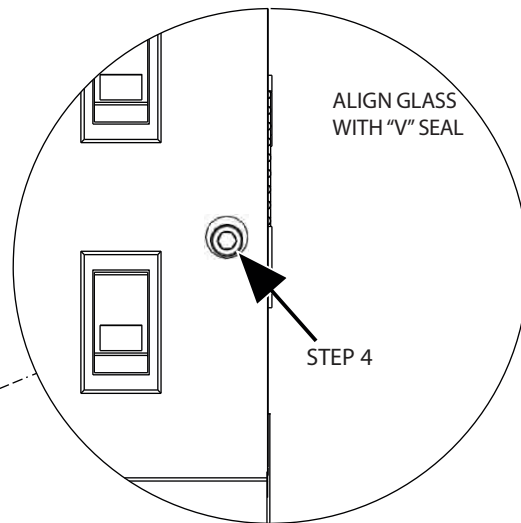
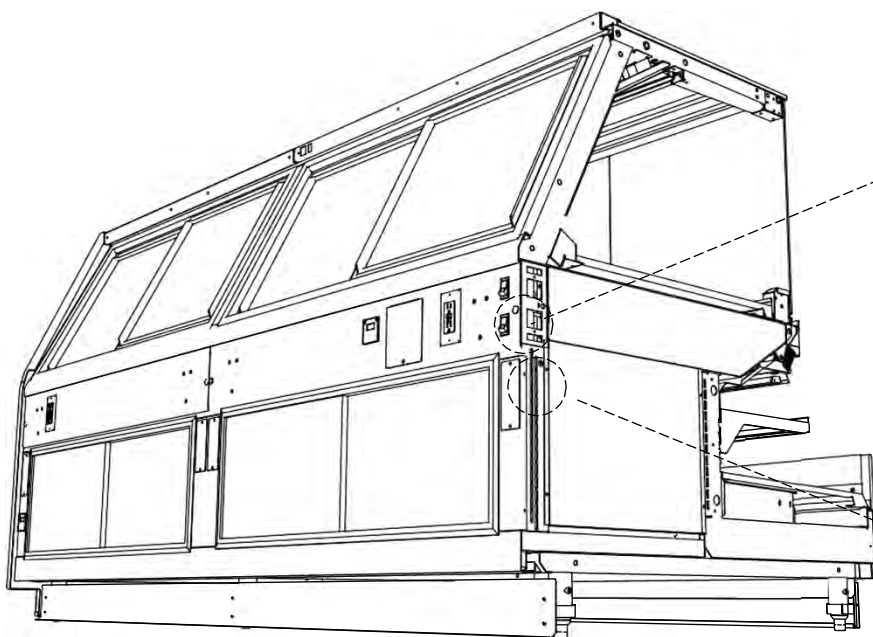

DETAIL A STEP 3

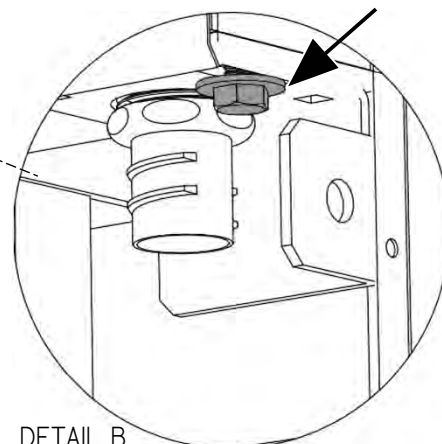

DETAIL B (BASE CHANNEL NOT SHOWN)

Installation (cont'd)

Arm Adjustment(NON-HV)

STEP 1. Ensure case is level to the ground. Check level as shown(pg 9).

STEP 2. Remove service section deck pans and arm drain/pipe covers to avoid damaging parts during adjustment.

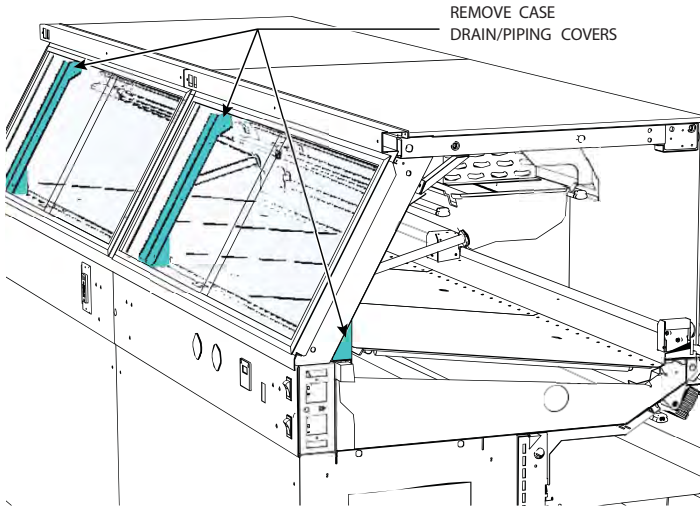

STEP 5. Locate and loosen lock bolts under each canopy arm.

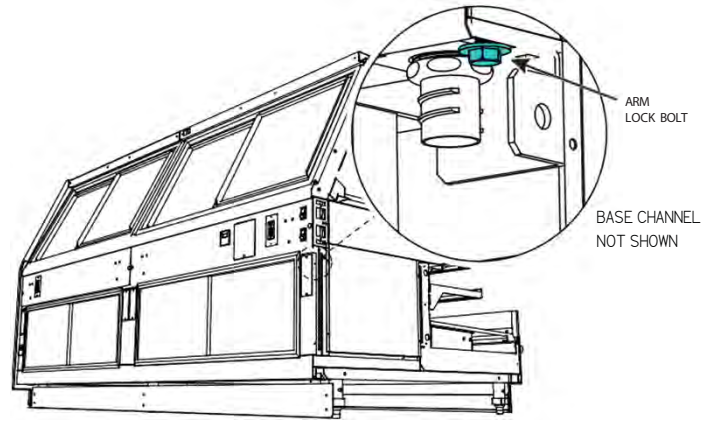

STEP 3. Remove fasteners from rear cover raceway to gain access to adjustment bolts.

*Note: Be careful to not damage/tug electrical outlets or devices attached to the raceway cover.

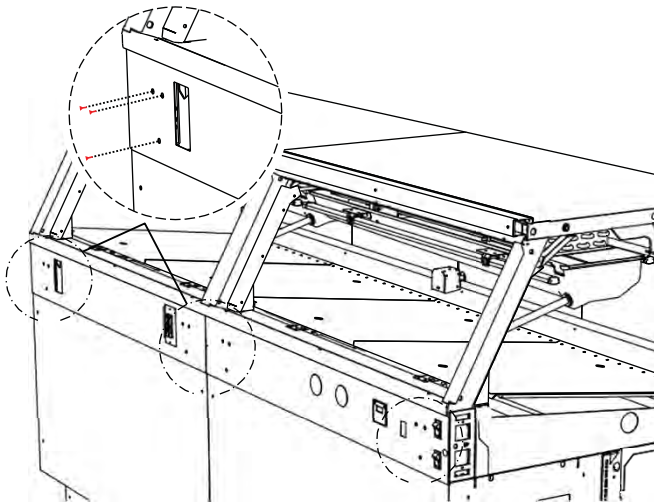

STEP 4. Place level on the top of the upper arms as shown to measure adjustments made to arms.

To properly adjust the height of the glass requires that all hinge arms of each section be loosened before attempting to change the arm position.

Installation (cont'd)

STEP 6. Shim each arm accordingly to bring canopy arms to level. Once proper height is achieved, tighten the lock-bolts and complete steps in reverse order to assemble case.

Once proper height is achieved, tighten the lock-bolts and complete steps in reverse order to assemble case. Glass must be parallel to ledge when viewed from front. Glass height should be centered on "V" glass seal as demonstrated below

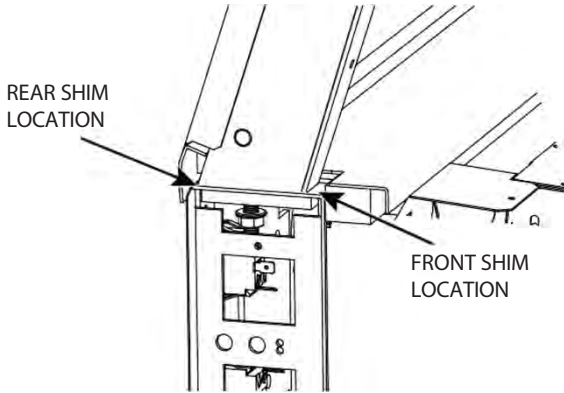

IMPORTANT: Attempting to compensate for poor installation practices by manipulating the canopy hardware will result in unsatisfactory workmanship and possibly cause hardware failure and/or injury.

**Note: Front and Rear Shimming*

- *Shimming from the front will raise the canopy arms*
- *Shimming from the rear will lower the canopy arms.*

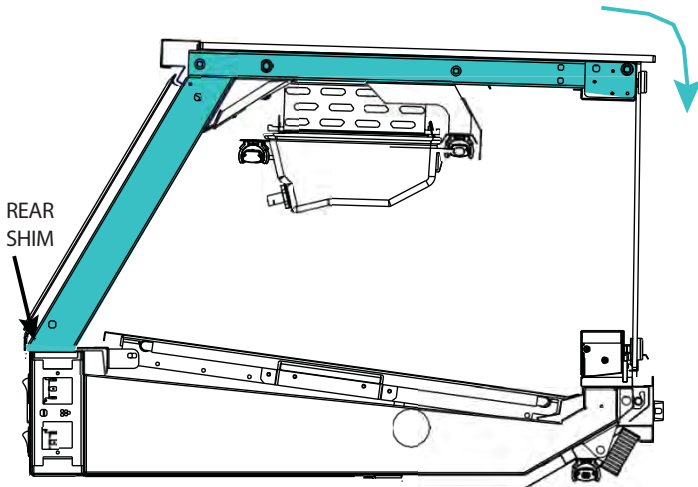
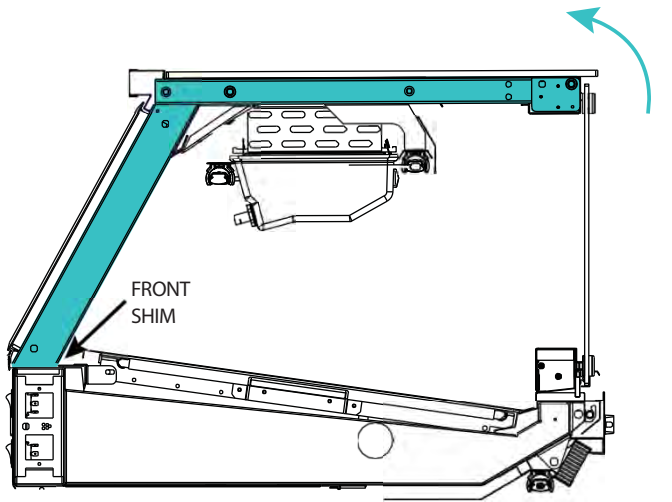
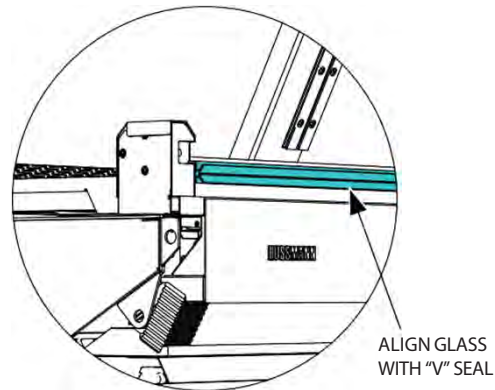

Installation (cont'd)

Glass Adjustment

Follow these steps accordingly to properly and safely adjust the positioning of the front glass.



Before adjusting glass
Set, Level, and Bolt together all cases
Double check leveling for all cases
Do not move lineup during adjustment

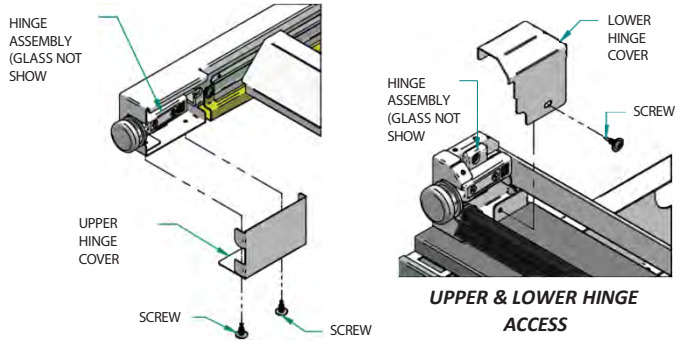

UP & DOWN

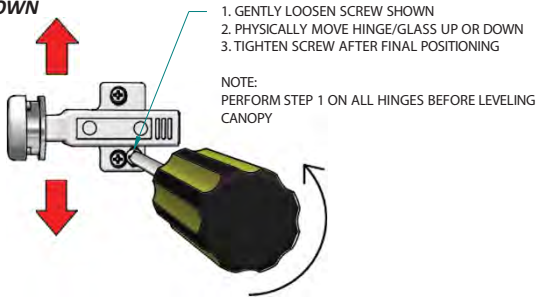

IN & OUT

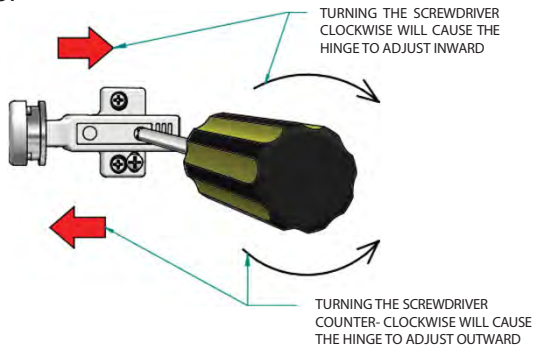

LEFT & RIGHT

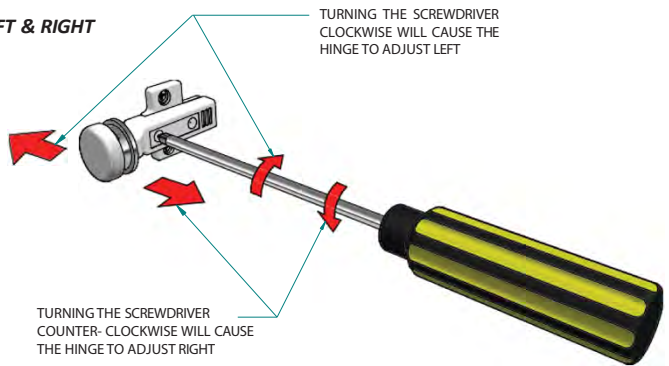

Glass must be parallel to front ledge when viewed from front. Glass height should be centered on "V" Glass Seal as demonstrated below.

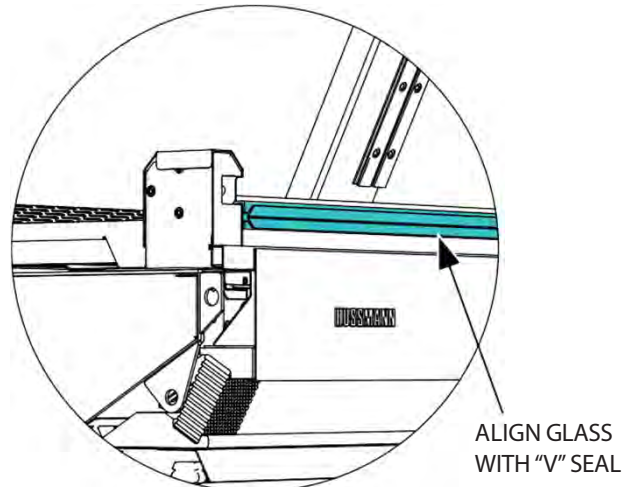

Installation (cont'd)

Setting and Joining

The sectional construction of these models enable them to be joined in line to give the effect of one continuous display.

Bolting locations which join like cases together are displayed below.

Leveling

IMPORTANT! IT IS IMPERATIVE THAT CASES BE LEVELED FROM FRONT TO BACK AND SIDE TO SIDE PRIOR TO JOINING. A LEVEL CASE IS NECESSARY TO INSURE PROPER OPERATION, WATER DRAINAGE, GLASS ALIGNMENT AND OPERATION OF THE HINGES SUPPORTING THE GLASS. LEVELING THE CASE CORRECTLY WILL SOLVE MOST HINGE OPERATION PROBLEMS.

1. Using case blueprints, measure off and mark on the floor the exact dimensions of where the cases will sit. Snap chalk line for front and back positions of base rail or pedestal. Mark the location of each joint front and back. Find the highest point throughout the lineup. **FLOORS ARE NORMALLY NOT LEVEL!** Determine the highest point of the floor; cases will be set off this point. All cases in the entire lineup must be brought up to the highest level of the case sitting at the highest point in the lineup.

2. Set first case over the highest part of the floor and adjust legs so that case is level.

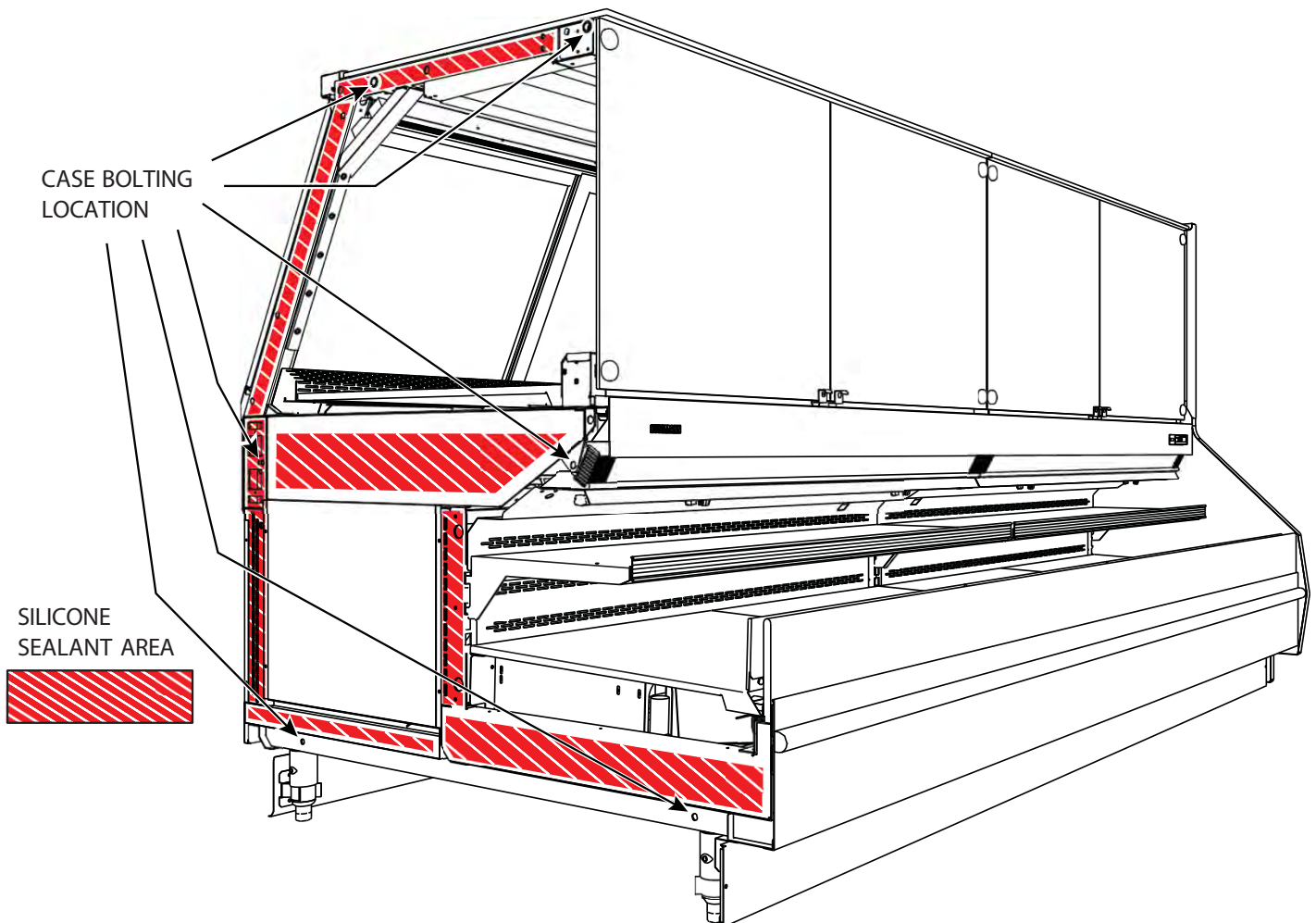

Installation (cont'd)

3. Set second case within one foot (1') of the first case. Keep the supports along the length of the case and far end of case. Level case to the first using the instructions in step one.

4. Apply liberal bead of case joint sealant (butyl) to first case. Sealant area is shown using a dotted line in illustration. Apply heavy amount to cover entire shaded area.

5. Apply liberal bead of case joint sealant (butyl) to first case. Sealant area is shown using a striped line in illustration in page 16. Apply heavy amount to cover entire shaded area.

6. Slide second case up to first case snugly. Then level second case to the first case so glass front, bumper and top are flush.



**ATTENTION
INSTALLER**

It is the contractor's responsibility to install case(s) according to local construction and health codes.



CAUTION

Do not use bolts to pull cases together.

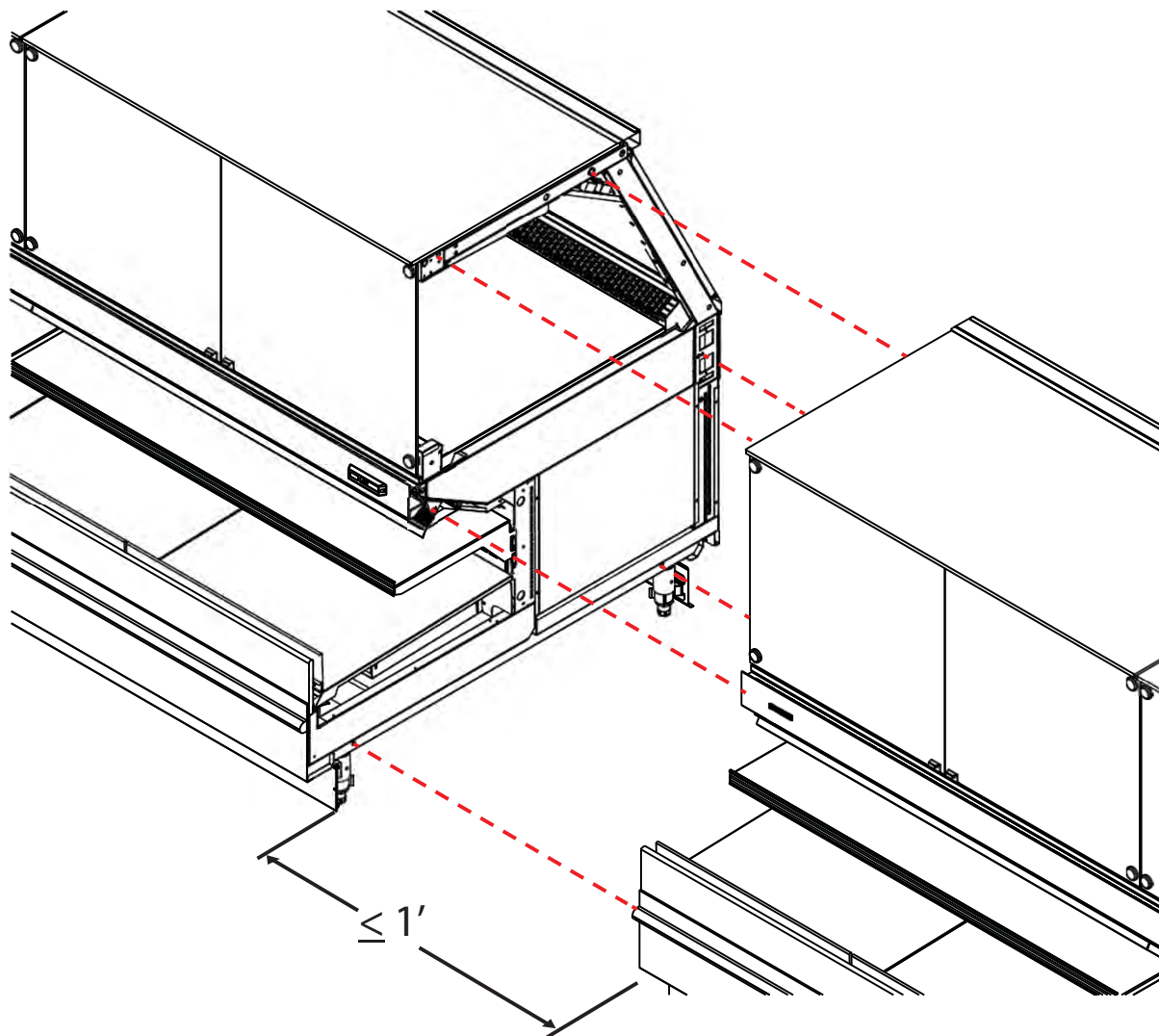

Installation (cont'd)

7. To compress butyl at joint, use two Jurgenson wood clamps. Make sure case is level from front to back and side to side on inside bulkheads at joint.

8. Attach sections together via the bolts pictured in the illustration below.

9. Apply bead of butyl to top of bulk heads and slip on stainless steel bulkhead cap under the refrigeration piping as pictured below . Also apply silicone to seam between joints.

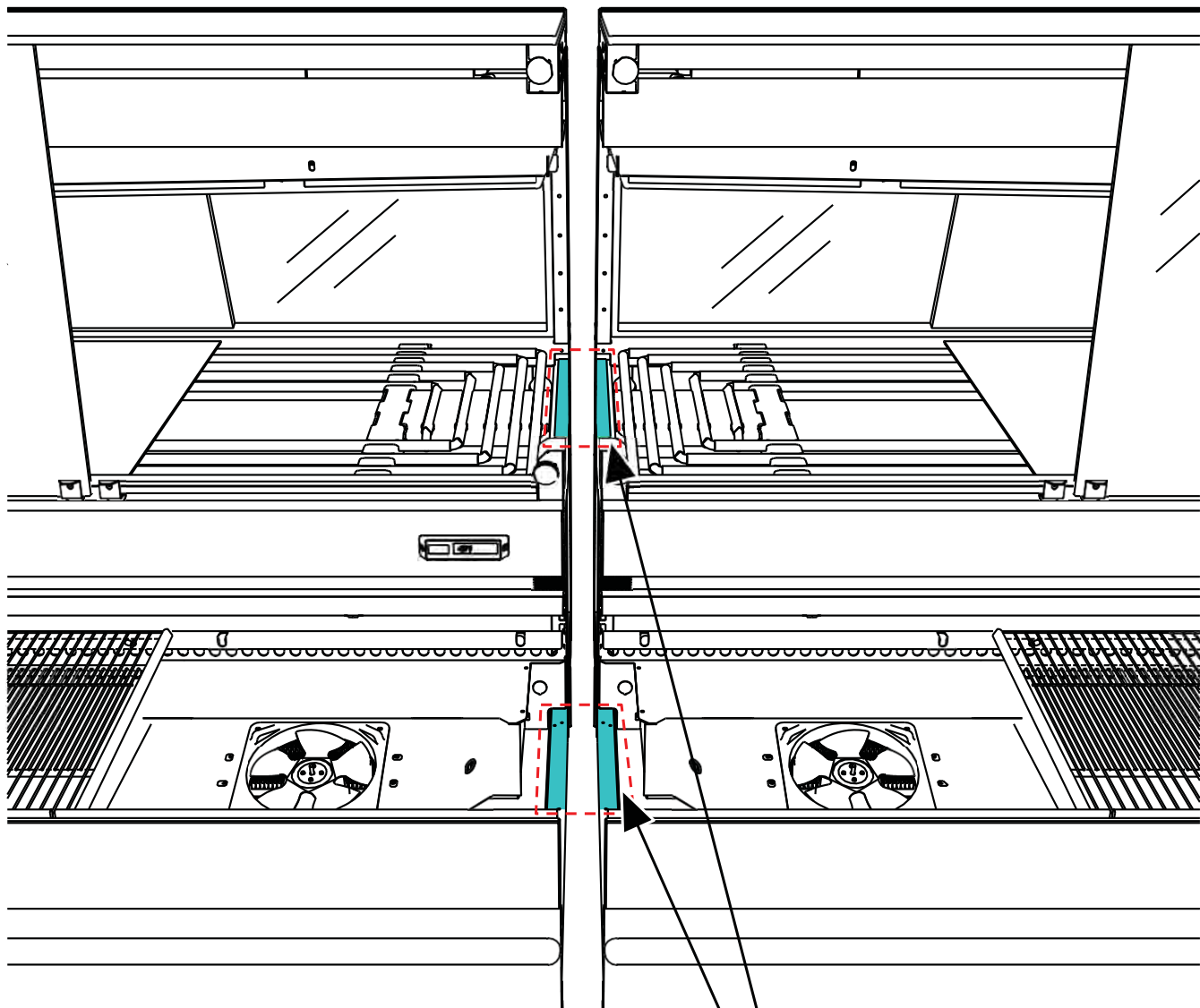

Refrigeration

Refrigerant

The correct type of refrigerant will be stamped on each merchandiser's serial plate. **The case refrigeration piping is pressurized with a nitrogen holding charge, leak tested and factory sealed.** Before making refrigeration hookups, depress universal line valve (Schrader Valve) to ensure that coils have maintained pressure during shipment. In the case pressure was not maintained contact your Hussmann Service Tech for further assistance.

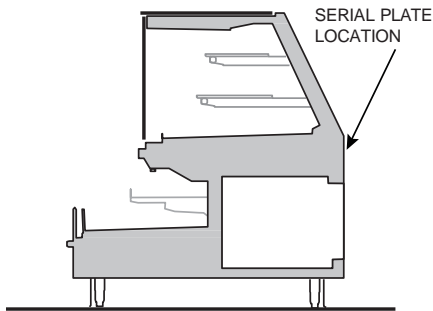

Refrigerant piping

The refrigerant line connections are at the right hand end of the case (as viewed from the front) beneath the display pans. The merchandiser will beforehand ensure an earlier cut hole through the pod to exit the merchandiser for the refrigeration lines. After connections have been made, make certain to seal this outlet thoroughly if not sealed at factory already. Seal both the inside and outside. We recommend using an expanding polyurethane foam insulation.

Line Sizing

Refrigerant should be sized as shown on the refrigeration legend that is furnished for the store or according to the ASHRAE guidelines

Oil Traps

Oil traps must be installed at the base of all suction line vertical risers on refrigerated cases.

P-Traps

P-TRAPS must be installed at the base of all refrigerated cases. The 1 1/2" P-TRAP and threaded adapter must be installed to prevent air leakage and insect entrance into the fixture.

CAUTION

Refrigeration lines are under pressure. Refrigerant must be recovered before attempting to make any connections.

**ATTENTION
INSTALLER**

It is the contractor's responsibility to install case(s) according to local construction and health codes.

WARNING!

Do NOT apply thread sealer to ABS P-Trap.



Refrigeration (cont'd)

Piping Diagram (General)

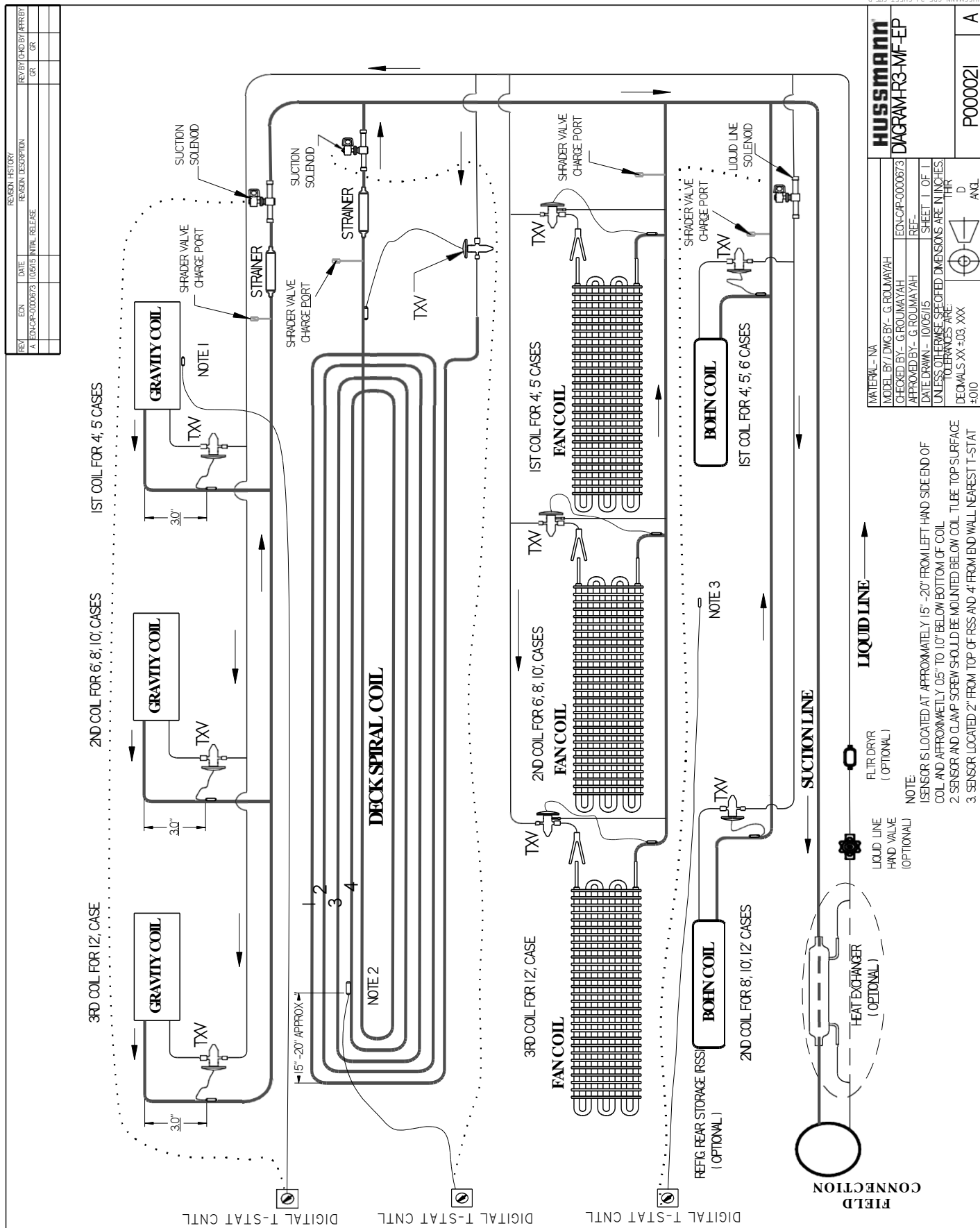

HUSSMANN		DIAGRAM R3-MF-EP	
MATERIAL - NA	MODEL BY / DWG BY - G. ROLIMAYAH	ECN-CAP-0000673	
CHECKED BY - G. ROLIMAYAH	DATE DRAWN - 10/05/15	REF.	SHEET 1 OF 1
APPROVED BY - G. ROLIMAYAH	UNLESS OTHERWISE SPECIFIED DIMENSIONS ARE IN INCHES	THR	D
	DECIMALS XX +03 XXX	ANG	E
	+010	ANGLES	+Z

PROJECTIO	N
P000021	A

FIELD CONNECTION

Refrigeration (cont'd)

Refrigeration Components

See demonstrations below for detailed overview of the VR3HV-M/F C/S-EP piping components.

Note: Refrigeration components have been fitted with a component tray for ease in use of cleaning and maintenance under the deck pans.

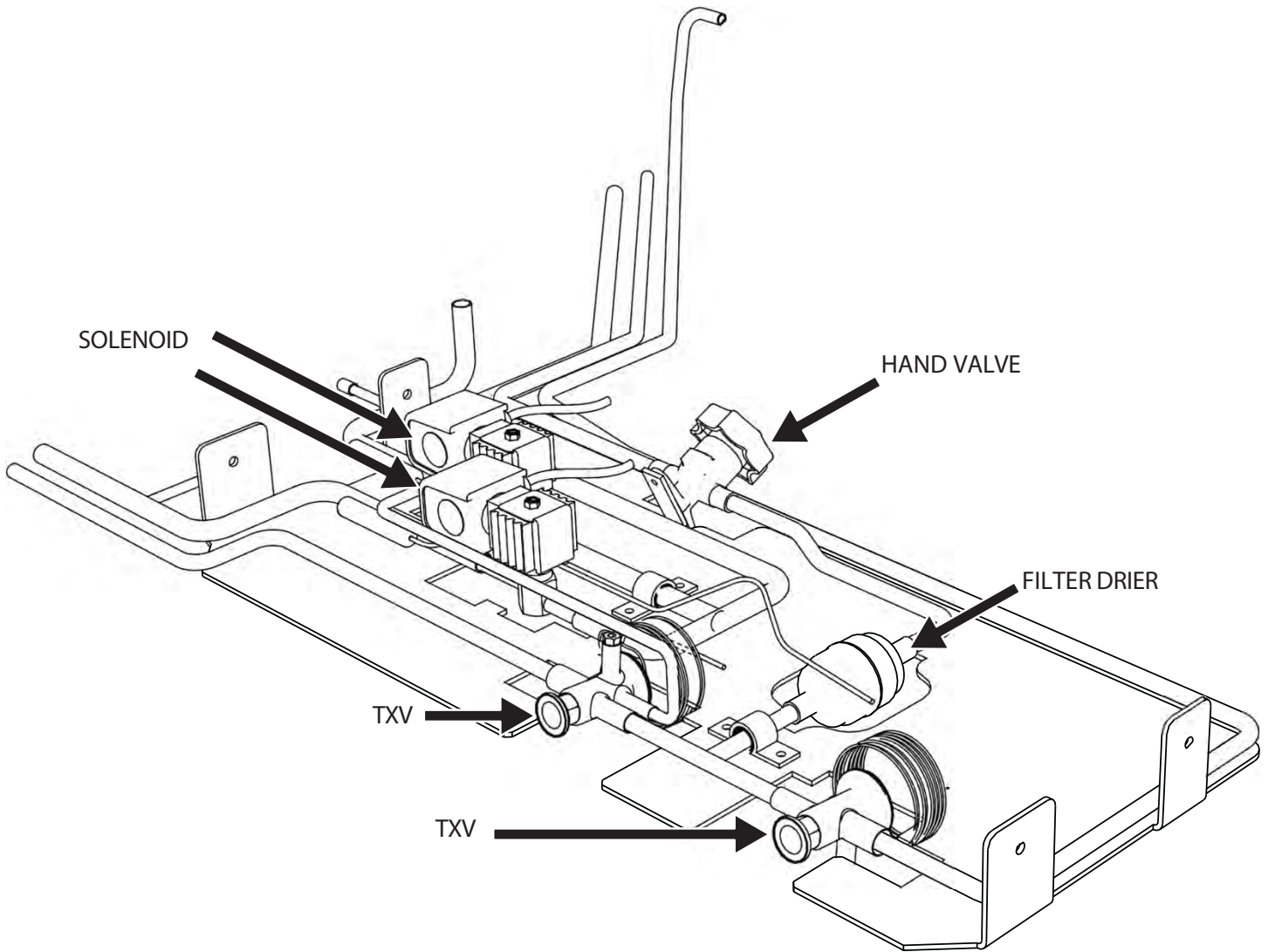

Refrigeration (cont'd)

Spiral Coil and Gravity Coil

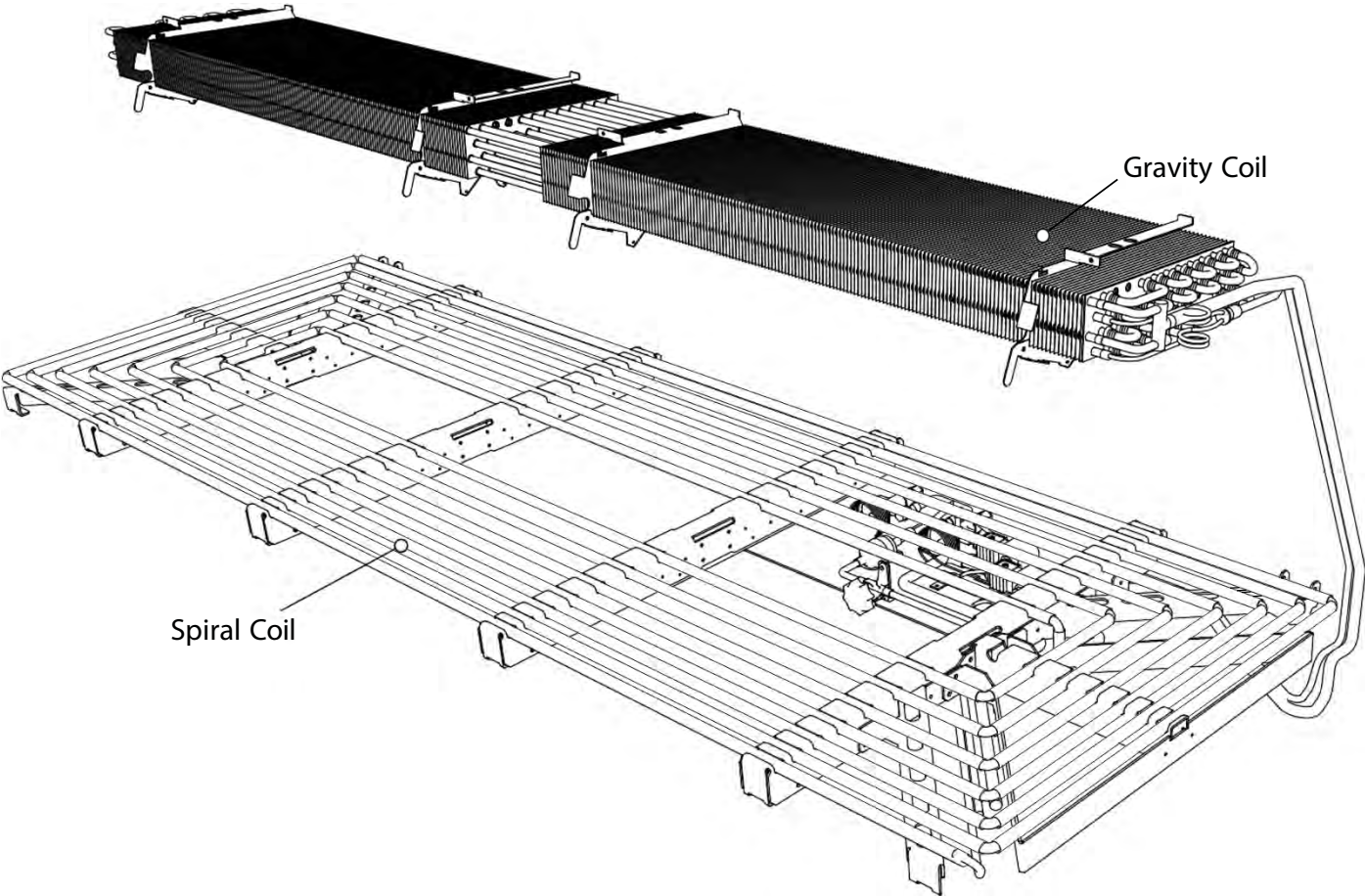

Refrigeration Spec Sheets



VERTICAL MEAT SERVICE - SELF SERVICE
HUSSMANN - VR3M/F-EP SH, +2H, & +4H OPTIONS (CHINO)

REVISION DATE 9/11/2020

DOE 2017 Energy Efficiency Compliant
 Hussmann refrigerated merchandisers configured for sale for use in the United States meet or surpass the requirements of the DOE 2017 energy efficiency standards.



VR3-M/F-EP Vertical Glass Meat
 Standard Service Dome, Multi Deck Self Service

VR3-M/F-EP +2 Vertical Glass Meat
 Standard Service Dome, Multi Deck Self Service +2' height

VR3-M/F-EP +4 Vertical Glass Meat
 Standard Service Dome, Multi Deck Self Service +4' height

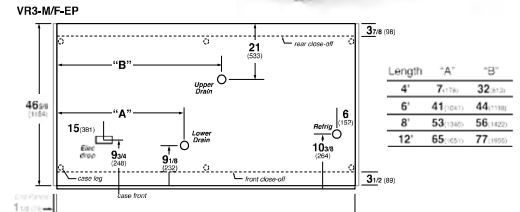
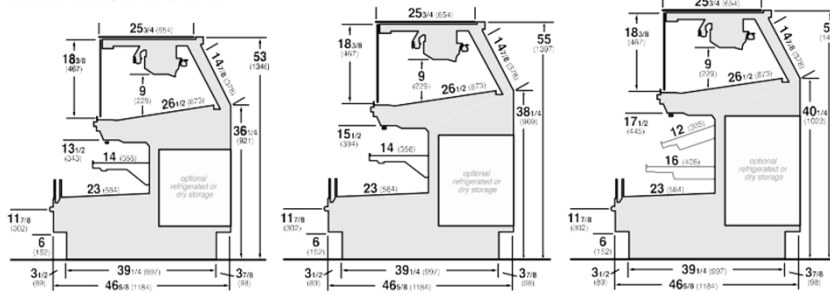

REFRIGERATION DATA:

CASE LENGTHS	CASE USAGE	CAPACITY TOP/FRONT *** (BTU/HR/FT)		TEMPERATURE (°F)			VELOCITY TOP/FRONT (FT/MIN)
		RATING CONDITION		EVAPORATOR TOP/FRONT		DISCHARGE AIR TOP/FRONT **	
		NSF 7	AHRI	NSF 7	AHRI 1200	NSF 7	
4', 6', 8', 10', 12'	MEAT/FISH	230/530	230/530	26/26	26/26	33-36/32-36	50-100/150-200
REAR STORAGE	MEAT/FISH	90	90	26	26	32-34	600-725

CASE LENGTH	EST. REFG. CHRG. 404A (LBS)	20°F GLYCOL 6° RISE					
		FRONT		TOP		REAR STORAGE	
		GPM	PSI	GPM	PSI	GPM	PSI
4'	1.8	0.7	1.7	0.4	0.3	0.2	0.0
6'	2.6	1.0	3.9	0.5	1.4	0.2	0.2
8'	3.5	1.4	1.8	0.7	0.4	0.3	0.5
10'	4.1	1.7	3.1	1.0	1.5	0.4	0.7
12'	5.2	2.0	3.7	1.0	1.4	0.4	0.9

**FRONT DISCHARGE AIR MEASURED INSIDE AIR CURTAIN HONEYCOMB

***REFRIGERATION NOTES:

- 1) BTU'S DO NOT INCLUDE LIGHTS
- 2) ADD 10 BTU'S PER FOOT/PER SHELF FOR OPTIONAL LED SHELF LIGHTS
- 3) 2H OPTION; ADD 45 BTU/HR/FT FOR THE FRONT, ADD 5 BTU/HR/FT FOR THE REAR STORAGE.
- 4) 4H OPTION; ADD 80 BTU/HR/FT FOR THE FRONT, ADD 10 BTU/HR/FT FOR THE REAR STORAGE.
- 6) AHRI 1200 RATING POINT FOR ENERGY CONSUMPTION COMPARISON ONLY
- 7) USE DEW POINT FOR HIGH GLIDE REFRIGERANTS. CARE SHOULD BE TAKEN TO USE THE DEW POINT IN P/T TABLES FOR MEASURING AND ADJUSTING SUPERHEAT. ADJUST EVAPORATOR PRESSURE AS NEEDED TO MAINTAIN THE DISCHARGE AIR TEMPERATURE SHOWN.
- 8) RATING CONDITION IS NSF TYPE I, 75°F/55% RH

REFRIGERATION DATA CONTINUED:

USAGE	ELEC. THERMOSTAT / AIR SENSOR SETTINGS		DEFROST TYPE	TIME (MIN)	DEFROST FREQUENCY (#/DAY)	TERM. TEMP (°F) COIL ONLY	DRIP TIME	DEFROST WATER (LBS/DAY/FT)
	CUT IN (°F)	CUT OUT (°F)						
TOP GRAVITY	34	33	OFF TIME	30	4	45	N/A	0.6
TOP DECK	29	28						
FRONT	28	26						
REAR STORAGE	37	36						

END PANEL WIDTH KEY		
# OF END PNLS	END PNL WIDTH (IN.)	TOTAL ADDED LENGTH (IN.)
1	1.125	1.125
1	1.125	1.125
2	1.125	2.25

ELECTRICAL DATA:

STANDARD FANS, HEATERS, LED LIGHTS (115 VOLT)

CASE LENGTH	TOTAL EVAPORATOR FANS				CANOPY LIGHTS LED TOP AND FRONT		OPTIONAL LED SHELF LIGHTS TOP AND FRONT		MAX. LED LOAD (W/ ALL OPTIONS)		ANTI-SWEAT HEATERS (ON FAN CIRCUIT)		CONVENIENCE OUTLETS (OPTIONAL)			
	# OF EVAP FANS	BLADE DIA. (IN.)	BLADE PITCH FRONT (°)	AMPS	WATTS	AMPS	WATTS	AMPS	WATTS	AMPS	WATTS	AMPS	WATTS	# OUTLETS	VOLTS	AMPS
4'	2	6.7	15	0.2	16	0.2	28	0.1	10	0.3	39	0.9	100	1	115	15
6'	4	6.7	15	0.5	32	0.4	44	0.1	15	0.5	59	1.3	150	1	115	15
8'	4	6.7	15	0.5	32	0.5	57	0.2	21	0.7	77	1.7	200	1	115	15
10'	4	6.7	15	0.5	32	0.5	62	0.2	26	0.8	88	2.2	250	1	115	15
12'	6	6.7	15	0.7	48	0.7	85	0.3	31	1.0	116	2.6	300	2	115	30

OPTIONAL HIGH OUTPUT LED LIGHTS (115 VOLT)

CASE LENGTH	CANOPY LIGHTS H.O. LED		OPTIONAL SHELF		MAX. H.O. LED LOAD	
	AMPS	WATTS	AMPS	WATTS	AMPS	WATTS
4'	0.4	43	0.2	26	0.6	69
6'	0.5	54	0.4	41	0.8	96
8'	0.8	87	0.4	51	1.2	138
10'	N/A	N/A	N/A	N/A	N/A	N/A
12'	1.1	130	0.7	77	1.8	207

REFRIGERATED REAR STORAGE (OPTIONAL) EVAP. FANS

# OF EVAP FANS	BLADE DIA. (IN.)	BLADE PITCH (°)	AMPS	WATTS
1	6.70	30	0.3	8.8
1	6.70	30	0.3	8.8
1	6.70	30	0.3	8.8
1	6.70	30	0.3	8.8
1	6.70	30	0.3	8.8

Refrigeration Spec Sheets(Cont'd)



HIGH VOLUME MEAT/FISH SERVICE - SELF SERVICE

REVISION DATE 9/11/2020

HUSSMANN - VR3HV-M/F-EP SH, +2H, & +4H OPTIONS (CHINO)

DOE 2017 Energy Efficiency Compliant
 Hussmann refrigerated merchandisers configured for sale for use in the United States meet or surpass the requirements of the DOE 2017 energy efficiency standards.

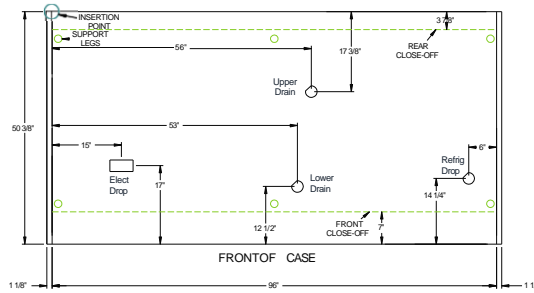
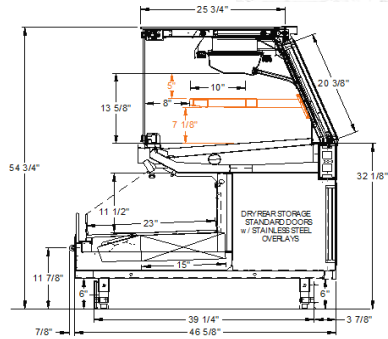

REFRIGERATION DATA:

CASE LENGTHS	CASE USAGE	CAPACITY TOP/FRONT*** (BTU/HR/FT)		TEMPERATURE (°F)			VELOCITY TOP/FRONT (FT/MIN)
		RATING CONDITION		EVAPORATOR TOP/FRONT		DISCHARGE AIR TOP/FRONT **	
		NSF 7	AHRI 1200	NSF 7	AHRI 1200	NSF 7	
4', 6', 8', 10', 12'	MEAT/FISH	230/450	230/450	26/26	26/26	33-36/33-36	50-100/150-200
REAR STORAGE	MEAT/FISH	90	90	26	26	33-35	380-600
4', 6', 8', 10', 12'	M/F w/SHELF	250/450	250/450	20/26*	20/26*	24-29/30-32	50-100/150-200
REAR STORAGE	M/F w/SHELF	90	90	26*	26*	33-35	380-600

CASE LENGTH	EST. REFG. CHR.G. 404A (LBS)	20°F GLYCOL 6° RISE					
		FRONT		TOP		REAR STORAGE	
		GPM	PSI	GPM	PSI	GPM	PSI
4'	1.8	0.7	1.5	0.4	0.3	0.1	0.0
6'	2.6	1.0	3.7	0.5	1.4	0.2	0.1
8'	3.5	1.3	1.7	0.7	0.4	0.2	0.3
10'	4.1	1.6	2.9	1.0	1.5	0.3	0.5
12'	5.2	1.9	3.5	1.0	1.4	0.4	0.7

*EPR REQUIRED FOR FRONT SECTION WHEN SHELF IS USED

**FRONT DISCHARGE AIR MEASURED INSIDE AIR CURTAIN HONEYCOMB

***REFRIGERATION NOTES:

- 1) BTU'S DO NOT INCLUDE LIGHTS
- 2) ADD 10 BTU'S PER FOOT/PER SHELF FOR OPTIONAL LED SHELF LIGHTS
- 3) 2H OPTION; ADD 45 BTU/HR/FT FOR THE FRONT, ADD 5 BTU/HR/FT FOR THE REAR STORAGE.
- 4) 4H OPTION; ADD 80 BTU/HR/FT FOR THE FRONT, ADD 10 BTU/HR/FT FOR THE REAR STORAGE.
- 5) AHRI 1200 RATING POINT FOR ENERGY CONSUMPTION COMPARISON ONLY
- 6) USE DEW POINT FOR HIGH GLIDE REFRIGERANTS. CARE SHOULD BE TAKEN TO USE THE DEW POINT IN P/T TABLES FOR MEASURING AND ADJUSTING SUPERHEAT. ADJUST EVAPORATOR PRESSURE AS NEEDED TO MAINTAIN THE DISCHARGE AIR TEMPERATURE SHOWN.
- 7) RATING CONDITION IS NSF TYPE I, 75°F/55% RH
- 8) SHELF CASE GRAV COIL SUPERHEAT TYPICALLY 2°F, ALSO INCREASE DEFROST SCHEDULE ~1-2 MINUTES PER 1°F AMBIENT BELOW 75°F

REFRIGERATION DATA CONTINUED:

ELEC. THERMOSTAT / AIR SENSOR SETTINGS			DEFROST TYPE	TIME (MIN)	DEFROST FREQUENCY (#/DAY)	TERM. TEMP (°F) COIL ONLY	DRIP TIME	DEFROST WATER (LBS/DAY/FT)
USAGE	CUT IN (°F)	CUT OUT (°F)						
TOP GRAV	33	32	OFF TIME	30	4	45	N/A	0.6
TOP DECK	28	27				N/A	N/A	
FRONT	28	26				48	N/A	2.4
REAR STORAGE	37	36				45	N/A	0.2
WITH SHELF = S			OFF TIME	45	4	43	N/A	1.0
S/ TOP GRAV	27	25				N/A	N/A	
S/ TOP DECK	33	32				48	N/A	2.6
S/ FRONT	28	26				45	N/A	0.2
S/ REAR STOR	37	36				45	N/A	

END PANEL WIDTH KEY		
# OF END PNLS	END PNL WIDTH (IN.)	TOTAL ADDED LENGTH (IN.)
1	1.125	1.125
2	1.125	2.25

ELECTRICAL DATA:

STANDARD FANS, HEATERS, LED LIGHTS (115 VOLT)

CASE LENGTH	EVAPORATOR FANS: TOP AND FRONT				CANOPY LIGHTS LED TOP AND FRONT		OPTIONAL LED SHELF LIGHTS TOP AND FRONT		MAX. LED LOAD (W/ ALL OPTIONS)		ANTI-SWEAT HEATERS		CONVENIENCE OUTLETS (OPTIONAL)			
	# OF EVAP FANS	BLADE DIA. (IN.)	BLADE PITCH FRONT (°)	AMPS	WATTS	AMPS	WATTS	AMPS	WATTS	AMPS	WATTS	AMPS	WATTS	# OUTLETS	VOLTS	AMPS
4'	3	6.70	15	0.4	24	0.3	31	0.1	10	0.4	41	0.9	100	1	115	15
6'	6	6.70	15	0.7	48	0.4	46	0.1	15	0.5	61	1.3	150	1	115	15
8'	6	6.70	15	0.7	48	0.5	62	0.2	21	0.7	82	1.7	200	1	115	15
10'	6	6.70	15	0.7	48	0.6	73	0.2	26	0.9	99	2.2	250	1	115	15
12'	9	6.70	15	1.1	72	0.8	93	0.3	31	1.1	124	2.6	300	2	115	30

OPTIONAL HIGH OUTPUT LED LIGHTS (115 VOLT)

CASE LENGTH	CANOPY LIGHTS H.O. LED TOP AND FRONT		OPTIONAL SHELF TOP AND FRONT		MAX. H.O. LED LOAD	
	AMPS	WATTS	AMPS	WATTS	AMPS	WATTS
4'	0.3	33	0.2	26	0.5	59
6'	N/A	N/A	N/A	N/A	N/A	N/A
8'	0.6	66	0.4	51	1.0	117
10'	N/A	N/A	N/A	N/A	N/A	N/A
12'	0.9	100	0.7	77	1.5	176

CASE LENGTH	EVAPORATOR FANS: REFRIGERATED REAR STORAGE (OPTIONAL)				
	# OF EVAP FANS	BLADE DIA. (IN.)	BLADE PITCH (°)	AMPS	WATTS
4'	1	6.70	30	0.3	8.8
6'	1	6.70	30	0.3	8.8
8'	1	6.70	30	0.3	8.8
10'	1	6.70	30	0.3	8.8
12'	1	6.70	30	0.3	8.8

Electrical

Merchandise Electrical Data

Technical data sheets are shipped with this manual. The data sheets provide merchandise electrical data. Refer to the technical data sheets and merchandise serial plate for electrical information.

Electrical Connections

All wiring must be in compliance with NEC and local codes. All electrical connections including both supply circuits are to be made in the electrical J-Box.

Field Wiring

Field wiring must be sized for component amperes stamped on the serial plate (refer to pg 18 for location). Actual ampere draw may be less than specified.

Identification of Wiring

Leads for all electrical circuits are identified by colored plastic bands. These bands correspond to the color code sticker (shown below) located inside the merchandise's wireway cover.

ALWAYS CHECK THE SERIAL PLATE FOR COMPONENT AMPERES

WARNING

--LOCK OUT/TAG OUT--

To avoid serious injury or death from electrical shock, always disconnect the electrical power at the main disconnect when servicing or replacing any electrical component. This includes, but is not limited to, such items as doors, lights, fans, heaters, and thermostats.

STANDARD CASE WIRE COLOR CODE CODIGO DE COLORES DE LOS ALAMBRES PARA LAS VITRINAS ESTANDAR CODE COULEUR POUR FILS DE BOITIER NORMALISE		
COLOR DESCRIPTION	DESCRIPCION	DESCRIPTION
■ GROUND	TIERRA MASA	MASSE
■ ANTI-SWEAT	ANTICONDENSACION	ANTI-SUINTEMENT
■ LIGHTS	LUCES	ECLAIRAGE
■ RECEPTACLES	ENCHUFES	PRISE DE COURANT
■ T-STAT/SOLENOID 230VAC	TERMOSTATO/SOLENOIDE (230VAC)	SOUPAPE A SOLENOID (230 VAC)
■ T-STAT/SOLENOID 115VAC	TERMOSTATO/SOLENOIDE (115VAC)	SOUPAPE A SOLENOID (115 VAC)
■ T-STAT/SOLENOID 24VAC	TERMOSTATO/SOLENOIDE (24VAC)	SOUPAPE A SOLENOID (24 VAC)
■ FAN MOTORS	VENTILADORES	VENTILATEUR
BLUE CONDENSING UNIT	UNIDAD DE CONDENSACION	UNITE DE CONDENSATION

USE COPPER CONDUCTORS ONLY

UTILISEZ LES CONDUCTEURS DE CUIVRE SEULEMENT

UTILICE LOS CONDUCTORES DE COBRE SOLAMENTE

430-01-0338 R101003

Electrical Cont'd

Remove Rear Raceway

The Merchandisers Electrical access is located at the rear of the case. Fasteners must be removed in order to gain access. See illustration below in order to remove rear raceway from case.

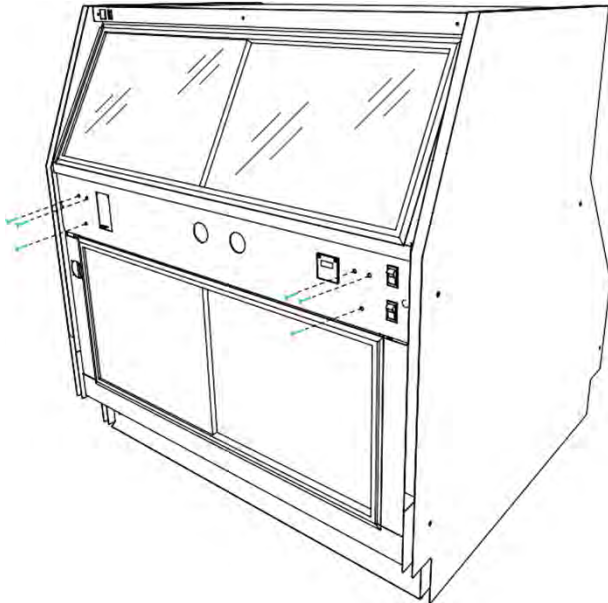

Electrical Conduit (Electrical Box)

The Merchandisers Electrical conduit can be found inside the compartment at the rear. Removing the raceway will gain access to the electrical components inside the J-Box allowing any maintenance necessary.

Electrical Conduit containing all necessary electrical components including but not limited to Digital T-Stats are located behind the rear raceway covers of the merchandiser.

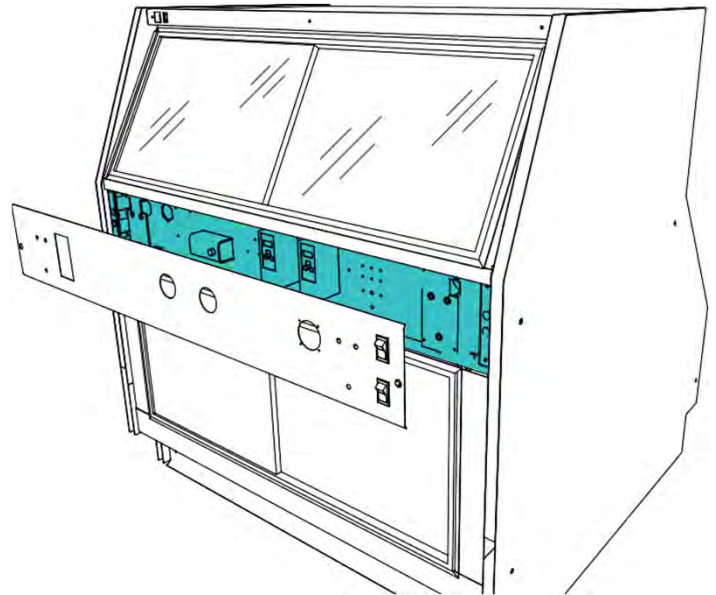

Wiring Diagram Index

VR3HV-M/FV-EP-R	VR3HV-M/FV-EP-4R	4'	3014834
	VR3HV-M/FV-EP-6R	6'	3014835
	VR3HV-M/FV-EP-8R	8'	3014836
	VR3HV-M/FV-EP-10R	10'	3028818
	VR3HV-M/FV-EP-12R	12'	3014837
VR3-M/FV-EP-R	VR3-M/FV-EP-4R	4'	3014732
	VR3-M/FV-EP-6R	6'	3014731
	VR3-M/FV-EP-8R	8'	3014730
	VR3-M/FV-EP-12R	12'	3014729

REV	EN	DATE	REVISION DESCRIPTION	REV BY	CHK BY	APPR BY
A	ECN-CAP-0003964	2016/08/08	RELEASED TO PRODUCTION	CB	CB	CB
B	ECN-CAP-0005979	2017/01/12	REVISED REAR STORAGE COIL	CB	CB	CB
C	ECN-CAP-0006209	2017/01/12	REVISED REAR STORAGE T-STAT	CB	CB	CB
D	ECN-COD-001845	2020/01/12	RE-LABELLED DIGITAL T-STATS	CB	CB	CB
E	ECN-COD-0015274	2022/01/09	NEW LIGHTS	CB	CB	CB
F	ECN-COD-0018714	2023/10/26	CHANGED FAN S LIGHTS	CB	CB	CB

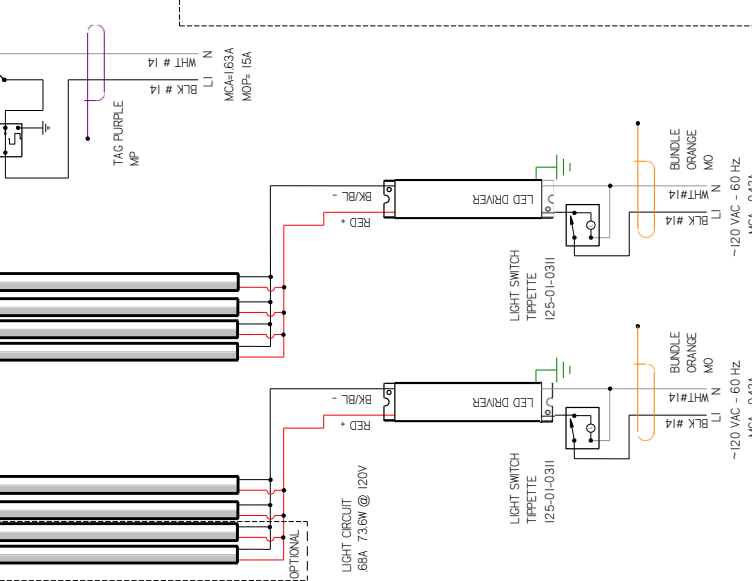
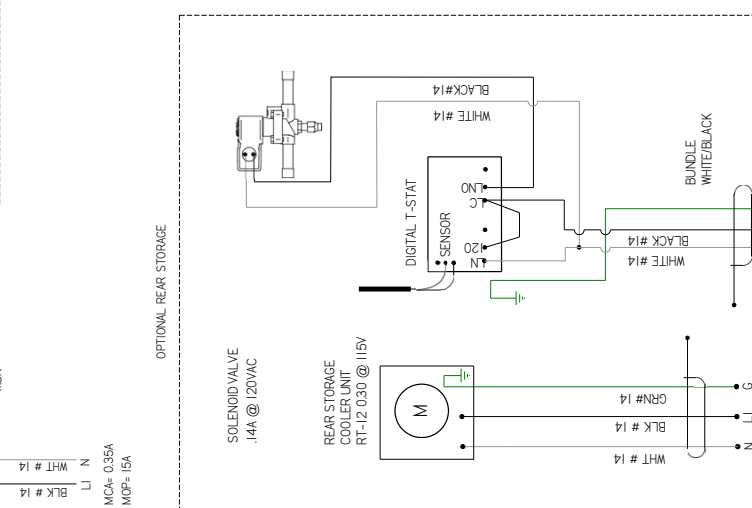
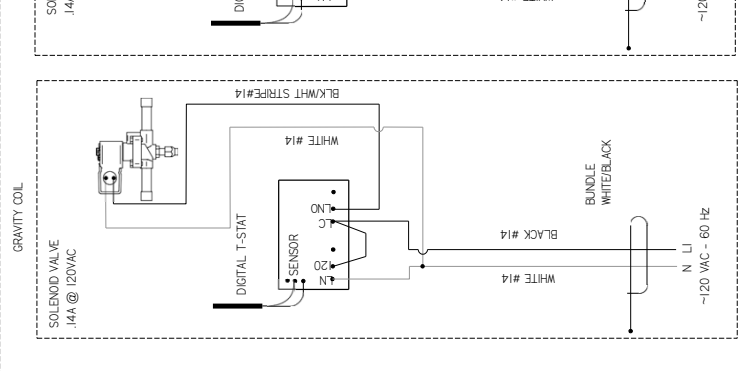
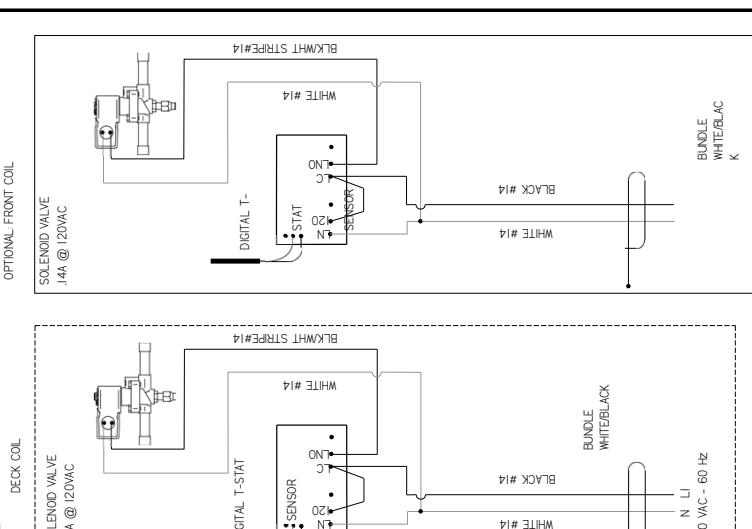
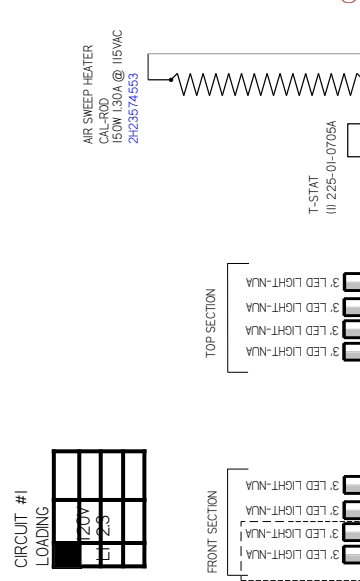
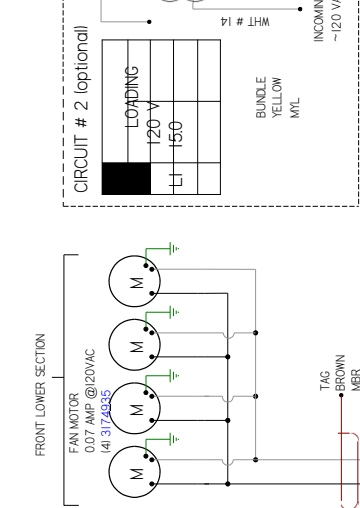
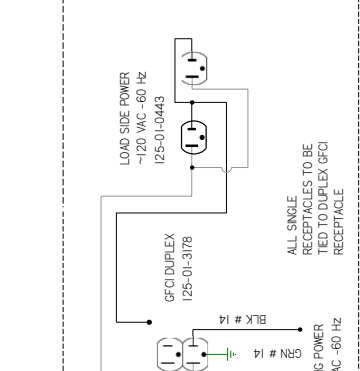

HUSSMANN

DATE DRAWN - 9-9-16
DRAWN BY - CRAIG BOOREY
REVIEWED BY - CRAIG BOOREY
UNLESS OTHERWISE SPECIFIED DIMENSIONS ARE IN INCHES
TOLERANCES ARE:
DECIMALS .XX +03 .XXX
ANGLES ± 2°

DIAGRAM=VR3HV-MIT
120VAC - 60 Hz
REF -
-EP-6R

3014835 | F

PROJECTION

CIRCUIT #1 LOADING

120V	
2-3	

CIRCUIT #2 optional

LOADING	
120V	
150V	

BUNDLE YELLOW MYL

NOTE:
CASE MUST BE GROUNDED
WHEN PASSING WIRES THROUGH METAL HOLES A GROMMET MUST BE USED

REV	EN	DATE	REVISION DESCRIPTION	REV BY	CHK BY	APPR BY
A	ECN-CAP-0003964	2016/09/08	RELEASED TO PRODUCTION	CB	CB	CB
B	ECN-CAP-0005978	2017/01/12	REVISED REAR STORAGE COIL	CB	CB	CB
C	ECN-CAP-0006209	2017/02/24	REVISED REAR STORAGE T-STAT	CB	CB	CB
D	ECN-CAP-0006209	2017/02/24	MATCH REVISION IN TEAM CENTER	CB	CB	CB
E	ECN-CAP-0014936	2018/01/03	ADDED T-STAT PART NUMBER	CB	CB	CB
F	ECN-CAP-0014936	2018/01/12	RE-LABELLED DIGITAL T-STATS	CB	CB	CB
G	ECN-COD-0015274	2018/01/12	NEW LIGHTS	CB	CB	CB
H	ECN-COD-0018174	2018/01/12	CHANGED FANS & LIGHTS	CB	CB	CB

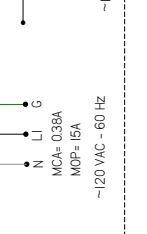
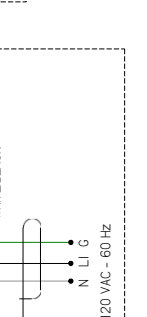
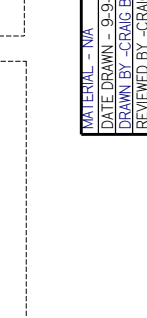
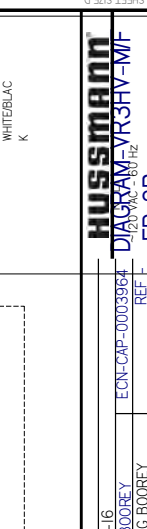
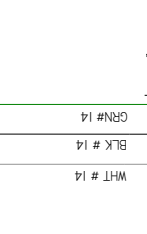
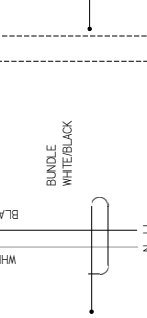
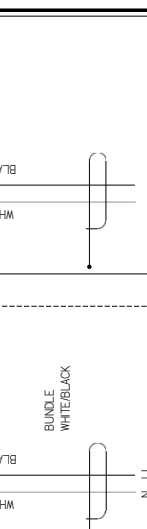
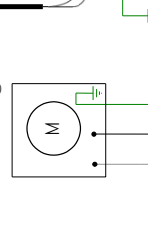
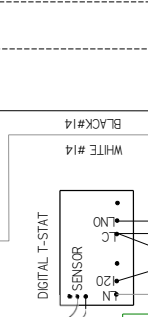
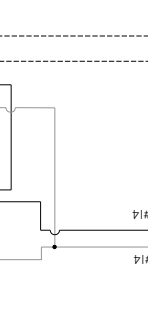
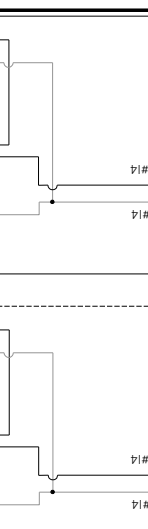
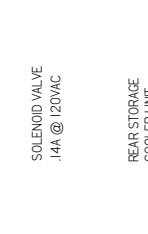
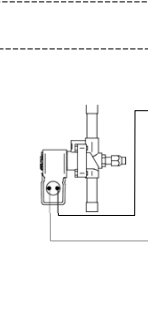
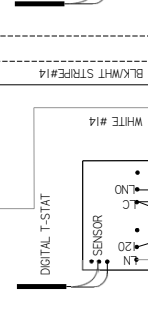
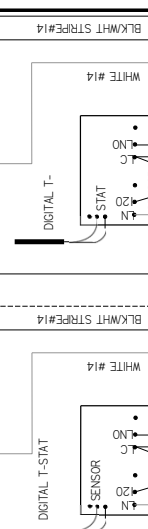
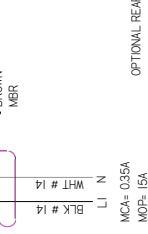
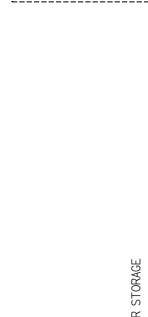
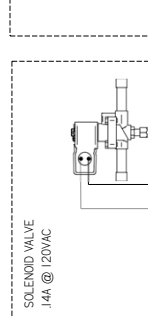
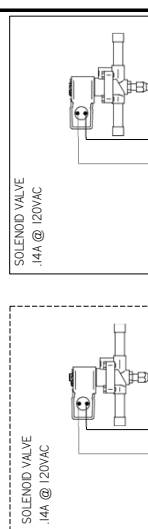
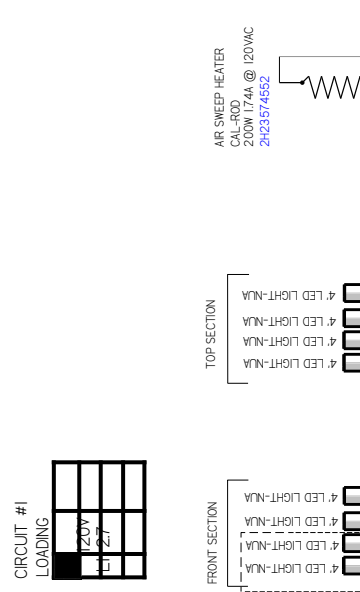
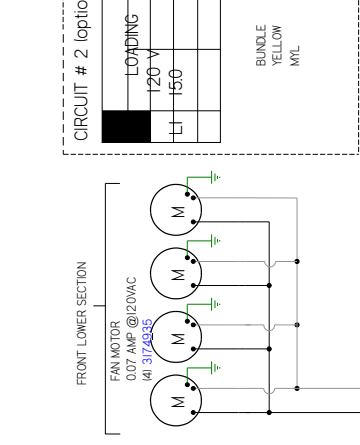
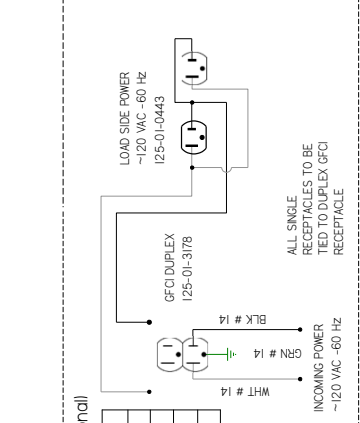

HUSSMANN
DIAGRAM YR3HV-MF
 120VAC-60Hz
-EP-8R

MATERIAL - N/A
 DATE DRAWN - 9-9-16
 DRAWN BY - CRAIG BOOREY
 REVIEWED BY - CRAIG BOOREY
 APPROVED BY - CRAIG BOOREY
 SHEET NO. 1 OF 1
 UNLESS OTHERWISE SPECIFIED DIMENSIONS ARE IN INCHES
 TO LEAST SIGNIFICANT DIGIT
 DECIMALS .XX +03 .XXX
 ±0.0
 ANGLE PROJECTION
 E

3014836 | H

NOTES:
 CASE MUST BE GROUNDED
 WHEN PASSING WIRES THROUGH METAL HOLES A GROMMET MUST BE USED

REVISION HISTORY		REV	BY	DATE	DESCRIPTION	CHKD BY	APPR BY
A	ECN-CAP-000848	1	CE	20170816	RELEASED TO PRODUCTION	CE	CE
B	ECN-CO-001845	2	CE	2020/01/02	RE-LABELLED DIGITAL T-STATS	CE	CE
C	ECN-CO-005274	3	CE	2022/02/10	NEW LIGHTS	CE	CE
D	ECN-CO-001874	4	CE	2023/01/26	CHANGED FANS & LIGHTS	CE	CE

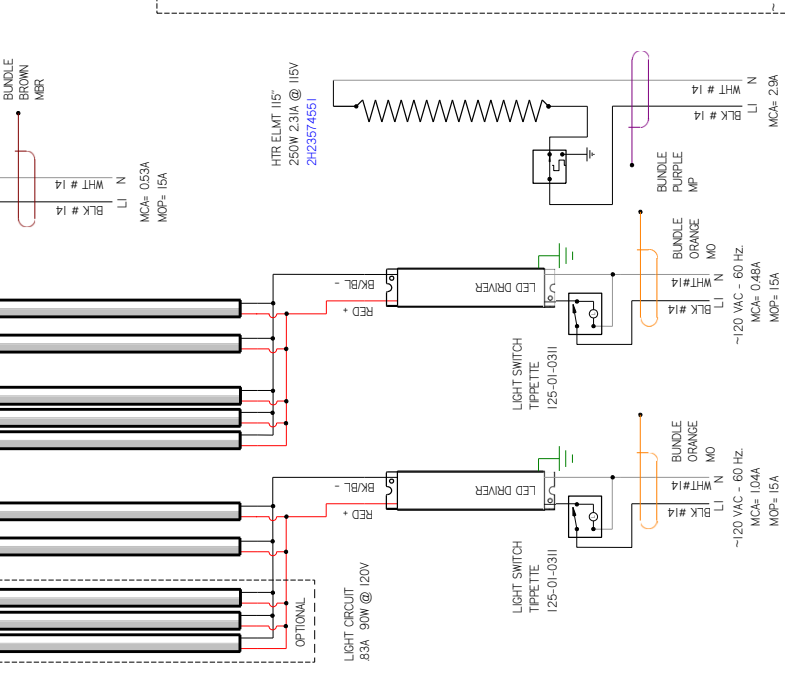
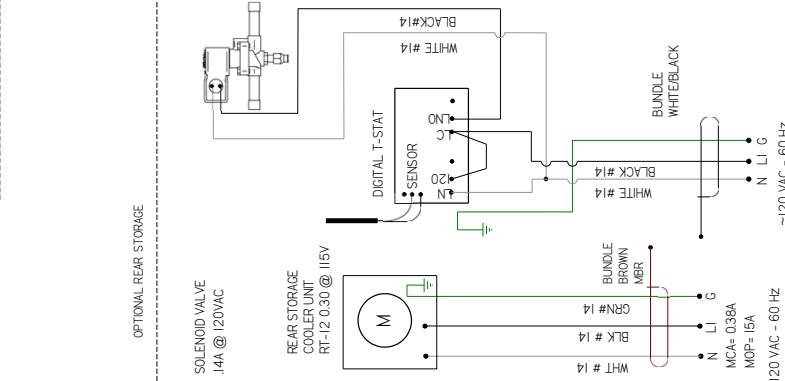
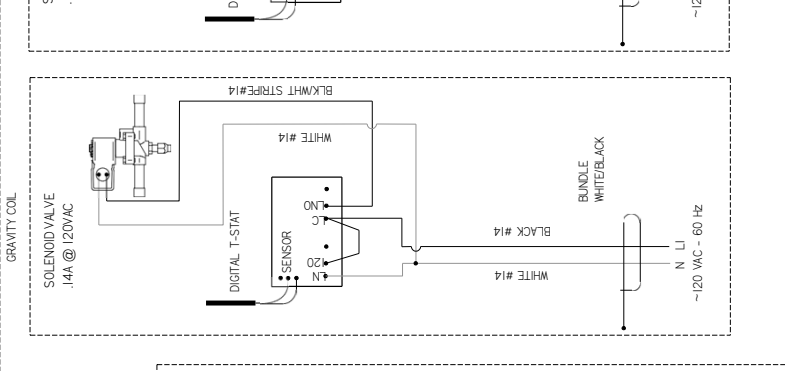
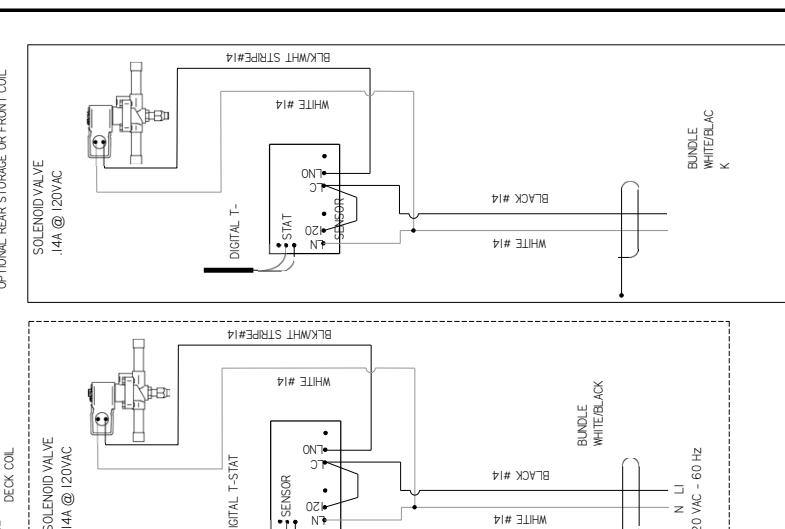
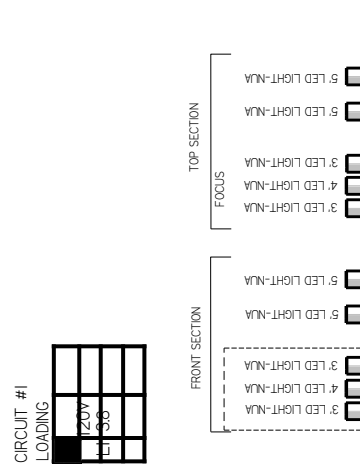
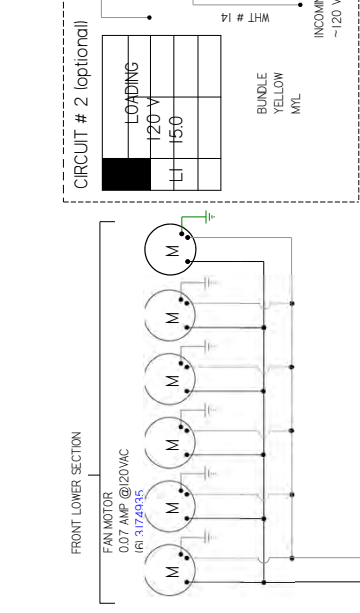
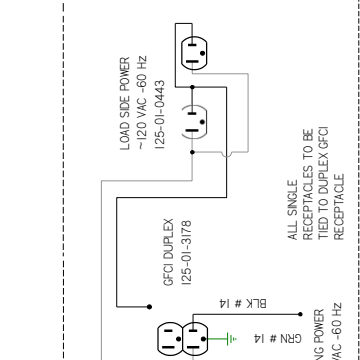

HUSSMANN

DATE DRAWN - 3-16-17
DRAWN BY - CRAIG BOOREY
REVIEWED BY - CRAIG BOOREY
APPROVED BY - CRAIG BOOREY

ECN-CAP-000848-12
DIAGRAM= YR3-FV-M7

REF= F-EP-10-R

SHEET NO. 1
TOTAL SHEETS 3

UNLESS OTHERWISE SPECIFIED DIMENSIONS ARE IN INCHES
TOLERANCES ARE:
FRACTIONS .005
DECIMALS .XX ±03 .XXX
ANGLES ± 2°

PROJECTION

3028818 | D

NOTES:
CASE MUST BE GROUNDED
WHEN PASSING WIRES THROUGH METAL HOLES A GROMMET MUST BE USED

REV	EN	DATE	REVISION DESCRIPTION	REV BY	CHK BY	APPR BY
A	ECN-CAP-0003964	2016/09/08	RELEASED TO PRODUCTION	CB	CB	CB
B	ECN-CAP-0005979	2017/01/12	REVISED REAR STORAGE COIL	CB	CB	CB
C	ECN-CAP-0006209	2017/01/24	REVISED REAR STORAGE T-STAT	CB	CB	CB
D	ECN-COD-001845	2017/01/24	RE-LABELLED DIGITAL T-STATS	CB	CB	CB
E	ECN-COD-0015274	2017/01/24	NEW LIGHTS	CB	CB	CB
F	ECN-COD-0018714	2017/01/26	CHANGED FANS & LIGHTS	CB	CB	CB

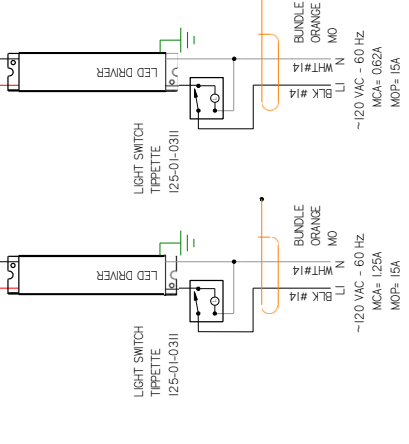
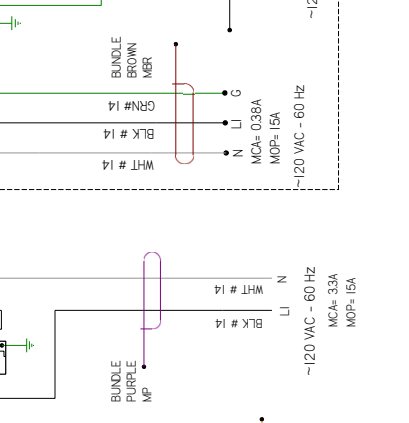
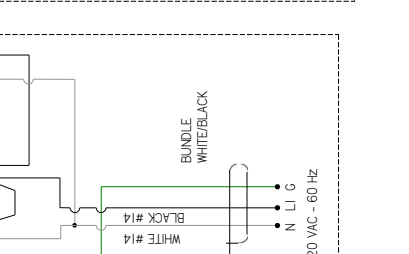
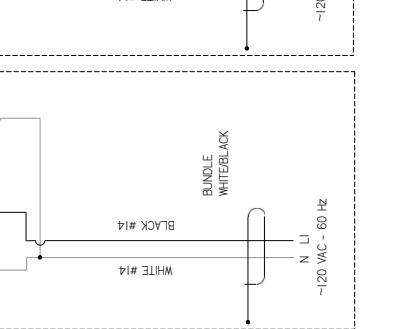
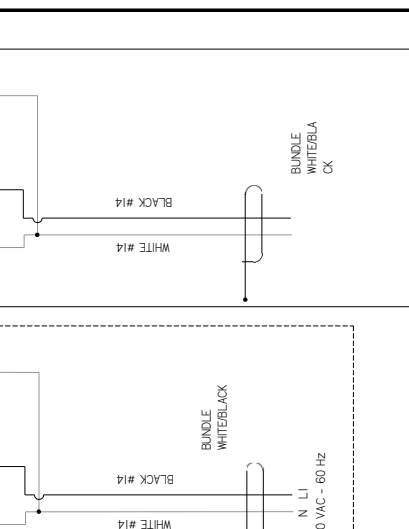
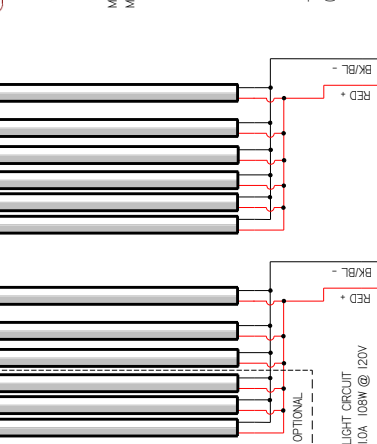
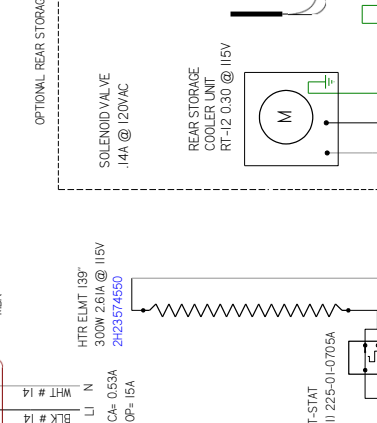
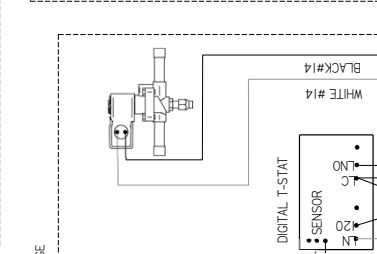
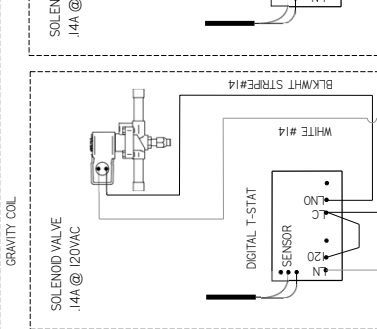
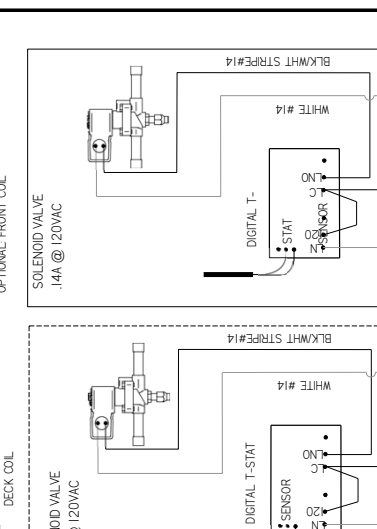
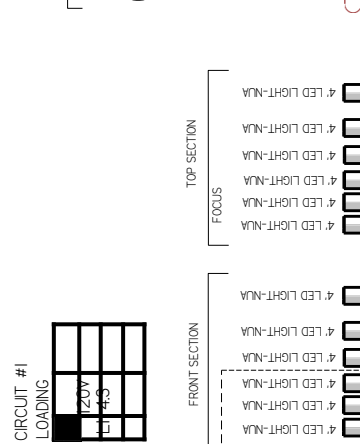
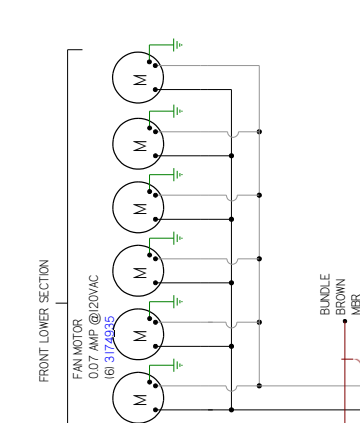
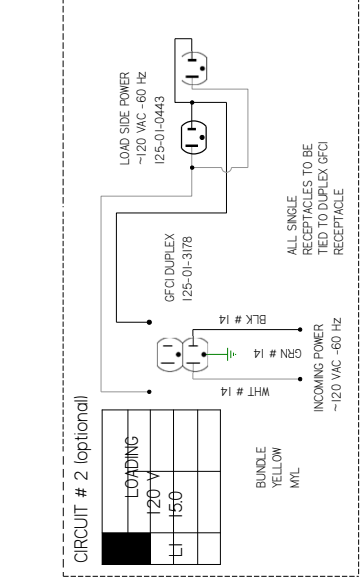

HUSSMANN
-120 VAC
DIAGRAM=VRSHV-MF
-EP-12R

MATERIAL - N/A
DATE DRAWN - 9-9-16
DRAWN BY - CRAIG BOOREY
REVIEWED BY - CRAIG BOOREY
APPROVED BY - CRAIG BOOREY
SHEET NO. 1
UNLESS OTHERWISE SPECIFIED DIMENSIONS ARE IN INCHES
TOLERANCES ARE:
DECIMALS .XX +0.03 .XXX
ANGLES ± 2°

PROJECTION
E
F

NOTES:
CASE MUST BE GROUNDED
WHEN PASSING WIRES THROUGH METAL HOLES A GROMMET MUST BE USED

REV	ECN	DATE	REVISION DESCRIPTION	REV BY	CHKD BY	APPR BY
1	ECN-CAP-0003964	2016/09/08	RELEASED TO PRODUCTION	CB	CB	CB
2	ECN-CAP-0005979	2017/01/2	REVISED REAR STORAGE COIL	CB	CB	CB
3	ECN-CAP-0006209	2017/01/24	REVISED REAR STORAGE T-STAT	CB	CB	CB
4	ECN-COD-0010445	2017/01/24	RE-LABELLED DIGITAL T-STAT	CB	CB	CB
5	ECN-COD-0015274	2018/02/19	NEW LIGHTS	CB	CB	CB
6	ECN-COD-0015274	2018/02/19	CHANGED FANS LIGHTS	CB	CB	CB
7	ECN-COD-0018714	2022/01/26		CB	CB	CB

CIRCUIT #1	LOADING
120V	
150V	

CIRCUIT #2	LOADING
120V	
150V	

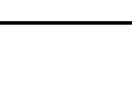
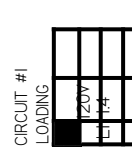
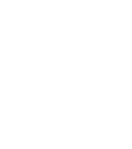
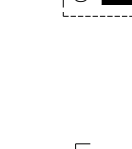
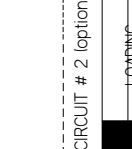
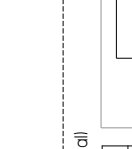

REV	EN	DATE	REVISION DESCRIPTION	REV BY	CHK BY	APPR BY
A	ECN-CAP-0003964	2016/09/08	RELEASED TO PRODUCTION	CB	CB	CB
B	ECN-CAP-0005978	2017/01/12	REVISED REAR STORAGE COIL	CB	CB	CB
C	ECN-CAP-0006209	2017/01/24	REVISED REAR STORAGE T-STAT	CB	CB	CB
D	ECN-COD-0010445	2017/01/12	RE-LABELLED DIGITAL T-STATS	CB	CB	CB
E	ECN-COD-0015274	2017/01/10	NEW LIGHTS	CB	CB	CB
F	ECN-COD-0018714	2017/01/26	CHANGED FANS BLIGHTS	CB	CB	CB

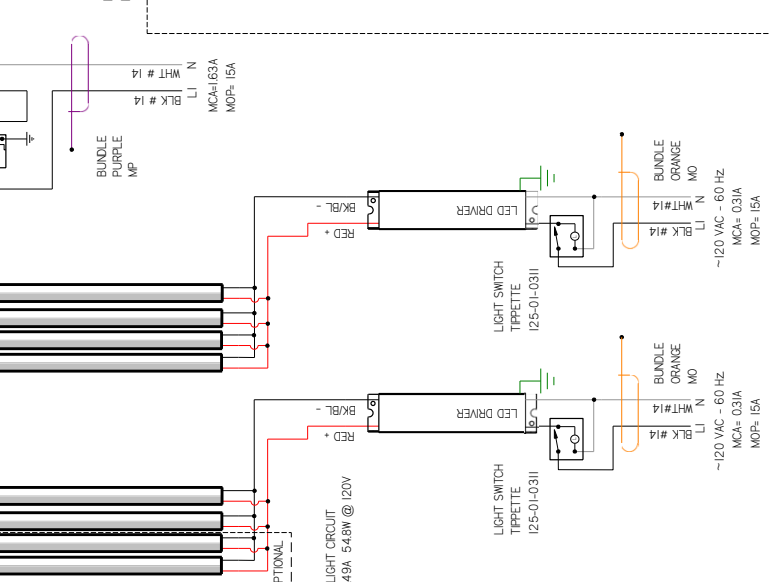
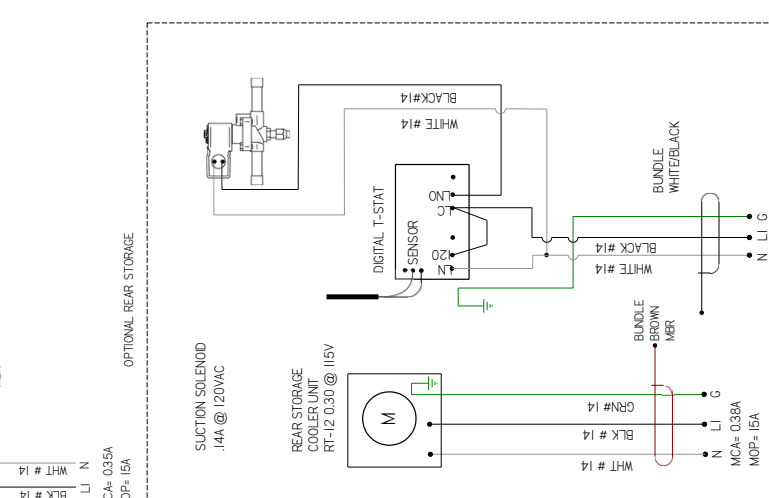
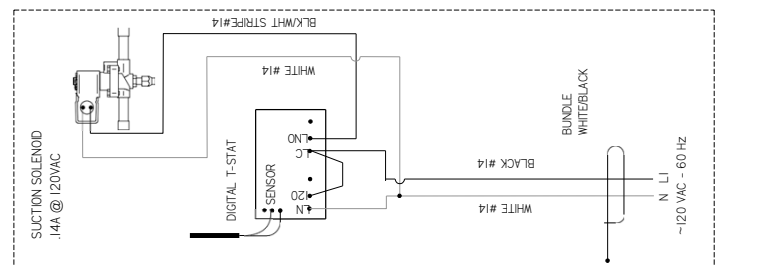
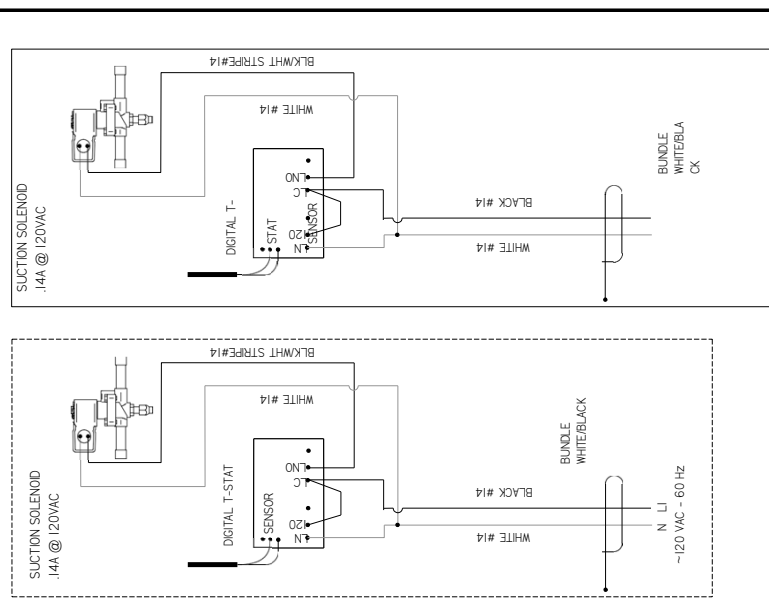
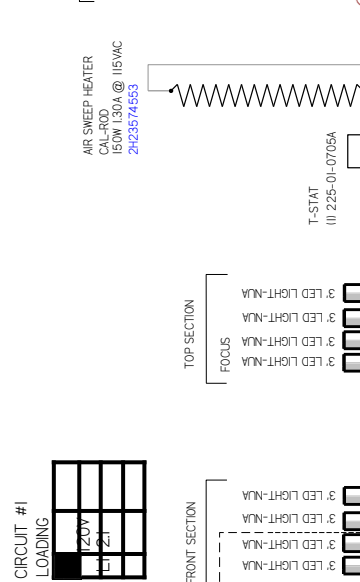
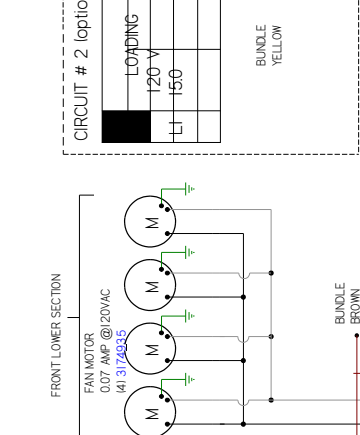
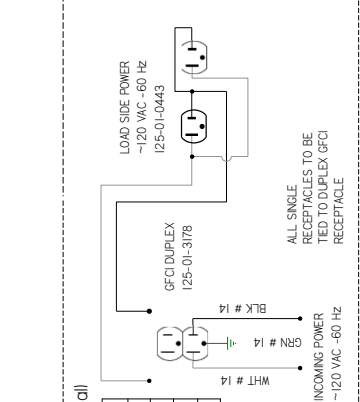

HUSSMANN
DATE DRAWN - 9-9-16
DRAWN BY - CRAIG BOOREY
APPROVED BY - CRAIG BOOREY
UNLESS OTHERWISE SPECIFIED DIMENSIONS ARE IN INCHES
DECIMALS .XX +03 .XXX
+0.0

REF -
SHEET 1 OF 1
DIAGRAM=VR3-MF-EP-6R

PROJECTION
E
ANGL
THRU

3014731 | F

NOTES:
CASE MUST BE GROUNDED
WHEN PASSING WIRES THROUGH METAL HOLES A GROMMET MUST BE USED

REV	EN	DATE	REVISION DESCRIPTION	REV BY	CHK BY	APPR BY
A	ECN-CAP-0003964	2016/09/08	RELEASED TO PRODUCTION	CB	CB	CB
B	ECN-CAP-0005979	2017/01/12	REVISED REAR STORAGE COIL	CB	CB	CB
C	ECN-CAP-0006209	2017/01/24	REVISED REAR STORAGE T-STAT	CB	CB	CB
D	ECN-COD-0010465	2017/01/24	RE-LABELLED DIGITAL T-STATS	CB	CB	CB
E	ECN-COD-0015274	2017/01/24	NEW LIGHTS	CB	CB	CB
F	ECN-COD-0018714	2017/01/26	CHANGED FANS BLIGHTS	CB	CB	CB

CIRCUIT #1	LOADING
120V	
2.7	

CIRCUIT #2	LOADING
120V	
15.0	

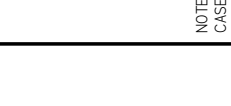
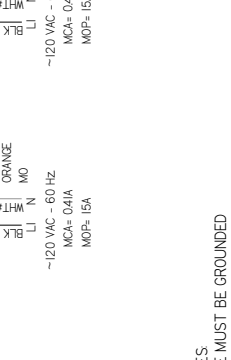
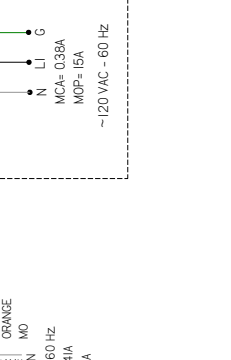
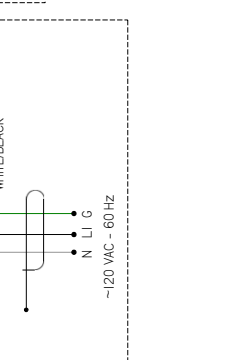
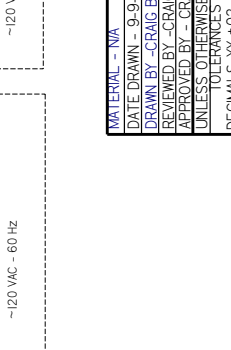
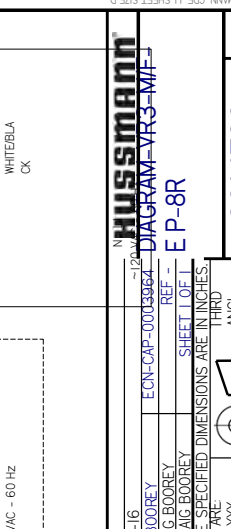
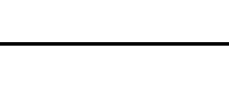
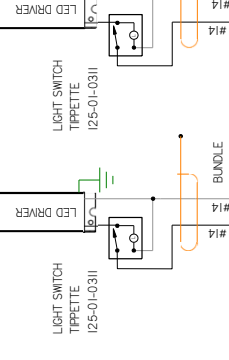
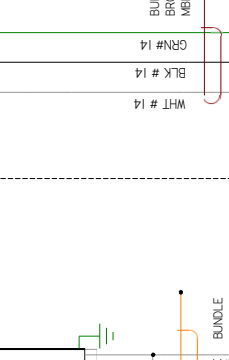
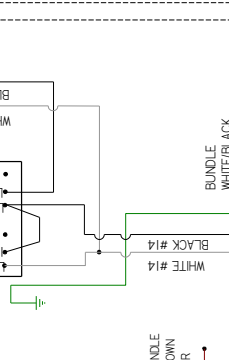
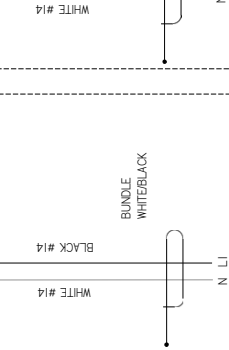
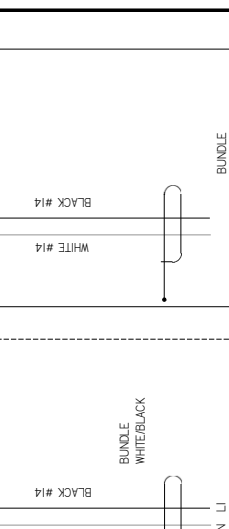
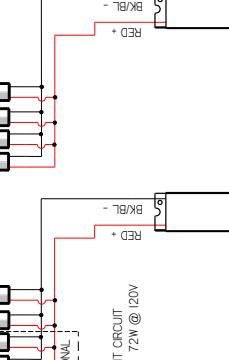
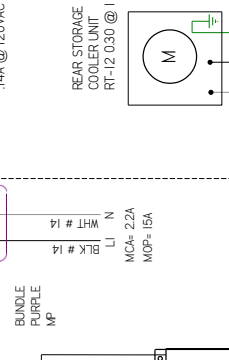
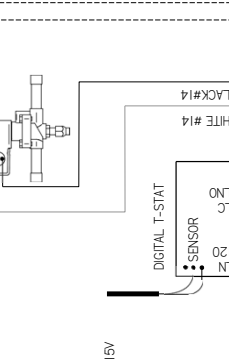
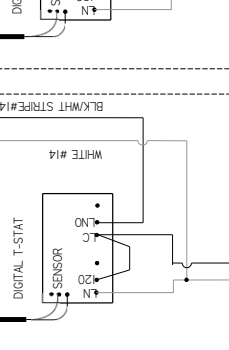
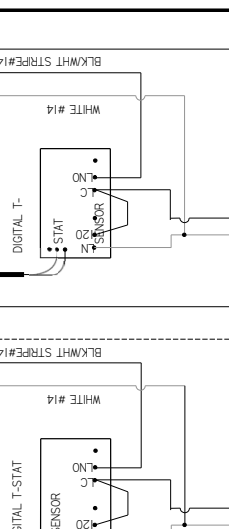
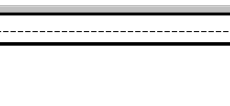
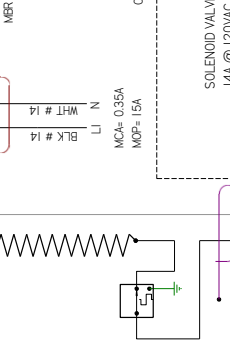
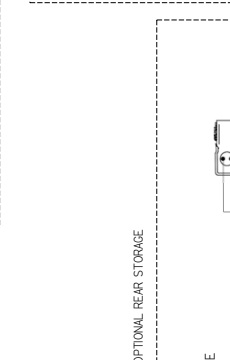
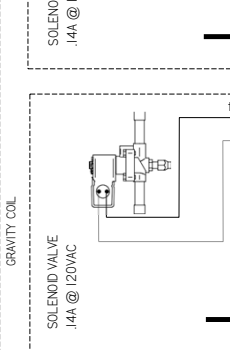
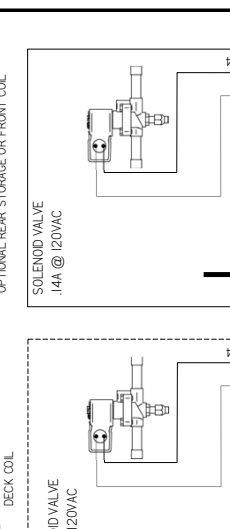
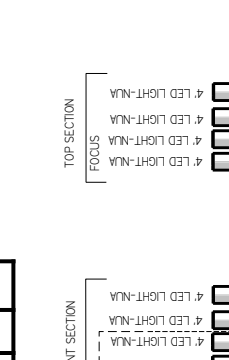
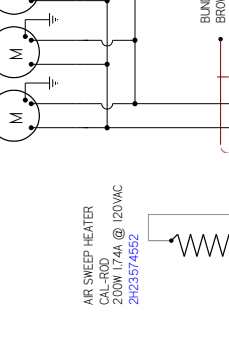
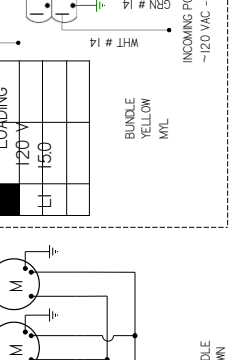
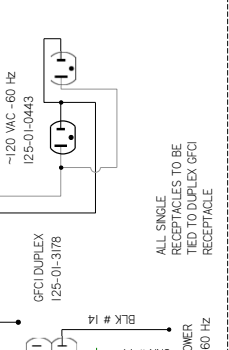
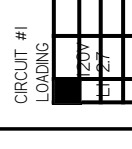
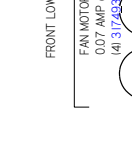
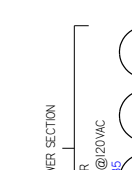
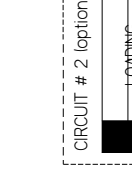
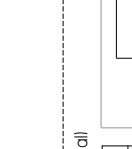

HUSSMANN
DATE DRAWN - 9-9-16
DRAWN BY - CRAIG BOOREY
REVIEWED BY - CRAIG BOOREY
APPROVED BY - CRAIG BOOREY
UNLESS OTHERWISE SPECIFIED DIMENSIONS ARE IN INCHES
TOLERANCES ARE:
DECIMALS .XX +.03 .XXX
ANGLES ± 2°

ECN-CAP-0003964
DIAGRAM-VR3-MF-EP-8R

SHEET 1 OF 1
THIRD PROJECTION

3014730 | F

NOTES:
CASE MUST BE GROUNDED
WHEN PASSING WIRES THROUGH METAL HOLES A GROMMET MUST BE USED

User Information

Start Up

See the merchandisers Data Sheet Set for refrigerant settings and defrost requirements. Bring merchandisers down to the operating temperatures listed on the Data Sheet before loading product into merchandiser.



WARNING

--LOCK OUT/TAG OUT--

To avoid serious injury or death from electrical shock, always disconnect the electrical power at the main disconnect when servicing or replacing any electrical component. This includes, but is not limited to, such items as doors, lights, fans, heaters, and thermostats.

Load Limit

Each Merchandiser has a Load Limit. Shelf life of perishables will shorten if Load Limit is violated.

AT NO TIME SHOULD THE MERCHANDISER BE STOCKED BEYOND THE LOAD LIMITS INDICATED.

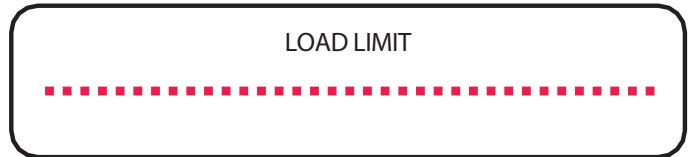

Basic Operation

The VR3-M/F-EP series case cools meat/fish in two ways:

1. The Spiral Deck Coil under the display deck cools the meat/fish product by means of contact conduction.
2. The Gravity Coil cools the case and product via natural air convection.

Spiral Deck Coil is the **primary source** of refrigeration while the Gravity Coil acts as a secondary source. Slow moving air circulation from the Gravity Coil (GC) and cold contact with the Spiral Coil (SC) on the deck combine to cool the product and keep product dehydration low. This balance is critical to achieve the expected display life and product temperature. If the product is lifted off of the deck surface by an aftermarket display shelf, reduced contact surface trays, or other means, the benefit of conduction cooling from the deck Spiral Coil is reduced dramatically.

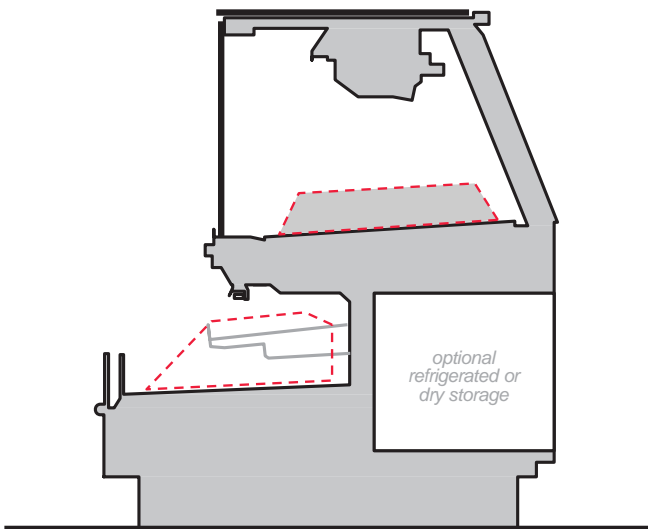

User Information (cont'd)

Merchandising Requirements

Use a consistent display strategy in each case. Hussmann recommends the use of flat bottomed aluminum or high density plastic trays as the ideal merchandising display method.

When displaying product on flat trays directly on the deck surface (ideal display method), layer product single or double high keeping product within the load limits (page 35). This promotes even cooling from both the spiral deck coil below and gravity coil above, and allows for less refrigeration power, lower dehydration and increased product life.



Rotate product every several hours. Bottom layer should be rotated to the top and flipped. This ensures even cooling, dehydration and color maintenance.

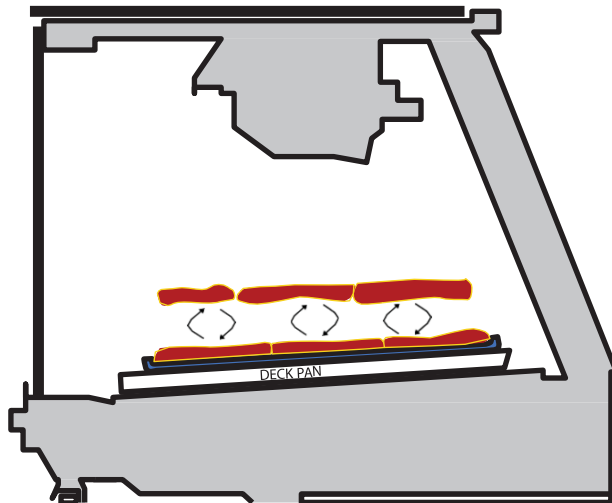

As demonstrated below, each layer of product has a slight increase in internal product temperature the higher it is stacked. It is very important that each layer make direct contact with the layer below it. With conductive cooling, heat will flow from the warmer surface to the cooler surface until both are nearly at the same temperature.

Deck Temperature (DT)

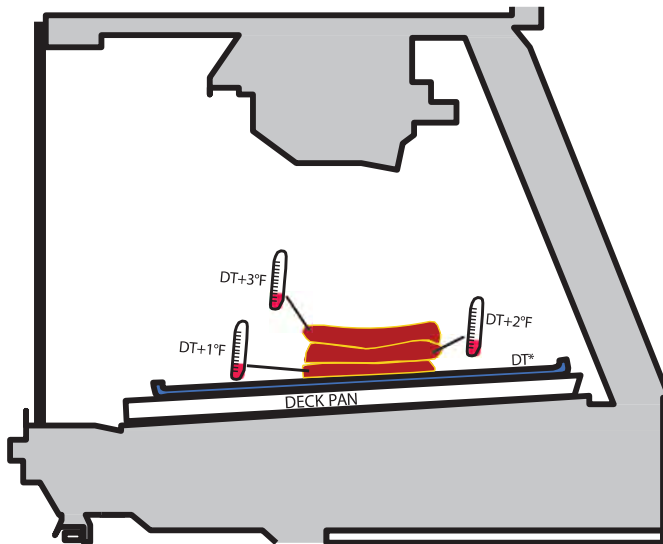

* DT will vary based on store conditions and case set points.

User Information (cont'd)

Merchandising DON'TS

Products can be stacked too high on trays or display ware, the Spiral serpentine coil underneath the deck pans are the main source for cooling for the case. If you are not achieving the internal product temperature your store desires, remove one layer. Monitor product interval temperatures for several hours.

By no means use Foam, polycarbonate, wood, synthetic solid surface materials or any other product partition which acts as an insulator to display product.

When separating product from direct contact preferably refer to Butcher Paper if desired.

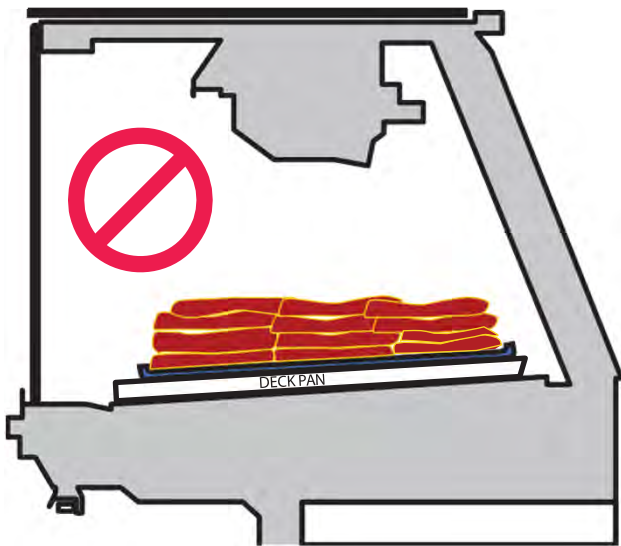

Display ware used inside a VR3HV-M/F-EP **MUST BE FLAT BOTTOMED** to make direct contact with the cooled deck pans, keep in mind that most display ware is designed with ridge along the bottom end or ridges across the surface bottom for structural support. Often times display ware has feet on the bottom of it to prevent direct contact with the display pan. Refrain from using any display ware which prevents direct contact between the display ware bottom and the cooled display pans. Any air space between the Hussmann opticold deck pans, the display ware or the product will adversely affect case performance and cause elevated product temperature and early product loss.

The following Display Wares or display configurations are **NOT RECOMMENDED** and working outside of the Hussmann requirements will adversely affect product and/or case performance.

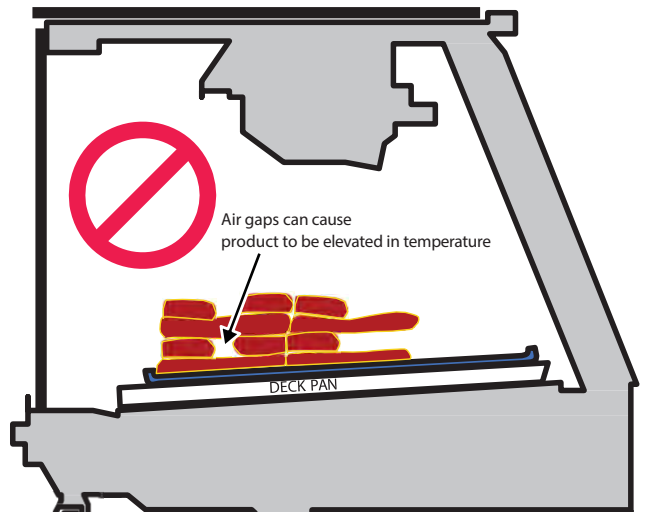
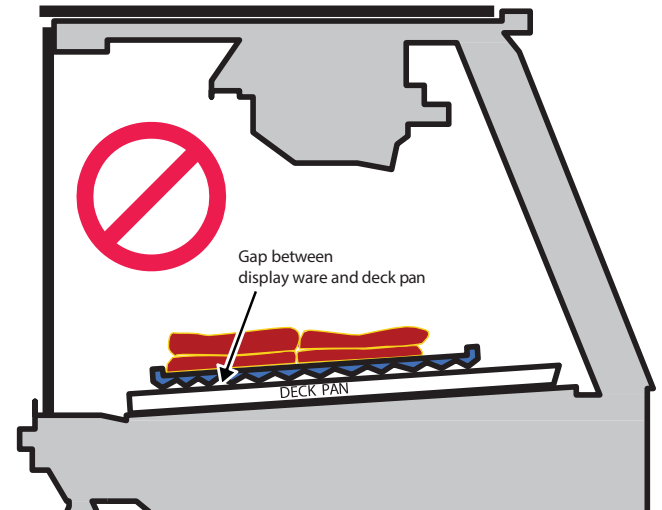
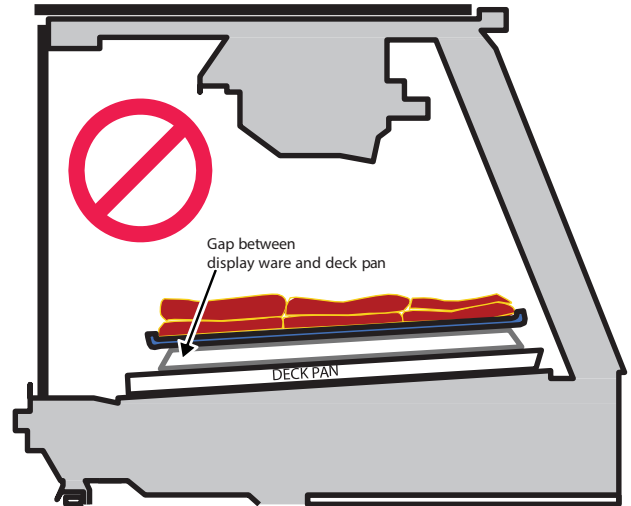

Maintenance

Case Cleaning

Long life and satisfactory performance of any equipment are dependent upon the care it receives. To insure long life, proper sanitation and minimum maintenance costs, the merchandiser should be thoroughly cleaned, all debris removed and interiors washed down, weekly.



TO PREVENT INJURY ALWAYS SHUT OFF POWER DURING CLEANING PROCESS.

Exterior Surfaces

The exterior surfaces must be cleaned with a mild detergent without chloride and warm water to protect and maintain their attractive finish. **NEVER USE ABRASIVE CLEANSERS OR SCOURING PADS.**

Cleaning Bumpers

Clean Bumpers with household spray cleaners.

Cleaning Under Merchandiser

Remove lower body panels. Use a vacuum with a long wand attachment to remove accumulated dust and debris from under the merchandiser.

Cleaning Stainless Steel Surfaces

Use non abrasive cleaning materials, and always polish with the grain of the steel. Use warm water or add a mild detergent to the water and apply with a cloth. Always wipe dry after wetting.

Use non-chlorine containing cleaners such as window cleaners and mild detergents. Do not use cleaners containing salts as this may cause pitting and rusting of the stainless steel finish. Do not use bleach.

Clean frequently to avoid build-up of hard, stubborn stains. A stainless steel cleaning solution may be used periodically to minimize scratching and remove stains. Rinse and wipe dry immediately after cleaning. Never use hydrochloric acid (muriatic acid) on stainless steel.

Interior Surfaces

The interior surfaces may be cleaned with most domestic detergents, ammonia based cleaners and sanitizing solutions that do not contain chloride with no harm to the surface.

Cleaning Coils

NEVER USE SHARP OBJECTS AROUND COILS.

Use a soft brush or vacuum brush to clean debris from coils. Do not puncture Coils! Do not bend fins. Contact an authorized service technician if a coil is punctured, cracked, or otherwise damaged.

Recommended Cleaning Schedule

Follow the schedule listed below for optimal sanitation and case performance. Exterior and Interior cleaning will be cleaned varying on upkeep of the merchandiser through daily use.

Merchandiser Deck & Drain Area: Once a week minimum.

Gravity Coil & Drip Tray: Once a month minimum.

ICE in or on the coil indicates the refrigeration and defrost cycle is not operating properly. Contact an authorized Service Technician to determine the cause of icing and to make proper adjustments as necessary. To maintain product integrity, if not done so already, move all product to a cooler until the merchandiser has returned to normal operating temperatures.

Maintenance Cont'd

Do Not Use:

- Abrasive cleaners and scouring pads, as these will damage the finish.
- A hose on lighted shelves or submerge lighted shelves in water.
- Solvent, oil or acidic based cleaners on any interior surfaces.
- A hose on LED Lights or any other electrical component.

IT IS NOT REQUIRED TO RAISE THE DECK SPIRAL COIL ASSEMBLY DURING CLEANING.

The case can be cleaned after removing the deck pan and alum tray. Nothing else needs to be moved or lifted.

Do:

- Remove the product and all loose debris to avoid clogging the waste outlet.
- Store product in a refrigerated area such as a cooler during the cleaning process. Remove only as much product as can be taken to the cooler in a timely manner.
- First Turn off Refrigeration, then disconnect electrical power to merchandiser.
- Thoroughly clean all surfaces with soap and hot water. Do not use steam or high pressure water hoses to wash the interior. These will destroy the merchandisers' sealing causing leaks and poor performance.
- Avoid direct contact between fan motors and cleaning or rinse water.
- Rinse with hot water, but DO NOT flood. Never introduce water faster than the waste outlet can drain.
- Allow merchandiser to completely dry before resuming operation.
- LED lights are magnetized to each shelf and can be removed easily for any shelf cleaning.
- After cleaning has been completed, remember to restore power back to merchandiser.



Prop 65 (CA Only)



This warning does not mean that Hussmann products will cause cancer or reproductive harm, or is in violation of any product-safety standards or requirements. As clarified by the California State government, Proposition 65 can be considered more of a 'right to know' law than a pure product safety law. When used as designed, Hussmann believes that our products are not harmful. We provide the proposition 65 Warning to stay in compliance with California state aw. It is your responsibility to provide accurate Proposition 65 Warning labels to your customers when necessary. For more information on Proposition 65, please visit the California State government website.

Troubleshooting

Problem	Possible Cause	Possible Solution
Product too cold and/ or freezing	Spiral Deck Coil (SDC) is too cold.	Probe the deck with the product in place. If the deck is less than 29°F increase the SDC thermostatic SP incrementally. Allow approximately 60 minutes or stable temperatures for system to react then recheck temperatures. Verify when SDC T-Stat is active that SDC is operating at desired Temperature/ Pressure (Evap Pressure).
	Gravity Coil (GC) set too cold	Increase thermostatic set point *(SP) of GC. Your setting will depend on store conditions and desired product temperature. The thermostatic SP is properly set when the product is ideally 33-38°F. Should ice be forming on the GC, verify Evaporator Pressure, GC Discharge Air (DA) is ranging between 33-36°F
	Excessive Icing	Ensure excessive icing condition's don't exist on SDC or that any exist on the GC
	Evaporator Suction Temperature	Ensure case evaporator / suction temperature is above 28°F.
	Superheat Set Too Low	Check superheat and adjust as necessary. See Case Specification
	T-Stat Sensor And TXV Bulbs Not Firmly Secured	Ensure that all T-Stat sensor and TXV bulbs are firmly secured to the pipes in the locations shown in figure (C). The bulbs should be at the 3 or 9 o'clock position on the pipe. Take care to insure SDC T-Stat sensor is below the surface of the Spiral Deck Tube (at mid tube from outer/inner of spiral) to insure no interference with Deck Plate. Band strap should be thin gauge copper. GC T-Stat sensor tip should be located approximately 1" below the bottom fin surface, at approximately coil center (front-back) and between 18"-24" from the end of the case wall. Ensure that the case is piped per the piping diagram (C) [Note: some components may be optional].
Product dehydrating prematurely	GC set too cold	Increase thermostatic SP of GC. Your setting will depend on store conditions and desired product temperature. The thermostatic SP is properly set when the DA from the GC is ranging between 33-37°F, depending upon Meat Department ambient conditions. Product should be turned and rotated about every 4 hours. Product should be covered at night with a clean, damp cloth such as cheese cloth if left in the display case overnight
Product too warm	Improper Case Piping	Verify case is properly piped per the Piping Diagram. Refer to Pipe Diagram
	Improper Suction Pressure Setting	Verify case suction pressure is set to a 28°F temperature equivalent when all Solenoid VLV are active/open

Troubleshooting Cont'd

Problem	Possible Cause	Possible Solution
	Improper Superheat Setting	Verify superheat. Adjust TX valves accordingly. Deck/Spiral coil may be set as low as 1-2° SH. Gravity coil may be set as low as 3° SH. (NOTE, when adjusting TXV superheat, first adjust the corresponding T-Stat below equivalent suction temperature. This will ensure that the T-Stat does not close during the adjustment period. Be sure to return T-Stat to SP.
Product too warm	Improper EPR Set Point	If SDC inlet temperature is above 28°F reduce the EPR set point
	Improper Thermostat Bulb Location	Ensure that the thermostat bulb for the gravity coil (A) is not contacting any coil parts and is located in the discharge air stream
	Improper TXV Bulb Location	Ensure that the TX valve bulbs are located as per the piping diagram. Refer to Pipe Diagram
	Improper Deck Plates (and Pans) Sitting	Ensure that the deck plates (and pans) are seated and making good contact with the SDC and each other
	Gravity Coil Air Flow Obstruction	Ensure that gravity coil is fully cleared all the time
	Defrost Failure To Clear All SDC Ice Buildup	The SDC will eventually pack with ice and refrigeration performance will be severely degraded. Confirm Evaporator Temperature is 28°F, SDC T-Stat SP to specification, and SDC termination temperature reaching at least 42°F. Increase the defrost time in 5 minute increments if this condition is observed, and termination temperature not achieved.
	Improperly sized refrigerant lines	Ensure that refrigerant lines are properly sized per the installation manual. Inspect liquid line for kinks, pinched or excessive u-bends
	Solid Column Of Liquid Refrigerant NOT reaching the TXV	Inspect liquid line for kinks, pinched or excessive u- bends.
	Liquid Refrigerant case inlet Temperature is excessive	Ensure that the liquid refrigerant entering temperature is not excessive. Liquid greater than 110°F at 6" ahead of the TXV may be an indication of equipment problems
	Product Introduction Temperature Too High	Correct product introduction temperature should be 34°F.-36°F.
	Product Is Stacked Too High	Reduce display height of product. Less than 6" is recommended
	Product is displayed in containers that impede the conduction cooling from the SDC	Use containers with full length, flat bottoms. Refer to MERCHANDIZING RECOMMENDATIONS (page 29) section for further information.
Incorrect replacement lighting is adding too much heat	Use only Hussmann genuine replacement parts or equivalent.	

Troubleshooting Cont'd

Problem	Possible Cause	Possible Solution
Case temperature is too warm.	Ambient conditions may be affecting the case operation.	Check case position in store. Is the case located near an open door, window, electric fan or air conditioning vent that may cause air currents? Case must be located minimum 15 Ft away from doors or windows. Cases are designed to operate at or below 75°F Dry bulb and 55% relative humidity.
	Discharge air temp is out of spec.	Check suction pressure and insure that it meets factory specifications.
	Case is in defrost.	Check defrost settings. See Technical Specifications section.
	Product load may be over its limits blocking airflow.	Redistribute product so it does not exceed load level.
Case temperature is too cold.	The t-stat temp is set too low.	Check settings. See Technical Specifications section.
	Ambient conditions may be affecting the case operation.	Check case position in store. Is the case located near an open door, window, electric fan or air conditioning vent that may cause air currents? Case must be located minimum 15 Ft away from doors or windows. Cases are designed to operate at or below 75°F Dry bulb and 55% relative humidity.
Condensation on glass.	Ambient conditions may be affecting the case operation.	Check case position in store. Is the case located near an open door, window, electric fan or air conditioning vent that may cause air currents? Case must be located minimum 15 Ft away from doors or windows. Cases are designed to operate at or below 75°F Dry bulb and 55% relative humidity.
	There are glass gaps on the side of the case.	See glass adjustment section.
	Glass is not completely shut.	Close glass correctly.
	Ambient Conditions	Turn on Air Sweep Fans located at the right rear of merchandiser.
Water has pooled under case.	Case drain is clogged.	Clear drain.
	PVC drains under case may have a leak.	Repair as needed.
	Case tub has unsealed opening.	Seal as needed.
	If the case is in a line-up, case to case joint is missing or unsealed.	Install case to case joint and seal as needed.
	Evaporator pan is overflowing (if applicable).	Check electrical connection to evaporator pan. Check float assembly, it should move freely up and down the support stem. Clear any debris.
Case is not draining properly.	Case is not level.	Level the case.
	Drain screen is plugged.	Clean drain screen and remove any debris.
	Drain or P-trap is clogged.	Clear any debris.
Frost or ice on evaporator coil.	Defrost clock is not functioning.	Case should be serviced by a qualified service technician.

Troubleshooting Cont'd

Problem	Possible Cause	Possible Solution
Lights do not come on.	LED Driver /light wiring.	Check electrical connections. See Electrical Section and check wiring diagram.
	LED Driver needs to be replaced.	Case should be serviced by a qualified service technician. See Electrical Section.
	LED Light needs to be replaced.	Case should be serviced by a qualified service technician.
	Light Switch needs to be replaced.	Case should be serviced by a qualified service technician.



HUSSMANN[®]

To obtain warranty information
or other support, contact your
Hussmann representative.
Please include the model and
serial number of the product.

Hussmann Warranty / Technical Assistance
(800) 592-2060