

VR3/HV DELI/BAKERY SERVICE MERCHANDISER

U S E R M A N U A L

- VR3 - VR3-D/B-4-R - VR3HV-D/B-4-R
- VR3-D/B-6-R - VR3HV-D/B-6-R
- VR3-D/B-8-R - VR3HV-D/B-8-R
- VR3-D/B-12-R - VR3HV-D/B-12-R

Table of Contents

General Information	3	User Information	28
		Start Up	28
Case Sections	4	Load Limits	28
Installation	6	Maintenance	29
Receiving Case	6	Case Cleaning	29
Lifting and Transport	7	Exterior Surfaces	29
Drain Configuration	7	Interior Surfaces	29
Skid Removal	8	Troubleshooting	31
Lifting Points	8		
Dollie Placement	8		
Hardware Removal	8		
Level Case	9		
Leg Adjustment	9		
Joint Trim Packlist	10		
Setting and Joining	11		
Arm Adjustment	14		
Glass Adjustment	15		
Body Panels Install	16		
Refrigeration	17		
Refrigeration	17		
Refrigerant Piping	17		
Line Sizing	17		
Oil Traps	17		
Refrigerant Spec Sheet	19		
Electrical	20		
Merchandiser Electrical Data	20		
Electrical Connections	20		
Field Wiring	20		
Identification of Wiring	20		
Remove Rear Raceway	21		
Electrical Conduit (Electrical Box)	21		
Electrical Wiring Diagram	22		

General Information

Case Description:

Description: Refrigerated Service Deli Merchandiser

Shipping Damage: All equipment should be thoroughly examined for shipping damage before and during unloading. This equipment has been carefully inspected at our factory and the carrier has assumed responsibility for safe arrival. If damaged, either apparent or concealed, claim must be made to the carrier Immediately.

Apparent Loss or Damage: If there is an obvious loss or damage, it must be noted on the freight bill or express receipt and signed by the carrier's agent; otherwise, carrier may refuse claim. The carrier will supply necessary claim forms.

Concealed Loss or Damage: When loss or damage is not apparent until after all equipment is uncrated, a claim for concealed damage is made. Make request in writing to carrier for inspection within 15 days, and retain all packaging. The carrier will supply inspection report and required claim forms.

Shortages: Check your shipment for any possible shortages of material (See Parts List page 9). If a shortage should exist and is found to be the responsibility of Hussmann Chino, notify Hussmann Chino. If such a shortage involves the carrier, notify the carrier immediately, and request an inspection. Hussmann Chino will acknowledge shortages within ten days from receipt of equipment.

Hussmann Chino Product Control: The serial number and shipping date of all equipment have been recorded in Hussmann's files for warranty and replacement part purposes. All correspondence pertaining to warranty or parts ordering must include the serial number of each piece of equipment involved, in order to provide the customer with the correct parts.

Location/Store Conditions: The VR3HV refrigerated merchandiser has been designed for use only in air conditioned stores where temperature and humidity are maintained at or below 75°F Dry bulb and 55% relative humidity. DO NOT allow air conditioning, electric fans, ovens, open doors or windows (etc.) to create air currents around the merchandiser, as this will impair its correct operation.

Keep this booklet with the case at all times for future reference.

HUSSMANN®/CHINO

A publication of HUSSMANN® Chino
13770 Ramona Avenue • Chino, California 91710
(909) 628-8942 FAX
(909) 590-4910
(800) 592-2060

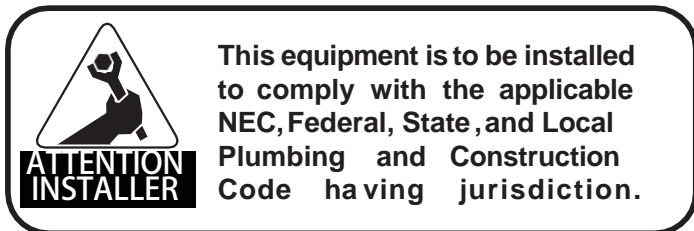

Case Sections VR3-D/B

VR3-D Vertical Glass
Standard Service Dome, Multi Deck Self Service

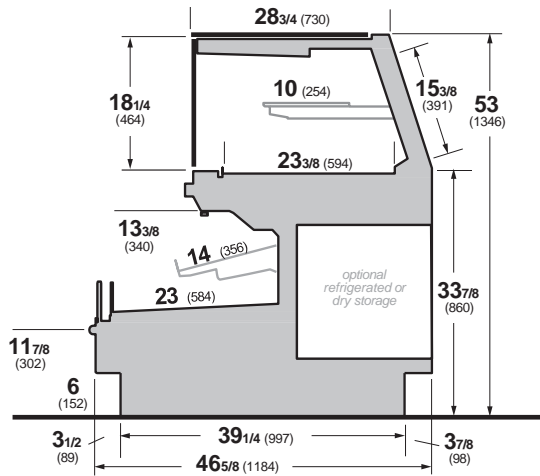

VR3-D+2 Vertical Glass
Standard Service Dome, Multi Deck Self Service +2 Height

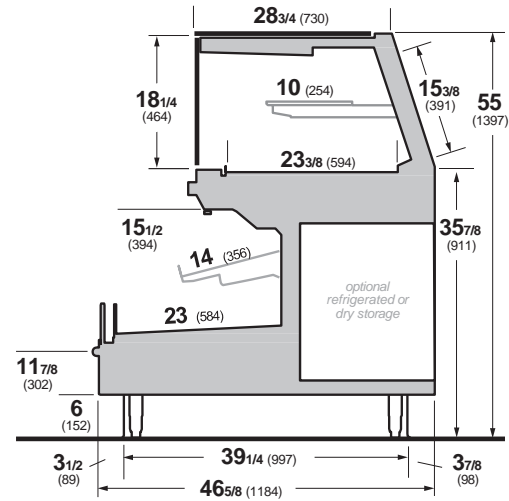

VR3-D+4 Vertical Glass
Standard Service Dome, Multi Deck Self Service +4 Height

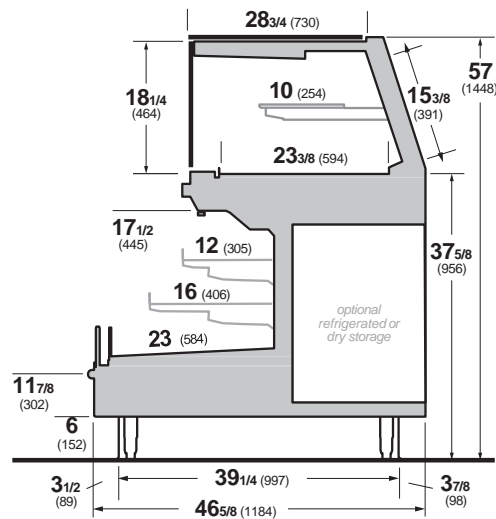

VR3-D, VR3-B

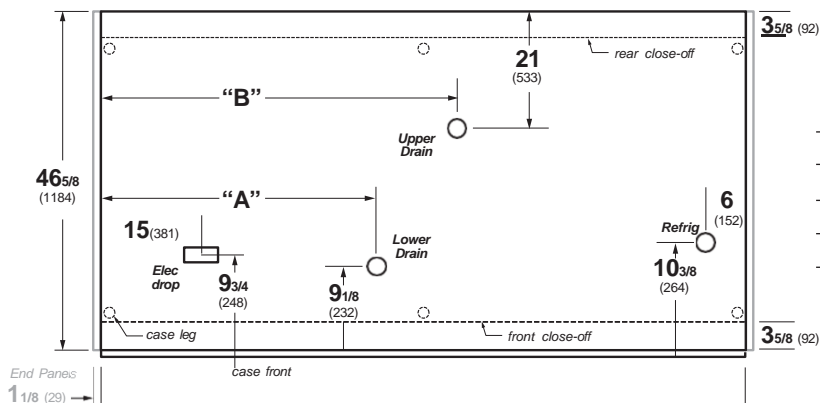

Length	"A"	"B"
4'	7 (178)	32 (813)
6'	41 (1041)	44 (1118)
8'	53 (1346)	56 (1422)
12'	65 (1651)	77 (1956)

Case Sections VR3HV-D/B

VR3HV-D Vertical Glass
High Volume Service Dome, Multi Deck Self Service

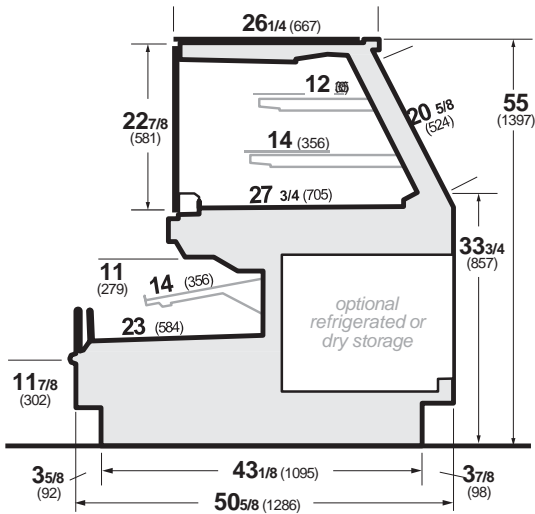

VR3HV-D +2 Vertical Glass
High Volume Service Dome, Multi Deck Self Service +2" height

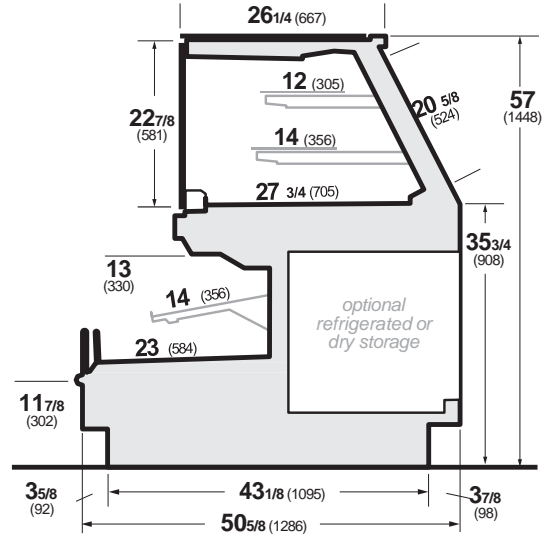

VR3HV-D -2 Vertical Glass
High Volume Service Dome,
Multi Deck Self Service -2" height

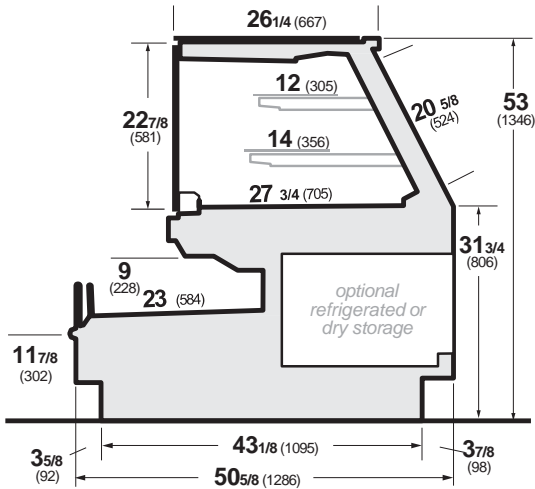

VR3HV-D, VR3HV-B

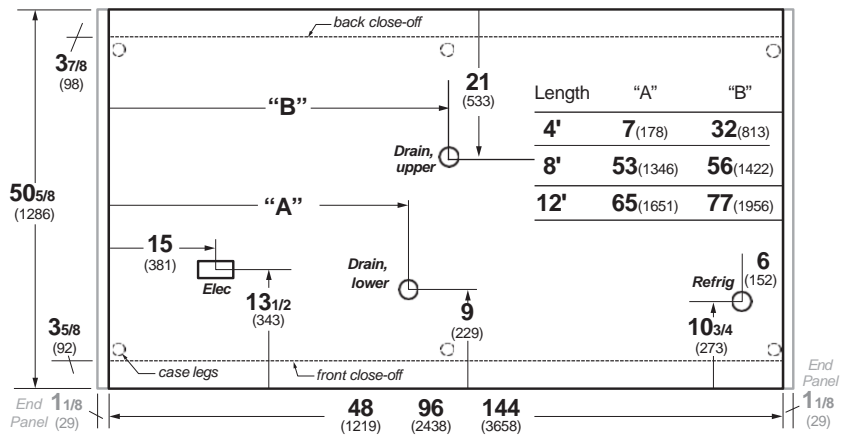

Unloading

NOTICE

Do NOT remove Foam Blocks from shelves and glass until the merchandisers are positioned for installation. Shelves or merchandising glass may be damaged.

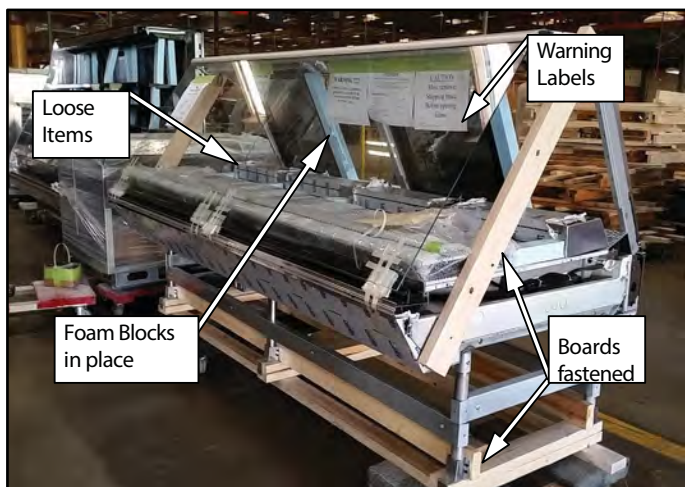

Case is to arrive at store as was shipped from factory. See reference above for proper shipment referencing. (Not actual case)

Receiving Case

Upon receiving your new Hussmann Case all equipment should be thoroughly examined for shipping damage before and during unloading. This equipment has been carefully inspected at our factory. Any claim for loss or damage must be made to the carrier. The carrier will provide any necessary inspection reports or claim form.

If there is obvious loss or damage, it must be noted on the freight bill or express receipt and signed by the carrier's agent; otherwise carrier may refuse claim.

Installation (cont'd)

VR3HV Lifting and Transport Instructions

1. The VR3HV-D can be lifted by a forklift at typical lifting points.
2. Ensure lower body panels are removed before lifting with a forklift. Serious damage will occur if the body panels are not removed. (Shipped loose from factory)
3. Make sure that fork spacing and width will not damage drain or come in contact with piping, or electrical lines
4. Be sure that the forks are long enough to support beyond the center of the case but not damage near components. Check for proper balance before moving. A minimum fork length of 36" is recommended for 68" wide cases

5. The VR3HV-D merchandiser can be raised at one end underneath the deck with a forklift or J-Bar if forklift is not accessible to allow the placement of rollers or dollies.
6. Evenly support the entire base structure on rollers or dollies before attempting to move. Each Base Leg must have its own dolly to properly support the case.

WARNING

Improper placement of forks may damage drainage piping. Use a spotter when placing forks. Make sure that piping will not be damaged. Use J-Bars or Jacks if forks cannot be used safely

Lifting Points are typical and dependent upon size of case and refrigeration application, drainage configurations will call for alterations in Lifting Zones.

Below are the following drainage configurations and lifting should be altered to the expected model.

VR3HV-D Drain Location

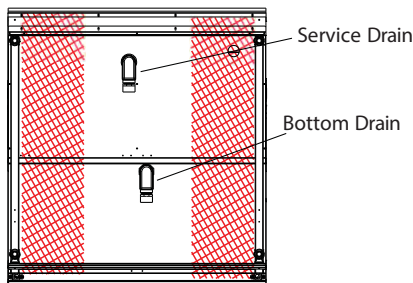

4' Case

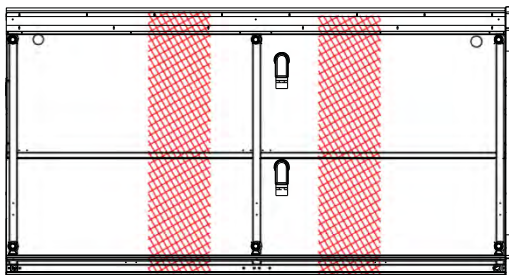

8' Case

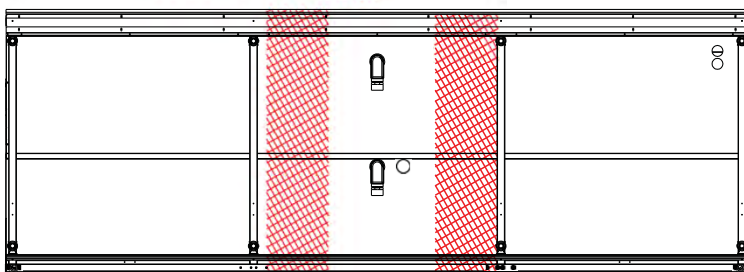

12' Case

Installation (cont'd)

Skid Removal

Important: See lifting instructions to properly lift case when being placed on dollies or permanent location. (See page 6 for Lifting Instructions.)

Lifting Points

Leave all hardware and fittings in place until case is located at or near its preferred location. Using forklift or J-Bar lift the case from the 2x4 boards and placing dollies underneath each base leg, proceed to moving the case to its designated location if not done so already.

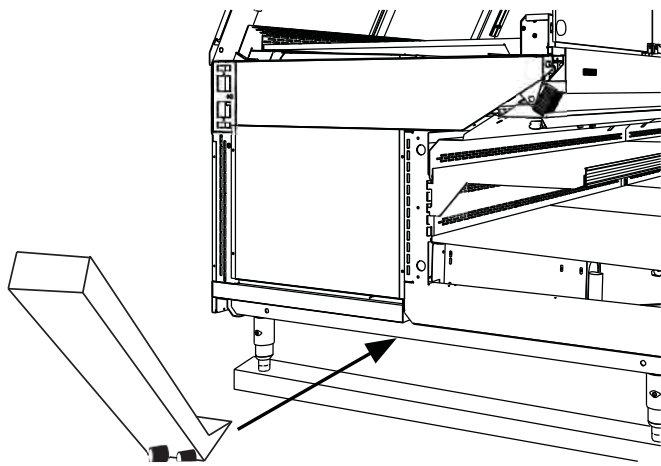

Dollie Placement

The illustration below demonstrates perfect placement of a dollie per 1 side for both base legs of the merchandiser.

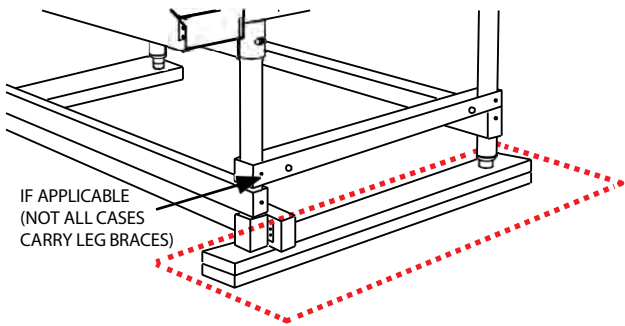

Move the fixture as close as possible to its permanent location and then remove all packaging and prepare to remove off Skid. Remove all separately packed accessories such as kits, and panels. Check for damage before discarding packaging.

Hardware Removal

Remove screws as well as fastened plates bolted to each 2x4 board at each base leg.

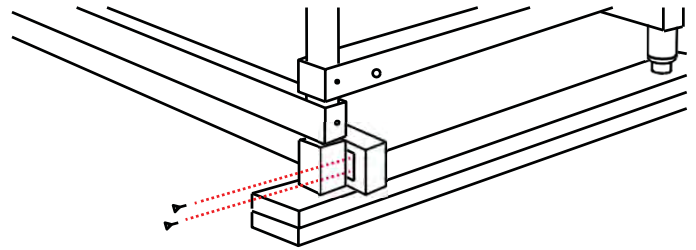

Remove fastened plates only upper brace legs are to remain fastened onto case.

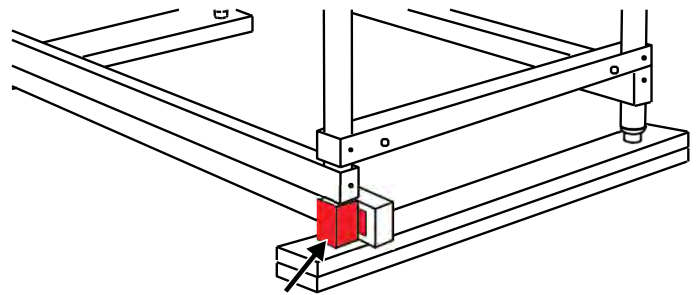

Fastened plate

Once the fastened plates are removed a J-Bar can be used to lift at each end of the leg braces to remove the below 2x4 boards.

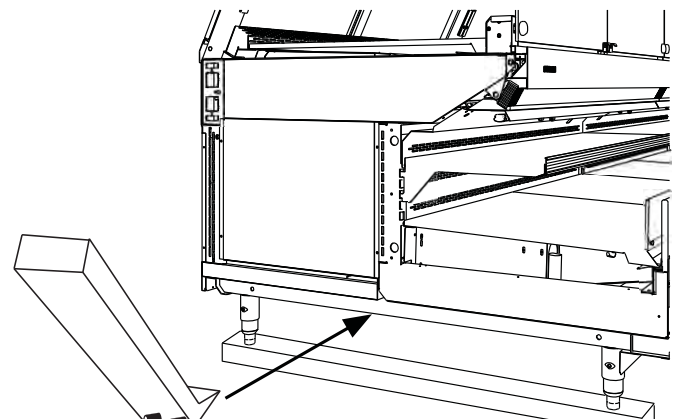

Installation (cont'd)

Level Case

Position the case at the highest point. Set a long magnetized level (4ft [1220 mm] or more) on either underneath the deck or on top of the case. Ensure to level case from front to back and side to side.

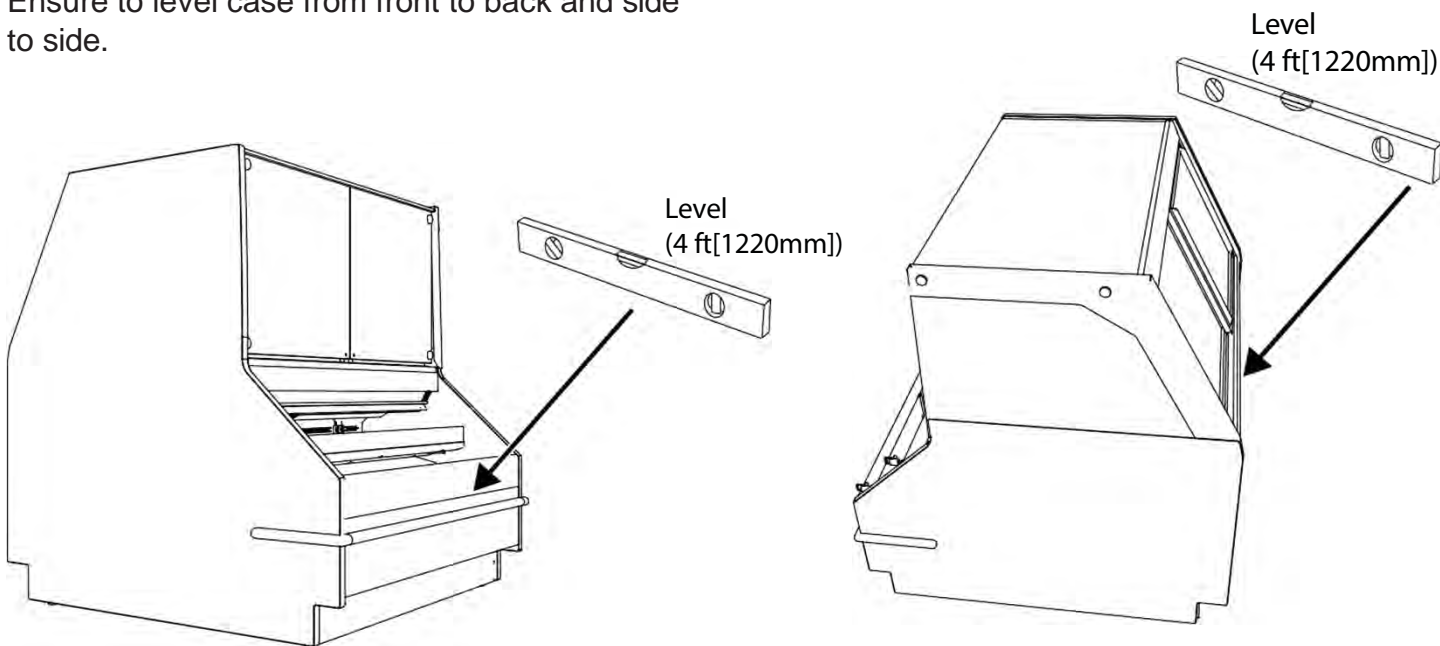

Leg Adjustment

Adjust the legs at each corner of the case to level out any discrepancies in order to optimize case performance and proper drainage.

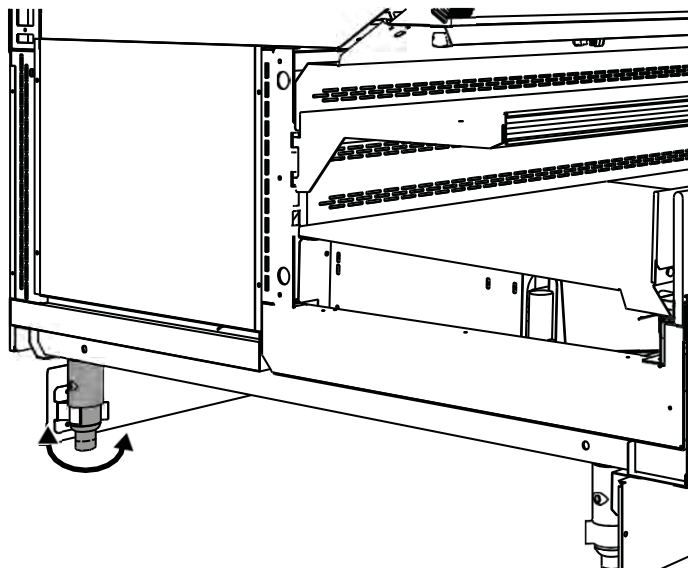

Note: To avoid removing concrete flooring, begin line up levelling from the highest point of the store floor.

A wrench or pliers may be used to adjust each base leg.

- Turning the base of each leg clockwise will lower the height of the case.
- Turning the base of each leg counter-clockwise will raise the height of the case.

Joint Trim Packlist

VR3HV/VR3/ JOINT CHECKSHEET

INSPECTOR _____
 SALES ORDER # _____
 EXT COLOR _____
 INT FINISH __SS__/_BLACK__

*SEE INSTALLATION GUIDE

 INDICATES CASE BOLTING/ALIGNMENT POINT

CHK	ITEM	PART #	QTY	GRAPHIC
<input type="checkbox"/>	FRONT BODY PANEL TRIM	2H20345 (STAINLESS) 2H20345 (EXT COLOR)	1	A
<input type="checkbox"/>	TOE KICK TRIM	TBD (EXT COLOR) TBD (STAINLESS)	1	B
<input type="checkbox"/>	SELF SERVICE BULKHEAD CAP	2H20347 (STAINLESS)	1	C
<input type="checkbox"/>	SERVICE BULKHEAD CAP	2H20348 (STAINLESS)	1	D
<input type="checkbox"/>	REAR ARM TRIM	2H20346 (STAINLESS)	1	E
<input type="checkbox"/>	REAR TOE KICK TRIM	2H20114 (STAINLESS)	1	F
<input type="checkbox"/>	UPPER FRONT BODY PANEL TRIM	2H20344 (EXT COLOR) 2H20344 (STAINLESS)	1	G
<input type="checkbox"/>	REAR UPPER RACEWAY TRIM	2H20350 (STAINLESS)	1	H
<input type="checkbox"/>	REAR LOWER RACEWAY TRIM	2H20351 (STAINLESS)	1	I
<input type="checkbox"/>	WASHER, 3/8"	300-03-1320	5	J
<input type="checkbox"/>	BOLT, 3/8 - 16 X 8	300-03-0902	2	K
<input type="checkbox"/>	GASKET SEAL TAPE	225-01-0628	16 FT	L
<input type="checkbox"/>	SEALANT, BUTYL, TUBE	100-01-0121	1	M
<input type="checkbox"/>	ALIGNMENT PIN	0376408	3	N
<input type="checkbox"/>	SPLINE H CHAN POLY 4 1/2	200-02-3022	1	O
<input type="checkbox"/>	JOINING NYLON WASHER	2H04205800	1	P
<input type="checkbox"/>	BOLT, 3/8 - 16 X 1.5	300-03-0850	3	Q
<input type="checkbox"/>	NUT, 3/8-16	300-03-1370	5	R
<input type="checkbox"/>	TRIM JOINT FRONT PLEX 6IN	2H21696 (EXT COLOR) 2H21696 (STAINLESS)	1	S
<input type="checkbox"/>	SEALANT, SILICONE, TUBE	100-01-0051 (CLEAR) 100-01-0063 (SILVER) 100-01-0065 (BLACK)	1	-
<input type="checkbox"/>	SCREW, SELF TAP #8 X 1/2	300-03-0037	12	-
<input type="checkbox"/>	VHB DOUBLE-SIDED TAPE	175-01-0562	16 FT	-
<input type="checkbox"/>	COUPLING, 2" PVC	225-01-0090	1	-

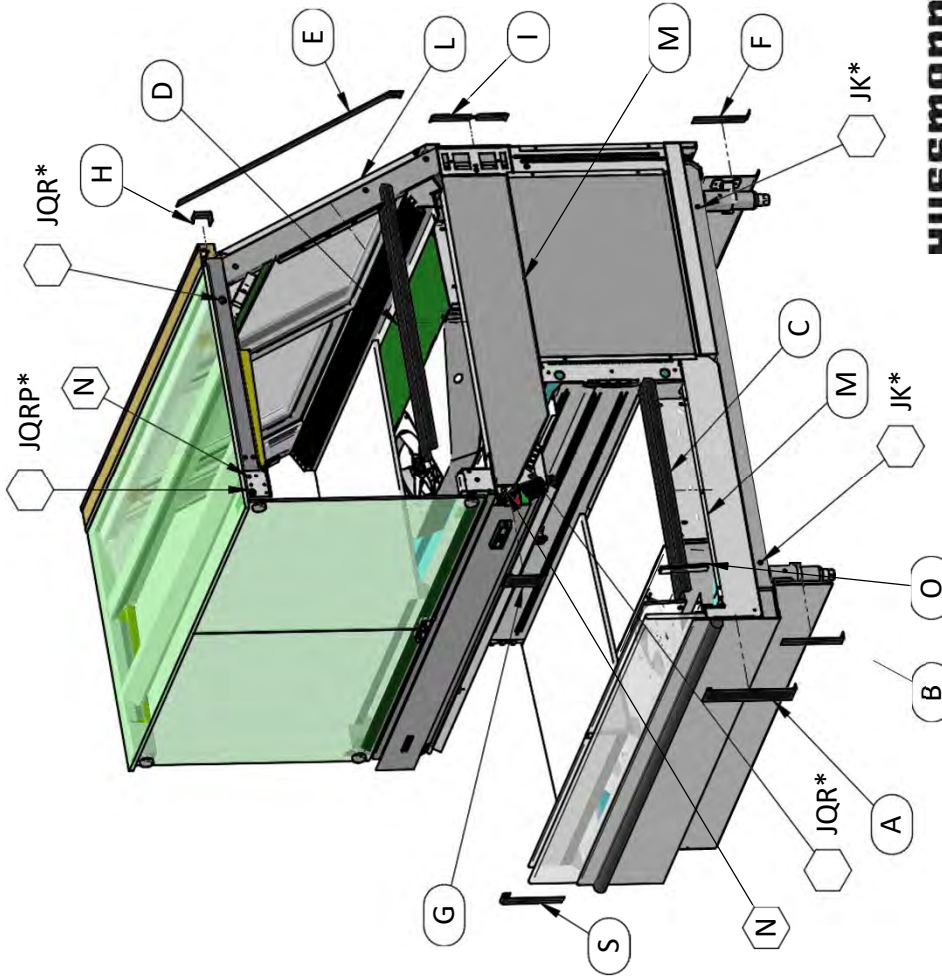

HUSSMANN
 REV E 01/21/2016

Installation (cont'd)

Setting and Joining

The sectional construction of these models enable them to be joined in line to give the effect of one continuous display.

An alignment pin kit is supplied with every case and must be used in alignment.

Leveling

IMPORTANT! IT IS IMPERATIVE THAT CASES BE LEVELED FROM FRONT TO BACK AND SIDE TO SIDE PRIOR TO JOINING. A LEVEL CASE IS NECESSARY TO INSURE PROPER OPERATION, WATER DRAINAGE, GLASS ALIGNMENT AND OPERATION OF THE HINGES SUPPORTING THE GLASS. LEVELING THE CASE CORRECTLY WILL SOLVE MOST HINGE OPERATION PROBLEMS.

Snapping Chalk Lines

Prepare permanent positioning by marking floors with Chalk snap lines where cases are to be located. Chalk lines are to run along the base or legs of cases.

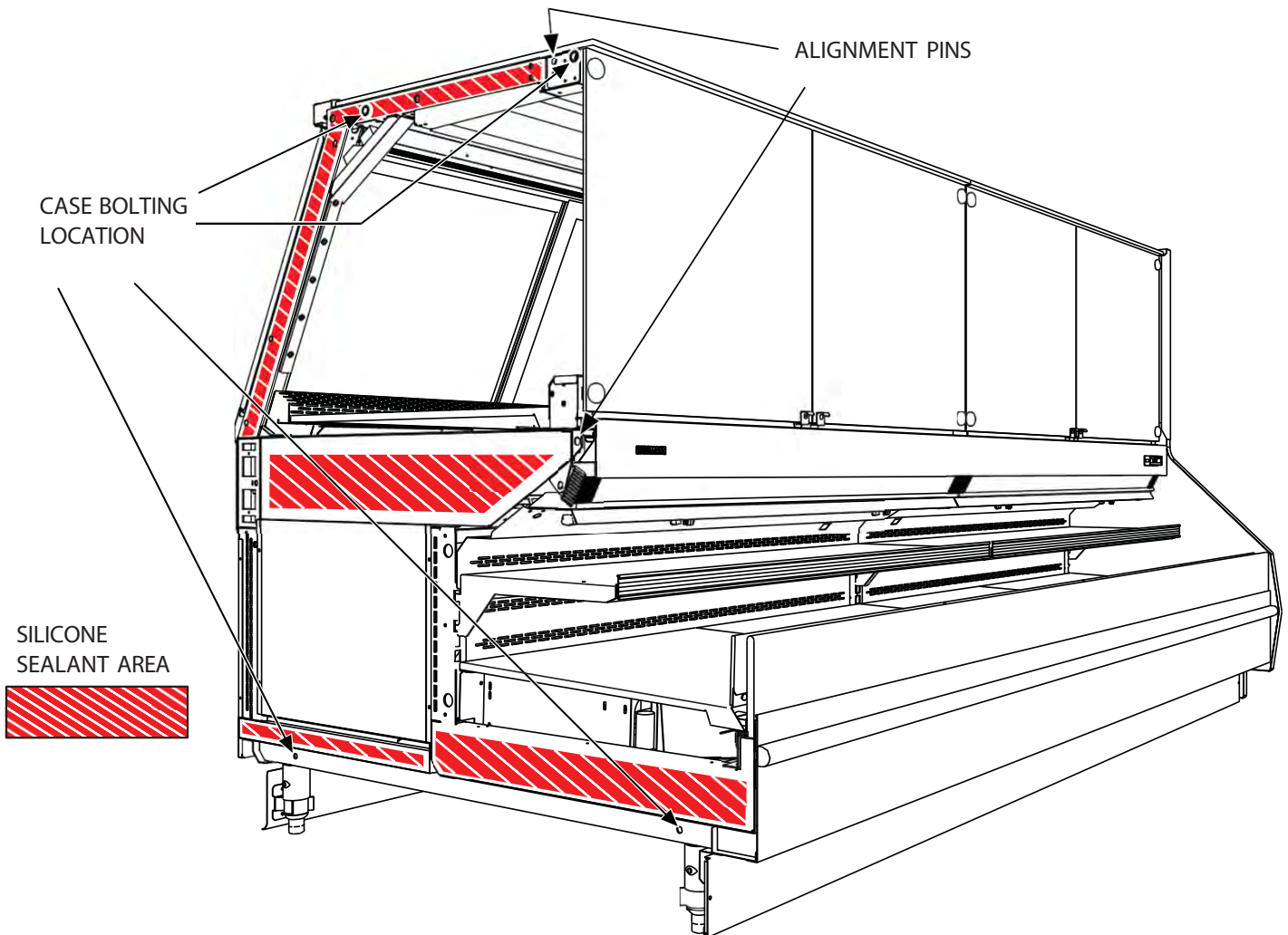
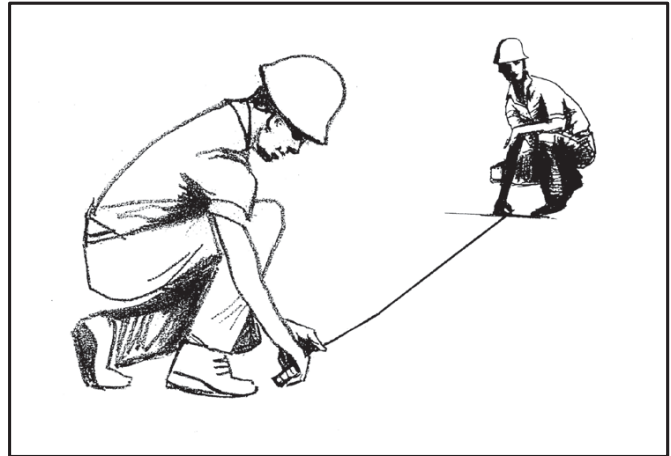

Installation (cont'd)

Setting

STEP 1. Using case blueprints, measure off and mark on the floor the exact dimensions of where the cases will sit. Snap chalk line for front and back positions of base rail or pedestal. Mark the location of each joint front and back. Find the highest point throughout the lineup. **FLOORS ARE NORMALLY NOT LEVEL!** Determine the highest point of the floor; cases will be set off this point. All cases in the entire lineup must be brought up to the highest level of the case sitting at the highest point in the lineup.

STEP 2. Set first case over the highest part of the floor and adjust legs so that case is level.

STEP 3. Set second case within one foot (1') of the first case. Keep the supports along the length of the case and far end of case. Level case to the first using the instructions in step one.



**ATTENTION
INSTALLER**

It is the contractor's responsibility to install case(s) according to local construction and health codes.

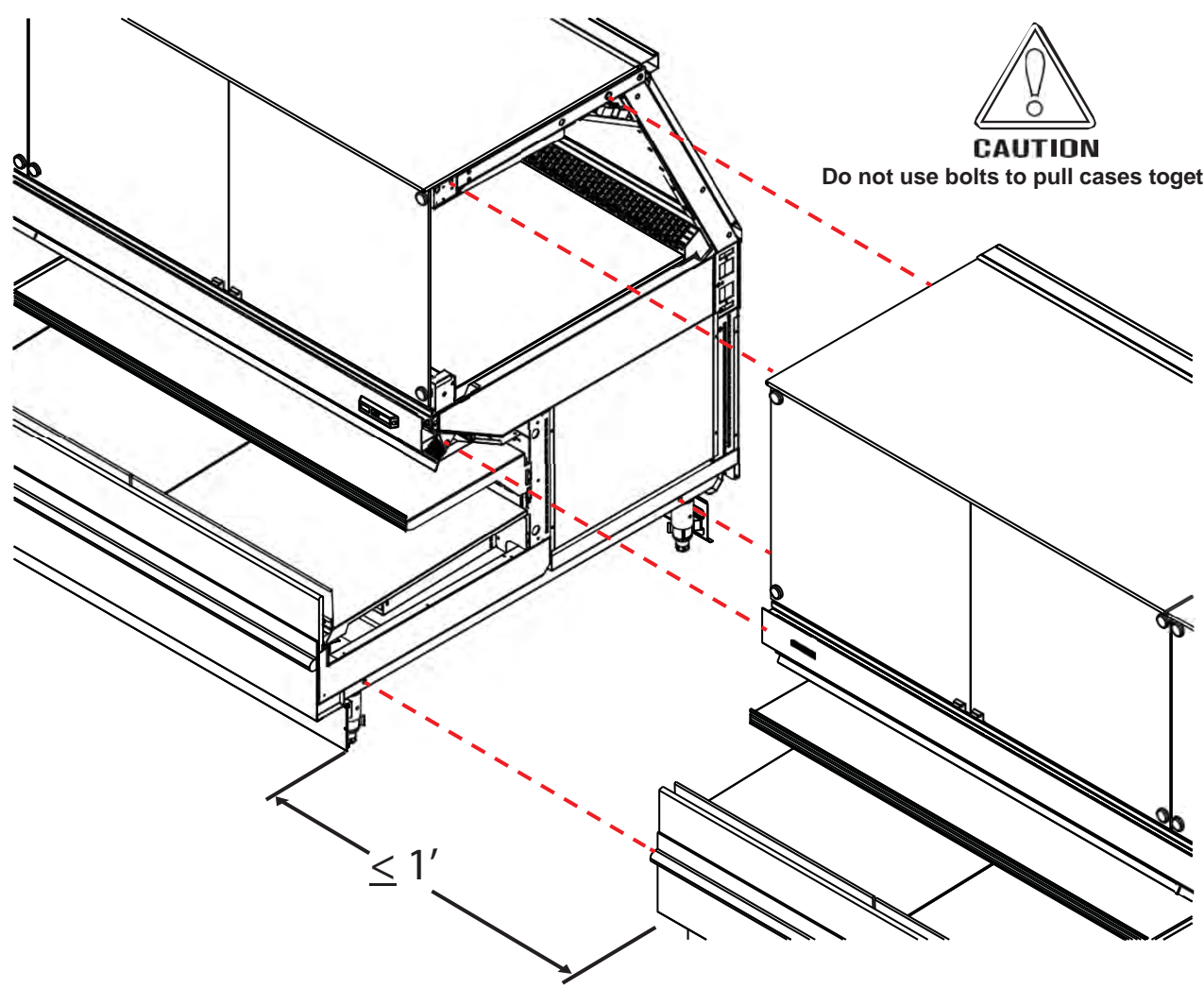

Installation (cont'd)

STEP 4. Apply liberal bead of case joint sealant (Silicone) to first case. Sealant area is shown in illustration. Apply heavy amount to cover entire shaded area. (pg10)

STEP 5. Slide second case up to first case snugly. Then level second case to the first case so glass front, bumper and top are flush.

STEP 6. To compress butyl at joint, use two Jurgenson wood clamps. Make sure case is level from front to back and side to side on inside bulkheads at joint.

STEP 7. Attach sections together.

STEP 8. Apply bead of butyl to top of bulk heads and slide on stainless steel bulkhead cap as pictured below. Also apply silicone to seam between joints.

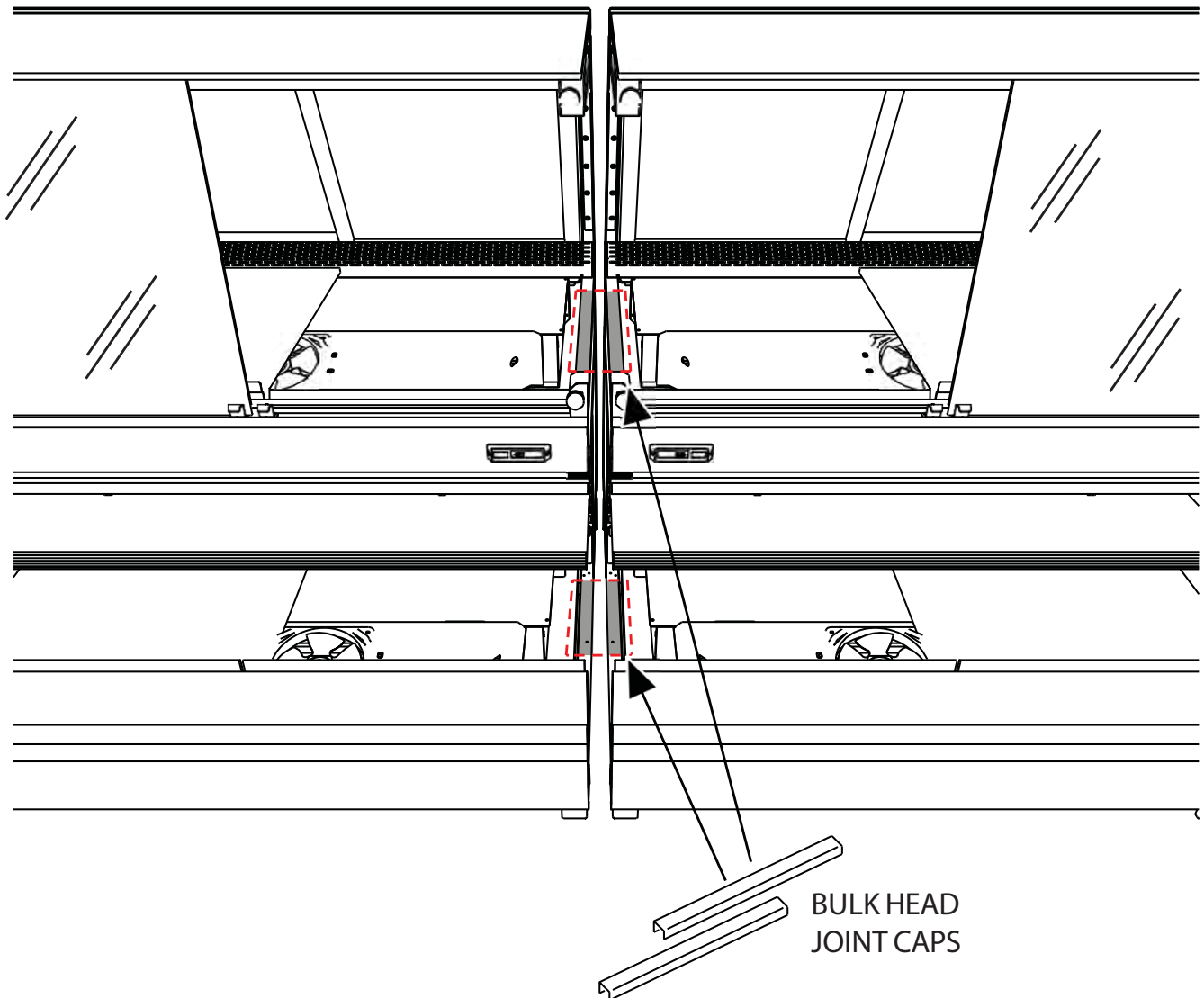

Installation (cont'd)

VR3HV Arm Adjustment

STEP 1. Ensure case is level to the ground. Check level at the bulkhead.

STEP 2. Remove access cap and cover as shown below

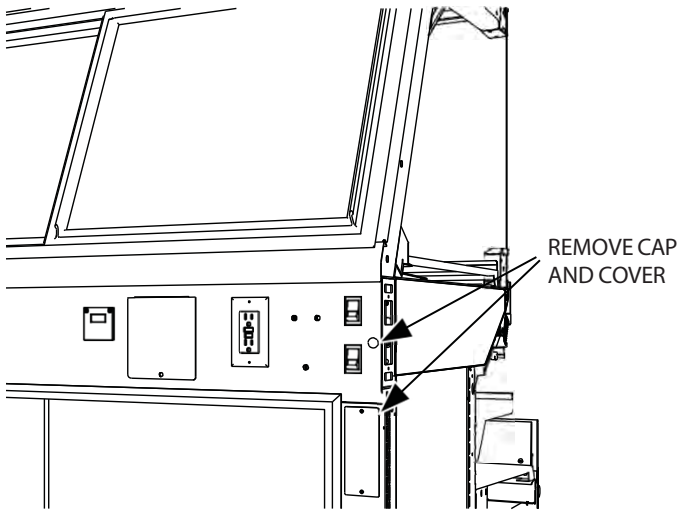

- STEP 3. Loosen lock bolt (See Detail B)
 STEP 4. Properly adjust the height of the glass requires that all hinge arms of each section be tightened or loosened evenly.
- Turning the bolt clockwise, the front arm and glass will lower.
 - Turning the bolt counter-clockwise, the arm and glass will raise.
- STEP 5. Tighten lock bolt
 STEP 6. Replace access cap and cover.

IMPORTANT! Preload the canopy crm to minimize sag from product.

IMPORTANT! ATTEMPTING TO COMPENSATE FOR POOR INSTALLATION PRACTICES BY MANIPULATING THE CANOPY HARDWARE WILL RESULT IN UNSATISFACTORY WORKMANSHIP AND POSSIBLY CAUSE HARDWARE FAILURE AND/OR INJURY.

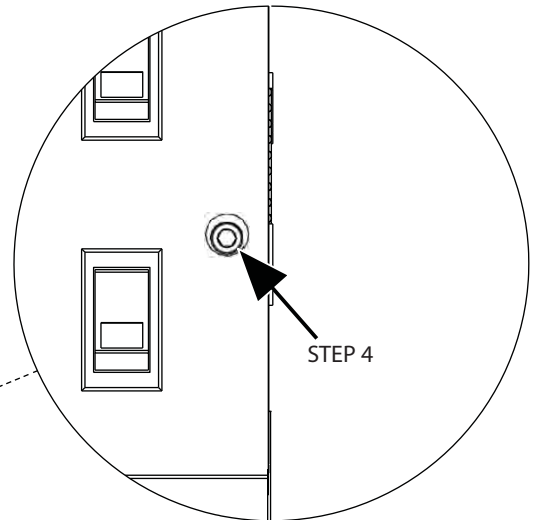

DETAIL A

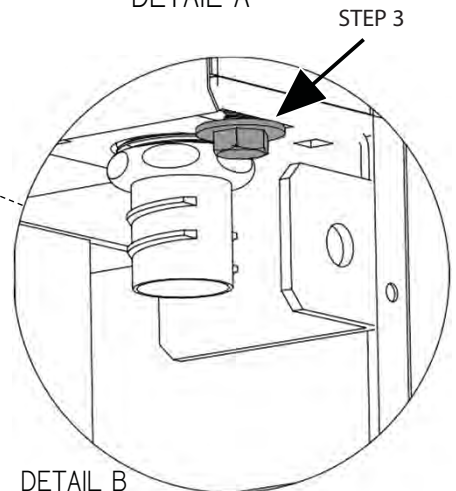

DETAIL B
(BASE CHANNEL NOT SHOWN)

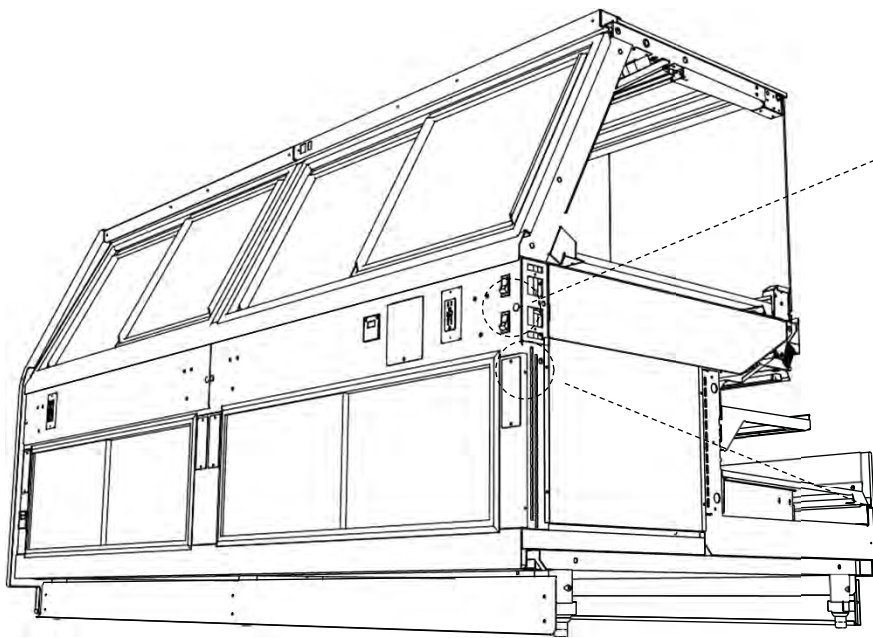

Installation (cont'd)

VR3HV Glass Adjustment

Follow these steps accordingly to properly and safely adjust the position of the front glass.

BEFORE ADJUSTING GLASS

- SET, LEVEL, AND BOLT TOGETHER ALL CASES.
- DOUBLE CHECK LEVELING FOR ALL CASES.
- DO NOT MOVE LINEUP DURING ADJUSTMENT.

Glass must be parallel to ledge when viewed from front. Glass height should be centered on "V" glass seal as demonstrated below.

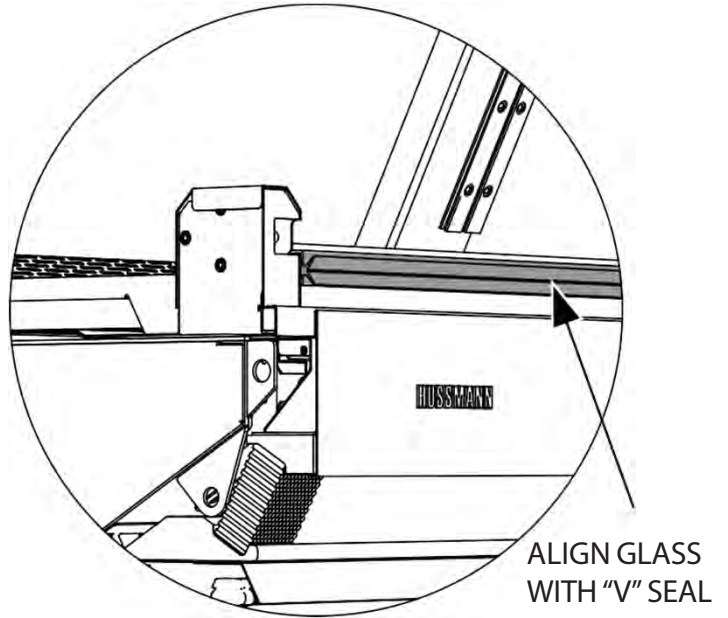

Before adjusting glass
Set, Level, and Bolt together all cases
Double check leveling for all cases
Do not move lineup during adjustment

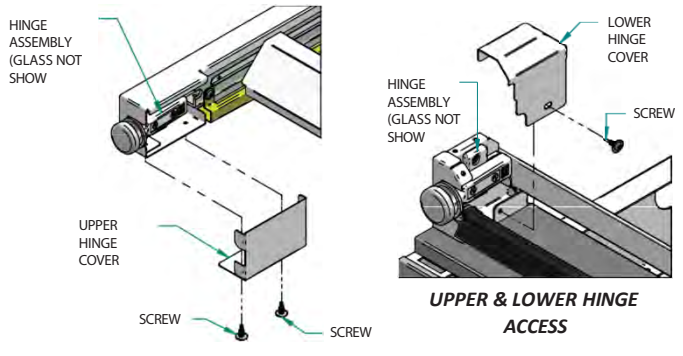

UP & DOWN

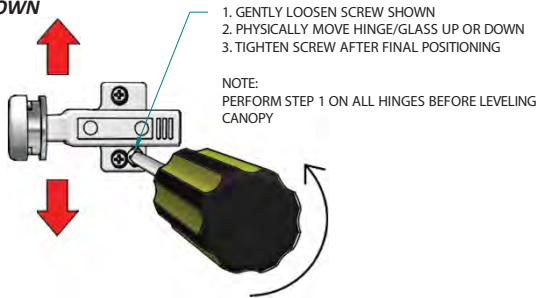

IN & OUT

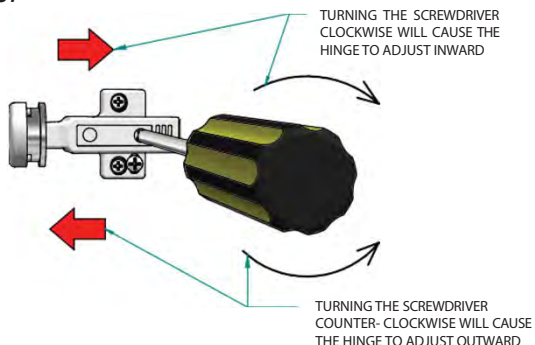

LEFT & RIGHT

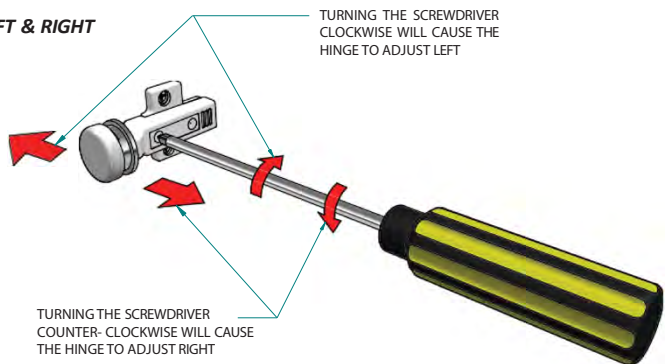

Installation (cont'd)

Front Body Panel Install

No tools will be needed to install body panels.

To begin bottom panel assembly place the front panel along in front of the case and align the base legs just underneath the lower sections of the case. Snap in spring clips to the base legs of the case.

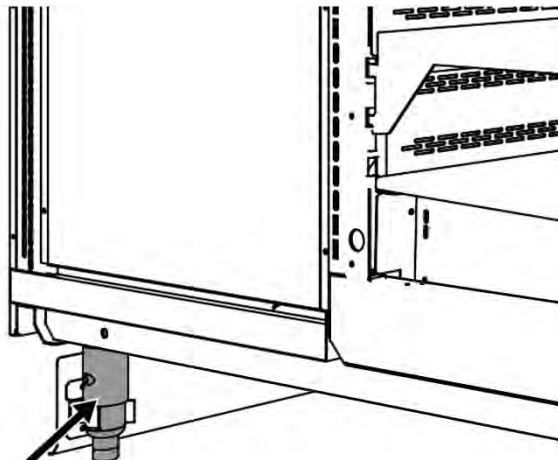
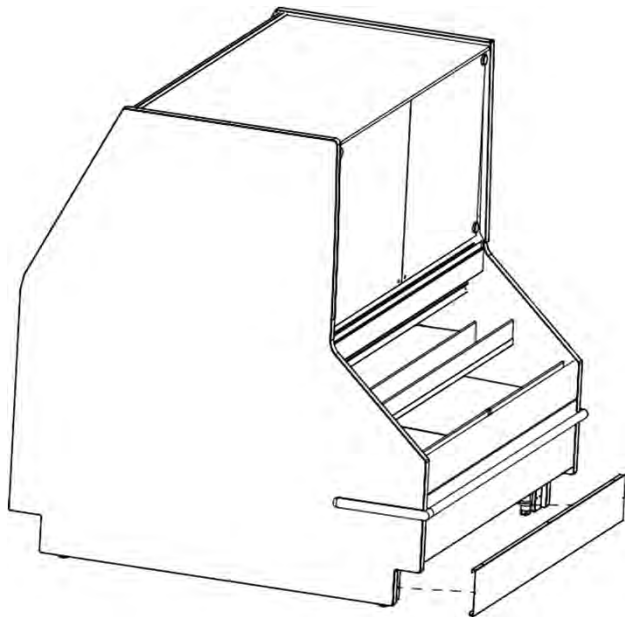

BASE LEG

Fasten Rear Body Panel Install

- (1) Align clips of rear panel to base legs of case
- (2) Secure top and bottom clips of rear panel to base legs as shown below.

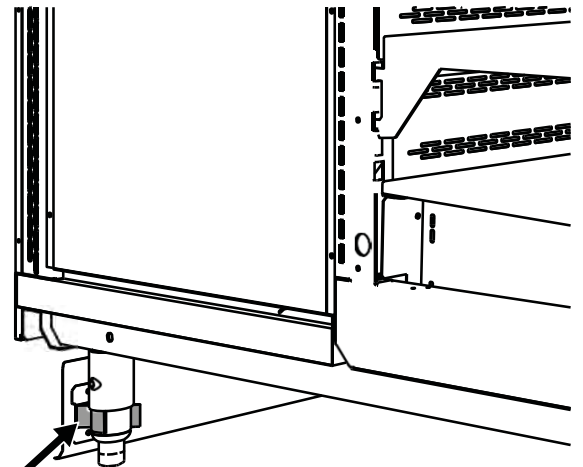
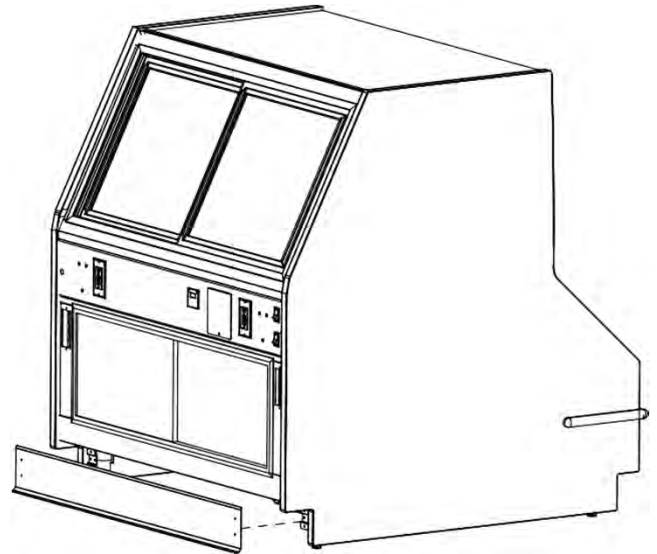

SPRING CLIP

Refrigeration

Refrigerant

The correct type of refrigerant will be stamped on each merchandiser's serial plate. **The case refrigeration piping is pressurized with a nitrogen holding charge, leak tested and factory sealed.** Before making refrigeration hookups, depress universal line valve (Shraeder Valve) to ensure that coils have maintained pressure during shipment. If in the case pressure was not maintained, contact your Hussmann Service Tech for further assistance.

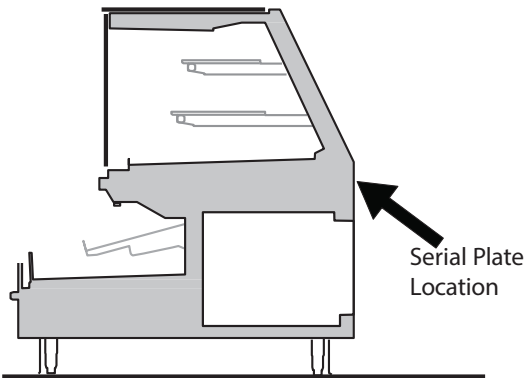

CAUTION

Refrigeration lines are under pressure. Refrigerant must be recovered before attempting to make any connections.

WARNING!
Do NOT apply thread sealer to ABS P-Trap.



Refrigerant piping

The refrigerant line connections are at the right hand end of the case (as viewed from the front) beneath the display pans. The merchandiser will beforehand ensure an earlier cut hole through the pod to exit the merchandiser for the refrigeration lines. After connections have been made, make certain to seal this outlet thoroughly if not sealed at factory already. Seal both the inside and outside. We recommend using an expanding polyurethane foam insulation.

Line Sizing

Refrigerant should be sized as shown on the refrigeration legend that is furnished for the store or according to the ASHRAE guidelines.

P-traps

P-traps must be installed at the base of all refrigerated cases. The 1 1/2" P-TRAP and threaded adapter must be installed to prevent air leakage and insect entrance into the fixture.

Oil Traps

Oil traps must be installed at the base of all suction line vertical risers on refrigerated cases.

ATTENTION INSTALLER

It is the contractor's responsibility to install case(s) according to local construction and health codes.

Refrigeration (cont'd)

Piping

The refrigerant line outlets are located under the deck pans. Insulate suction lines to prevent condensation drippage.

Refrigeration Lines

<u>Liquid</u>	<u>Suction</u>
3/8" O.D.	5/8" O.D.

NOTE: The standard coil is piped at 5/8" (suction); however, the store tie-in may vary depending on the number of coils and the draw the case has. Depending on the case setup, the connecting point in the store may be 5/8", 7/8", or 1 1/8". Refer to the particular case you are hooking up.

Refrigerant lines should be sized as shown on the refrigeration legend furnished by the store.

Pressure drop can rob the system of capacity. To keep the pressure drop to a minimum, keep refrigerant line run as short as possible, using the minimum number of elbows. Where elbows are required, use long radius elbows only.

Control Settings

See VR3HV technical data sheet for the appropriate settings for your merchandiser. Maintain these parameters to achieve near constant product temperatures. Product temperature should be measured first thing in the morning, after having been refrigerated overnight. For all multiplexing, defrost should be time terminated. Defrost times should be as follows: OFF CYCLE - Four times daily for 30 minutes. The number of defrosts per day should never change. The duration of the defrost cycle may be adjusted to meet conditions present at your location.

Access to TX Valves and Drain Lines

Mechanical - Remove product from end of case. Remove product decks. Remove refrigeration and drain access panels (labeled). TX valve (mechanical only) and drain are located under each access panel at end of the case.

Electronic - The Electronic Expansion valve master and slave cylinder(s) are located within the electrical access panel(s).

Electronic Expansion Valve (Optional)

A wide variety of electronic expansion valves and case controllers can be utilized. Please refer to EEV and controller manufacturers information sheet. Sensors for electronic expansion valves will be installed on the coil outlet, and in the discharge air. (Some supermarkets require a 3rd sensor in the return air). Case controllers will be located in the electrical raceway or under the case.

Thermostatic Expansion Valve

Location

This device is located on the same side as the refrigeration stub. A balanced port expansion valve model is furnished as a standard equipment, unless otherwise specified by the customer

Expansion Valve Adjustment

Expansion valves must be adjusted to fully feed the evaporator. Before attempting any adjustments, make sure the evaporator is either clear or very lightly covered with frost, and that the fixture is within 10°F of its expected operating temperature.

Measuring the Operating Superheat

1. Determine the suction pressure with an accurate pressure gauge at the evaporator outlet.
2. From a refrigerant pressure temperature chart, determine the saturation temperature at the observed suction pressure.
3. Measure the temperature of the suction gas at the thermostatic remote bulb location.
4. Subtract the saturation temperature obtained in step No. 2 from the temperature measured in step No. 3.
5. The difference is superheat.
6. Set the superheat for 5°F - 7°F.

Evaporator Pressure Regulator

An Evaporator Pressure Regulator is installed in the front of the self-service section to maintain a constant discharge temperature. It is located at the front right side of the case, under the fan plenum near the TEX Valve.

Service Case Temperature Control

Temperature control in the upper section of the VR3 with the Service Option is done by means of a thermostat and suction solenoid valve. This controls both temperature and humidity.

T-STAT Location

The T-STATS are located within the electrical raceway. Refer to the wiring diagram (pg. 22-29). There are also labels on the back of the case indicating T-STAT location(s).

Refrigeration Spec Sheet



HIGH VOLUME VERTICAL GLASS DELI & BAKERY SERVICE - SELF SERVICE
HUSSMANN - VR3HV-D & B UH, SH, & +2H OPTIONS (CHMO)

REVISION DATE 02/27/20

DOE 2017 Energy Efficiency Compliant
 Attention: (3) separate energy labels will be sent for use in the United States meet or surpass the requirements of the (3) 7617 energy efficiency standard.



VR3HV-D shown

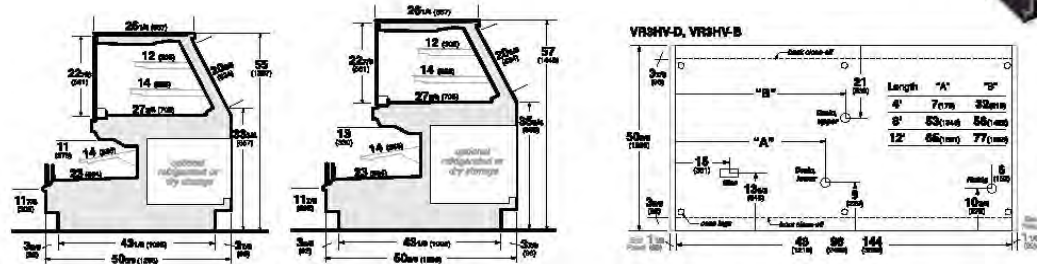

REFRIGERATION DATA:

CASE LENGTHS	CASE USAGE	CAPACITY TOP/FRONT*** (BTU/HR/FT)		TEMPERATURE (°F)			VELOCITY TOP/FRONT (FT/MIN)
		RATING CONDITION		EVAPORATOR TOP/FRONT		DISCHARGE AIR TOP/FRONT** (°F)	
		NSF 7	AHRI 1200	NSF 7	AHRI 1200	NSF 7	
4', 6', 8', 10', 12'	DELI/BAKERY	320/480	320/480	26/26	26/26	28-30/30-32	60~100/150~200
45° OS	DELI/BAKERY	1400/2000	1400/2000	26/26	26/26	28-29/34-35	50~100/150~200
REAR STORAGE	DELI/BAKERY	90	90	26	26	32-34	600~725

CASE LENGTHS	EST. REFG. CHR.G. 404A (LBS)	20° F GLYCOL 6° RISE					
		TOP		FRONT		REAR STORAGE	
		GPM	PSI	GPM	PSI	GPM	PSI
4'	1.2	0.5	1.1	0.7	1.7	0.1	0.0
6'	1.6	0.7	2.6	1.0	3.9	0.2	0.0
8'	2.1	0.9	1.1	1.4	1.8	0.2	0.3
10'	2.7	1.2	2.1	1.7	3.1	0.3	0.5
12'	3.2	1.4	2.5	2.0	3.7	0.4	0.7
45° OS	1.0	0.4	0.4	0.6	0.7	N/A	N/A

**FRONT DISCHARGE AIR MEASURED INSIDE AIR CURTAIN HONEYCOMB

***REFRIGERATION NOTES:

- 1) BTU'S DO NOT INCLUDE LIGHTS. ADD 10 BTU'S PER FOOT, PER SHELF FOR OPTIONAL LED SHELF LIGHT.
- 2) 2H OPTION; ADD 45 BTU/HR/FT FOR THE FRONT, ADD 5 BTU/HR/FT FOR THE REAR STORAGE.
- 3) 4H OPTION; ADD 80 BTU/HR/FT FOR THE FRONT, ADD 10 BTU/HR/FT FOR THE REAR STORAGE.
- 4) AHRI 1200 RATING POINT FOR ENERGY CONSUMPTION COMPARISON ONLY
- 5) USE DEW POINT FOR HIGH GLIDE REFRIGERANTS. CARE SHOULD BE TAKEN TO USE THE DEW POINT IN P/T TABLES FOR MEASURING AND ADJUSTING SUPERHEAT. ADJUST EVAPORATOR PRESSURE AS NEEDED TO MAINTAIN THE DISCHARGE AIR TEMPERATURE SHOWN.
- 6) RATING CONDITION IS NSF TYPE I, 75 °F/55% RH

REFRIGERATION DATA CONTINUED:

ELEC. THERMOSTAT / AIR SENSOR SETTINGS			DEFROST TYPE	TIME (MIN)	DEFROST FREQUENCY (#/DAY)	TERM. TEMP (°F) COIL ONLY	DRIP TIME	DEFROST WATER (LBS/DAY/FT)
USAGE	CUT IN (°F)	CUT OUT (°F)						
TOP	31	28	OFF TIME	30	4	45	N/A	4.2
FRONT	31	28						
REAR STORAGE	37	36						

END PANEL WIDTH KEY		
# OF END PNL'S	END PNL WIDTH (IN.)	TOTAL ADDED LENGTH (IN.)
1	1.125	1.125
2	1.125	2.25

ELECTRICAL DATA:

STANDARD FANS, HEATERS, LED LIGHTS (115 VOLT)

CASE LENGTH	TOTAL EVAPORATOR FANS TOP AND FRONT				CANOPY LIGHTS LED TOP AND FRONT		OPTIONAL LED SHELF LIGHTS TOP AND FRONT		MAX. LED LOAD (W/ALL OPTIONS)		ANTI-SWEAT HEATERS		CONVENIENCE OUTLETS (OPTIONAL)			
	# OF EVAP FANS	BLADE DIA. (IN.)	BLADE PITCH TOP/FRONT (°)	AMPS	WATTS	AMPS	WATTS	AMPS	WATTS	AMPS	WATTS	AMPS	WATTS	# OUTLETS	VOLTS	AMPS
4'	1/2	6.70	20/15	0.4	24	0.2	21	0.3	31	0.4	51	1.3	150	1	115	15
6'	2/4	6.70	20/15	0.7	48	0.3	31	0.4	46	0.7	77	2.0	225	1	115	15
8'	2/4	6.70	20/15	0.7	48	0.4	41	0.5	62	0.9	103	2.6	300	1	115	15
10'	3/6	6.70	20/15	1.1	72	0.6	72	0.7	78	1.3	150	2.2	250	1	115	15
12'	3/6	6.70	20/15	1.1	72	0.5	62	0.8	93	1.3	154	3.9	450	2	115	30
45° OS	1/1	6.70	N/A/20	0.2	13	0.1	8	N/A	N/A	N/A	N/A	0.7	82	N/A	N/A	N/A

OPTIONAL HIGH OUTPUT LED LIGHTS (115 VOLT)

CASE LENGTH	CANOPY LIGHTS H.O. LED TOP AND FRONT		OPTIONAL SHELF TOP AND FRONT		MAX. H.O. LED LOAD	
	AMPS	WATTS	AMPS	WATTS	AMPS	WATTS
4'	0.3	30	0.5	56	0.8	86
6'	0.5	52	0.8	93	1.3	145
8'	0.5	61	1.0	112	1.5	173
10'	N/A	N/A	N/A	N/A	N/A	N/A
12'	0.8	91	1.5	168	2.3	259
45° OS	N/A	N/A	N/A	N/A	N/A	N/A

REFRIGERATED REAR STORAGE (OPTIONAL) EVAP. FANS

CASE LENGTH	# OF EVAP FANS	BLADE DIA. (IN.)	BLADE PITCH (°)	AMPS	WATTS
4'	1	6.7	30	0.3	8.8
6'	1	6.7	30	0.3	8.8
8'	1	6.7	30	0.3	8.8
10'	1	6.7	30	0.3	8.8
12'	1	6.7	30	0.3	8.8
45° OS	N/A	N/A	N/A	N/A	N/A

Electrical

Merchandiser Electrical Data

Technical data sheets are shipped with this manual. The data sheets provide merchandiser electrical data. Refer to the technical data sheets and merchandiser serial plate for electrical information.

Electrical Connections

All wiring must be in compliance with NEC and local codes. All electrical connections including both supply circuits are to be made in the electrical J-Box.

ALWAYS CHECK THE SERIAL PLATE FOR COMPONENT AMPERES

Field Wiring

Field wiring must be sized for component amperes stamped on the serial plate (refer to pg 16 for location). Actual ampere draw may be less than specified.

Identification of Wiring

Leads for all electrical circuits are identified by colored plastic bands. These bands correspond to the color code sticker (shown below) located inside the merchandiser's wireway cover.

WARNING

--LOCK OUT/TAG OUT--

To avoid serious injury or death from electrical shock, always disconnect the electrical power at the main disconnect when servicing or replacing any electrical component. This includes, but is not limited to, such items as doors, lights, fans, heaters, and thermostats.

WIRING COLOR CODE

Leads for all electrical circuits are identified by a colored plastic band: neutral wire for each circuit has either white insulation or a white plastic sleeve in addition to the color band.

- | | |
|--|--|
| Pink.....Refrig, Thermostat Low Temp | Orange OR |
| Light Blue..Refrig, Thermostat Norm Temp | Tan.....Lights |
| Dark Blue..Defrost Term, Thermostat | Maroon..... Receptacles |
| Purple.....Condensate Heaters | Yellow..... Defrost Heaters 120V |
| Brown.....Fan Motors | Red.....Defrost Heaters 208V |
| Green*.....Ground | *Either Colored Sleeve or Colored Insulation |

ELECTRICIAN NOTE: Use proper conductor wire only.
MERCHANDISER MUST BE GROUNDED

These are marker colors, wire may vary.

Electrical Cont'd

Remove Rear Raceway

The merchandisers electrical access is located at the rear of the case. Fasteners must be removed in order to gain access. See illustration below.

Remove rear raceway from rear of case.

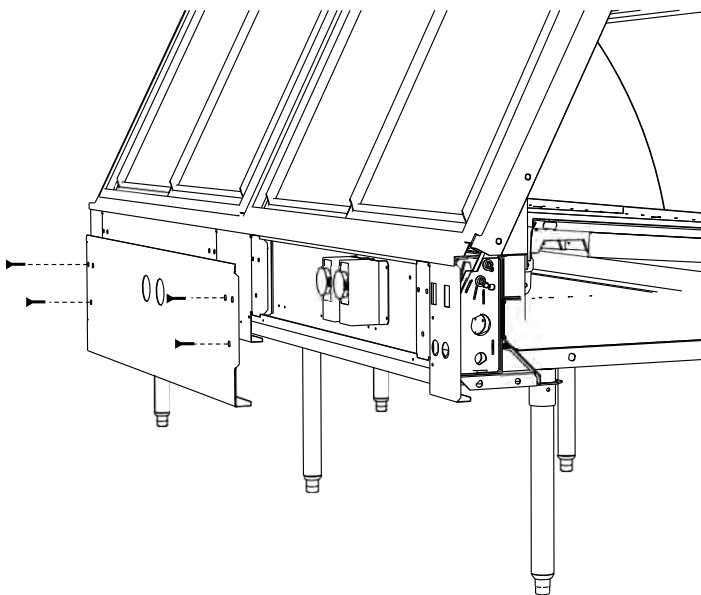

Electrical Conduit (Electrical Box)

The merchandisers electrical conduit can be found inside the compartment at the rear. Removing the raceway will gain access to the electrical components inside the J-Box allowing any maintenance necessary.

Electrical Conduit

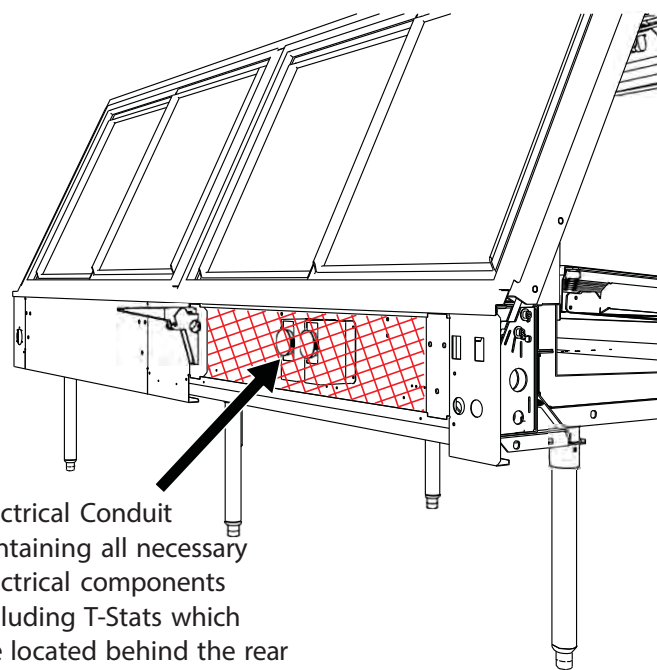

Electrical Conduit containing all necessary electrical components including T-Stats which are located behind the rear raceway cover of the merchandiser.

Wiring Diagrams Index

VR3HV-D-R	VR3HV-D-4R	4'	3014847
	VR3HV-D-6R	6'	3014848
	VR3HV-D-8R	8'	3014849
	VR3HV-D-10-2H-RSS-R	10'	3092332
	VR3HV-D-12R	12'	3014850
	VR3HV-D-45O-SH-NS-R		3068164

REV	EN	DATE	REVISION DESCRIPTION	REV BY	CHK BY	APP BY
A	ECN-CAP-0003964	2016/09/12	RELEASED TO PRODUCTION	CB	CB	CB
B	ECN-CAP-0005978	2017/01/10	REVISED REAR STORAGE COIL	CB	CB	CB
C	ECN-CAP-0006209	2017/01/24	REVISED REAR STORAGE T-STAT	CB	CB	CB
E	ECN-COD-0015275	2022/02/15	NEW LIGHTS	CB	CB	CB
F	ECN-COD-0018714	2023/09/23	CHANGED FANS & LIGHTS	CB	CB	CB

CIRCUIT #1	LOADING
120V	
150V	
175V	
200V	

CIRCUIT #2	LOADING
120V	
150V	
175V	
200V	

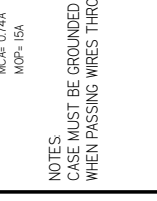
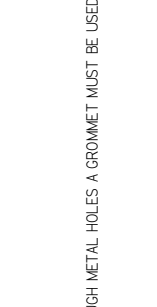
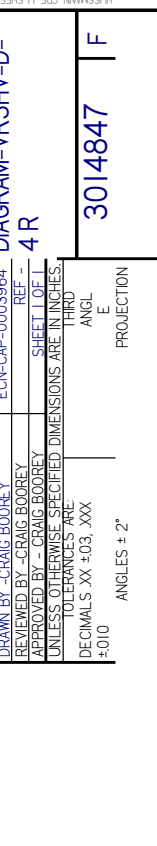
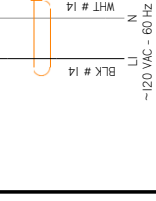
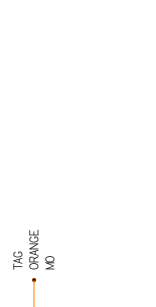
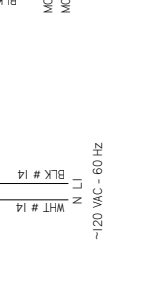
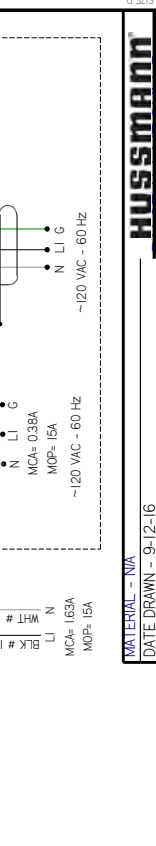
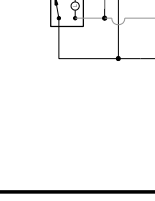
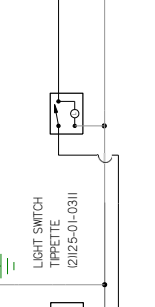
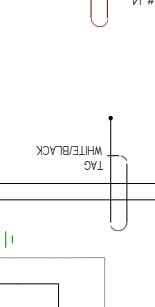
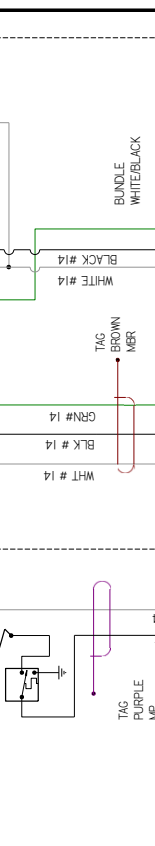
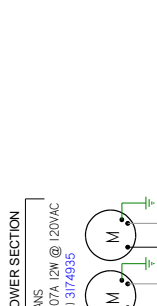
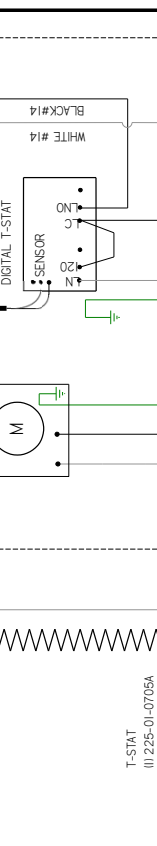
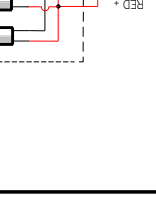
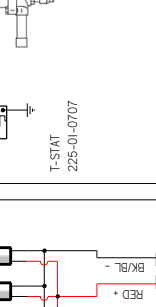
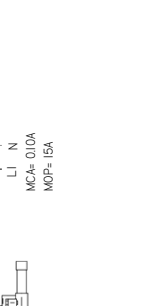
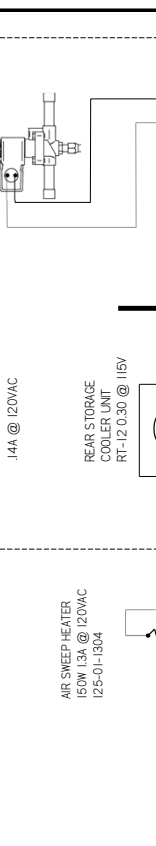
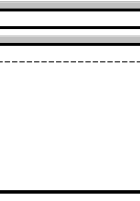
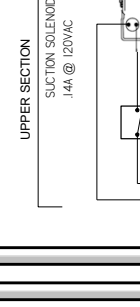
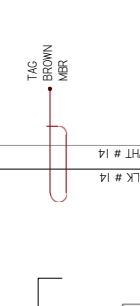
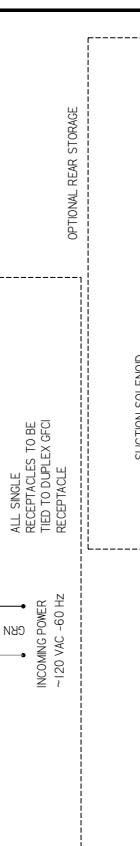
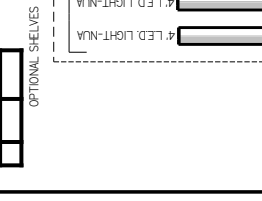
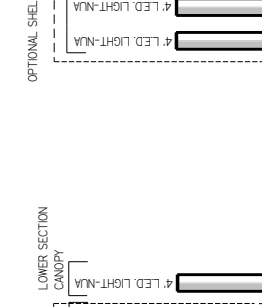
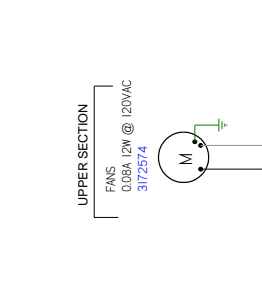
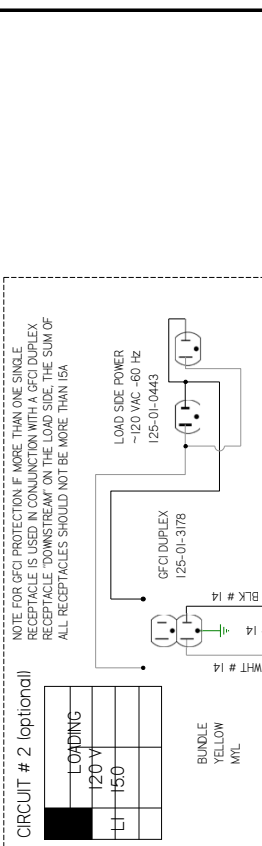

MATERIAL - N/A
DATE DRAWN - 9-12-16
DRAWN BY - CRAIG BOOREY
REVIEWED BY - CRAIG BOOREY
APPROVED BY - CRAIG BOOREY
UNLESS OTHERWISE SPECIFIED DIMENSIONS ARE IN INCHES
TOLERANCES ARE:
DECIMALS .XX +03 .XXX
+0.0
ANGLES ± 2°

HUSSMANN
DIAGRAM=VR3HV-D-
4 R
REF -
SHEET 1 OF 1
THIRD
ANG E
PROJECTION

3014847 | F

NOTES:
CASE MUST BE GROUNDED
WHEN PASSING WIRES THROUGH METAL HOLES A GROMMET MUST BE USED

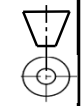

REVISION HISTORY			
REV	ECN	DATE	REVISION DESCRIPTION
B	ECN-COD-00162765	2-16-22	NEW LIGHTS
C	ECN-COD-0016714	10-23-23	CHANGED FANS & LIGHTS

CIRCUIT #1 LOADING	
120V	
150	

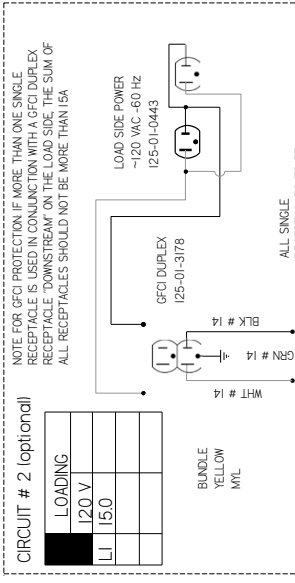

CIRCUIT #2 Optional	
120V	
150	

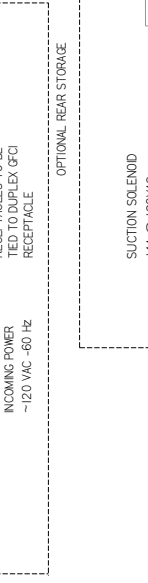

CIRCUIT #3	
120V	
150	

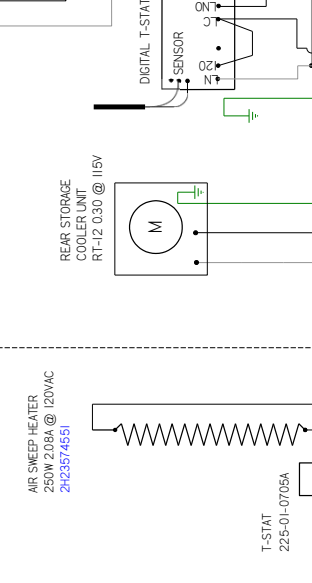

CIRCUIT #4	
120V	
150	

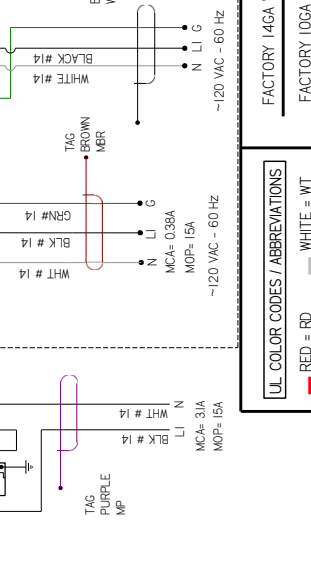

CIRCUIT #5	
120V	
150	

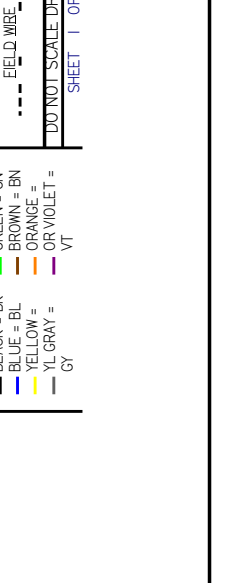

CIRCUIT #1 LOADING	
120V	
150	

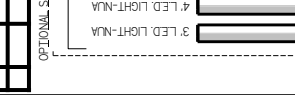

CIRCUIT #2	
120V	
150	

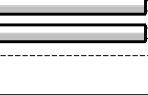

CIRCUIT #3	
120V	
150	



CIRCUIT #4	
120V	
150	



CIRCUIT #5	
120V	
150	



CIRCUIT #6	
120V	
150	

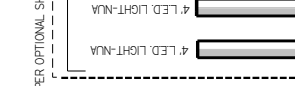

CIRCUIT #7	
120V	
150	

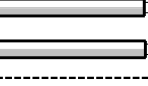

CIRCUIT #8	
120V	
150	



CIRCUIT #9	
120V	
150	



CIRCUIT #10	
120V	
150	



CIRCUIT #11	
120V	
150	

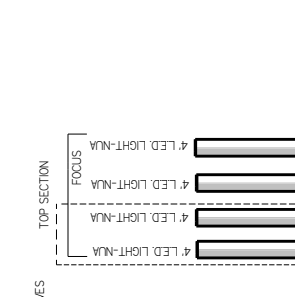

CIRCUIT #12	
120V	
150	

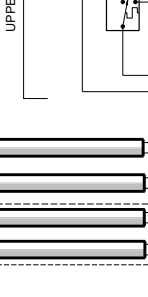

CIRCUIT #13	
120V	
150	

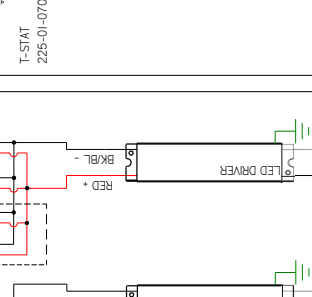

CIRCUIT #14	
120V	
150	

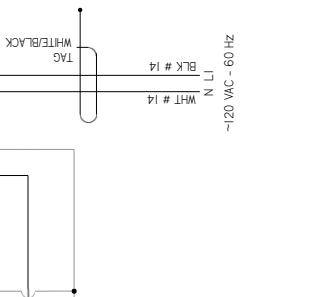

CIRCUIT #15	
120V	
150	



CIRCUIT #16	
120V	
150	



CIRCUIT #17	
120V	
150	

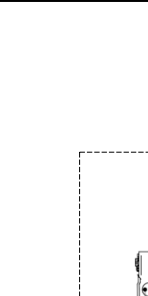

CIRCUIT #18	
120V	
150	

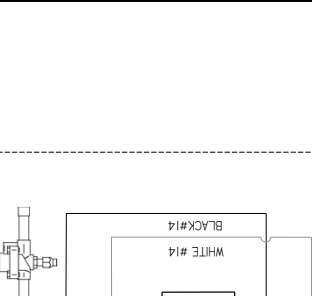

CIRCUIT #19	
120V	
150	

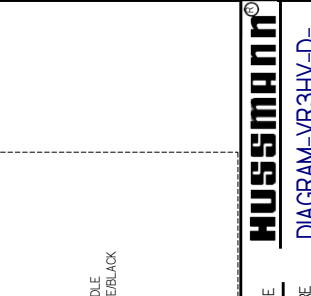

CIRCUIT #20	
120V	
150	

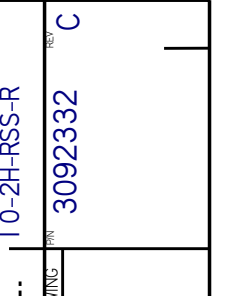

CIRCUIT #21	
120V	
150	



CIRCUIT #22	
120V	
150	

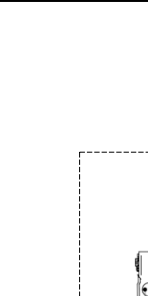

CIRCUIT #23	
120V	
150	

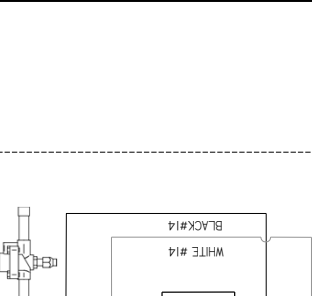

CIRCUIT #24	
120V	
150	

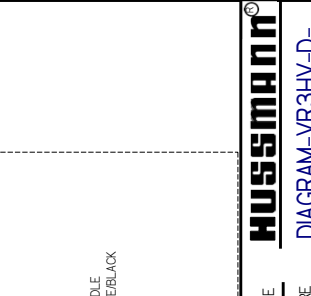

CIRCUIT #25	
120V	
150	

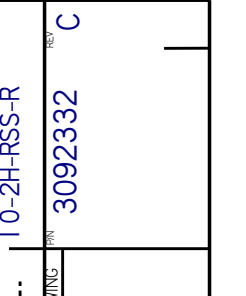

CIRCUIT #26	
120V	
150	



CIRCUIT #27	
120V	
150	

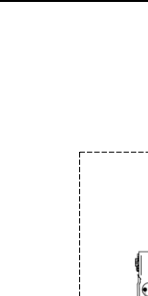

CIRCUIT #28	
120V	
150	

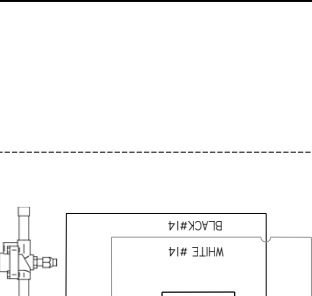

CIRCUIT #29	
120V	
150	

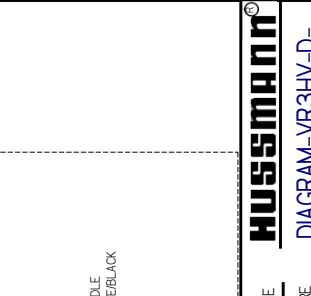

CIRCUIT #30	
120V	
150	

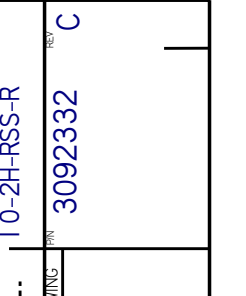

CIRCUIT #31	
120V	
150	



CIRCUIT #32	
120V	
150	

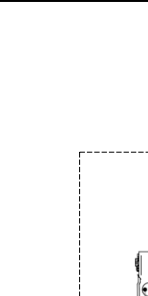

CIRCUIT #33	
120V	
150	

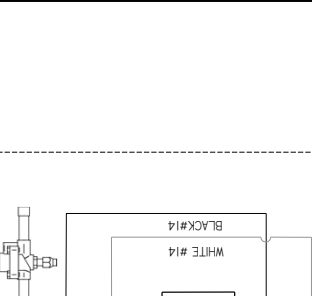

CIRCUIT #34	
120V	
150	

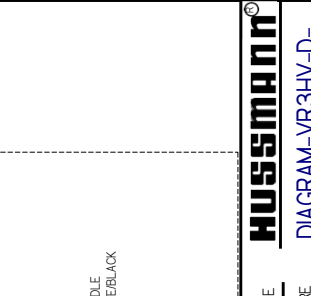

CIRCUIT #35	
120V	
150	

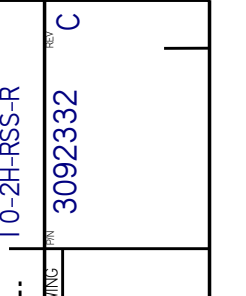

CIRCUIT #36	
120V	
150	



CIRCUIT #37	
120V	
150	

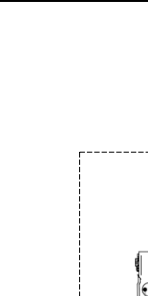

CIRCUIT #38	
120V	
150	

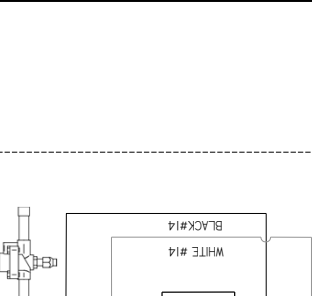

CIRCUIT #39	
120V	
150	

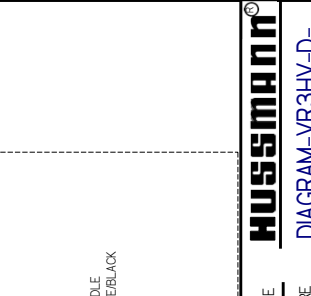

CIRCUIT #40	
120V	
150	

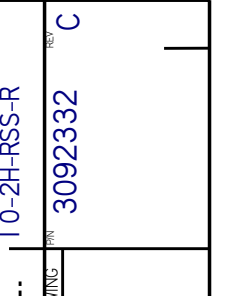

CIRCUIT #41	
120V	
150	



CIRCUIT #42	
120V	
150	

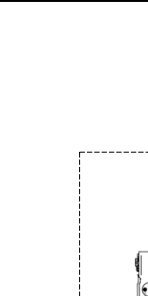

CIRCUIT #43	
120V	
150	

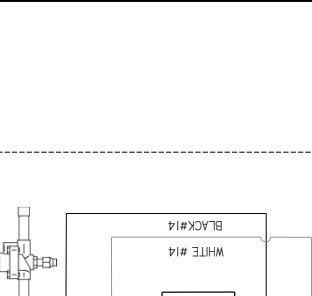

CIRCUIT #44	
120V	
150	

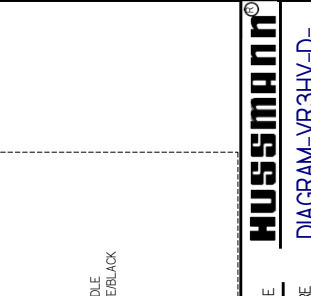

CIRCUIT #45	
120V	
150	

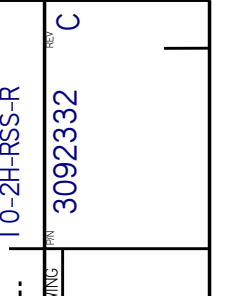

CIRCUIT #1
LOADING

120V			
150			

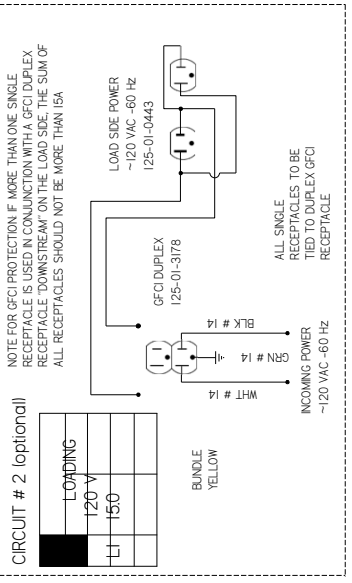
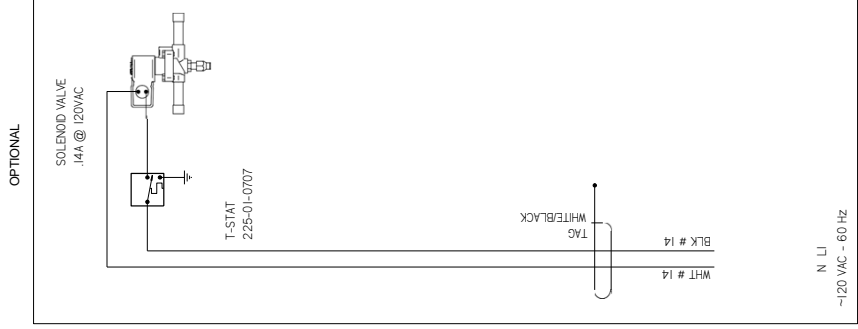
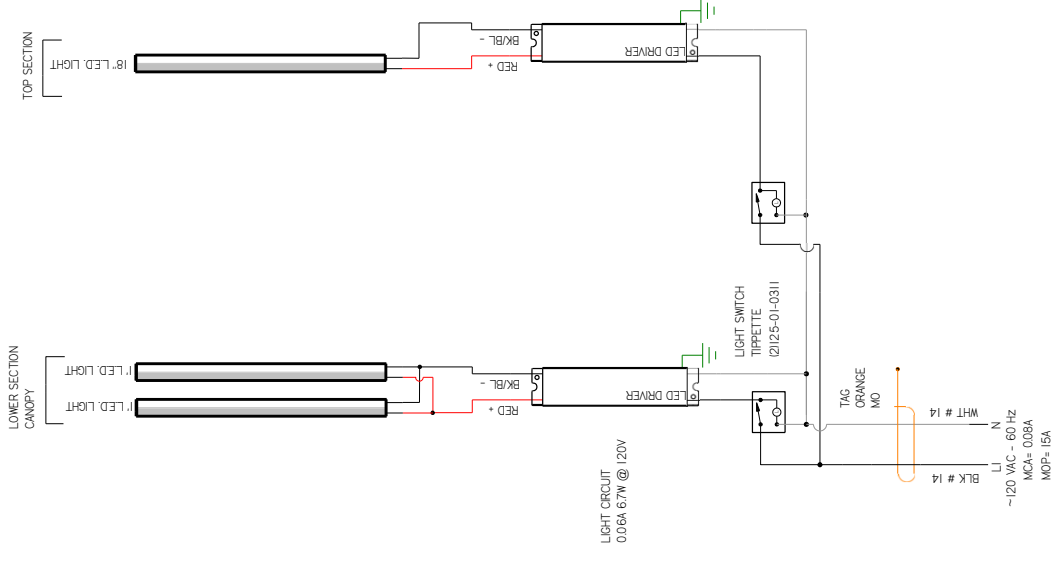

AP SWEEP HEATER
78W 0.65A @ 120VAC
125-01-3035

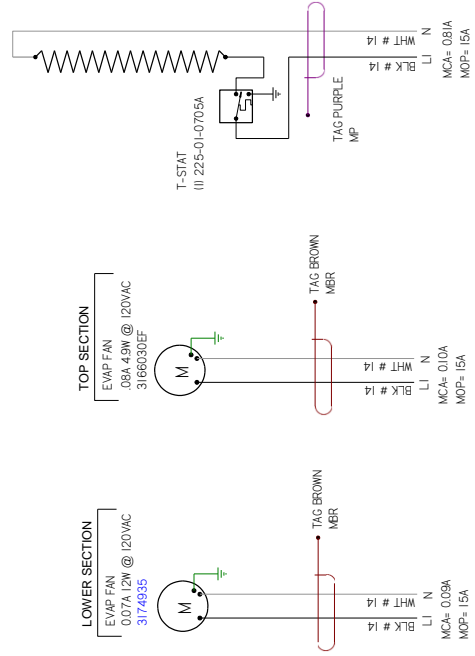

REV	EN	DATE	REVISION DESCRIPTION	REV BY	CHKD BY	APPR BY
A	ECN-CAP-0013270	2018/07/06	RELEASED TO PRODUCTION	CB	CB	CB
B	ECN-CAP-0017675	2018/07/10	REVISED TOP SECTION	CB	CB	CB
C	ECN-COD-0016637	2022/10/17	CHANGED EVAP FAN MOTOR	CB	CB	CB
D	ECN-COD-0018714	2023/10/23	CHANGED FRONT FAN	CB	CB	CB

HUSSMANN
DIAGRAM=VR3HV-D-
4-50-SH-NS-R

MATERIAL - N/A

DATE DRAWN - 7-6-18

DRAWN BY - CRAIG BOOREY

REVIEWED BY - CRAIG BOOREY

APPROVED BY - CRAIG BOOREY

UNLESS OTHERWISE SPECIFIED DIMENSIONS ARE IN INCHES

DECIMALS .XX ±0.3 .XXX ±0.10

ANGLES ± 2°

PROJECTION

3068164 | D



User Information

Start Up

See the merchandisers Data Sheet Set for refrigerant settings and defrost requirements. Bring merchandisers down to the operating temperatures listed on the Data Sheet.

⚠ WARNING

--LOCK OUT/TAG OUT--

To avoid serious injury or death from electrical shock, always disconnect the electrical power at the main disconnect when servicing or replacing any electrical component. This includes, but is not limited to, such items as doors, lights, fans, heaters, and thermostats.

Load Limit

Each Merchandiser has a load limit. Shelf life of perishables will shorten if load limit is violated.

AT NO TIME SHOULD THE MERCHANDISER BE STOCKED BEYOND THE LOAD LIMITS INDICATED.

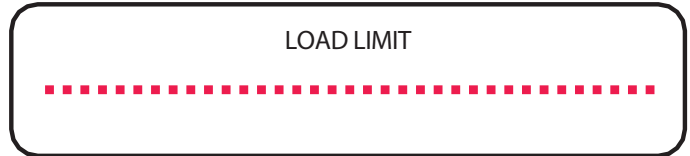

Load Limit Line

DO NOT LOAD PAST THE FOLLOWING LOAD LIMIT LINES.

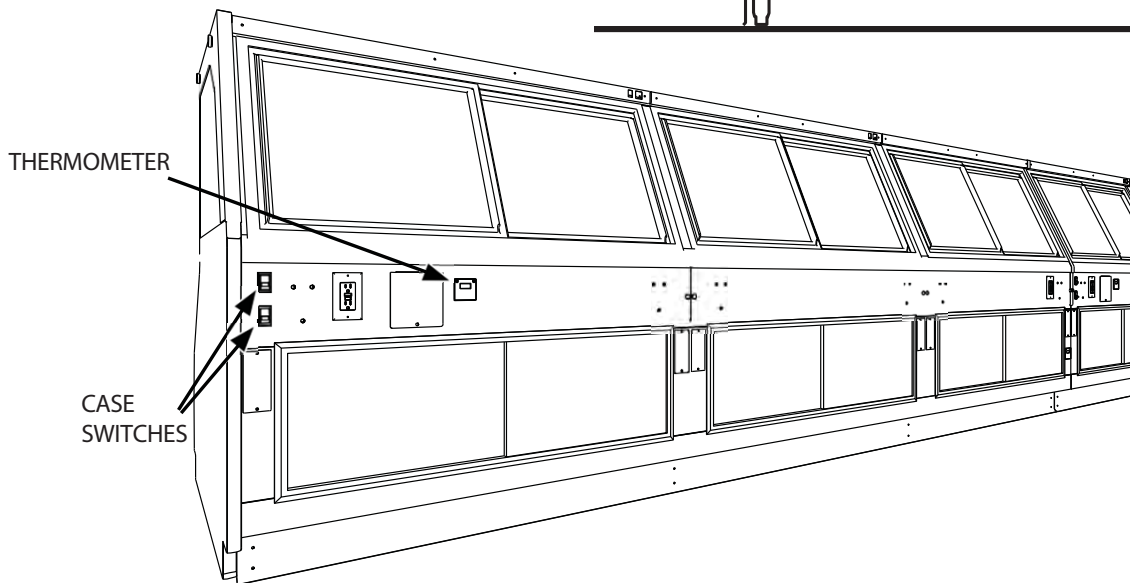
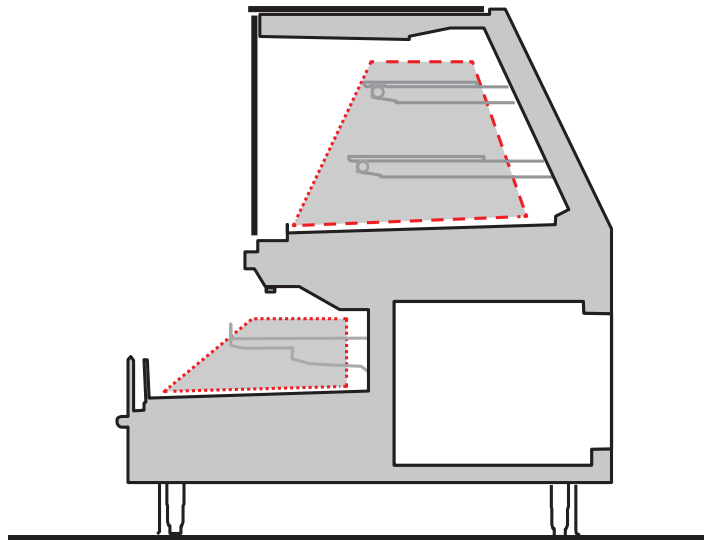

Maintenance

Case Cleaning

Long life and satisfactory performance of any equipment are dependent upon the care it receives. To insure long life, proper sanitation and minimum maintenance costs, the merchandiser should be thoroughly cleaned, all debris removed and interiors washed down, weekly.



TO PREVENT INJURY ALWAYS SHUT OFF POWER DURING CLEANING PROCESS.

Exterior Surfaces

The exterior surfaces must be cleaned with a mild detergent without chloride and warm water to protect and maintain their attractive finish. **NEVER USE ABRASIVE CLEANSERS OR SCOURING PADS.**

Cleaning Bumpers

Clean bumpers with household spray cleaners.

Cleaning Under Merchandiser

Remove lower body panels. Use a vacuum with a long wand attachment to remove accumulated dust and debris from under the merchandiser.

Cleaning Stainless Steel Surfaces

Use non abrasive cleaning materials, and always polish with the grain of the steel. Use warm water or add a mild detergent to the water and apply with a cloth. Always wipe dry after wetting.

Use non-chlorine containing cleaners such as window cleaners and mild detergents. Do not use cleaners containing salts as this may cause pitting and rusting of the stainless steel finish. Do not use bleach.

Clean frequently to avoid build-up of hard, stubborn stains. A stainless steel cleaning solution may be used periodically to minimize scratching and remove stains.

Rinse and wipe dry immediately after cleaning. Never use hydrochloric acid (muriatic acid) on stainless steel.

Interior Surfaces

The interior surfaces may be cleaned with most domestic detergents, ammonia based cleaners and sanitizing solutions that do not contain chloride with no harm to the surface.

Cleaning Coils

NEVER USE SHARP OBJECTS AROUND COILS. Use a soft brush or vacuum brush to clean debris from coils. Do not puncture Coils! Do not bend fins. Contact an authorized service technician if a coil is punctured, cracked, or otherwise damaged.

ICE in or on the coil indicates the refrigeration and defrost cycle is not operating properly. Contact an authorized Service Technician to determine the cause of icing and to make proper adjustments as necessary. To maintain product integrity, if not done so already, move all product to a cooler until the merchandiser has returned to normal operating temperatures.

Do Not Use:

- Abrasive cleaners and scouring pads, as these will damage the finish.
- A hose on lighted shelves or submerge lighted shelves in water.
- Solvent, oil or acidic based cleaners on any interior surfaces.
- A hose on LED Lights or any other electrical component.

Maintenance Cont'd

Do:

- Remove the product and all loose debris to avoid clogging the waste outlet.
- Store product in a refrigerated area such as a cooler during the cleaning process. Remove only as much product as can be taken to the cooler in a timely manner.
- **First turn off refrigeration, then disconnect electrical power to merchandiser.**
- Thoroughly clean all surfaces with soap and hot water. Do not use steam or high pressure water hoses to wash the interior. These will destroy the merchandisers' sealing causing leaks and poor performance.
- Avoid direct contact between fan motors and cleaning or rinse water.
- Rinse with hot water, but DO NOT flood. Never introduce water faster than the waste outlet can drain.
- Allow merchandiser to completely dry before resuming operation.
- LED lights are magnetized to each shelf and can be removed easily for any shelf cleaning.
- After cleaning has been completed, remember to restore power back to merchandiser.



WARNING

Product will be degrade and may spoil if allowed to sit in non-refrigerated area.

Troubleshooting

Problem	Possible Cause	Possible Solution
Case temperature is too warm.	Ambient conditions may be affecting the case operation.	Check case position in store. Is the case located near an open door, window, electric fan or air conditioning vent that may cause air currents? Case must be located minimum 15 Ft away from doors or windows. Cases are designed to operate at 55% Relative humidity and a temperature of 75°F.
	Discharge air temp is out of spec.	Check evaporator fan operation. Check electrical connections and input voltage.
		Fans are installed backwards. Check airflow direction.
		Fan blades are installed incorrectly. Make sure fan blades have correct pitch and are per specification.
		Check to see that fan plenum is installed correctly. It should not have any gaps.
		Check suction pressure and insure that it meets factory specifications.
	Case is in defrost.	Check defrost settings. See Technical Specifications section.
	Product load may be over its limits blocking airflow.	Redistribute product so it does not exceed load level. There is a sticker on the inside of the case indicating what the maximum load line is.
	Coil is freezing over.	Return air is blocked, make sure debris is not blocking the intake section.
Coil close-offs are not installed. Inspect coil to make sure these parts are on the case.		
Condensing coil or evaporator coil is clogged or dirty.	Clean coil.	
Case temperature is too cold.	The t-stat temp is set too low.	Check settings. See Technical Specifications section.
	Ambient conditions may be affecting the case operation.	Check case position in store. Is the case located near an open door, window, electric fan or air conditioning vent that may cause air currents? Case must be located minimum 15 Ft away from doors or windows. Cases are designed to operate at 55% Relative humidity and a temperature of 75°F.
Condensation on glass.	Ambient conditions may be affecting the case operation.	Check case position in store. Is the case located near an open door, window, electric fan or air conditioning vent that may cause air currents? Case must be located minimum 15 Ft away from doors or windows. Cases are designed to operate at 55% Relative humidity and a temperature of 75°F.
	Inadequate air circulation.	Check if air sweep fans are functioning, check electrical connections.
	There is not enough heat provided in the airflow.	Check if air sweep heater is functioning, check electrical connections.
	There are glass gaps on the side of the case.	See glass adjustment section.
	Glass is not completely shut.	Close glass correctly.

Troubleshooting Cont'd

Problem	Possible Cause	Possible Solution
Water has pooled under case.	Case drain is clogged.	Clear drain.
	PVC drains under case may have a leak.	Repair as needed.
	Case tub has unsealed opening.	Seal as needed.
	If the case is in a line-up, case to case joint is missing or unsealed.	Install case to case joint and seal as needed.
	Evaporator pan is overflowing (if applicable).	Check electrical connection to evaporator pan. Check float assembly, it should move freely up and down the support stem. Clear any debris.
Case is not draining properly.	Case is not level.	Level the case.
	Drain screen is plugged.	Clean drain screen and remove any debris.
	Drain or P-trap is clogged.	Clear any debris.
Frost or ice on evaporator coil.	Evaporator fans are not functioning.	Check electrical connections.
	Defrost clock is not functioning.	Case should be serviced by a qualified service technician.
	Coil is freezing over.	Return air is blocked, make sure debris is not blocking the intake section.
Coil close-offs are not installed. Inspect coil to make sure these parts are on the case.		
Lights do not come on.	Ballast/light socket wiring.	Check electrical connections. See Electrical Section and check wiring diagram.
	Ballast needs to be replaced.	Case should be serviced by a qualified service technician. See Electrical Section.
	Lamp socket needs to be replaced.	Case should be serviced by a qualified service technician.
	Lamp needs to be replaced.	See Maintenance Section.
	Light Switch needs to be replaced.	Case should be serviced by a qualified service technician.



This warning does not mean that Hussmann products will cause cancer or reproductive harm, or is in violation of any product-safety standards or requirements. As clarified by the California State government, Proposition 65 can be considered more of a ‘right to know’ law than a pure product safety law. When used as designed, Hussmann believes that our products are not harmful. We provide the Proposition 65 warning to stay in compliance with California State law. It is your responsibility to provide accurate Proposition 65 warning labels to your customers when necessary. For more information on Proposition 65, please visit the California State government website.



HUSSMANN[®]

To obtain warranty information
or other support, contact your
Hussmann representative.
Please include the model and
serial number of the product.

Hussmann Warranty / Technical Assistance
(800) 592-2060