

**HUSSMANN®/CHINO**

Installation  
& Operation  
Manual

**TY3, TY4 ISLAND CASE**  
**(ENTYCE)**

REV. 1125

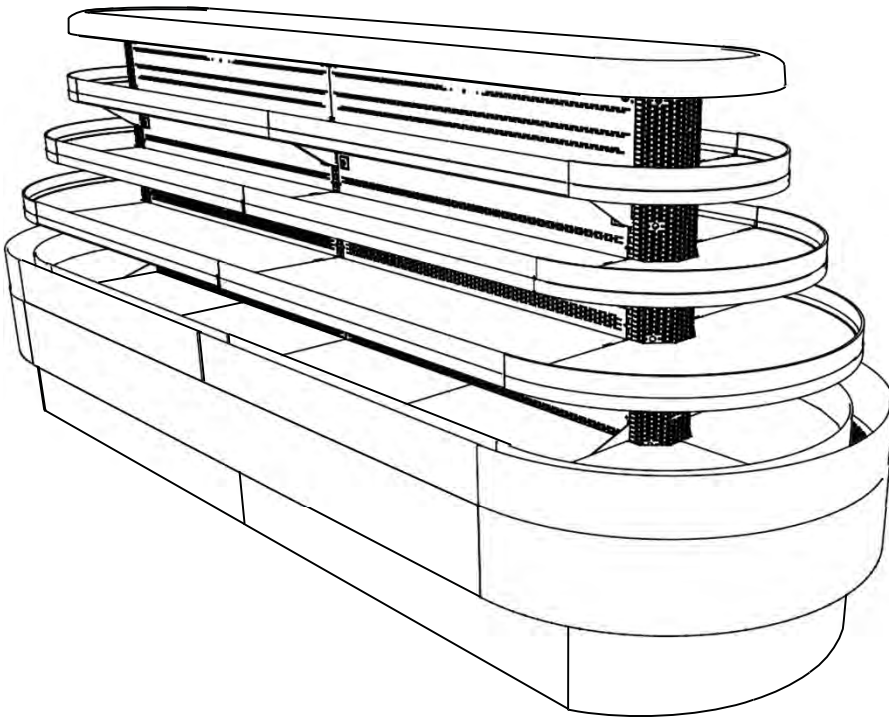

**TY3, TY4**  
**(ENTYCE)**  
**ISLAND CASE**

# Table of Contents

|                         |    |
|-------------------------|----|
| Warning                 | 4  |
| General Information     | 6  |
| Cut and Plan Views      | 7  |
| Installation            | 9  |
| Plumbing                | 11 |
| Refrigeration Piping    | 12 |
| Sump Pump Configuration | 13 |
| Specifications          | 15 |
| Electrical              | 18 |
| Wiring Diagrams Index   | 19 |
| Wiring Diagrams         | 21 |
| User Information        | 75 |
| Troubleshooting         | 76 |
| Appendix                | 78 |



# WARNING

1. Do Not Push, Pull, Adjust, or Manipulate the TY case by any glass component.
  - Doing so will result in severe damage to such components
  - Glass breakage may result in serious injury
2. Never stand on the TY Top, Deck, or any Shelves for any reason.
  - Misusing these surfaces as steps will result in damage to the case
  - Misusing these surfaces as steps may result in serious injury to the user
  - These surfaces are intended for the storage and merchandising of food products
  - Use a ladder or designed structure to work above the case (Do not lean on case)
3. DO NOT remove shelves. WARNING! will adversely impact case performance when merchandising.

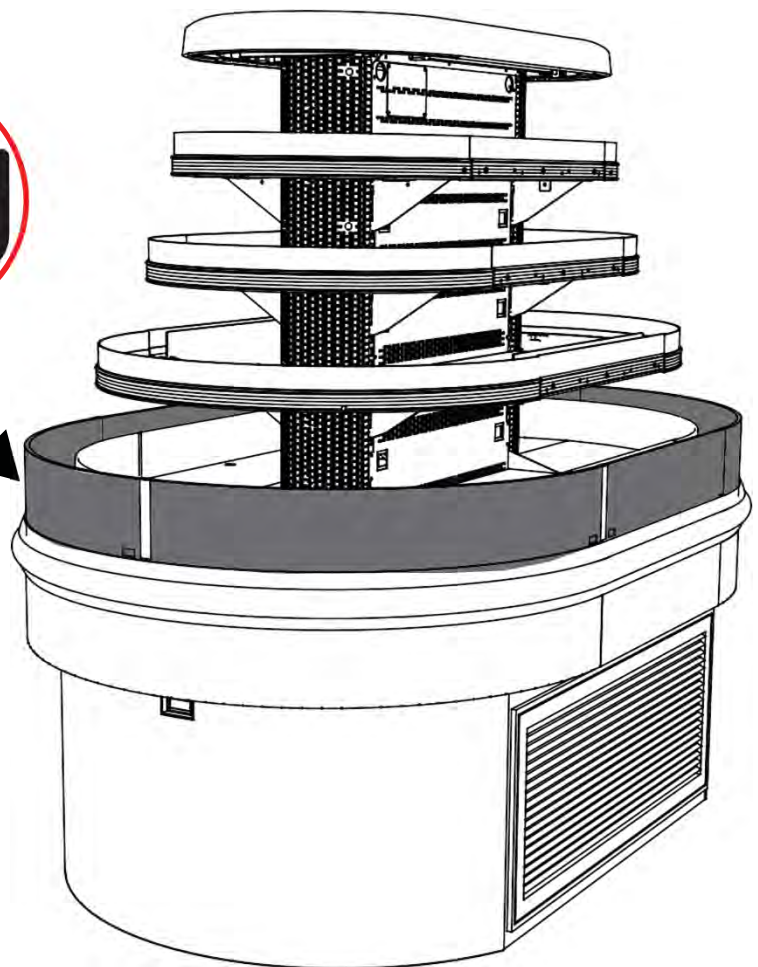
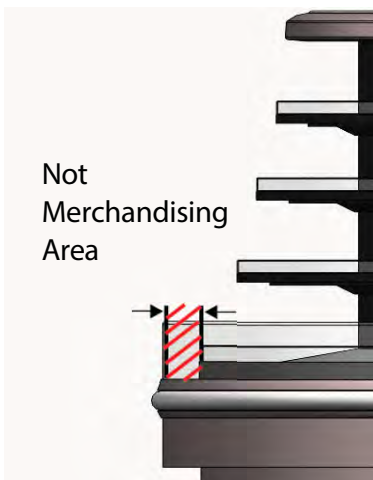

# Warning

Minimum Clearances for TY cases are to be followed as instructed for proper placement inside store locations.

- A minimum clearance of 15' from door opening must be maintained in order for case to remain in optimal performance.
- Side clearances are to be a minimum of 8' when placed next to a solid wall.
- Height clearance measured from floor follows as a minimum of 10' vertically.
- Minimum of 36" clearance if near an open aisle is required for optimal Air Curtain cycling.  
(Assumed 8' clearance from solid wall)

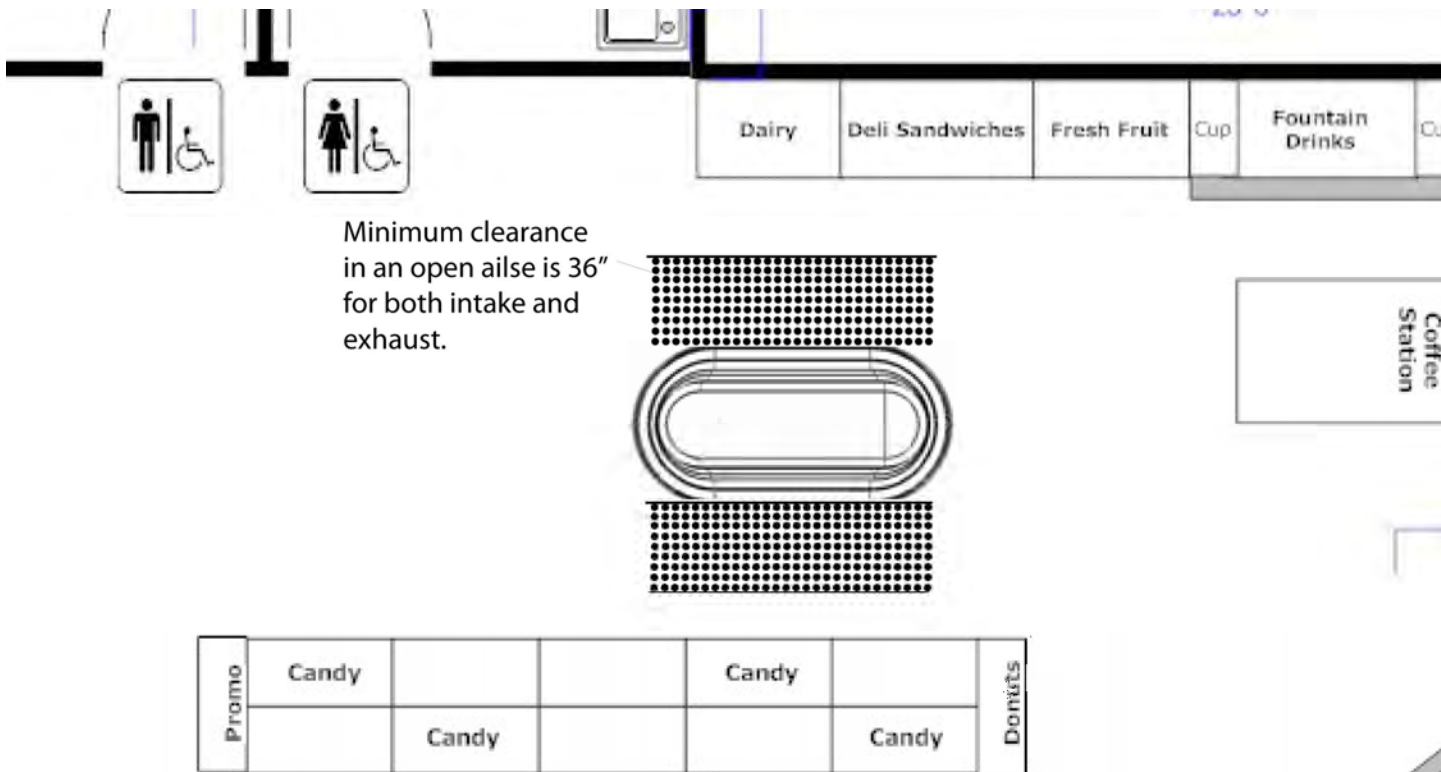

The following figure demonstrates proper clearances for Entyce cases assuming the surrounding walls are solid to ensure optimal performance of the cases Air Curtain.

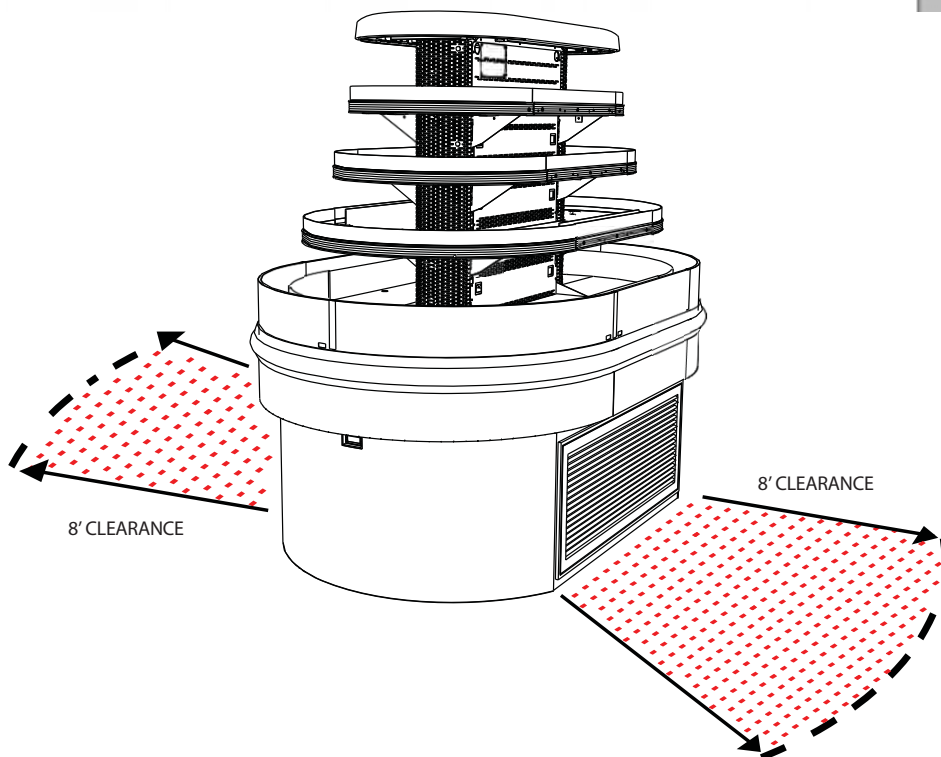

## Warning

Do not place merchandiser near any overhead vents or fans that may affect performance.



Do not place merchandiser in direct sunlight or sunlight through windows.

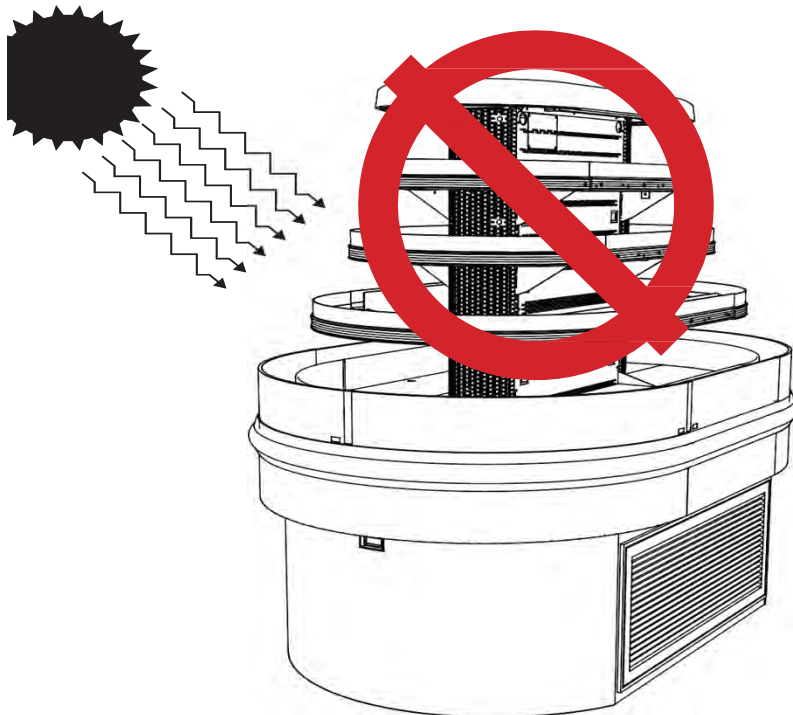

## General Information

### Case Description:

This Booklet specifically covers the following models:

- Entyce - TY3
- TY4

**Description:** Entyce A multi deck air curtain Self-Service case designed to display pre-packaged Deli, Bakery, Meat, Seafood, and/or Beverage products.

**Shipping Damage:** All equipment should be thoroughly examined for shipping damage before and during unloading. This equipment has been carefully inspected at our factory and the carrier has assumed responsibility for safe arrival. If damaged, either apparent or concealed, claim must be made to the carrier.

**Apparent Loss or Damage:** If there is an obvious loss or damage, it must be noted on the freight bill or express receipt and signed by the carrier's agent; otherwise, carrier may refuse claim. The carrier will supply necessary claim forms.

**Concealed Loss or Damage:** When loss or damage is not apparent until after all equipment is uncrated, a claim for concealed damage is made. Make request in writing to carrier for inspection within 15 days, and retain all packaging. The carrier will supply inspection report and required claim forms.

**Location/Store Conditions:** The refrigerated merchandisers have been designed for use only in air conditioned stores where temperature and humidity are maintained at 80°F and 55% relative humidity or 75°F and 55% relative humidity. DO NOT allow air conditioning, electric fans, ovens, open doors or windows (etc.) to create air currents around the merchandiser, as this will impair its correct operation.

**Shortages:** Check your shipment for any possible shortages of material. If a shortage should exist and is found to be the responsibility of Hussmann Chino, notify Hussmann Chino. If such a shortage involves the carrier, notify the carrier immediately, and request an inspection. Hussmann Chino will acknowledge shortages within ten days from receipt of equipment.

**Hussmann Chino Product Control:** The serial number and shipping date of all equipment has been recorded in Hussmann's files for warranty and replacement part purposes. All correspondence pertaining to warranty or parts ordering must include the serial number of each piece of equipment involved, in order to provide the customer with the correct parts.

**Keep this booklet with the case at all times for future reference.**

Keep this booklet with the case at all times for future reference.

## HUSSMANN®/CHINO

A publication of HUSSMANN® Chino  
 13770 Ramona Avenue • Chino, California 91710  
 (909) 628-8942 FAX  
 (909) 590-4910  
 (800) 395-9229



This equipment is to be installed to comply with the applicable NEC, Federal, State, and Local Plumbing and Construction Code having jurisdiction.

**TY3-4** 4' wide Merchandiser

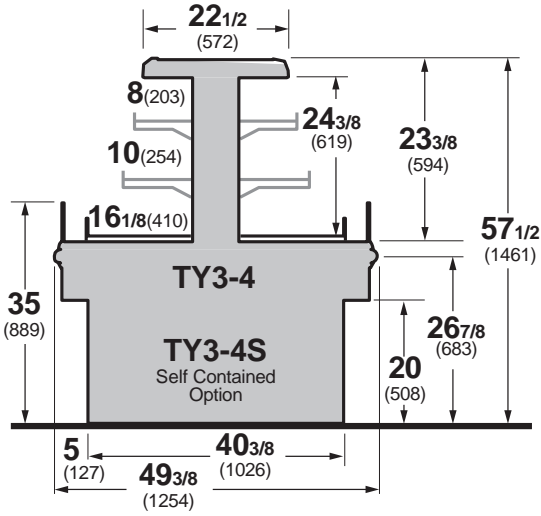

**TY4-4** 4' wide Merchandiser

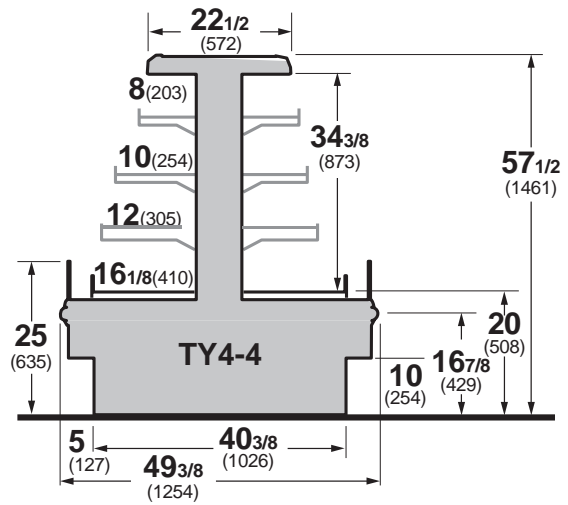

**TY3-5** Entyce 3 level 5' wide island

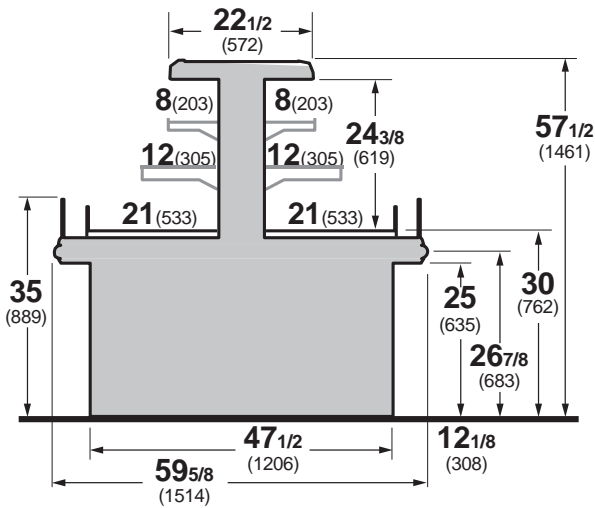

**TY4-6** Entyce 4 level 6' wide island

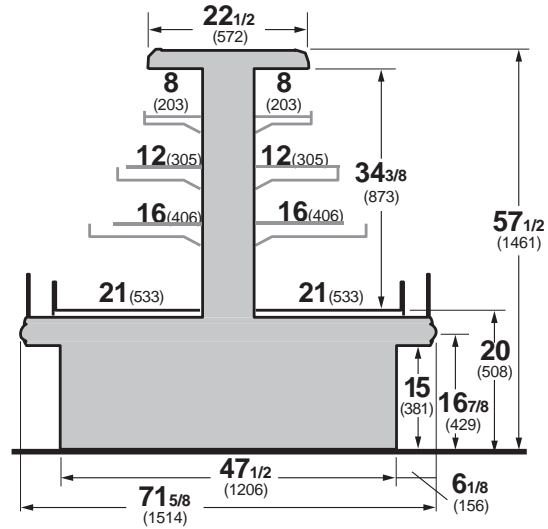

**TY3-6** 6' wide Merchandiser

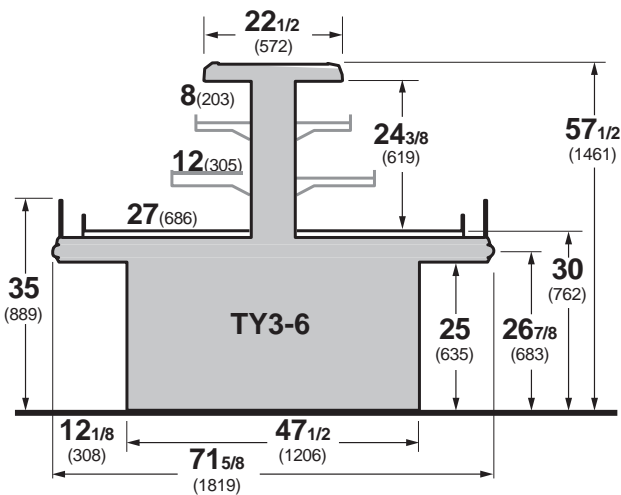

**TY4-6** 6' wide Merchandiser

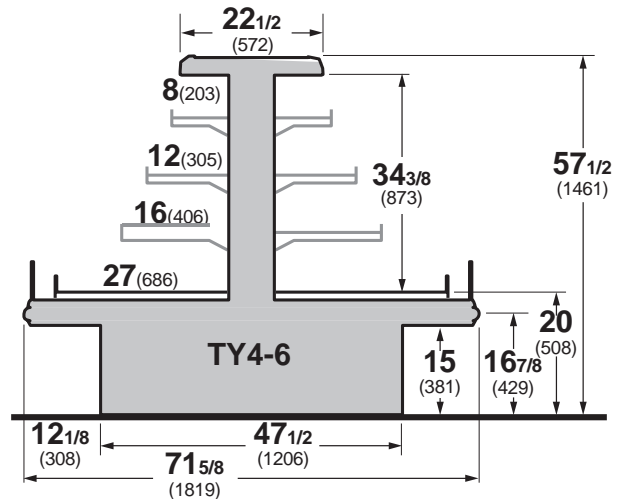

**TY-4** 4' wide Flat End Merchandiser

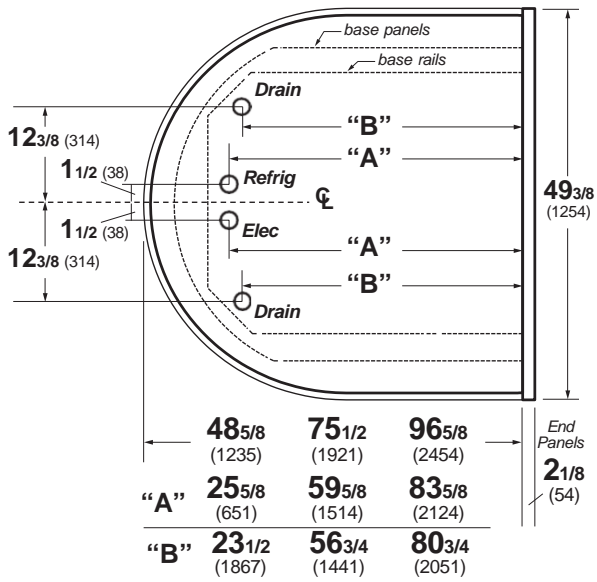

**TY3-6X**(case length) E - Flat End Merchandiser

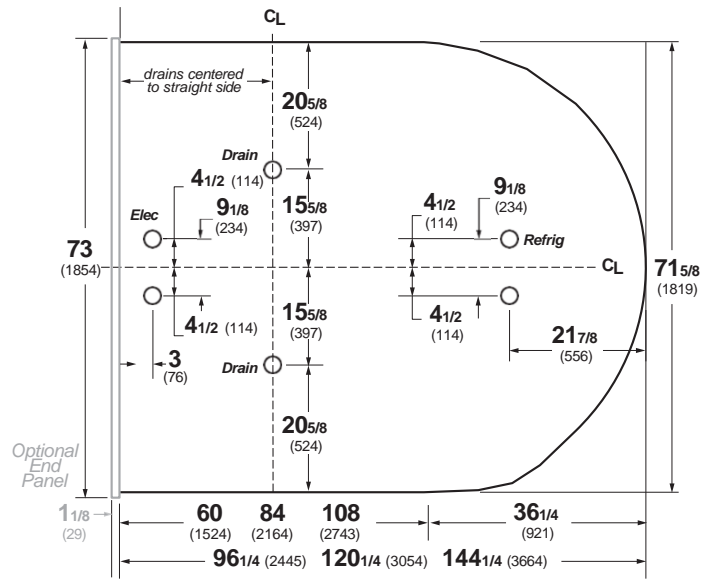

**TY-4** 4' wide Island Merchandiser

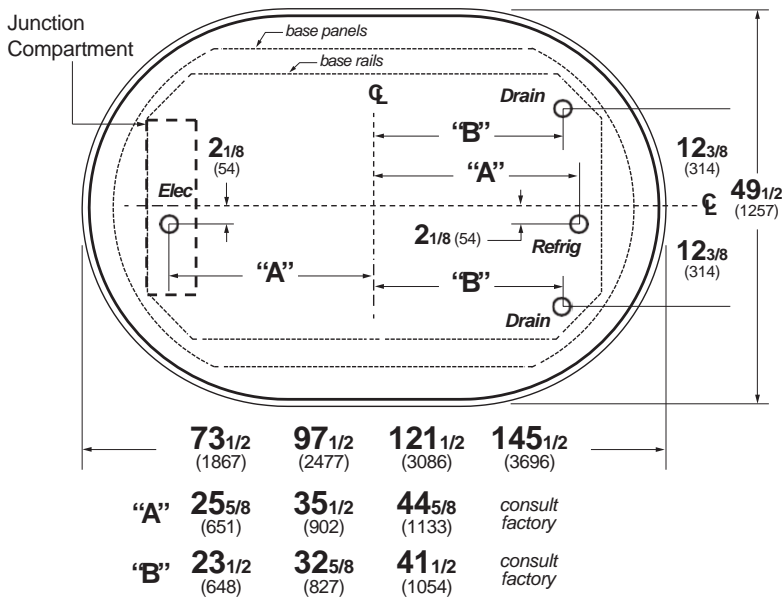

**TY3-6X**(case length) I - Island Merchandiser

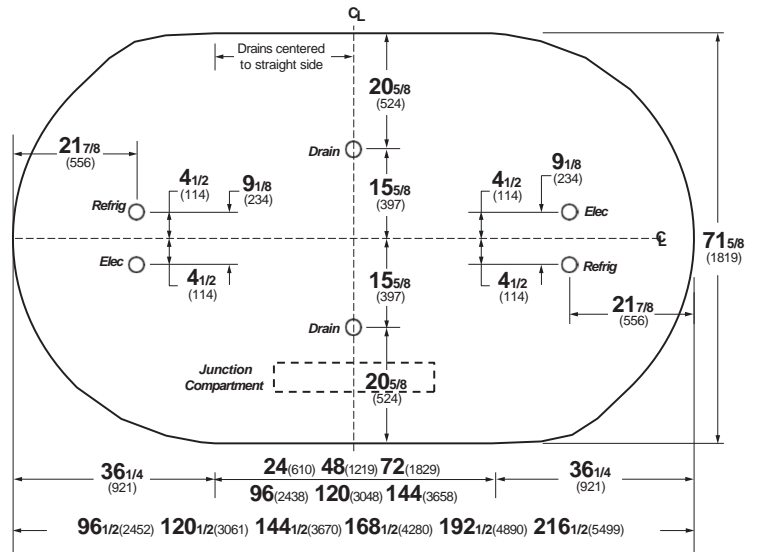

# Installation

## TY Lifting and Transport Instructions

1. The Entyce can be lifted by a forklift at typical lifting points.

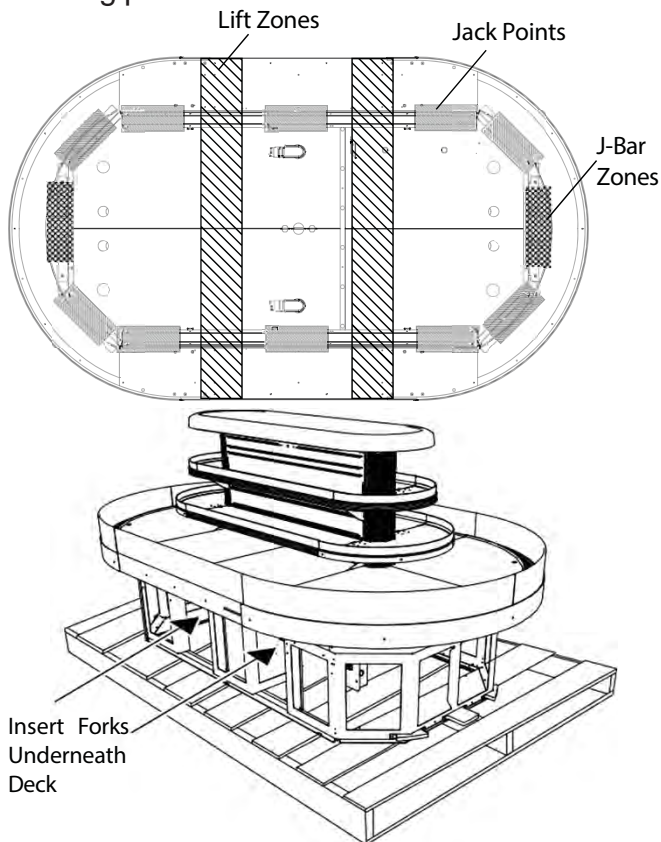

### **WARNING**

Improper placement of forks may damage drainage piping. Use a spotter when placing forks. Make sure that piping will not be damaged. Use J-Bars or Jacks if forks cannot be used safely

2. Ensure lower body panels are removed before lifting with a forklift. Serious damage will occur if the body panels are not removed.
3. Make sure that fork spacing and width will not damage drain or come in contact with piping, or electrical lines
4. Be sure that the forks are long enough to support beyond the center of the case but not damage near components. Check for proper balance before moving. A minimum fork length of 36" is recommended for 68" wide cases

5. The TY merchandiser can be raised at one end underneath the deck with a forklift to allow the placement of rollers or dollies.
6. Evenly support the entire base structure on rollers or dollies before attempting to move. Each Base Leg must have its own dolly to properly support the case.

Lifting Points are typical and dependent upon size of case and refrigeration application, drainage configurations will call for alterations in Lifting Zones.

Below are the following drainage configurations and lifting should be altered to the expected model.

### Full Side Drain

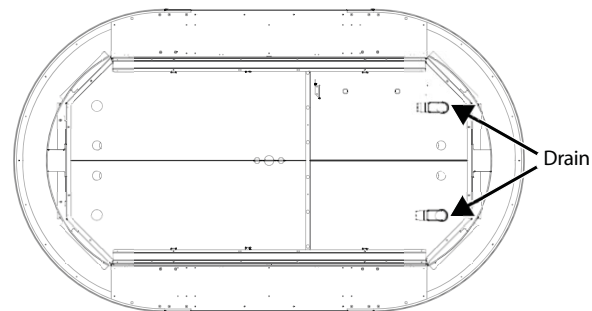

### Center Drain

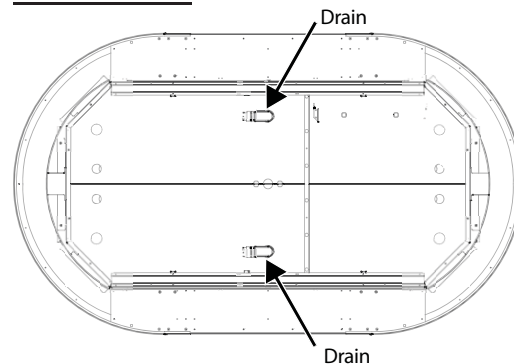

### Center Staggered Drain

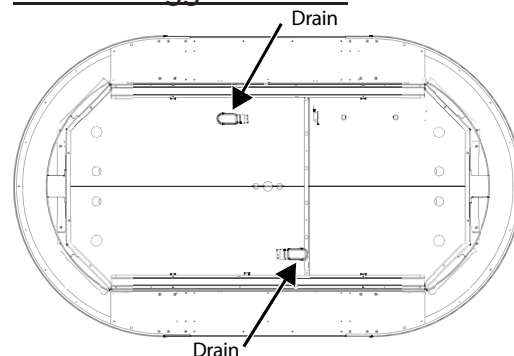

## Installation

### Location

The refrigerated merchandisers have been designed for use only in air conditioned stores where temperature and humidity are maintained at or 75°F and 55% relative humidity or below 80°F and 55% relative humidity. DO NOT allow air conditioning, electric fans, ovens, open doors or windows (etc.) to create air currents around the merchandiser, as this will impair its correct operation.



### Uncrating the Stand

Place the fixture as close to its permanent position as possible. Detach the walls from each other and remove from the skid. Unstrap the case from the skid. The fixture can now be lifted off the crate skid. **Lift only at base of stand!**

### Exterior Loading

These models have not been structurally designed to support excessive external loading. **Do not walk on their tops;** This could cause serious personal injury and damage to the fixture.



**ATTENTION  
INSTALLER**

**It is the contractor's responsibility to install case(s) according to local construction and health codes.**

### Leveling

**A LEVEL CASE IS NECESSARY TO INSURE PROPER OPERATION AND WATER DRAINAGE.** Note: A. To avoid removing concrete flooring, begin lineup leveling from the highest point of the store floor.

## Plumbing

### Waste Outlet and P-TRAP

The waste outlet is located in front and center of the case on both sides which allows for suitable access to each drain allowing drip piping to be run lengthwise under the fixture.

P-traps must be installed at the base of all refrigerated cases. The 1 1/2" P-TRAPS and threaded adapters must be installed to prevent air leakage and insect entrance into the fixture.

### Installing Condensate Drain

Poorly or improperly installed condensate drains can seriously restrict the operation of this refrigerator, and result in costly maintenance and product losses. Please follow the recommendations listed below when installing condensate drains to insure a proper installation:

1. Never use pipe for condensate drains smaller than the nominal diameter of the pipe or P-TRAP supplied with the case.
2. When connecting condensate drains, the P-TRAP must be used as part of the condensate drain to prevent air leakage or insect entrance. Store plumbing system floor drains should be at least 14" off the center of the case to allow use of the P-TRAP pipe section. Never use two water seals in series in any one line. Double P-TRAPS in series will cause a lock and prevent draining.

3. Always provide as much down hill slope ("fall") as possible; 1/8" per foot is the preferred minimum. PVC pipe, when used, must be supported to maintain the 1/8" pitch and to prevent warping.
4. Avoid long runs of condensate drains. Long runs make it impossible to provide the "fall" necessary for good drainage.
5. Provide a suitable air break between the flood rim of the floor drain and outlet of condensate drain. 1" is ideal.
6. Prevent condensate drains from freezing:
  - a. Do not install condensate drains in contact with non-insulated suction lines. Suction lines should be insulated with a nonabsorbent insulation material such as Armstrong's Armaflex.
  - b. Where condensate drains are located in dead air spaces (between refrigerators or between a refrigerator and a wall), provide means to prevent freezing. The water seal should be insulated to prevent condensation.

#### One Sided Drain

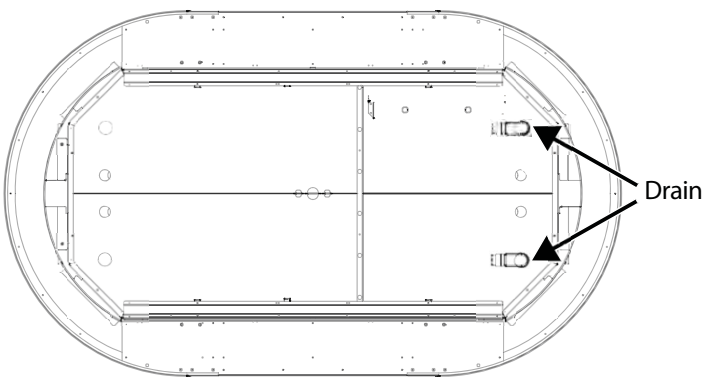

**Note: Cases are typical, length of cases vary**

#### Staggered Center Drain

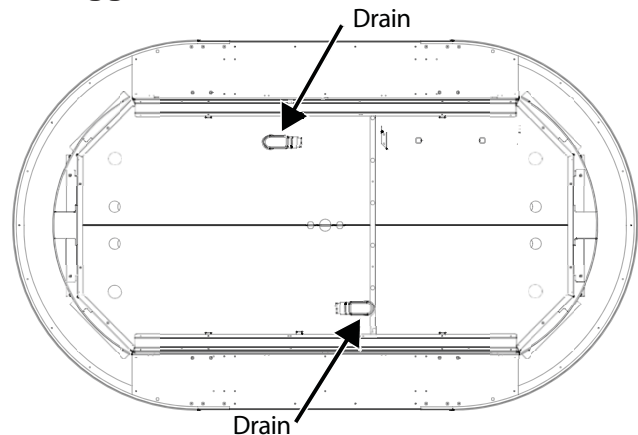

#### Center Drain

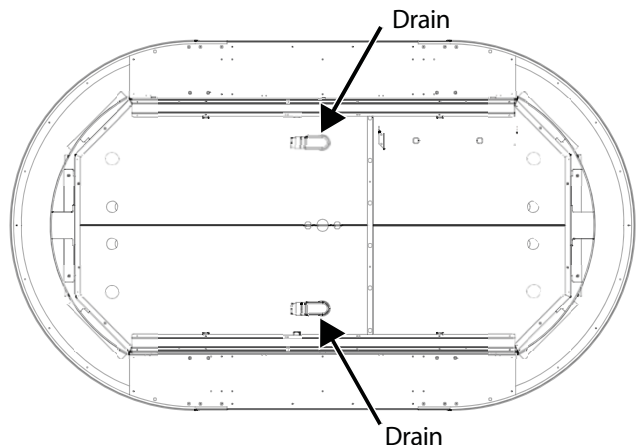

## Refrigeration Piping

The standard refrigerant will be R-404 unless otherwise specified on the customer order. Check the serial plate on the case for information. Refrigeration outlet access and the refrigeration components for the Entyce are situated on the left hand side near the centerline of the case to deliver optimal access which provides for easy installation and maintenance purposes without the probability of damaging any components.

### Refrigeration Lines

| <u>Liquid</u> | <u>Suction</u> |
|---------------|----------------|
| 3/8" O.D.     | 5/8" O.D.      |

Refrigerant lines should be sized as shown on the refrigeration legend furnished by the store.

Oil traps must be installed at the base of all suction line vertical risers on refrigerated cases.

Pressure drop can rob the system of capacity. To keep the pressure drop to a minimum, keep refrigerant line run as short as possible, using the minimum number of elbows. Where elbows are required, use long radius elbows only. All refrigeration components are located underneath the left hand side case deck pans.

**WARNING!**

**Do NOT apply thread sealer to ABS P-Trap.**



# Sump Pump Configuration

## Connecting Sump Lines

For Entyce cases with a Sump Pump Configuration connect liquid line, suction line, electrical, and drain line to top case stub-ups (outlets).

**Note: Isolate Drain line from Suction line either by seperating the lines or insulating the suction line.**

|              |      |          |
|--------------|------|----------|
| Liquid Line  | 1/2" | 85 fpm   |
| Suction Line | 7/8" | 1234 fpm |

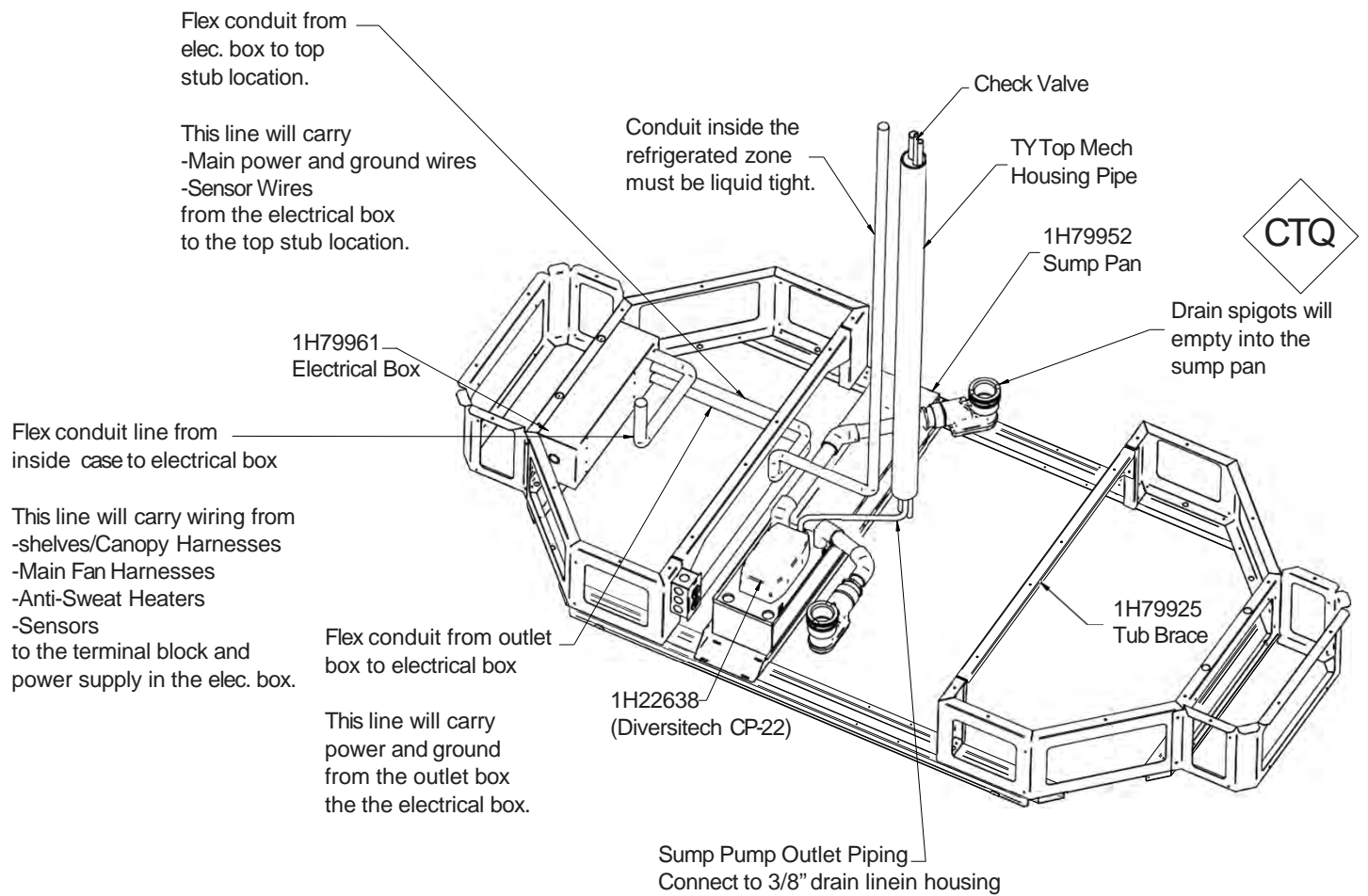
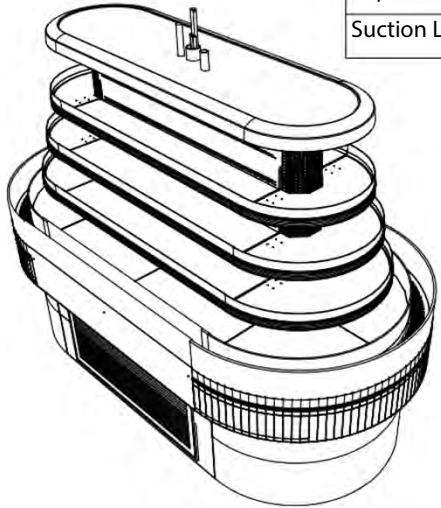

## Sealing Sump Lines

For Entyce cases with a Sump Pump Configuration connect liquid line, suction line, electrical, and drain line to top case stub-ups (outlets).

**Note:** Example below demonstrates the proper method of sealing refrigeration and electrical access points. Ensure tight seal to eliminate any air penetration.

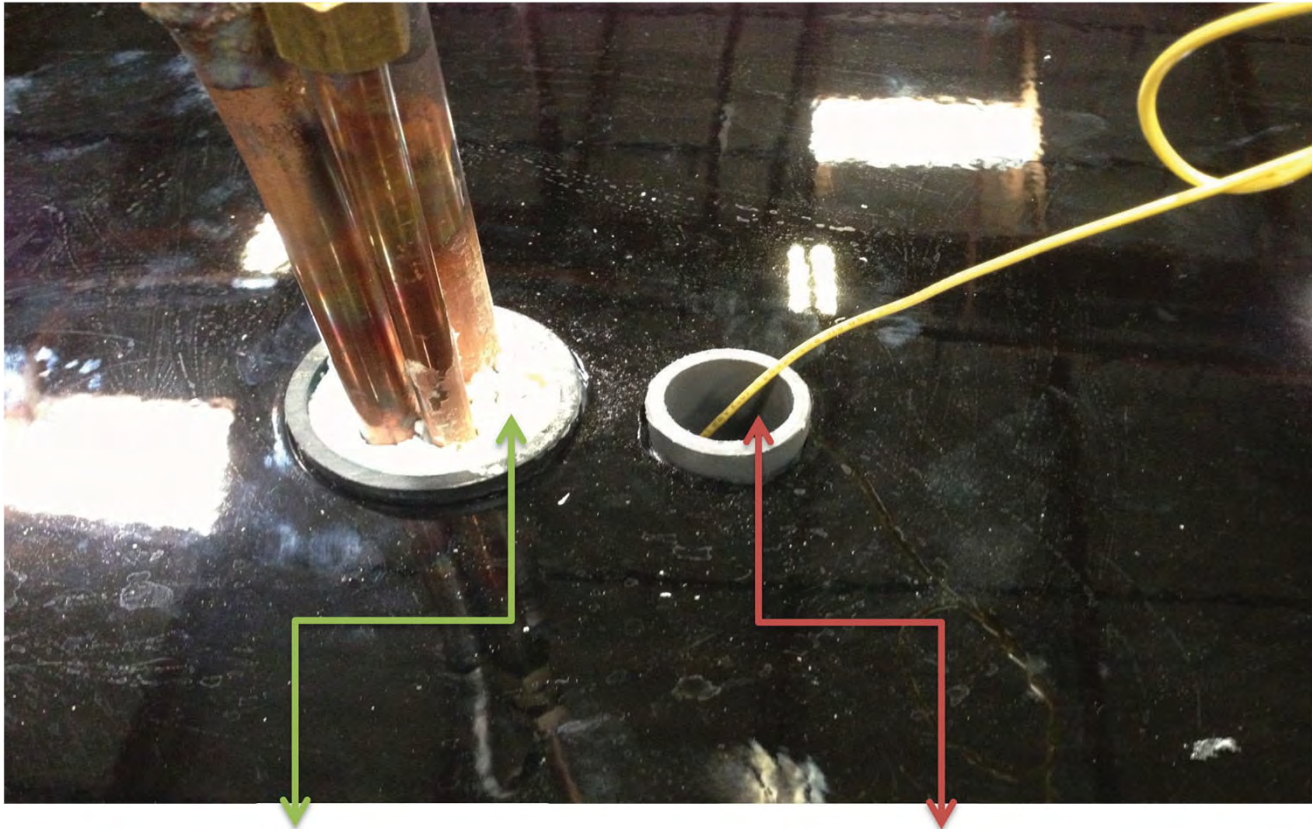

**Sealed refrigeration lines inside of pipe.**

**This is an EXAMPLE of how to properly seal electrical lines (using silicone) once electrical lines are pulled using provided wire-chase.**

**Installers: After running electrical you MUST seal top (shown here) and bottom of this pipe to eliminate any air penetration!**

**Failure to do so will cause condensation inside of pipe and water will drip on floor!**

**Silicone is an acceptable material to seal pipe.**



**DOE 2017**  
Energy Efficiency  
Compliant

Hussmann refrigerated merchandisers configured for sale for use in the United States meet or surpass the requirements of the DOE 2017 energy efficiency standards.

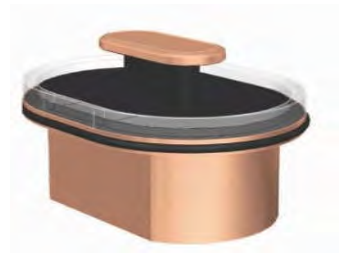

TY1-6 Single Level 6' wide Island

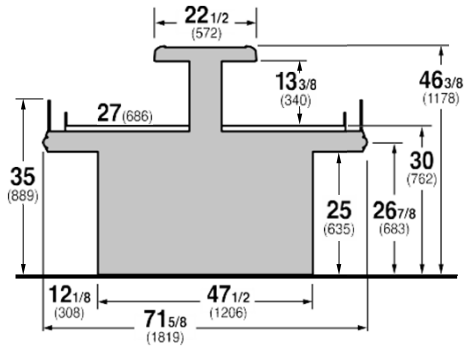

TY1-6X (case length) I - Island Merchandiser

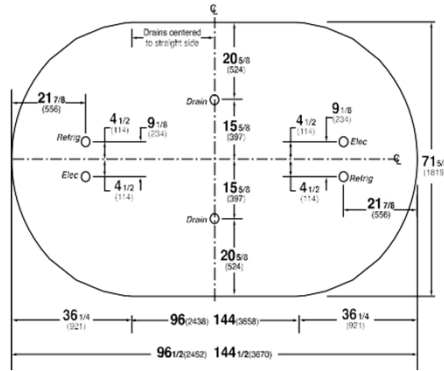

REFRIGERATION DATA:

| CASE LENGTHS | CASE USAGE | CAPACITY *** (BTU/HR) TOTAL |           | TEMPERATURE (°F) |           |                       | VELOCITY (FT/MIN) |
|--------------|------------|-----------------------------|-----------|------------------|-----------|-----------------------|-------------------|
|              |            | RATING CONDITION            |           | EVAPORATOR       |           | DISCHARGE AIR ** (°F) |                   |
|              |            | NSF 7                       | AHRI 1200 | NSF 7            | AHRI 1200 | NSF 7                 | NSF 7             |
| 8'-1         | DELI       | 9600                        | 9600      | 24               | 24        | 30-32                 | 150-200           |
| 12'-1        | DELI       | 14400                       | 14400     | 24               | 24        | 30-32                 | 150-200           |

| CASE LENGTHS | EST. REFG. CHR.G. 404A (LBS) | GLYCOL (20°F INLET, 6° RISE) |     |
|--------------|------------------------------|------------------------------|-----|
|              |                              | GPM                          | PSI |
| 8'-1         | 1.1                          | 3.4                          | 4.6 |
| 12'-1        | 1.8                          | 5.0                          | 4.4 |

\*\*FRONT DISCHARGE AIR MEASURED INSIDE AIR CURTAIN HONEYCOMB

\*\*\*REFRIGERATION NOTES:

- 1) BTUS DO NOT INCLUDE LIGHTS.
- 2) ADD 10 BTU'S PER FOOT OF LED SHELF LIGHTS PER LIGHT MATRIX BELOW.
- 3) AHRI 1200 RATING POINT FOR ENERGY CONSUMPTION COMPARISON ONLY.
- 4) USE DEW POINT FOR HIGH GLIDE REFRIGERANTS. CARE SHOULD BE TAKEN TO USE THE DEW POINT IN P/T TABLES FOR MEASURING AND ADJUSTING SUPERHEAT. ADJUST EVAPORATOR PRESSURE AS NEEDED TO MAINTAIN THE DISCHARGE AIR TEMPERATURE SHOWN.
- 5) RATING CONDITION IS NSF TYPE I, 75°F/55% RH.

REFRIGERATION DATA CONTINUED:

| ELEC. THERMOSTAT / AIR SENSOR SETTINGS |             |              | DEFROST TYPE | TIME (MIN) | DEFROST FREQUENCY (#/DAY) | TERM. TEMP (°F) COIL ONLY | DRIP TIME | DEFROST WATER (LBS/DAY/FT) |
|--|-------------|--------------|--------------|------------|---------------------------|---------------------------|-----------|----------------------------|
| USAGE                                  | CUT IN (°F) | CUT OUT (°F) |              |            |                           |                           |           |                            |
| DELI                                   | 32          | 29           | OFF TIME     | 16         | 12                        | 48                        | TBD       | 9.5                        |

| END PANEL WIDTH KEY |                     |                          |
|---------------------|---------------------|--------------------------|
| # OF END PNLS       | END PNL WIDTH (IN.) | TOTAL ADDED LENGTH (IN.) |
| 1                   | 1.125               | 1.125                    |

ELECTRICAL DATA:

STANDARD FANS, HEATERS, LED LIGHTS (115 VOLT)

| CASE LENGTH | EVAPORATOR FANS |                  |                 |      |       | CANOPY LIGHTS LED |       | OPTIONAL LED SHELF LIGHTS |       | MAX. LED LOAD (W/ ALL OPTIONS) |       | ANTI-SWEAT HEATERS (ON FAN CIRCUIT) |       | CONVENIENCE OUTLETS (OPTIONAL) |       |      | LIGHT MATRIX |
|-------------|-----------------|------------------|-----------------|------|-------|-------------------|-------|---------------------------|-------|--------------------------------|-------|-------------------------------------|-------|--------------------------------|-------|------|--------------|
|             | # OF EVAP FANS  | BLADE DIA. (IN.) | BLADE PITCH (°) | AMPS | WATTS | AMPS              | WATTS | AMPS                      | WATTS | AMPS                           | WATTS | AMPS                                | WATTS | # OUTLETS                      | VOLTS | AMPS | FT OF LEDS   |
| 8'-1        | 6               | 8                | 10              | 1.8  | 48    | 0.12              | 14    | N/A                       | N/A   | 0.12                           | 14    | 0.43                                | 50    | 1                              | 115   | 15   | 6            |
| 12'-1       | 10              | 8                | 10              | 3    | 80    | 0.30              | 35    | N/A                       | N/A   | 0.30                           | 35    | 0.78                                | 90    | 1                              | 115   | 15   | 14           |

OPTIONAL HIGH OUTPUT LED LIGHTS (115 VOLT)

| CASE LENGTH | CANOPY LIGHTS H.O. LED |       | OPTIONAL SHELF |       | MAX. H.O. LED LOAD |       |
|-------------|------------------------|-------|----------------|-------|--------------------|-------|
|             | AMPS                   | WATTS | AMPS           | WATTS | AMPS               | WATTS |
| 8'-1        | N/A                    | N/A   | N/A            | N/A   | N/A                | N/A   |
| 12'-1       | N/A                    | N/A   | N/A            | N/A   | N/A                | N/A   |



**SELF-SERVICE DELI CHEESE**

HUSSMANN - TY3-5 I-ISLAND (CHINO)



Hussmann refrigerated merchandisers configured for sale for use in the United States meet or surpass the requirements of the DOE 2017 energy efficiency standards.

REVISION DATE 03/21/17

**TY3-5** Entyce 3 level 5' wide island

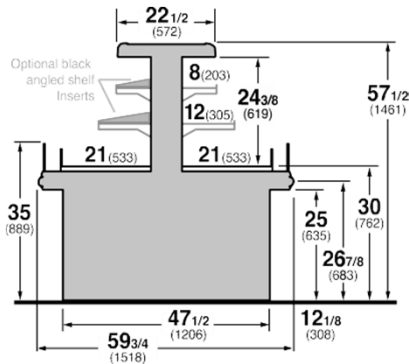

**TY3-5, TY4-5** 5' wide Island Merchandiser

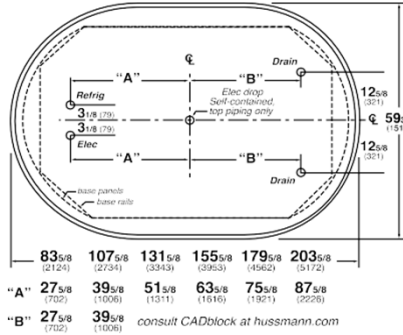

**REFRIGERATION DATA:**

| CASE LENGTHS | CASE USAGE    | CAPACITY *** (BTU/HR) |           | TEMPERATURE (°F) |           |                       | VELOCITY (FT/MIN) |
|--------------|---------------|-----------------------|-----------|------------------|-----------|-----------------------|-------------------|
|              |               | RATING CONDITION      |           | EVAPORATOR       |           | DISCHARGE AIR ** (°F) |                   |
|              |               | NSF 7                 | AHRI 1200 | NSF 7            | AHRI 1200 | NSF 7                 |                   |
| 71           | DELI / CHEESE | 10770                 | 10770     | 26               | 26        | 30-33                 | 175-250           |
| 91           | DELI / CHEESE | 13790                 | 13790     | 26               | 26        | 30-33                 | 175-250           |
| 111          | DELI / CHEESE | 16810                 | 16810     | 26               | 26        | 30-33                 | 175-250           |
| 131          | DELI / CHEESE | 19830                 | 19830     | 26               | 26        | 30-33                 | 175-250           |
| 151          | DELI / CHEESE | 22850                 | 22850     | 26               | 26        | 30-33                 | 175-250           |
| 171          | DELI / CHEESE | 25870                 | 25870     | 26               | 26        | 30-33                 | 175-250           |

| CASE LENGTHS | EST. REFG. CHR.G. (LBS) | 20°F GLYCOL 6° RISE |     |
|--------------|-------------------------|---------------------|-----|
|              |                         | GPM                 | PSI |
| 71           | 1.1                     | 3.8                 | 5.2 |
| 91           | 1.3                     | 4.8                 | 3.8 |
| 111          | 1.8                     | 5.8                 | 5.1 |
| 131          | 2.2                     | 6.7                 | 6.7 |
| 151          | 2.7                     | 7.6                 | 4.7 |
| 171          | 3.1                     | 8.5                 | 5.4 |

\*\*FRONT DISCHARGE AIR MEASURED INSIDE AIR CURTAIN HONEYCOMB

\*\*\*REFRIGERATION NOTES:

- 1) BTUS ARE SHOWN WITHOUT LIGHTS
- 2) ADD 10 BTU/FT OF LED LIGHTS PER LIGHT MATRIX BELOW
- 3) AHRI 1200 RATING POINT FOR ENERGY CONSUMPTION COMPARISON ONLY
- 4) USE DEW POINT FOR HIGH GLIDE REFRIGERANTS. CARE SHOULD BE TAKEN TO USE THE DEW POINT IN P/T TABLES FOR MEASURING AND ADJUSTING SUPERHEAT. ADJUST EVAPORATOR PRESSURE AS NEEDED TO MAINTAIN THE DISCHARGE AIR TEMPERATURE SHOWN.
- 5) RATING CONDITION IS NSF TYPE I, 75°F/55% RH

**REFRIGERATION DATA CONTINUED:**

| SENSOR SETTINGS |             | DEFROST TYPE | TIME (MIN) | DEFROST FREQUENCY (#/DAY) | TERM. TEMP (°F) COIL ONLY | DRIP TIME | DEFROST WATER (LBS/DAY/FT) |
|-----------------|-------------|--------------|------------|---------------------------|---------------------------|-----------|----------------------------|
| USAGE           | CUT IN (°F) |              |            |                           |                           |           |                            |
| DELI / CHEESE   | 33          | OFF TIME     | 16         | 12                        | 48                        | N/A       | 11                         |

| END PANEL WIDTH KEY |                     |                          |
|---------------------|---------------------|--------------------------|
| # OF END PNLS       | END PNL WIDTH (IN.) | TOTAL ADDED LENGTH (IN.) |
| 1                   | 1.125               | 1.125                    |
| 2                   | 1.125               | 2.25                     |

**ELECTRICAL DATA:**

**STANDARD FANS, HEATERS, LED LIGHTS (115 VOLT)**

| CASE LENGTH | EVAPORATOR FANS |                  |                 |      |       | CANOPY LIGHTS LED |       | OPTIONAL LED SHELF LIGHTS |        | MAX. LED LOAD (W/ ALL OPTIONS) |       | ANTI-SWEAT HEATERS (ON FAN CIRCUIT) |       | CONVENIENCE OUTLETS (OPTIONAL) |       |      | LIGHT MATRIX FEET |
|-------------|-----------------|------------------|-----------------|------|-------|-------------------|-------|---------------------------|--------|--------------------------------|-------|-------------------------------------|-------|--------------------------------|-------|------|-------------------|
|             | # OF EVAP FANS  | BLADE DIA. (IN.) | BLADE PITCH (°) | AMPS | WATTS | AMPS              | WATTS | AMPS                      | WATTS  | AMPS                           | WATTS | AMPS                                | WATTS | # OUTLETS                      | VOLTS | AMPS |                   |
| 71          | 6               | 8                | 15              | 1.8  | 48    | 0.12              | 14.27 | 0.29                      | 32.99  | 0.41                           | 47    | 0.43                                | 50    | 1                              | 115   | 15   | 22                |
| 91          | 8               | 8                | 15              | 2.4  | 64    | 0.22              | 25.04 | 0.47                      | 54.52  | 0.69                           | 80    | 0.61                                | 70    | 1                              | 115   | 15   | 34                |
| 111         | 10              | 8                | 15              | 3.0  | 80    | 0.30              | 34.87 | 0.65                      | 74.18  | 0.95                           | 109   | 0.78                                | 90    | 1                              | 115   | 15   | 46                |
| 131         | 12              | 8                | 10              | 3.6  | 96    | 0.40              | 45.63 | 0.83                      | 95.71  | 1.23                           | 141   | 0.96                                | 110   | 1                              | 115   | 15   | 58                |
| 151         | 14              | 8                | 10              | 4.2  | 112   | 0.49              | 56.39 | 1.02                      | 117.23 | 1.51                           | 174   | 1.04                                | 120   | 1                              | 115   | 15   | 70                |
| 171         | 16              | 8                | 10              | 4.8  | 128   | 0.57              | 65.29 | 1.17                      | 135.02 | 1.74                           | 200   | 1.22                                | 140   | 1                              | 115   | 15   | 82                |

**OPTIONAL HIGH OUTPUT LED LIGHTS (115 VOLT)**

| CASE LENGTH | CANOPY LIGHTS H.O. LED |       | OPTIONAL SHELF |       | MAX. H.O. LED LOAD |       |
|-------------|------------------------|-------|----------------|-------|--------------------|-------|
|             | AMPS                   | WATTS | AMPS           | WATTS | AMPS               | WATTS |
| 71          | N/A                    | N/A   | N/A            | N/A   | N/A                | N/A   |
| 91          | N/A                    | N/A   | N/A            | N/A   | N/A                | N/A   |
| 111         | N/A                    | N/A   | N/A            | N/A   | N/A                | N/A   |
| 131         | N/A                    | N/A   | N/A            | N/A   | N/A                | N/A   |
| 151         | N/A                    | N/A   | N/A            | N/A   | N/A                | N/A   |
| 171         | N/A                    | N/A   | N/A            | N/A   | N/A                | N/A   |



**SELF-SERVICE DELI CHEESE**  
**HUSSMANN - TY4-5 ISLAND (CHINO)**

REVISION DATE 6/20/2018



Hussmann refrigerated merchandisers configured for sale for use in the United States meet or surpass the requirements of the DOE 2017 energy efficiency standards.

**TY-5 5' wide Island Merchandiser**

TY4-5 Entyce 4 level 5' wide island

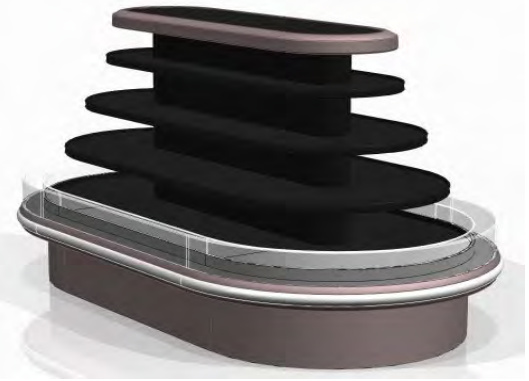
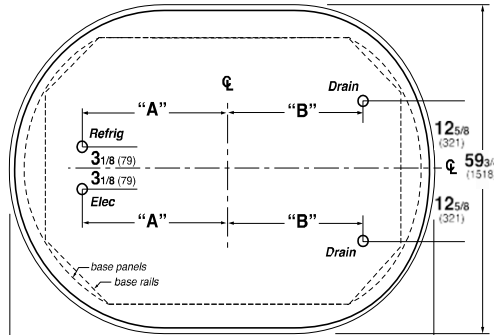
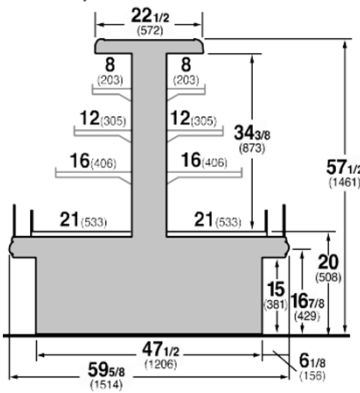

|     |                             |                              |                                  |                              |                              |                              |
|-----|-----------------------------|------------------------------|----------------------------------|------------------------------|------------------------------|------------------------------|
|     | 83 <sup>5/8</sup><br>(2124) | 107 <sup>5/8</sup><br>(2734) | 131 <sup>5/8</sup><br>(3343)     | 155 <sup>5/8</sup><br>(3953) | 179 <sup>5/8</sup><br>(4562) | 203 <sup>5/8</sup><br>(5172) |
| "A" | 27 <sup>5/8</sup><br>(702)  | 39 <sup>5/8</sup><br>(1006)  | 51 <sup>5/8</sup><br>(1311)      | 63 <sup>5/8</sup><br>(1616)  | 75 <sup>5/8</sup><br>(1921)  | 87 <sup>5/8</sup><br>(2226)  |
| "B" | 27 <sup>5/8</sup><br>(702)  | 39 <sup>5/8</sup><br>(1006)  | consult CADblock at hussmann.com |                              |                              |                              |

**REFRIGERATION DATA:**

| CASE LENGTHS | CASE USAGE | CAPACITY ***<br>(BTU/HR) |              | TEMPERATURE (°F) |              |                          | VELOCITY<br>(FT/MIN) |
|--------------|------------|--------------------------|--------------|------------------|--------------|--------------------------|----------------------|
|              |            | RATING<br>CONDITION      |              | EVAPORATOR       |              | DISCHARGE<br>AIR ** (°F) |                      |
|              |            | NSF 7                    | AHRI<br>1200 | NSF 7            | AHRI<br>1200 | NSF 7                    |                      |
| 7I           | DELI /     | 13660                    | 13660        | 22               | 22           | 28-30                    | 100-150              |
| 9I           | DELI /     | 17500                    | 17500        | 22               | 22           | 28-30                    | 100-150              |
| 11I          | DELI /     | 21340                    | 21340        | 22               | 22           | 28-30                    | 100-150              |
| 13I          | DELI /     | 25180                    | 25180        | 22               | 22           | 28-30                    | 100-150              |
| 15I          | DELI /     | 29000                    | 29000        | 22               | 22           | 28-30                    | 100-150              |
| 17I          | DELI /     | 32850                    | 32850        | 22               | 22           | 28-30                    | 100-150              |

| CASE LENGTHS | EST. REFG. CHR.G. 404A (LBS) | GLYCOL (20°F INLET, 6° RISE) |     |
|--------------|------------------------------|------------------------------|-----|
|              |                              | GPM                          | PSI |
| 7I           | 1.1                          | 4.8                          | 6.8 |
| 9I           | 1.3                          | 6.2                          | 4.9 |
| 11I          | 1.8                          | 7.4                          | 6.7 |
| 13I          | 2.2                          | 8.7                          | 8.7 |
| 15I          | 2.7                          | 9.8                          | 6.1 |
| 17I          | 3.1                          | 11.0                         | 7.0 |

\*\*FRONT DISCHARGE AIR MEASURED INSIDE AIR CURTAIN HONEYCOMB

\*\*\*REFRIGERATION NOTES:

- 1) BTU'S SHOWN ARE WITHOUT LIGHTS.
- 2) ADD 10 BTU'S PER FOOT OF LED LIGHTS PER LIGHT MATRIX BELOW.
- 3) AHRI 1200 RATING POINT FOR ENERGY CONSUMPTION COMPARISON ONLY.
- 4) USE DEW POINT FOR HIGH GLIDE REFRIGERANTS. CARE SHOULD BE TAKEN TO USE THE DEW POINT IN P/T TABLES FOR MEASURING AND ADJUSTING SUPERHEAT. ADJUST EVAPORATOR PRESSURE AS NEEDED TO MAINTAIN THE DISCHARGE AIR TEMPERATURE SHOWN.
- 5) RATING CONDITION IS NSF TYPE I, 75°F/55% RH.

**REFRIGERATION DATA CONTINUED:**

| ELEC. THERMOSTAT / AIR SENSOR SETTINGS |             | DEFROST TYPE | TIME (MIN) | DEFROST FREQUENCY (#/DAY) | TERM. TEMP (°F) COIL ONLY | DRIP TIME | DEFROST WATER (LBS/DAY/FT) |
|--|-------------|--------------|------------|---------------------------|---------------------------|-----------|----------------------------|
| USAGE                                  | CUT IN (°F) |              |            |                           |                           |           |                            |
| DELI / CHEESE                          | 31          | 28           | OFF TIME   | 16                        | 12                        | N/A       | 12                         |

| END PANEL WIDTH KEY |                     |                          |
|---------------------|---------------------|--------------------------|
| # OF END PNLS       | END PNL WIDTH (IN.) | TOTAL ADDED LENGTH (IN.) |
| 1                   | 1.125               | 1.125                    |
| 2                   | 1.125               | 2.25                     |

**ELECTRICAL DATA:**

**STANDARD FANS, HEATERS, LED LIGHTS (115 VOLT)**

| CASE LENGTH | EVAPORATOR FANS |                  |                 |      | CANOPY LIGHTS LED |      | OPTIONAL LED SHELF LIGHTS |      | MAX. LED LOAD (W/ ALL OPTIONS) |      | ANTI-SWEAT HEATERS (ON FAN CIRCUIT) |      | CONVENIENCE OUTLETS (OPTIONAL) |           |       | LIGHT MATRIX |      |
|-------------|-----------------|------------------|-----------------|------|-------------------|------|---------------------------|------|--------------------------------|------|-------------------------------------|------|--------------------------------|-----------|-------|--------------|------|
|             | # OF EVAP FANS  | BLADE DIA. (IN.) | BLADE PITCH (°) | AMPS | WATTS             | AMPS | WATTS                     | AMPS | WATTS                          | AMPS | WATTS                               | AMPS | WATTS                          | # OUTLETS | VOLTS |              | AMPS |
| 7I          | 6               | 8                | 20              | 1.8  | 48                | 0.12 | 14                        | 0.57 | 66                             | 0.70 | 80                                  | 0.43 | 50                             | 1         | 115   | 15           | 34   |
| 9I          | 8               | 8                | 20              | 2.4  | 64                | 0.22 | 25                        | 0.85 | 98                             | 1.07 | 123                                 | 0.61 | 70                             | 1         | 115   | 15           | 50   |
| 11I         | 10              | 8                | 20              | 3    | 80                | 0.30 | 35                        | 1.11 | 128                            | 1.41 | 162                                 | 0.78 | 90                             | 1         | 115   | 15           | 66   |
| 13I         | 12              | 8                | 15              | 3.6  | 96                | 0.40 | 46                        | 1.39 | 160                            | 1.79 | 205                                 | 0.96 | 110                            | 1         | 115   | 15           | 82   |
| 15I         | 14              | 8                | 15              | 4.2  | 112               | 0.49 | 56                        | 1.67 | 192                            | 2.16 | 249                                 | 1.04 | 120                            | 1         | 115   | 15           | 98   |
| 17I         | 16              | 8                | 15              | 4.8  | 128               | 0.57 | 65                        | 1.90 | 219                            | 2.47 | 284                                 | 1.22 | 140                            | 1         | 115   | 15           | 114  |

**OPTIONAL HIGH OUTPUT LED LIGHTS (115 VOLT)**

| CASE LENGTH | CANOPY LIGHTS H.O. LED |       | OPTIONAL SHELF |       | MAX. H.O. LED LOAD |       |
|-------------|------------------------|-------|----------------|-------|--------------------|-------|
|             | AMPS                   | WATTS | AMPS           | WATTS | AMPS               | WATTS |
| 7I          | N/A                    | N/A   | N/A            | N/A   | N/A                | N/A   |
| 9I          | N/A                    | N/A   | N/A            | N/A   | N/A                | N/A   |
| 11I         | N/A                    | N/A   | N/A            | N/A   | N/A                | N/A   |
| 13I         | N/A                    | N/A   | N/A            | N/A   | N/A                | N/A   |
| 15I         | N/A                    | N/A   | N/A            | N/A   | N/A                | N/A   |
| 17I         | N/A                    | N/A   | N/A            | N/A   | N/A                | N/A   |

## Electrical

| STANDARD CASE WIRE COLOR CODE<br>CODIGO DE COLORES DE LOS ALAMBRES PARA LAS VITRINAS ESTANDAR<br>CODE COULEUR POUR FILS DE BOITIER NORMALISE |                               |                              |
|--|-------------------------------|------------------------------|
| COLOR DESCRIPTION  | DESCRIPCION                   | DESCRIPTION                  |
| ■ GROUND   | TIERRA MASA                   | MASSE                        |
| ■ ANTI-SWEAT   | ANTICONDENSACION              | ANTI-SUINTEMENT              |
| ■ LIGHTS   | LUCES                         | ECLAIRAGE                    |
| ■ RECEPTACLES  | ENCHUFES                      | PRISE DE COURANT             |
| ■ T-STAT/SOLENOID 230VAC   | TERMOSTATO/SOLENOIDE (230VAC) | SOUPAPE A SOLENOID (230 VAC) |
| ■ T-STAT/SOLENOID 115VAC   | TERMOSTATO/SOLENOIDE (115VAC) | SOUPAPE A SOLENOID (115 VAC) |
| ■ T-STAT/SOLENOID 24VAC  | TERMOSTATO/SOLENOIDE (24VAC)  | SOUPAPE A SOLENOID (24 VAC)  |
| ■ FAN MOTORS   | VENTILADORES                  | VENTILATEUR                  |
| BLUE CONDENSING UNIT   | UNIDAD DE CONDENSACION        | UNITE DE CONDENSATION        |

**USE COPPER CONDUCTORS ONLY**  
**UTILISEZ LES CONDUCTEURS DE CUIVRE SEULEMENT**  
**UTILICE LOS CONDUCTORES DE COBRE SOLAMENTE**  
 430-01-0338 R101003

### **CASE MUST BE GROUNDED**

**NOTE:** Refer to label affixed to case to determine the actual configuration as checked in the "TYPE INSTALLED" boxes.

Standard lighting for all refrigerated models will be full length LED Lights located within the case at the top.

## Field Wiring and Serial Plate Amperage

Field Wiring must be sized for component amperes printed on the serial plate. Actual ampere draw may be less than specified. Field wiring from the refrigeration control panel to the merchandisers is required for refrigeration thermostats. Case amperes are listed on the wiring diagram, but always check the serial plate.



**DANGER**

**BEFORE SERVICING  
 ALWAYS DISCONNECT ELECTRICAL  
 POWER AT THE MAIN DISCONNECT  
 WHEN SERVICING OR REPLACING ANY  
 ELECTRICAL COMPONENT.  
 This includes (but not limited to) Fans, Heaters  
 Thermostats, and Lights.**

**Wiring Diagrams Index**

|            |                |            |                |
|------------|----------------|------------|----------------|
| <b>TY1</b> | <b>5X7I-R</b>  | <b>7'</b>  | <b>3053753</b> |
|            | <b>6X8I-R</b>  | <b>8'</b>  | <b>3008179</b> |
|            | <b>6X12I-R</b> | <b>12'</b> | <b>3014692</b> |

|            |   |            |                |
|------------|---|------------|----------------|
| <b>TY3</b> | <b>4X6I-R</b>                             | <b>6'</b>  | <b>1H85155</b> |
|            | <b>4X8I-R</b>                             | <b>8'</b>  | <b>1H91354</b> |
|            | <b>4X10I-R</b>                            | <b>10'</b> | <b>3047530</b> |
|            | <b>4X12I-R</b>                            | <b>12'</b> | <b>3008178</b> |
|            | <b>5X7I-R</b>                             | <b>7'</b>  | <b>3008177</b> |
|            | <b>5X9I-R</b>                             | <b>9'</b>  | <b>2H00213</b> |
|            | <b>5X11I-R</b>                            | <b>11'</b> | <b>1H86614</b> |
|            | <b>5X13I-R</b>                            | <b>13'</b> | <b>3008175</b> |
|            | <b>6X8C-R</b>                             | <b>8'</b>  | <b>3013478</b> |
|            | <b>6X8I-R</b>                             | <b>8'</b>  | <b>1H86612</b> |
|            | <b>ECSQ-6X8I-R</b>                        | <b>8'</b>  | <b>3017118</b> |
|            | <b>6X10I-R</b>                            | <b>10'</b> | <b>1H78139</b> |
|            | <b>6X12I-R</b>                            | <b>12'</b> | <b>3047528</b> |
|            | <b>ECSQ-6X12I-R</b>                       | <b>12'</b> | <b>3048459</b> |
|            | <b>6X14I-R</b>                            | <b>14'</b> | <b>1H77864</b> |
|            | <b>ECRC-6X14I-R</b>                       | <b>14'</b> | <b>3055337</b> |
|            | <b>6X16I-R</b>                            | <b>16'</b> | <b>1H93522</b> |
|            | <b>ECRC-6X16I-R 10" &amp; 14" SHELVES</b> | <b>16'</b> | <b>3059427</b> |
|            | <b>6X18I-R</b>                            | <b>18'</b> | <b>3013482</b> |

## Wiring Diagrams Index (cont'd)

|     |   |     |         |
|-----|---|-----|---------|
| TY4 | 4X6I-R                                    | 6'  | 3047021 |
|     | 4X10I-R                                   | 10' | 3013474 |
|     | 4X12I-R                                   | 12' | 1H89619 |
|     | 5X7I-R                                    | 7'  | 2H00212 |
|     | ECRC-5X7I-R                               | 7'  | 3144548 |
|     | TY4EC-5X7I-R                              | 7'  | 3078669 |
|     | 5X9I-R                                    | 9'  | 2H14403 |
|     | 5X11I-R                                   | 11' | 1H92381 |
|     | 5X12C-R                                   | 12' | 3142085 |
|     | TY4EC-5X13I-R W/OPTIONAL SUMP PUMP        | 13' | 2H22482 |
|     | TY4EC-5X13I-R 8",10",12" SHELVES          | 13' | 3030997 |
|     | TY4EC-5X17I-R, 10",12",14" SHELVES        | 17' | 3058176 |
|     | 5X13I-R                                   | 13' | 2H01103 |
|     | 5X15I-R                                   | 15' | 1H92380 |
|     | 5X17I-R                                   | 17' | 3008164 |
|     | 6X8C-R                                    | 8'  | 1H89148 |
|     | TY4ECRC-6X8I-R ULTRA LED TOP, 12",14",16" | 8'  | 3107535 |
|     | TY4ECRC-6X8I-R ULTRA LED TOP, 10",12",16" | 8'  | 3123818 |
|     | TY4ECRC-6X8C-R HO CANOPY LIGHTS           | 8'  | 3064025 |
|     | 6X8I-R                                    | 8'  | 1H85454 |
|     | 6X10I-R                                   | 10' | 1H93524 |
|     | 6X12I-R                                   | 12' | 1H91310 |
|     | TY4ECRC-6X12I-R 12" & 16" SHELVES         | 12' | 3047242 |
|     | TY4ECRC-6X12I-R 10",12" & 14" SHELVES     | 12' | 3080512 |
|     | TY4ECRC-6X12I-R 12",14" & 16" SHELVES     | 12' | 3092240 |
|     | 6X14I-R                                   | 14' | 1H84139 |
|     | TY4ECRC-6X14I-R                           | 14' | 3047157 |
|     | 6X16I-R                                   | 16' | 1H85195 |
|     | TY4ECRC-6X16I-R                           | 16' | 3043948 |
|     | TY4ECRC-6X18I-R W/LEDGE LIGHTS ALSO       | 18' | 3160164 |
|     | 6X18I-R                                   | 18' | 1H77863 |

CIRCUIT #1

|         |  |  |  |
|---------|--|--|--|
| LOADING |  |  |  |
| 120V    |  |  |  |
| L1      |  |  |  |
| L2      |  |  |  |

LIGHT CIRCUIT  
26A 27.8W @ 120V

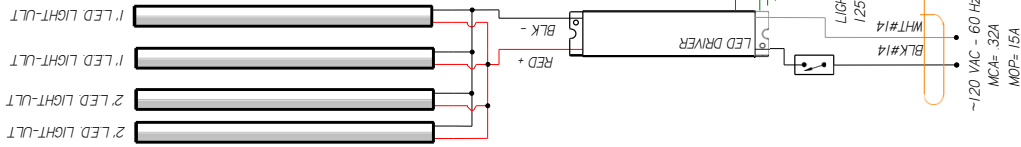

CIRCUIT #2

|         |  |  |  |
|---------|--|--|--|
| LOADING |  |  |  |
| 120     |  |  |  |
| L1      |  |  |  |
| L2      |  |  |  |
| L3      |  |  |  |

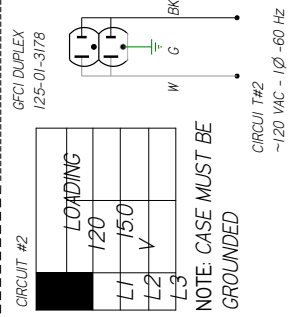

NOTE: CASE MUST BE GROUNDED

CIRCUIT #3

|         |  |  |  |
|---------|--|--|--|
| LOADING |  |  |  |
| 120     |  |  |  |
| L1      |  |  |  |
| L2      |  |  |  |
| L3      |  |  |  |

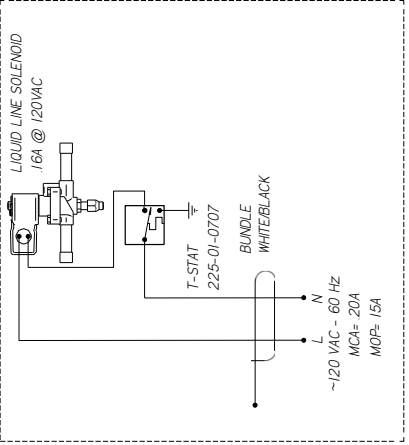

| REV | EN             | DATE       | REVISION DESCRIPTION   | REV BY | CHKD BY | APPR BY |
|-----|----------------|------------|------------------------|--------|---------|---------|
| A   | EDY-CAP-000822 | 2018/01/27 | RELEASED TO PRODUCTION | CB     | CB      | CB      |
| B   | EDY-COD-005276 | 2022/02/17 | NEW LIGHTS             | CB     | CB      | CB      |

OPTIONAL SOLENOID

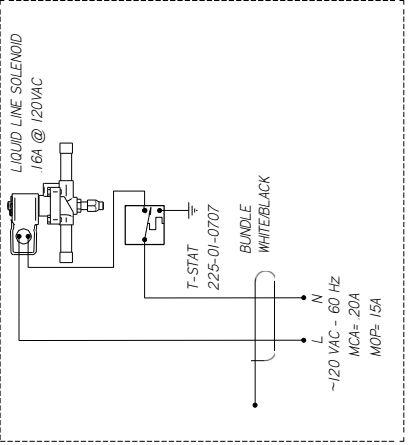

ANTI-SWEAT HEATER  
50W 042A @ 120VAC  
0497590

EVAPORATOR FAN  
12W 0.30A @ 120VAC (6)  
0477655

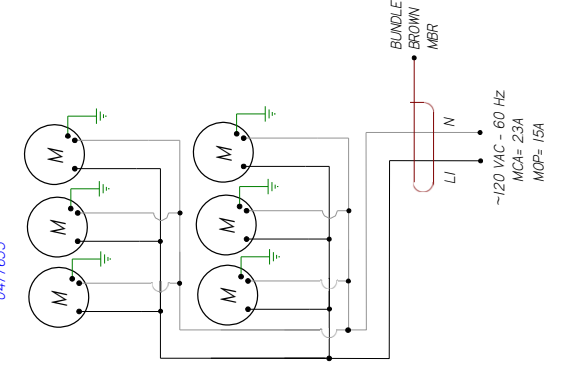

NOTES:  
CASE MUST BE GROUNDED  
WHEN PASSING WIRES THROUGH METAL HOLES A GROMMET MUST BE USED

**HUSSMANN**  
DIAGRAM=1YI-5X71-R

MATERIAL - NA  
DATE DRAWN - 1-17-18  
DRAWN BY - CRAIG ROOREY  
REVIEWED BY - CRAIG ROOREY  
APPROVED BY - CRAIG ROOREY  
UNLESS OTHERWISE SPECIFIED DIMENSIONS ARE IN INCHES  
TOLERANCES ARE:  
THIRD ANGLE PROJECTION  
DECIMALS .XX ±0.3 .XXX ±0.10 ANGLES ± 2°

ECN=CAP-001081Z  
REF -  
SHEET 1 OF 1

3053753 | B

CIRCUIT #1

|         |      |
|---------|------|
| LOADING |      |
| L1      | 120V |
| L2      | 150V |
| L3      |      |

LIGHT CIRCUIT  
26A 278W @ 120V

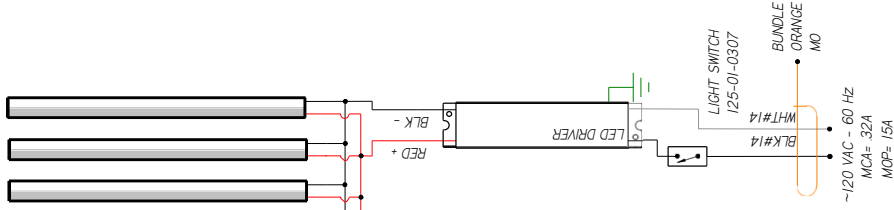
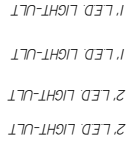

ANTI-SWEAT HEATER  
50W 0.42A @ 120VAC  
0487890

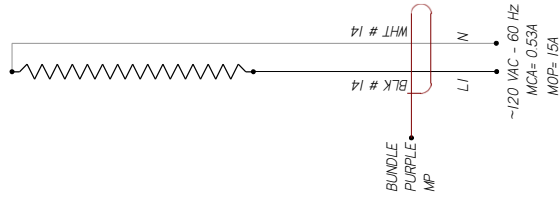

EVAPORATOR FAN  
12W 0.30A @ 120VAC (6)  
0477655

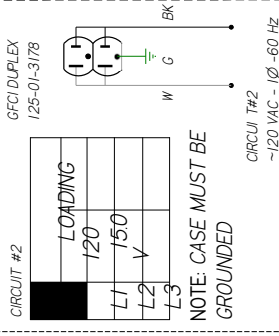
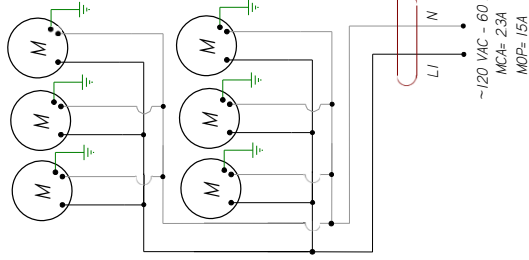

CIRCUIT #2

LOADING

L1 120

L2 150

L3

NOTE: CASE MUST BE GROUNDED

CIRCUIT #2

-120 VAC - 1Ø - 60 Hz

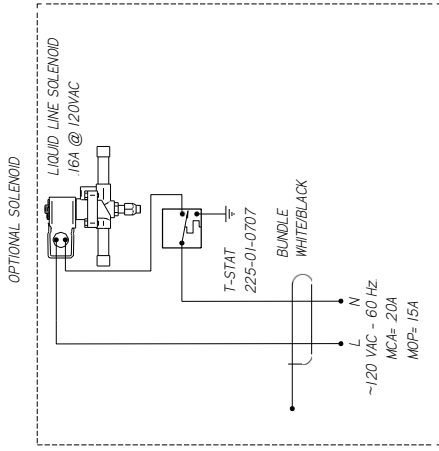

| REV | EN              | DATE       | REVISION DESCRIPTION   | REV BY | CHKD BY | APPR BY |
|-----|-----------------|------------|------------------------|--------|---------|---------|
| A   | ECN-CAP-0002200 | 28/06/2013 | RELEASED TO PRODUCTION | CB     | CB      | CB      |
| B   | ECN-COD-0015276 | 20/02/2017 | NEW LOGOS              | CB     | CB      | CB      |

**HUSSMANN**  
DIAGRAM-IYI-6X8I-R

MATERIAL - NA  
DATE DRAWN - 6-3-16  
DRAWN BY - CRAIG BOOREY  
REVIEWED BY - CRAIG BOOREY  
APPROVED BY - CRAIG BOOREY  
UNLESS OTHERWISE SPECIFIED DIMENSIONS ARE IN INCHES  
TOLERANCES ARE:  
THIRD ANGLE PROJECTION  
DECIMALS .XX ±0.3 .XXX ±0.10 ANGLES ± 2°

ECN-CAP-0002200 REF -  
SHEET 1 OF 1

3008179 | B

NOTES:  
CASE MUST BE GROUNDED  
WHEN PASSING WIRES THROUGH METAL HOLES A GROMMET MUST BE USED

CIRCUIT #1

|         |  |
|---------|--|
| LOADING |  |
| 120V    |  |
| L1      |  |
| L2      |  |
| L3      |  |

LIGHT CIRCUIT  
66A 712W @ 120V

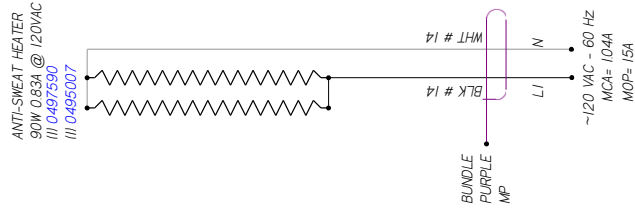
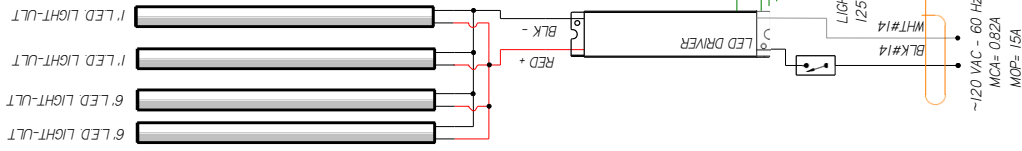

ANTI-SWEAT HEATER  
50W 0.83A @ 120VAC  
I/I 0497590  
I/I 0495007

EVAPORATOR FAN  
12W 0.30A @ 120VAC  
I/I 0477655

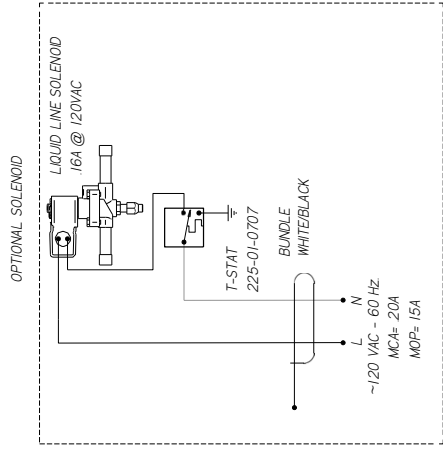
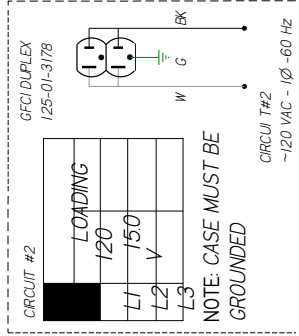
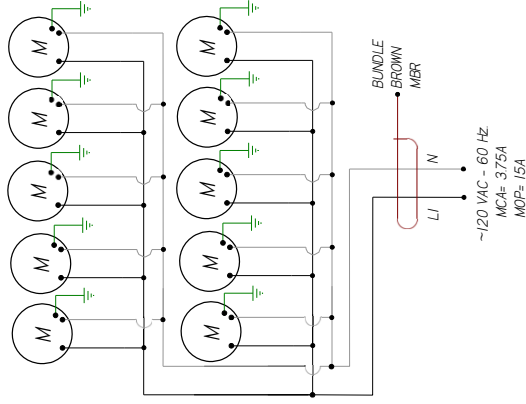

| REV | EN              | DATE     | REVISION DESCRIPTION   | REV BY | CHK BY | APP BY |
|-----|-----------------|----------|------------------------|--------|--------|--------|
| A   | ECN-CAP-0003964 | 20160918 | RELEASED TO PRODUCTION | CB     | CB     | CB     |
| B   | ECN-CAD-0015276 | 20220217 | NEW LOGOS              | CB     | CB     | CB     |

**HUSSMANN**  
DIAGRAM-1Y1-  
6X121-R

MATERIAL - IVA  
DATE DRAWN - 9-8-16  
DRAWN BY - CRAIG BOOREY  
REVIEWED BY - CRAIG BOOREY  
APPROVED BY - CRAIG BOOREY  
SHEET NO. 1  
UNLESS OTHERWISE SPECIFIED DIMENSIONS ARE IN INCHES  
TOLERANCES ARE:  
THIRD ANGL  
E  
PROJECTION

3014692 | B

NOTES:  
CASE MUST BE GROUNDED  
WHEN PASSING WIRES THROUGH METAL HOLES A GROMMET MUST BE USED

CIRCUIT #1

| LOADING | 120V |
|---------|------|
| L1      | 2.63 |
| L2      |      |
| L3      |      |

**NOTE: CASE MUST BE GROUNDED**

EVAPORATOR FAN  
12W 0.30A @ 120VAC  
(6) 0477655

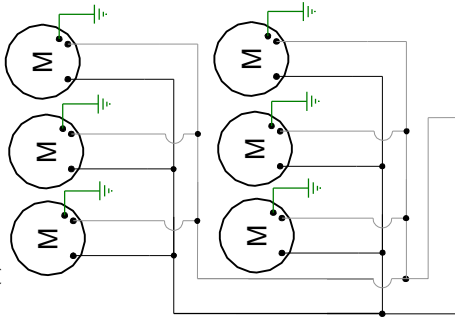

BUNDLE BROWN MBR  
L1 N  
L1 N  
~120 VAC - 50/60 Hz  
MCA= 2.3A  
MOP= 15A

LIGHT CIRCUIT  
0.41A 44.6W@120V

CANOPY LIGHTS

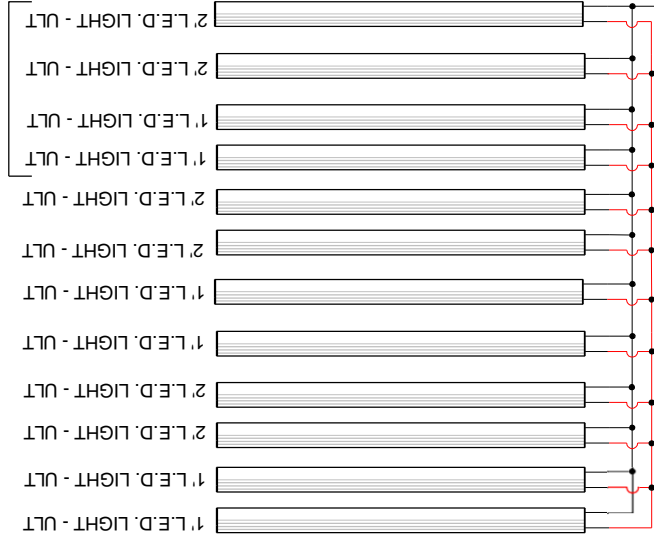

BUNDLE ORANGE MO  
WHT#14  
L1 N  
L1 N  
~120 VAC - 50/60 Hz  
MCA= 0.51  
MOP= 15A

| CIRCUIT #2 | LOADING | 120 V |
|------------|---------|-------|
| L1         | 15.0    |       |
| L2         |         |       |
| L3         |         |       |

**NOTE: CASE MUST BE GROUNDED**

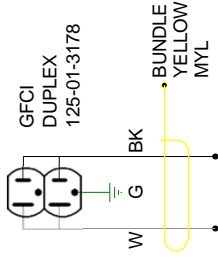

CIRCUIT #2  
~120 VAC - 1Ø - 60 Hz

ANTI-SWEAT HEATER  
50W .42A @ 120 VAC  
0497590

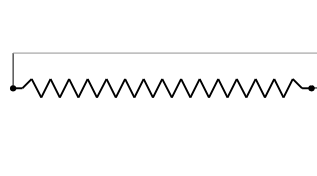

BUNDLE PURPLE MP  
WHT # 14  
L1 N  
L1 N  
~120 VAC - 50/60 Hz  
MCA= 0.46A  
MOP= 15A

OPTIONAL

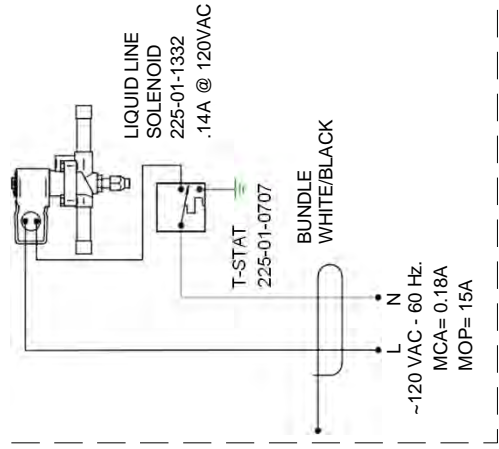

LIQUID LINE SOLENOID  
225-01-1332  
.14A @ 120VAC  
T-STAT  
225-01-0707  
BUNDLE WHITE/BLACK  
L N  
L N  
~120 VAC - 60 Hz.  
MCA= 0.18A  
MOP= 15A

REVISIONS:

| # | DESCRIPTION:                               | DATE:   | BY: |
|---|--|---------|-----|
| A | CN#696786                                  | 3/21/13 | CB  |
| B | CN#980241 CHANGED ANTI-SWEAT HEATER        | 4/15/15 | CB  |
| C | ECN-COD-0015255 NEW LIGHTS; REMOVED DRIVER | 2/28/22 | AL  |

DRAWN BY: CRAIG BOOREY  
CHECKED BY:  
DATE: 3/21/13  
PRODUCTION ORDER #: 936489  
FILE LOCATION:

PROJECT TITLE: TY3-4X6I-R

DRAWING TITLE:

DIAGRAM-TY3-4X6I-R

DRAWING #: 1H85155



| REVISION HISTORY       |                 | REV BY     | CHKD BY | APPR BY |
|------------------------|-----------------|------------|---------|---------|
| 1                      | ECN-CAP-0009958 | 2007/02/23 | CB      | CB      |
| REVISION DESCRIPTION   |                 |            |         |         |
| RELEASED TO PRODUCTION |                 |            |         |         |

| CIRCUIT #1 | LOADING |
|------------|---------|
|            | 120V    |
|            | L1 4.2  |
|            | L2      |
|            | L3      |

| CIRCUIT #2 | LOADING |
|------------|---------|
|            | 120V    |
|            | L1 15.0 |
|            | L2      |
|            | L3      |

NOTE: CASE MUST BE GROUNDED

EVAPORATOR FAN  
12W 0.30A @ 120VAC IBI  
0477655



LED DRIVER  
LED DRIVER

LIGHT SWITCH  
125-01-0307

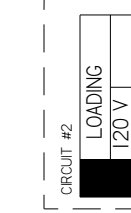
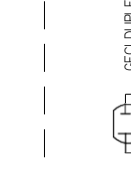

ANTI-SWEAT HEATER@  
120 VAC  
III 0495007 40W 37A  
III 0497590 50W 42A

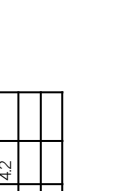
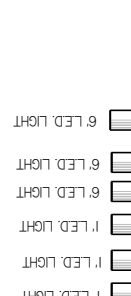
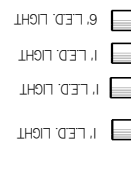

LED DRIVER  
LED DRIVER

LIGHT SWITCH  
125-01-0307

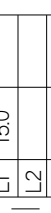
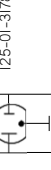

ANTI-SWEAT HEATER@  
120 VAC  
III 0495007 40W 37A  
III 0497590 50W 42A



LED DRIVER  
LED DRIVER

LIGHT SWITCH  
125-01-0307

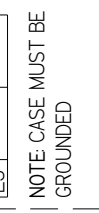
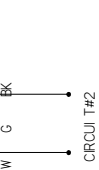

ANTI-SWEAT HEATER@  
120 VAC  
III 0495007 40W 37A  
III 0497590 50W 42A

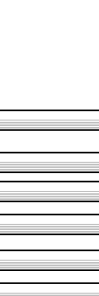
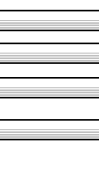

LED DRIVER  
LED DRIVER

LIGHT SWITCH  
125-01-0307

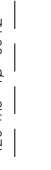

ANTI-SWEAT HEATER@  
120 VAC  
III 0495007 40W 37A  
III 0497590 50W 42A



LED DRIVER  
LED DRIVER

LIGHT SWITCH  
125-01-0307

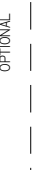

ANTI-SWEAT HEATER@  
120 VAC  
III 0495007 40W 37A  
III 0497590 50W 42A

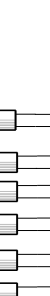

LED DRIVER  
LED DRIVER

LIGHT SWITCH  
125-01-0307

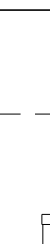

ANTI-SWEAT HEATER@  
120 VAC  
III 0495007 40W 37A  
III 0497590 50W 42A

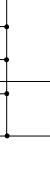

LED DRIVER  
LED DRIVER

LIGHT SWITCH  
125-01-0307

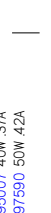

ANTI-SWEAT HEATER@  
120 VAC  
III 0495007 40W 37A  
III 0497590 50W 42A

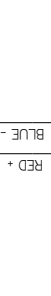
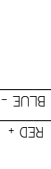

LED DRIVER  
LED DRIVER

LIGHT SWITCH  
125-01-0307

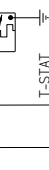
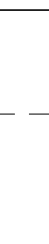

ANTI-SWEAT HEATER@  
120 VAC  
III 0495007 40W 37A  
III 0497590 50W 42A

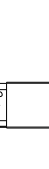

LED DRIVER  
LED DRIVER

LIGHT SWITCH  
125-01-0307

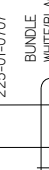

ANTI-SWEAT HEATER@  
120 VAC  
III 0495007 40W 37A  
III 0497590 50W 42A

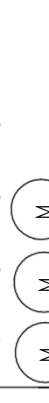
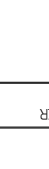

LED DRIVER  
LED DRIVER

LIGHT SWITCH  
125-01-0307

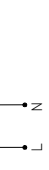
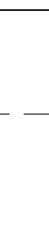

ANTI-SWEAT HEATER@  
120 VAC  
III 0495007 40W 37A  
III 0497590 50W 42A

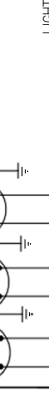

LED DRIVER  
LED DRIVER

LIGHT SWITCH  
125-01-0307

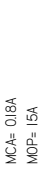

ANTI-SWEAT HEATER@  
120 VAC  
III 0495007 40W 37A  
III 0497590 50W 42A

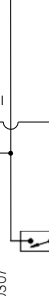
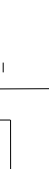

LED DRIVER  
LED DRIVER

LIGHT SWITCH  
125-01-0307

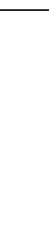

ANTI-SWEAT HEATER@  
120 VAC  
III 0495007 40W 37A  
III 0497590 50W 42A



LED DRIVER  
LED DRIVER

LIGHT SWITCH  
125-01-0307



ANTI-SWEAT HEATER@  
120 VAC  
III 0495007 40W 37A  
III 0497590 50W 42A

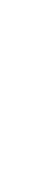

LED DRIVER  
LED DRIVER

LIGHT SWITCH  
125-01-0307

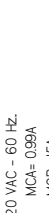

ANTI-SWEAT HEATER@  
120 VAC  
III 0495007 40W 37A  
III 0497590 50W 42A

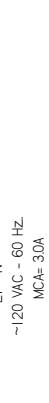

LED DRIVER  
LED DRIVER

LIGHT SWITCH  
125-01-0307

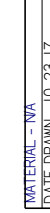

ANTI-SWEAT HEATER@  
120 VAC  
III 0495007 40W 37A  
III 0497590 50W 42A

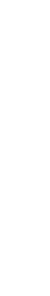

LED DRIVER  
LED DRIVER

LIGHT SWITCH  
125-01-0307



ANTI-SWEAT HEATER@  
120 VAC  
III 0495007 40W 37A  
III 0497590 50W 42A



LED DRIVER  
LED DRIVER

LIGHT SWITCH  
125-01-0307



ANTI-SWEAT HEATER@  
120 VAC  
III 0495007 40W 37A  
III 0497590 50W 42A



LED DRIVER  
LED DRIVER

LIGHT SWITCH  
125-01-0307



ANTI-SWEAT HEATER@  
120 VAC  
III 0495007 40W 37A  
III 0497590 50W 42A



LED DRIVER  
LED DRIVER

LIGHT SWITCH  
125-01-0307



ANTI-SWEAT HEATER@  
120 VAC  
III 0495007 40W 37A  
III 0497590 50W 42A



LED DRIVER  
LED DRIVER

LIGHT SWITCH  
125-01-0307



ANTI-SWEAT HEATER@  
120 VAC  
III 0495007 40W 37A  
III 0497590 50W 42A



| REVISION HISTORY |                 | REVISION DESCRIPTION |                        | REV BY |    | CHK BY |    | APP BY |    |
|------------------|-----------------|----------------------|------------------------|--------|----|--------|----|--------|----|
| REV              | EN              | DATE                 | DESCRIPTION            | CB     | CE | CB     | CE | CB     | CE |
| A                | ECN-CAP-0002200 | 2016/06/03           | RELEASED TO PRODUCTION |        |    |        |    |        |    |
| B                | ECN-COD-0016255 | 2022/02/28           | NEW LIGHTS             |        |    |        |    |        |    |

| CIRCUIT #1 | LOADING |
|------------|---------|
| L1         | 120V    |
| L2         | 150     |
| L3         |         |

NOTE: CASE MUST BE GROUNDED

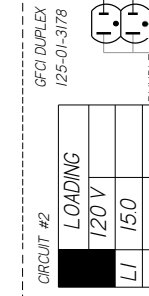

CIRCUIT T#2  
~120 VAC - 1Ø - 60 Hz

| CIRCUIT #2 | LOADING |
|------------|---------|
| L1         | 120V    |
| L2         | 150     |
| L3         |         |

NOTE: CASE MUST BE GROUNDED

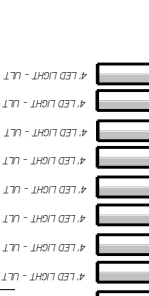

CIRCUIT T#2  
~120 VAC - 1Ø - 60 Hz

ANTI-SWEAT HEATERS  
60W 55A @ 120 VAC  
III 0495008  
50W 46A @ 120 VAC  
III 0497590

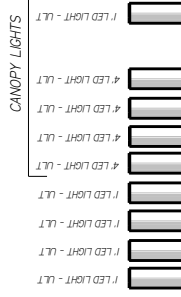

~120 VAC - 60 Hz  
MCA= 126A  
MOP= 15A

TOGGLE SWITCH  
125-01-0307



~120 VAC - 60 Hz  
MCA= 156A  
MOP= 15A

LED DRIVER

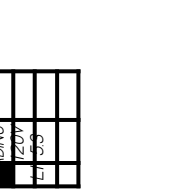

~120 VAC - 60 Hz  
MCA= 156A  
MOP= 15A

CANOPY LIGHTS



~120 VAC - 60 Hz  
MCA= 156A  
MOP= 15A

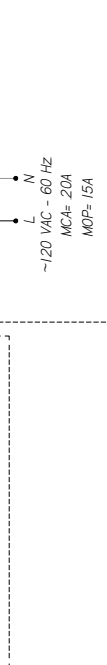

OPTIONAL SOLENOID  
LIQUID LINE SOLENOID  
.16A @ 120VAC

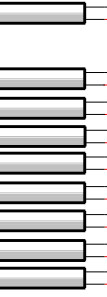

EVAPORATOR FANS  
12W 0.3A @ 120VAC  
III 0477655



~120 VAC - 60 Hz  
MCA= 38A  
MOP= 15A

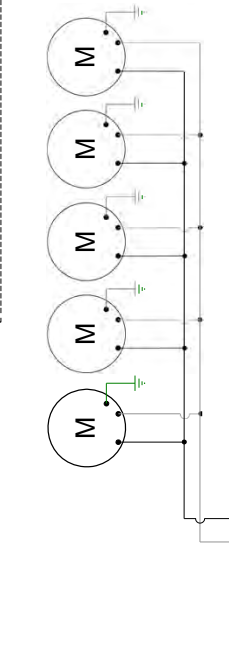

EVAPORATOR FANS  
12W 0.3A @ 120VAC  
III 0477655

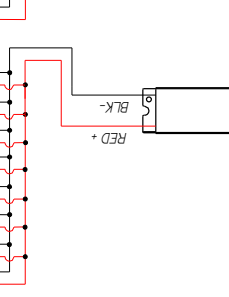

EVAPORATOR FANS  
12W 0.3A @ 120VAC  
III 0477655

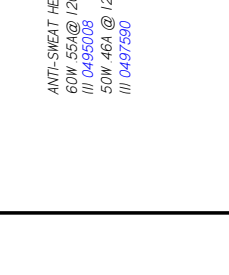

~120 VAC - 60 Hz  
MCA= 38A  
MOP= 15A

**HUSMANN**  
DIAGRAM-1Y3-  
4X12I-R

DATE DRAWN - 6-3-16  
DRAWN BY - CRAIG BOOREY  
REVIEWED BY - CRAIG BOOREY  
APPROVED BY - CRAIG BOOREY  
UNLESS OTHERWISE SPECIFIED DIMENSIONS ARE IN INCHES  
TOLERANCES ARE:  
THIRD ANGLE PROJECTION  
DECIMALS .XX ±0.03 .XXX ±0.10 ANGLES ± 2°

MATERIAL - NA  
ECN-CAP-0002200  
REF -  
SHEET 1 OF 1

3008178 | B



NOTES:  
CASE MUST BE GROUNDED  
WHEN PASSING WIRES THROUGH METAL HOLES A GROMMET MUST BE USED

| CIRCUIT #1 | LOADING | 120V | 150V |
|------------|---------|------|------|
|            |         |      |      |

| REVISION HISTORY |     | DATE       | DESCRIPTION                 | REV. BY | CHKD BY | APPR BY |
|------------------|-----|------------|-----------------------------|---------|---------|---------|
| 1                | ECN | 2016/06/03 | RELEASED TO PRODUCTION      | CB      | CB      | CB      |
| 2                | ECN | 2022/02/28 | NEW LIGHTS & REMOVED DRIVER | AL      | CB      | CB      |

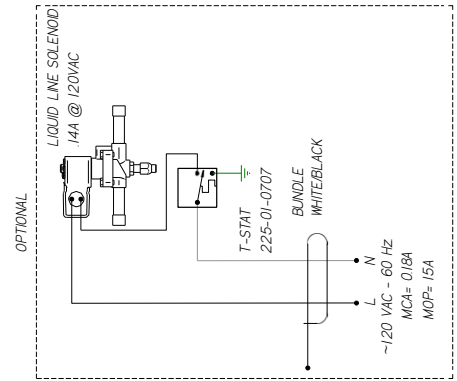
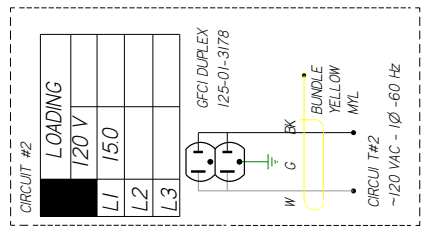
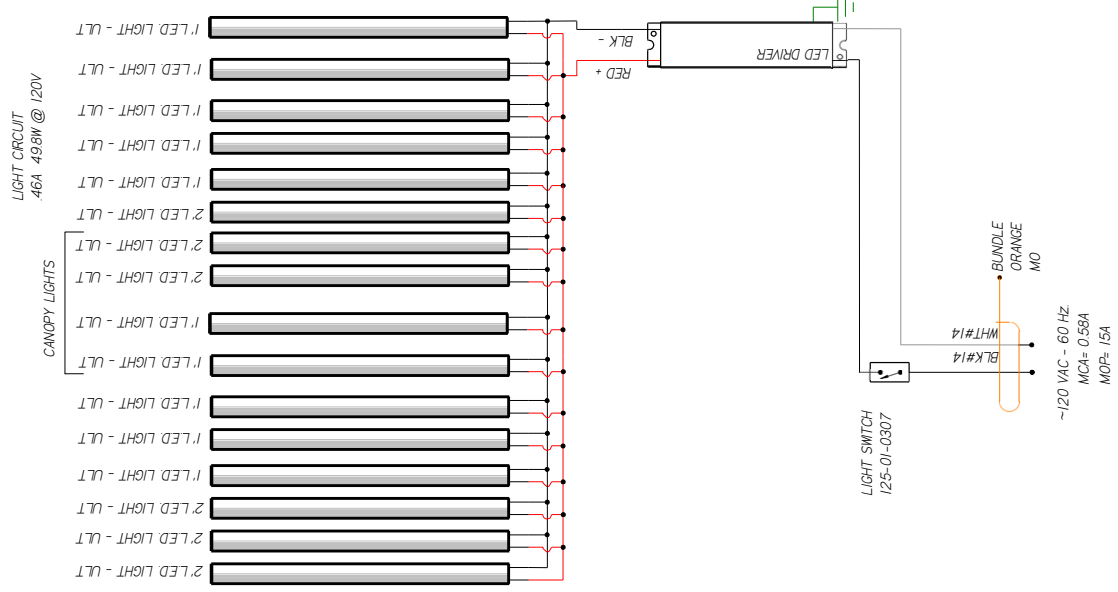

NOTES:  
CASE MUST BE GROUNDED  
WHEN PASSING WIRES THROUGH METAL HOLES A GROMMET MUST BE USED

**MATERIAL - N/A**

DATE DRAWN - 6-3-16  
DRAWN BY - CRAIG BOOREY  
REVIEWED BY - CRAIG BOOREY  
APPROVED BY - CRAIG BOOREY

ECN-CAP-0002200  
REF -  
SHEET NO. 1  
UNLESS OTHERWISE SPECIFIED DIMENSIONS ARE IN INCHES  
TOLERANCES ARE:  
THIRD ANGLE PROJECTION

**HUSSMANN**  
**DIAGRAM-IY3-**  
**5X7I-R**

DECIMALS .XX ±0.3 .XXX ±0.0

**3008177** | **B**

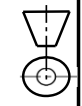



CIRCUIT #1

| CIRCUIT #2 | LOADING |
|------------|---------|
|            | 120 V   |
| L1         | 15.0    |
| L2         |         |
| L3         |         |

**NOTE: CASE MUST BE GROUNDED**

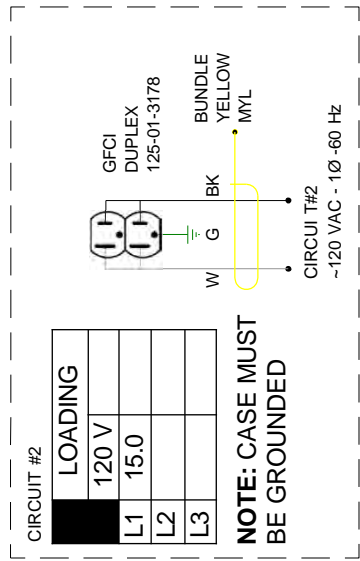

| CIRCUIT #1 | LOADING |
|------------|---------|
|            | 120 V   |
| L1         | 4.92    |
| L2         |         |
| L3         |         |

**NOTE: CASE MUST BE GROUNDED**

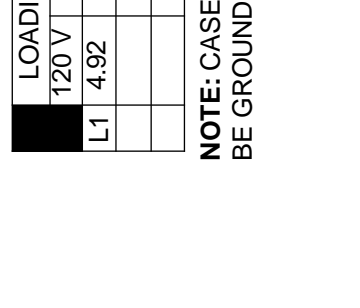

CANOPY LIGHTS

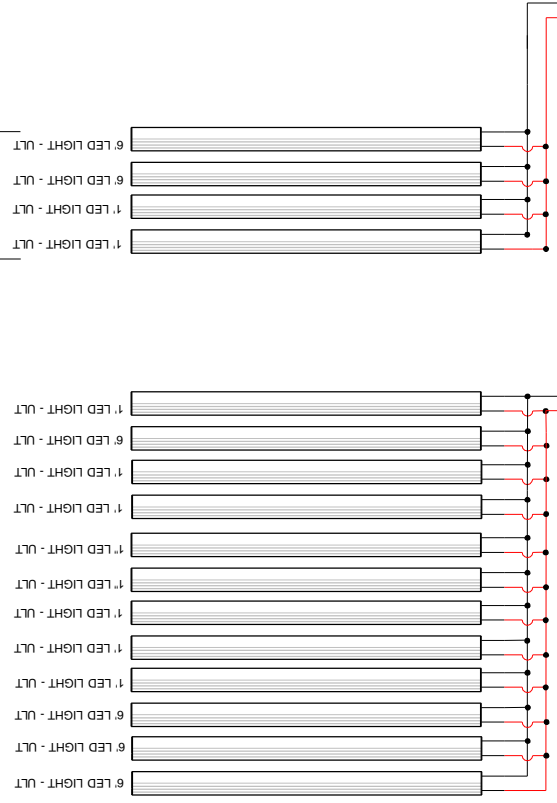

ANTI-SWEAT HEATER  
40W .37A @ 120 VAC  
0495007

ANTI-SWEAT HEATER  
50W .46A @ 120 VAC  
0497590

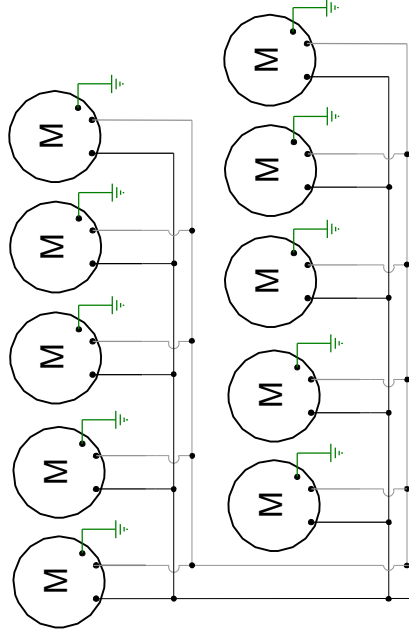
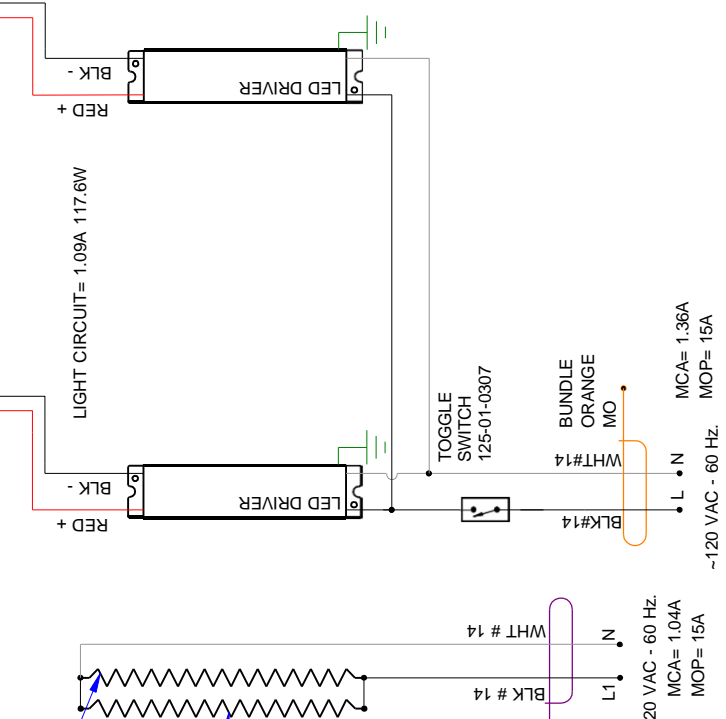

EVAPORATOR FANS  
12W 0.3A @ 120VAC  
(10) 0477655

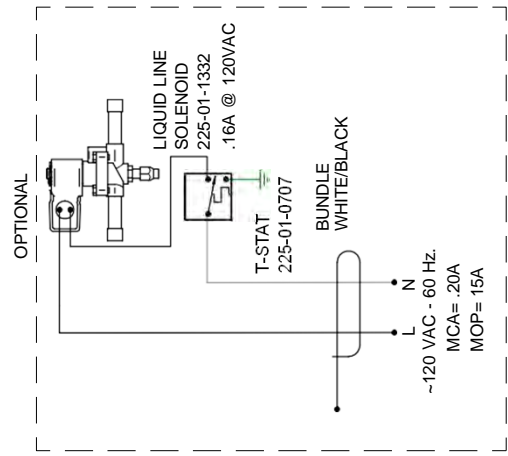

REVISIONS:

| # | DESCRIPTION:               |
|---|----------------------------|
| A | CN#720718                  |
| B | ECN-COD-0015255 NEW LIGHTS |

|       |         |
|-------|---------|
| DATE: | 5/6/13  |
| BY:   | CB      |
| DATE: | 2/22/22 |
| BY:   | AL      |

|                |                     |
|----------------|---------------------|
| PROJECT TITLE: | TY3-CASE            |
| DRAWING TITLE: | DIAGRAM-TY3-5X111-R |

|                     |              |
|---------------------|--------------|
| DRAWN BY:           | CRAIG BOOREY |
| CHECKED BY:         |              |
| DATE:               | 5/6/13       |
| DATE:               | 5/6/13       |
| PRODUCTION ORDER #: |              |
| FILE LOCATION:      |              |

DRAWING #: 1H86614





CANOPY LIGHTS

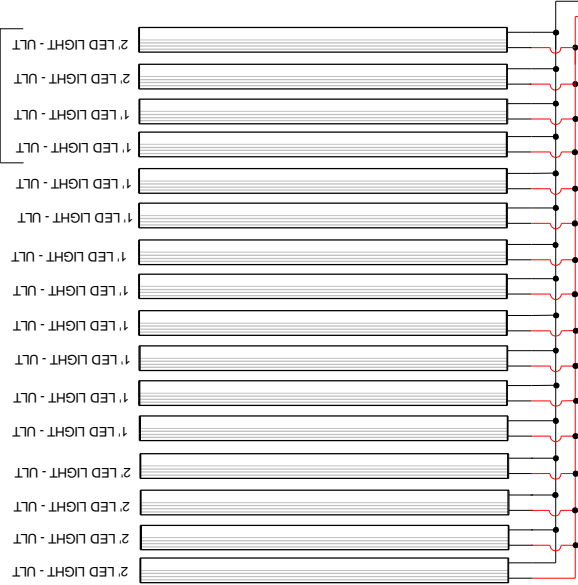

ANTI-SWEAT HEATER  
50W .42A @ 120 VAC  
0497590

LIGHT CIRCUIT= 0.46A 49.8W

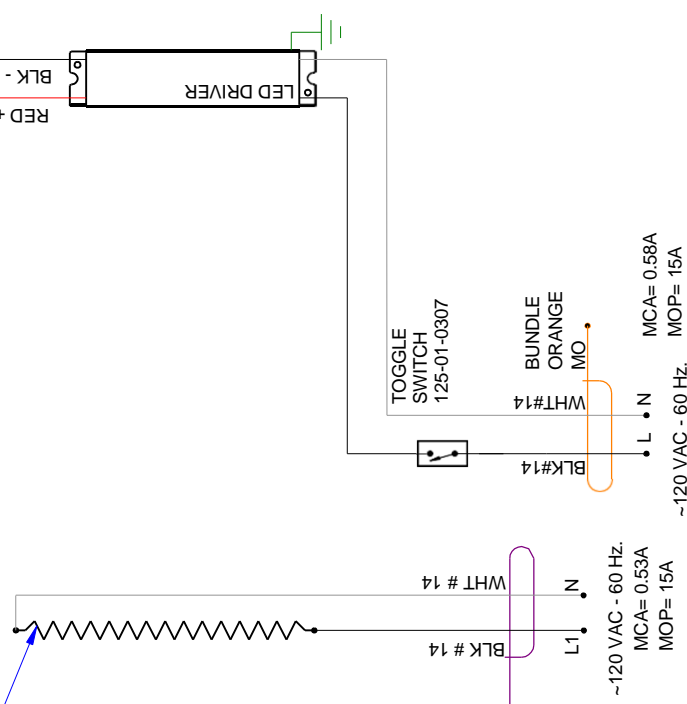

~120 VAC - 60 Hz.  
MCA= 0.53A  
MOP= 15A

~120 VAC - 60 Hz.  
MCA= 0.58A  
MOP= 15A

CIRCUIT #1

| LOADING |     |
|---------|-----|
| 120 V   |     |
| L1      | 2.7 |
|         |     |
|         |     |

**NOTE: CASE MUST BE GROUNDED**

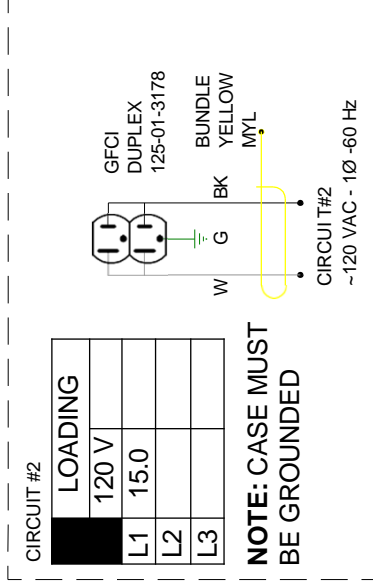

| LOADING |      |
|---------|------|
| 120 V   |      |
| L1      | 15.0 |
| L2      |      |
| L3      |      |

**NOTE: CASE MUST BE GROUNDED**

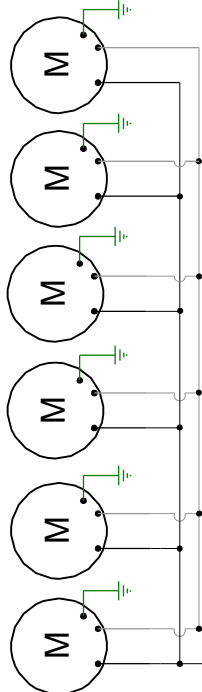

EVAPORATOR FANS  
12W 0.3A @ 120VAC  
(6) 0477655

BUNDLE BROWN MBR  
BLK#14  
WHT#14  
L  
N  
~120 VAC - 60 Hz.  
MCA= 2.25A  
MOP= 15A

OPTIONAL

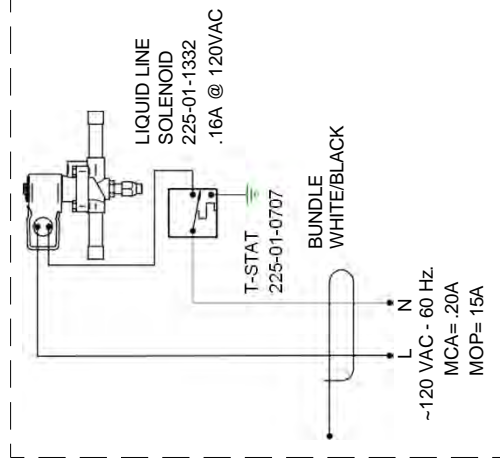

LIQUID LINE SOLENOID  
225-01-1332  
.16A @ 120VAC  
T-STAT  
225-01-0707  
BUNDLE WHITE/BLACK  
L  
N  
~120 VAC - 60 Hz.  
MCA= .20A  
MOP= 15A

REVISIONS:

| # | DESCRIPTION:               |
|---|----------------------------|
| A | CN# 720718                 |
| B | ECN-COD-0015255 NEW LIGHTS |

| DATE:   | BY: |
|---------|-----|
| 5/6/13  | CB  |
| 2/28/22 | AL  |

| FILE LOCATION: |
|----------------|
| NEW LIGHTS     |

| PRODUCTION ORDER #: |
|---------------------|
| 0015255             |

| PROJECT TITLE: |
|----------------|
| TY3-CASE       |

| DRAWING TITLE:     |
|--------------------|
| DIAGRAM-TY3-6X81-R |

| DRAWING #: |
|------------|
| 1H86612    |

| REVISION HISTORY |                 |            |                           |
|------------------|-----------------|------------|---------------------------|
| REV              | EN              | DATE       | DESCRIPTION               |
| A                | ECN-CAP-0003968 | 2016/01/13 | RELEASED TO PRODUCTION    |
| B                | ECN-CAP-0014946 | 2018/01/13 | REVISED ANTI-SWEAT HEATER |

| CIRCUIT #1 | LOADING | 120V | 150V | 180V |
|------------|---------|------|------|------|
|            |         |      |      |      |

| CIRCUIT #2 | LOADING | 120 V | 150 | 180 |
|------------|---------|-------|-----|-----|
| L1         |         |       |     |     |
| L2         |         |       |     |     |
| L3         |         |       |     |     |

NOTE: CASE MUST BE GROUNDED

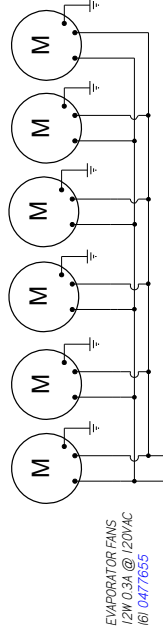
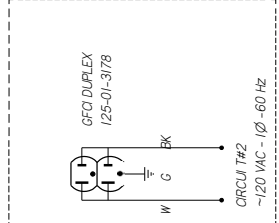

EVAPORATOR FANS  
1/2W 0.3A @ 120VAC  
161 0477655

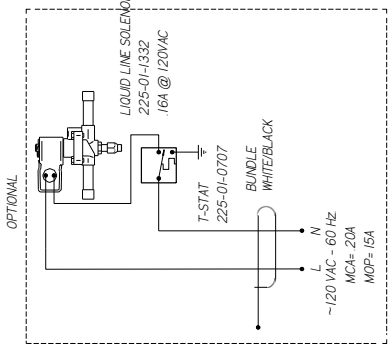

OPTIONAL

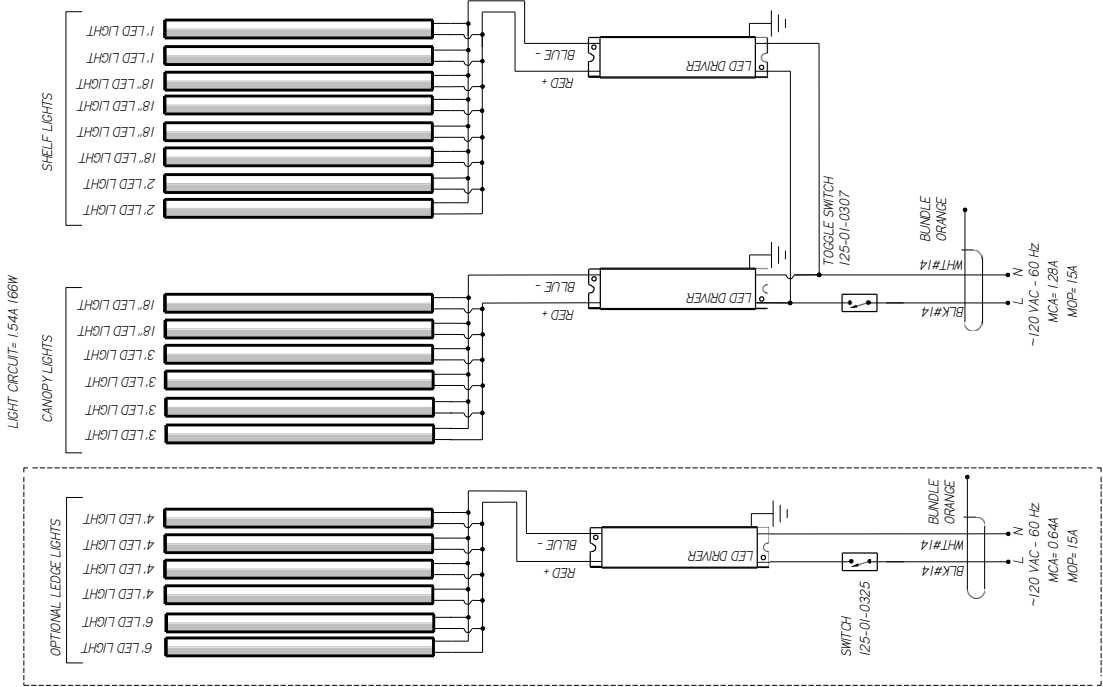

LIGHT CIRCUIT= 1.544/168W

ANTI-SWEAT HEATER  
60W 50A @ 120 VAC  
0495008

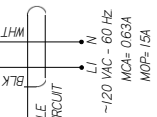

TAG PURPLE HEATER CIRCUIT

**HUSSMANN**  
DIAGRAM-  
TY3ECSQ- 6X81-R

MATERIAL - NA  
DATE DRAWN - 10-13-16  
DRAWN BY - CRAIG BOOREY  
REVIEWED BY - CRAIG BOOREY  
APPROVED BY - CRAIG BOOREY  
UNLESS OTHERWISE SPECIFIED DIMENSIONS ARE IN INCHES  
TOLERANCES ARE:  
DECIMALS .XX ±0.3 .XXX  
±0.0

ECN-CAP-0003968 REF -  
SHEET 1 OF 1  
THIRD ANGLE PROJECTION

301718 | B

NOTES:  
CASE MUST BE GROUNDED  
WHEN PASSING WIRES THROUGH METAL HOLES A GROMMET MUST BE USED



CIRCUIT #1

| LOADING |      |
|---------|------|
| 120 V   |      |
| L1      | 3.75 |
|         |      |
|         |      |

**NOTE: CASE MUST BE GROUNDED**

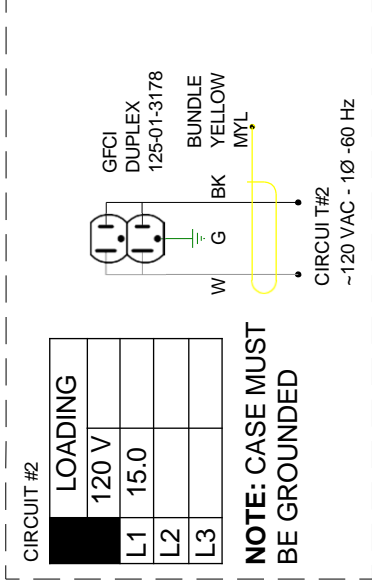

ANTI-SWEAT HEATER  
120 VAC  
(1) 0495007 40W, .33A  
(1) 0495006 30W, .25A

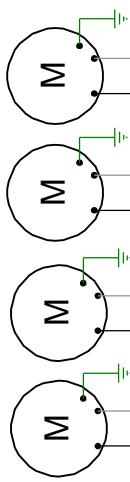

EVAPORATOR FANS  
PER COIL  
12W 0.3A @ 120VAC  
(4) 0477655

~120 VAC - 60 Hz.  
MCA= 1.5A  
MOP= 15A

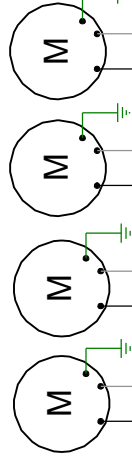

EVAPORATOR FANS  
PER COIL  
12W 0.3A @ 120VAC  
(4) 0477655

~120 VAC - 60 Hz.  
MCA= 1.5A  
MOP= 15A

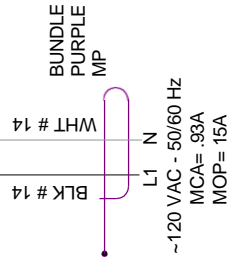

~120 VAC - 50/60 Hz  
MCA= .93A  
MOP= 15A

CANOPY LIGHTS

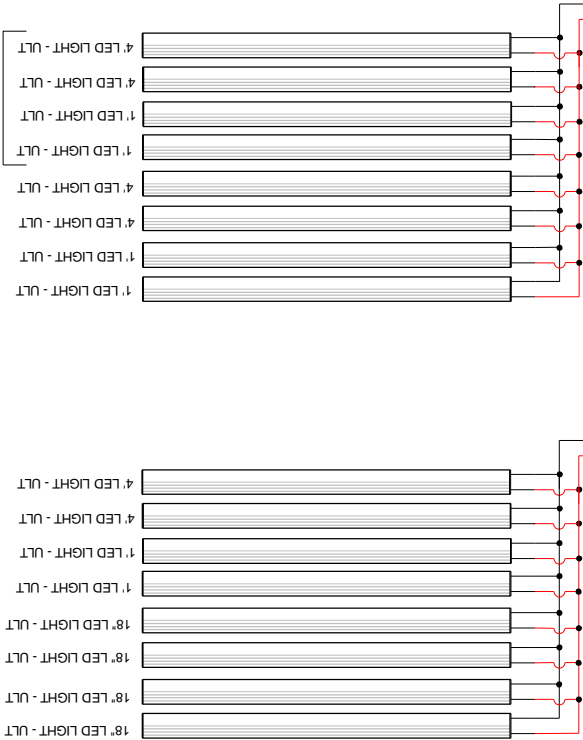

OPTIONAL

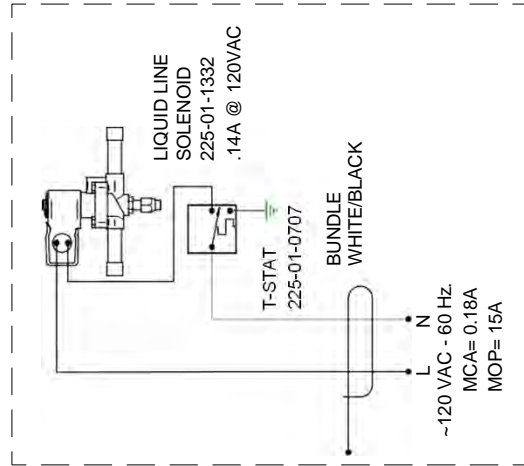

LIGHT CIRCUIT= 0.77A 83.6W

~120 VAC - 60 Hz.  
MCA= 0.96A  
MOP= 15A

| REVISION HISTORY       |                 | DATE       | REV BY | CHKD BY | APPR BY |
|------------------------|-----------------|------------|--------|---------|---------|
| 1                      | ECN-CAP-0009958 | 2017/02/20 | CB     | CB      | CB      |
| RELEASED TO PRODUCTION |                 |            |        |         |         |

| CIRCUIT #1 | LOADING |
|------------|---------|
| L1         | 120V    |
| L2         | 149     |
| L3         |         |

9.3A 100.3W @ 120V

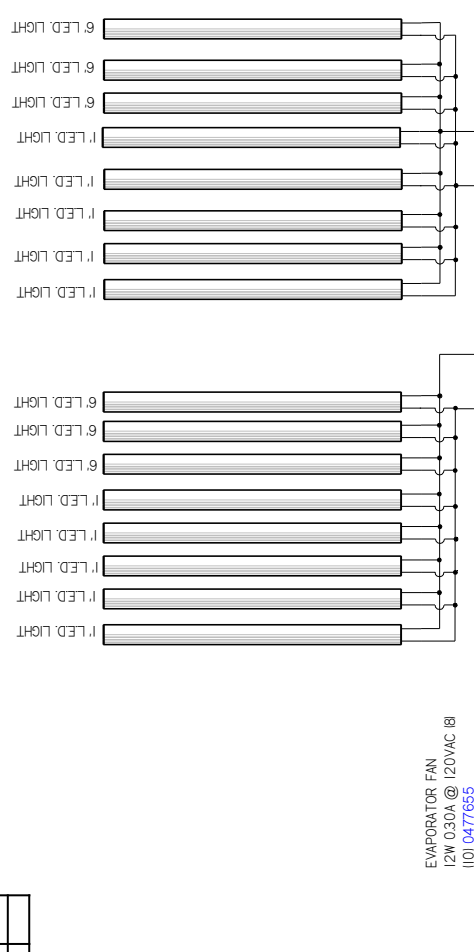

EVAPORATOR FAN  
12W 0.30A @ 120VAC (I)  
1101 0477655

LED DRIVER  
LED DRIVER  
LED DRIVER

LED DRIVER  
LED DRIVER

LED DRIVER  
LED DRIVER

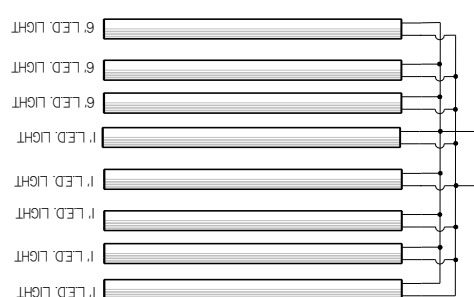

9.3A 100.3W @ 120V

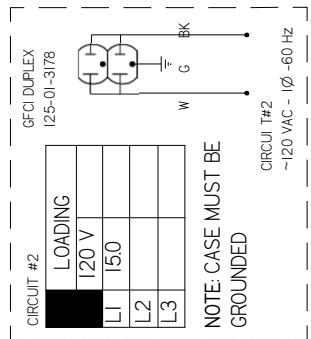

CIRCUIT #2  
-120 VAC - 60 Hz

GFCI DUPLEX  
125-01-3178

ANTI-SWEAT HEATER  
40W 37A @ 120 VAC  
0495007  
50W 46A @ 120 VAC  
0497590

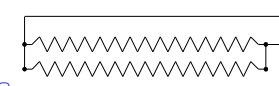

BUNDLE  
PURPLE

-120 VAC - 60 Hz  
MCA= 104A  
MOP= 15A

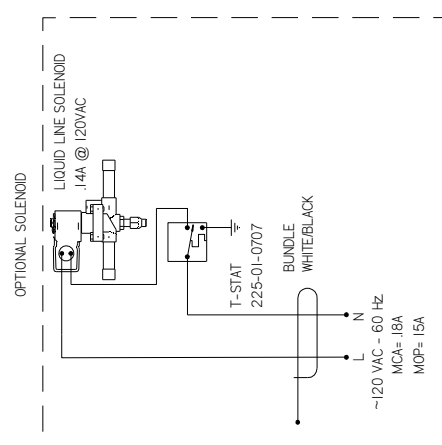

OPTIONAL SOLENOID

LIQUID LINE SOLENOID  
.14A @ 120VAC

T-STAT  
225-01-0707

BUNDLE  
WHITE/BLACK

-120 VAC - 60 Hz  
MCA= 18A  
MOP= 15A

**HUSSMANN**  
DIAGRAM=TY3-6X1Z-

MATERIAL - NA  
DATE DRAWN - 10-20-17  
DRAWN BY - CRAIG BOOREY  
REVIEWED BY - CRAIG BOOREY  
APPROVED BY - CRAIG BOOREY  
UNLESS OTHERWISE SPECIFIED DIMENSIONS ARE IN INCHES  
TOLERANCES ARE:  
DECIMALS .XX ±0.3 .XXX ±0.10  
ANGLES ± 2°

ECN-CAP-0009958  
REF -  
SHEET 1 OF 1  
THIRD PRODUCTION

3047528 A

NOTES:  
CASE MUST BE GROUNDED  
WHEN PASSING WIRES THROUGH METAL HOLES A GROMMET MUST BE USED

| REVISION HISTORY |                 | REV       | BY | DATE | REVISION DESCRIPTION   | REV BY | CHKD BY | APPR BY |
|------------------|-----------------|-----------|----|------|------------------------|--------|---------|---------|
| 1                | ECN-CAP-0009960 | 2007/10/2 | CB | CB   | RELEASED TO PRODUCTION | CB     | CB      | CB      |

| CIRCUIT #1 |      |
|------------|------|
| LOADING    | 120V |
| L1         | 7.6  |
| L2         |      |
| L3         |      |

| CIRCUIT #2 |      |
|------------|------|
| LOADING    | 120V |
| L1         | 15.0 |
| L2         |      |
| L3         |      |

NOTE: CASE MUST BE GROUNDED

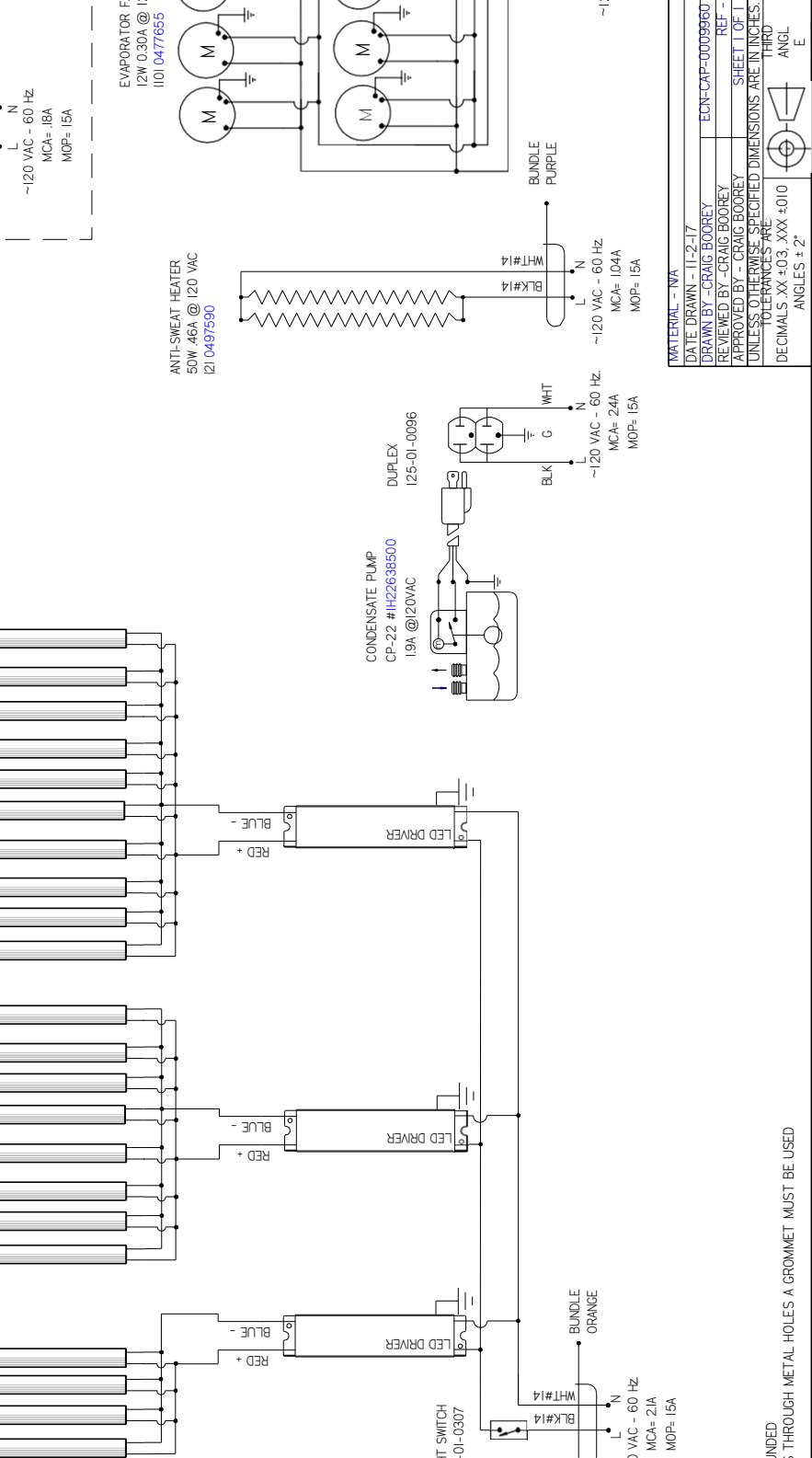
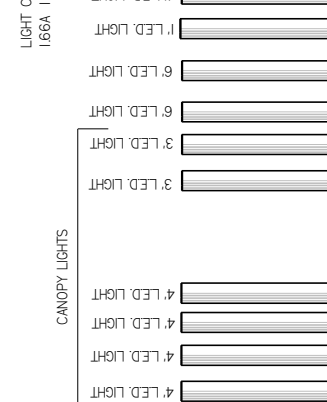
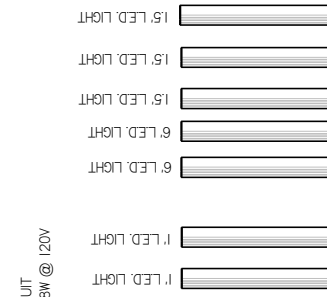
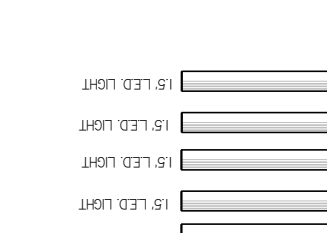

**Hussmann**  
DIAGRAM=1Y3ECSQ-6X12-R

|   |                        |
|---|------------------------|
| MATERIAL - NA                                       | DATE DRAWN - 11-2-17   |
| DRAWN BY - CRAIG BOOREY                             | ECN-CAP-0009960        |
| REVIEWED BY - CRAIG BOOREY                          | REF -                  |
| APPROVED BY - CRAIG BOOREY                          | SHEET 1 OF 1           |
| UNLESS OTHERWISE SPECIFIED DIMENSIONS ARE IN INCHES | THIRD ANGLE PROJECTION |
| TOLERANCES ARE:                                     |                        |
| DECIMALS .XX ±0.3 .XXX ±0.10                        |                        |
| ANGLES ± 2°   |                        |

3048459

A

NOTES:  
CASE MUST BE GROUNDED  
WHEN PASSING WIRES THROUGH METAL HOLES A GROMMET MUST BE USED

CIRCUIT #1

| LOADING |     |
|---------|-----|
| 120 V   |     |
| L1      | 5.8 |
|         |     |
|         |     |

**NOTE: CASE MUST BE GROUNDED**

CANOPY LIGHTS

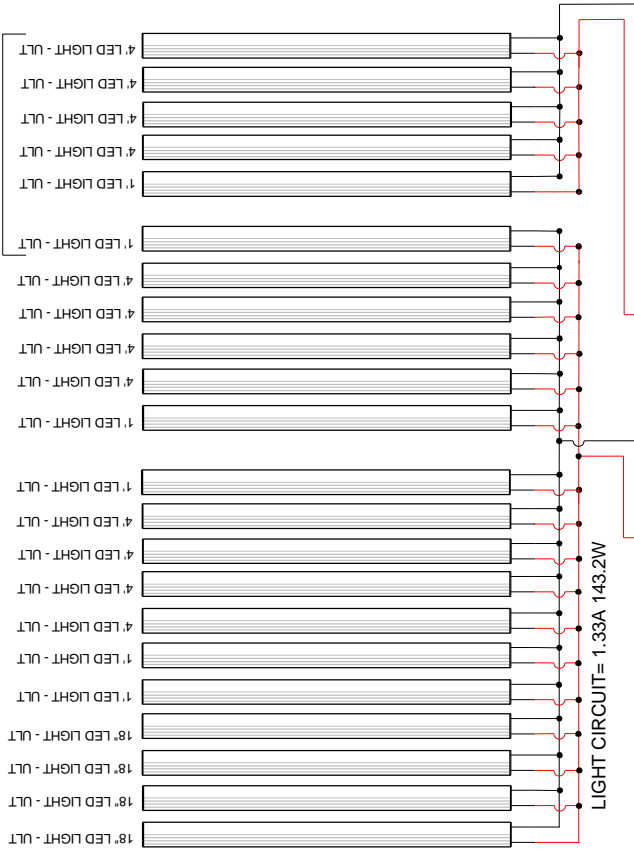

ANTI-SWEAT HEATER  
60W .50A @ 120 VAC  
0495008

ANTI-SWEAT HEATER  
50W .42A @ 120 VAC  
0497590

LIGHT CIRCUIT= 1.33A 143.2W

LED DRIVER

LED DRIVER

LIGHT SWITCH  
125-01-0311

BUNDLE PURPLE MP

BUNDLE ORANGE MO

WHT #14

BLK #14

L N

MCA= 1.15A  
MOP= 15A

~120 VAC - 60 HZ.

MCA= 1.66A  
MOP= 15A

~120 VAC - 60 HZ.

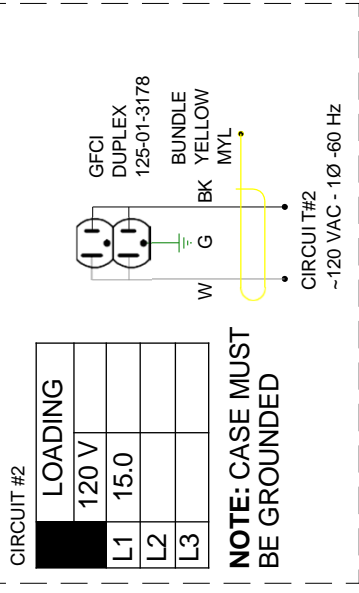

| LOADING |      |
|---------|------|
| 120 V   |      |
| L1      | 15.0 |
| L2      |      |
| L3      |      |

**NOTE: CASE MUST BE GROUNDED**

CIRCUIT #2  
~120 VAC - 1Ø -60 HZ

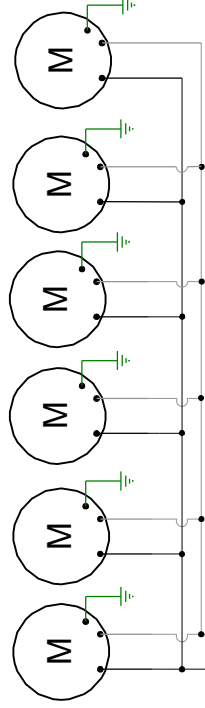

EVAPORATOR FANS  
PER COIL  
12W 0.3A @ 120VAC  
(6) 0477655

WHT #14

BLK #14

L N

MCA= 2.3A  
MOP= 15A

~120 VAC - 60 HZ.

OPTIONAL

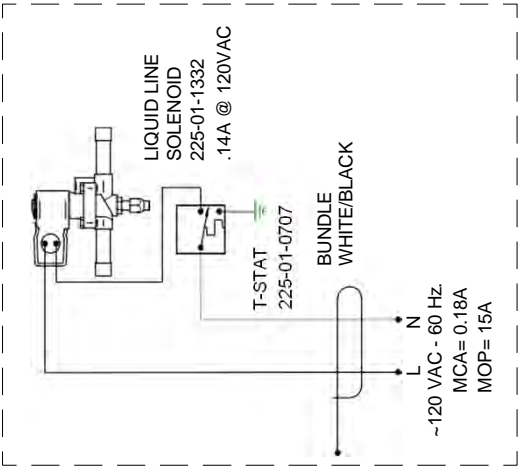

EVAPORATOR FANS  
PER COIL  
12W 0.3A @ 120VAC  
(6) 0477655

WHT #14

BLK #14

L N

MCA= 2.3A  
MOP= 15A

~120 VAC - 60 HZ.

REVISIONS:

| # | DESCRIPTION:                        |
|---|-------------------------------------|
| A | CN#634531                           |
| B | CN#696786 Added AS Htrs. & Solenoid |
| C | ECN-COD-0015255 NEW LIGHTS          |

| DATE:   | BY: |
|---------|-----|
| 8/7/12  | CB  |
| 3/21/13 | CB  |
| 2/28/22 | AL  |

| DRAWN BY:           | CRAIG BOOREY |
|---------------------|--------------|
| CHECKED BY:         | DATE: 8/8/12 |
| PRODUCTION ORDER #: | 920172       |
| FILE LOCATION:      |              |

| PROJECT TITLE: | TY3-ISLAND CASE     |
|----------------|---------------------|
| DRAWING TITLE: | DIAGRAM-TY3-6X141-R |

| REVISION HISTORY |                | REV. BY | CHKD BY  | APPR BY                |
|------------------|----------------|---------|----------|------------------------|
| 1                | LEO-CAP-001188 | DATE    | 20080205 | RELEASED TO PRODUCTION |
| 2                |                |         |          |                        |

| LOADING | 120V | 150V | 180V |
|---------|------|------|------|
| L1      |      |      |      |
| L2      |      |      |      |
| L3      |      |      |      |

CIRCUIT #2  
NOTE: CASE MUST BE GROUNDED



CIRCUIT #2  
~120 VAC - 1Ø - 60 Hz

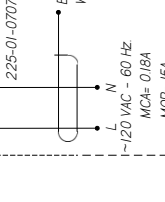
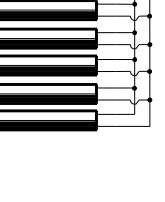
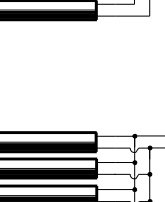
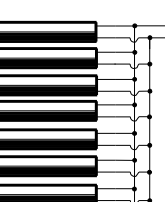
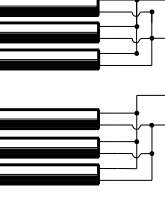
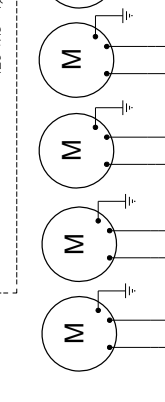
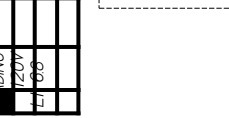
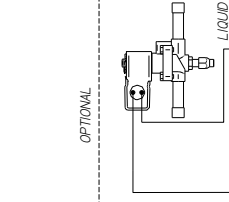
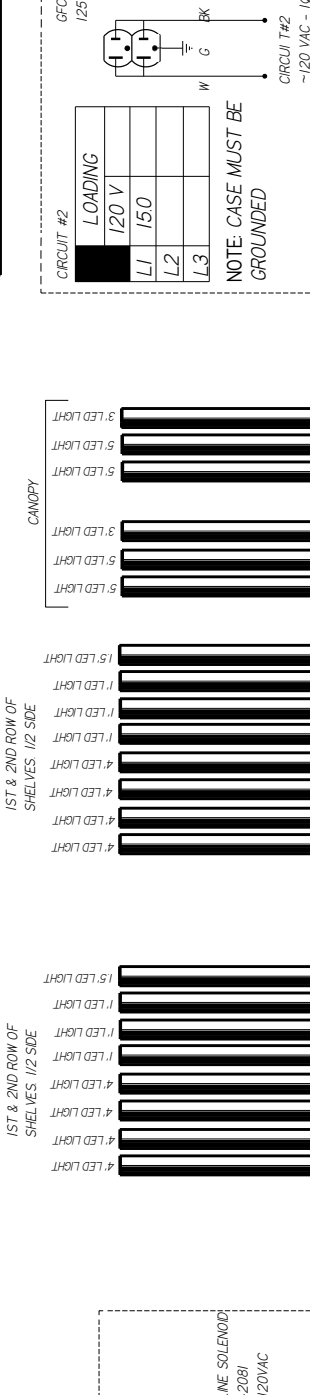

|                            |  |                                |  |
|----------------------------|--|--------------------------------|--|
| DATE DRAWN - 2-5-18        |  | ECON-CAP-001188                |  |
| DRAWN BY - CRAIG BOOREY    |  | REF -                          |  |
| REVIEWED BY - CRAIG BOOREY |  | SHEET NO. 1                    |  |
| APPROVED BY - CRAIG BOOREY |  | DIMENSIONS ARE IN INCHES       |  |
| UNLESS OTHERWISE SPECIFIED |  | TOLERANCES ARE:                |  |
|                            |  | FRACTIONS - ±0.005             |  |
|                            |  | DECIMALS - XX ±0.03, XXX ±0.01 |  |
|                            |  | ANGLES ± 2°                    |  |

**HUSSMANN**  
DIAGRAM-  
TY3ECRC- 6X141-R

3055337 | A  
PROJECTION



NOTES:  
CASE MUST BE GROUNDED  
WHEN PASSING WIRES THROUGH METAL HOLES A GROMMET MUST BE USED



| REVISION HISTORY       |                | REV. BY  | CHG. BY | APPR. BY |
|------------------------|----------------|----------|---------|----------|
| 1                      | LEO-CAP-001087 | 20080403 | CB      | CB       |
| RELEASED TO PRODUCTION |                |          |         |          |

| CIRCUIT #1 | LOADING |
|------------|---------|
|            | 120V    |
|            | 150V    |
|            | 180V    |

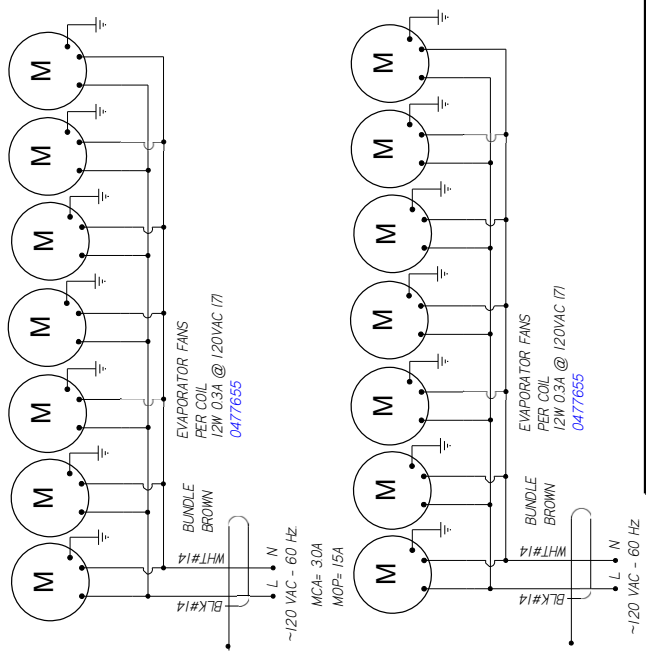
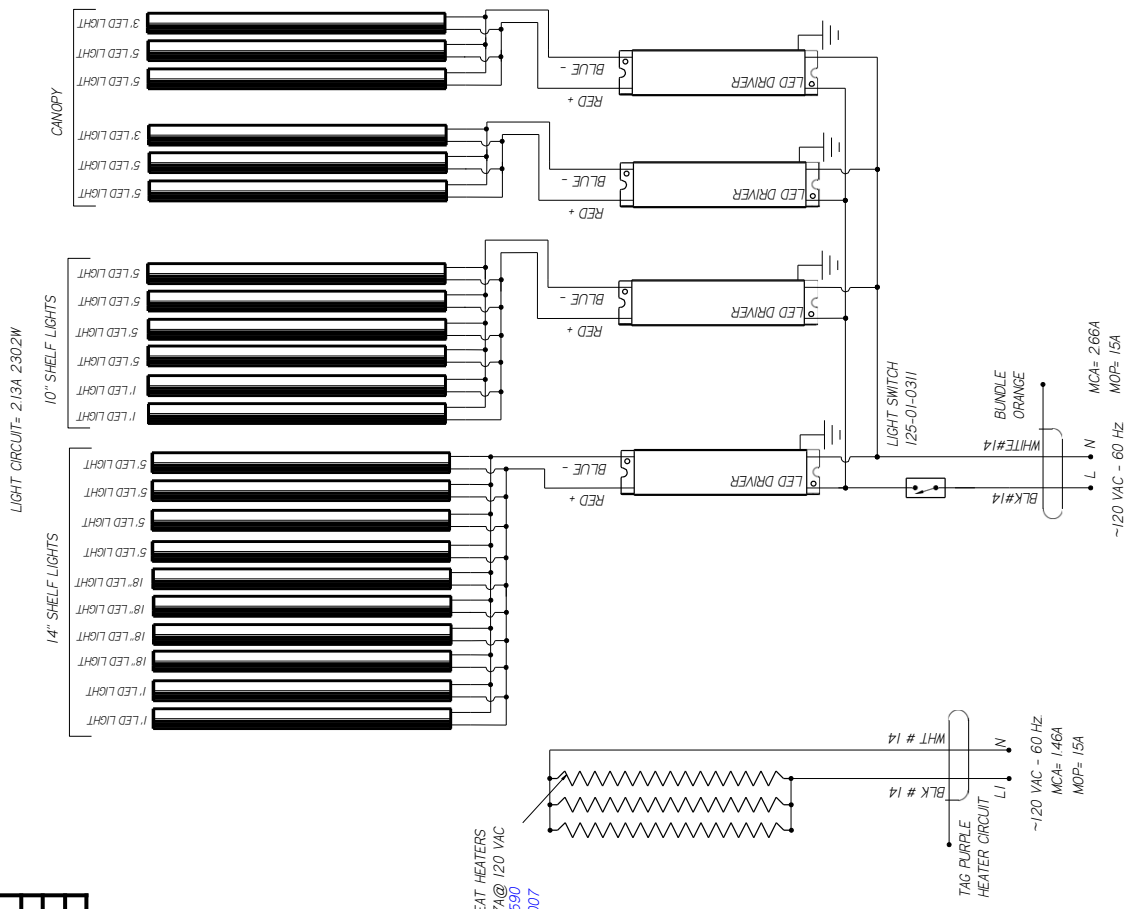
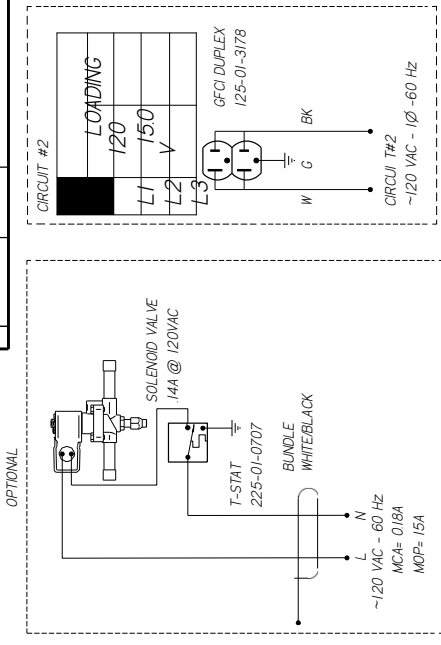

**HUSSMANN**  
**DIAGRAM-**  
**TY3ECRC- 6X161-R**

MATERIAL - N/A  
 DATE DRAWN - 4-3-18  
 DRAWN BY - CRAIG ROOREY  
 REVIEWED BY - CRAIG ROOREY  
 UNLESS OTHERWISE SPECIFIED DIMENSIONS ARE IN INCHES  
 TOLERANCES ARE:  
 DECIMALS .XX ±0.3 .XXX  
 ANGLES ±2°  
 PROJECTION

REF -  
 SHEET 1 OF 1  
 THIRD

3059427 | A

NOTES:  
 CASE MUST BE GROUNDED  
 WHEN PASSING WIRES THROUGH METAL HOLES A GROMMET MUST BE USED

| REV | EN | DATE       | REVISION DESCRIPTION                      | REV BY | CHKD BY | APPR BY |
|-----|----|------------|---|--------|---------|---------|
| 1   | A  | 2016/08/17 | ECN-CAP-0003235<br>RELEASED TO PRODUCTION | CB     | CB      | CB      |

| CIRCUIT #1 | LOADING | 120V | 18.7 |
|------------|---------|------|------|
|            |         |      |      |

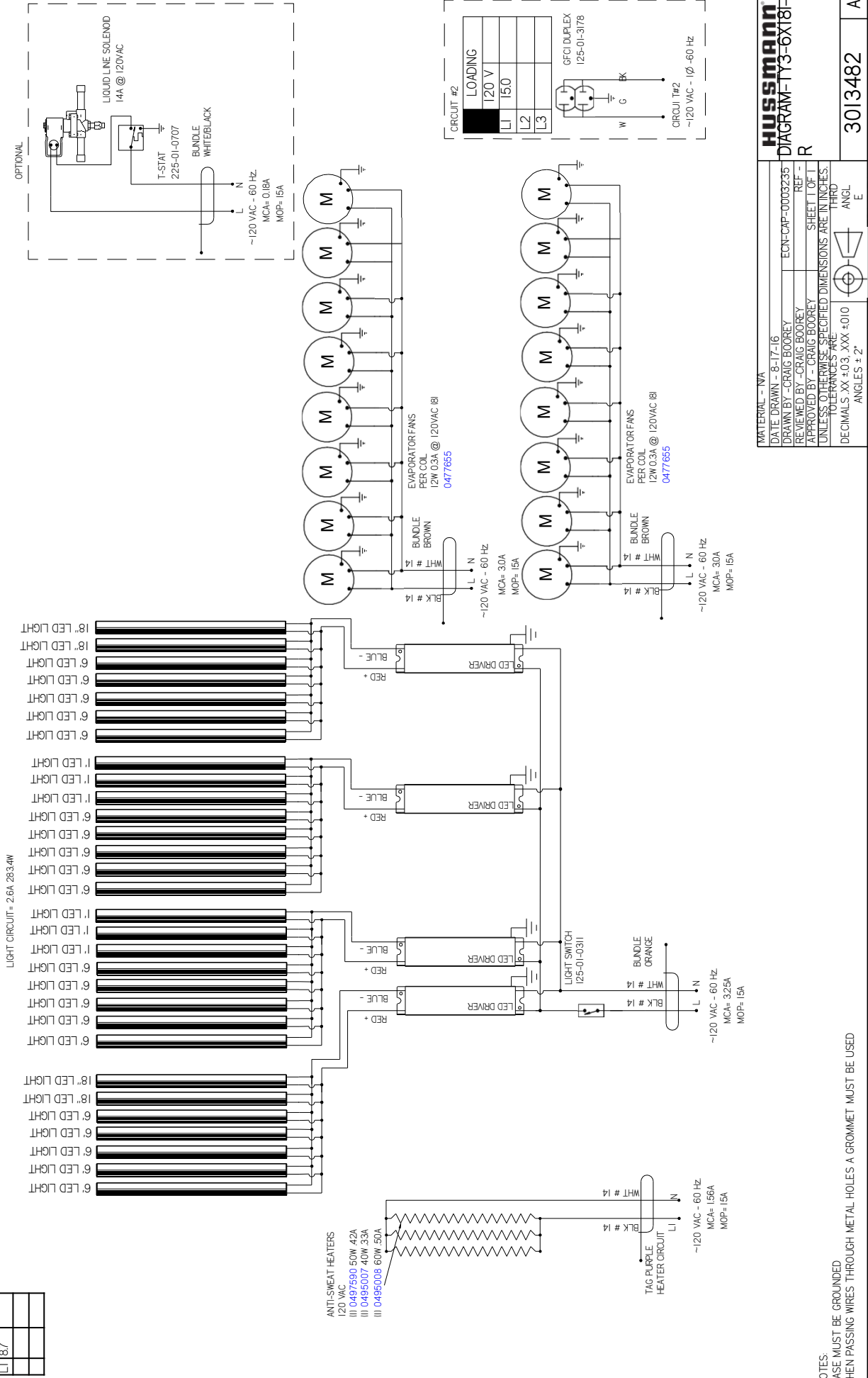

**HUSSMANN**  
**DIAGRAM-1Y3-6X181-R**

MATERIAL - NA  
DATE DRAWN - 8-17-16  
DRAWN BY - CRAIG BOOREY  
REVIEWED BY - CRAIG BOOREY  
APPROVED BY - CRAIG BOOREY  
UNLESS OTHERWISE SPECIFIED DIMENSIONS ARE IN INCHES.  
TOLERANCES ARE:  
DECIMALS .XX +0.3 .XXX +0.10  
ANGLES ± 2°

ECN-CAP-0003235  
REF -  
SHEET 1 OF 1  
THIRD

PROJECTION

3013482

A

NOTES:  
CASE MUST BE GROUNDED  
WHEN PASSING WIRES THROUGH METAL HOLES A GROMMET MUST BE USED

CIRCUIT #1

|         |  |
|---------|--|
| LOADING |  |
| 120V    |  |
| 150     |  |
| 20      |  |

LIGHT CIRCUIT  
53A 58.2W @ 120V

CANOPY LIGHTS

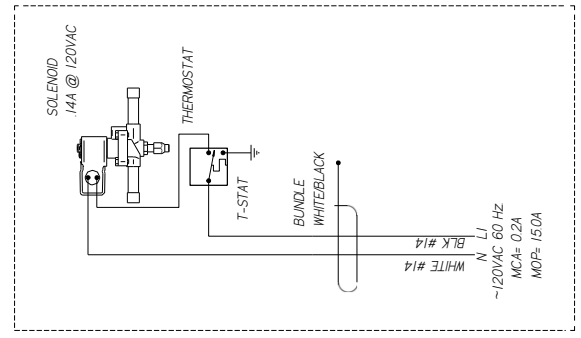
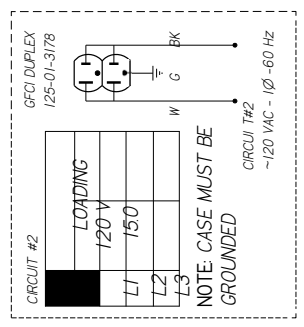
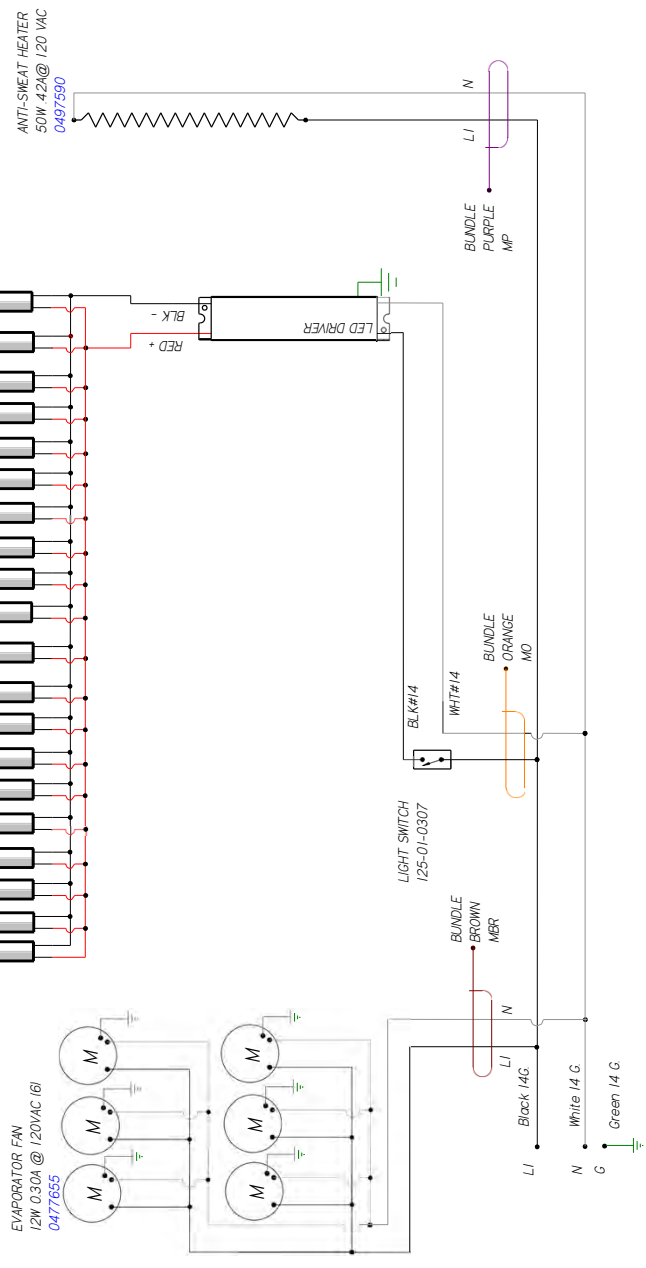
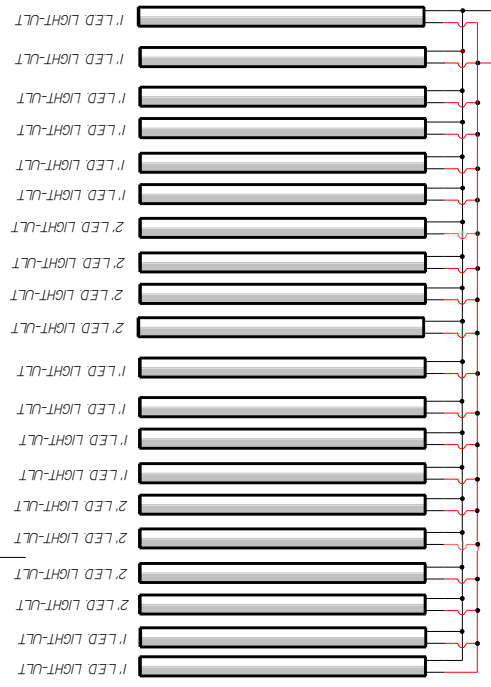

| REVISION HISTORY |                 | REV | BY | DATE       | DESCRIPTION            | CHKD BY | APPR BY |
|------------------|-----------------|-----|----|------------|------------------------|---------|---------|
| A                | ECN-CAP-0009957 | 1   | CB | 2017/04/13 | RELEASED TO PRODUCTION | CB      | CB      |
| B                | ECN-COD-0016286 | 2   | CB | 2022/04/09 | NEW LIGHTS             | CB      | CB      |

**HUSSMANN**  
DIAGRAM-1Y4-4X6I-R

MATERIAL - NA  
DATE DRAWN - 10-13-17  
DRAWN BY - CRAIG BOOREY  
REVIEWED BY - CRAIG BOOREY  
APPROVED BY - CRAIG BOOREY  
UNLESS OTHERWISE SPECIFIED DIMENSIONS ARE IN INCHES  
TOLERANCES ARE:  
DECIMALS .XX ±0.3 .XXX ±0.0  
ANGLES ± 2°  
PROJECTION  
E

ECN-CAP-0009957  
REF -  
SHEET 1 OF 1  
DIMENSIONS ARE IN INCHES  
THIRD ANGLE

3047021 | B

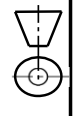

CIRCUIT #1

|      |  |
|------|--|
| 120V |  |
| 115V |  |
| 110V |  |
| 105V |  |

| REVISION HISTORY |                 | DATE       | REV. BY | CHKD. BY | APPR. BY |
|------------------|-----------------|------------|---------|----------|----------|
| A                | ECN-CAP-0003235 | 2016/08/17 | CB      | CB       | CB       |
| B                | ECN-COD-0015286 | 2022/04/20 | CB      | CB       | CB       |

LIGHT CIRCUIT  
128A 1352W @ 120V

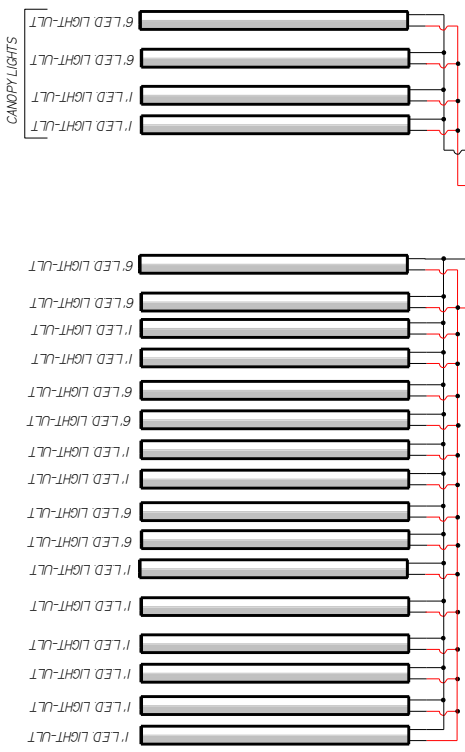

EMPIRATOR FAN  
12W @ 30A @ 120VAC (B)  
0477655

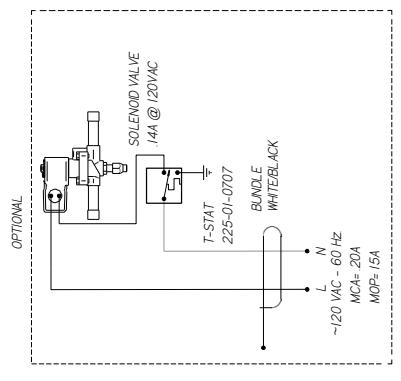
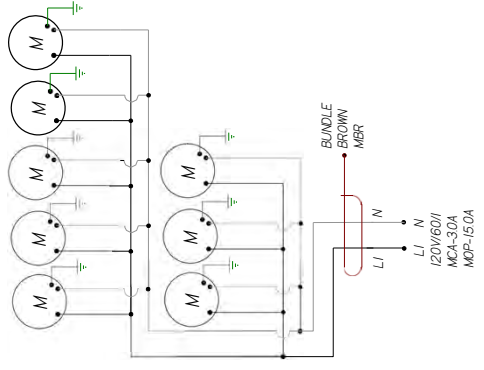

ANTI-SWEAT HEATER  
120 VAC  
III 0495007 40W, 33A  
III 0497590 50W, 42A

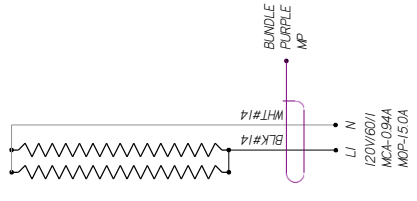

**HUSSMANN**  
DIAGRAM-1Y4-  
4X10I-R

MATERIAL - NA  
DATE DRAWN - 8-17-16  
DRAWN BY - CRAIG BOOREY  
REVIEWED BY - CRAIG BOOREY  
UNLESS OTHERWISE SPECIFIED DIMENSIONS ARE IN INCHES  
TOLERANCES ARE:  
DECIMALS .XX ±0.3 .XXX  
±0.0  
ANGLES ± 2°

ECN-CAP-0003235  
REF -  
SHEET 1 OF 1  
THIRD ANGLE PROJECTION

3013474 | B

NOTES:  
CASE MUST BE GROUNDED  
WHEN PASSING WIRES THROUGH METAL HOLES A GROMMET MUST BE USED

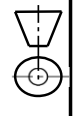

| REV | ECN            | DATE       | REVISION DESCRIPTION      | REV BY | CHKD BY | APPR BY |
|-----|----------------|------------|---------------------------|--------|---------|---------|
| A   | 743531         | 2016/07/17 | RELEASED TO PRODUCTION    | CB     | CB      | CB      |
| B   | 980241         | 2016/04/16 | CHANGED ANTI-SWEAT HEATER | CB     | CB      | CB      |
| C   | EDC-CDD-005298 | 2022/04/20 | NEW LIGHTS                | CB     | CB      | CB      |

REVISION HISTORY

| LOADING | 120 V |
|---------|-------|
| L1      | 15.0  |
| L2      |       |
| L3      |       |

CIRCUIT #2



CIRCUIT #2  
~120 VAC - 60 Hz

NOTE: CASE MUST BE GROUNDED



LIQUID LINE SOLENOID  
16A @ 120VAC

T-STAT  
225-01-0707

BUNDLE  
WHITE/BLACK

~120 VAC - 60 Hz  
MCA= 20A  
MOP= 15A

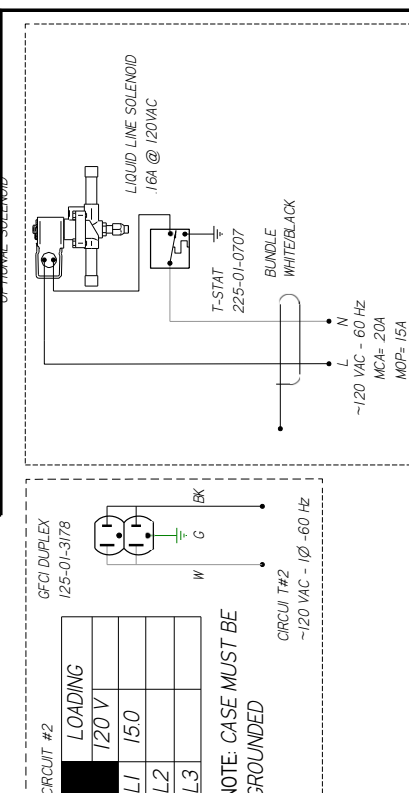

ANTI-SWEAT HEATERS  
60W 55A @ 120 VAC  
III 0495008  
50W 46A @ 120 VAC  
III 0497590

LED DRIVER

LED LIGHT

TOGGLE SWITCH  
125-01-0307

BUNDLE PURPLE  
MP

BUNDLE ORANGE  
MO

BUNDLE BROWN  
MBR

~120 VAC - 60 Hz  
MCA= 0.53A  
MOP= 15A

~120 VAC - 60 Hz  
MCA= 38A  
MOP= 15A

EVAPORATOR FANS  
12W 0.3A @ 120VAC  
III 0477655

EVAPORATOR FANS

EVAPORATOR FANS

EVAPORATOR FANS

EVAPORATOR FANS

EVAPORATOR FANS

EVAPORATOR FANS

EVAPORATOR FANS

EVAPORATOR FANS

EVAPORATOR FANS

EVAPORATOR FANS

EVAPORATOR FANS

EVAPORATOR FANS

EVAPORATOR FANS

EVAPORATOR FANS

EVAPORATOR FANS

EVAPORATOR FANS

EVAPORATOR FANS

EVAPORATOR FANS

EVAPORATOR FANS

EVAPORATOR FANS

EVAPORATOR FANS

EVAPORATOR FANS

EVAPORATOR FANS

EVAPORATOR FANS

EVAPORATOR FANS

EVAPORATOR FANS

EVAPORATOR FANS

EVAPORATOR FANS

EVAPORATOR FANS

EVAPORATOR FANS

EVAPORATOR FANS

EVAPORATOR FANS

EVAPORATOR FANS

EVAPORATOR FANS

EVAPORATOR FANS

EVAPORATOR FANS

EVAPORATOR FANS

EVAPORATOR FANS

EVAPORATOR FANS

EVAPORATOR FANS

EVAPORATOR FANS

EVAPORATOR FANS

EVAPORATOR FANS

EVAPORATOR FANS

EVAPORATOR FANS

EVAPORATOR FANS

EVAPORATOR FANS

EVAPORATOR FANS

EVAPORATOR FANS

EVAPORATOR FANS

EVAPORATOR FANS

EVAPORATOR FANS

EVAPORATOR FANS

EVAPORATOR FANS

EVAPORATOR FANS

EVAPORATOR FANS

EVAPORATOR FANS

EVAPORATOR FANS

EVAPORATOR FANS

EVAPORATOR FANS

EVAPORATOR FANS

EVAPORATOR FANS

EVAPORATOR FANS

EVAPORATOR FANS

EVAPORATOR FANS

EVAPORATOR FANS

EVAPORATOR FANS

EVAPORATOR FANS

EVAPORATOR FANS

EVAPORATOR FANS

EVAPORATOR FANS

EVAPORATOR FANS

EVAPORATOR FANS

EVAPORATOR FANS

EVAPORATOR FANS

EVAPORATOR FANS

EVAPORATOR FANS

EVAPORATOR FANS

EVAPORATOR FANS

EVAPORATOR FANS

EVAPORATOR FANS

EVAPORATOR FANS

EVAPORATOR FANS

EVAPORATOR FANS

EVAPORATOR FANS

EVAPORATOR FANS

EVAPORATOR FANS

EVAPORATOR FANS

EVAPORATOR FANS

EVAPORATOR FANS

EVAPORATOR FANS

EVAPORATOR FANS

EVAPORATOR FANS

EVAPORATOR FANS

EVAPORATOR FANS

EVAPORATOR FANS

EVAPORATOR FANS

EVAPORATOR FANS

EVAPORATOR FANS

EVAPORATOR FANS

EVAPORATOR FANS

EVAPORATOR FANS

EVAPORATOR FANS

EVAPORATOR FANS

EVAPORATOR FANS

EVAPORATOR FANS

EVAPORATOR FANS

EVAPORATOR FANS

EVAPORATOR FANS

EVAPORATOR FANS

EVAPORATOR FANS

EVAPORATOR FANS

EVAPORATOR FANS

EVAPORATOR FANS

EVAPORATOR FANS

EVAPORATOR FANS

EVAPORATOR FANS

EVAPORATOR FANS

EVAPORATOR FANS

EVAPORATOR FANS

EVAPORATOR FANS

EVAPORATOR FANS

EVAPORATOR FANS

EVAPORATOR FANS

EVAPORATOR FANS

EVAPORATOR FANS

EVAPORATOR FANS

EVAPORATOR FANS

EVAPORATOR FANS

EVAPORATOR FANS

EVAPORATOR FANS

EVAPORATOR FANS

EVAPORATOR FANS

EVAPORATOR FANS

EVAPORATOR FANS

EVAPORATOR FANS

EVAPORATOR FANS

EVAPORATOR FANS

EVAPORATOR FANS

EVAPORATOR FANS

EVAPORATOR FANS

EVAPORATOR FANS

EVAPORATOR FANS

EVAPORATOR FANS

EVAPORATOR FANS

EVAPORATOR FANS

EVAPORATOR FANS

EVAPORATOR FANS

EVAPORATOR FANS

EVAPORATOR FANS

EVAPORATOR FANS

EVAPORATOR FANS

EVAPORATOR FANS

EVAPORATOR FANS

EVAPORATOR FANS

EVAPORATOR FANS

EVAPORATOR FANS

EVAPORATOR FANS

EVAPORATOR FANS

EVAPORATOR FANS

EVAPORATOR FANS

EVAPORATOR FANS

EVAPORATOR FANS

EVAPORATOR FANS

EVAPORATOR FANS

EVAPORATOR FANS

EVAPORATOR FANS

EVAPORATOR FANS

EVAPORATOR FANS

EVAPORATOR FANS

EVAPORATOR FANS

EVAPORATOR FANS

EVAPORATOR FANS

EVAPORATOR FANS

EVAPORATOR FANS

EVAPORATOR FANS

EVAPORATOR FANS

EVAPORATOR FANS

EVAPORATOR FANS

EVAPORATOR FANS

EVAPORATOR FANS

EVAPORATOR FANS

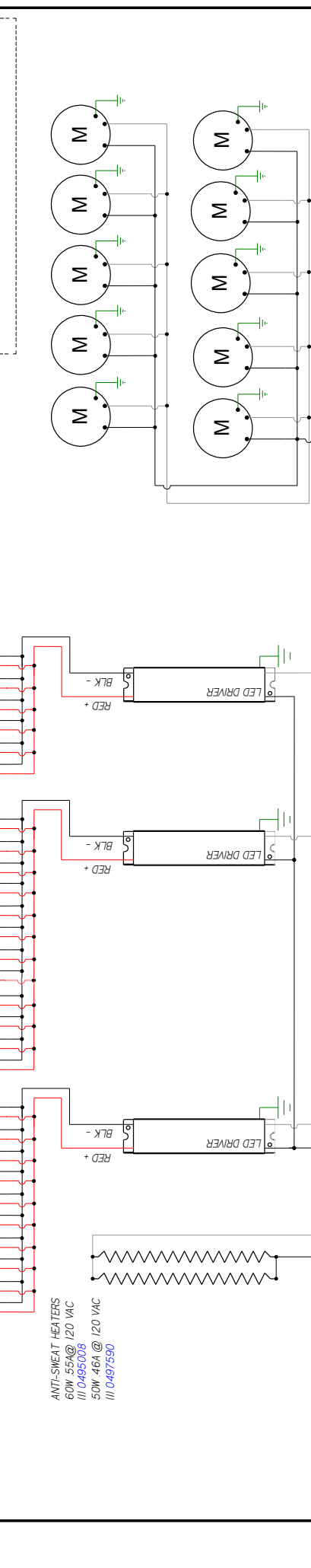

EVAPORATOR FANS  
12W 0.3A @ 120VAC  
III 0477655

EVAPORATOR FANS

EVAPORATOR FANS

EVAPORATOR FANS

EVAPORATOR FANS

EVAPORATOR FANS

EVAPORATOR FANS

EVAPORATOR FANS

EVAPORATOR FANS

EVAPORATOR FANS

EVAPORATOR FANS

EVAPORATOR FANS

EVAPORATOR FANS

EVAPORATOR FANS

EVAPORATOR FANS

EVAPORATOR FANS

EVAPORATOR FANS

EVAPORATOR FANS

EVAPORATOR FANS

EVAPORATOR FANS

EVAPORATOR FANS

EVAPORATOR FANS

EVAPORATOR FANS

EVAPORATOR FANS

EVAPORATOR FANS

EVAPORATOR FANS

EVAPORATOR FANS

EVAPORATOR FANS

EVAPORATOR FANS

EVAPORATOR FANS

EVAPORATOR FANS

EVAPORATOR FANS

EVAPORATOR FANS

EVAPORATOR FANS

EVAPORATOR FANS

EVAPORATOR FANS

EVAPORATOR FANS

EVAPORATOR FANS

EVAPORATOR FANS

EVAPORATOR FANS

EVAPORATOR FANS

EVAPORATOR FANS

EVAPORATOR FANS

EVAPORATOR FANS

EVAPORATOR FANS

EVAPORATOR FANS

EVAPORATOR FANS

EVAPORATOR FANS

EVAPORATOR FANS

| REVISION HISTORY |               | REV        | BY | DATE | DESCRIPTION | APP'D BY |
|------------------|---------------|------------|----|------|-------------|----------|
| 1                | 803263        | 2014/04/14 | CB | CB   | NEW DIAGRAM | CB       |
| 2                | EDVCCB-005286 | 2022/04/27 | CB | CB   | NEW LIGHTS  | CB       |

| CIRCUIT #1 | LOADING | 120V | 2-3 |
|------------|---------|------|-----|
|            |         |      |     |

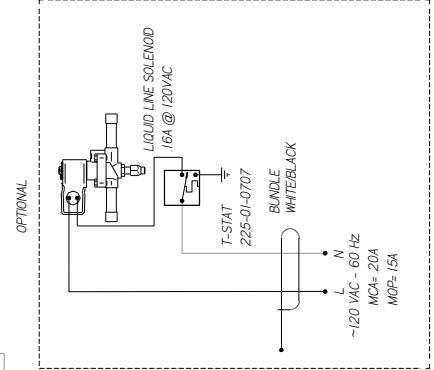
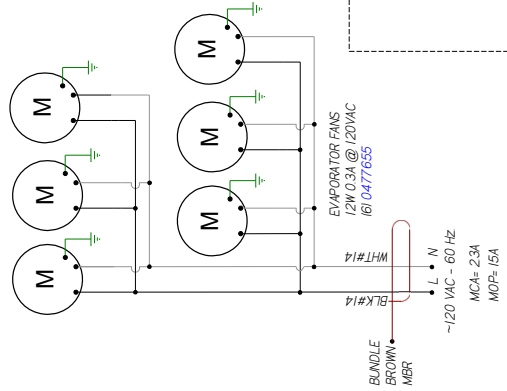
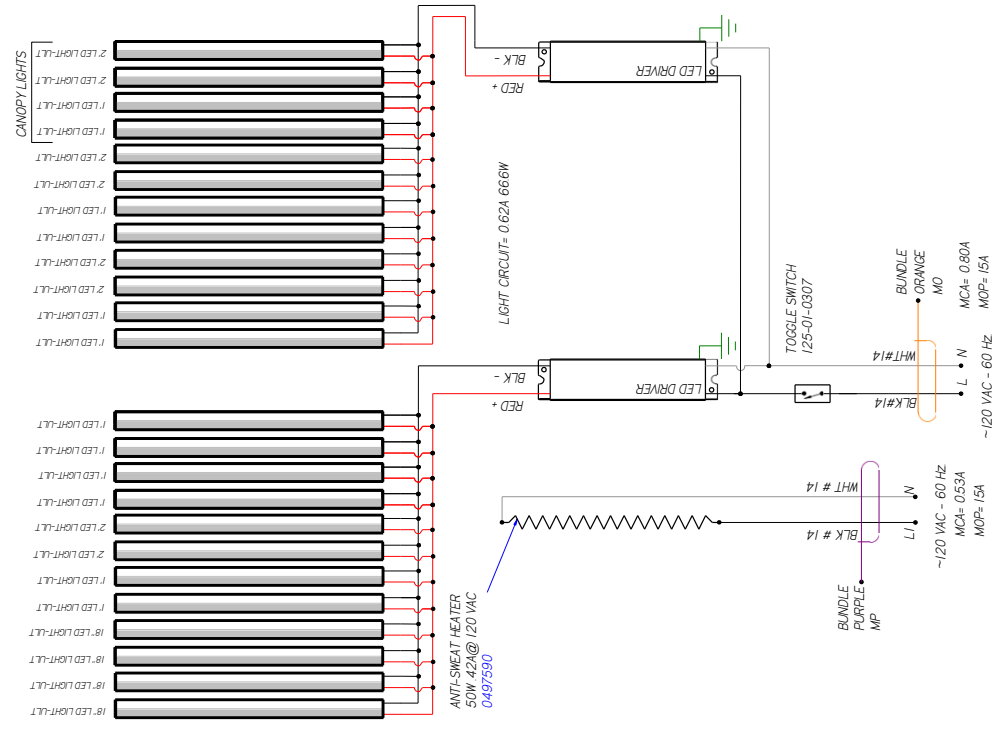
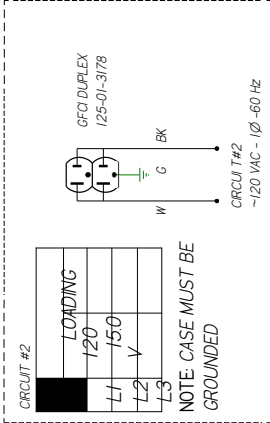

**MATERIAL - NA**

DATE DRAWN - 4/14/14

DRAWN BY - CRAIG BOOREY

REVIEWED BY - CRAIG BOOREY

APPROVED BY - CRAIG BOOREY

UNLESS OTHERWISE SPECIFIED DIMENSIONS ARE IN INCHES

TOLERANCES ARE:

THIRD ANGL

E

PROJECTION

ANGLES ± 2°

**HUSSMANN**

**DIAGRAM-IY4-**

**5X71-R**

**2H00212** | **B**

NOTES:  
CASE MUST BE GROUNDED

| REVISION HISTORY |                 |         |                        |
|------------------|-----------------|---------|------------------------|
| REV              | ECN             | DATE    | REVISION DESCRIPTION   |
| A                | ECN-000-0012732 | 2-25-21 | RELEASED TO PRODUCTION |
|                  |                 |         | REV BY / CHKD BY       |
|                  |                 |         | APPR BY                |
|                  |                 |         | CB                     |
|                  |                 |         | CB                     |
|                  |                 |         | CB                     |

| CIRCUIT #1 | LOADING |
|------------|---------|
| 120V       |         |
| 150        |         |
| L1         |         |
| L2         |         |
| L3         |         |

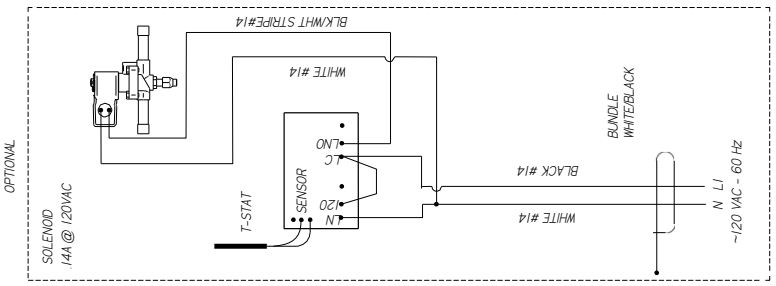
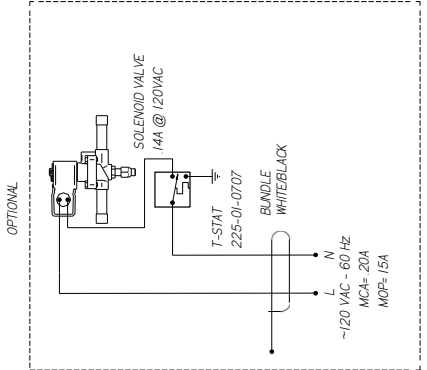
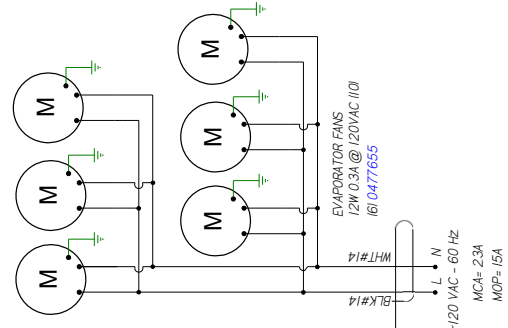
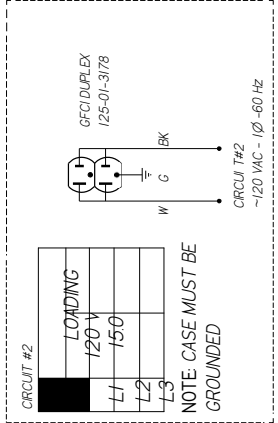
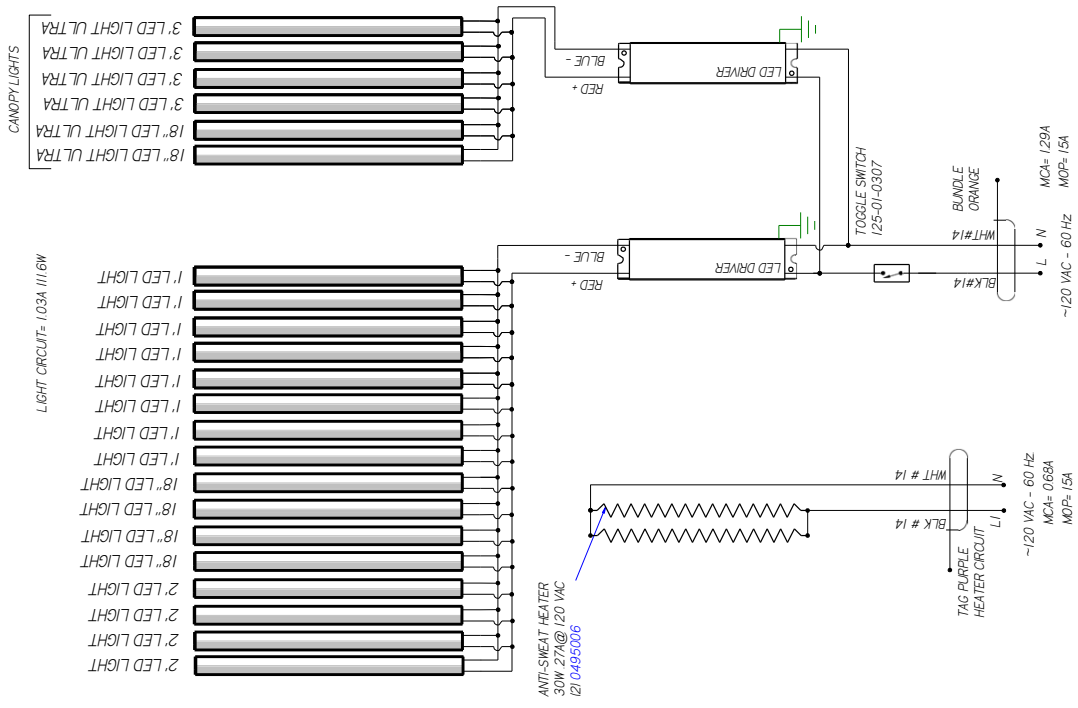

**HUSSMANN**

DIAGRAM-  
TY4ECRC- 5X7I-R

FACTORY 146A WIRE  
-FACTORY 106A WIRE  
-FIELD WIRE

DO NOT SCALE DRAWING  
SHEET 1 OF 1

3144548

UL COLOR CODES / ABBREVIATIONS

- RED = RD
- BLACK = BK
- BLUE = BL
- YELLOW = YL
- GRAY = GR
- WHITE = WT
- GREEN = GN
- BROWN = BN
- ORANGE = OR
- OR VIOLET = VT

- NOTES:
1. PRINTED DOCUMENT REQUIRED SETTING. ALL COLORS BLACK & WHITE
  2. CASE & ANY REMOVABLE PANEL WITH ELECTRICAL PARTS MUST BE GROUNDED.
  3. WHEN PASSING WIRES THROUGH METAL HOLES A GROMMET MUST BE USED

| REVISION HISTORY |                | REV | BY | DATE       | DESCRIPTION            | REV | BY | DATE       | DESCRIPTION            |
|------------------|----------------|-----|----|------------|------------------------|-----|----|------------|------------------------|
| 1                | LED/CAP-004942 | 1   | CB | 2018/01/26 | RELEASED TO PRODUCTION | 1   | CB | 2018/01/26 | RELEASED TO PRODUCTION |

CIRCUIT #1

|         |  |  |  |  |
|---------|--|--|--|--|
| LOADING |  |  |  |  |
| 120V    |  |  |  |  |
| L1      |  |  |  |  |
| L2      |  |  |  |  |
| L3      |  |  |  |  |

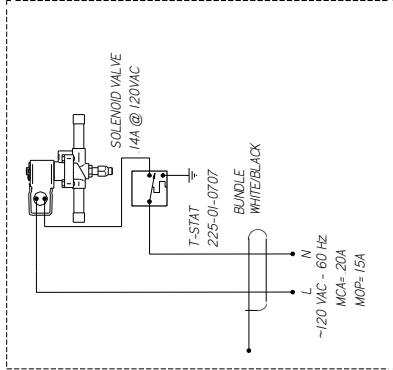
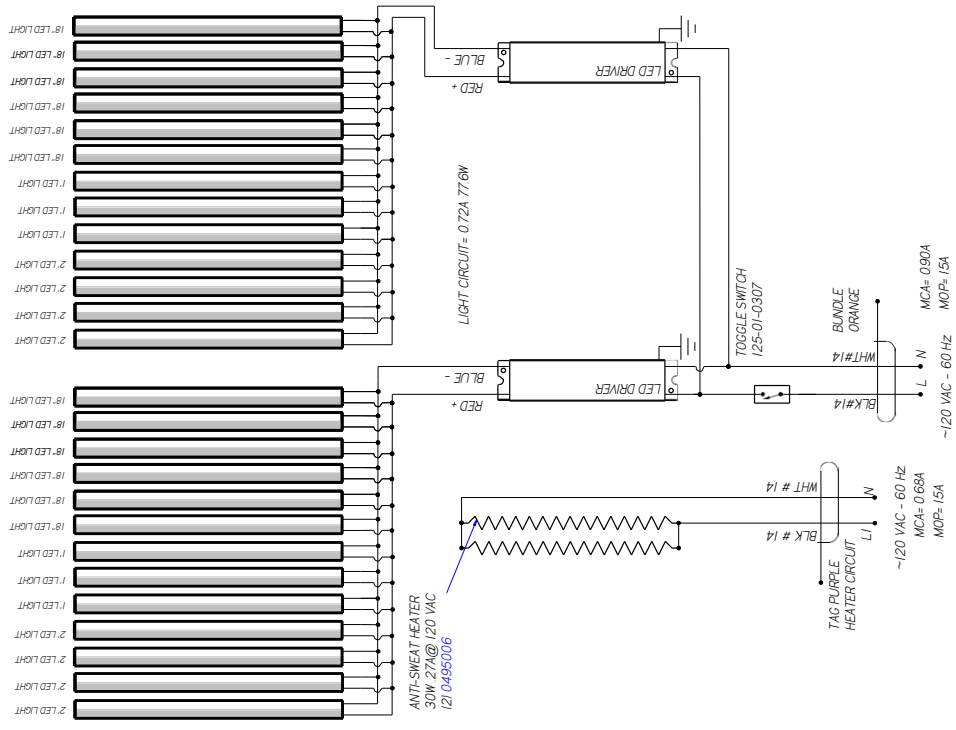
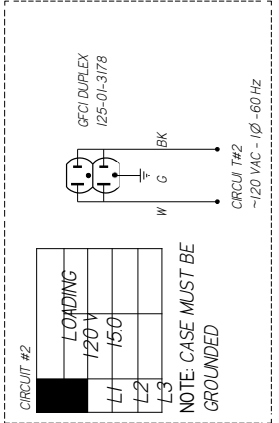

**HUSSMANN**  
DIAGRAM-IY4EC-5X7 I-R

MATERIAL - NA

DATE DRAWN - 10-26-18

DRAWN BY - CRAIG BOOREY

REVIEWED BY - CRAIG BOOREY

APPROVED BY - CRAIG BOOREY

UNLESS OTHERWISE SPECIFIED DIMENSIONS ARE IN INCHES

TOLERANCES ARE:

DECIMALS .XX ± 0.3 .XXX ± 0.10

ANGLES ± 2°

REF - SHEET 1 OF 3

THIRD ANGLE PROJECTION

3078669 | A

NOTES:  
CASE MUST BE GROUNDED  
WHEN PASSING WIRES THROUGH METAL HOLES A GROMMET MUST BE USED

| REV | EN             | DATE       | REVISION DESCRIPTION    | REV BY | CHKD BY | APPR BY |
|-----|----------------|------------|-------------------------|--------|---------|---------|
| A   | 983529         | 2016/08/03 | RELEASED TO PRODUCTION  | CB     | CB      | CB      |
| B   | ECN-CDD-006286 | 2022/04/27 | NEW LIGHTS              | CB     | CB      | CB      |
| C   | ECN-CDD-007638 | 2023/02/09 | REVISED SOLENOID WIRING | CB     | CB      | CB      |

| CIRCUIT #2 | LOADING |
|------------|---------|
|            | 120 V   |
| L1         | 150     |
| L2         |         |
| L3         |         |

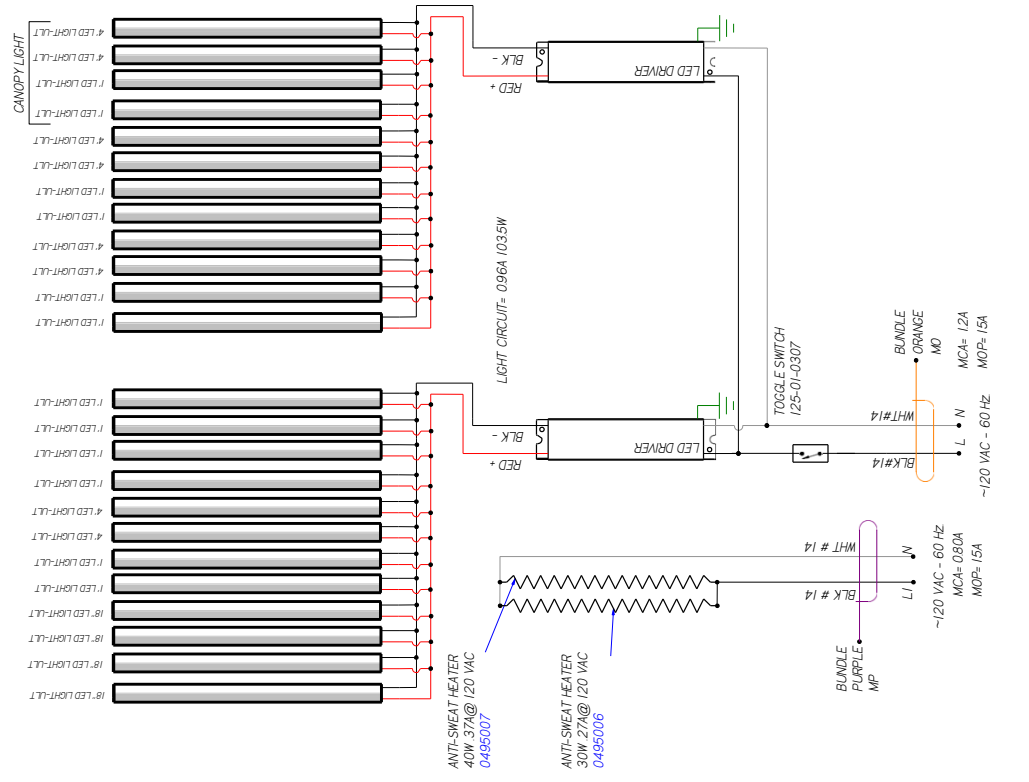
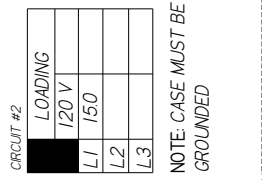

| CIRCUIT #1 | LOADING |
|------------|---------|
|            | 120 V   |
| L1         | 150     |
| L2         |         |
| L3         |         |

**HUSSMANN**  
**DIAGRAM-IY4-5X91-R**

MATERIAL - NA  
 DATE DRAWN - 6-3-15  
 DRAWN BY - CRAIG ROOREY  
 REVIEWED BY - CRAIG ROOREY  
 APPROVED BY - CRAIG ROOREY  
 UNLESS OTHERWISE SPECIFIED DIMENSIONS ARE IN INCHES  
 TOLERANCES ARE:  
 FRACTIONS XX ± 0.3, XXX ± 0.10  
 DECIMALS XX ± 0.3, XXX ± 0.10

REF - SHEET LOE  
 THIRD ANGL PROJECTION

2HI4403 | C

NOTES:  
 CASE MUST BE GROUNDED

| CIRCUIT #1 | LOADING |
|------------|---------|
|            | 120V    |
|            | L1      |
|            | L2      |
|            | L3      |

LIGHT CIRCUIT = 1.36A /466W

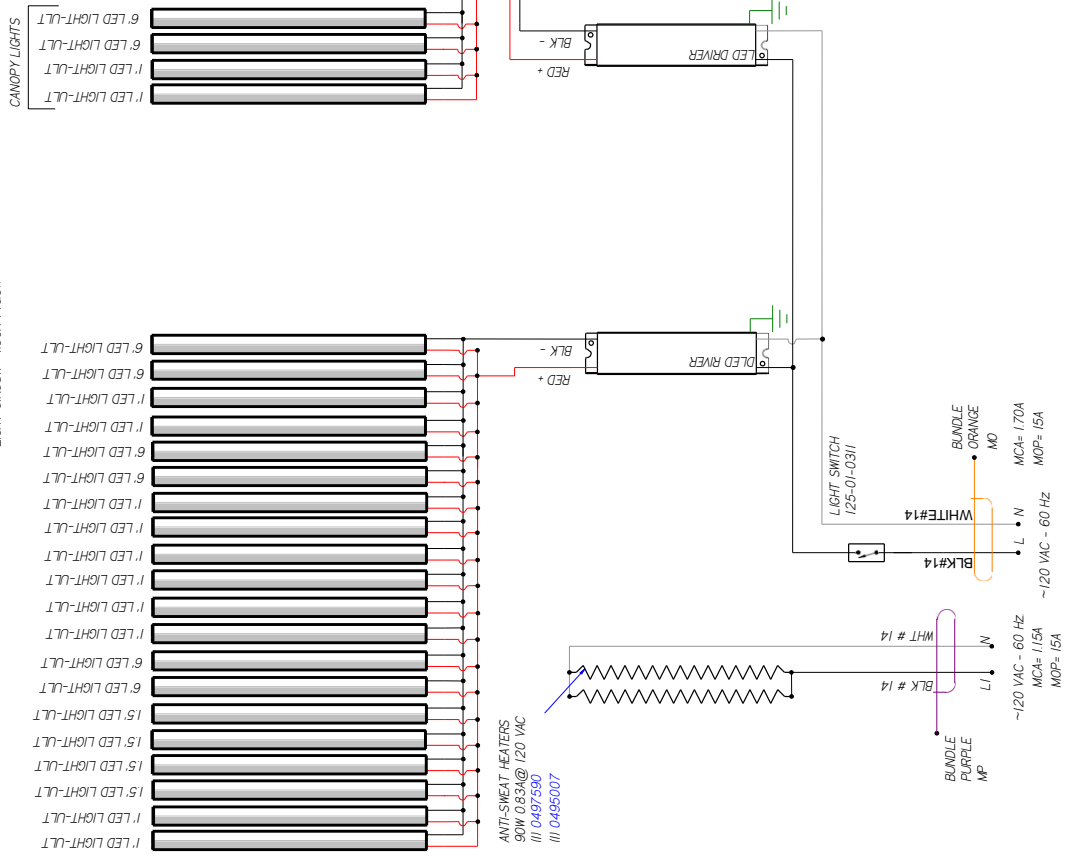

| REV | ECN             | DATE       | REVISION DESCRIPTION | REV BY | CHKD BY | APPR BY |
|-----|-----------------|------------|----------------------|--------|---------|---------|
| 1   | 765011          | 2023/09/24 | NEW DIAGRAM          | CB     | CB      | CB      |
| 2   | ECN-CDD-0015287 | 2022/04/25 | NEW LIGHTS           | CB     | CB      | CB      |

| REV | ECN             | DATE       | REVISION DESCRIPTION | REV BY | CHKD BY | APPR BY |
|-----|-----------------|------------|----------------------|--------|---------|---------|
| 1   | 765011          | 2023/09/24 | NEW DIAGRAM          | CB     | CB      | CB      |
| 2   | ECN-CDD-0015287 | 2022/04/25 | NEW LIGHTS           | CB     | CB      | CB      |

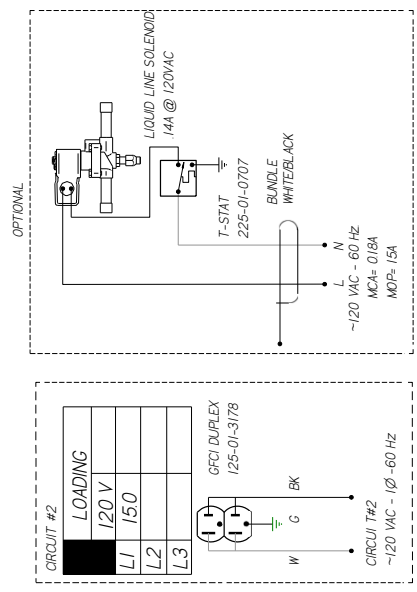

**HUSSMANN**  
**DIAGRAM-**  
**TY4-5X11-**  
**R**

MATERIAL - NA  
 DATE DRAWN - 9/24/13  
 DRAWN BY - CRAIG BOOREY  
 REVIEWED BY - CRAIG BOOREY  
 APPROVED BY - CRAIG BOOREY  
 UNLESS OTHERWISE SPECIFIED DIMENSIONS ARE IN INCHES  
 TOLERANCES ARE:  
 FRACTIONS XX ± 0.3, XXX  
 DECIMALS XX ± 0.0, XXX  
 ± 0.0

ECN# - 765011 REF - NEW  
 DIAGRA SHEET LOE  
 THIRD ANGL  
 E  
 PROJECTION

NOTES:  
 CASE MUST BE GROUNDED

CIRCUIT #

|     |         |                      |        |         |         |
|-----|---------|----------------------|--------|---------|---------|
| REV | DATE    | DESCRIPTION          | REV BY | CHKD BY | APPR BY |
| B   | 2-23-21 | ADDED 3RD LED DRIVER | CB     | CB      | CB      |
| C   | 3-29    | REVISED LIGHT LAYOUT | CB     | CB      | CB      |

| REV | DATE    | DESCRIPTION          | REV BY | CHKD BY | APPR BY |
|-----|---------|----------------------|--------|---------|---------|
| B   | 2-23-21 | ADDED 3RD LED DRIVER | CB     | CB      | CB      |
| C   | 3-29    | REVISED LIGHT LAYOUT | CB     | CB      | CB      |

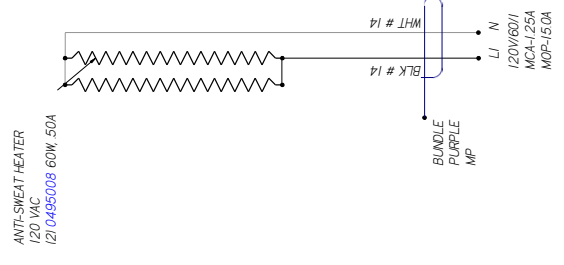
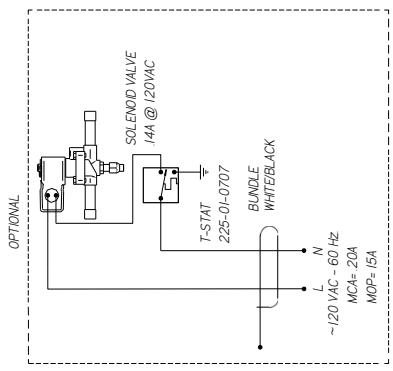
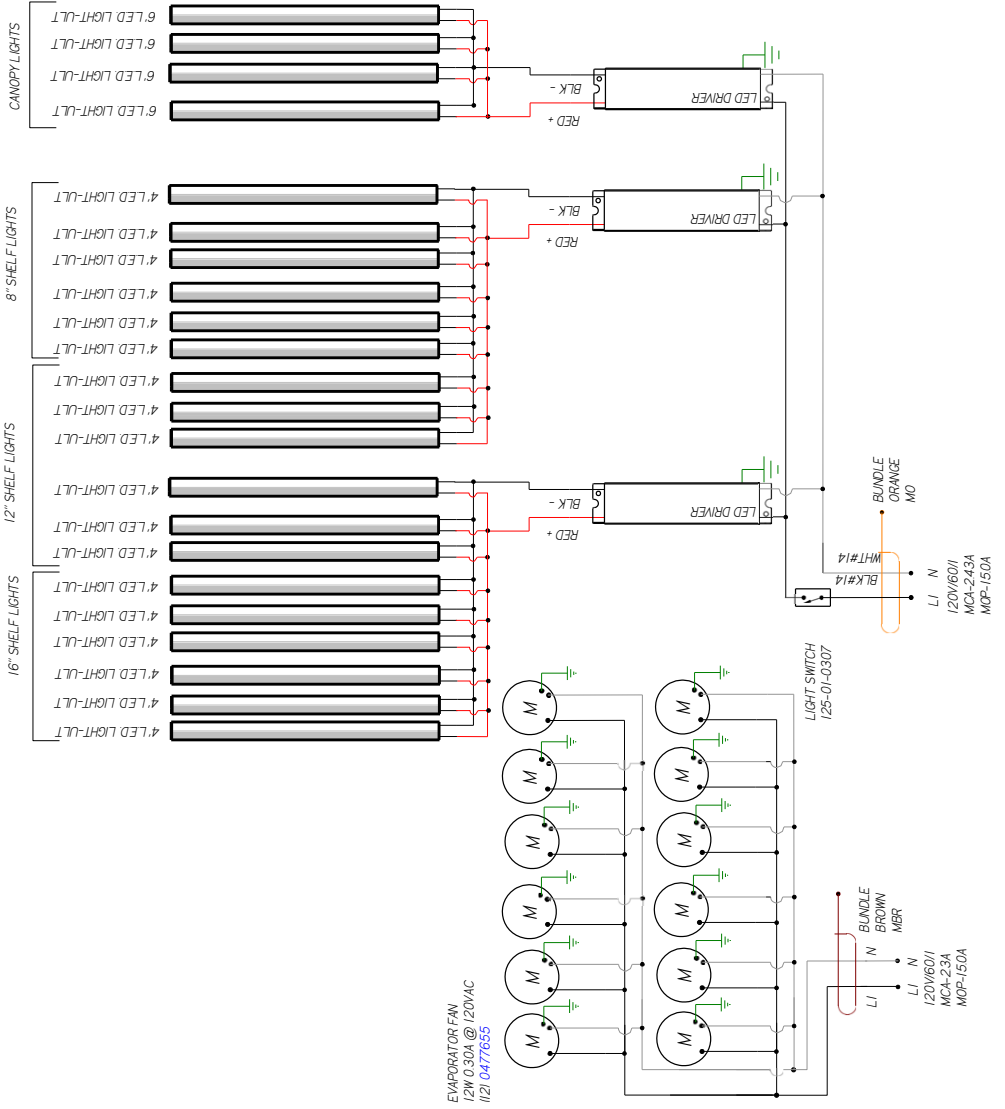

**UL COLOR CODES / ABBREVIATIONS**

|             |             |
|-------------|-------------|
| RED = RD    | WHITE = WT  |
| BLACK = BK  | GREEN = GN  |
| BLUE = BL   | BROWN = BN  |
| YELLOW = YL | ORANGE = OR |
| GRAY = GR   | VIOLET = VT |

**FACTORY 146A WIRE**

|                   |            |
|-------------------|------------|
| FACTORY 106A WIRE | FIELD WIRE |
| ---               | ---        |

**HUSSMANN**  
DIAGRAM-TY4-5X12C  
-R

DO NOT SCALE DRAWING  
SHEET 1 OF 1  
3142085

- NOTES:**
1. PRINTED DOCUMENT REQUIRED SETTING. ALL COLORS BLACK & WHITE
  2. CASE & ANY REMOVABLE PANEL WITH ELECTRICAL PARTS MUST BE GROUNDED.
  3. WHEN PASSING WIRES THROUGH METAL HOLES A GROMMET MUST BE USED

| REVISION HISTORY |                 |             |                         |
|------------------|-----------------|-------------|-------------------------|
| REV              | ECN             | DATE        | DESCRIPTION             |
| A                | 01/06/03        | 20/05/2015  | RELEASED FOR PRODUCTION |
| B                | ECN-000-004489  | 20/10/01/15 | REMOVED LED LIGHTS      |
| C                | ECN-000-0016287 | 20/22/04/25 | NEW LED LIGHTS          |

| CIRCUIT #1 |     |
|------------|-----|
| LOADING    |     |
| 120V       |     |
| L1         | 150 |
| L2         |     |
| L3         |     |

| CIRCUIT #2 |     |
|------------|-----|
| LOADING    |     |
| 120V       |     |
| L1         | 150 |
| L2         |     |
| L3         |     |

| CIRCUIT #3 |     |
|------------|-----|
| LOADING    |     |
| 120V       |     |
| L1         | 150 |
| L2         |     |
| L3         |     |

| CIRCUIT #4 |     |
|------------|-----|
| LOADING    |     |
| 120V       |     |
| L1         | 150 |
| L2         |     |
| L3         |     |

| CIRCUIT #5 |     |
|------------|-----|
| LOADING    |     |
| 120V       |     |
| L1         | 150 |
| L2         |     |
| L3         |     |

| CIRCUIT #6 |     |
|------------|-----|
| LOADING    |     |
| 120V       |     |
| L1         | 150 |
| L2         |     |
| L3         |     |

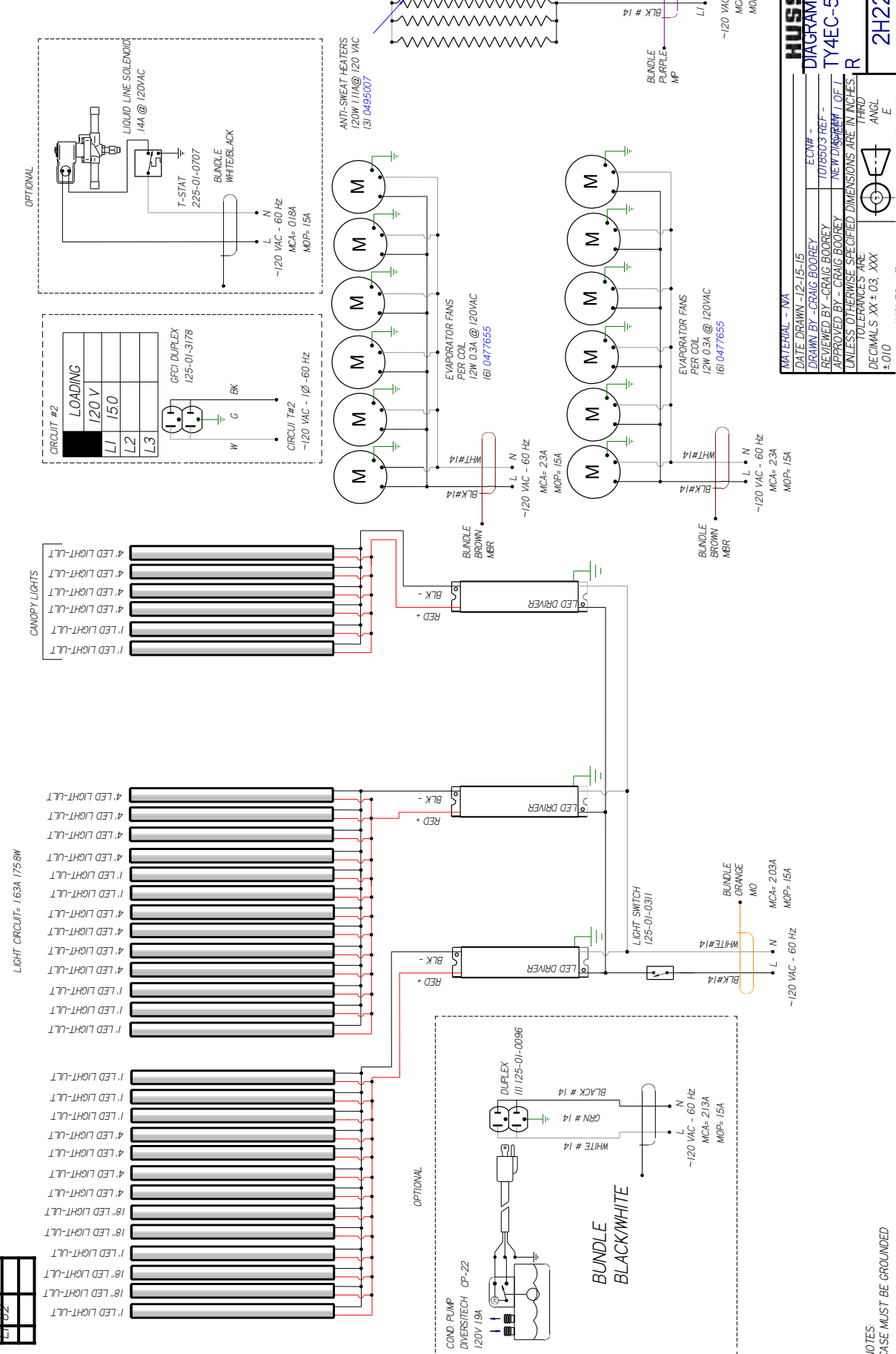

**MATERIAL - NA**  
 DATE DRAWN - 12-15-15  
 DRAWN BY - CRAIG BOOREY  
 REVIEWED BY - CRAIG BOOREY  
 APPROVED BY - CRAIG BOOREY  
 UNLESS OTHERWISE SPECIFIED DIMENSIONS ARE IN INCHES  
 TOLERANCES ARE:  
 FRACTIONS XX ± 0.3, XXX  
 DECIMALS .XX ± 0.03, .XXX ± 0.10  
 ANGLES ± 2°  
 PROJECTION  
 ANGLE  
 E

**HUSSMANN**  
**DIAGRAM-**  
**TY4EC-5X13-I**  
**R**

**2H22482** | **C**

NOTES:  
 CASE MUST BE GROUNDED



| REV | EN              | DATE     | REVISION HISTORY                    | REV BY | CHK BY | APP BY |
|-----|-----------------|----------|-------------------------------------|--------|--------|--------|
| A   | ECN-CAP-001913  | 20080313 | RELEASED TO PRODUCTION              | CB     | CB     | CB     |
| B   | ECN-COD-001343  | 20200914 | ADDED DRIVER FOR LEAD CANOPY LIGHTS | CB     | CB     | CB     |
| C   | ECN-COD-0015281 | 20220427 | NEW LIGHTS                          | CB     | CB     | CB     |

| LOADING | 120 V | 150 | 180 |
|---------|-------|-----|-----|
| L1      |       |     |     |
| L2      |       |     |     |
| L3      |       |     |     |

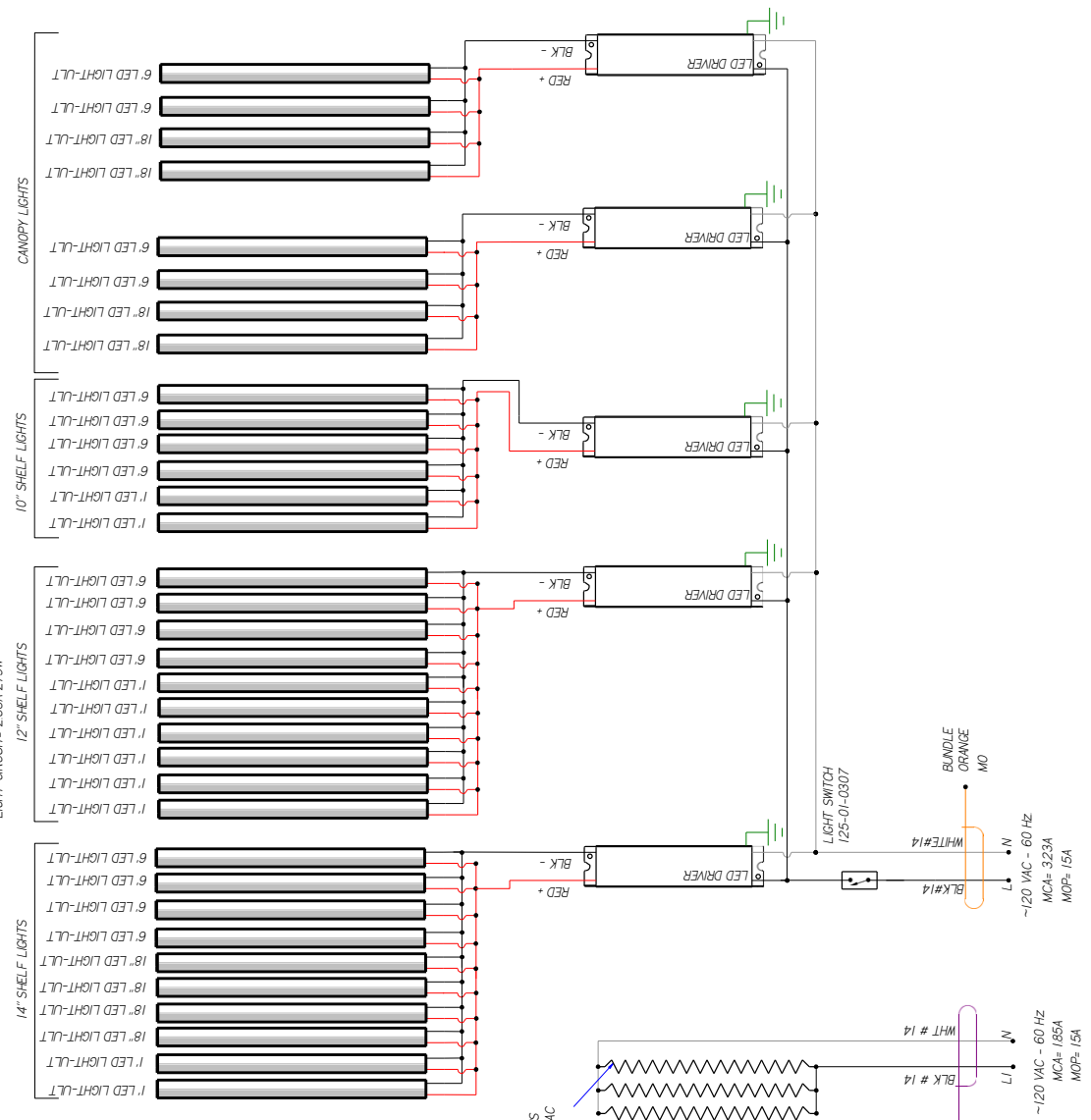
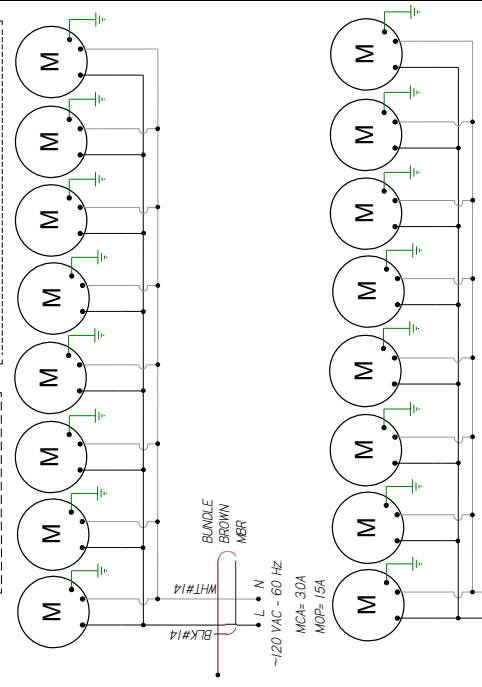
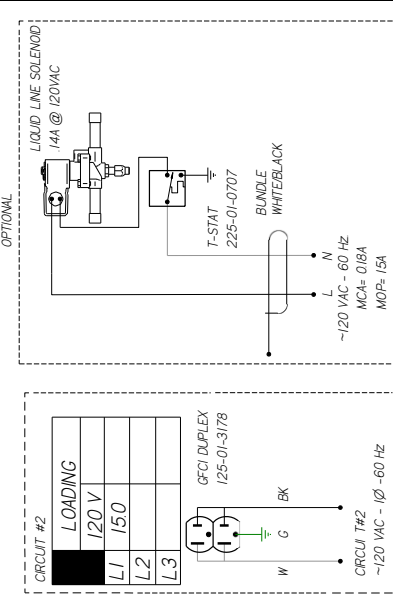

| CIRCUIT #1 | LOADING | 120 V | 150 | 180 |
|------------|---------|-------|-----|-----|
|            |         |       |     |     |

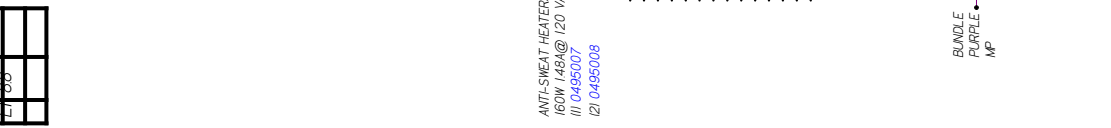

**HUSSMAN**  
**DIAGRAM-1Y4EC-**  
**5XI 71-R**

MATERIAL - IVA  
 DATE DRAWN - 3-13-18  
 DRAWN BY - CRAIG BOOREY  
 REVIEWED BY - CRAIG BOOREY  
 APPROVED BY - CRAIG BOOREY

ECN-CAP-001913 REF -  
 SHEET 1 OF 3  
 UNLESS OTHERWISE SPECIFIED DIMENSIONS ARE IN INCHES  
 TOLERANCES ARE:  
 FRACTIONS .XX ± 0.3 .XXX  
 DECIMALS .XX ± 0.3 .XXX  
 ANGLES ± 2°  
 PROJECTION

3058176 | C

NOTES:  
 CASE MUST BE GROUNDED  
 WHEN PASSING WIRES THROUGH METAL HOLES A GROMMET MUST BE USED



| REVISION HISTORY |                   | REV        | ECN | DATE        | DESCRIPTION | REV BY | CHKD BY | APPR BY |
|------------------|-------------------|------------|-----|-------------|-------------|--------|---------|---------|
| A                | 765011            | 2019/09/24 |     | NEW DIAGRAM | CB          | CB     | CB      | CB      |
| B                | LEGN-000-2018Z288 | 2022/04/27 |     | NEW LIGHTS  | CB          | CB     | CB      | CB      |

| CIRCUIT #1 | LOADING | 120V | 150 |
|------------|---------|------|-----|
| L1         |         |      |     |
| L2         |         |      |     |
| L3         |         |      |     |

| CIRCUIT #2 | LOADING | 120V | 150 |
|------------|---------|------|-----|
| L1         |         |      |     |
| L2         |         |      |     |
| L3         |         |      |     |

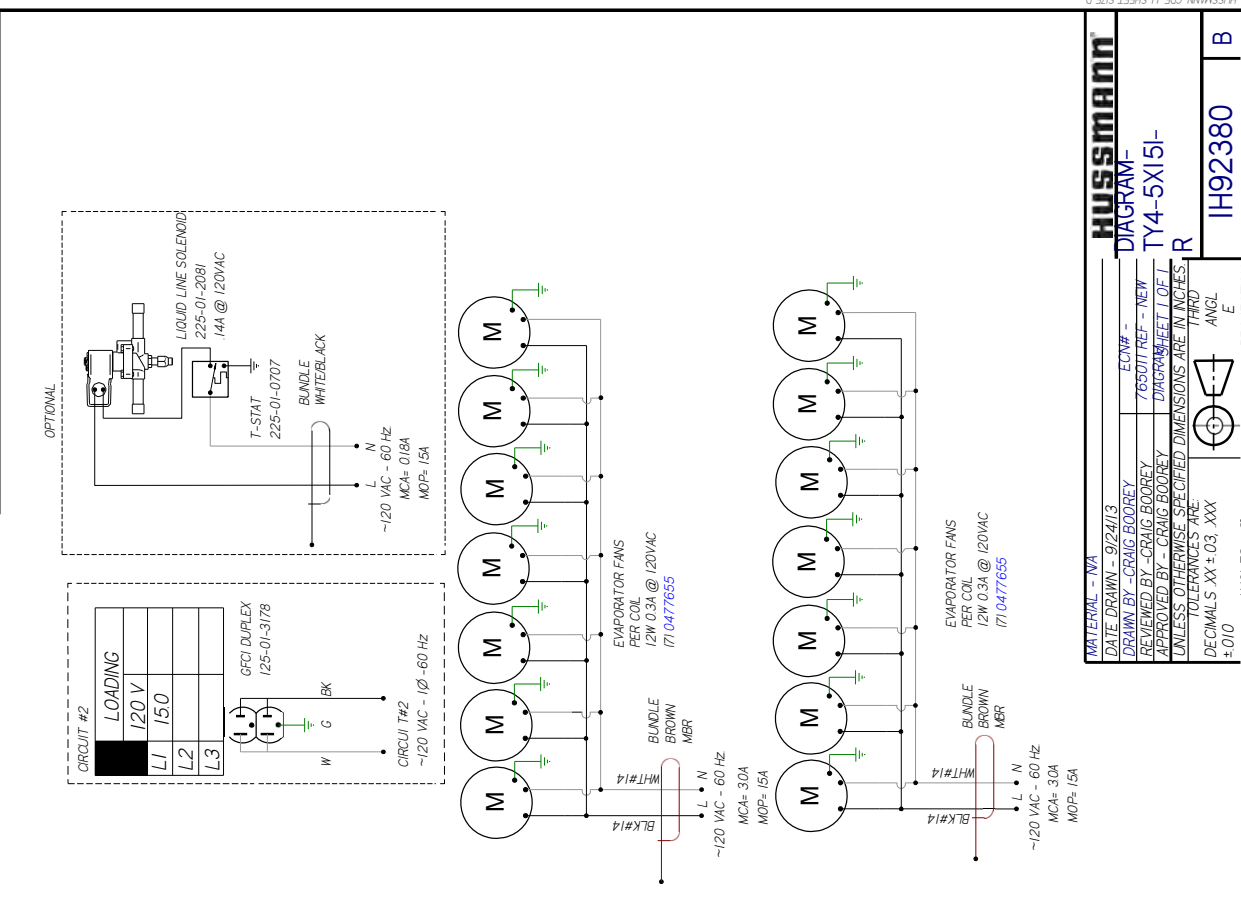

| CIRCUIT #1 | LOADING | 120V | 150 |
|------------|---------|------|-----|
| L1         |         |      |     |
| L2         |         |      |     |
| L3         |         |      |     |

| CIRCUIT #2 | LOADING | 120V | 150 |
|------------|---------|------|-----|
| L1         |         |      |     |
| L2         |         |      |     |
| L3         |         |      |     |

**HUSSMANN**  
DIAGRAM-  
TY4-5X151-  
R

MATERIAL - NA  
DATE DRAWN - 9/24/13  
DRAWN BY - CRAIG BOOREY  
REVIEWED BY - CRAIG BOOREY  
APPROVED BY - CRAIG BOOREY  
UNLESS OTHERWISE SPECIFIED DIMENSIONS ARE IN INCHES  
TOLERANCES ARE:  
DECIMALS .XX ± 0.3 .XXX  
± 0.10  
ANGLES ± 2°  
PROJECTION  
E  
ANGL

NOTES:  
CASE MUST BE GROUNDED

| REVISION HISTORY |                 |            |                            |
|------------------|-----------------|------------|----------------------------|
| REV              | EN              | DATE       | DESCRIPTION                |
| A                | ECN-CAP-0002200 | 2016/08/03 | RELEASED TO PRODUCTION     |
| B                | ECN-COD-0044489 | 2020/09/04 | ADDED DRIVER & ULTRALIGHTS |
| C                | ECN-COD-0052861 | 2022/04/28 | NEW LIGHTS                 |

| LOADING    |         |
|------------|---------|
| CIRCUIT #2 | LOADING |
| L1         | 150     |
| L2         |         |
| L3         |         |



ANTI-SWEAT HEATERS  
150W 1.39A @ 120 VAC  
III 0497590  
III 0495007  
III 0495008

LIGHT SWITCH  
125-01-0307  
BUNDLE ORANGE  
WHT #14  
BLK #14

LED DRIVER  
RED +  
BLK -

LED DRIVER  
RED +  
BLK -

LED DRIVER  
RED +  
BLK -

EVAPORATOR FANS  
PER COIL  
12W 0.3A @ 120VAC  
I161 0477655  
BUNDLE BROWN  
MBR  
WHT #14  
BLK #14

MOTOR (M)  
BUNDLE BROWN  
MBR  
WHT #14  
BLK #14

MOTOR (M)  
BUNDLE BROWN  
MBR  
WHT #14  
BLK #14

MOTOR (M)  
BUNDLE BROWN  
MBR  
WHT #14  
BLK #14

MOTOR (M)  
BUNDLE BROWN  
MBR  
WHT #14  
BLK #14

MOTOR (M)  
BUNDLE BROWN  
MBR  
WHT #14  
BLK #14

MOTOR (M)  
BUNDLE BROWN  
MBR  
WHT #14  
BLK #14

MOTOR (M)  
BUNDLE BROWN  
MBR  
WHT #14  
BLK #14

MOTOR (M)  
BUNDLE BROWN  
MBR  
WHT #14  
BLK #14

MOTOR (M)  
BUNDLE BROWN  
MBR  
WHT #14  
BLK #14

MOTOR (M)  
BUNDLE BROWN  
MBR  
WHT #14  
BLK #14

MOTOR (M)  
BUNDLE BROWN  
MBR  
WHT #14  
BLK #14

MOTOR (M)  
BUNDLE BROWN  
MBR  
WHT #14  
BLK #14

CANOPY LIGHTS  
6 LED LIGHT ULT  
6 LED LIGHT ULT  
6 LED LIGHT ULT  
6 LED LIGHT ULT  
6 LED LIGHT ULT  
6 LED LIGHT ULT  
6 LED LIGHT ULT  
6 LED LIGHT ULT  
6 LED LIGHT ULT  
6 LED LIGHT ULT

TOP SHELF  
6 LED LIGHT ULT  
6 LED LIGHT ULT  
6 LED LIGHT ULT  
6 LED LIGHT ULT  
6 LED LIGHT ULT  
6 LED LIGHT ULT  
6 LED LIGHT ULT  
6 LED LIGHT ULT  
6 LED LIGHT ULT  
6 LED LIGHT ULT

MID SHELF  
6 LED LIGHT ULT  
6 LED LIGHT ULT  
6 LED LIGHT ULT  
6 LED LIGHT ULT  
6 LED LIGHT ULT  
6 LED LIGHT ULT  
6 LED LIGHT ULT  
6 LED LIGHT ULT  
6 LED LIGHT ULT  
6 LED LIGHT ULT

BOTTOM SHELF  
6 LED LIGHT ULT  
6 LED LIGHT ULT  
6 LED LIGHT ULT  
6 LED LIGHT ULT  
6 LED LIGHT ULT  
6 LED LIGHT ULT  
6 LED LIGHT ULT  
6 LED LIGHT ULT  
6 LED LIGHT ULT  
6 LED LIGHT ULT

OPTIONAL  
LIQUID LINE SOLENOID  
144 @ 120VAC  
T-STAT 225-01-0707  
BUNDLE WHITE/BLACK  
-120 VAC - 60 Hz  
MCA= 018A  
MOP= 15A

GFCI DUPLEX  
125-01-3178  
W G BK  
CIRCUIT #2  
-120 VAC - 60 Hz

MATERIAL - NA  
DATE DRAWN - 6-3-16  
DRAWN BY - CRAIG BOOREY  
REVIEWED BY - CRAIG BOOREY  
APPROVED BY - CRAIG BOOREY  
UNLESS OTHERWISE SPECIFIED DIMENSIONS ARE IN INCHES  
TOLERANCES ARE:  
DECIMALS .XX ±0.3 .XXX  
±0.0 ANGLES ± 2°  
PROJECTION

HUSSMANN  
DIAGRAM-IY4-  
5X171-R

3008164 | C

NOTES:  
CASE MUST BE GROUNDED  
WHEN PASSING WIRES THROUGH METAL HOLES A GROMMET MUST BE USED



CIRCUIT #

|     |         |                        |        |         |         |
|-----|---------|------------------------|--------|---------|---------|
| REV | DATE    | DESCRIPTION            | REV BY | CHKD BY | APPR BY |
| A   | 9-19-19 | RELEASED TO PRODUCTION | CB     | CB      | CB      |

REVISION HISTORY

|     |         |                        |        |         |         |
|-----|---------|------------------------|--------|---------|---------|
| REV | DATE    | DESCRIPTION            | REV BY | CHKD BY | APPR BY |
| A   | 9-19-19 | RELEASED TO PRODUCTION | CB     | CB      | CB      |

CANOPY LIGHTS ES-CANOPY

LIGHT CIRCUIT  
1.25A 134.8W @ 120V

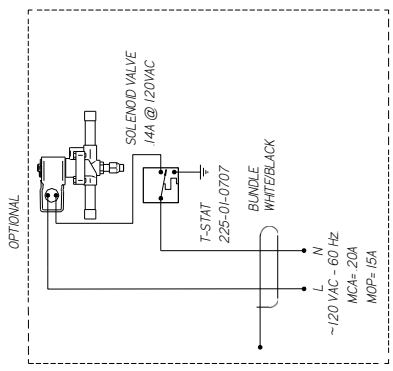
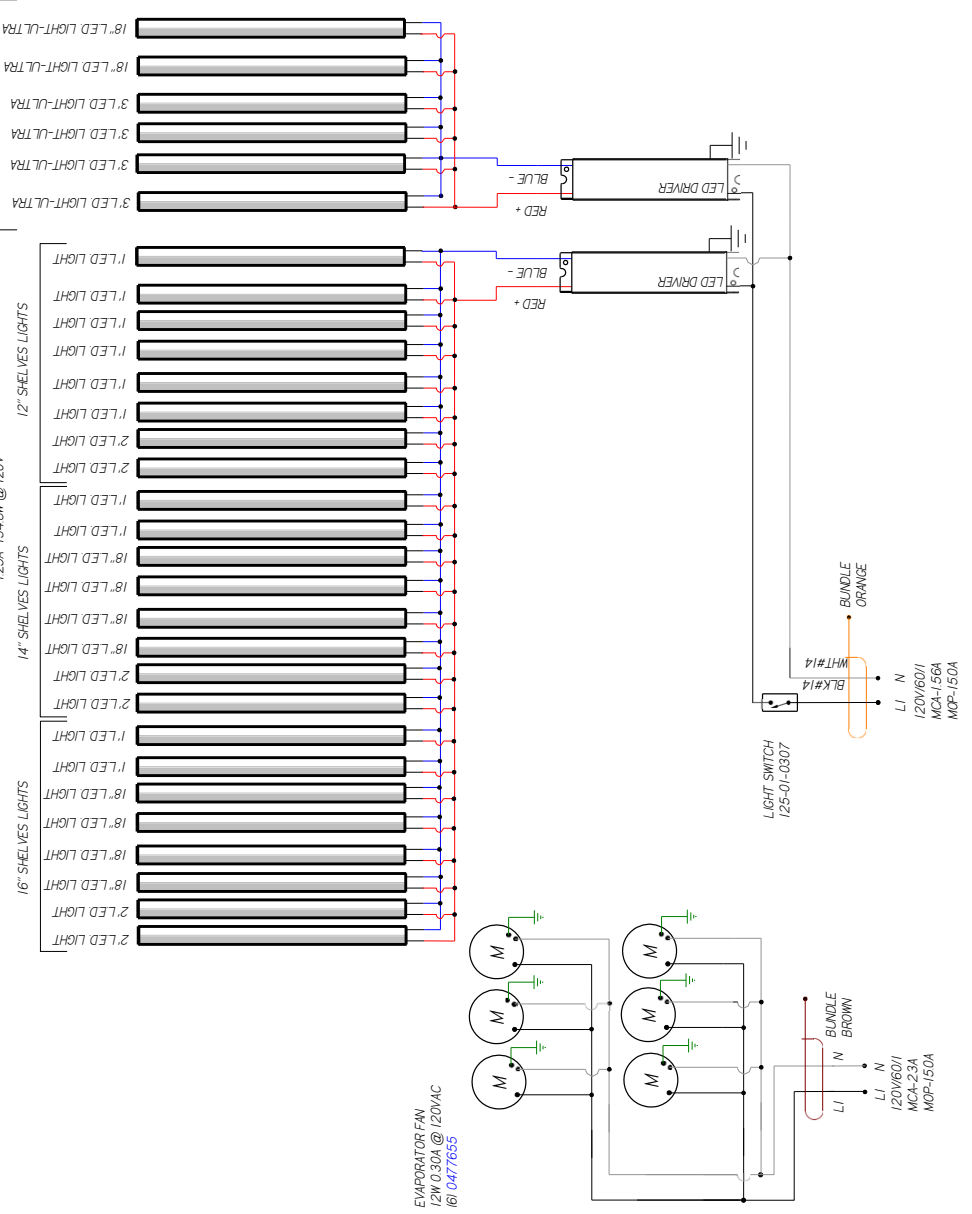

ANTI-SWEAT HEATER  
120 VAC  
121.0495006 30W, 27A

TAG PURPLE  
HEATER CIRCUIT

WHT # 14  
BLK # 14

LI N  
120V/60/1  
MCA-068A  
MOP-150A

EVAPORATOR FAN  
2W0.30A @ 120VAC  
161/0417655

LI N LI  
120V/60/1  
MCA-23A  
MOP-150A

LIGHT SWITCH  
125-01-0307

WHT #14  
BLK #14

LI N  
120V/60/1  
MCA-156A  
MOP-150A

BUNDLE  
ORANGE

WHT #14  
BLK #14

LI N  
120V/60/1  
MCA-156A  
MOP-150A

BUNDLE  
BROWN

LI N LI  
120V/60/1  
MCA-23A  
MOP-150A

**HUSSMANN**

DIAGRAM-  
TY4ECRC-6X8I-R

FACTORY 14GA WIRE  
FACTORY 10GA WIRE  
FIELD WIRE  
DO NOT SCALE DRAWING  
SHEET 1 OF 1

UL COLOR CODES / ABBREVIATIONS

|             |                |
|-------------|----------------|
| RED = RD    | WHITE = WT     |
| BLACK = BK  | GREEN = GN     |
| BLUE = BL   | BROWN = BN     |
| YELLOW = YL | ORANGE = OR    |
| GRAY = GR   | OR VIOLET = VT |

- NOTES:
1. PRINTED DOCUMENT REQUIRED SETTING. ALL COLORS BLACK & WHITE
  2. CASE & ANY REMOVABLE PANEL WITH ELECTRICAL PARTS MUST BE GROUNDED.
  3. WHEN PASSING WIRES THROUGH METAL HOLES A GROMMET MUST BE USED

3107535

A

CIRCUIT #

|     |         |                        |        |         |         |
|-----|---------|------------------------|--------|---------|---------|
| REV | DATE    | DESCRIPTION            | REV BY | CHKD BY | APPR BY |
| A   | 4-30-20 | RELEASED TO PRODUCTION | CB     | CB      | CB      |

| REVISION HISTORY |         |                        |        |         |         |
|------------------|---------|------------------------|--------|---------|---------|
| REV              | DATE    | DESCRIPTION            | REV BY | CHKD BY | APPR BY |
| A                | 4-30-20 | RELEASED TO PRODUCTION | CB     | CB      | CB      |

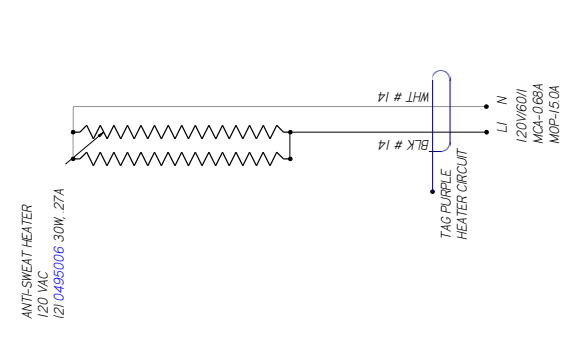
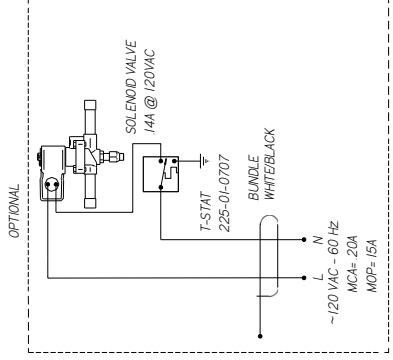
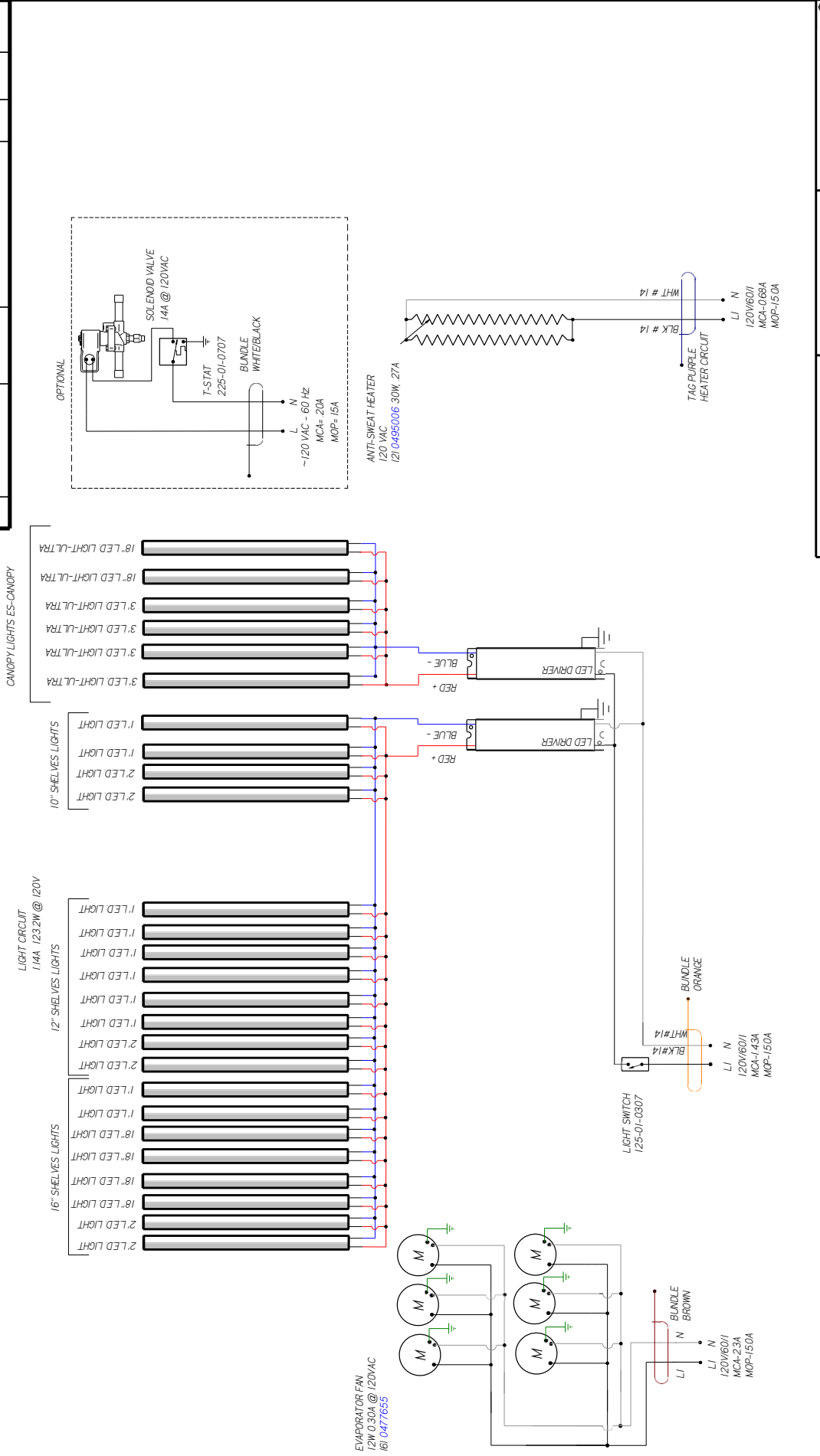

**HUSSMANN**  
**DIAGRAM-**  
**TY4ECRC- 6X8I-R**  
**W10",12" &**  
**16" SHELVE LIGHTS**  
**163753818**  
**SHEET 1 OF 1**

FACTORY 14GA WIRE  
 -FACTORY 10GA WIRE  
 -FIELD WIRE  
 -DO NOT SCALE DRAWING

UL COLOR CODES / ABBREVIATIONS  
 RED = RD  
 BLACK = BK  
 BLUE = BL  
 YL GRAY = YL GRAY  
 CY  
 WHITE = WT  
 GREEN = GN  
 BROWN = BN  
 ORANGE = OR  
 OR VIOLET = OR VIOLET  
 VT

- NOTES:
1. PRINTED DOCUMENT REQUIRED SETTING. ALL COLORS BLACK & WHITE
  2. CASE & ANY REMOVABLE PANEL WITH ELECTRICAL PARTS MUST BE GROUNDED.
  3. WHEN PASSING WIRES THROUGH METAL HOLES A GROMMET MUST BE USED

CIRCUIT #1

|      |      |      |      |
|------|------|------|------|
| 120V | 120V | 120V | 120V |
| 120V | 120V | 120V | 120V |
| 120V | 120V | 120V | 120V |

| REV | EN | DATE       | DESCRIPTION            | REV BY | CHKD BY | APPR BY |
|-----|----|------------|------------------------|--------|---------|---------|
| 1   |    | 2018/05/25 | RELEASED TO PRODUCTION | CB     | CB      | CB      |

LIGHT CIRCUIT  
160A 1724W @ 120V

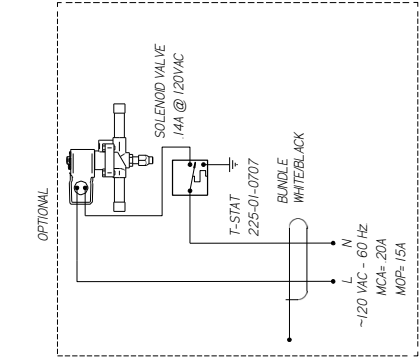
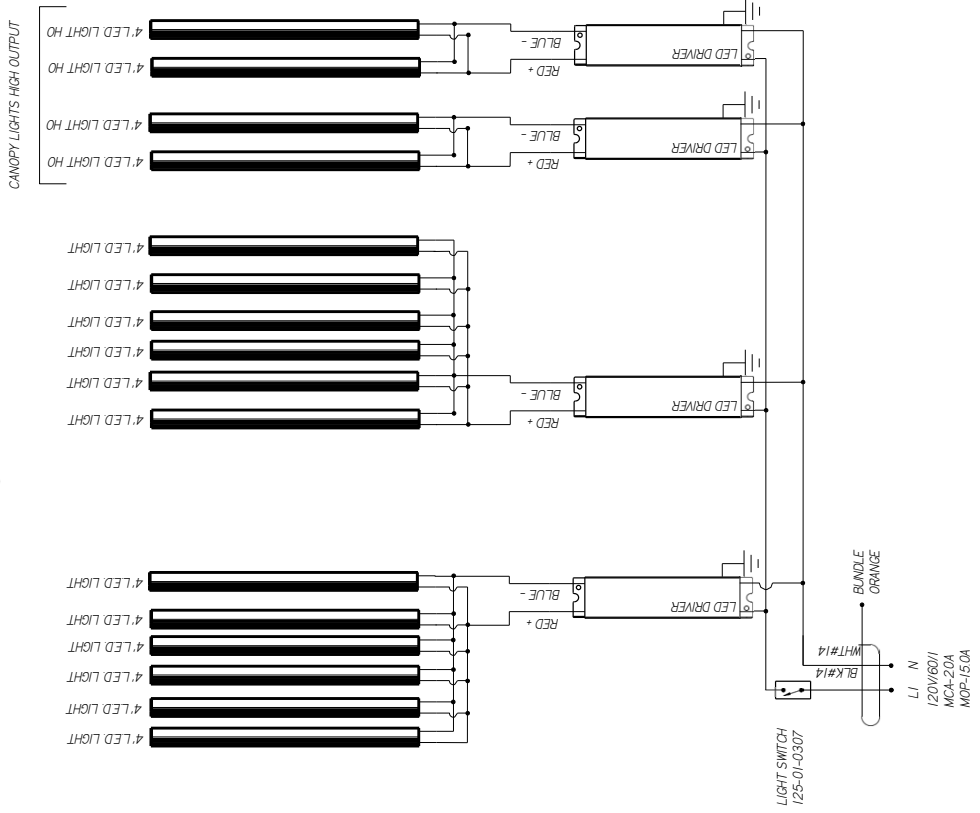

ANTI-SWEAT HEATER  
120 VAC  
121 0495007 40W, 33A

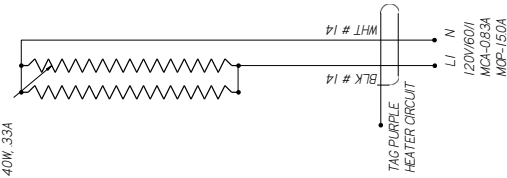
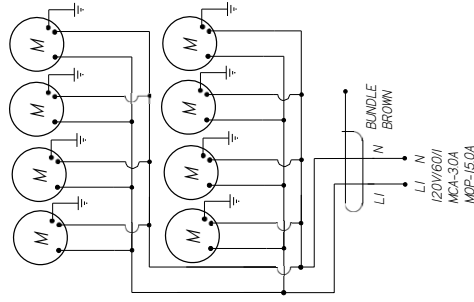

**HUSSMANN**  
DIAGRAM-  
TY4ECRC- 6X8C-R

MATERIAL - NA  
DATE DRAWN - 5-25-18  
DRAWN BY - CRAIG BOOREY  
REVIEWED BY - CRAIG BOOREY  
APPROVED BY - CRAIG BOOREY  
UNLESS OTHERWISE SPECIFIED DIMENSIONS ARE IN INCHES  
TOLERANCES ARE:  
DECIMALS .XX ±0.3 .XXX  
±0.0

ECN-CAP-0012696  
REF -  
SHEET 1 OF 1  
DIMENSIONS ARE IN INCHES  
THIRD ANGLE PROJECTION

3064025 | A



NOTES:  
CASE MUST BE GROUNDED  
WHEN PASSING WIRES THROUGH METAL HOLES A GROMMET MUST BE USED

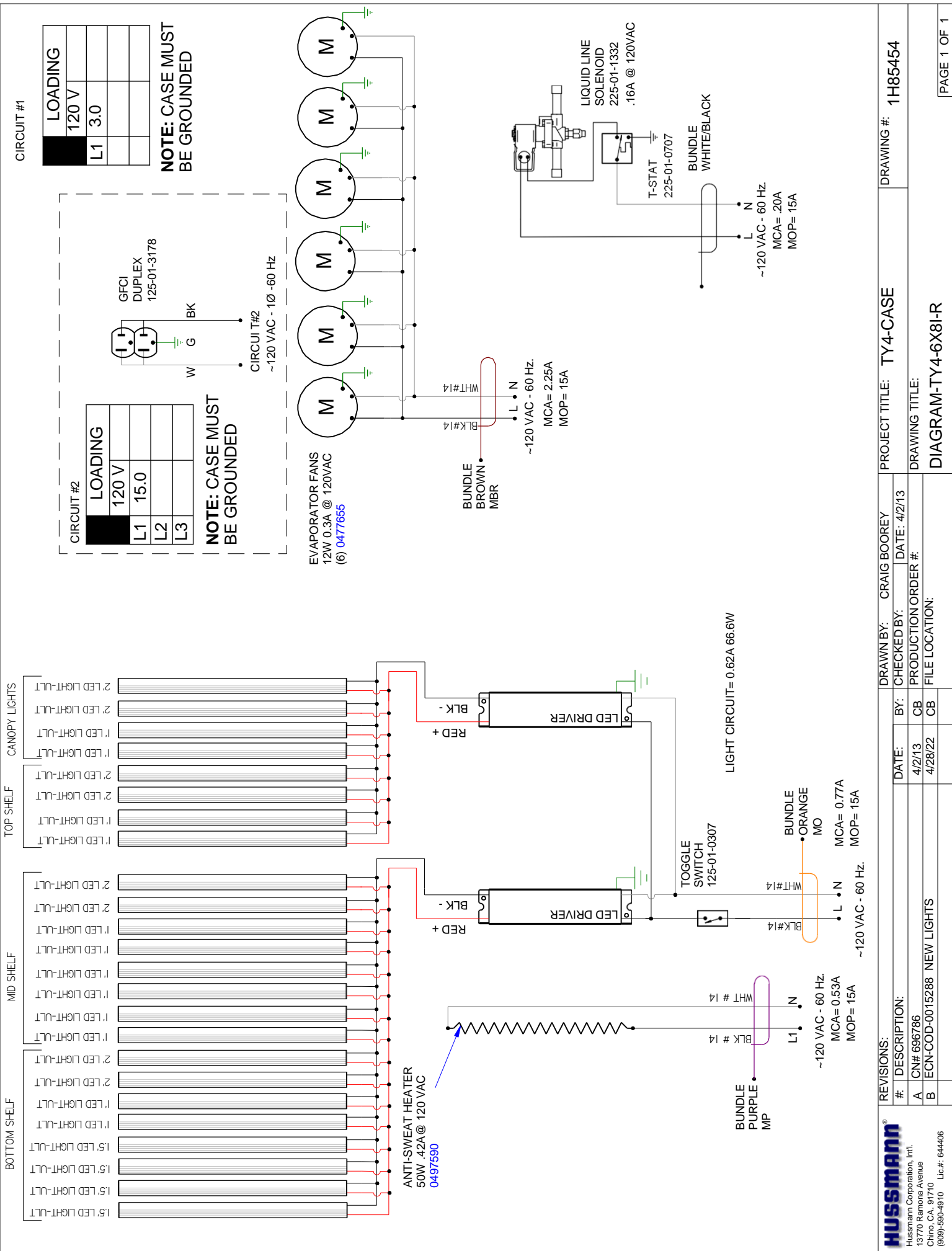

CIRCUIT #1

| CIRCUIT #2 | LOADING |
|------------|---------|
| L1         | 3.0     |
| L2         |         |
| L3         |         |

**NOTE: CASE MUST BE GROUNDED**

CIRCUIT #2

| CIRCUIT #2 | LOADING |
|------------|---------|
| L1         | 15.0    |
| L2         |         |
| L3         |         |

**NOTE: CASE MUST BE GROUNDED**

CIRCUIT #3

| CIRCUIT #2 | LOADING |
|------------|---------|
| L1         | 3.0     |
| L2         |         |
| L3         |         |

**NOTE: CASE MUST BE GROUNDED**

**REVISIONS:**

| # | DESCRIPTION:               | DATE:   | BY: |
|---|----------------------------|---------|-----|
| A | CN# 696786                 | 4/2/13  | CB  |
| B | ECN-COD-0015288 NEW LIGHTS | 4/28/22 | CB  |

**PROJECT TITLE: TY4-CASE**

**DRAWING #: 1H85454**

**DRAWING TITLE: DIAGRAM-TY4-6X8I-R**

**DRAWN BY: CRAIG BOOREY**

**CHECKED BY:**

**DATE: 4/2/13**

**PRODUCTION ORDER #:**

**FILE LOCATION:**

**HUSSMANN®**  
 Hussmann Corporation, Intl.  
 13770 Ramona Avenue  
 Chino, CA. 91710  
 (909)-590-4910 Lic.#: 644406

**PAGE 1 OF 1**

| REVISION HISTORY |                 |            |                           |
|------------------|-----------------|------------|---------------------------|
| REV              | EN              | DATE       | REV BY / CHG BY / APPR BY |
| A                | 765011          | 2023/10/22 | CB / CB / CB              |
| B                | ECN/ODD-0018268 | 2022/04/28 | CB / CB / CB              |
|                  |                 |            | NEW DIAGRAM               |
|                  |                 |            | NEW LIGHTS                |

| CIRCUIT #1 | LOADING |
|------------|---------|
| 120V       |         |
| L1         | 150     |
| L2         |         |
| L3         |         |

| CIRCUIT #2 | LOADING |
|------------|---------|
| 120        |         |
| L1         | 150     |
| L2         |         |
| L3         |         |

| CIRCUIT #2 | LOADING |
|------------|---------|
| 120        |         |
| L1         | 150     |
| L2         |         |
| L3         |         |

| CIRCUIT #2 | LOADING |
|------------|---------|
| 120        |         |
| L1         | 150     |
| L2         |         |
| L3         |         |

| CIRCUIT #2 | LOADING |
|------------|---------|
| 120        |         |
| L1         | 150     |
| L2         |         |
| L3         |         |

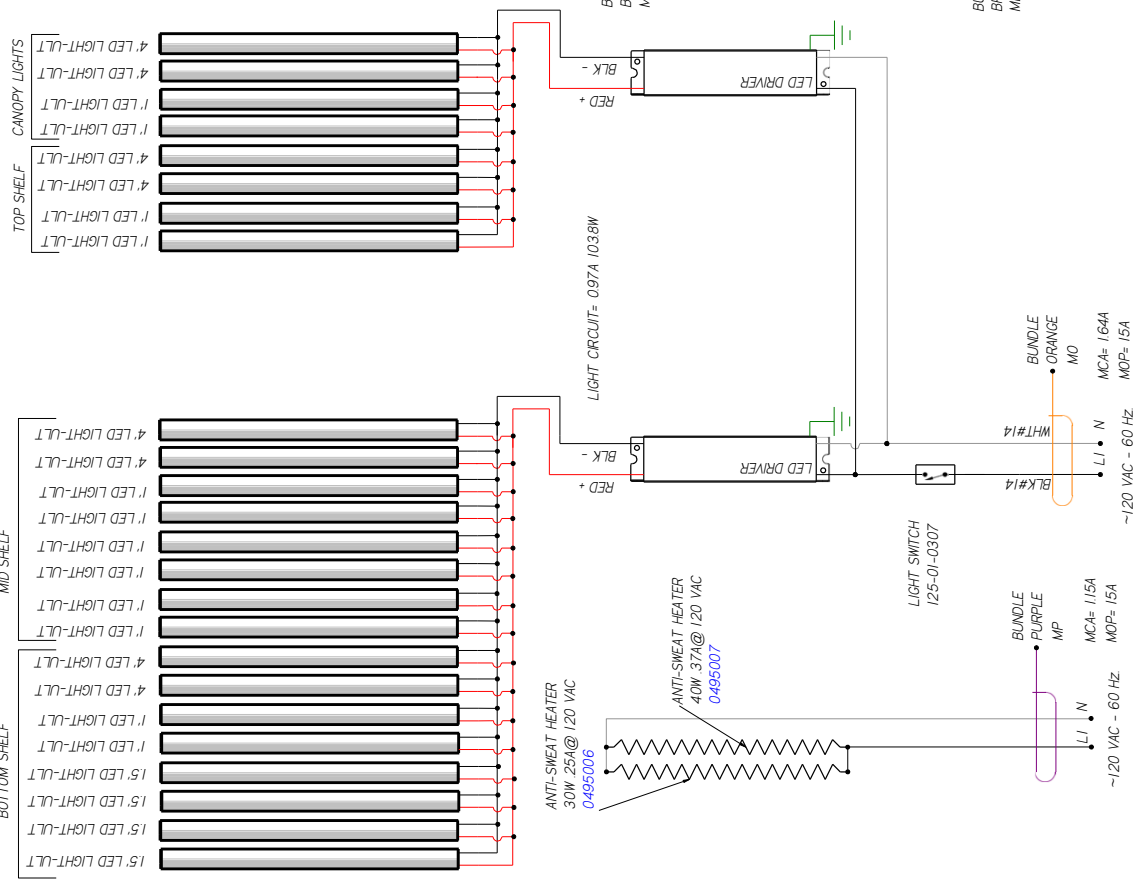
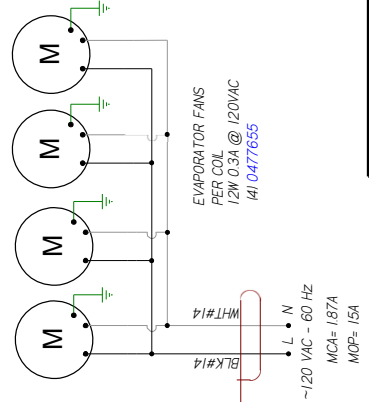
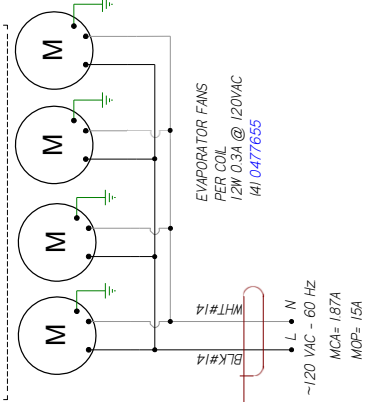
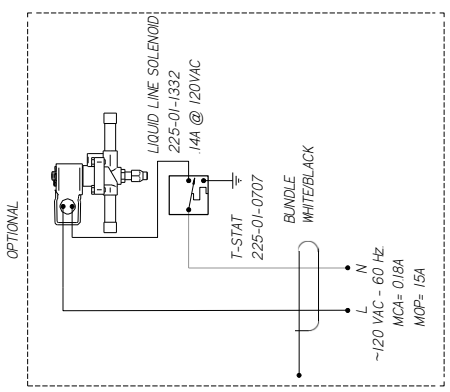
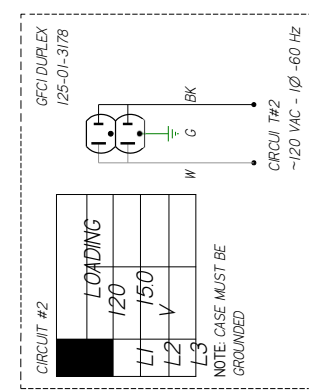

MATERIAL - N/A  
 DATE DRAWN - 10/22/13  
 DRAWN BY - CRAIG BOOREY  
 REVIEWED BY - CRAIG BOOREY  
 APPROVED BY - CRAIG BOOREY  
 UNLESS OTHERWISE SPECIFIED DIMENSIONS ARE IN INCHES  
 TOLERANCES ARE:  
 DECIMALS .XX ±0.3, .XXX  
 ANGLES ± 2°  
 PROJECTION

**HUSSMANN**  
 DIAGRAM -  
 TY4-6X101-  
 R  
 IH93524 | B

NOTES:  
 CASE MUST BE GROUNDED

| REVISION HISTORY |                  | REV        | DATE               | DESCRIPTION | BY | CHKD BY | APPR BY |
|------------------|------------------|------------|--------------------|-------------|----|---------|---------|
| B                | 248653           | 2013/06/02 | MATCH FAN REVISION | CY          | CY | CY      | CY      |
| C                | ECN# 001-0162683 | 2022/05/02 | NEW LIGHTS         | CB          | CB | CB      | CB      |

| REV | DATE             | DESCRIPTION | BY                 | CHKD BY | APPR BY |
|-----|------------------|-------------|--------------------|---------|---------|
| B   | 248653           | 2013/06/02  | MATCH FAN REVISION | CY      | CY      |
| C   | ECN# 001-0162683 | 2022/05/02  | NEW LIGHTS         | CB      | CB      |

| CIRCUIT #1 | LOADING | 120V | 150V |
|------------|---------|------|------|
| 1          | 120     |      |      |
| 2          | 150     |      |      |
| 3          |         |      |      |

| CIRCUIT #2 | LOADING | 120V | 150V |
|------------|---------|------|------|
| 1          | 120     |      |      |
| 2          | 150     |      |      |
| 3          |         |      |      |

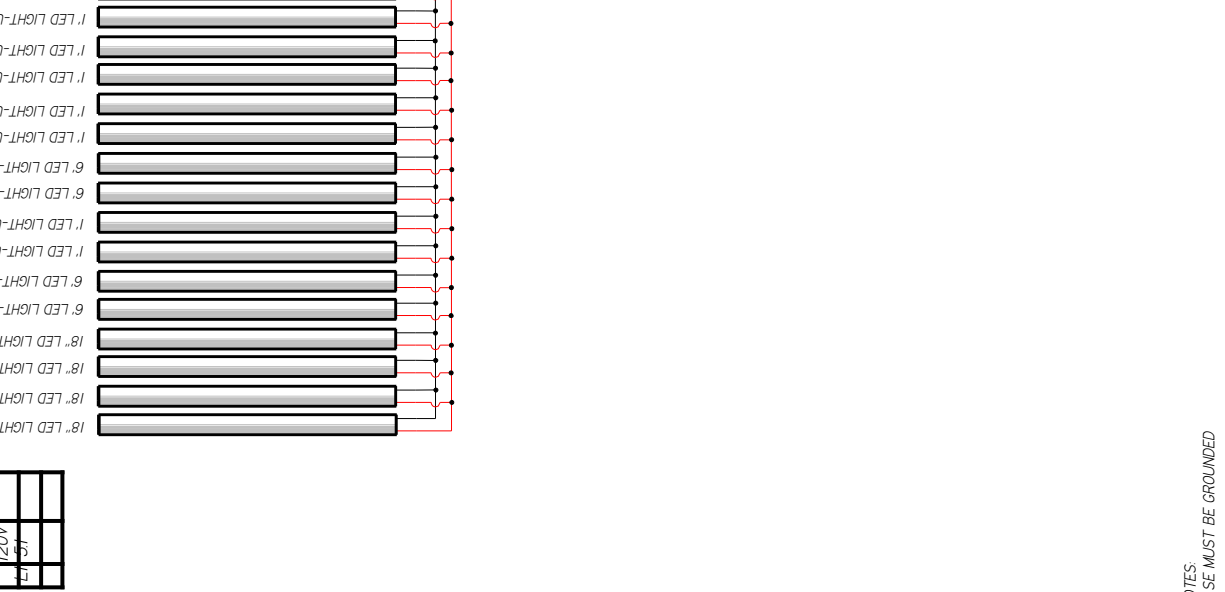
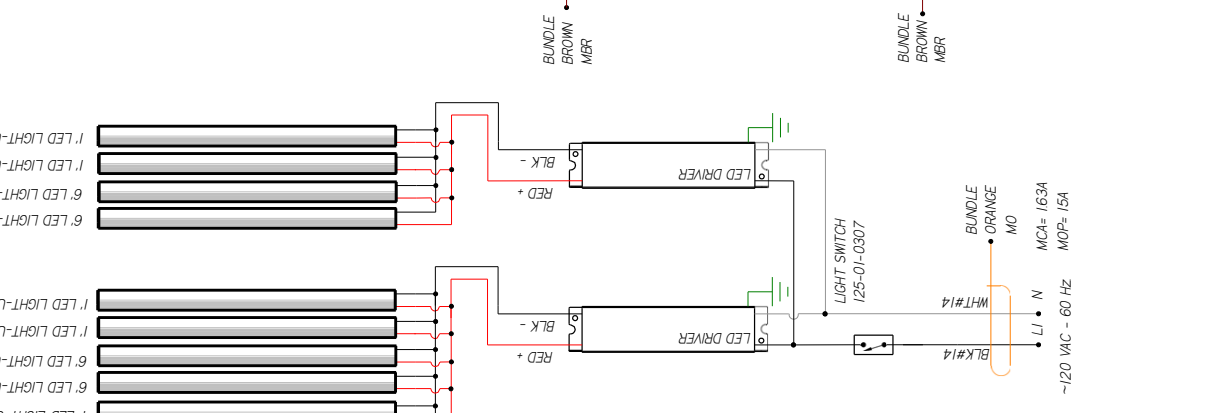
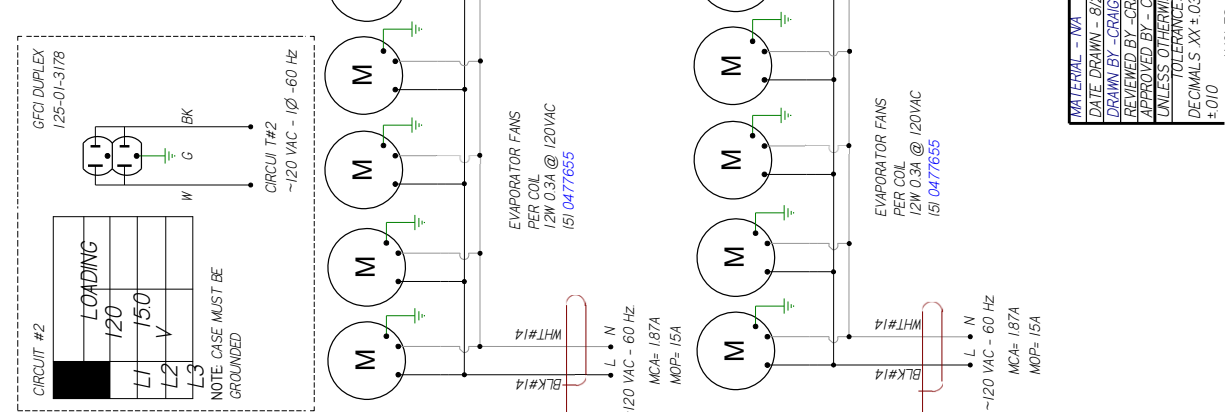
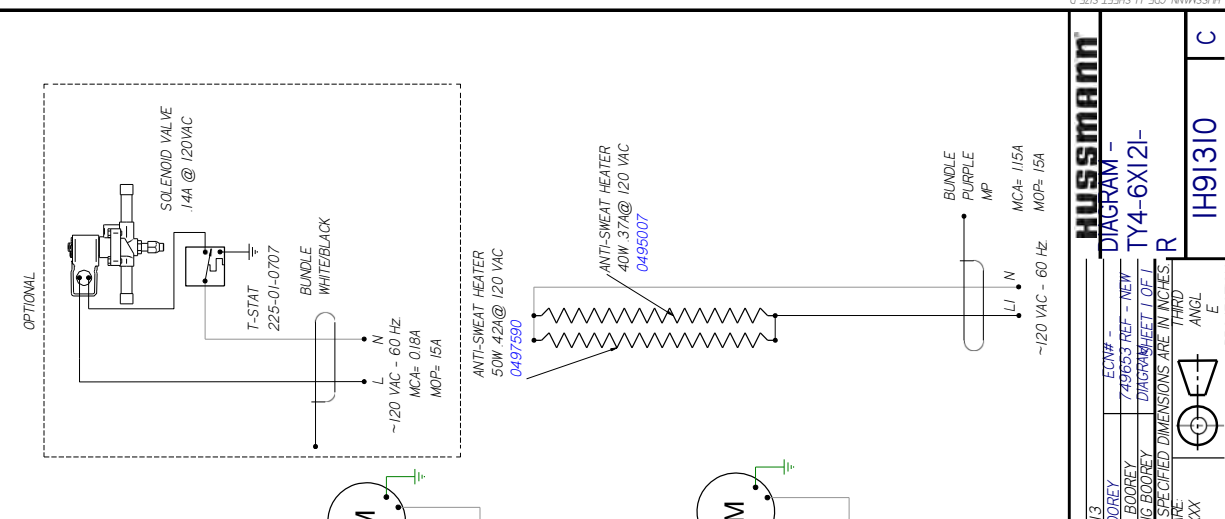

**MATERIAL - NA**

DATE DRAWN - 8/27/13

DRAWN BY - CRAIG BOOREY

REVIEWED BY - CRAIG BOOREY

APPROVED BY - CRAIG BOOREY

UNLESS OTHERWISE SPECIFIED DIMENSIONS ARE IN INCHES

TOLERANCES ARE:

DECIMALS .XX ±0.3 .XXX ±0.0

ANGLES ± 2°

PROJECTION

ANGLES

THIRD

ECN# - 749603 REF - NEW

DIAGRAM - TY4-6X12-

ECN# - 749603 REF - NEW

DIAGRAM - TY4-6X12-

**HUSSMANN**

**DIAGRAM - TY4-6X12-**

**IH91310**

**C**

NOTES:

CASE MUST BE GROUNDED









OPTIONAL LEDGE LIGHTS

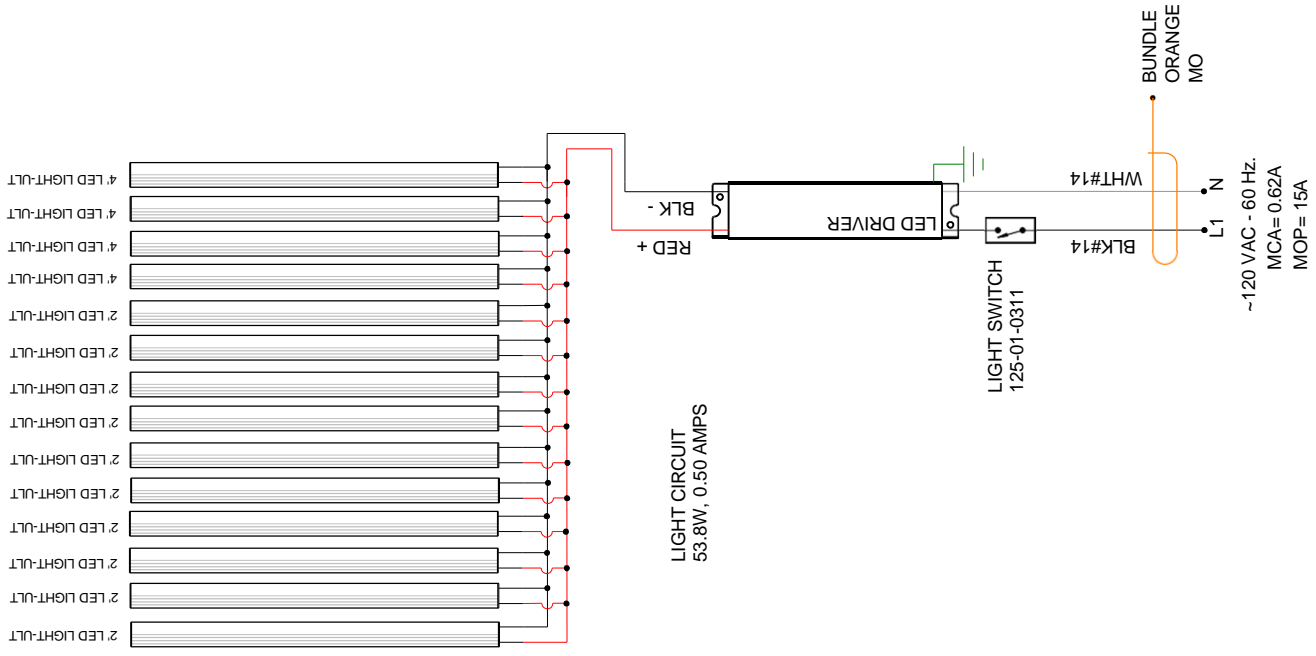

| CIRCUIT #2 | LOADING |
|------------|---------|
|            | 120 V   |
| L1         | 15.0    |
| L2         |         |
| L3         |         |

GFCI DUPLEX 125-01-3178

**NOTE: CASE MUST BE GROUNDED**

CIRCUIT #2  
~120 VAC - 1Ø - 60 Hz

| REVISIONS: | DESCRIPTION:                                | DATE:   | BY: | CHECKED BY:             | DATE: |
|------------|---|---------|-----|-------------------------|-------|
| A          | CNF#696786                                  | 2/27/13 | CB  | PRODUCTION ORDER #27433 |       |
| B          | ECN-COD-0015284 ADDED OPTIONAL LEDGE LIGHTS | 4/11/22 | CB  | FILE LOCATION:          |       |

PROJECT TITLE: **TY4-CASE**  
 DRAWING TITLE: **DIAGRAM-TY4-6X141-R ISLAND**

| REVISION HISTORY       |                | REV BY     | CHKD BY | APPR BY |
|------------------------|----------------|------------|---------|---------|
| 1                      | ECN-CAP-000957 | 2007/01/06 | CB      | CB      |
| REVISION DESCRIPTION   |                | REV BY     | CHKD BY | APPR BY |
| RELEASED TO PRODUCTION |                | CB         | CB      | CB      |

| CIRCUIT #1 | LOADING |
|------------|---------|
| 120V       |         |
| L1         | 6.8     |
| L2         |         |
| L3         |         |

| CIRCUIT #2 | LOADING |
|------------|---------|
| 120 V      |         |
| L1         | 15.0    |
| L2         |         |
| L3         |         |

NOTE: CASE MUST BE GROUNDED

GFCI DUPLEX 125-01-3178

CIRCUIT #2  
~120 VAC - 1Ø - 60 HZ

1ST, 2ND & 3RD ROW OF SHELVES, 1/2 SIDE

1ST, 2ND & 3RD ROW OF SHELVES, 1/2 SIDE

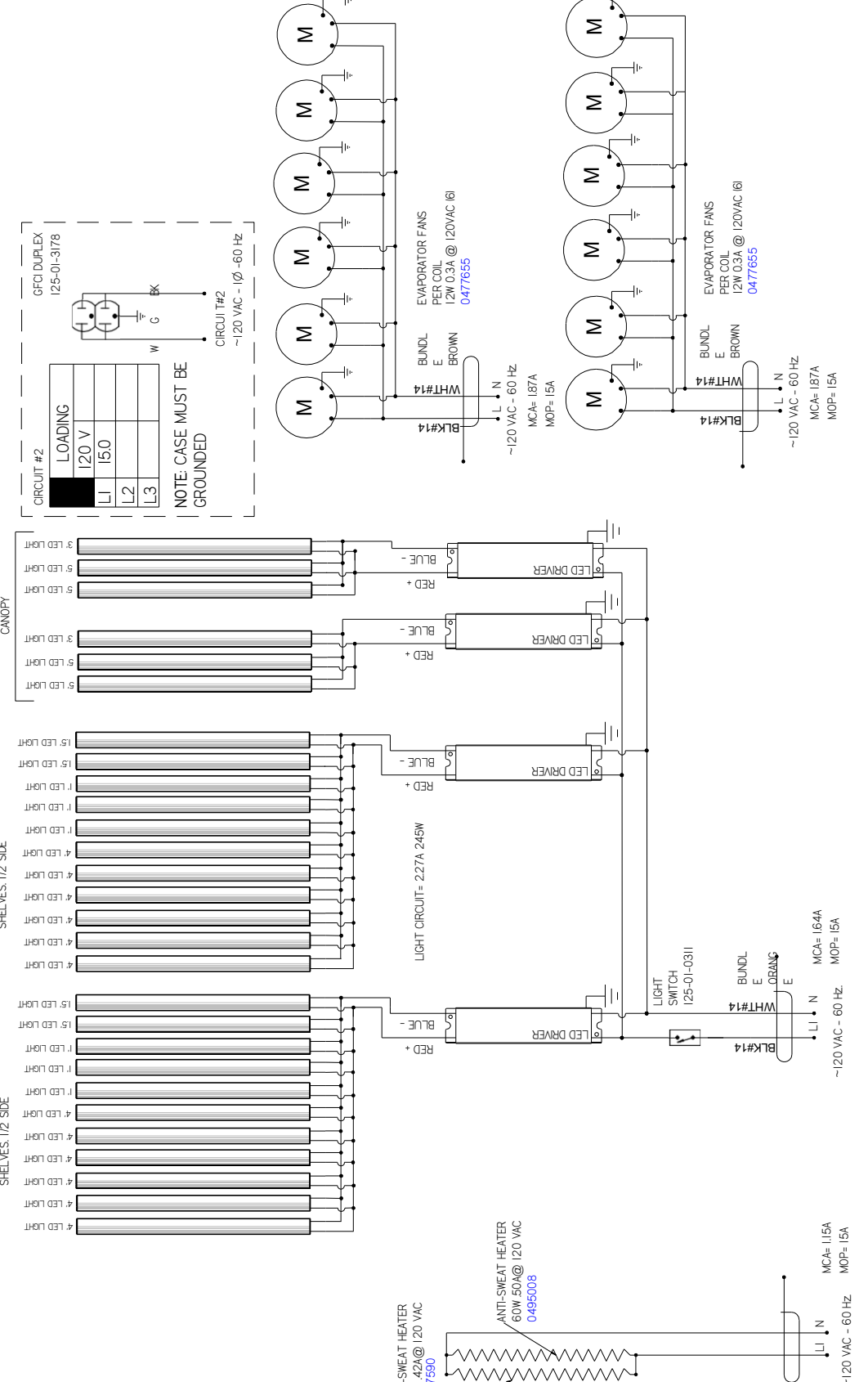

ANTI-SWEAT HEATER 50W 42A@120 VAC 0497590

ANTI-SWEAT HEATER 60W 50A@120 VAC 0495008

LED DRIVER

LED DRIVER

LED DRIVER

LED DRIVER

LED DRIVER

LED DRIVER

LED DRIVER

LED DRIVER

LED DRIVER

LED DRIVER

LED DRIVER

LED DRIVER

LED DRIVER

LED DRIVER

LED DRIVER

LED DRIVER

LED DRIVER

LED DRIVER

LED DRIVER

LED DRIVER

LED DRIVER

LED DRIVER

LED DRIVER

LED DRIVER

LED DRIVER

LED DRIVER

LED DRIVER

LED DRIVER

LED DRIVER

LED DRIVER

LED DRIVER

LED DRIVER

LED DRIVER

LED DRIVER

LED DRIVER

LED DRIVER

LED DRIVER

LED DRIVER

LED DRIVER

LED DRIVER

LED DRIVER

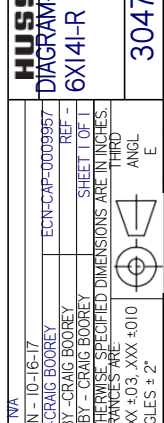

EVAPORATOR FANS PER COIL 12W 0.3A @ 120VAC (I) 0477655

EVAPORATOR FANS PER COIL 12W 0.3A @ 120VAC (I) 0477655

EVAPORATOR FANS PER COIL 12W 0.3A @ 120VAC (I) 0477655

EVAPORATOR FANS PER COIL 12W 0.3A @ 120VAC (I) 0477655

EVAPORATOR FANS PER COIL 12W 0.3A @ 120VAC (I) 0477655

EVAPORATOR FANS PER COIL 12W 0.3A @ 120VAC (I) 0477655

EVAPORATOR FANS PER COIL 12W 0.3A @ 120VAC (I) 0477655

NOTE: CASE MUST BE GROUNDED WHEN PASSING WIRES THROUGH METAL HOLES A GROMMET MUST BE USED

|   |                       |                |
|---|-----------------------|----------------|
| MATERIAL - NA   | DATE DRAWN - 10-16-17 | ECN-CAP-000957 |
| DRAWN BY - CRAIG BOOREY   | REV BY - CRAIG BOOREY | REF -          |
| APPROVED BY - CRAIG BOOREY  | SHEET 1 OF 1          | THIRD          |
| UNLESS OTHERWISE SPECIFIED DIMENSIONS ARE IN INCHES TOLERANCES ARE: |                       |                |
| DECIMALS .XX ±0.3 .XXX ±0.10  | ANGL                  | E              |
| ANGLES ± 2°   | PRODUCTION            |                |

3047157 A

HUSSMANN-FY4ECRC-6X141-R

LIGHT CIRCUIT= 2.02A 218.2W

BOTTOM SHELF

MID SHELF

TOP SHELF

CANOPY LIGHTS

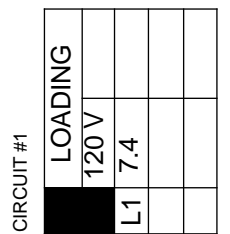
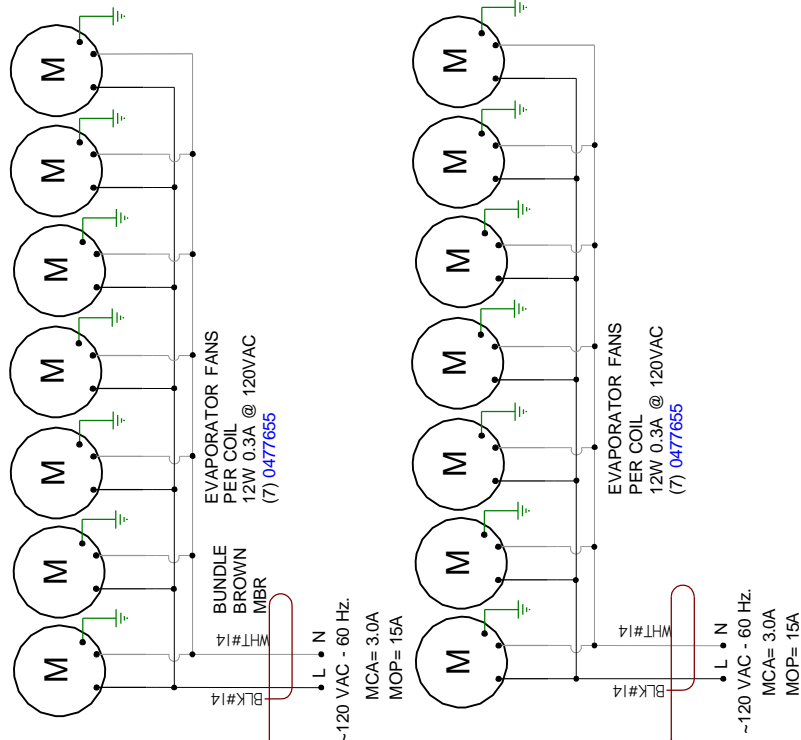
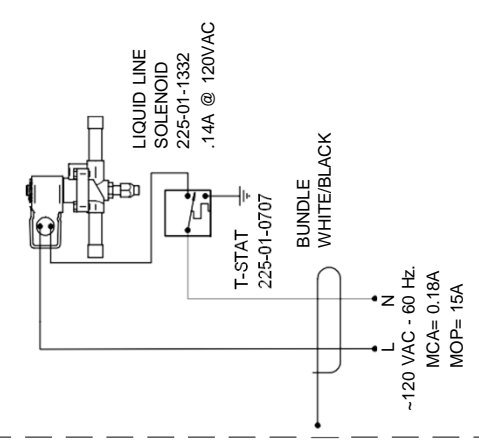
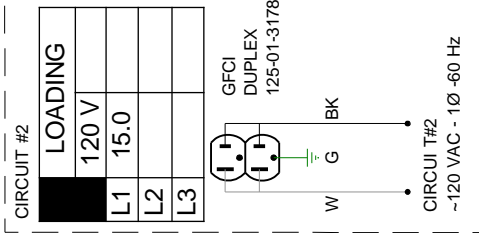
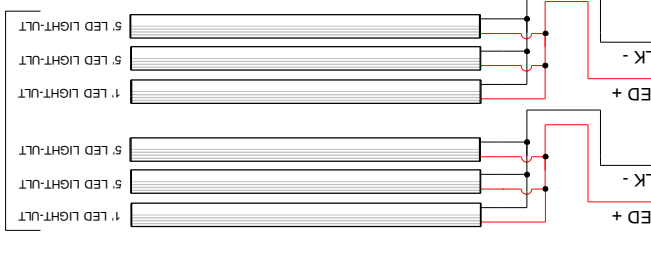
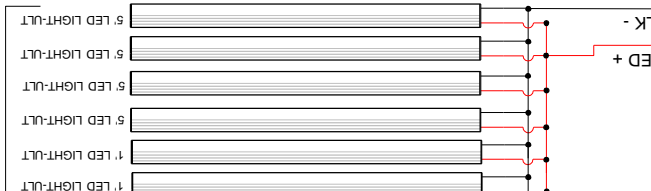
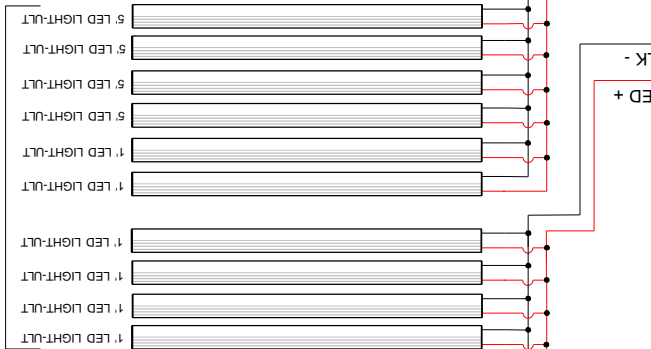
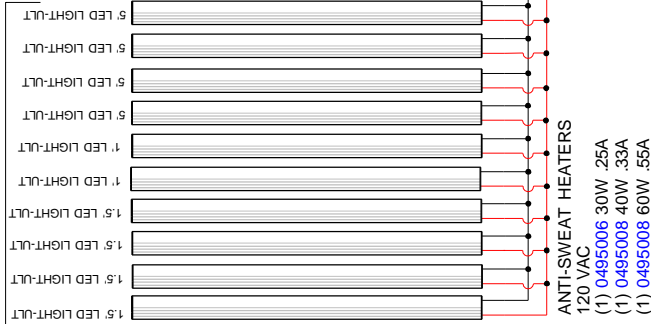

**NOTE: CASE MUST BE GROUNDED**

|            |                        |                         |                            |
|------------|------------------------|-------------------------|----------------------------|
| REVISIONS: | DRAWN BY: CRAIG BOOREY | PROJECT TITLE: TY4-CASE | DRAWING #: 1H85195         |
| #:         | CHECKED BY:            | DATE: 3/25/13           |                            |
| A          | 3/25/13                | CB                      | PRODUCTION ORDER #: 632101 |
| B          | 4/21/15                | CB                      | FILE LOCATION:             |
| C          | 5/3/22                 | CB                      |                            |



| REVISION HISTORY |                 | DATE    | REVISION DESCRIPTION   | REV BY | CHKD BY | APPR BY |
|------------------|-----------------|---------|------------------------|--------|---------|---------|
| REV              | ECN             |         |                        |        |         |         |
| A                | ECN-COD-0015266 | 1-13-22 | RELEASED TO PRODUCTION | CB     | CB      | CB      |

| CIRCUIT #1 | LOADING |
|------------|---------|
|            | 120 V   |
|            | 10.4    |

LIGHT CIRCUIT = 4.2A 452.6W

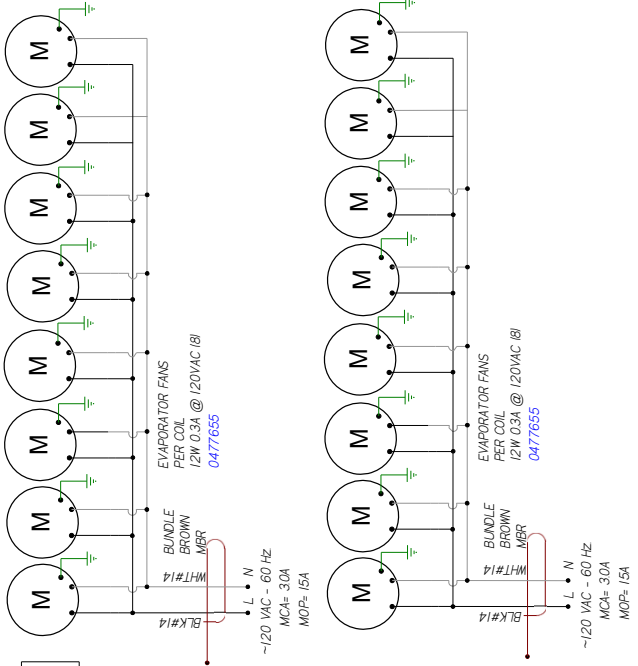
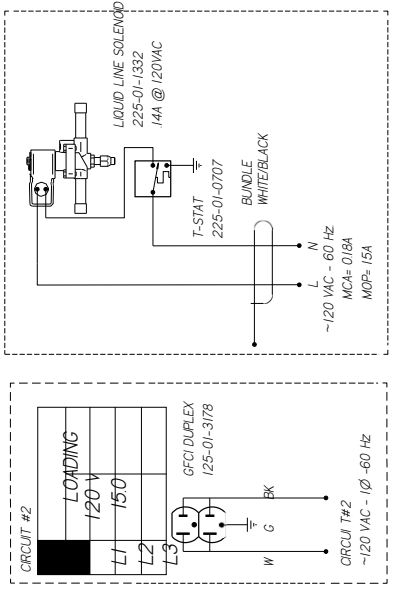
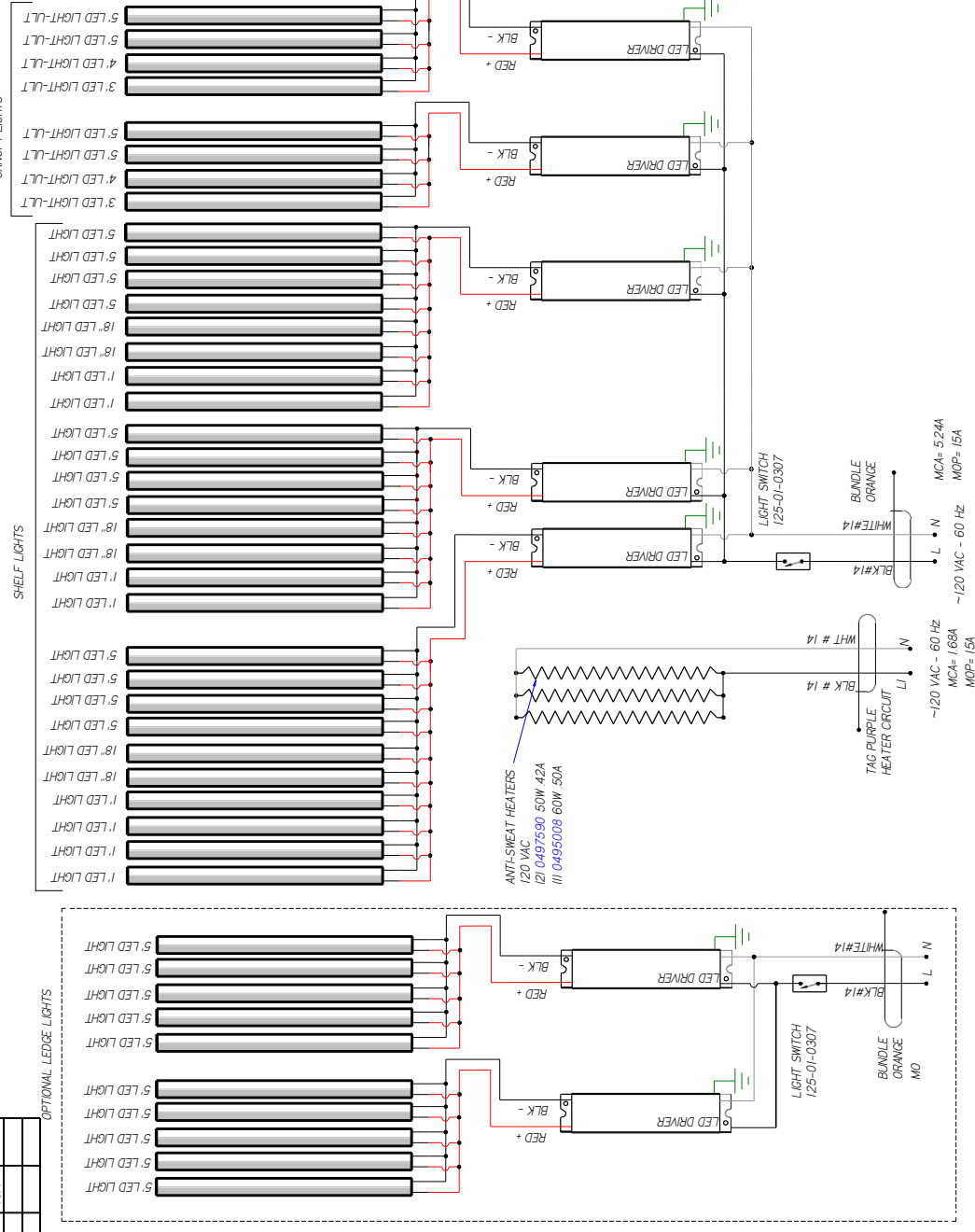

**WIRE MARKER COLORS/ABBREVIATIONS**

|                  |               |
|------------------|---------------|
| BLACK = MBK      | MAROON =      |
| BLUE = MBL       | MWR ORANGE =  |
| BROWN = MBR      | MG PINK = MFI |
| DARK BLUE =      | PURPLE = MP   |
| MOB GREEN = MG   | RED = MR      |
| LIGHT BLUE = MLB | YELLOW = MYL  |

**UL COLOR CODES / ABBREVIATIONS**

|             |             |
|-------------|-------------|
| RED = RD    | WHITE = WT  |
| BLACK = BK  | GREEN = GN  |
| BLUE = BL   | BROWN = BN  |
| YELLOW = YL | ORANGE = OR |
| GRAY =      | OR VIOLET = |
| GY          | VT          |

**HUSSMANN**  
**DIAGRAM-**  
**TY4ECRC-6X181-R**

FACTORY 14GA WIRE  
 \_FACTORY 10GA WIRE  
 \_ \_ \_ \_ \_ FIELD WIRE  
 \_ \_ \_ \_ \_ DO NOT SCALE DRAWING  
 SHEET 1 OF 1

- NOTES:**
1. PRINTED DOCUMENT REQUIRED SETTING. ALL COLORS BLACK & WHITE
  2. CASE & ANY REMOVABLE PANEL WITH ELECTRICAL PARTS MUST BE GROUNDED.
  3. WHEN PASSING WIRES THROUGH METAL HOLES A GROMMET MUST BE USED

BOTTOM SHELF  
MID SHELF  
TOP SHELF

ANTI-SWEAT HEATERS  
120 VAC  
(1) 0497590 50W / 42A  
(1) 0495007 40W / 33A  
(1) 0495008 60W / 50A

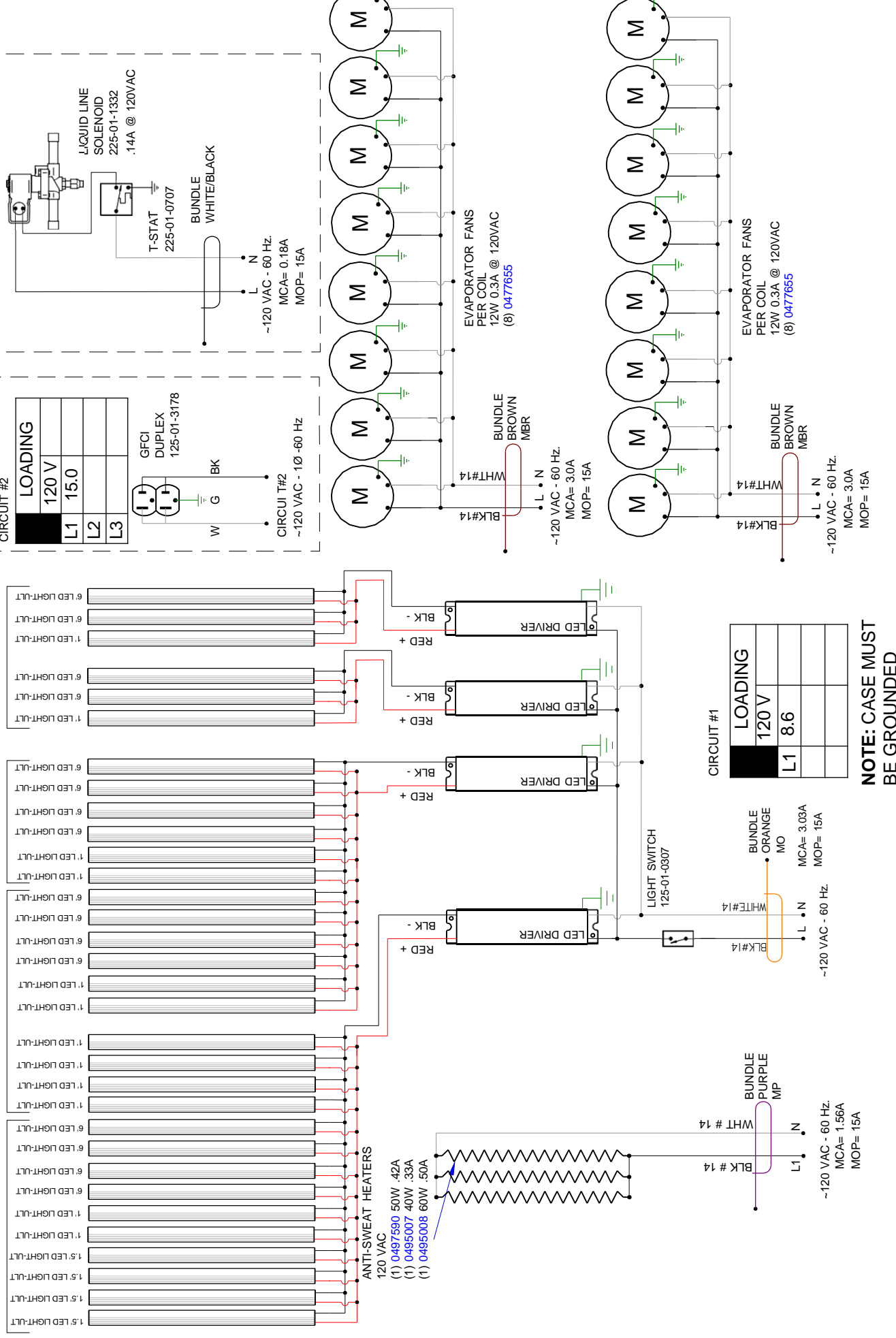

CIRCUIT #2

| LOADING | 120 V |
|---------|-------|
| L1      | 15.0  |
| L2      |       |
| L3      |       |

CIRCUIT #1

| LOADING | 120 V |
|---------|-------|
| L1      | 8.6   |
| L2      |       |
| L3      |       |

OPTIONAL

| LOADING | 120 V |
|---------|-------|
| L1      | 15.0  |
| L2      |       |
| L3      |       |

EVAPORATOR FANS PER COIL

| LOADING | 120 V |
|---------|-------|
| L1      | 0.3A  |
| L2      |       |
| L3      |       |

EVAPORATOR FANS PER COIL

| LOADING | 120 V |
|---------|-------|
| L1      | 0.3A  |
| L2      |       |
| L3      |       |

ANTI-SWEAT HEATERS

| LOADING | 120 V |
|---------|-------|
| L1      | 1.56A |
| L2      |       |
| L3      |       |

**HUSSMANN**  
Hussmann Corporation, Intl.  
13770 Ramona Avenue  
Chino, CA. 91710  
(909)-590-4910 Lic.#: 644406

REVISIONS:  
# DESCRIPTION:  
B CN#696786 Added Fans & AS Heaters  
C CN#980241 Changed Anti-Sweat heater  
D ECN-COD-0015289 New Lights

DRAWN BY: CRAIG BOOREY  
CHECKED BY: [ ]  
DATE: 8/7/12  
DATE: 3/21/13  
DATE: 4/21/15  
DATE: 5/3/22

BY: CB CB CB  
FILE LOCATION:

PROJECT TITLE: TY4-CASE  
DRAWING TITLE: DIAGRAM-TY4-6X18-R

DRAWING #: 1H77863  
PRODUCTION ORDER #: 920172

NOTE: CASE MUST BE GROUNDED

## User Information

### Stocking

Improper temperature and lighting will cause serious product loss. Discoloration, dehydration and spoilage can be controlled with proper use of the equipment and handling of product. Product temperature should always be maintained at a constant and proper temperature. This means that from the time the product is received, through storage, preparation and display, the temperature of the product must be controlled to maximize life of the product. Hussmann cases were not designed to “heat up” or “cool down” product - but rather to maintain an item’s proper temperature for maximum shelf life. To achieve the protection required always:

1. Minimize processing time to avoid damaging temperature rise to the product. Product should be at proper temperature.
2. Keep the air in and around the case area free of foreign gasses and fumes or food will rapidly deteriorate.
3. Maintain the display merchandisers temperature controls as outlined in the refrigerator section of this manual.
4. Do not place any product into these refrigerators until all controls have been adjusted and they are operating at the proper temperature. Allow merchandiser to operate a minimum of one (1) hour before stocking with any product.
5. When stocking, never allow the product to extend beyond the recommended load limit. Air discharge and return air fl ue must be unobstructed at all times to provide proper refrigeration.
6. Avoid the use of supplemental fl ood or spot lighting. Display light intensity has been designed for maximum visibility and product life at the factory. The use of higher output fl uorescent lamps (H.O. and V.H.O.), will shorten the shelf life of the product.

### Case Cleaning

Long life and satisfactory performance of any equipment are dependent upon the care given to it. To insure long life, proper sanitation and minimum maintenance costs, the refrigerator should be thoroughly cleaned frequently. SHUT OFF FAN DURING CLEANING PROCESS. It can be unplugged within the case, or shut off entire case at the source. The interior bottom may be cleaned with any domestic soap or detergent based cleaners. Sanitizing solutions will not harm the interior bottom, however, these solutions should always be used according to the Hussmann’s directions. It is essential to establish and regulate cleaning procedures. This will minimize bacteria causing discoloration which leads

to degraded product appearance and significantly shortening product shelf life.

Soap and hot water are not enough to kill this bacteria. A sanitizing solution must be included with each cleaning process to eliminate this bacteria.

1. Scrub thoroughly, cleaning all surfaces, with soap and hot water.
2. Rinse with hot water, but do not flood.
3. Apply the sanitizing solution according to Hussmann’s directions.
4. Rinse thoroughly.
5. Dry completely before resuming operation.

### Plexiglass and Acrylic Care

Improper cleaning not only accelerates the cleaning cycle but also degrades the quality of this surface. Normal daily buffing motions can generated static cling attracting dust to the surface. Incorrect cleaning agents or cleaning cloths can cause micro scratching of the surface, causing the plastic to haze over time.

### Cleaning

Hussmann recommends using a clean damp chamois, or a paper towel marked as “dust and abrasive free” with 210® Plastic Cleaner and Polish available by calling Sumner Labs at 1-800-542-8656. Hard, rough cloths or paper towels will scratch the acrylic and should not be used.

## Troubleshooting

### Troubleshooting Guide

| Problem   | Possible Cause  | Possible Solution   |
|---|---|---|
| <b>Case temperature is too warm.</b>                    | Ambient conditions may be affecting the case operation.                                   | Check case position in store. Is the case located near an open door, window, electric fan or air conditioning vent that may cause air currents? See page 5 for details. Provide shading for the case or move out of direct sunlight. Move the case away from or block air ventilation currents aimed directly at the case. Case must be located minimum 15 Ft away from doors or windows. Cases are designed to operate at 55% Relative humidity and a temperature of 75°F. |
|   | Discharge air temp is out of spec.  | Check evaporator fan operation. Check electrical connections and input voltage.   |
|   |   | Fans are installed backwards. Check airflow direction.  |
|   |   | Fan blades are installed incorrectly. Make sure fan blades have correct pitch and are per specification.  |
|   |   | Check to see that fan plenum is installed correctly. It should not have any gaps.   |
|   | Check suction pressure and insure that it meets factory specifications.                   |   |
|   | Case is in defrost.   | Check defrost settings. See Technical Specifications section.   |
|   | Product load may be over its limits blocking airflow.                                     | Redistribute product so it does not exceed load level. There is a sticker on the inside of the case indicating what the maximum load line is.   |
| Coil is freezing over.                                  | Return air is blocked, make sure debris is not blocking the intake section.               |   |
|   | Coil close-offs are not installed. Inspect coil to make sure these parts are on the case. |   |
| Condensing coil or evaporator coil is clogged or dirty. | Clean coil.   |   |
| <b>Case temperature is too cold.</b>                    | The t-stat temp is set too low.   | Check settings. See Technical Specifications section.   |
|   | Ambient conditions may be affecting the case operation.                                   | Check case position in store. Is the case located near an open door, window, electric fan or air conditioning vent that may cause air currents? See page 5 for details. Provide shading for the case or move out of direct sunlight. Move the case away from or block air ventilation currents aimed directly at the case. Case must be located minimum 15 Ft away from doors or windows. Cases are designed to operate at 55% Relative humidity and a temperature of 75°F. |
| <b>Condensation on glass.</b>                           | Ambient conditions may be affecting the case operation.                                   | Check case position in store. Is the case located near an open door, window, electric fan or air conditioning vent that may cause air currents? Case must be located minimum 15 Ft away from doors or windows. Cases are designed to operate at 55% Relative humidity and a temperature of 75°F.  |
|   | Inadequate air circulation.   | Check if air sweep fans are functioning, check electrical connections.  |
|   | There is not enough heat provided in the airflow.   | Check if air sweep heater is functioning, check electrical connections.   |
|   | There are glass gaps on the side of the case.   | See glass adjustment section.   |
|   | Glass is not completely shut.   | Close glass correctly.  |

## Troubleshooting

| Problem                                 | Possible Cause  | Possible Solution  |
|---|---|--|
| <b>Water has pooled under case.</b>     | Case drain is clogged.  | Clear drain.   |
|   | PVC drains under case may have a leak.                                  | Repair as needed.  |
|   | Case tub has unsealed opening.  | Seal as needed.  |
|   | If the case is in a line-up, case to case joint is missing or unsealed. | Install case to case joint and seal as needed.   |
|   | Evaporator pan is overflowing (if applicable).                          | Check electrical connection to evaporator pan. Check float assembly, it should move freely up and down the support stem. Clear any debris. |
| <b>Case is not draining properly.</b>   | Case is not level.  | Level the case.  |
|   | Drain screen is plugged.  | Clean drain screen and remove any debris.  |
|   | Drain or P-trap is clogged.   | Clear any debris.  |
| <b>Frost or ice on evaporator coil.</b> | Evaporator fans are not functioning.                                    | Check electrical connections.  |
|   | Defrost clock is not functioning.                                       | Case should be serviced by a qualified service technician.   |
|   | Coil is freezing over.  | Return air is blocked, make sure debris is not blocking the intake section.  |
|   |   | Coil close-offs are not installed. Inspect coil to make sure these parts are on the case.  |
| <b>Lights do not come on.</b>           | LED Driver/light socket wiring.   | Check electrical connections. See Electrical Section and check wiring diagram.   |
|   | LED Driver needs to be replaced.  | Case should be serviced by a qualified service technician. See Electrical Section.   |
|   | Lamp socket needs to be replaced.                                       | Case should be serviced by a qualified service technician.   |
|   | Lamp needs to be replaced.  | See Maintenance Section.   |
|   | Light Switch needs to be replaced.                                      | Case should be serviced by a qualified service technician.   |

## Appendix A. - Temperature Guidelines

The refrigerators should be operated according to the manufacturer's published engineering specifications for entering air temperatures for specific equipment applications. Table 1 shows the typical temperature of the air entering the food zone one hour before the start of defrost and one hour after defrost for various categories of refrigerators. Refer to Appendix C for Field Evaluation Guidelines.

| Type of Refrigerator      | Typical Entering Air Temperature |
|---------------------------|----------------------------------|
| <b>I. OPEN DISPLAY</b>    |                                  |
| A. Non frozen:            |                                  |
| 1) Meat                   | 28°F                             |
| 2) Dairy/Deli             | 32°F                             |
| 3) Produce                |                                  |
| a. Processed              | 36°F                             |
| b. Unprocessed            | 45°F                             |
| B. Frozen                 | 0°F                              |
| C. Ice Cream              | -5°F                             |
| <b>II. CLOSED DISPLAY</b> |                                  |
| A. Non frozen:            |                                  |
| 1) Meat                   | 34°F                             |
| 2) Dairy/Deli             | 34°F                             |
| 3) Produce                |                                  |
| a. Processed              | 36°F                             |
| b. Unprocessed            | 45°F                             |
| B. Frozen                 | 0°F                              |
| C. Ice Cream              | -5°F                             |

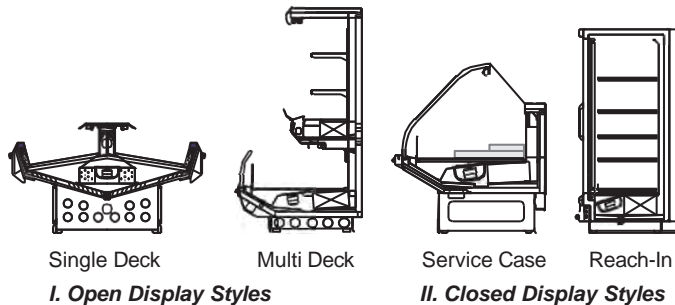

## Appendix B. - Application Recommendations

1. Temperature performance is critical for controlling bacteria growth. Therefore, the following recommendations are included in the standard. They are based on confirmed field experience over many years.
2. The installer is responsible for following the installation instructions and recommendations provided by Hussmann for the installation of each individual type refrigerator.
3. Refrigeration piping should be sized according to the equipment manufacturer's recommendations and installed in accordance with normal refrigeration practices. Refrigeration piping should be insulated according to Hussmann's recommendations.

3. A clogged waste outlet blocks refrigeration. The installer is responsible for the proper installation of the system which dispenses condensate waste through an air gap into the building indirect waste system.
4. The installer should perform a complete start-up evaluation prior to the loading of food into the refrigerator, which includes such items as:
  - a) Initial temperature performance, Coils should be properly fed with a refrigerant according to manufacturer's recommendations.
  - b) Observation of outside influences such as drafts, radiant heating from the ceiling and from lamps. Such influence should be properly corrected or compensated for.
  - c) At the same time, checks should be made of the store dry-bulb and wet-bulb temperatures to ascertain that they are within the limits prescribed by Hussmann.
  - d) Complete start-up procedures should include checking through a defrost to make certain of its adequate frequency and length without substantially exceeding the actual needs. This should include checking the electrical or refrigerant circuits to make sure that defrosts are correctly programmed for all the refrigerators connected to each refrigeration system.
  - e) Recording instruments should be used to check performance.

## Appendix C. - Field Recommendations

Recommendations for field evaluating the performance of retail food refrigerators and hot cases

- 1.0 The most consistent indicator of display refrigerator performance is temperature of the air entering the product zone (see Appendix A). In practical use, the precise determination of return air temperature is extremely difficult. Readings of return air temperatures will be variable and results will be inconsistent. The product temperature alone is not an indicator of refrigerator performance.

**NOTE:** Public Health will use the temperature of the product in determining if the refrigerator will be allowed to display potentially hazardous food. For the purpose of this evaluation, product temperature above the FDA Food Code 1993 temperature for potentially hazardous food will be the first indication that an evaluation should be performed. It is expected that all refrigerators will keep food at the FDA Food Code 1993 temperature for potentially hazardous food.

- 1.1 The following recommendations are made for the purpose of arriving at easily taken and understood data which, coupled with other observations, may be used to determine whether a display refrigerator is working as intended:
- a) **INSTRUMENT** - A stainless steel stem-type thermometer is recommended and it should have a dial a minimum of 1 inch internal diameter. A test thermometer scaled only in Celsius or dually scaled in Celsius and Fahrenheit shall be accurate to 1°C (1.8°F). Temperature measuring devices that are scaled only in Fahrenheit shall be accurate to 2°F. The thermometer should be checked for proper calibration. (It should read 32°F when the stem is immersed in an ice water bath).
  - b) **LOCATION** - The probe or sensing element of the thermometer should be located in the airstream where the air first enters the display or storage area, and not more than 1 inch away from the surface and in the center of the discharge opening.
  - c) **READING** - It should first be determined that the refrigerator is refrigerating and has operated at least one hour since the end of the last defrost period. The thermometer reading should be made only after it has been allowed to stabilize, i.e., maintain a constant reading.
  - d) **OTHER OBSERVATIONS** - Other observations should be made which may indicate operating problems, such as unsatisfactory product, feel/appearance.
  - e) **CONCLUSIONS** - In the absence of any apparent undesirable conditions, the refrigerator should be judged to be operating properly. If it is determined that such condition is undesirable, i.e., the product is above proper temperature, checks should be made for the following:
    1. Has the refrigerator been loaded with warm product?
    2. Is the product loaded beyond the "Safe Load Line" markers?
    3. Are the return air ducts blocked?
    4. Are the entering air ducts blocked?
    5. Is a dumped display causing turbulent air flow and mixing with room air?
    6. Are spotlights or other high intensity lighting directed onto the product?
    7. Are there unusual draft conditions (from heating/air-conditioning ducts, open doors, etc.)?
    8. Is there exposure to direct sunlight?
    9. Are display signs blocking or diverting airflow?

10. Are the coils of the refrigerator iced up?
11. Is the store ambient over 75°F, 55% RH as set forth in ASHRAE Standard 72 and ASHRAE Standard 117?
12. Are the shelf positions, number, and size other than recommended by Hussmann?
13. Is there an improper application or control system?
14. Is the evaporator fan motor/blade inoperative?
15. Is the defrost time excessive?
16. Is the defrost termination, thermostat (if used) set too high?
17. Are the refrigerant controls incorrectly adjusted?
18. Is the air entering the condenser above design conditions? Are the condenser fins clear of dirt, dust, etc.?
19. Is there a shortage of refrigerant?
20. Has the equipment been modified to use replacements for CFC-12, CFC-502 or other refrigerant? If so, have the modifications been made in accordance with the recommendations of the equipment manufacturer? Is the refrigerator charged with the proper refrigerant and lubricant? Does the system use the recommended compressor?

## Appendix D. - Recommendations to User

- 1.0 Hussmann Corporation provides instructions and recommendations for proper periodic cleaning. The user will be responsible for such cleaning, including the cleaning of low temperature equipment within the compartment and the cooling coil area(s). Cleaning practices, particularly with respect to proper refrigerator unloading and warm-up, must be in accordance with applicable recommendations.
1. Cleaning of non frozen food equipment should include a weekly cleaning of the food compartment as a minimum to prevent bacteria growth from accumulating. Actual use and products may dictate more frequent cleaning. Circumstances of use and equipment design must also dictate the frequency of cleaning the display areas. Weekly washing down of the storage compartment is also recommended, especially for equipment subject to drippage of milk or other liquids, or the collection of vegetable, meat, crumbs, etc. or other debris or litter. Daily cleaning of the external areas surrounding the storage or display compartments with detergent and water will keep the equipment presentable and prevent grime buildup.
  2. Load levels as defined by the manufacturer must be observed.

1.3 The best preservation is achieved by following these rules:

- a) Buy quality products.
- b) Receive perishables from transit equipment at the ideal temperature for the particular product.
- c) Expedite perishables to the store's storage equipment to avoid unnecessary warm-up and prolonged temperature recovery. Food store refrigerators are not food chillers nor can they reclaim quality lost through previous mishandling.
- d) Care must be taken when cross merchandising products to ensure that potentially hazardous vegetable products are not placed in non refrigerated areas.
- e) Display and storage equipment doors should be kept closed during periods of inactivity.
- f) Minimize the transfer time of perishables from storage to display.
- g) Keep meat under refrigeration in meat cutting and processing area except for the few moments it is being handled in processing. When a cut or tray of meat is not to be worked on immediately, the procedure should call for returning it to refrigeration.
- h) Keep tools clean and sanitized. Since mechanical equipment is used for fresh meat processing, all such equipment should be cleaned at least daily and each time a different kind of meat product comes in contact with the tool or equipment.
- i) Make sure that all refrigeration equipment is installed and adjusted in strict accordance with the manufacturer's recommendations.
- j) See that all storage and refrigeration equipment is kept in proper working order by routine maintenance.



---

This warning does not mean that Hussmann products will cause cancer or reproductive harm, or is in violation of any product-safety standards or requirements. As clarified by the California State government, Proposition 65 can be considered more of a ‘right to know’ law than a pure product safety law. When used as designed, Hussmann believes that our products are not harmful. We provide the Proposition 65 warning to stay in compliance with California State law. It is your responsibility to provide accurate Proposition 65 warning labels to your customers when necessary. For more information on Proposition 65, please visit the California State government website.

---

### Service Record

Last service date:      By:

|       |       |
|-------|-------|
| _____ | _____ |
| _____ | _____ |
| _____ | _____ |
| _____ | _____ |
| _____ | _____ |
| _____ | _____ |
| _____ | _____ |

---

## **HUSSMANN®/Chino**

Additional copies of this publication may be obtained by contacting:

Hussmann® Chino  
13770 Ramona Avenue • Chino, California 91710  
(909) 628-8942 FAX  
(909) 590-4910  
(800) 395-9229

[www.hussmann.com](http://www.hussmann.com)

|  |
|--|
| The <i>MODEL NAME</i> and <i>SERIAL NUMBER</i> is required in order to provide you with the correct parts and information for your particular unit.<br>They can be found on a small metal plate on the unit.<br>Please note them below for future reference. |
| <b>MODEL:</b>  |
| <b>SERIAL NUMBER:</b>  |