

**HUSSMANN®/CHINO**

Installation  
& Operation  
Manual

**TY3, TY4 ISLAND CASE**  
**(ENTYCE)**

REV. 1125

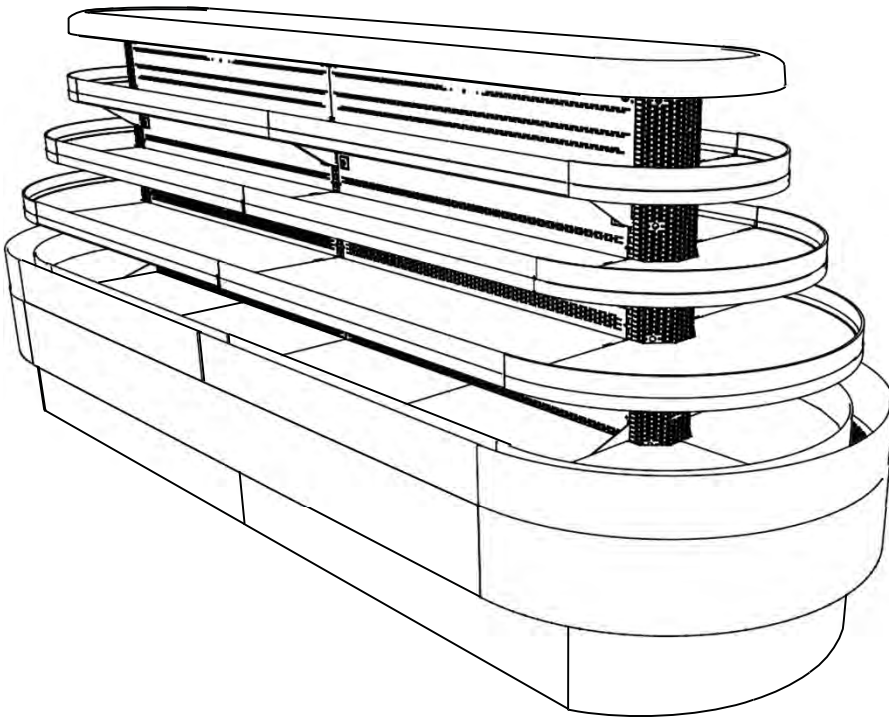

**TY3, TY4**  
**(ENTYCE)**  
**ISLAND CASE**

# Table of Contents

Warning	4
General Information	6
Cut and Plan Views	7
Installation	9
Plumbing	11
Refrigeration Piping	12
Sump Pump Configuration	13
Specifications	15
Electrical	18
Wiring Diagrams Index	19
Wiring Diagrams	21
User Information	75
Troubleshooting	76
Appendix	78



# WARNING

1. Do Not Push, Pull, Adjust, or Manipulate the TY case by any glass component.
  - Doing so will result in severe damage to such components
  - Glass breakage may result in serious injury
2. Never stand on the TY Top, Deck, or any Shelves for any reason.
  - Misusing these surfaces as steps will result in damage to the case
  - Misusing these surfaces as steps may result in serious injury to the user
  - These surfaces are intended for the storage and merchandising of food products
  - Use a ladder or designed structure to work above the case (Do not lean on case)
3. DO NOT remove shelves. WARNING! will adversely impact case performance when merchandising.

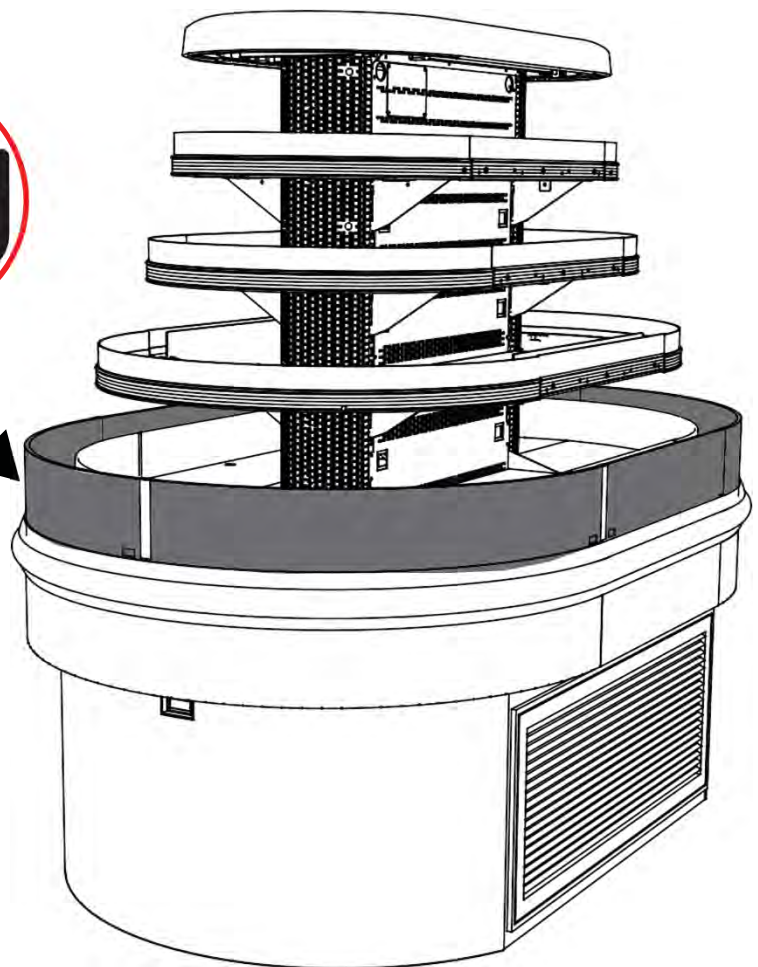
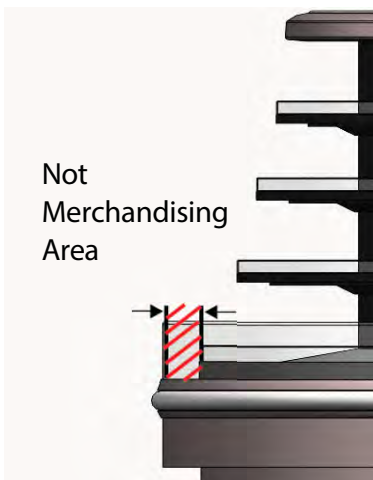

# Warning

Minimum Clearances for TY cases are to be followed as instructed for proper placement inside store locations.

- A minimum clearance of 15' from door opening must be maintained in order for case to remain in optimal performance.
- Side clearances are to be a minimum of 8' when placed next to a solid wall.
- Height clearance measured from floor follows as a minimum of 10' vertically.
- Minimum of 36" clearance if near an open aisle is required for optimal Air Curtain cycling.  
(Assumed 8' clearance from solid wall)

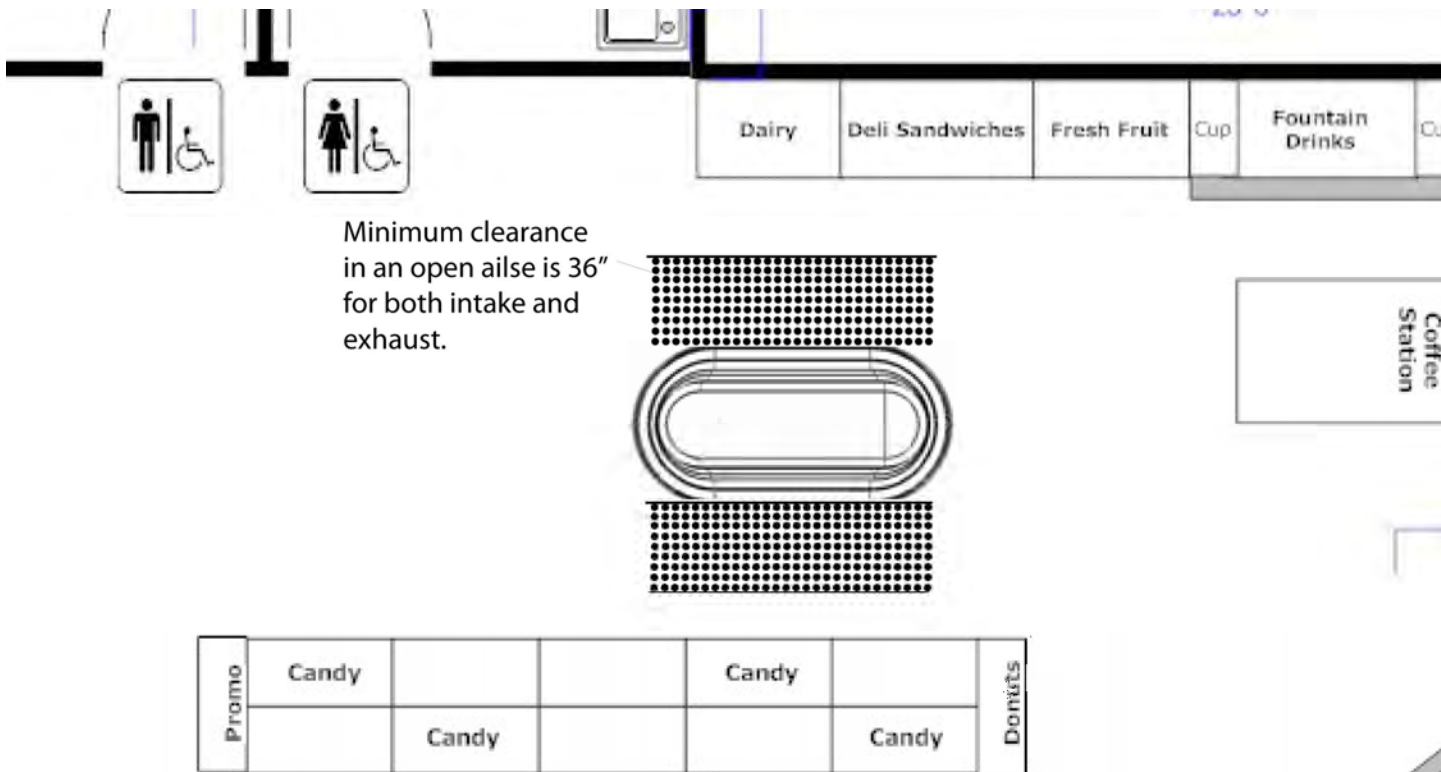

The following figure demonstrates proper clearances for Entyce cases assuming the surrounding walls are solid to ensure optimal performance of the cases Air Curtain.

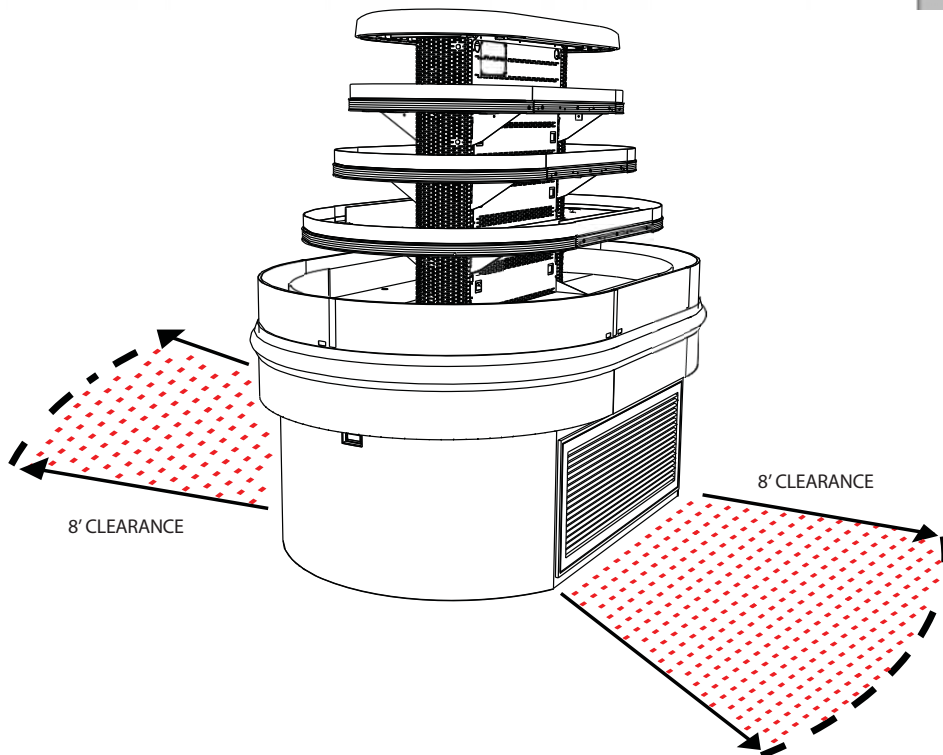

## Warning

Do not place merchandiser near any overhead vents or fans that may affect performance.

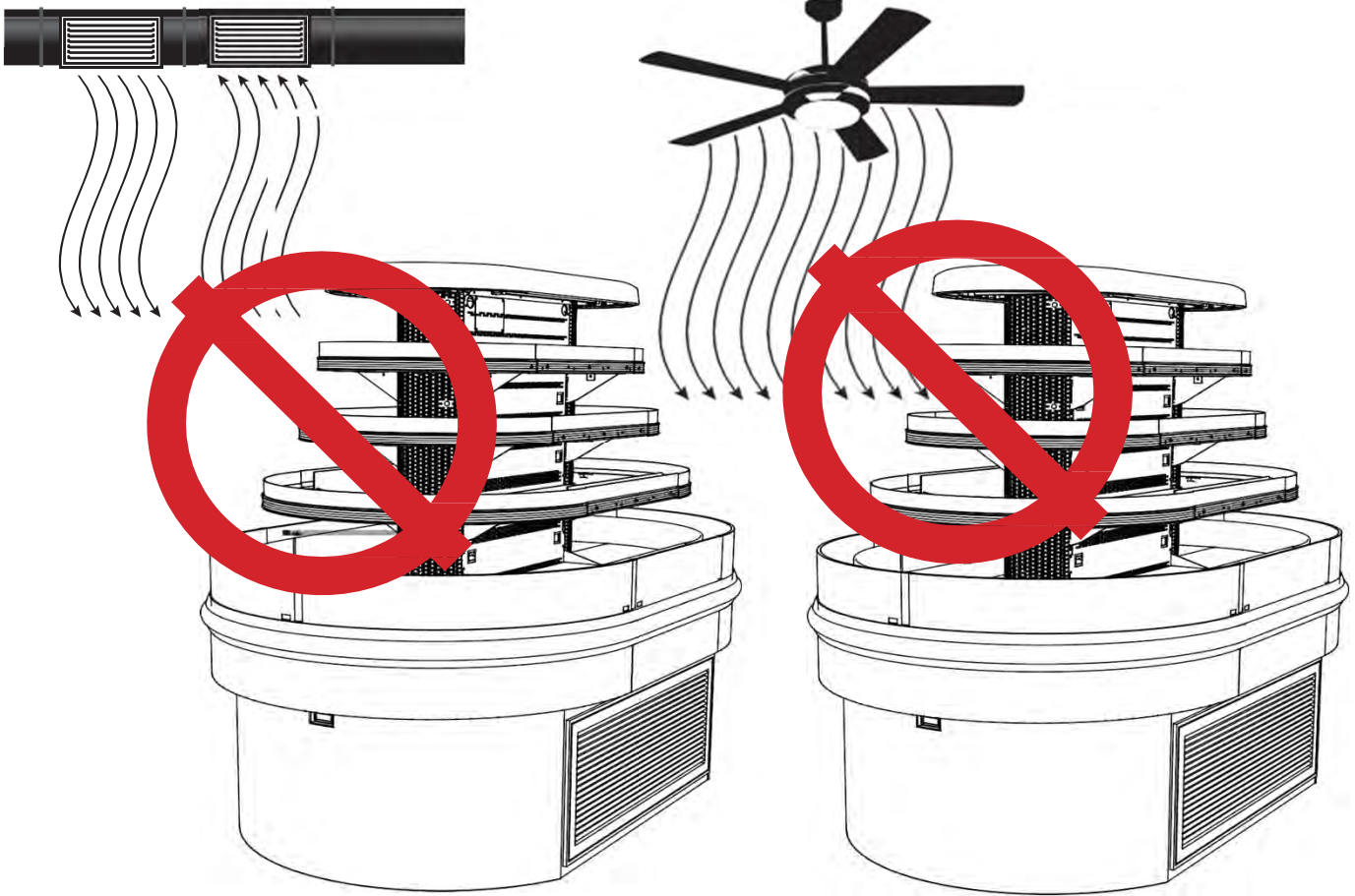

Do not place merchandiser in direct sunlight or sunlight through windows.



## General Information

### Case Description:

This Booklet specifically covers the following models:

- Entyce - TY3
- TY4

**Description:** Entyce A multi deck air curtain Self-Service case designed to display pre-packaged Deli, Bakery, Meat, Seafood, and/or Beverage products.

**Shipping Damage:** All equipment should be thoroughly examined for shipping damage before and during unloading. This equipment has been carefully inspected at our factory and the carrier has assumed responsibility for safe arrival. If damaged, either apparent or concealed, claim must be made to the carrier.

**Apparent Loss or Damage:** If there is an obvious loss or damage, it must be noted on the freight bill or express receipt and signed by the carrier's agent; otherwise, carrier may refuse claim. The carrier will supply necessary claim forms.

**Concealed Loss or Damage:** When loss or damage is not apparent until after all equipment is uncrated, a claim for concealed damage is made. Make request in writing to carrier for inspection within 15 days, and retain all packaging. The carrier will supply inspection report and required claim forms.

**Location/Store Conditions:** The refrigerated merchandisers have been designed for use only in air conditioned stores where temperature and humidity are maintained at 80°F and 55% relative humidity or 75°F and 55% relative humidity. DO NOT allow air conditioning, electric fans, ovens, open doors or windows (etc.) to create air currents around the merchandiser, as this will impair its correct operation.

**Shortages:** Check your shipment for any possible shortages of material. If a shortage should exist and is found to be the responsibility of Hussmann Chino, notify Hussmann Chino. If such a shortage involves the carrier, notify the carrier immediately, and request an inspection. Hussmann Chino will acknowledge shortages within ten days from receipt of equipment.

**Hussmann Chino Product Control:** The serial number and shipping date of all equipment has been recorded in Hussmann's files for warranty and replacement part purposes. All correspondence pertaining to warranty or parts ordering must include the serial number of each piece of equipment involved, in order to provide the customer with the correct parts.

**Keep this booklet with the case at all times for future reference.**

Keep this booklet with the case at all times for future reference.

## HUSSMANN®/CHINO

A publication of HUSSMANN® Chino  
 13770 Ramona Avenue • Chino, California 91710  
 (909) 628-8942 FAX  
 (909) 590-4910  
 (800) 395-9229



This equipment is to be installed to comply with the applicable NEC, Federal, State, and Local Plumbing and Construction Code having jurisdiction.

**TY3-4** 4' wide Merchandiser

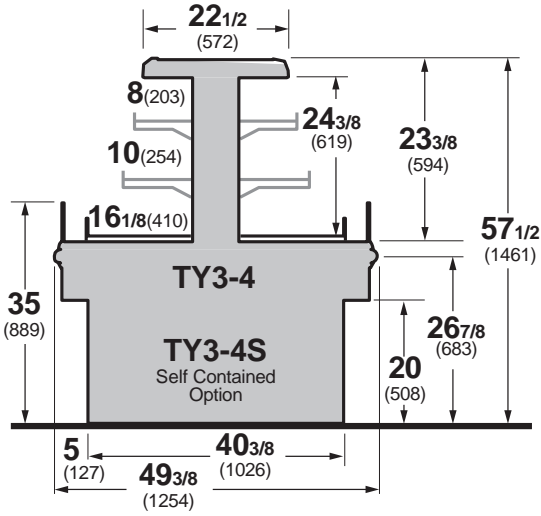

**TY4-4** 4' wide Merchandiser

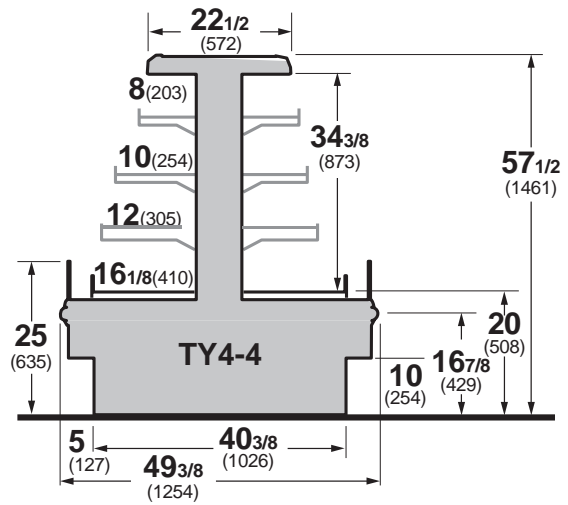

**TY3-5** Entyce 3 level 5' wide island

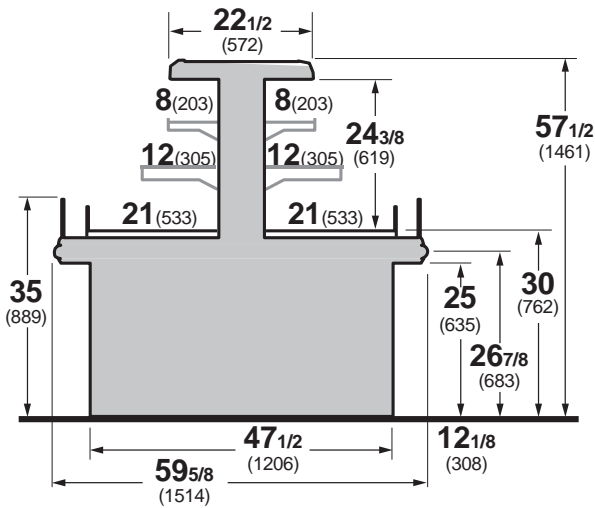

**TY4-6** Entyce 4 level 6' wide island

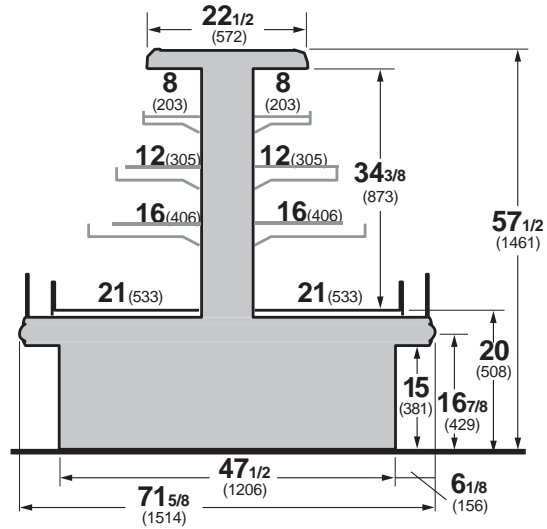

**TY3-6** 6' wide Merchandiser

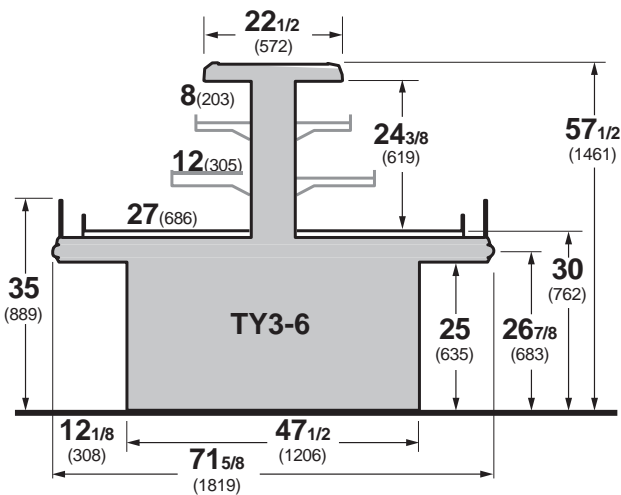

**TY4-6** 6' wide Merchandiser

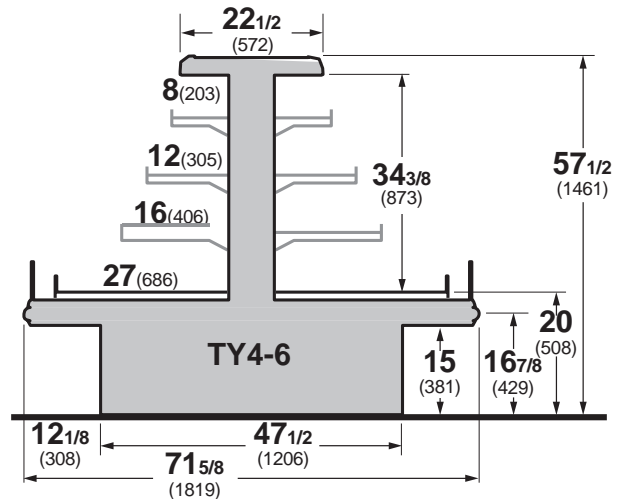

**TY-4** 4' wide Flat End Merchandiser

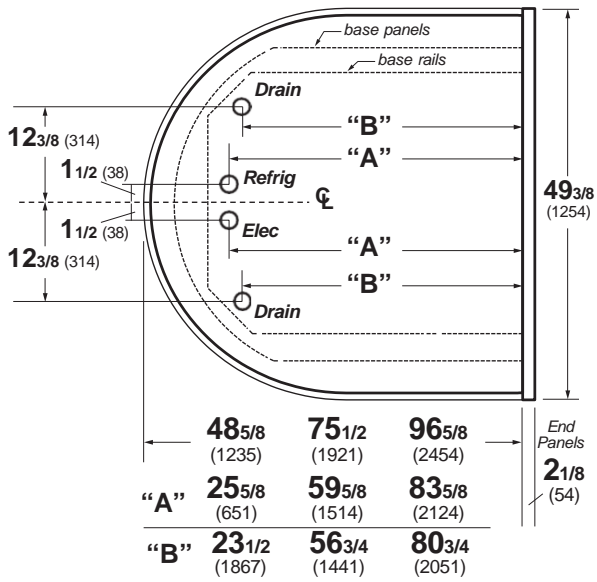

**TY3-6X**(case length) E - Flat End Merchandiser

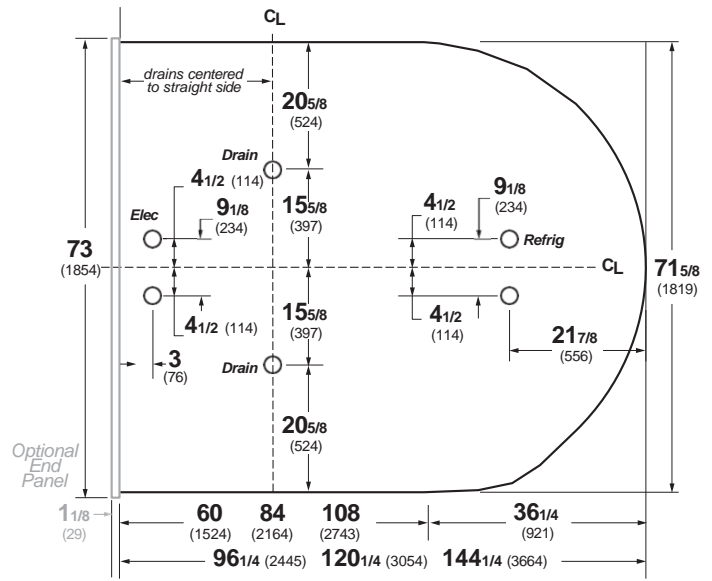

**TY-4** 4' wide Island Merchandiser

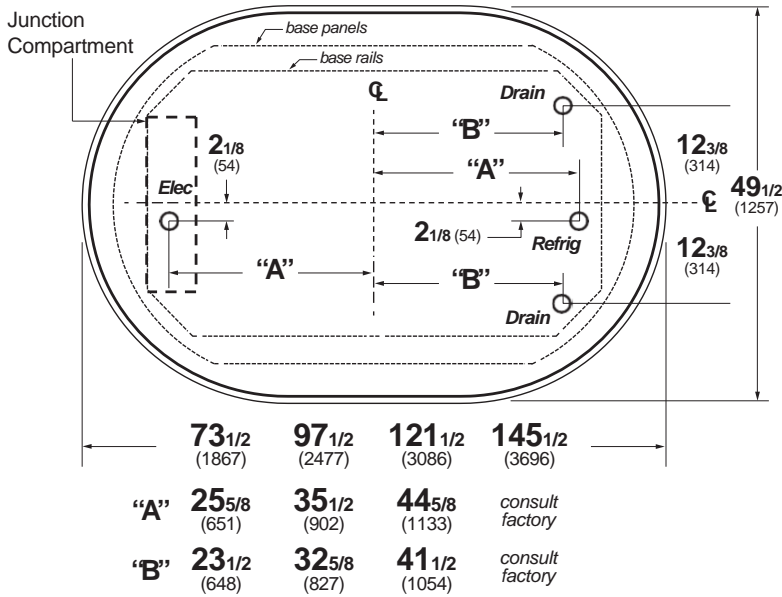

**TY3-6X**(case length) I - Island Merchandiser

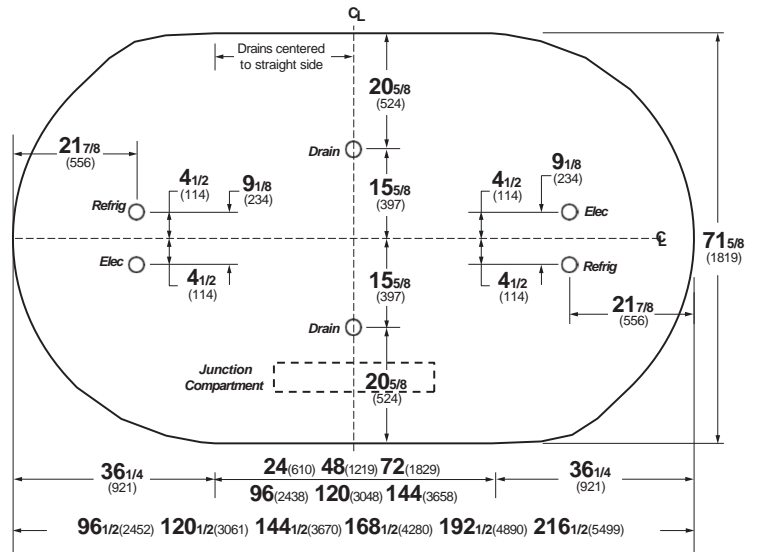

# Installation

## TY Lifting and Transport Instructions

1. The Entyce can be lifted by a forklift at typical lifting points.

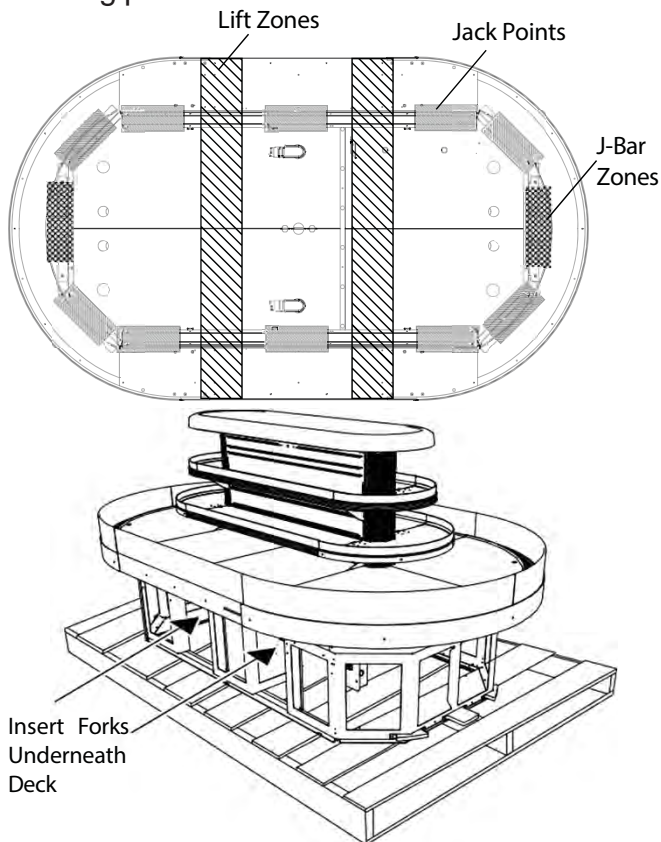

### **WARNING**

Improper placement of forks may damage drainage piping. Use a spotter when placing forks. Make sure that piping will not be damaged. Use J-Bars or Jacks if forks cannot be used safely

2. Ensure lower body panels are removed before lifting with a forklift. Serious damage will occur if the body panels are not removed.
3. Make sure that fork spacing and width will not damage drain or come in contact with piping, or electrical lines
4. Be sure that the forks are long enough to support beyond the center of the case but not damage near components. Check for proper balance before moving. A minimum fork length of 36" is recommended for 68" wide cases

5. The TY merchandiser can be raised at one end underneath the deck with a forklift to allow the placement of rollers or dollies.
6. Evenly support the entire base structure on rollers or dollies before attempting to move. Each Base Leg must have its own dolly to properly support the case.

Lifting Points are typical and dependent upon size of case and refrigeration application, drainage configurations will call for alterations in Lifting Zones.

Below are the following drainage configurations and lifting should be altered to the expected model.

### Full Side Drain

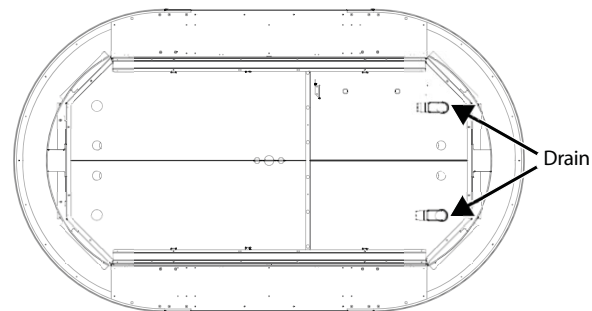

### Center Drain

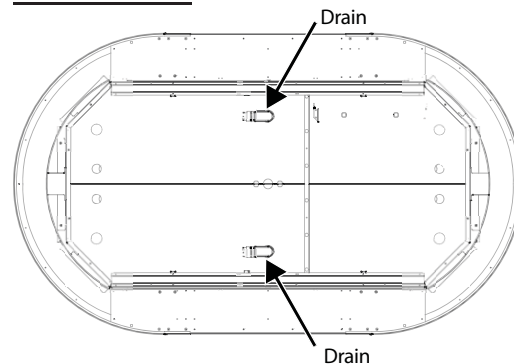

### Center Staggered Drain

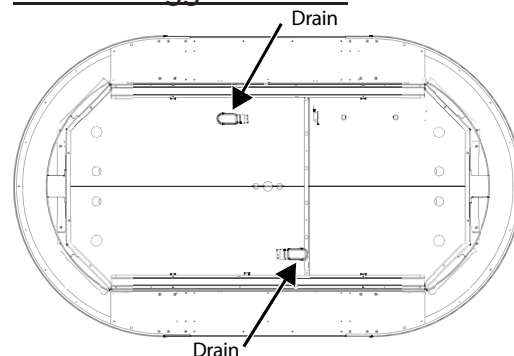

## Installation

### Location

The refrigerated merchandisers have been designed for use only in air conditioned stores where temperature and humidity are maintained at or 75°F and 55% relative humidity or below 80°F and 55% relative humidity. DO NOT allow air conditioning, electric fans, ovens, open doors or windows (etc.) to create air currents around the merchandiser, as this will impair its correct operation.



### Uncrating the Stand

Place the fixture as close to its permanent position as possible. Detach the walls from each other and remove from the skid. Unstrap the case from the skid. The fixture can now be lifted off the crate skid. **Lift only at base of stand!**

### Exterior Loading

These models have not been structurally designed to support excessive external loading. **Do not walk on their tops;** This could cause serious personal injury and damage to the fixture.



**ATTENTION  
INSTALLER**

**It is the contractor's responsibility to install case(s) according to local construction and health codes.**

### Leveling

**A LEVEL CASE IS NECESSARY TO INSURE PROPER OPERATION AND WATER DRAINAGE.** Note: A. To avoid removing concrete flooring, begin lineup leveling from the highest point of the store floor.

## Plumbing

### Waste Outlet and P-TRAP

The waste outlet is located in front and center of the case on both sides which allows for suitable access to each drain allowing drip piping to be run lengthwise under the fixture.

P-traps must be installed at the base of all refrigerated cases. The 1 1/2" P-TRAPS and threaded adapters must be installed to prevent air leakage and insect entrance into the fixture.

### Installing Condensate Drain

Poorly or improperly installed condensate drains can seriously restrict the operation of this refrigerator, and result in costly maintenance and product losses. Please follow the recommendations listed below when installing condensate drains to insure a proper installation:

1. Never use pipe for condensate drains smaller than the nominal diameter of the pipe or P-TRAP supplied with the case.
2. When connecting condensate drains, the P-TRAP must be used as part of the condensate drain to prevent air leakage or insect entrance. Store plumbing system floor drains should be at least 14" off the center of the case to allow use of the P-TRAP pipe section. Never use two water seals in series in any one line. Double P-TRAPS in series will cause a lock and prevent draining.

3. Always provide as much down hill slope ("fall") as possible; 1/8" per foot is the preferred minimum. PVC pipe, when used, must be supported to maintain the 1/8" pitch and to prevent warping.
4. Avoid long runs of condensate drains. Long runs make it impossible to provide the "fall" necessary for good drainage.
5. Provide a suitable air break between the flood rim of the floor drain and outlet of condensate drain. 1" is ideal.
6. Prevent condensate drains from freezing:
  - a. Do not install condensate drains in contact with non-insulated suction lines. Suction lines should be insulated with a nonabsorbent insulation material such as Armstrong's Armaflex.
  - b. Where condensate drains are located in dead air spaces (between refrigerators or between a refrigerator and a wall), provide means to prevent freezing. The water seal should be insulated to prevent condensation.

#### One Sided Drain

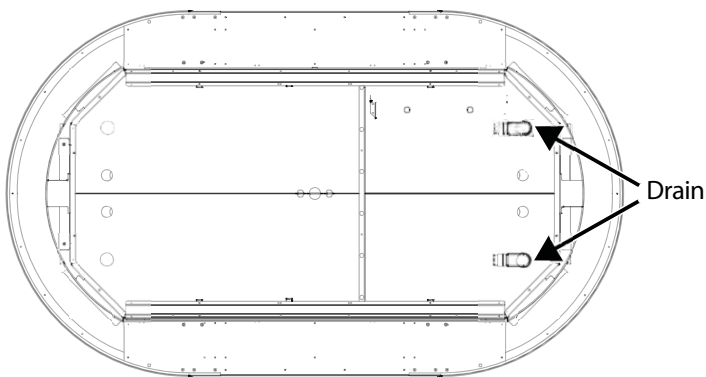

**Note: Cases are typical, length of cases vary**

#### Staggered Center Drain

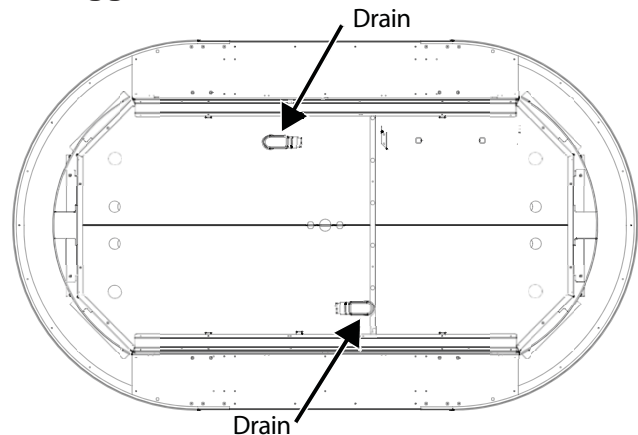

#### Center Drain

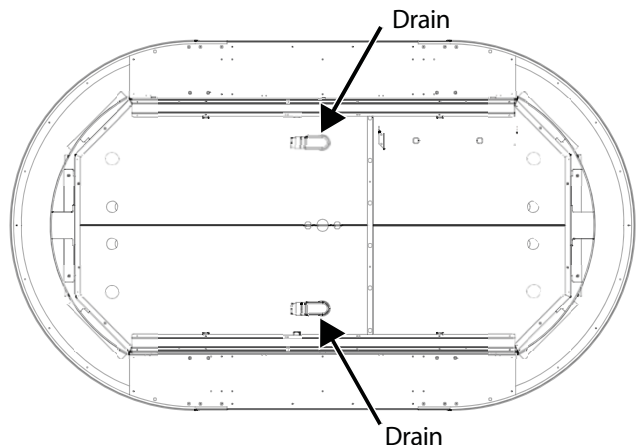

## Refrigeration Piping

The standard refrigerant will be R-404 unless otherwise specified on the customer order. Check the serial plate on the case for information. Refrigeration outlet access and the refrigeration components for the Entyce are situated on the left hand side near the centerline of the case to deliver optimal access which provides for easy installation and maintenance purposes without the probability of damaging any components.

### Refrigeration Lines

<u>Liquid</u>	<u>Suction</u>
3/8" O.D.	5/8" O.D.

Refrigerant lines should be sized as shown on the refrigeration legend furnished by the store.

Oil traps must be installed at the base of all suction line vertical risers on refrigerated cases.

Pressure drop can rob the system of capacity. To keep the pressure drop to a minimum, keep refrigerant line run as short as possible, using the minimum number of elbows. Where elbows are required, use long radius elbows only. All refrigeration components are located underneath the left hand side case deck pans.

**WARNING!**

**Do NOT apply thread sealer to ABS P-Trap.**



# Sump Pump Configuration

## Connecting Sump Lines

For Entyce cases with a Sump Pump Configuration connect liquid line, suction line, electrical, and drain line to top case stub-ups (outlets).

**Note: Isolate Drain line from Suction line either by seperating the lines or insulating the suction line.**

Liquid Line	1/2"	85 fpm
Suction Line	7/8"	1234 fpm

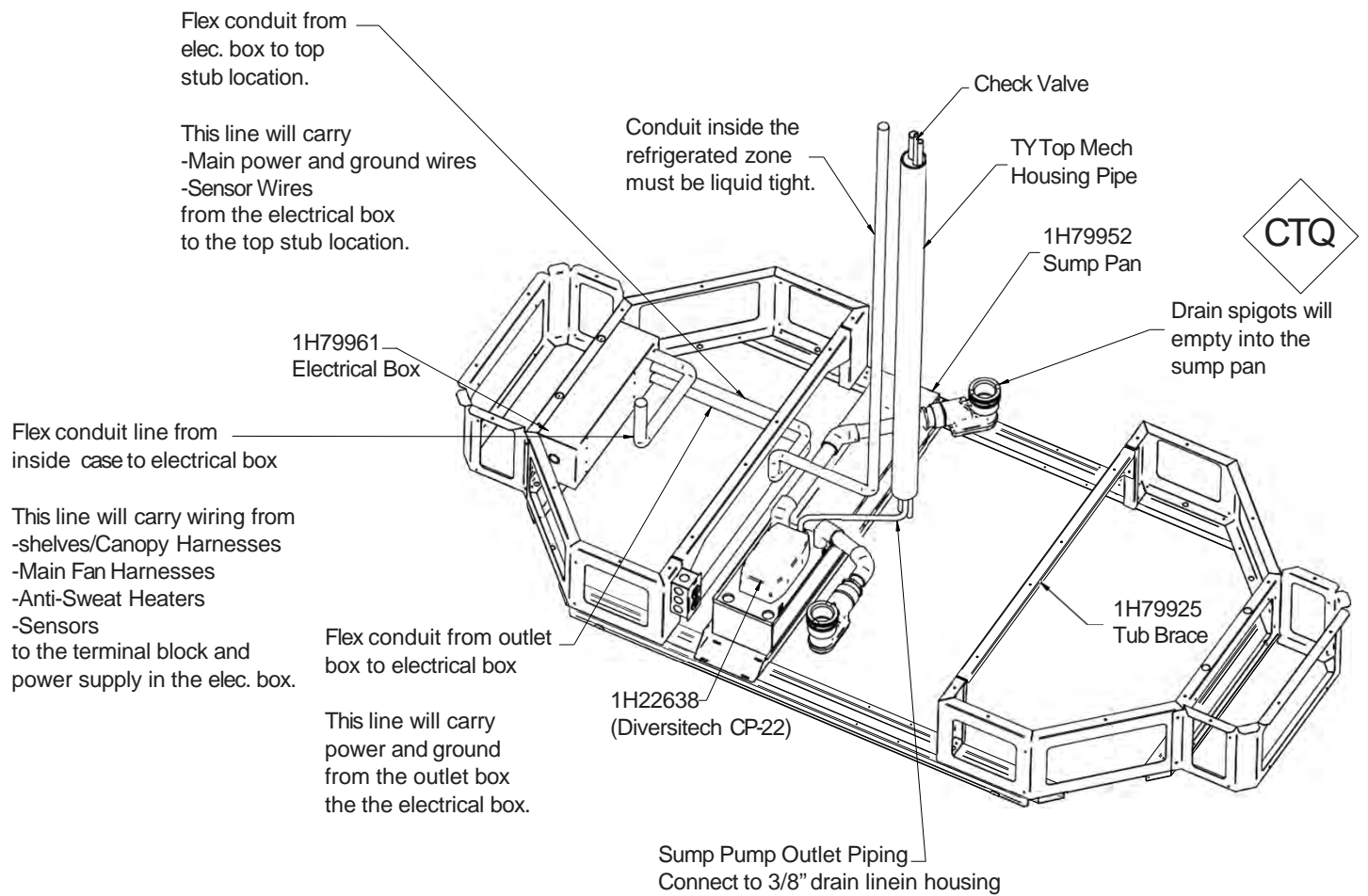
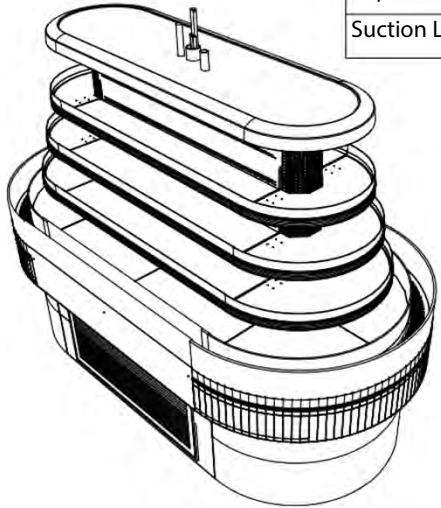

## Sealing Sump Lines

For Entyce cases with a Sump Pump Configuration connect liquid line, suction line, electrical, and drain line to top case stub-ups (outlets).

**Note:** Example below demonstrates the proper method of sealing refrigeration and electrical access points. Ensure tight seal to eliminate any air penetration.

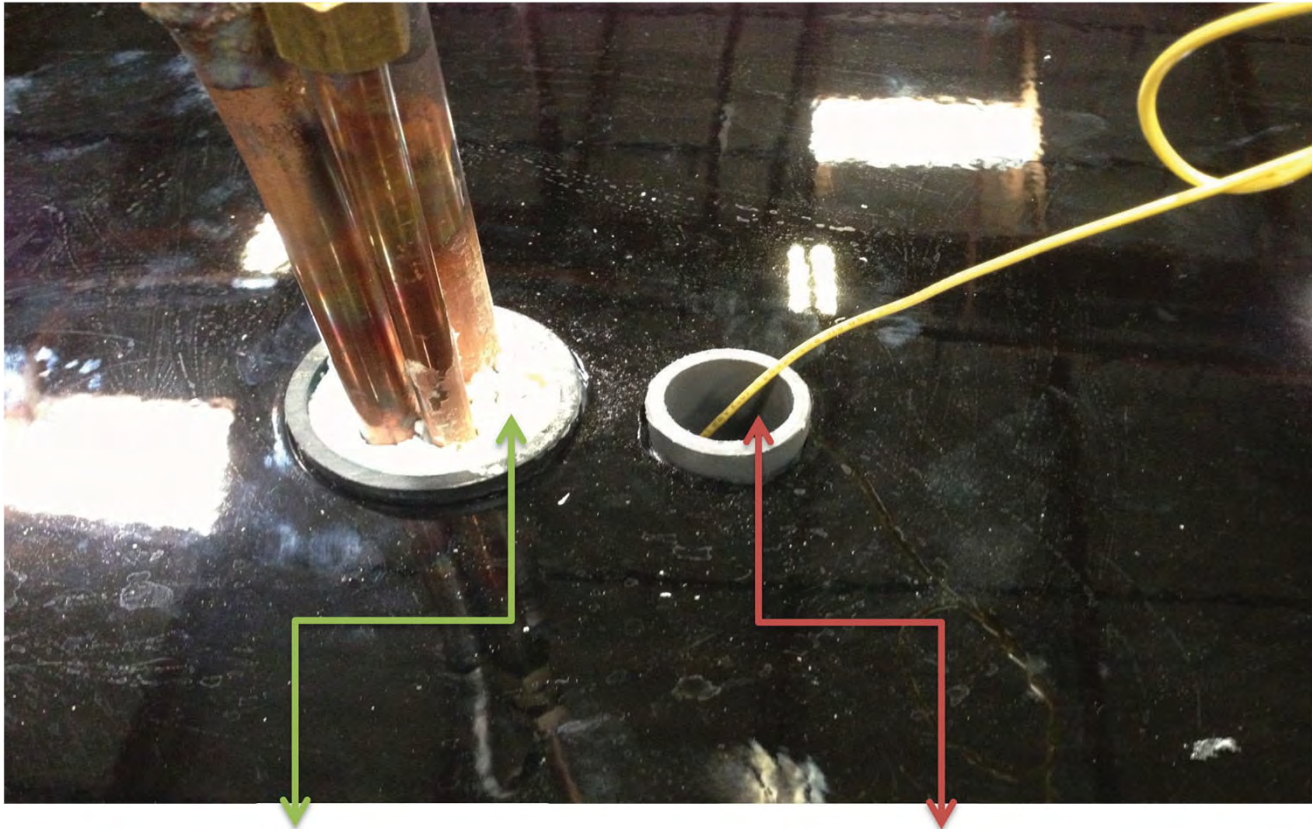

**Sealed refrigeration lines inside of pipe.**

**This is an EXAMPLE of how to properly seal electrical lines (using silicone) once electrical lines are pulled using provided wire-chase.**

**Installers: After running electrical you MUST seal top (shown here) and bottom of this pipe to eliminate any air penetration!**

**Failure to do so will cause condensation inside of pipe and water will drip on floor!**

**Silicone is an acceptable material to seal pipe.**



**SELF-SERVICE DELI**  
**HUSSMANN - TY1-6 I-ISLAND (CHINO)**

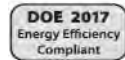

Hussmann refrigerated merchandisers configured for sale for use in the United States meet or surpass the requirements of the DOE 2017 energy efficiency standards.

REVISION DATE

15 10/6/17

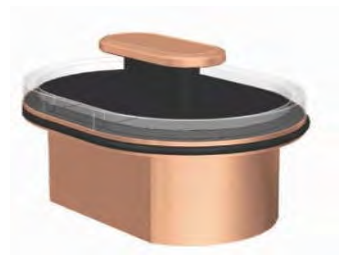

**TY1-6** Single Level 6' wide Island

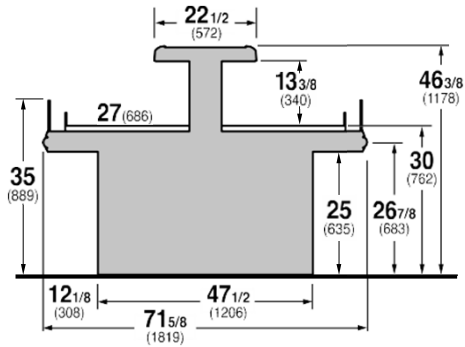

**TY1-6X** (case length) I - Island Merchandiser

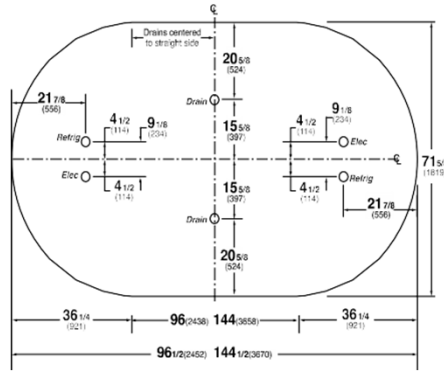

**REFRIGERATION DATA:**

CASE LENGTHS	CASE USAGE	CAPACITY *** (BTU/HR) TOTAL		TEMPERATURE (°F)			VELOCITY (FT/MIN)
		RATING CONDITION		EVAPORATOR		DISCHARGE AIR ** (°F)	
		NSF 7	AHRI 1200	NSF 7	AHRI 1200	NSF 7	NSF 7
8'-1	DELI	9600	9600	24	24	30-32	150-200
12'-1	DELI	14400	14400	24	24	30-32	150-200

CASE LENGTHS	EST. REFG. CHR.G. 404A (LBS)	GLYCOL (20°F INLET, 6° RISE)	
		GPM	PSI
8'-1	1.1	3.4	4.6
12'-1	1.8	5.0	4.4

\*\*FRONT DISCHARGE AIR MEASURED INSIDE AIR CURTAIN HONEYCOMB

\*\*\*REFRIGERATION NOTES:

- 1) BTUS DO NOT INCLUDE LIGHTS.
- 2) ADD 10 BTU'S PER FOOT OF LED SHELF LIGHTS PER LIGHT MATRIX BELOW.
- 3) AHRI 1200 RATING POINT FOR ENERGY CONSUMPTION COMPARISON ONLY.
- 4) USE DEW POINT FOR HIGH GLIDE REFRIGERANTS. CARE SHOULD BE TAKEN TO USE THE DEW POINT IN P/T TABLES FOR MEASURING AND ADJUSTING SUPERHEAT. ADJUST EVAPORATOR PRESSURE AS NEEDED TO MAINTAIN THE DISCHARGE AIR TEMPERATURE SHOWN.
- 5) RATING CONDITION IS NSF TYPE I, 75°F/55% RH.

**REFRIGERATION DATA CONTINUED:**

ELEC. THERMOSTAT / AIR SENSOR SETTINGS			DEFROST TYPE	TIME (MIN)	DEFROST FREQUENCY (#/DAY)	TERM. TEMP (°F) COIL ONLY	DRIP TIME	DEFROST WATER (LBS/DAY/FT)
USAGE	CUT IN (°F)	CUT OUT (°F)						
DELI	32	29	OFF TIME	16	12	48	TBD	9.5

END PANEL WIDTH KEY		
# OF END PNLS	END PNL WIDTH (IN.)	TOTAL ADDED LENGTH (IN.)
1	1.125	1.125

**ELECTRICAL DATA:**

**STANDARD FANS, HEATERS, LED LIGHTS (115 VOLT)**

CASE LENGTH	EVAPORATOR FANS					CANOPY LIGHTS LED		OPTIONAL LED SHELF LIGHTS		MAX. LED LOAD (W/ ALL OPTIONS)		ANTI-SWEAT HEATERS (ON FAN CIRCUIT)		CONVENIENCE OUTLETS (OPTIONAL)			LIGHT MATRIX
	# OF EVAP FANS	BLADE DIA. (IN.)	BLADE PITCH (°)	AMPS	WATTS	AMPS	WATTS	AMPS	WATTS	AMPS	WATTS	AMPS	WATTS	# OUTLETS	VOLTS	AMPS	FT OF LEDS
8'-1	6	8	10	1.8	48	0.12	14	N/A	N/A	0.12	14	0.43	50	1	115	15	6
12'-1	10	8	10	3	80	0.30	35	N/A	N/A	0.30	35	0.78	90	1	115	15	14

**OPTIONAL HIGH OUTPUT LED LIGHTS (115 VOLT)**

CASE LENGTH	CANOPY LIGHTS H.O. LED		OPTIONAL SHELF		MAX. H.O. LED LOAD	
	AMPS	WATTS	AMPS	WATTS	AMPS	WATTS
8'-1	N/A	N/A	N/A	N/A	N/A	N/A
12'-1	N/A	N/A	N/A	N/A	N/A	N/A



**SELF-SERVICE DELI CHEESE**

HUSSMANN - TY3-5 I-ISLAND (CHINO)



Hussmann refrigerated merchandisers configured for sale for use in the United States meet or surpass the requirements of the DOE 2017 energy efficiency standards.

REVISION DATE 03/21/17

**TY3-5** Entyce 3 level 5' wide island

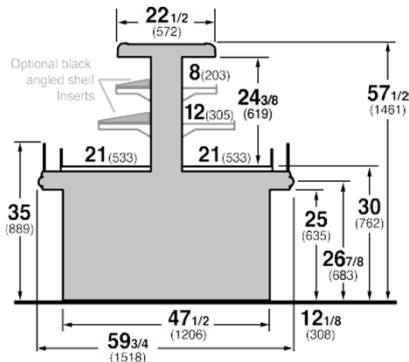

**TY3-5, TY4-5** 5' wide Island Merchandiser

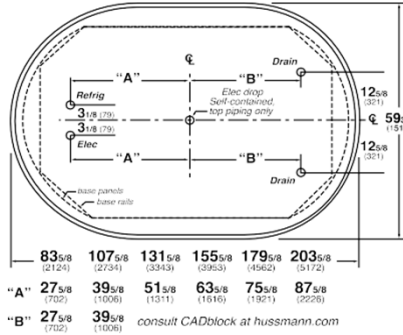

**REFRIGERATION DATA:**

CASE LENGTHS	CASE USAGE	CAPACITY *** (BTU/HR)		TEMPERATURE (°F)			VELOCITY (FT/MIN)
		RATING CONDITION		EVAPORATOR		DISCHARGE AIR ** (°F)	
		NSF 7	AHRI 1200	NSF 7	AHRI 1200	NSF 7	
71	DELI / CHEESE	10770	10770	26	26	30-33	175-250
91	DELI / CHEESE	13790	13790	26	26	30-33	175-250
111	DELI / CHEESE	16810	16810	26	26	30-33	175-250
131	DELI / CHEESE	19830	19830	26	26	30-33	175-250
151	DELI / CHEESE	22850	22850	26	26	30-33	175-250
171	DELI / CHEESE	25870	25870	26	26	30-33	175-250

CASE LENGTHS	EST. REFG. CHR.G. (LBS)	20°F GLYCOL 6° RISE	
		GPM	PSI
71	1.1	3.8	5.2
91	1.3	4.8	3.8
111	1.8	5.8	5.1
131	2.2	6.7	6.7
151	2.7	7.6	4.7
171	3.1	8.5	5.4

\*\*FRONT DISCHARGE AIR MEASURED INSIDE AIR CURTAIN HONEYCOMB

\*\*\*REFRIGERATION NOTES:

- 1) BTUS ARE SHOWN WITHOUT LIGHTS
- 2) ADD 10 BTU/FT OF LED LIGHTS PER LIGHT MATRIX BELOW
- 3) AHRI 1200 RATING POINT FOR ENERGY CONSUMPTION COMPARISON ONLY
- 4) USE DEW POINT FOR HIGH GLIDE REFRIGERANTS. CARE SHOULD BE TAKEN TO USE THE DEW POINT IN P/T TABLES FOR MEASURING AND ADJUSTING SUPERHEAT. ADJUST EVAPORATOR PRESSURE AS NEEDED TO MAINTAIN THE DISCHARGE AIR TEMPERATURE SHOWN.
- 5) RATING CONDITION IS NSF TYPE I, 75°F/55% RH

**REFRIGERATION DATA CONTINUED:**

SENSOR SETTINGS		DEFROST TYPE	TIME (MIN)	DEFROST FREQUENCY (#/DAY)	TERM. TEMP (°F) COIL ONLY	DRIP TIME	DEFROST WATER (LBS/DAY/FT)
USAG	CUT IN (°F)						
DELI / CHEESE	33	OFF TIME	16	12	48	N/A	11

END PANEL WIDTH KEY		
# OF END PNLS	END PNL WIDTH (IN.)	TOTAL ADDED LENGTH (IN.)
1	1.125	1.125
2	1.125	2.25

**ELECTRICAL DATA:**

**STANDARD FANS, HEATERS, LED LIGHTS (115 VOLT)**

CASE LENGTH	EVAPORATOR FANS				CANOPY LIGHTS LED		OPTIONAL LED SHELF LIGHTS		MAX. LED LOAD (W/ ALL OPTIONS)		ANTI-SWEAT HEATERS (ON FAN CIRCUIT)		CONVENIENCE OUTLETS (OPTIONAL)			LIGHT MATRIX FEET	
	# OF EVAP FANS	BLADE DIA. (IN.)	BLADE PITCH (°)	AMPS	WATTS	AMPS	WATTS	AMPS	WATTS	AMPS	WATTS	AMPS	WATTS	# OUTLETS	VOLTS		AMPS
71	6	8	15	1.8	48	0.12	14.27	0.29	32.99	0.41	47	0.43	50	1	115	15	22
91	8	8	15	2.4	64	0.22	25.04	0.47	54.52	0.69	80	0.61	70	1	115	15	34
111	10	8	15	3.0	80	0.30	34.87	0.65	74.18	0.95	109	0.78	90	1	115	15	46
131	12	8	10	3.6	96	0.40	45.63	0.83	95.71	1.23	141	0.96	110	1	115	15	58
151	14	8	10	4.2	112	0.49	56.39	1.02	117.23	1.51	174	1.04	120	1	115	15	70
171	16	8	10	4.8	128	0.57	65.29	1.17	135.02	1.74	200	1.22	140	1	115	15	82

**OPTIONAL HIGH OUTPUT LED LIGHTS (115 VOLT)**

CASE LENGTH	CANOPY LIGHTS H.O. LED		OPTIONAL SHELF		MAX. H.O. LED LOAD	
	AMPS	WATTS	AMPS	WATTS	AMPS	WATTS
71	N/A	N/A	N/A	N/A	N/A	N/A
91	N/A	N/A	N/A	N/A	N/A	N/A
111	N/A	N/A	N/A	N/A	N/A	N/A
131	N/A	N/A	N/A	N/A	N/A	N/A
151	N/A	N/A	N/A	N/A	N/A	N/A
171	N/A	N/A	N/A	N/A	N/A	N/A



**SELF-SERVICE DELI CHEESE**  
**HUSSMANN - TY4-5 ISLAND (CHINO)**

REVISION DATE 6/20/2018



Hussmann refrigerated merchandisers configured for sale for use in the United States meet or surpass the requirements of the DOE 2017 energy efficiency standards.

**TY-5 5' wide Island Merchandiser**

TY4-5 Entyce 4 level 5' wide island

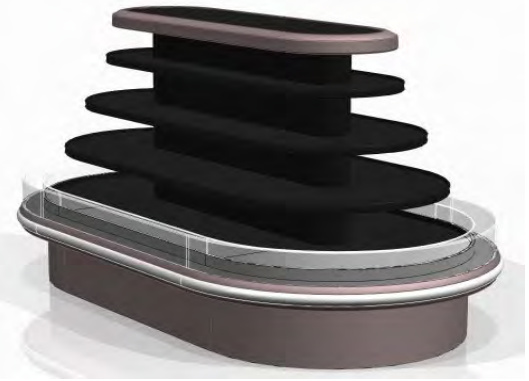
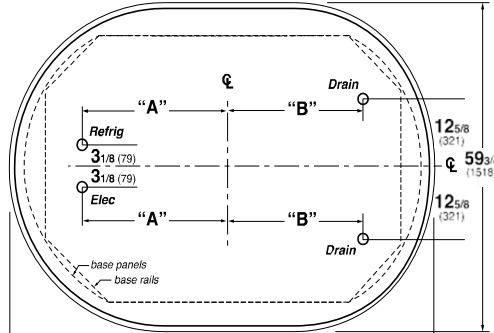
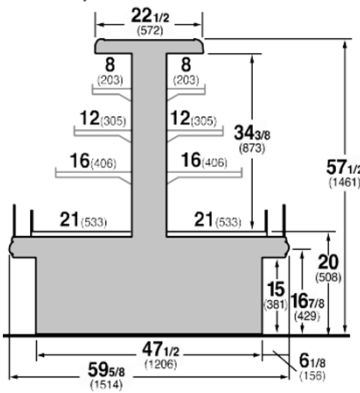

	83 <sup>5/8</sup> (2124)	107 <sup>5/8</sup> (2734)	131 <sup>5/8</sup> (3343)	155 <sup>5/8</sup> (3953)	179 <sup>5/8</sup> (4562)	203 <sup>5/8</sup> (5172)
"A"	27 <sup>5/8</sup> (702)	39 <sup>5/8</sup> (1006)	51 <sup>5/8</sup> (1311)	63 <sup>5/8</sup> (1616)	75 <sup>5/8</sup> (1921)	87 <sup>5/8</sup> (2226)
"B"	27 <sup>5/8</sup> (702)	39 <sup>5/8</sup> (1006)	consult CADblock at hussmann.com			

**REFRIGERATION DATA:**

CASE LENGTHS	CASE USAGE	CAPACITY *** (BTU/HR)		TEMPERATURE (°F)			VELOCITY (FT/MIN)
		RATING CONDITION		EVAPORATOR		DISCHARGE AIR ** (°F)	
		NSF 7	AHRI 1200	NSF 7	AHRI 1200	NSF 7	
7I	DELI /	13660	13660	22	22	28-30	100-150
9I	DELI /	17500	17500	22	22	28-30	100-150
11I	DELI /	21340	21340	22	22	28-30	100-150
13I	DELI /	25180	25180	22	22	28-30	100-150
15I	DELI /	29000	29000	22	22	28-30	100-150
17I	DELI /	32850	32850	22	22	28-30	100-150

CASE LENGTHS	EST. REFG. CHR.G. 404A (LBS)	GLYCOL (20°F INLET, 6° RISE)	
		GPM	PSI
7I	1.1	4.8	6.8
9I	1.3	6.2	4.9
11I	1.8	7.4	6.7
13I	2.2	8.7	8.7
15I	2.7	9.8	6.1
17I	3.1	11.0	7.0

\*\*FRONT DISCHARGE AIR MEASURED INSIDE AIR CURTAIN HONEYCOMB

\*\*\*REFRIGERATION NOTES:

- 1) BTU'S SHOWN ARE WITHOUT LIGHTS.
- 2) ADD 10 BTU'S PER FOOT OF LED LIGHTS PER LIGHT MATRIX BELOW.
- 3) AHRI 1200 RATING POINT FOR ENERGY CONSUMPTION COMPARISON ONLY.
- 4) USE DEW POINT FOR HIGH GLIDE REFRIGERANTS. CARE SHOULD BE TAKEN TO USE THE DEW POINT IN P/T TABLES FOR MEASURING AND ADJUSTING SUPERHEAT. ADJUST EVAPORATOR PRESSURE AS NEEDED TO MAINTAIN THE DISCHARGE AIR TEMPERATURE SHOWN.
- 5) RATING CONDITION IS NSF TYPE I, 75°F/55% RH.

**REFRIGERATION DATA CONTINUED:**

ELEC. THERMOSTAT / AIR SENSOR SETTINGS		DEFROST TYPE	TIME (MIN)	DEFROST FREQUENCY (#/DAY)	TERM. TEMP (°F) COIL ONLY	DRIP TIME	DEFROST WATER (LBS/DAY/FT)
USAGE	CUT IN (°F)						
DELI / CHEESE	31	28	OFF TIME	16	12	N/A	12

END PANEL WIDTH KEY		
# OF END PNLS	END PNL WIDTH (IN.)	TOTAL ADDED LENGTH (IN.)
1	1.125	1.125
2	1.125	2.25

**ELECTRICAL DATA:**

**STANDARD FANS, HEATERS, LED LIGHTS (115 VOLT)**

CASE LENGTH	EVAPORATOR FANS				CANOPY LIGHTS LED		OPTIONAL LED SHELF LIGHTS		MAX. LED LOAD (W/ ALL OPTIONS)		ANTI-SWEAT HEATERS (ON FAN CIRCUIT)		CONVENIENCE OUTLETS (OPTIONAL)			LIGHT MATRIX	
	# OF EVAP FANS	BLADE DIA. (IN.)	BLADE PITCH (°)	AMPS	WATTS	AMPS	WATTS	AMPS	WATTS	AMPS	WATTS	AMPS	WATTS	# OUTLETS	VOLTS		AMPS
7I	6	8	20	1.8	48	0.12	14	0.57	66	0.70	80	0.43	50	1	115	15	34
9I	8	8	20	2.4	64	0.22	25	0.85	98	1.07	123	0.61	70	1	115	15	50
11I	10	8	20	3	80	0.30	35	1.11	128	1.41	162	0.78	90	1	115	15	66
13I	12	8	15	3.6	96	0.40	46	1.39	160	1.79	205	0.96	110	1	115	15	82
15I	14	8	15	4.2	112	0.49	56	1.67	192	2.16	249	1.04	120	1	115	15	98
17I	16	8	15	4.8	128	0.57	65	1.90	219	2.47	284	1.22	140	1	115	15	114

**OPTIONAL HIGH OUTPUT LED LIGHTS (115 VOLT)**

CASE LENGTH	CANOPY LIGHTS H.O. LED		OPTIONAL SHELF		MAX. H.O. LED LOAD	
	AMPS	WATTS	AMPS	WATTS	AMPS	WATTS
7I	N/A	N/A	N/A	N/A	N/A	N/A
9I	N/A	N/A	N/A	N/A	N/A	N/A
11I	N/A	N/A	N/A	N/A	N/A	N/A
13I	N/A	N/A	N/A	N/A	N/A	N/A
15I	N/A	N/A	N/A	N/A	N/A	N/A
17I	N/A	N/A	N/A	N/A	N/A	N/A

## Electrical

STANDARD CASE WIRE COLOR CODE CODIGO DE COLORES DE LOS ALAMBRES PARA LAS VITRINAS ESTANDAR CODE COULER POUR FILS DE BOITIER NORMALISE		
COLOR DESCRIPTION	DESCRIPCION	DESCRIPTION
■ GROUND	TIERRA MASA	MASSE
■ ANTI-SWEAT	ANTICONDENSACION	ANTI-SUINTEMENT
■ LIGHTS	LUCES	ECLAIRAGE
■ RECEPTACLES	ENCHUFES	PRISE DE COURANT
■ T-STAT/SOLENOID 230VAC	TERMOSTATO/SOLENOIDE (230VAC)	SOUPAPE A SOLENOID (230 VAC)
■ T-STAT/SOLENOID 115VAC	TERMOSTATO/SOLENOIDE (115VAC)	SOUPAPE A SOLENOID (115 VAC)
■ T-STAT/SOLENOID 24VAC	TERMOSTATO/SOLENOIDE (24VAC)	SOUPAPE A SOLENOID (24 VAC)
■ FAN MOTORS	VENTILADORES	VENTILATEUR
■ BLUE CONDENSING UNIT	UNIDAD DE CONDENSACION	UNITE DE CONDENSATION

**USE COPPER CONDUCTORS ONLY**  
**UTILISEZ LES CONDUCTEURS DE CUIVRE SEULEMENT**  
**UTILICE LOS CONDUCTORES DE COBRE SOLAMENTE**  
 430-01-0338 R101003

### **CASE MUST BE GROUNDED**

**NOTE:** Refer to label affixed to case to determine the actual configuration as checked in the "TYPE INSTALLED" boxes.

Standard lighting for all refrigerated models will be full length LED Lights located within the case at the top.

## Field Wiring and Serial Plate Amperage

Field Wiring must be sized for component amperes printed on the serial plate. Actual ampere draw may be less than specified. Field wiring from the refrigeration control panel to the merchandisers is required for refrigeration thermostats. Case amperes are listed on the wiring diagram, but always check the serial plate.



**DANGER**

**BEFORE SERVICING  
 ALWAYS DISCONNECT ELECTRICAL  
 POWER AT THE MAIN DISCONNECT  
 WHEN SERVICING OR REPLACING ANY  
 ELECTRICAL COMPONENT.  
 This includes (but not limited to) Fans, Heaters  
 Thermostats, and Lights.**

**Wiring Diagrams Index**

<b>TY1</b>	<b>5X7I-R</b>	<b>7'</b>	<b>3053753</b>
	<b>6X8I-R</b>	<b>8'</b>	<b>3008179</b>
	<b>6X12I-R</b>	<b>12'</b>	<b>3014692</b>

<b>TY3</b>	<b>4X6I-R</b>	<b>6'</b>	<b>1H85155</b>
	<b>4X8I-R</b>	<b>8'</b>	<b>1H91354</b>
	<b>4X10I-R</b>	<b>10'</b>	<b>3047530</b>
	<b>4X12I-R</b>	<b>12'</b>	<b>3008178</b>
	<b>5X7I-R</b>	<b>7'</b>	<b>3008177</b>
	<b>5X9I-R</b>	<b>9'</b>	<b>2H00213</b>
	<b>5X11I-R</b>	<b>11'</b>	<b>1H86614</b>
	<b>5X13I-R</b>	<b>13'</b>	<b>3008175</b>
	<b>6X8C-R</b>	<b>8'</b>	<b>3013478</b>
	<b>6X8I-R</b>	<b>8'</b>	<b>1H86612</b>
	<b>ECSQ-6X8I-R</b>	<b>8'</b>	<b>3017118</b>
	<b>6X10I-R</b>	<b>10'</b>	<b>1H78139</b>
	<b>6X12I-R</b>	<b>12'</b>	<b>3047528</b>
	<b>ECSQ-6X12I-R</b>	<b>12'</b>	<b>3048459</b>
	<b>6X14I-R</b>	<b>14'</b>	<b>1H77864</b>
	<b>ECRC-6X14I-R</b>	<b>14'</b>	<b>3055337</b>
	<b>6X16I-R</b>	<b>16'</b>	<b>1H93522</b>
	<b>ECRC-6X16I-R 10" &amp; 14" SHELVES</b>	<b>16'</b>	<b>3059427</b>
	<b>6X18I-R</b>	<b>18'</b>	<b>3013482</b>

## Wiring Diagrams Index (cont'd)

TY4	4X6I-R	6'	3047021
	4X10I-R	10'	3013474
	4X12I-R	12'	1H89619
	5X7I-R	7'	2H00212
	ECRC-5X7I-R	7'	3144548
	TY4EC-5X7I-R	7'	3078669
	5X9I-R	9'	2H14403
	5X11I-R	11'	1H92381
	5X12C-R	12'	3142085
	TY4EC-5X13I-R W/OPTIONAL SUMP PUMP	13'	2H22482
	TY4EC-5X13I-R 8",10",12" SHELVES	13'	3030997
	TY4EC-5X17I-R, 10",12",14" SHELVES	17'	3058176
	5X13I-R	13'	2H01103
	5X15I-R	15'	1H92380
	5X17I-R	17'	3008164
	6X8C-R	8'	1H89148
	TY4ECRC-6X8I-R ULTRA LED TOP, 12",14",16"	8'	3107535
	TY4ECRC-6X8I-R ULTRA LED TOP, 10",12",16"	8'	3123818
	TY4ECRC-6X8C-R HO CANOPY LIGHTS	8'	3064025
	6X8I-R	8'	1H85454
	6X10I-R	10'	1H93524
	6X12I-R	12'	1H91310
	TY4ECRC-6X12I-R 12" & 16" SHELVES	12'	3047242
	TY4ECRC-6X12I-R 10",12" & 14" SHELVES	12'	3080512
	TY4ECRC-6X12I-R 12",14" & 16" SHELVES	12'	3092240
	6X14I-R	14'	1H84139
	TY4ECRC-6X14I-R	14'	3047157
	6X16I-R	16'	1H85195
	TY4ECRC-6X16I-R	16'	3043948
	TY4ECRC-6X18I-R W/LEDGE LIGHTS ALSO	18'	3160164
	6X18I-R	18'	1H77863

CIRCUIT #1

LOADING			
120V			
L1			
L2			

LIGHT CIRCUIT  
26A 27.8W @ 120V

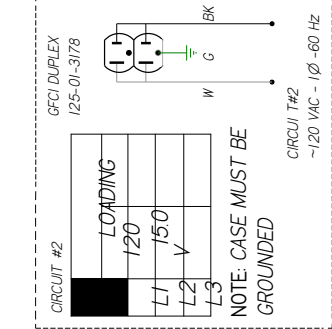
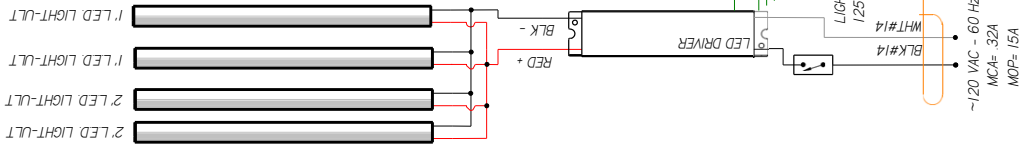

ANTI-SWEAT HEATER  
50W 0.42A @ 120VAC  
0497590

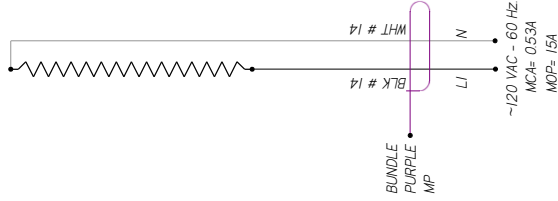

EVAPORATOR FAN  
12W 0.30A @ 120VAC (Ø)  
0477655

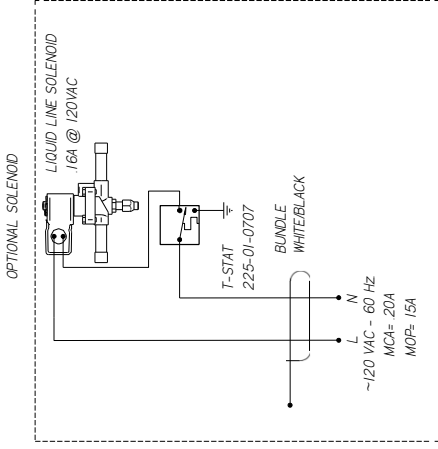
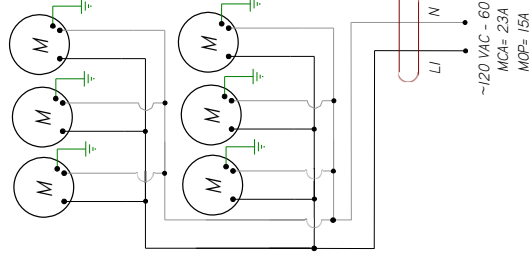

REV	EN	DATE	REVISION DESCRIPTION	REV BY	CHKD BY	APPR BY
A	EDY-CAP-000822	2018/01/27	RELEASED TO PRODUCTION	CB	CB	CB
B	EDY-COD-005276	2022/02/17	NEW LIGHTS	CB	CB	CB

**HUSSMANN**  
DIAGRAM=1YI-5X71-R

MATERIAL - NA  
DATE DRAWN - 1-17-18  
DRAWN BY - CRAIG ROOREY  
REVIEWED BY - CRAIG ROOREY  
APPROVED BY - CRAIG ROOREY  
UNLESS OTHERWISE SPECIFIED DIMENSIONS ARE IN INCHES  
TOLERANCES ARE:  
THIRD ANGLE PROJECTION  
DECIMALS .XX ±0.3 .XXX ±0.10 ANGLES ± 2°

REF - SHEET 1 OF 1

3053753 | B

NOTES:  
CASE MUST BE GROUNDED  
WHEN PASSING WIRES THROUGH METAL HOLES A GROMMET MUST BE USED

CIRCUIT #1

LOADING	
L1	120V
L2	150V
L3	

LIGHT CIRCUIT  
26A 278W @ 120V

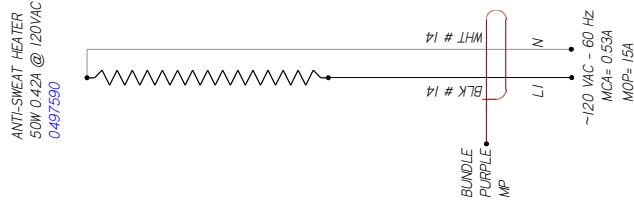
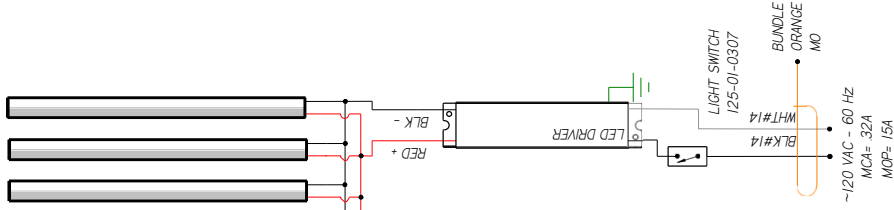
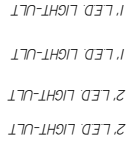

EVAPORATOR FAN  
12W 0.30A @ 120VAC (6)  
0477655

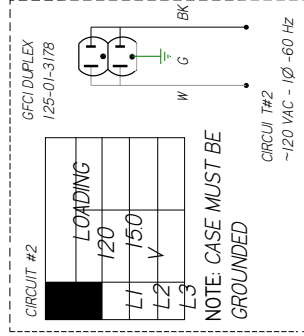
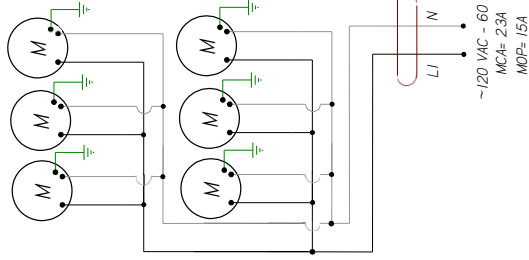

LOADING	
L1	120
L2	150
L3	

NOTE: CASE MUST BE GROUNDED

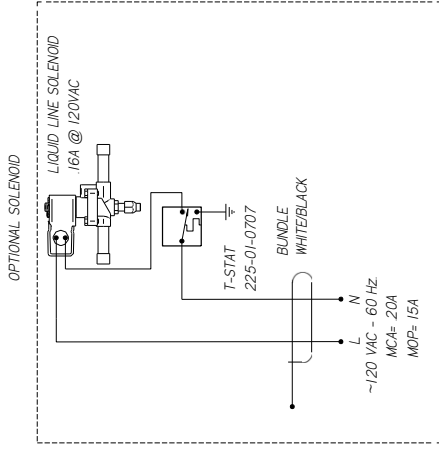

REV	EN	DATE	REVISION DESCRIPTION	REV BY	CHKD BY	APPR BY
A	ECN-CAP-0002200	28/06/2013	RELEASED TO PRODUCTION	CB	CB	CB
B	ECN-COD-0015276	20/02/2017	NEW LOGOS	CB	CB	CB

**HUSSMANN**  
DIAGRAM-IYI-6X8I-R

MATERIAL - NA  
DATE DRAWN - 6-3-16  
DRAWN BY - CRAIG BOOREY  
REVIEWED BY - CRAIG BOOREY  
APPROVED BY - CRAIG BOOREY  
UNLESS OTHERWISE SPECIFIED DIMENSIONS ARE IN INCHES  
TOLERANCES ARE:  
THIRD ANGLE PROJECTION  
DECIMALS .XX ±0.3 .XXX ±0.10 ANGLES ± 2°

ECN-CAP-0002200  
REF -  
SHEET 1 OF 1

3008179 | B

NOTES:  
CASE MUST BE GROUNDED  
WHEN PASSING WIRES THROUGH METAL HOLES A GROMMET MUST BE USED

CIRCUIT #1

LOADING	
120V	
L1	
L2	
L3	

LIGHT CIRCUIT  
66A 712W @ 120V

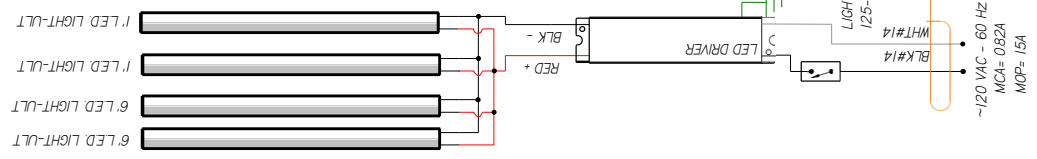

REVISION HISTORY

REV	EN	DATE	DESCRIPTION	REV BY	CHK BY	APP BY
A	ECN-CAP-0003964	20160918	RELEASED TO PRODUCTION	CB	CB	CB
B	ECN-COR-0015276	20220207	NEW LIGHTS	CB	CB	CB

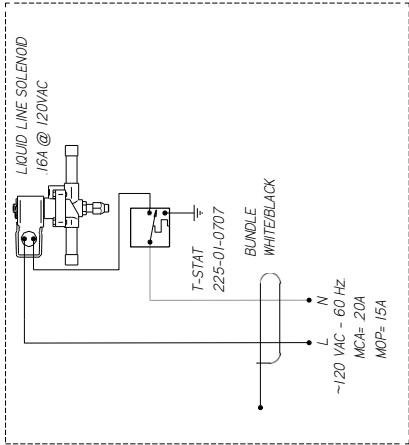
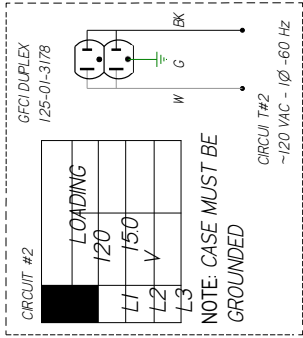

ANTI-SWEAT HEATER  
50W 0.83A @ 120VAC  
111 0497590  
111 0495007

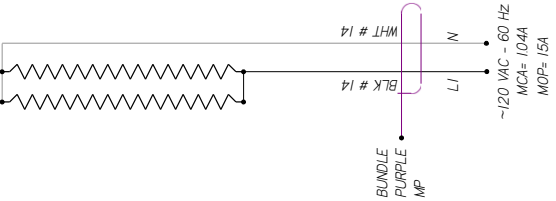

EVAPORATOR FAN  
12W 0.30A @ 120VAC  
1101 0477655

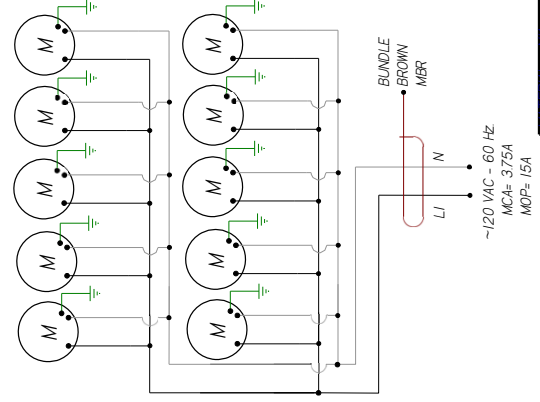

MATERIAL - IVA

DATE DRAWN - 9-8-16  
DRAWN BY - CRAIG BOOREY  
REVIEWED BY - CRAIG BOOREY  
APPROVED BY - CRAIG BOOREY  
UNLESS OTHERWISE SPECIFIED DIMENSIONS ARE IN INCHES  
TOLERANCES ARE:  
THIRD ANGL  
E  
PROJECTION

HUSSMANN

DIAGRAM-1Y1-  
6X121-R

3014692



NOTES:  
CASE MUST BE GROUNDED  
WHEN PASSING WIRES THROUGH METAL HOLES A GROMMET MUST BE USED

CIRCUIT #1

LOADING	120V
L1	2.63
L2	
L3	

**NOTE: CASE MUST BE GROUNDED**

EVAPORATOR FAN  
12W 0.30A @ 120VAC  
(6) 0477655

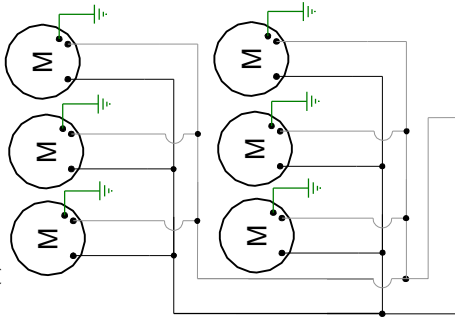

BUNDLE BROWN MBR  
L1 N  
L1 N  
~120 VAC - 50/60 Hz  
MCA= 2.3A  
MOP= 15A

LIGHT CIRCUIT  
0.41A 44.6W@120V

CANOPY LIGHTS

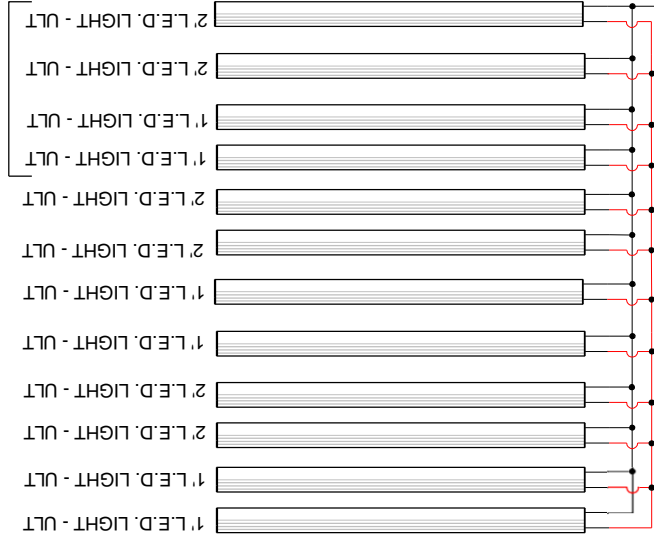

BUNDLE ORANGE MO  
WHT#14 N  
BLK#14 L1  
~120 VAC - 50/60 Hz  
MCA= 0.51  
MOP= 15A

CIRCUIT #2	LOADING	120 V
L1	15.0	
L2		
L3		

**NOTE: CASE MUST BE GROUNDED**

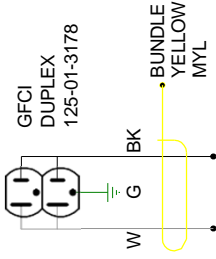

CIRCUIT #2  
~120 VAC - 1Ø - 60 Hz

ANTI-SWEAT HEATER  
50W .42A @ 120 VAC  
0497590

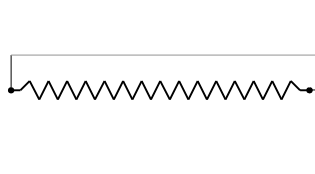

BUNDLE PURPLE MP  
WHT # 14 N  
BLK # 14 L1  
~120 VAC - 50/60 Hz  
MCA= 0.46A  
MOP= 15A

OPTIONAL

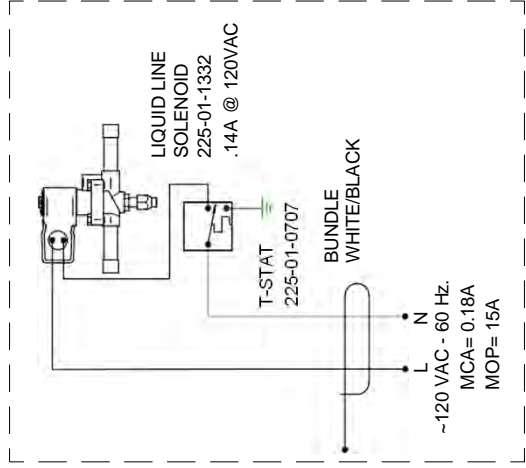

LIQUID LINE SOLENOID  
225-01-1332  
.14A @ 120VAC

T-STAT 225-01-0707  
BUNDLE WHITE/BLACK  
L N  
~120 VAC - 60 Hz.  
MCA= 0.18A  
MOP= 15A

CIRCUIT #1

120V	
1-3-2	



LIGHT CIRCUIT  
70A 75.2W @ 120V

ANTI-SWEAT HEATER  
@ 120 VAC  
C495006 30W 0.25A  
C495007 40W 0.42A

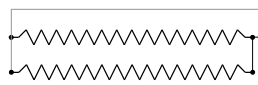

~120 VAC - 50/60 HZ  
MCA= 0.84A  
MOP= 15A

BUNDLE PURPLE  
MP

EVAPORATOR FAN  
12W 0.30A @ 120VAC (6)  
C4177655

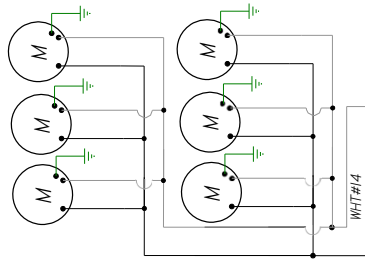

~120 VAC - 50/60 HZ  
MCA= 0.23A  
MOP= 15A

LIGHT SWITCH  
125-01-0307

BUNDLE ORANGE  
MO

~120 VAC - 50/60 HZ  
MCA= 0.88A  
MOP= 15A

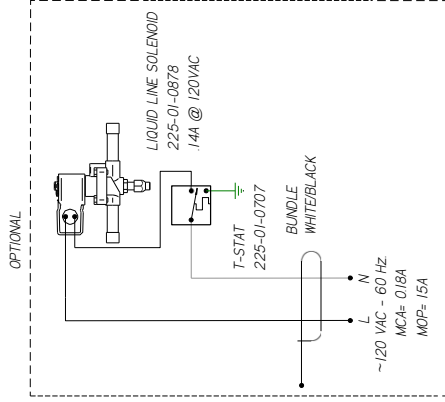

REV	ECN	DATE	REVISION DESCRIPTION	REV BY	CHK BY	APP BY
A	749653	20/03/06/28	NEW DIAGRAM	CB	CB	CB
B	749653	20/03/06/02	ANTI-SWEAT HEATER	CY	CY	CY
C	ECN-CR-0007700	20/07/05/10	REVISED ANTI-SWEAT HEATER	CY	CY	CY
D	ECN-CO-0016255	20/02/02/28	NEW LIGHTS & REVISED DRIVER	AL	CB	CB

MATERIAL - NA

DATE DRAWN - 8/28/13  
DRAWN BY - CRAIG BOOREY  
REVIEWED BY - CRAIG BOOREY  
APPROVED BY - CRAIG BOOREY  
UNLESS OTHERWISE SPECIFIED DIMENSIONS ARE IN INCHES  
TOLERANCES ARE:  
THIRD ANGL  
E  
PROJECTION

HUSSMANN

DIAGRAM -  
TY3-4X8I-

IH91354

DECIMALS .XX ±0.3 .XXX ±0.10

ANGLES ± 2°



NOTES:  
CASE MUST BE GROUNDED

REVISION HISTORY			
REV	EN	DATE	REV BY / APPR BY
1	ECN-CAP-0009958	2007/02/23	CB / CB
			RELEASED TO PRODUCTION

CIRCUIT #1	
LOADING	120V
L1	4.2
L2	
L3	

CIRCUIT #2	
LOADING	120V
L1	15.0
L2	
L3	

NOTE: CASE MUST BE GROUNDED

EVAPORATOR FAN  
12W 0.30A @ 120VAC IB1  
0477655

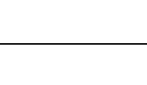
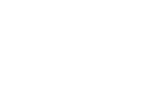
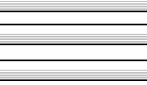
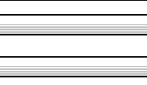
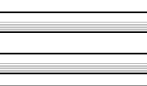
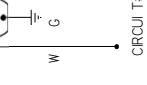
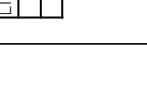
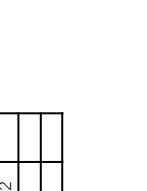
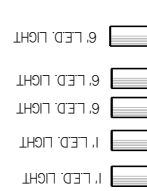
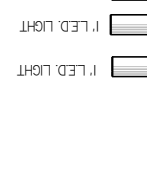
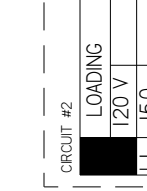
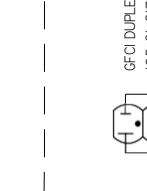
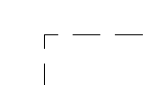

**HUSSMANN**  
DIAGRAM= IY3-4XT0-

DATE DRAWN - 10-23-17  
DRAWN BY - CRAIG BOOREY  
REVIEWED BY - CRAIG BOOREY  
APPROVED BY - CRAIG BOOREY  
SHEET 1 OF 1  
UNLESS OTHERWISE SPECIFIED DIMENSIONS ARE IN INCHES  
TOLERANCES ARE:  
DECIMALS .XX +0.3 .XXX +0.10  
ANGLES ± 2°

MATERIAL - NA  
ECN-CAP-0009958  
REF -  
SHEET 1 OF 1  
UNLESS OTHERWISE SPECIFIED DIMENSIONS ARE IN INCHES  
TOLERANCES ARE:  
DECIMALS .XX +0.3 .XXX +0.10  
ANGLES ± 2°

PROJECTION

3047530

A

NOTES:  
CASE MUST BE GROUNDED  
WHEN PASSING WIRES THROUGH METAL HOLES A GROMMET MUST BE USED



CIRCUIT #1	LOADING	120V	150V

REVISION HISTORY		DATE	DESCRIPTION	REV. BY	CHKD BY	APPR BY
REV	EN	2016/06/03	RELEASED TO PRODUCTION	CB	CB	CB
B	EDN-CD-0012626	2022/02/28	NEW LIGHTS & REMOVED DRIVER	AL	CB	CB

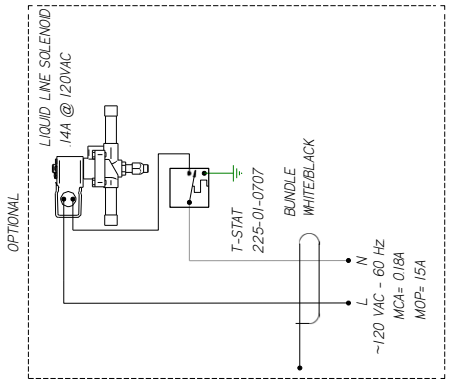
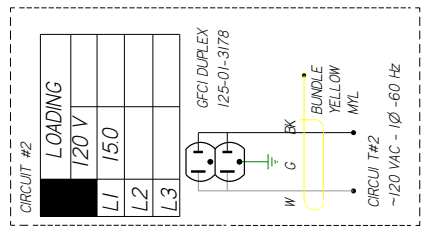
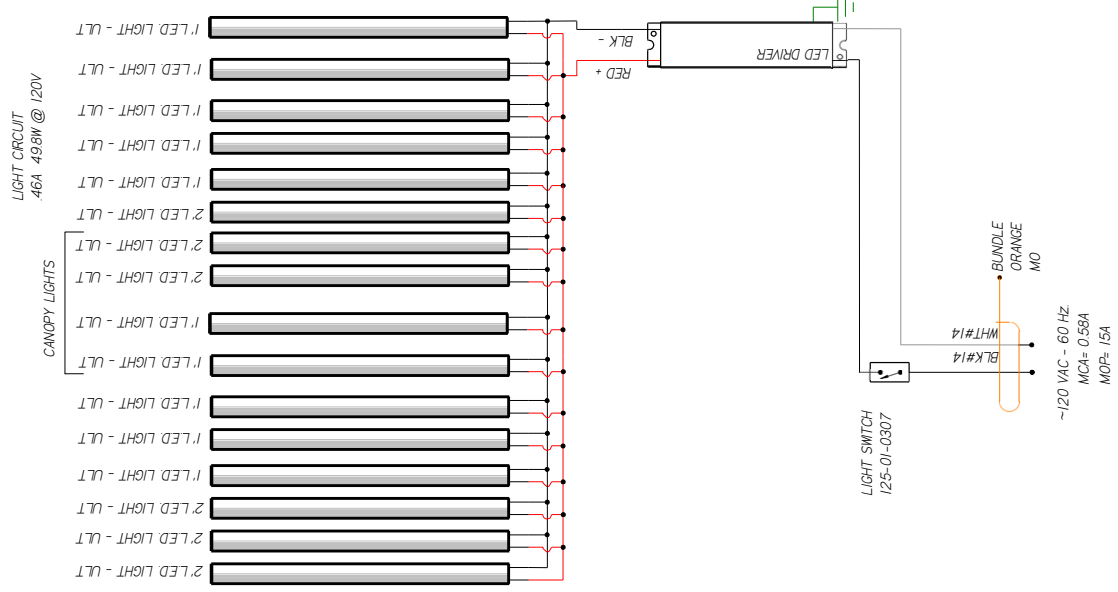

NOTES:  
CASE MUST BE GROUNDED  
WHEN PASSING WIRES THROUGH METAL HOLES A GROMMET MUST BE USED

**MATERIAL - N/A**

DATE DRAWN - 6-3-16  
DRAWN BY - CRAIG BOOREY  
REVIEWED BY - CRAIG BOOREY  
APPROVED BY - CRAIG BOOREY

**HUSSMANN**  
**DIAGRAM-1Y3-**  
**5X7I-R**

ECN-CAP-0002200  
REF -  
SHEET NO. 1  
UNLESS OTHERWISE SPECIFIED DIMENSIONS ARE IN INCHES  
TOLERANCES ARE:  
THIRD ANGL  
E  
PROJECTION

DECIMALS .XX ±0.3 .XXX ±0.0

ANGLES ± 2°

**3008177** | **B**

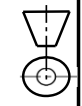

REVISION HISTORY		REV	ECN	DATE	DESCRIPTION	REV'D BY	CHK'D BY	APP'R BY
A	803263	2014/04/14	NEW DIAGRAM	NEW LIGHTS	CB	CB	CB	CB
B	ECN-000-0095235	2022/02/28			AL	CB	CB	CB

CIRCUIT #1	LOADING
120V	
150V	
180V	

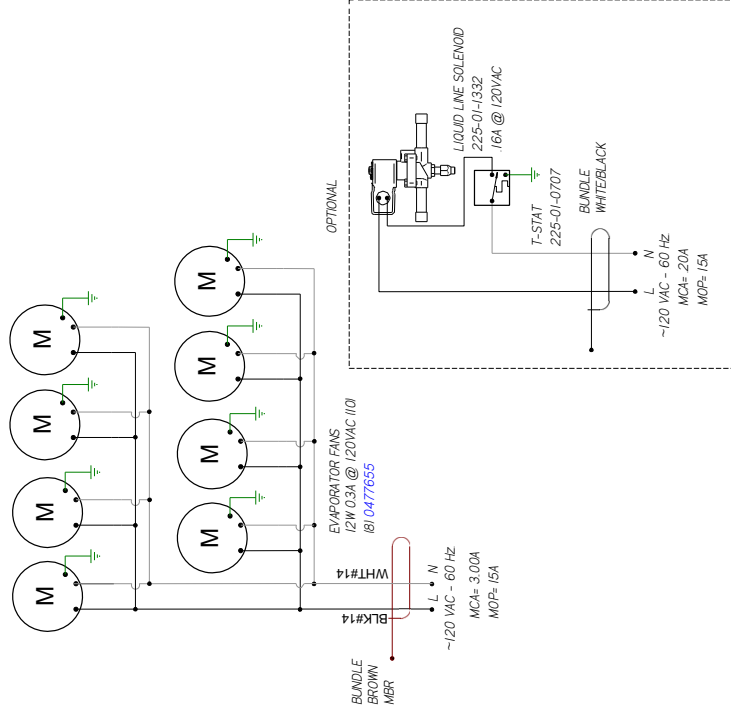
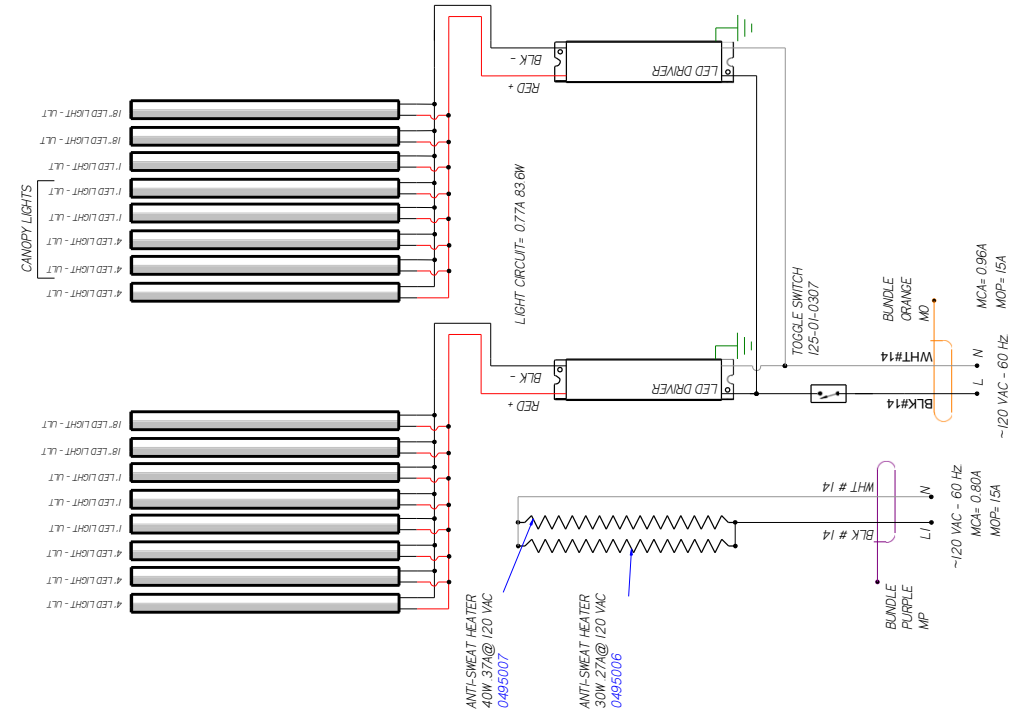
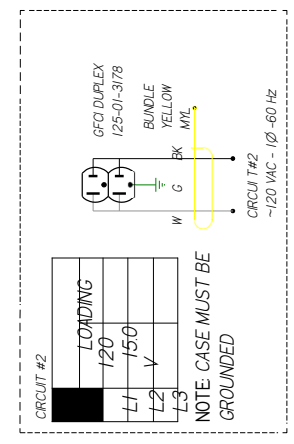

**HUSSMANN**  
DIAGRAM-1Y3-  
5X91-R

MATERIAL - NA  
DATE DRAWN - 4/11/14  
DRAWN BY - CRAIG BOOREY  
REVIEWED BY - CRAIG BOOREY  
APPROVED BY - CRAIG BOOREY  
UNLESS OTHERWISE SPECIFIED DIMENSIONS ARE IN INCHES  
TOLERANCES ARE:  
DECIMALS .XX ± 0.3 .XXX  
± 0.0 ANGL  
E  
PROJECTION

ECN# - 803263 REF - NEW  
DIAGRAM SHEET LOE T

2H00213 | B

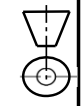

NOTES:  
CASE MUST BE GROUNDED

CIRCUIT #1

LOADING	120 V
L1	4.92

**NOTE: CASE MUST BE GROUNDED**

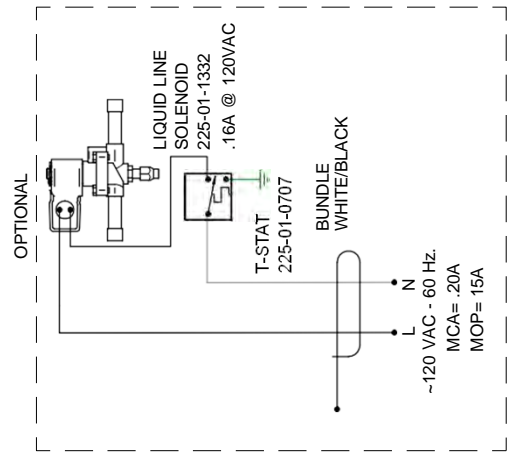
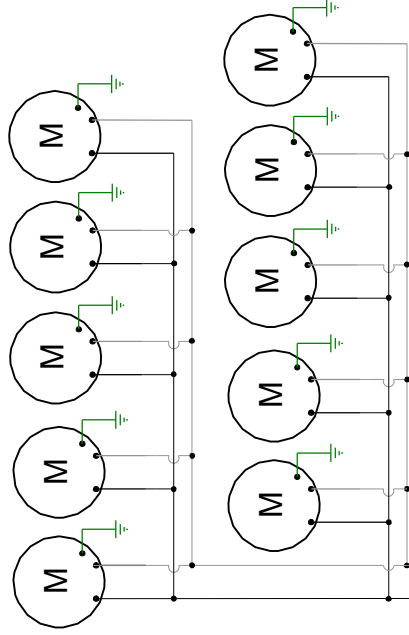
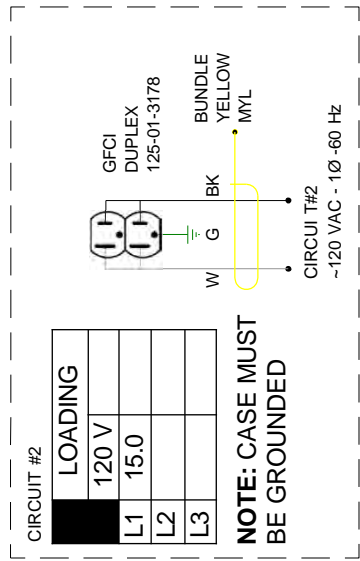

CANOPY LIGHTS

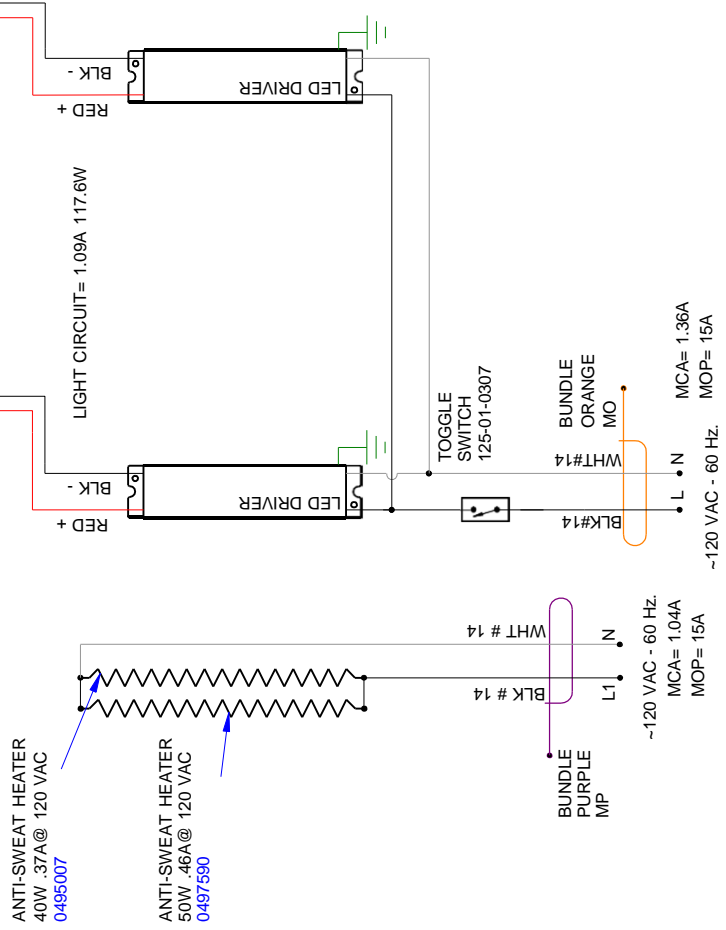

REVISIONS:

#	DESCRIPTION:
A	CN#720718
B	ECN-COD-0015255 NEW LIGHTS

DRAWN BY: CRAIG BOOREY	DATE: 5/6/13
CHECKED BY: CB	PRODUCTION ORDER #:
AL	FILE LOCATION:

PROJECT TITLE: **TY3-CASE**

DRAWING TITLE: **DIAGRAM-TY3-5X111-R**

REV	EN	DATE	REVISION DESCRIPTION	REV BY	CHK BY	APPR BY
1	ECN-CAP-0002200	2016/06/03	RELEASED TO PRODUCTION	CB	CB	CB

CIRCUIT #1	LOADING
L1	15.9
L2	
L3	

CIRCUIT #2	LOADING
L1	15.0
L2	
L3	

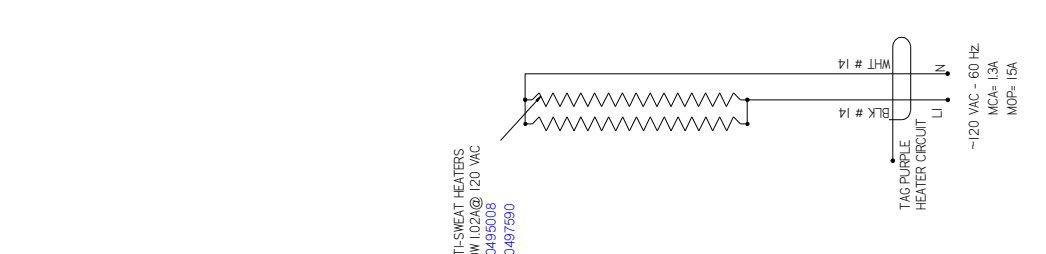
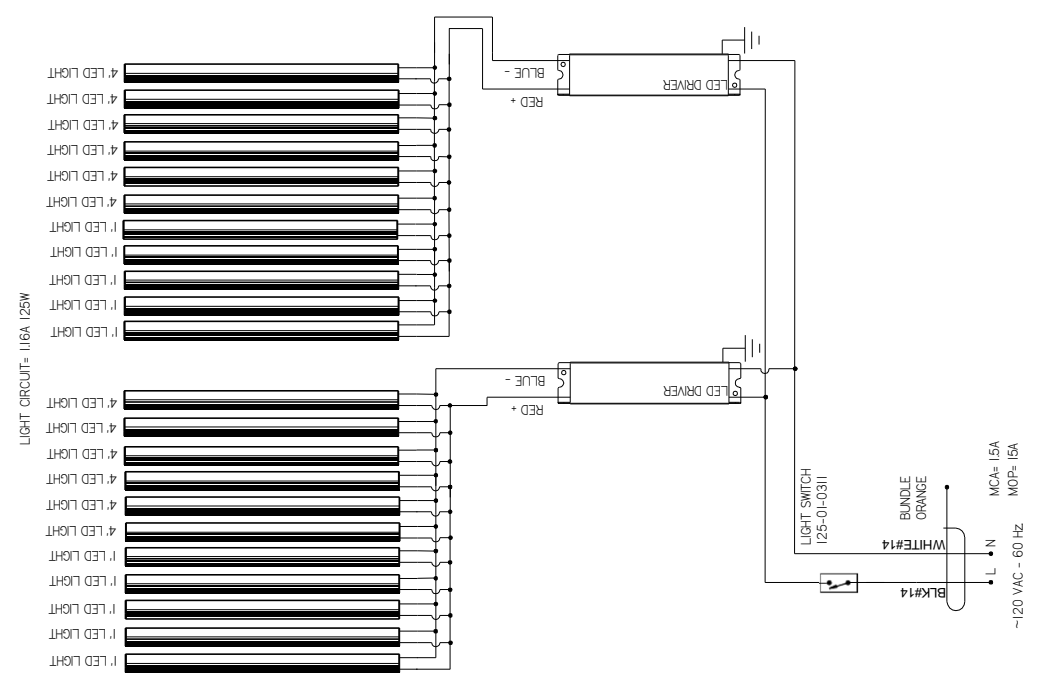
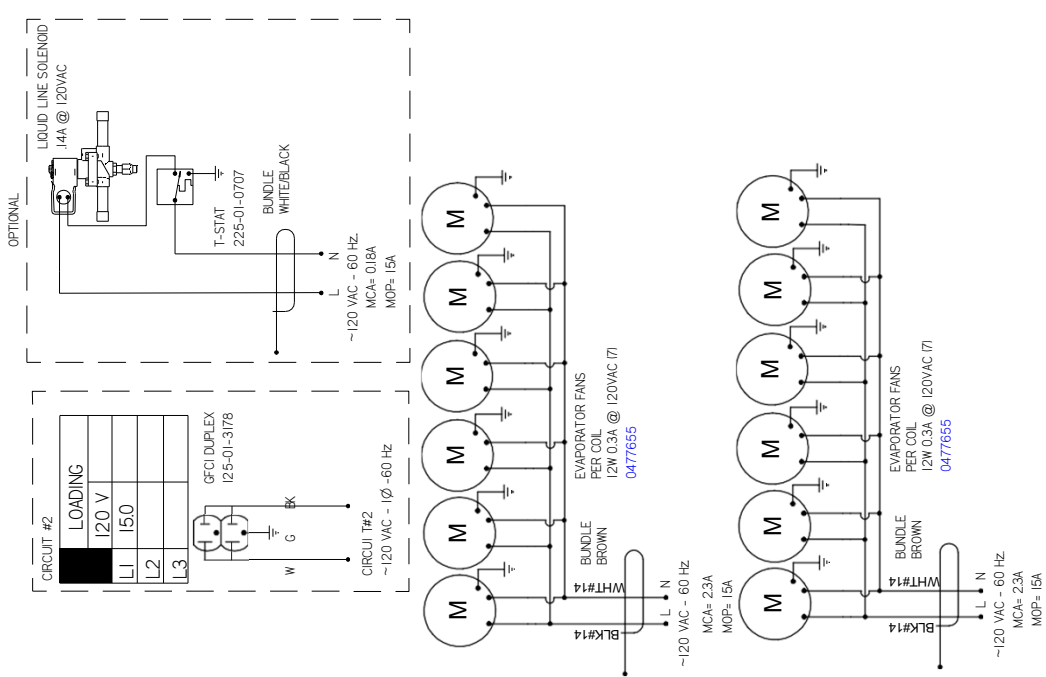

**HUSSMANN**  
**DIAGRAM=TY3-5X13I-**  
**R**

MATERIAL - NA  
 DATE DRAWN - 6-3-16  
 DRAWN BY - CRAIG BOOREY  
 REVIEWED BY - CRAIG BOOREY  
 APPROVED BY - CRAIG BOOREY  
 UNLESS OTHERWISE SPECIFIED DIMENSIONS ARE IN INCHES  
 TOLERANCES ARE:  
 DECIMALS .XX ±0.3 .XXX ±0.10  
 ANGLES ± 2°

ECN-CAP-0002200  
 REF -  
 SHEET 1 OF 1  
 THIRD

3008175  
 A

PRODUCTION

NOTES:  
 CASE MUST BE GROUNDED  
 WHEN PASSING WIRES THROUGH METAL HOLES A GROMMET MUST BE USED

CIRCUIT #1	
LOADING	
120V	
L1	
L2	
L3	
L4	

REV	EN	DATE	REVISION DESCRIPTION	REV BY	CHKD BY	APPR BY
A		2016/08/17	RELEASED TO PRODUCTION	CB	CB	CB

LIGHT CIRCUIT  
098A 1056W @ 120V

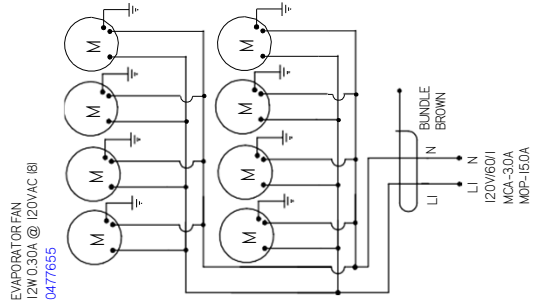
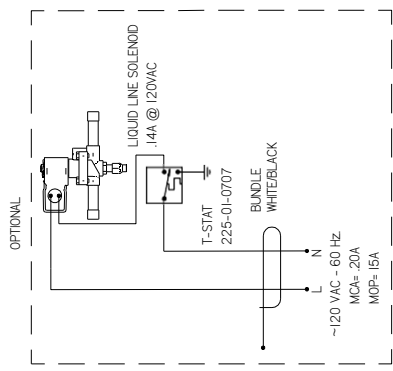

EVAPORATOR FAN  
12W @ 30A @ 120VAC (Ø)  
0477665

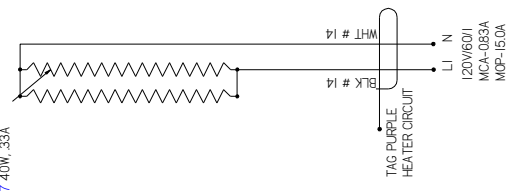
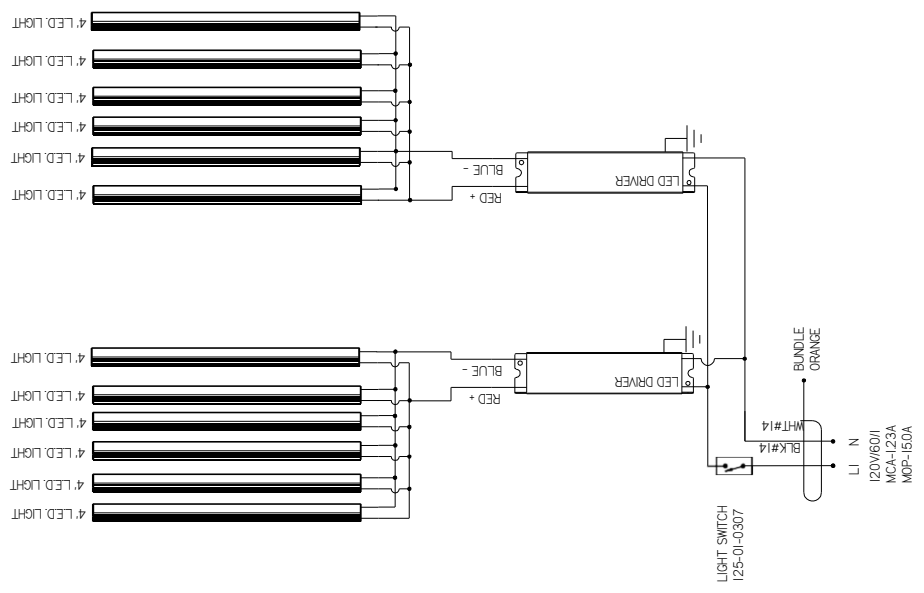

TAG PURPLE  
HEATER CIRCUIT

MATERIAL - NA  
DATE DRAWN - 8-17-16  
DRAWN BY - CRAIG BOOREY  
REVIEWED BY - CRAIG BOOREY  
APPROVED BY - CRAIG BOOREY  
UNLESS OTHERWISE SPECIFIED DIMENSIONS ARE IN INCHES  
TOLERANCES ARE:  
DECIMALS .XX +0.3 .XXX +0.10  
ANGLES ± 2°

ECN-CAP-10003235  
REF -  
SHEET 1 OF 1  
THIRD

**Hussmann**  
DIAGRAM-1Y3-6X8C-R

3013478

PROJECTION

A

NOTES:  
CASE MUST BE GROUNDED  
WHEN PASSING WIRES THROUGH METAL HOLES A GROMMET MUST BE USED

CANOPY LIGHTS

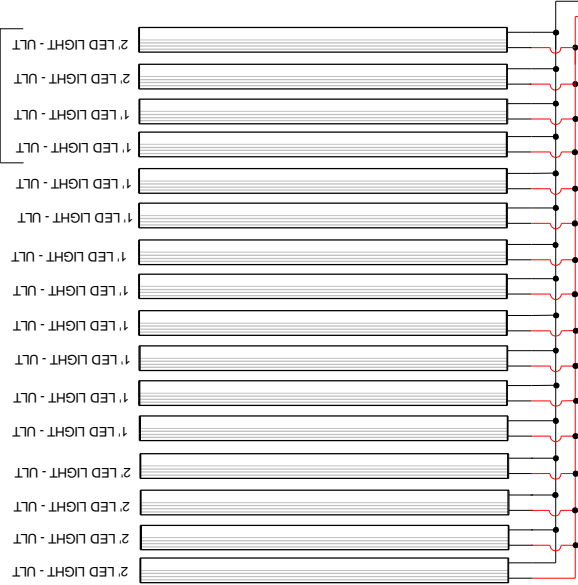

ANTI-SWEAT HEATER  
50W .42A @ 120 VAC  
0497590

LIGHT CIRCUIT= 0.46A 49.8W

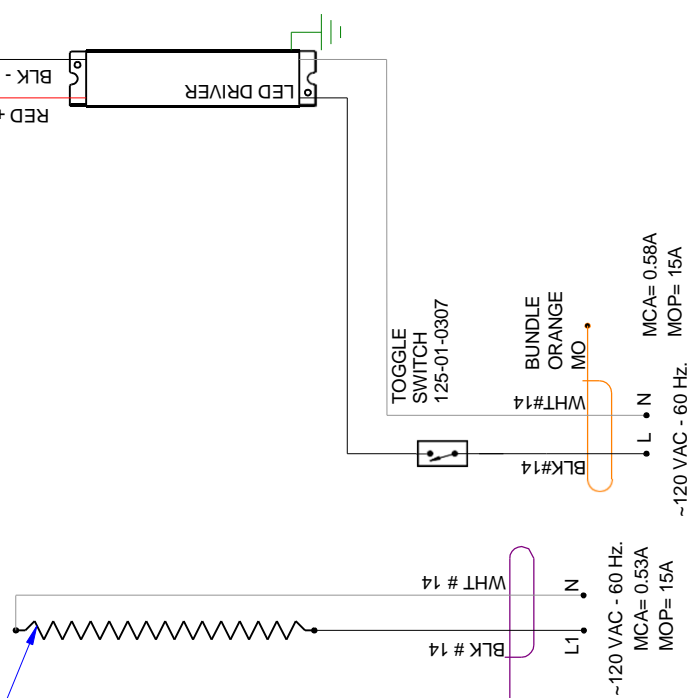

~120 VAC - 60 Hz.  
MCA= 0.53A  
MOP= 15A

~120 VAC - 60 Hz.  
MCA= 0.58A  
MOP= 15A

CIRCUIT #2

LOADING	
120 V	
L1	15.0
L2	
L3	

**NOTE: CASE MUST BE GROUNDED**

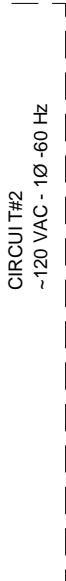

EVAPORATOR FANS  
12W 0.3A @ 120VAC  
(6) 0477655

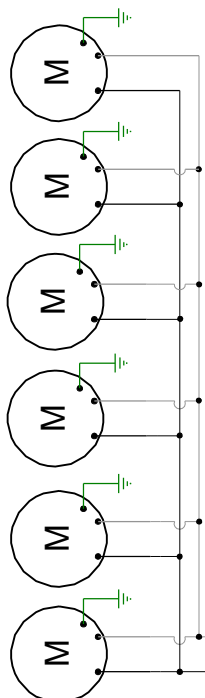

BUNDLE BROWN MBR  
~120 VAC - 60 Hz.  
MCA= 2.25A  
MOP= 15A

CIRCUIT #1

LOADING	
120 V	
L1	2.7

**NOTE: CASE MUST BE GROUNDED**

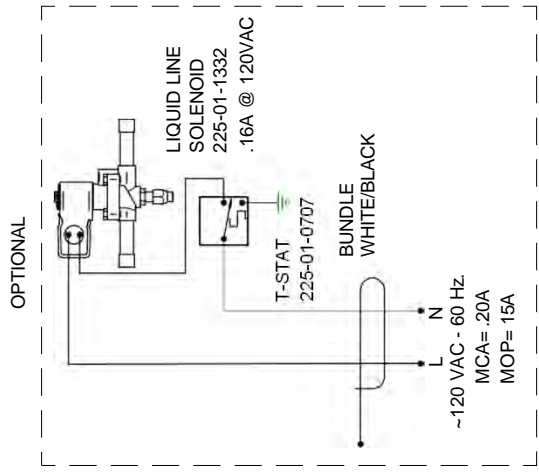
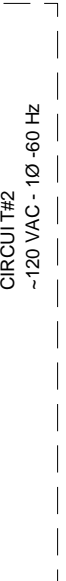
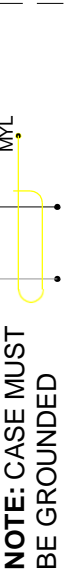

OPTIONAL

LIQUID LINE SOLENOID  
225-01-1332  
.16A @ 120VAC

T-STAT  
225-01-0707

BUNDLE WHITE/BLACK

~120 VAC - 60 Hz.  
MCA= .20A  
MOP= 15A

REVISIONS:

#	DESCRIPTION:	DATE:	BY:
A	CM# 720718	5/6/13	CB
B	ECN-COD-0015255 NEW LIGHTS	2/28/22	AL

DRAWN BY: CRAIG BOOREY  
CHECKED BY: \_\_\_\_\_  
DATE: 5/6/13  
PRODUCTION ORDER #:  
FILE LOCATION:

PROJECT TITLE: **TY3-CASE**  
DRAWING TITLE:  
**DIAGRAM-TY3-6X81-R**

REVISION HISTORY			
REV	EN	DATE	DESCRIPTION
A	ECN-CAP-0003968	2016/01/13	RELEASED TO PRODUCTION
B	ECN-CAP-0014946	2018/01/13	REVISED ANTI-SWEAT HEATER

CIRCUIT #1	LOADING	120V	150V	180V

CIRCUIT #2	LOADING	120V	150V	180V
L1				
L2				
L3				

NOTE: CASE MUST BE GROUNDED

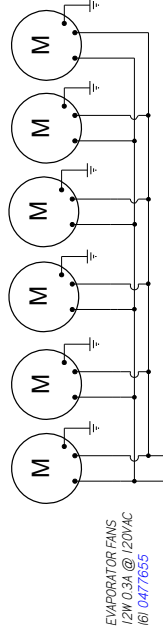
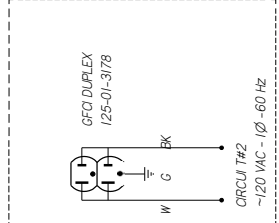

EVAPORATOR FANS  
1/2W 0.3A @ 120VAC  
161 04171655

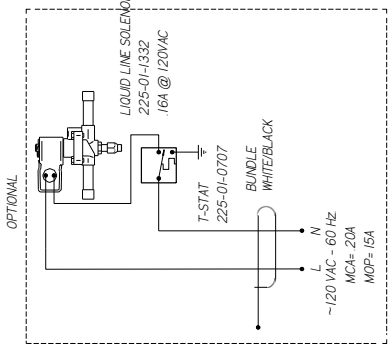

OPTIONAL

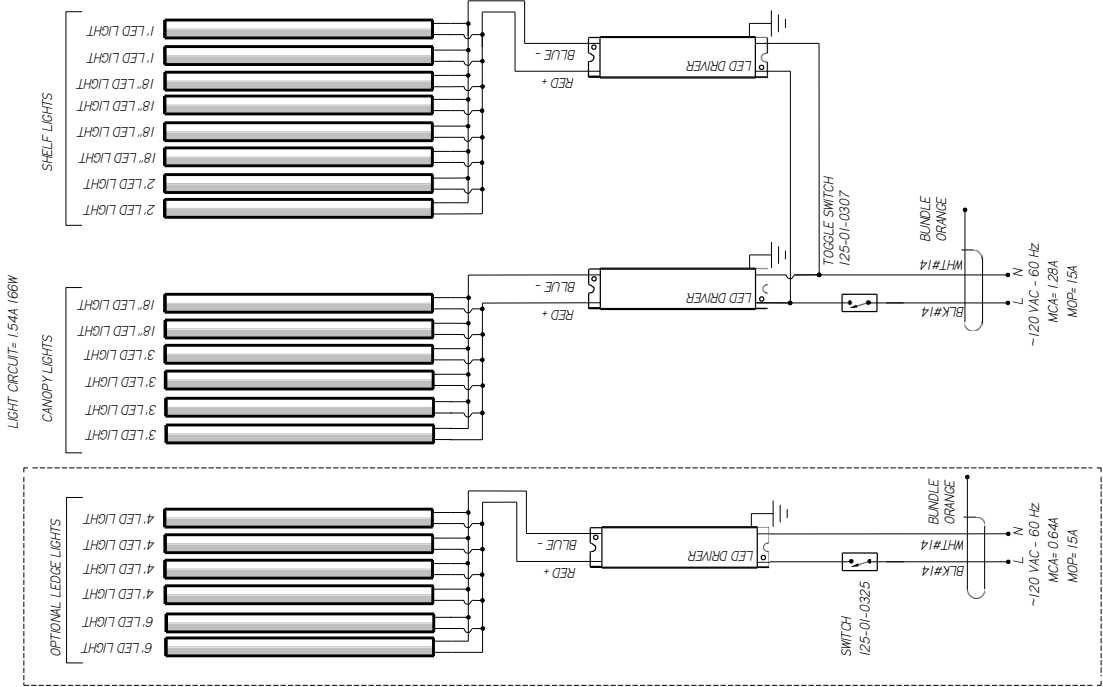

LIGHT CIRCUIT= 1.544/168W

ANTI-SWEAT HEATER  
60W 50A @ 120 VAC  
0495008

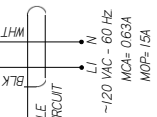

**HUSSMANN**  
DIAGRAM-  
TY3ECSQ- 6X81-R

MATERIAL - NA  
DATE DRAWN - 10-13-16  
DRAWN BY - CRAIG BOOREY  
REVIEWED BY - CRAIG BOOREY  
APPROVED BY - CRAIG BOOREY  
UNLESS OTHERWISE SPECIFIED DIMENSIONS ARE IN INCHES  
TOLERANCES ARE:  
DECIMALS .XX ±0.3 .XXX  
±0.0

ECN-CAP-0003968 REF -  
SHEET 1 OF 1  
THIRD ANGLE PROJECTION

301718 | B

NOTES:  
CASE MUST BE GROUNDED  
WHEN PASSING WIRES THROUGH METAL HOLES A GROMMET MUST BE USED



CIRCUIT #1

LOADING	
120 V	
L1	3.75

**NOTE: CASE MUST BE GROUNDED**

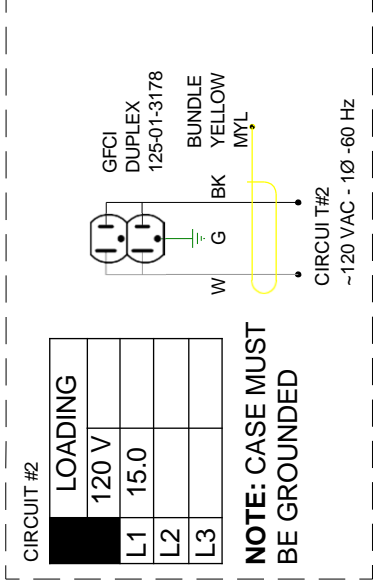

ANTI-SWEAT HEATER  
120 VAC  
(1) 0495007 40W, .33A  
(1) 0495006 30W, .25A

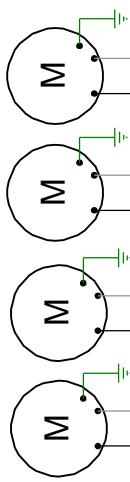

EVAPORATOR FANS  
PER COIL  
12W 0.3A @ 120VAC  
(4) 0477655

~120 VAC - 60 Hz.  
MCA= 1.5A  
MOP= 15A

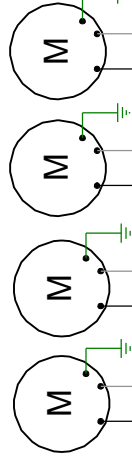

EVAPORATOR FANS  
PER COIL  
12W 0.3A @ 120VAC  
(4) 0477655

~120 VAC - 60 Hz.  
MCA= 1.5A  
MOP= 15A

BUNDLE PURPLE MP  
WHT # 14  
BLK # 14  
L1 N  
~120 VAC - 50/60 Hz  
MCA= .93A  
MOP= 15A

CANOPY LIGHTS

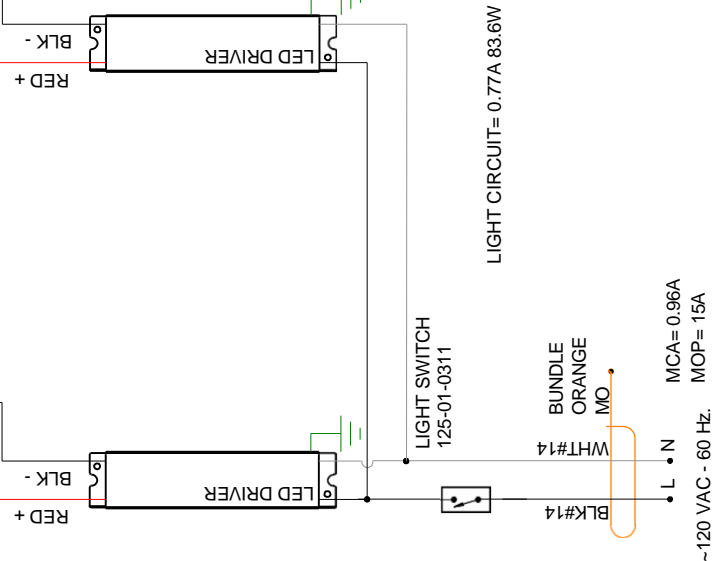
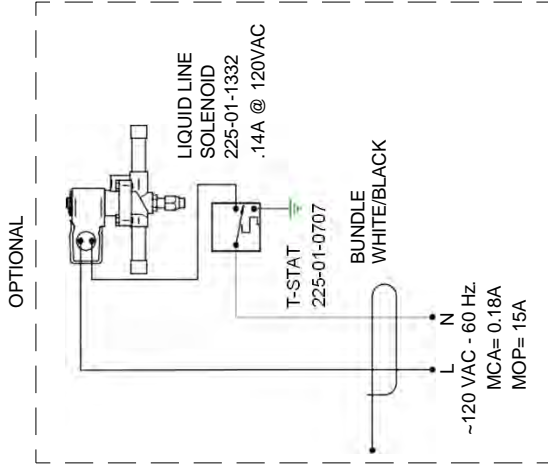
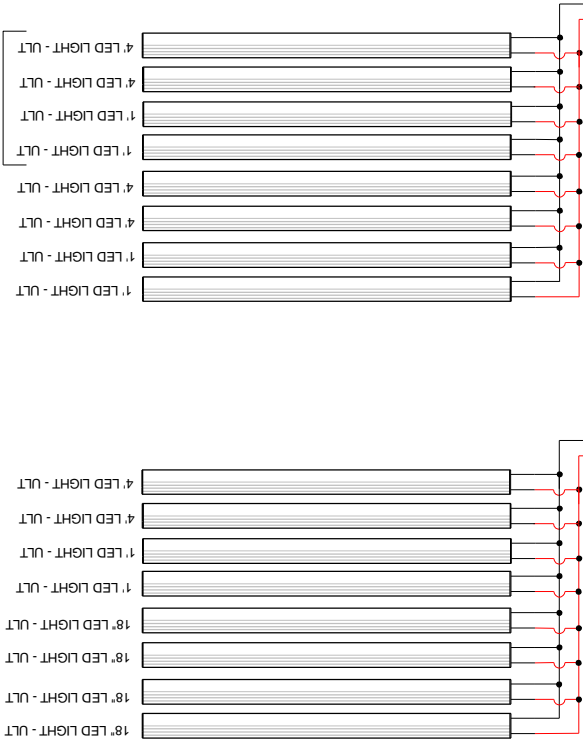

LIGHT CIRCUIT= 0.77A 83.6W

~120 VAC - 60 Hz.  
MCA= 0.96A  
MOP= 15A

CIRCUIT #2

LOADING	
120 V	
L1	15.0
L2	
L3	

**NOTE: CASE MUST BE GROUNDED**

**HUSSMANN**  
Hussmann Corporation, Intl.  
13770 Ramona Avenue  
Chino, CA. 91710  
(909)-590-4910 Lic.#: 644406

REVISIONS:  
# DESCRIPTION: DATE: BY: CB  
C CN#696786 ADDED OPTIONAL SOLENOID 3/22/13 CB  
D CN#980241 REVISED ANTI-SWEAT HTR 4/16/15 CB  
E ECN-COD-0015255 NEW LIGHTS, REMOVED DRIVER 2/28/22 AL

DRAWN BY: CRAIG BOOREY  
CHECKED BY: DATE: 8/10/12  
PRODUCTION ORDER #:  
FILE LOCATION:

PROJECT TITLE: TY3-CASE  
DRAWING TITLE: DIAGRAM-TY3-6X101-R

DRAWING #: 1H78139

PAGE 1 OF 1

REVISION HISTORY			
REV	EN	DATE	DESCRIPTION
1	ECN-CAP-0009958	2017/02/20	RELEASED TO PRODUCTION
REV BY	CHKD BY	APPR BY	CS
CS	CS	CS	CS

CIRCUIT #1	
LOADING	120V
L1	4.9
L2	
L3	

9.3A 100.3W @ 120V

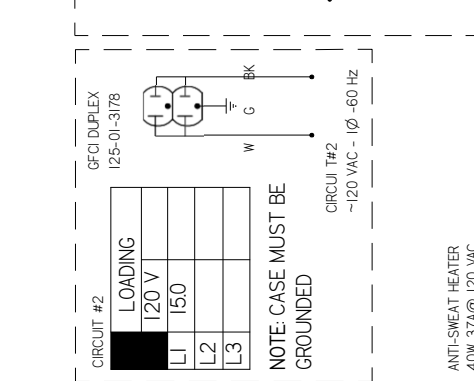

CIRCUIT #2	
LOADING	120 V
L1	15.0
L2	
L3	

NOTE: CASE MUST BE GROUNDED

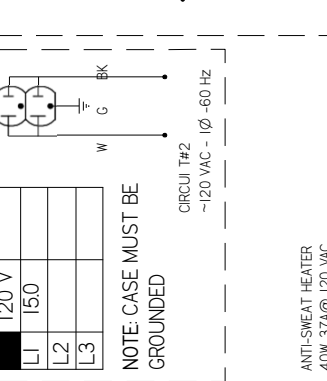

**HUSSMANN**  
DIAGRAM=TY3-6X1Z-R

MATERIAL - NA  
DATE DRAWN - 10-20-17  
DRAWN BY - CRAIG BOOREY  
REVIEWED BY - CRAIG BOOREY  
APPROVED BY - CRAIG BOOREY  
UNLESS OTHERWISE SPECIFIED DIMENSIONS ARE IN INCHES  
TOLERANCES ARE:  
DECIMALS .XX +0.3 .XXX +0.10  
ANGLES ± 2°

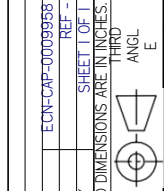

3047528 A

NOTES:  
CASE MUST BE GROUNDED  
WHEN PASSING WIRES THROUGH METAL HOLES A GROMMET MUST BE USED

CIRCUIT #1	LOADING
	120V
	L1 7.6

LIGHT CIRCUIT  
166A 1798W @ 120V

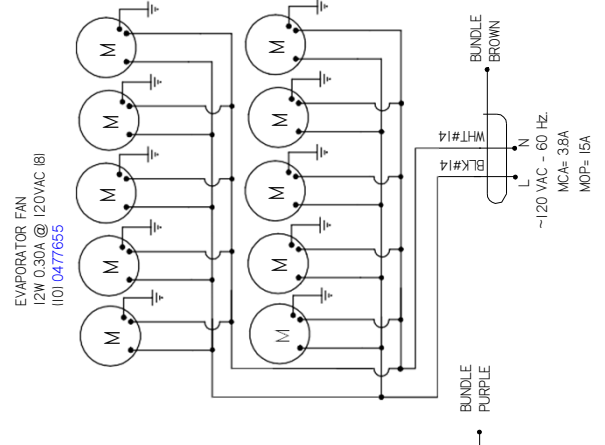
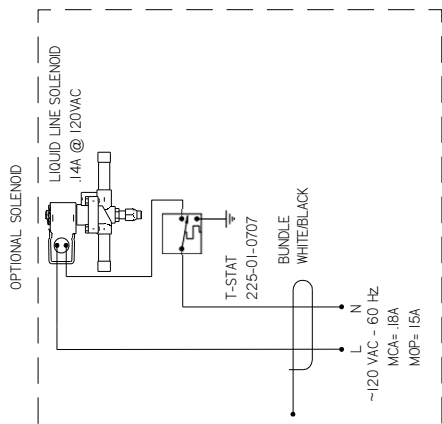
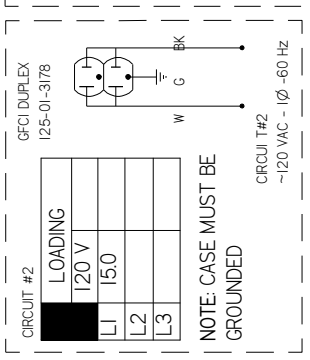
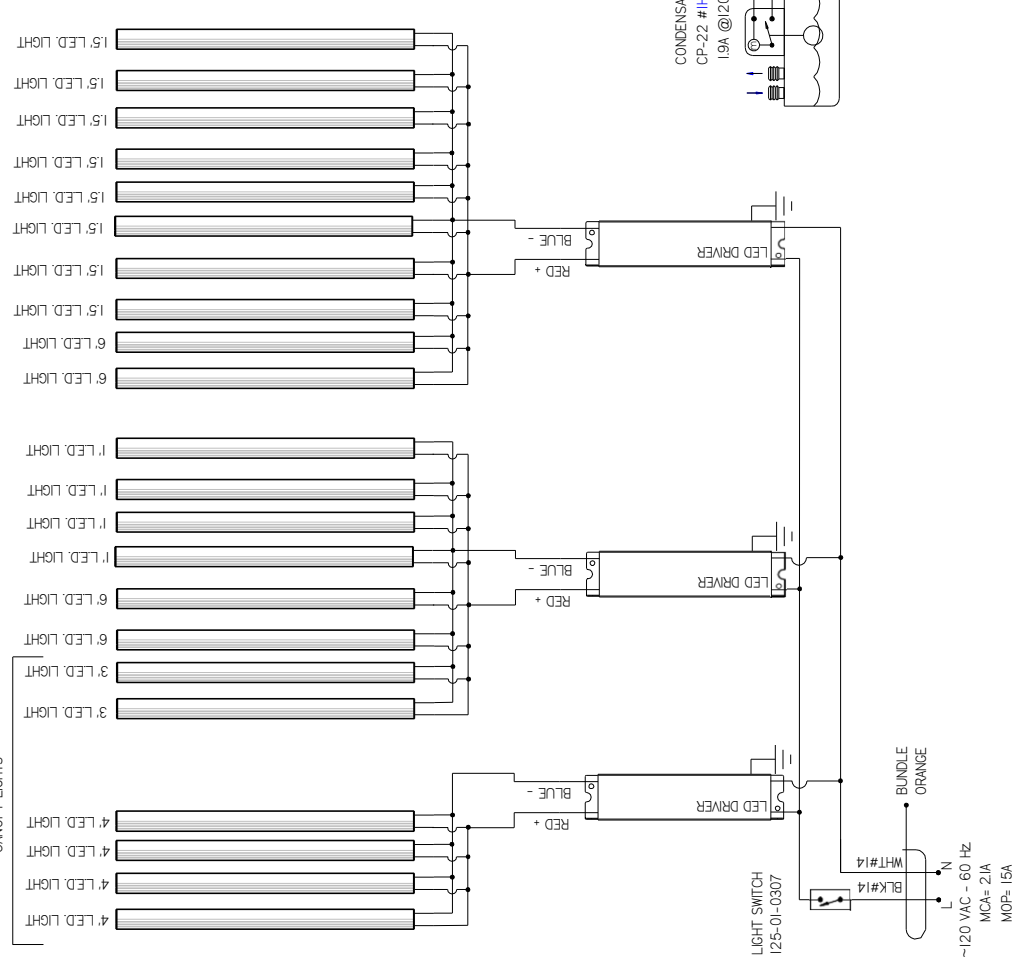

**HUSSMANN**  
DIAGRAM-1Y3ECSQ-6X12-R

MATERIAL - NA  
DATE DRAWN - 11-2-17  
DRAWN BY - CRAIG BOOREY  
REVIEWED BY - CRAIG BOOREY  
APPROVED BY - CRAIG BOOREY  
UNLESS OTHERWISE SPECIFIED DIMENSIONS ARE IN INCHES  
TOLERANCES ARE:  
DECIMALS .XX +0.3 .XXX +0.10  
ANGLES ± 2°

ECN-CAP-0009960  
REF -  
SHEET 1 OF 1  
THIRD  
ANG  
E

3048459

PRODUCTION

NOTES:  
CASE MUST BE GROUNDED  
WHEN PASSING WIRES THROUGH METAL HOLES A GROMMET MUST BE USED

CIRCUIT #1

LOADING	
120 V	
L1	5.8

**NOTE: CASE MUST BE GROUNDED**

CANOPY LIGHTS

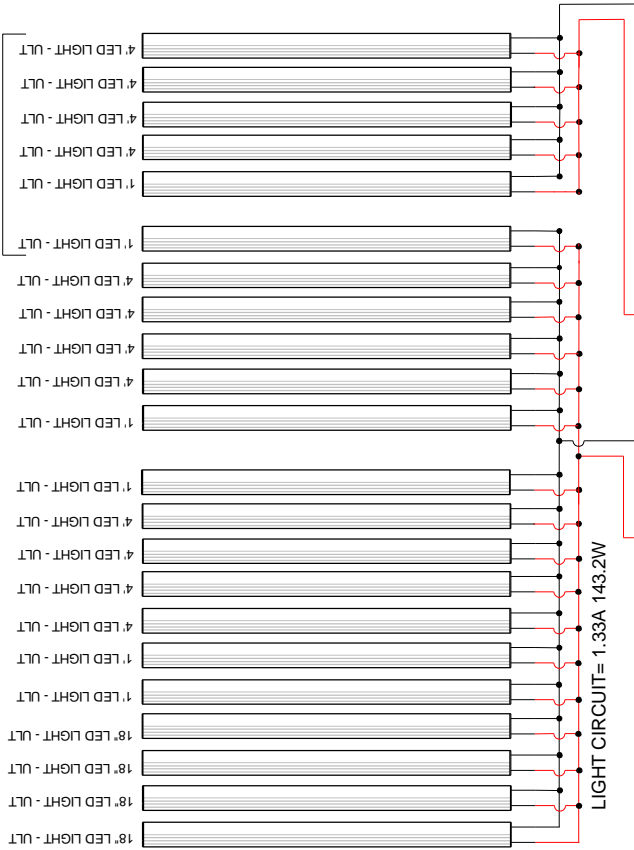

LIGHT CIRCUIT= 1.33A 143.2W

ANTI-SWEAT HEATER  
60W .50A @ 120 VAC  
0495008

ANTI-SWEAT HEATER  
50W .42A @ 120 VAC  
0497590

~120 VAC - 60 Hz.  
MCA= 1.15A  
MOP= 15A

~120 VAC - 60 Hz.  
MCA= 1.66A  
MOP= 15A

~120 VAC - 60 Hz.  
MCA= 2.3A  
MOP= 15A

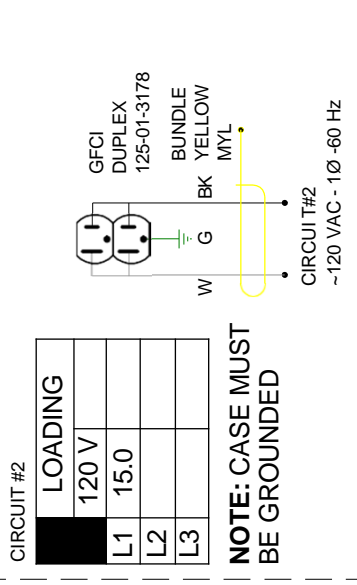

CIRCUIT #2

LOADING	
120 V	
L1	15.0
L2	
L3	

**NOTE: CASE MUST BE GROUNDED**

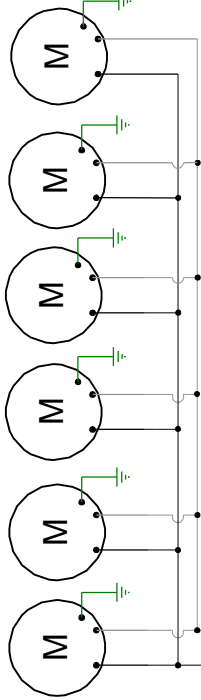

EVAPORATOR FANS  
PER COIL  
12W 0.3A @ 120VAC  
(6) 0477655

~120 VAC - 60 Hz.  
MCA= 2.3A  
MOP= 15A

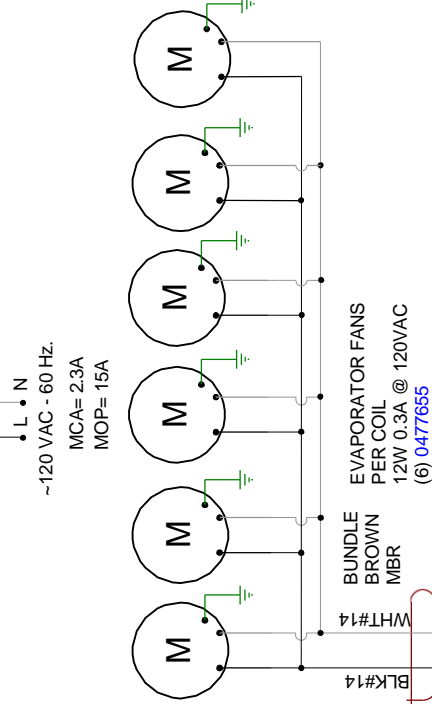

EVAPORATOR FANS  
PER COIL  
12W 0.3A @ 120VAC  
(6) 0477655

~120 VAC - 60 Hz.  
MCA= 2.3A  
MOP= 15A

OPTIONAL

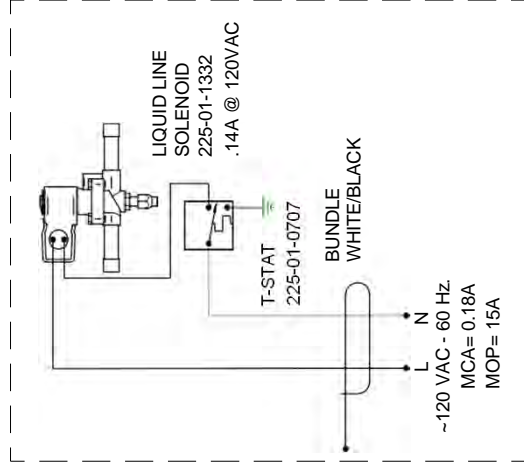

LIQUID LINE  
SOLENOID  
225-01-1332  
.14A @ 120VAC

T-STAT  
225-01-0707

BUNDLE  
WHITE/BLACK

~120 VAC - 60 Hz  
MCA= 0.18A  
MOP= 15A

REVISIONS:

#	DESCRIPTION:
A	CN#634531
B	CN#696786 Added AS Htrs. & Solenoid
C	ECN-COD-0015255 NEW LIGHTS

DATE:	BY:
8/7/12	CB
3/21/13	CB
2/28/22	AL

DRAWN BY: CRAIG BOOREY  
CHECKED BY:  
DATE: 8/8/12  
PRODUCTION ORDER #: 920172  
FILE LOCATION:

PROJECT TITLE: TY3-ISLAND CASE

DRAWING TITLE:  
DIAGRAM-TY3-6X141-R

DRAWING #: 1H77864

REVISION HISTORY		REV. BY	CHG. BY	APPR. BY
REV	EN	DATE	DESCRIPTION	RELEASED TO PRODUCTION
1	A	20080205	ECON-CAP-001188	

CIRCUIT #1	LOADING
	120V
	L1
	L2
	L3

CIRCUIT #2	LOADING
	120V
	L1
	L2
	L3

CIRCUIT #2	LOADING
	120V
	L1
	L2
	L3

CIRCUIT #2	LOADING
	120V
	L1
	L2
	L3

CIRCUIT #2	LOADING
	120V
	L1
	L2
	L3

CIRCUIT #2	LOADING
	120V
	L1
	L2
	L3

CIRCUIT #2	LOADING
	120V
	L1
	L2
	L3

CIRCUIT #2	LOADING
	120V
	L1
	L2
	L3

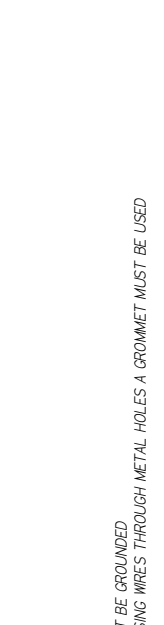
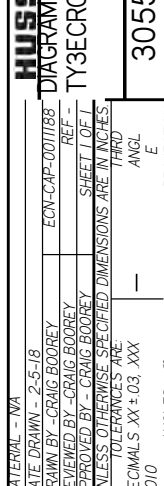
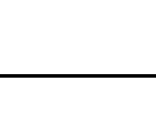
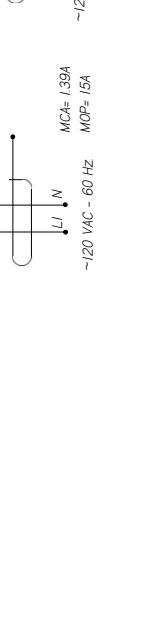
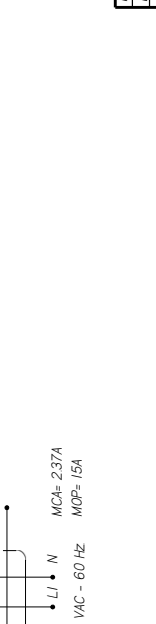
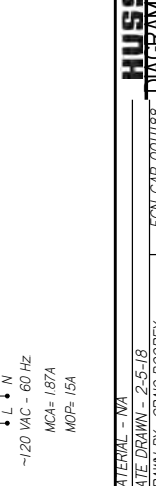
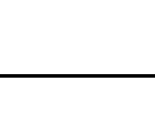
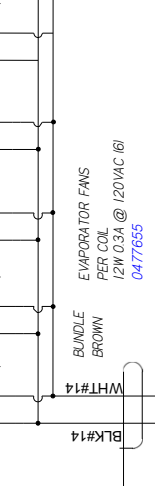
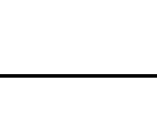
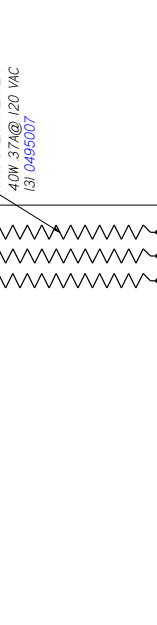
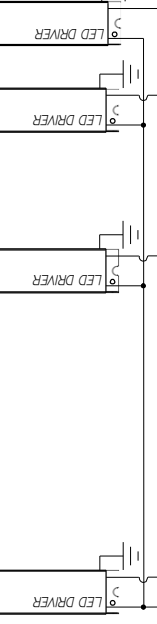
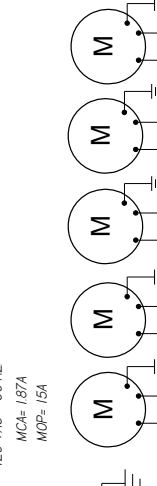
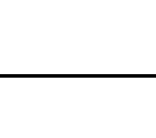
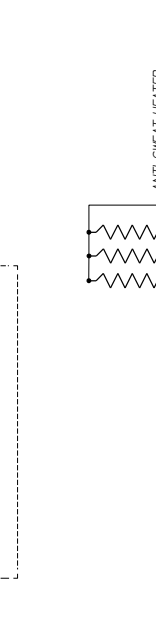
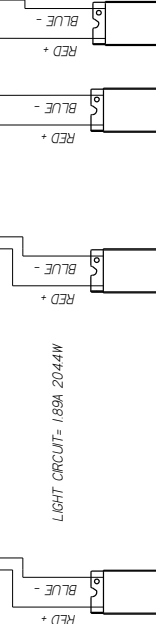
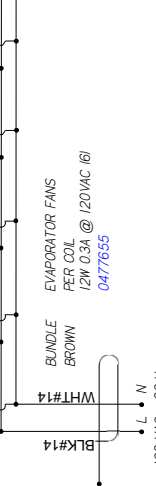
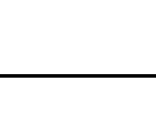
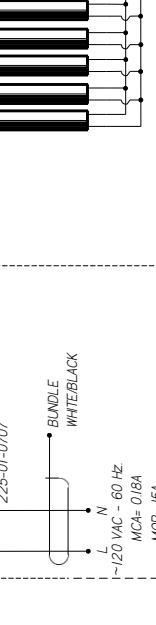
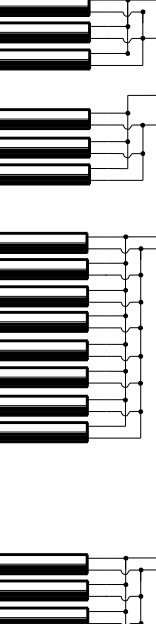
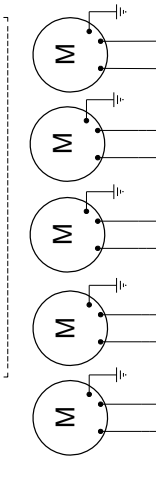
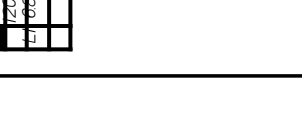
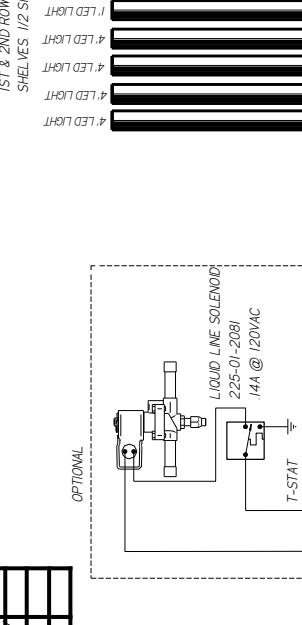
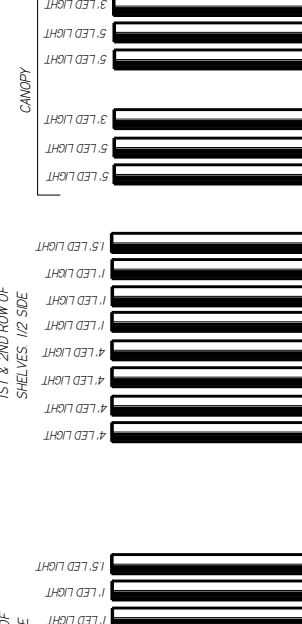
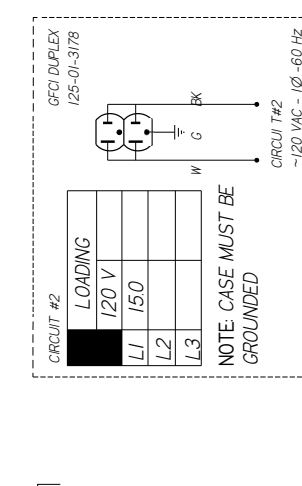

**HUSSMANN**  
DIAGRAM-  
TY3ECRC- 6X141-R

MATERIAL - N/A  
DATE DRAWN - 2-5-18  
DRAWN BY - CRAIG BOOREY  
REVIEWED BY - CRAIG BOOREY  
APPROVED BY - CRAIG BOOREY  
UNLESS OTHERWISE SPECIFIED DIMENSIONS ARE IN INCHES  
TOLERANCES ARE:  
DECIMALS .XX ± 0.3, .XXX  
± 0.0  
ANGLES ± 2°  
PROJECTION  
A

NOTES:  
CASE MUST BE GROUNDED  
WHEN PASSING WIRES THROUGH METAL HOLES A GROMMET MUST BE USED



REVISION HISTORY			
REV	ECN	DATE	DESCRIPTION
B	EDN-000-0008197	2/27/2015	REVISED LIGHTS
C	EDN-000-0014489	2/27/2015	REMOVED EXTRA LIGHTS
D	EDN-000-0016255	2/23/2028	NEW LIGHTS

REV	ECN	DATE	DESCRIPTION
B	EDN-000-0008197	2/27/2015	REVISED LIGHTS
C	EDN-000-0014489	2/27/2015	REMOVED EXTRA LIGHTS
D	EDN-000-0016255	2/23/2028	NEW LIGHTS

CIRCUIT #1	LOADING
120V	
150V	
180V	

REV	ECN	DATE	DESCRIPTION
B	EDN-000-0008197	2/27/2015	REVISED LIGHTS
C	EDN-000-0014489	2/27/2015	REMOVED EXTRA LIGHTS
D	EDN-000-0016255	2/23/2028	NEW LIGHTS

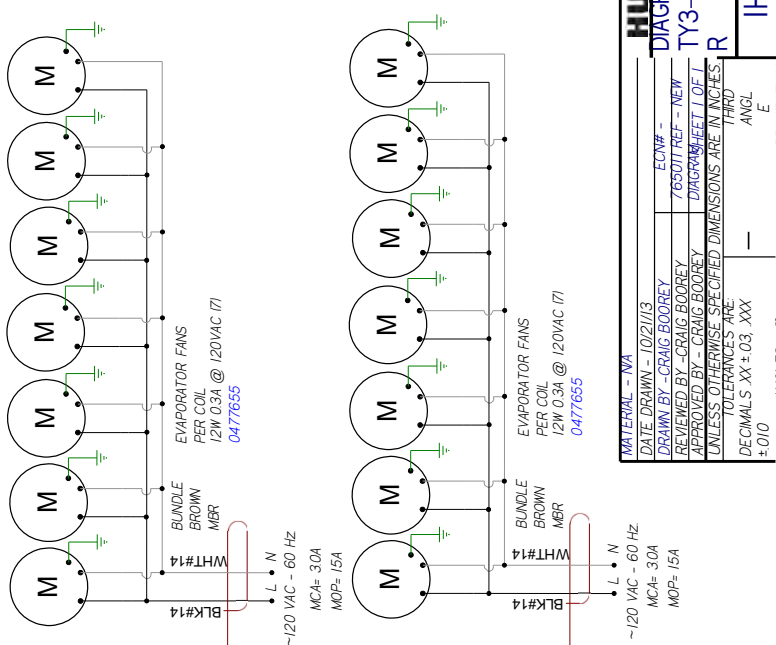
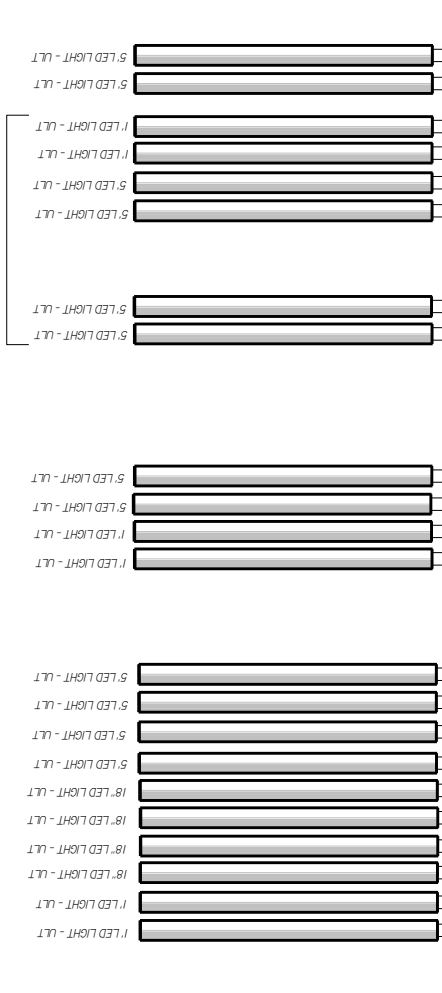
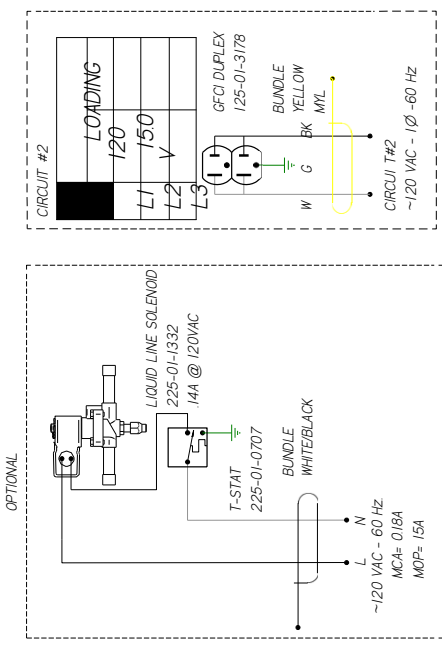

**HUSSMANN**  
**DIAGRAM-**  
**TY3-6X161-R**

MATERIAL - NA  
 DATE DRAWN - 10/21/13  
 DRAWN BY - CRAIG BOOREY  
 REVIEWED BY - CRAIG BOOREY  
 APPROVED BY - CRAIG BOOREY  
 UNLESS OTHERWISE SPECIFIED DIMENSIONS ARE IN INCHES  
 TOLERANCES ARE:  
 FRACTIONS .XX ± 0.0, .XXX ± 0.0  
 DECIMALS .XX ± 0.0, .XXX ± 0.0  
 ANGLES ± 2°  
 PROJECTION



NOTES:  
 CASE MUST BE GROUNDED

REVISION HISTORY		REV. BY	CHKD BY	APPR BY
REV	EN	DATE	DESCRIPTION	RELEASED TO PRODUCTION
1	A	20080403	LEDA-CAP-001087	
				CB
				CB
				CB

CIRCUIT #1	LOADING
	120V
	150V
	180V

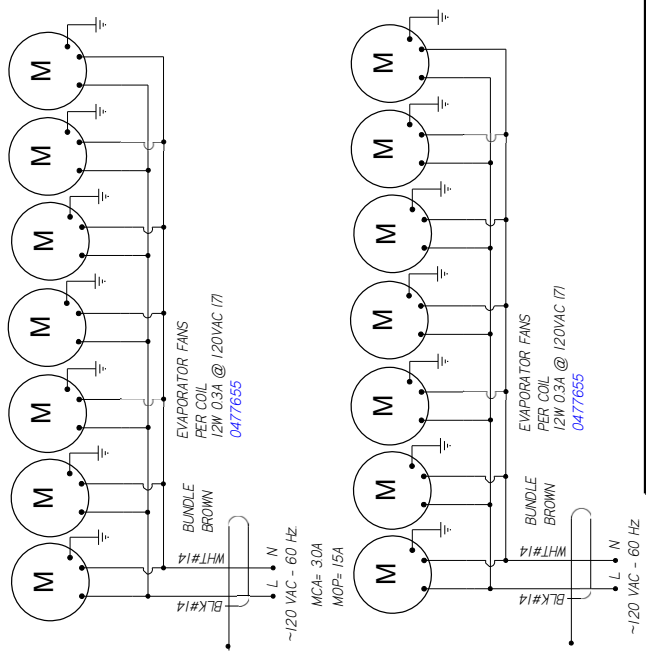
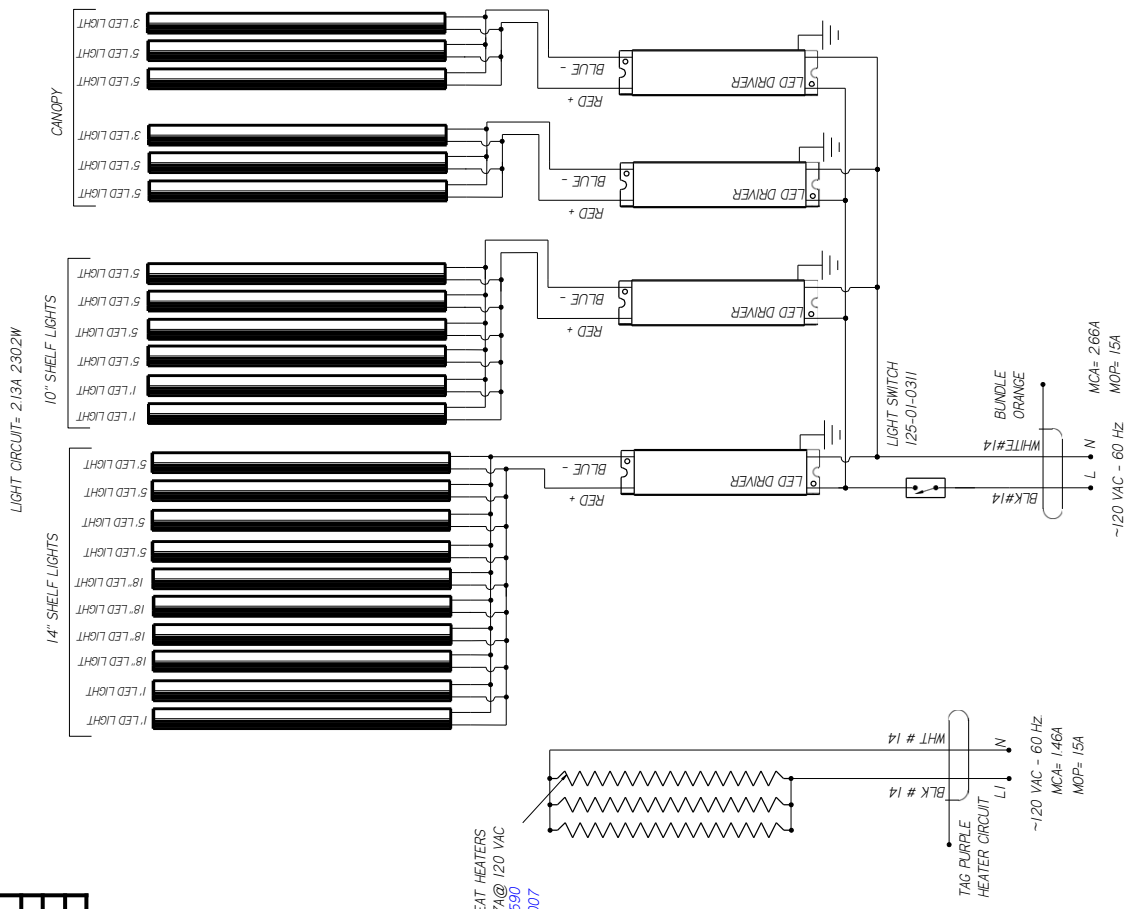
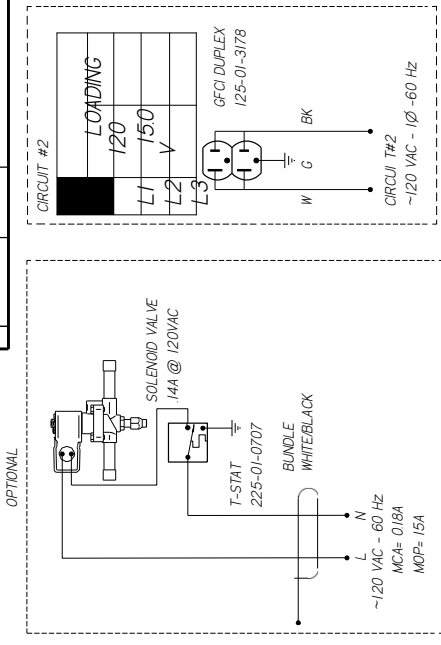

**HUSSMANN**  
**DIAGRAM**  
**TY3ECRC- 6X161-R**

MATERIAL - N/A  
DATE DRAWN - 4-3-18  
DRAWN BY - CRAIG BOOREY  
REVIEWED BY - CRAIG BOOREY  
UNLESS OTHERWISE SPECIFIED DIMENSIONS ARE IN INCHES  
TOLERANCES ARE:  
DECIMALS .XX ± 0.3 .XXX  
± 0.0  
ANGLES ± 2°  
PROJECTION

REF -  
SHEET OF  
ECON-CAP-0010917

3059427 | A

NOTES:  
CASE MUST BE GROUNDED  
WHEN PASSING WIRES THROUGH METAL HOLES A GROMMET MUST BE USED



CIRCUIT #1

LOADING	
120V	
150	
20	

LIGHT CIRCUIT  
53A 58.2W @ 120V

CANOPY LIGHTS

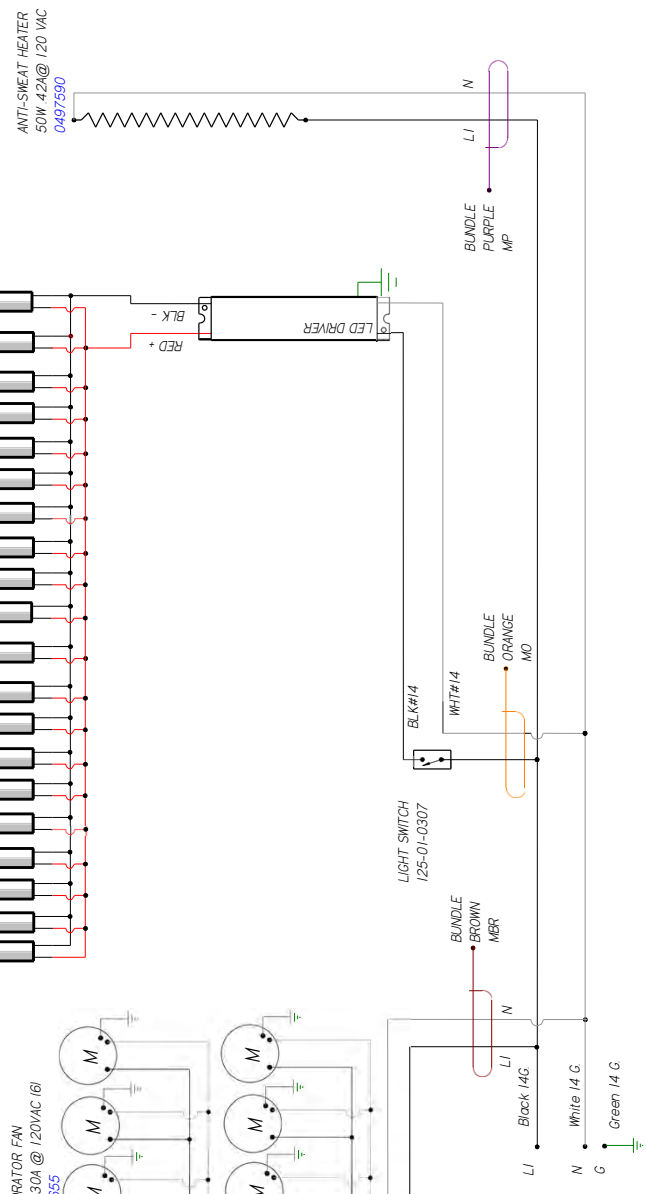
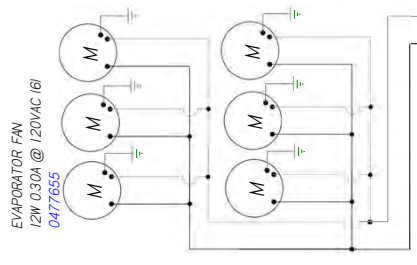
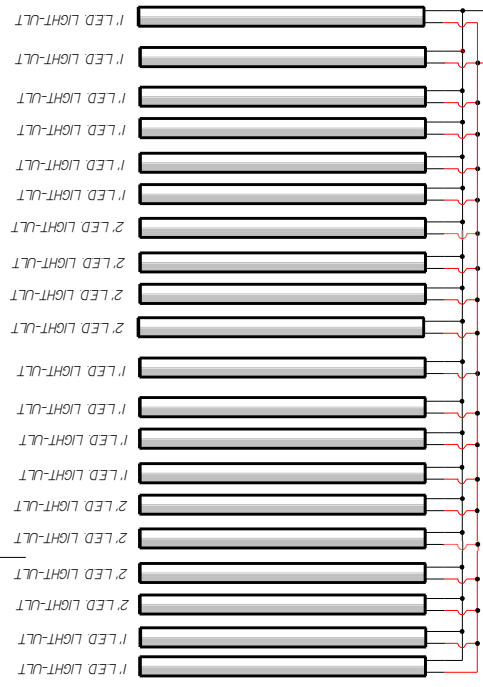

REVISION HISTORY		REV. BY	CHKD BY	APPR BY
A	ECN-CAP-0009957	2017/04/13	CB	CB
B	ECN-COD-0016286	2022/04/09	CB	CB

REVISION DESCRIPTION	
A	RELEASED TO PRODUCTION
B	NEW LIGHTS

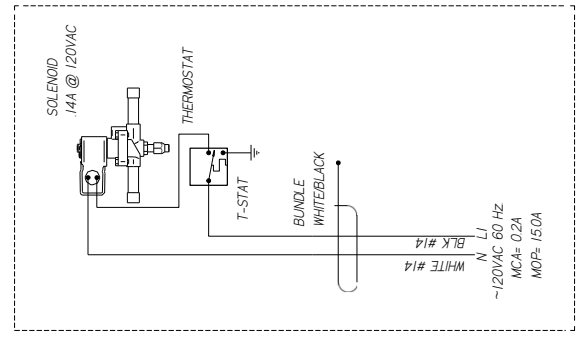
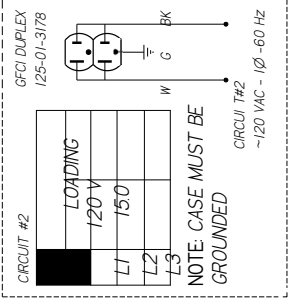

**HUSSMANN**  
**DIAGRAM-IY4-4X6I-R**  
 MATERIAL - NA  
 DATE DRAWN - 10-13-17  
 DRAWN BY - CRAIG BOOREY  
 REVIEWED BY - CRAIG BOOREY  
 APPROVED BY - CRAIG BOOREY  
 UNLESS OTHERWISE SPECIFIED DIMENSIONS ARE IN INCHES  
 TOLERANCES ARE:  
 DECIMALS .XX ±0.3 .XXX ±0.10  
 ANGLES ± 2°  
 PROJECTION  
 REF - ECN-CAP-0009957  
 SHEET NO. 1  
 SHEET LOE 1  
 DIMENSIONS ARE IN INCHES  
 THIRD ANGLE  
 E  
 B

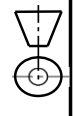

NOTES:  
 CASE MUST BE GROUNDED  
 WHEN PASSING WIRES THROUGH METAL HOLES A GROMMET MUST BE USED

CIRCUIT #1	INDG		
	120V		
	11	##	

REVISION HISTORY			
REV	EN	DATE	DESCRIPTION
A	ECN-CAP-0003235	2016/08/17	RELEASED TO PRODUCTION
B	ECN-COB-0015286	2022/04/20	NEW LIGHTS

LIGHT CIRCUIT  
128A 1352W @ 120V

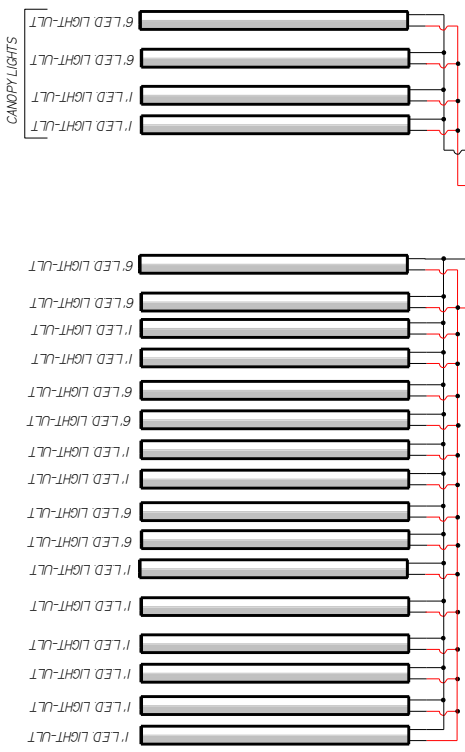

EMPIRATOR FAN  
12W @ 30A @ 120VAC (B)  
0477655

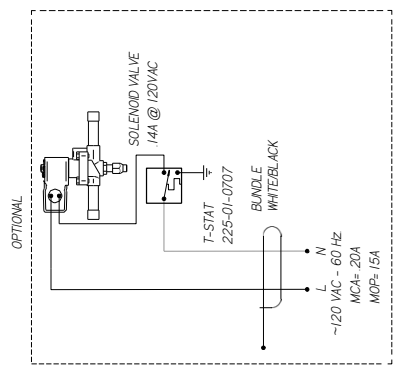
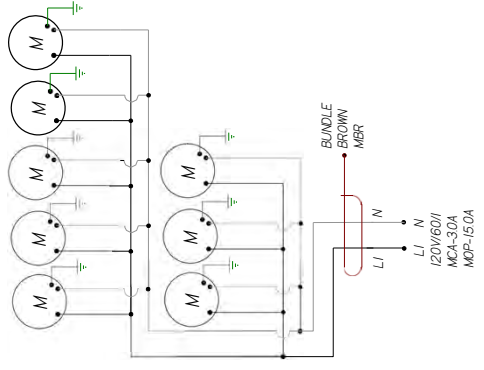

ANTI-SWEAT HEATER  
120 VAC  
III 0495007 40W, 33A  
III 0497590 50W, 42A

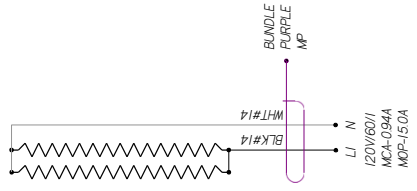

**HUSSMANN**  
DIAGRAM-1Y4-4X10I-R

MATERIAL - NA  
DATE DRAWN - 8-17-16  
DRAWN BY - CRAIG BOOREY  
REVIEWED BY - CRAIG BOOREY  
UNLESS OTHERWISE SPECIFIED DIMENSIONS ARE IN INCHES  
TOLERANCES ARE:  
DECIMALS .XX ± 0.3 .XXX ± 0.0  
ANGLES ± 2°

ECN-CAP-0003235  
REF -  
SHEET 1 OF 1  
THIRD ANGLE PROJECTION

3013474 | B

NOTES:  
CASE MUST BE GROUNDED  
WHEN PASSING WIRES THROUGH METAL HOLES A GROMMET MUST BE USED

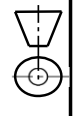

REV	ECN	DATE	REVISION DESCRIPTION	REV BY	CHKD BY	APPR BY
A	743531	2016/07/17	RELEASED TO PRODUCTION	CB	CB	CB
B	980241	2016/04/16	CHANGED ANTI-SWEAT HEATER	CB	CB	CB
C	EDC-CDD-005298	2022/04/20	NEW LIGHTS	CB	CB	CB

REVISION HISTORY
REVISED TO PRODUCTION
CHANGED ANTI-SWEAT HEATER
NEW LIGHTS

LOADING
120 V
L1 15.0
L2
L3

NOTE: CASE MUST BE GROUNDED

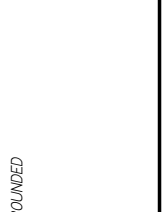
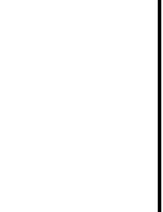
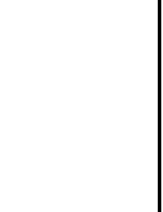
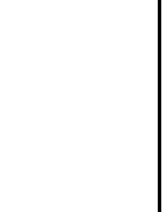
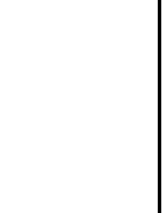
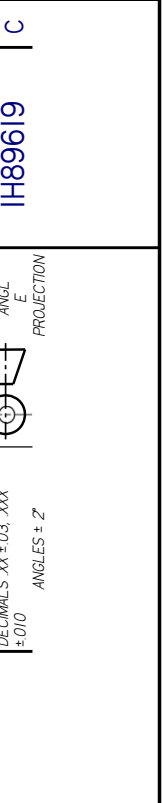
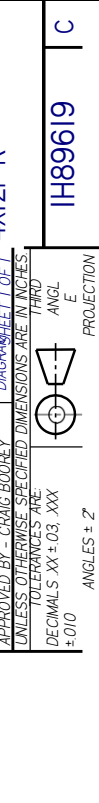
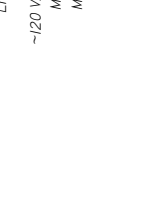
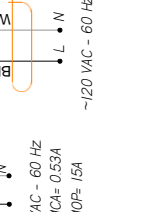
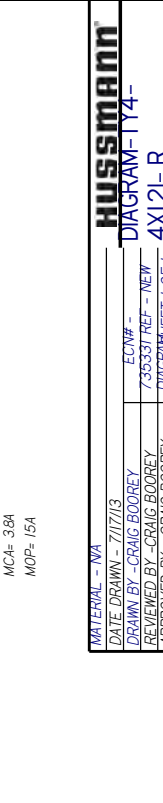
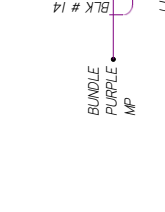
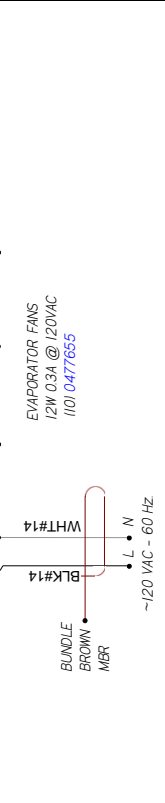
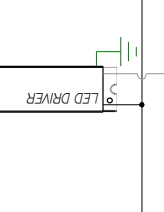
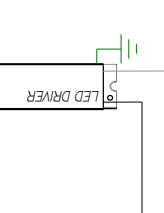
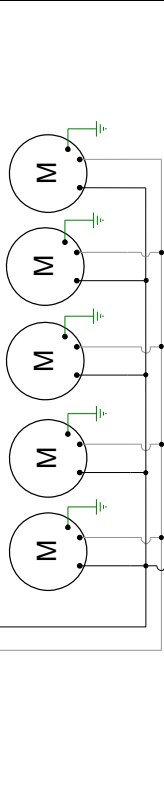
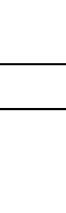
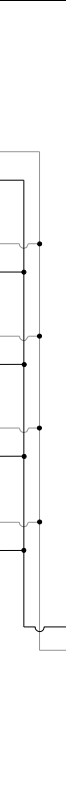
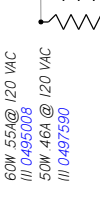
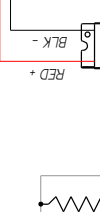
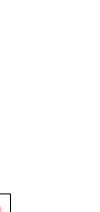
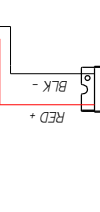
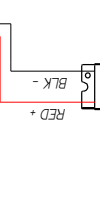
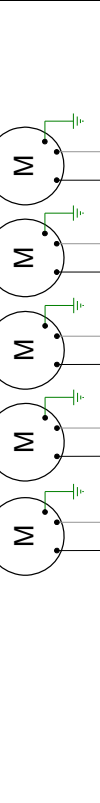
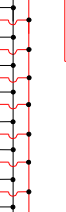
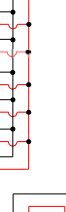
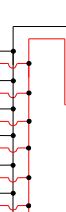
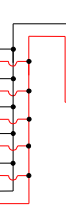
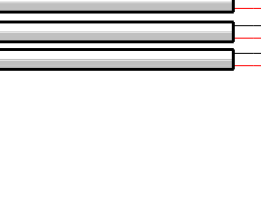
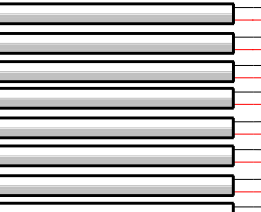
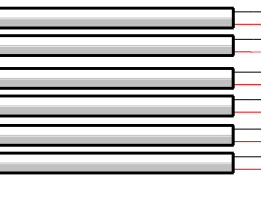
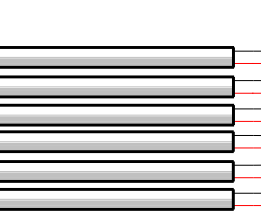
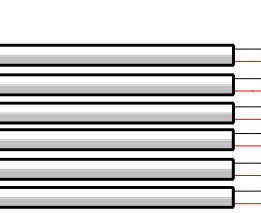
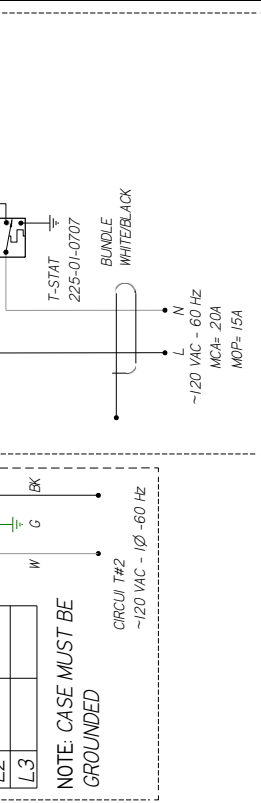
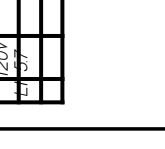
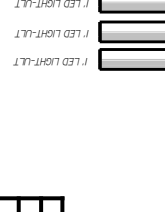
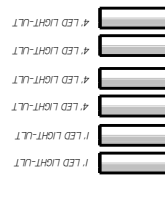
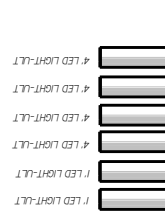
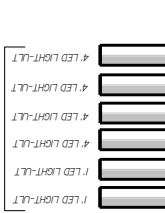
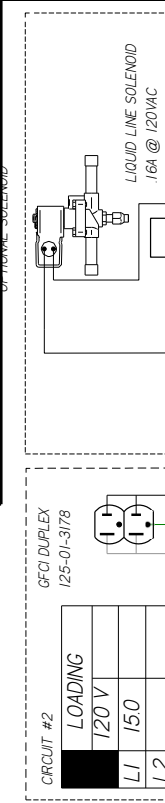

NOTES:  
CASE MUST BE GROUNDED

DECIMALS XX +0.0, XXX +0.0  
ANGLES ± 2°  
PROJECTION

UNLESS OTHERWISE SPECIFIED DIMENSIONS ARE IN INCHES  
TOLERANCES ARE:  
THIRD ANGLE  
PROJECTION

APPROVED BY - CRAIG BOOREY  
DIAGRAM SHEET LOE  
7.35331 REF - NEW  
ECN# -

DRAWN BY - CRAIG BOOREY  
DATE DRAWN - 7/17/13

MATERIAL - N/A  
HUS5MANN

DIAGRAM-1Y4-  
4X12I-R

IH89619 | C



REVISION HISTORY			
REV	ECN	DATE	REVISION DESCRIPTION
A	ECN-000-0012732	2-25-21	RELEASED TO PRODUCTION
			REV BY/CHKD BY APPR BY
			CB CB CB

CIRCUIT #1	LOADING
120V	
150	
L1	
L2	
L3	

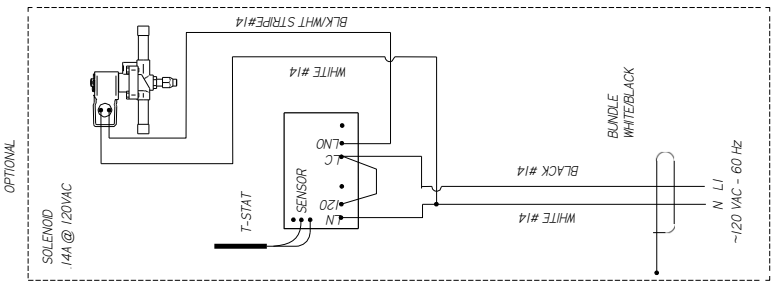
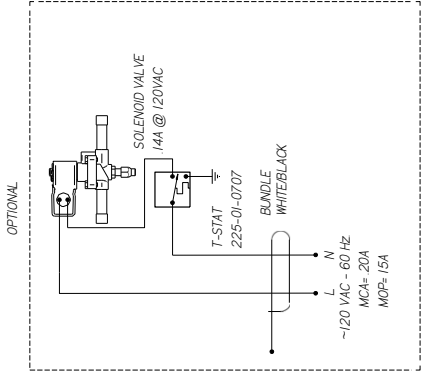
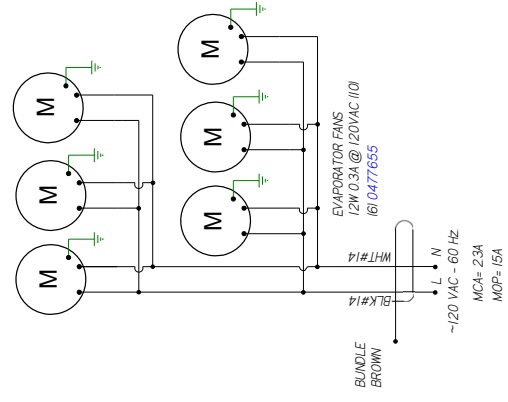
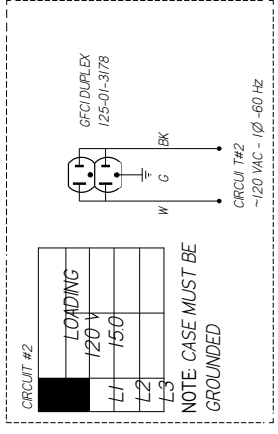
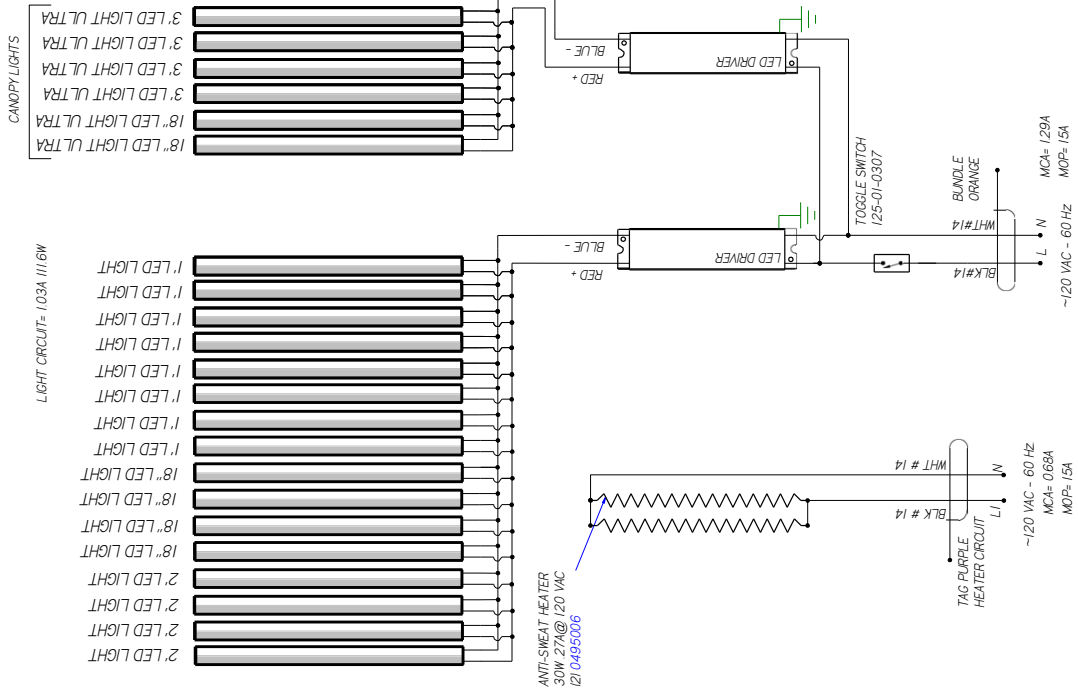

**HUSSMANN**

**DIAGRAM-**  
**TY4ECRC- 5X7I-R**

**UL COLOR CODES / ABBREVIATIONS**

- RED = RD
- BLACK = BK
- BLUE = BL
- YELLOW = YL
- GRAY = GR
- WHITE = WT
- GREEN = GN
- BROWN = BN
- ORANGE = OR
- OR VIOLET = VT

**FACTORY 146A WIRE**  
-FACTORY 106A WIRE  
-FIELD WIRE

**DO NOT SCALE DRAWING**  
SHEET 1 OF 1

**3144548**

**A**

- NOTES:**
1. PRINTED DOCUMENT REQUIRED SETTING. ALL COLORS BLACK & WHITE
  2. CASE & ANY REMOVABLE PANEL WITH ELECTRICAL PARTS MUST BE GROUNDED.
  3. WHEN PASSING WIRES THROUGH METAL HOLES A GROMMET MUST BE USED

REVISION HISTORY		DATE	REV. BY	CHKD BY	APPR BY
1.	ECN-CAP-004942	2018/01/28			
			CB	CB	CB
			CB	CB	CB

CIRCUIT #1	LOADING
120V	
L1	
L2	
L3	

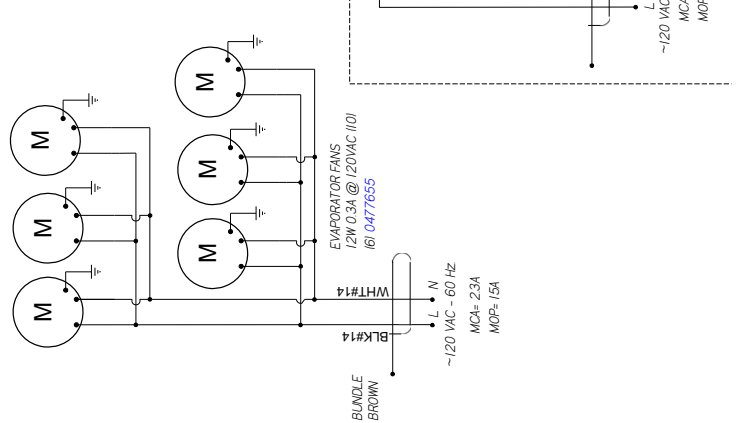
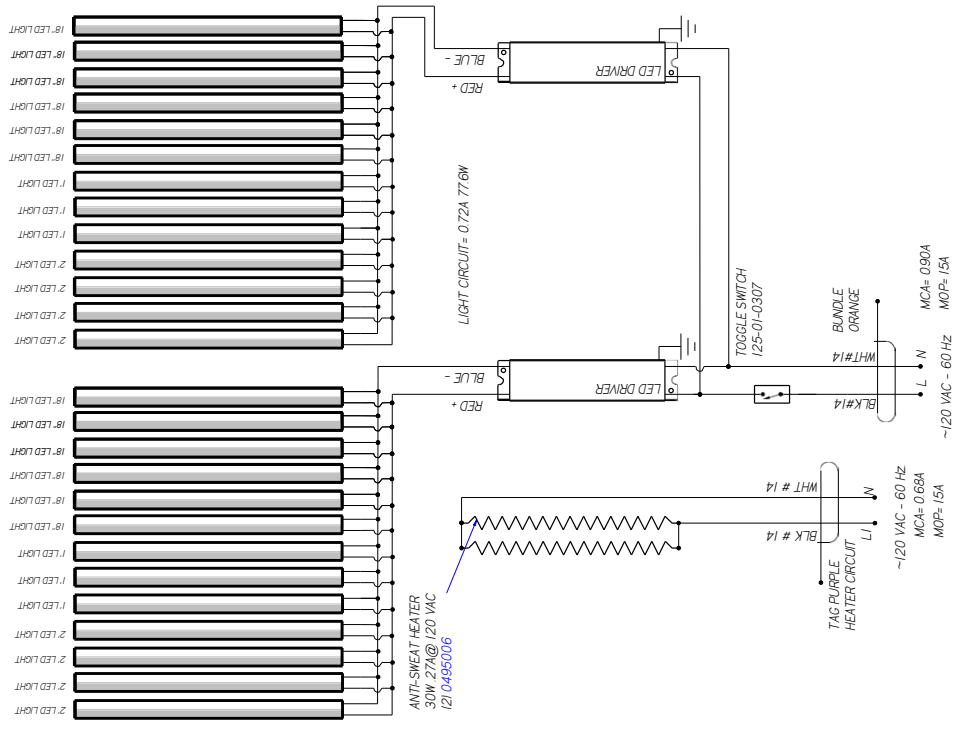
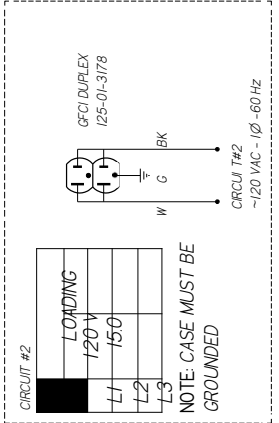

**HUSSMANN**  
DIAGRAM-IY4EC-5X7 I-R

MATERIAL - NA

DATE DRAWN - 10-26-18

DRAWN BY - CRAIG BOOREY

REVIEWED BY - CRAIG BOOREY

APPROVED BY - CRAIG BOOREY

UNLESS OTHERWISE SPECIFIED DIMENSIONS ARE IN INCHES

TOLERANCES ARE:

THIRD ANGLE PROJECTION

DECIMALS .XX ± 0.3 .XXX ± 0.0

ANGLES ± 2°

ECN-CAP-007494Z

REF - SHEET 1 OF 3

3078669 | A

NOTES:  
CASE MUST BE GROUNDED  
WHEN PASSING WIRES THROUGH METAL HOLES A GROMMET MUST BE USED

REV	EN	DATE	REVISION DESCRIPTION	REV BY	CHKD BY	APPR BY
A	983529	2016/08/03	RELEASED TO PRODUCTION	CB	CB	CB
B	ECN-CDD-006286	2022/04/27	NEW LIGHTS	CB	CB	CB
C	ECN-CDD-007638	2023/02/09	REVISED SOLENOID WIRING	CB	CB	CB

CIRCUIT #2	LOADING
	120 V
L1	150
L2	
L3	

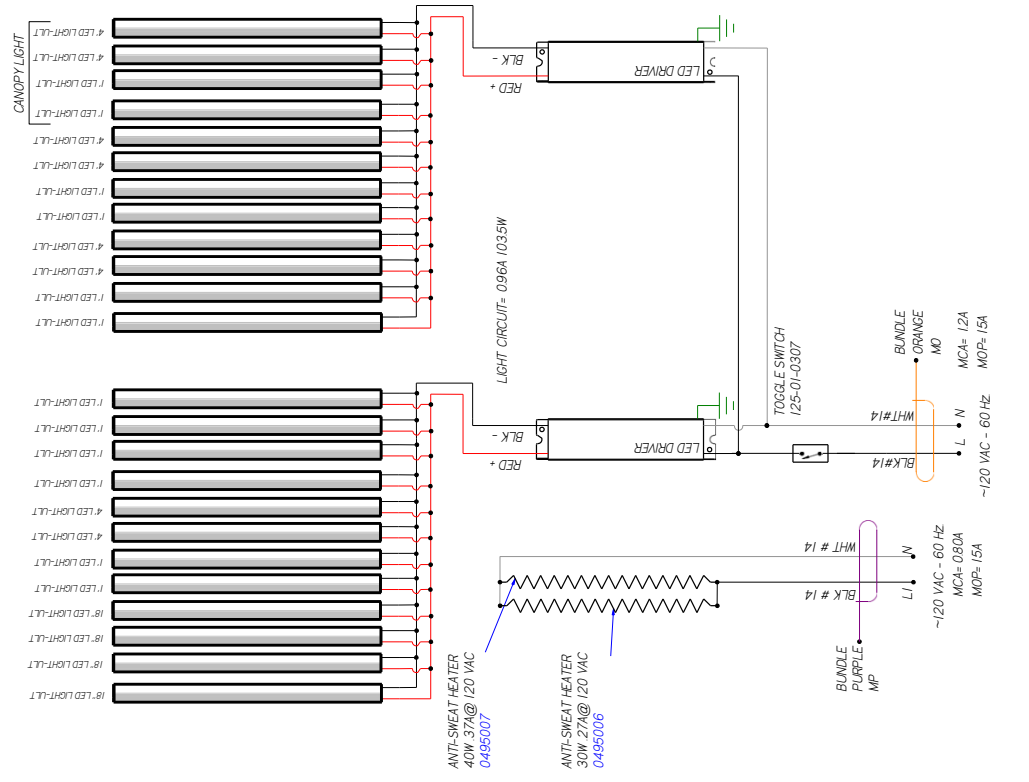
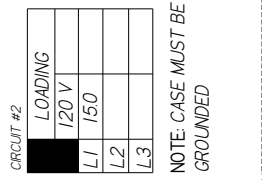

CIRCUIT #1	LOADING
	120V
	150

**HUSSMANN**  
DIAGRAM-IY4-5X91-R

MATERIAL - NA  
DATE DRAWN - 6-3-15  
DRAWN BY - CRAIG ROOREY  
REVIEWED BY - CRAIG ROOREY  
ECON# - 983529  
REF -  
SHEET LOF  
UNLESS OTHERWISE SPECIFIED DIMENSIONS ARE IN INCHES  
TOLERANCES ARE:  
THIRD ANGL  
E  
PROJECTION  
DECIMALS .XX ±0.3 .XXX ±0.0  
ANGLES ± 2°

NOTES:  
CASE MUST BE GROUNDED

REVISION HISTORY					
REV	ECN	DATE	REV BY	CHKD BY	APPR BY
A	765011	2023/09/24			
B	ECN-CDD-0015287	2022/04/25			
NEW DIAGRAM			CB	CB	CB
NEW LIGHTS			CB	CB	CB

CIRCUIT #1	LOADING
	120V
	L1
	L2
	L3

LIGHT CIRCUIT= 1.36A /466W

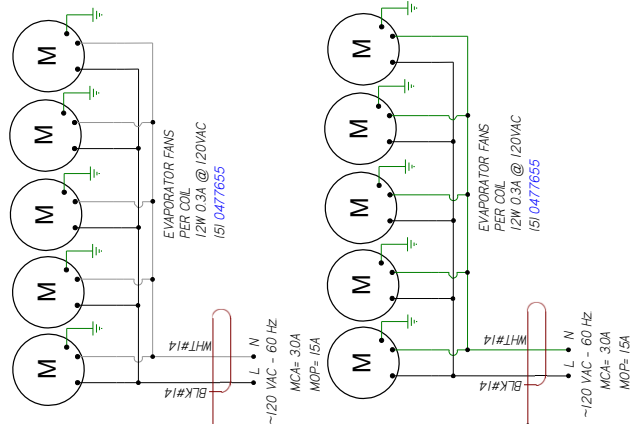
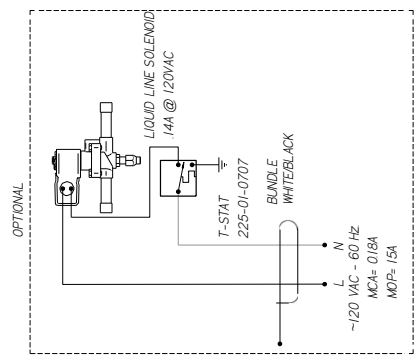
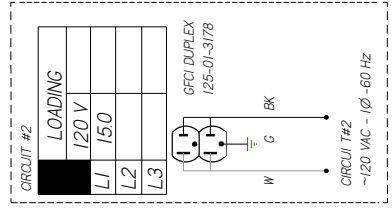
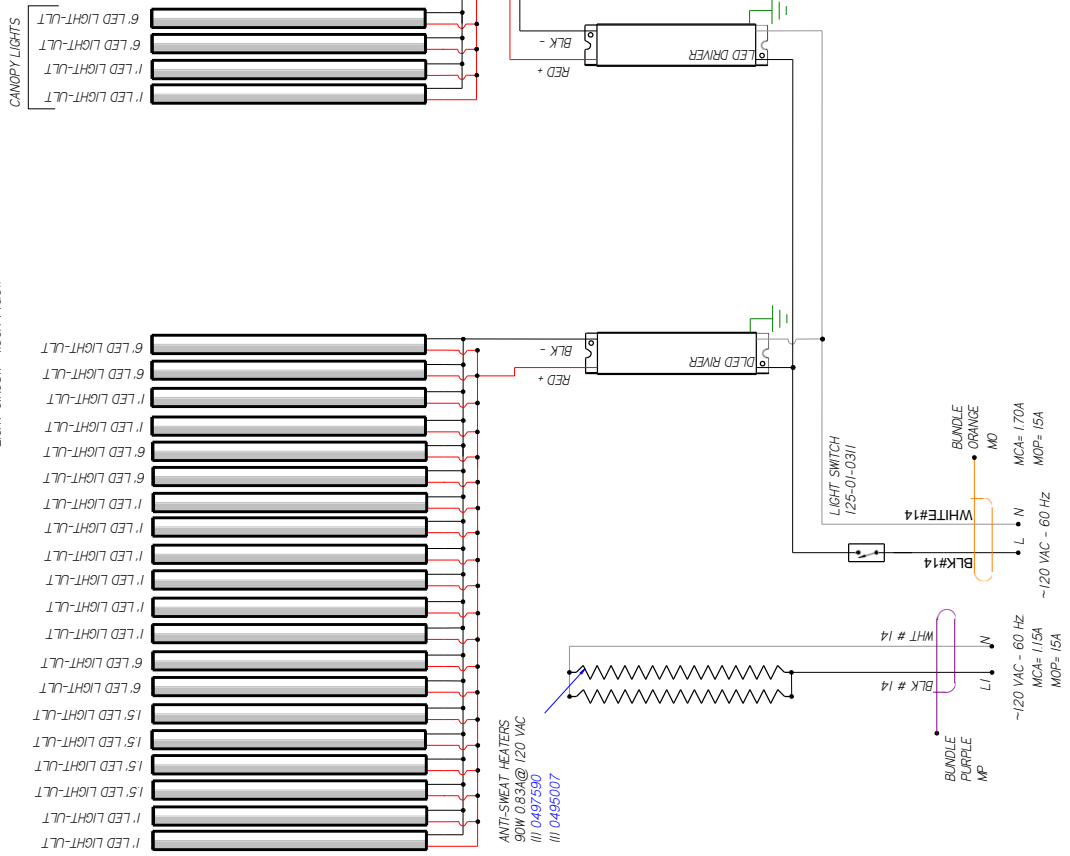

**HUSSMANN**  
DIAGRAM-  
TY4-5X11-  
R

MATERIAL - NA  
DATE DRAWN - 9/24/13  
DRAWN BY - CRAIG BOOREY  
REVIEWED BY - CRAIG BOOREY  
APPROVED BY - CRAIG BOOREY

ECN# - 765011 REF - NEW  
DIAGRAM SHEET NO. T  
UNLESS OTHERWISE SPECIFIED DIMENSIONS ARE IN INCHES  
TOLERANCES ARE:  
THIRD ANGL  
E  
PROJECTION

DECIMALS .XX ± 0.3, .XXX ± 0.10  
ANGLES ± 2°

NOTES:  
CASE MUST BE GROUNDED

CIRCUIT #

REV	DATE	DESCRIPTION	REV BY	CHKD BY	APPR BY
B	2-23-21	ADDED 3RD LED DRIVER	CB	CB	CB
C	3-29	REVISED LIGHT LAYOUT	CB	CB	CB

REV	DATE	DESCRIPTION	REV BY	CHKD BY	APPR BY
B	2-23-21	ADDED 3RD LED DRIVER	CB	CB	CB
C	3-29	REVISED LIGHT LAYOUT	CB	CB	CB

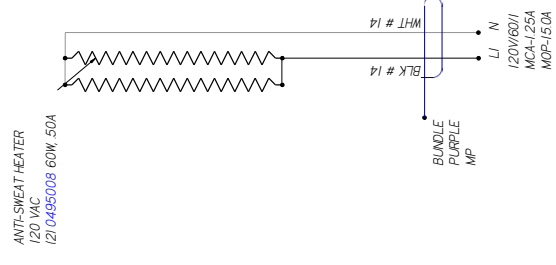
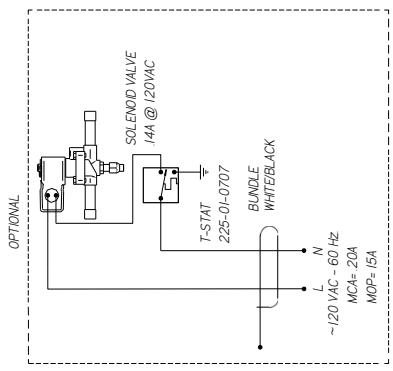
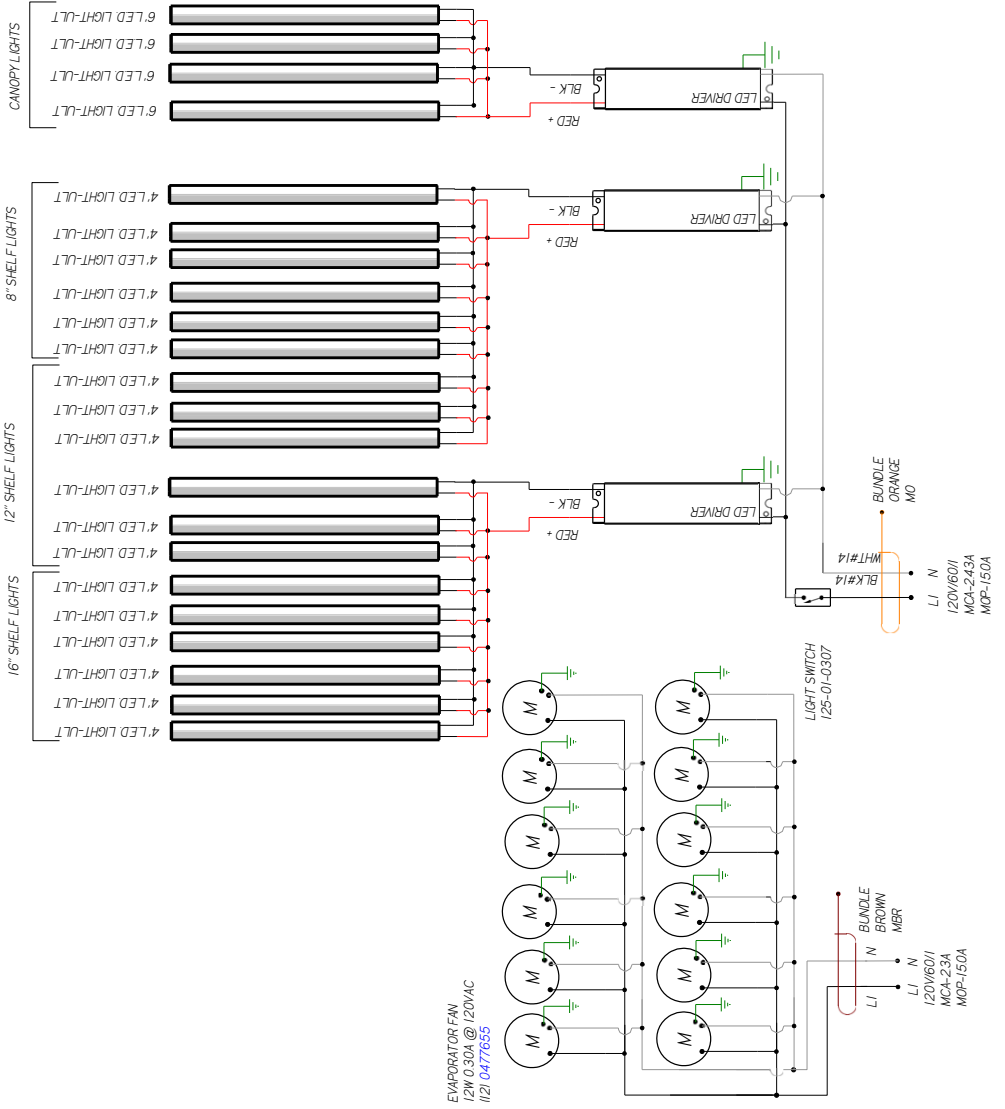

**HUSSMANN**  
DIAGRAM-TY4-5X12C  
-R

UL COLOR CODES / ABBREVIATIONS

- RED = RD
- BLACK = BK
- BLUE = BL
- YELLOW = YL
- GRAY = GR
- WHITE = WT
- GREEN = GN
- BROWN = BN
- ORANGE = OR
- OR VIOLET = OV

FACTORY 14GA WIRE  
-FACTORY 10GA WIRE  
-FIELD WIRE  
-DO NOT SCALE DRAWING  
SHEET 1 OF 1

3142085

- NOTES:**
1. PRINTED DOCUMENT REQUIRED SETTING. ALL COLORS BLACK & WHITE
  2. CASE & ANY REMOVABLE PANEL WITH ELECTRICAL PARTS MUST BE GROUNDED.
  3. WHEN PASSING WIRES THROUGH METAL HOLES A GROMMET MUST BE USED

REVISION HISTORY			
REV#	ECN	DATE	DESCRIPTION
A	01/06/03	20/05/2015	RELEASED FOR PRODUCTION
B	ECN-000-004489	20/10/01/15	REMOVED LED LIGHTS
C	ECN-000-0016287	20/22/04/25	NEW LED LIGHTS

CIRCUIT #1	
LOADING	
120V	
L1	150
L2	
L3	

CIRCUIT #2	
LOADING	
120V	
L1	150
L2	
L3	

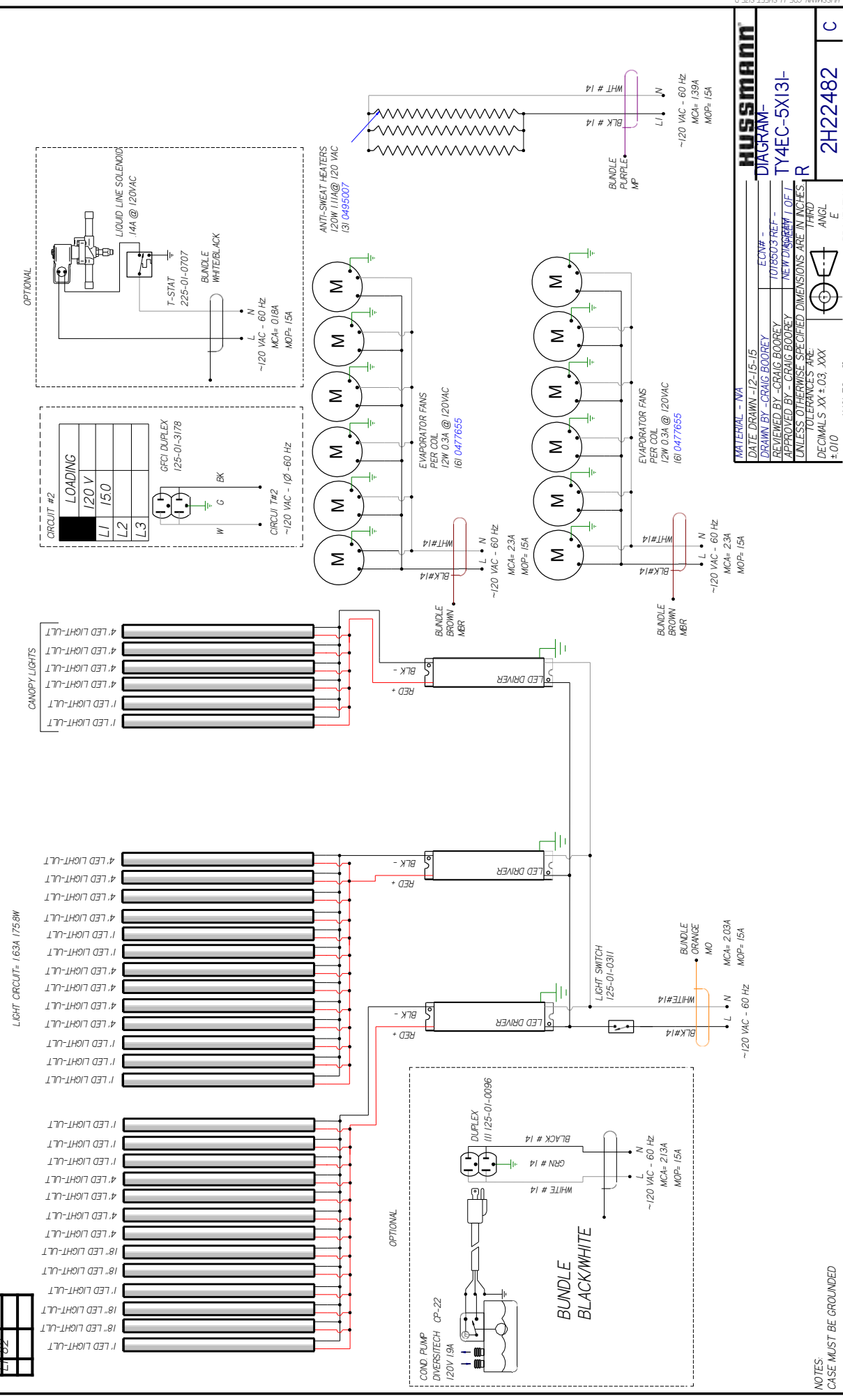

**MATERIAL - NA**  
 DATE DRAWN - 12-15-15  
 DRAWN BY - CRAIG BOOREY  
 REVIEWED BY - CRAIG BOOREY  
 APPROVED BY - CRAIG BOOREY  
 UNLESS OTHERWISE SPECIFIED DIMENSIONS ARE IN INCHES  
 TOLERANCES ARE:  
 FRACTIONS XX ± 0.3, XXX ± 0.10  
 DECIMALS XX ± 0.3, XXX ± 0.10  
 ANGLES ± 2°  
 PROJECTION  
 ANGLE  
 E

**HUSSMANN**  
**DIAGRAM-**  
**TY4EC-5X13-I**  
**R**

ECNR -  
 1018503 REF -  
 NEW DIAGRAM TO E  
 DIMENSIONS ARE IN INCHES  
 TOLERANCES ARE:  
 FRACTIONS XX ± 0.3, XXX ± 0.10  
 DECIMALS XX ± 0.3, XXX ± 0.10  
 ANGLES ± 2°  
 PROJECTION  
 ANGLE  
 E

2H22482 | C

NOTES:  
 CASE MUST BE GROUNDED



REV	EN	DATE	REVISION HISTORY	REV BY	CHK BY	APP BY
A	ECN-CAP-001913	20080313	RELEASED TO PRODUCTION	CB	CB	CB
B	ECN-COD-001343	20200914	ADDED DRIVER FOR LEAD CANOPY LIGHTS	CB	CB	CB
C	ECN-COD-0015281	20220427	NEW LIGHTS	CB	CB	CB

LOADING	120 V	150	180
L1			
L2			
L3			

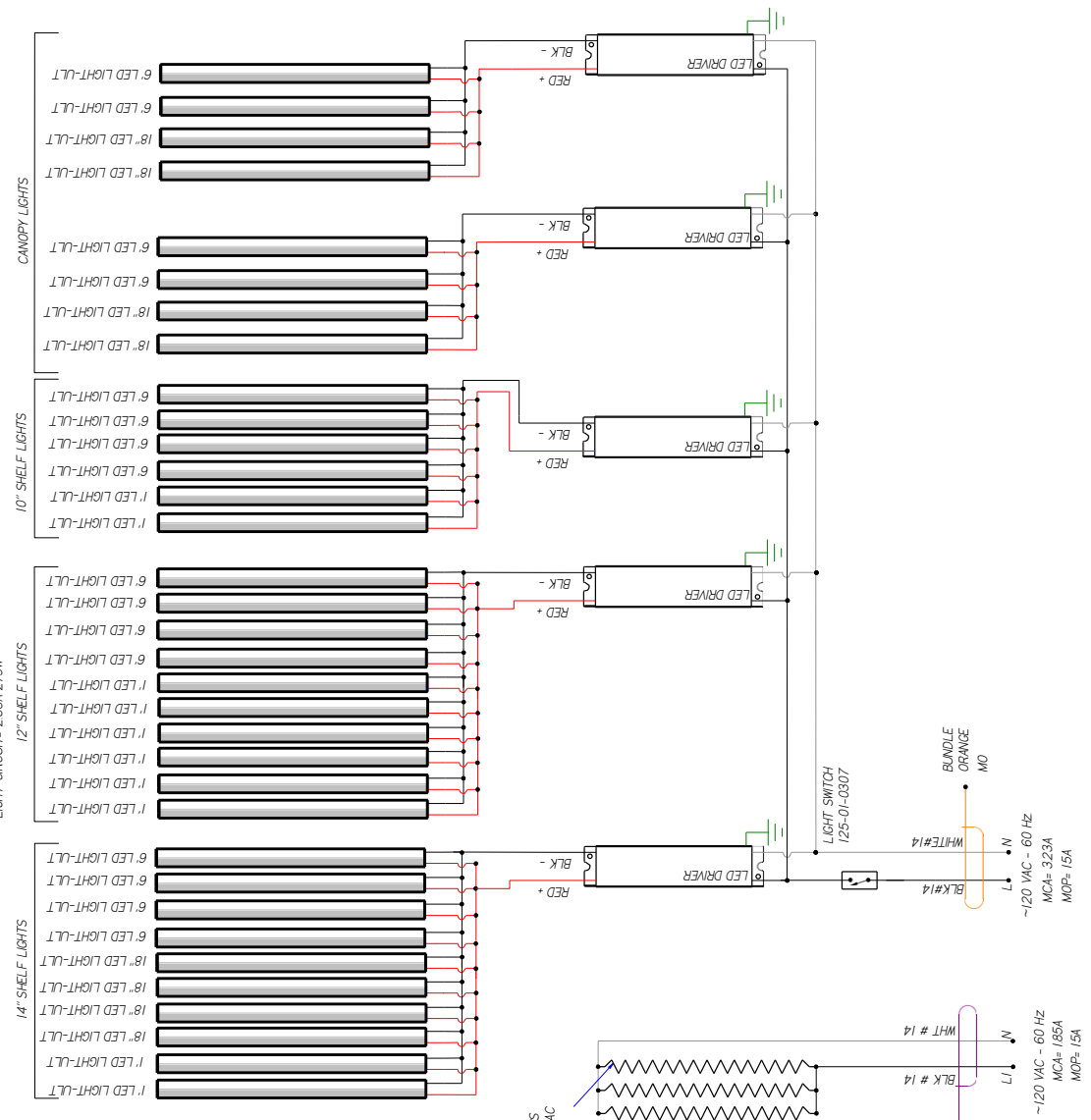
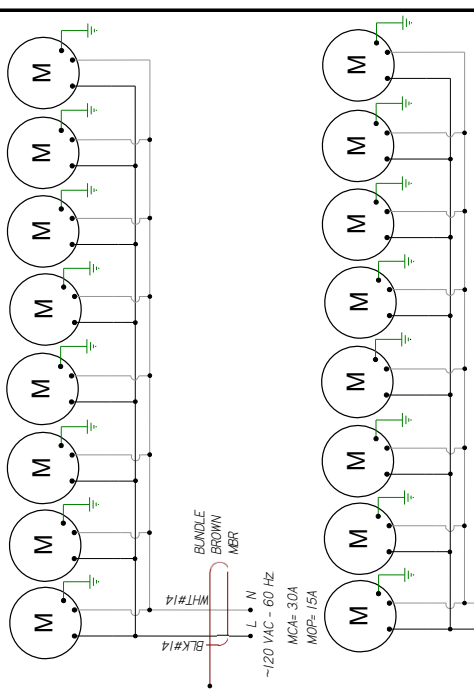
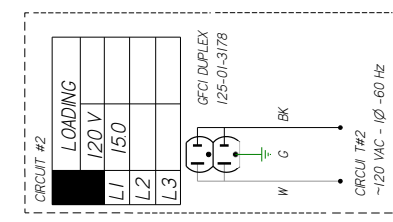
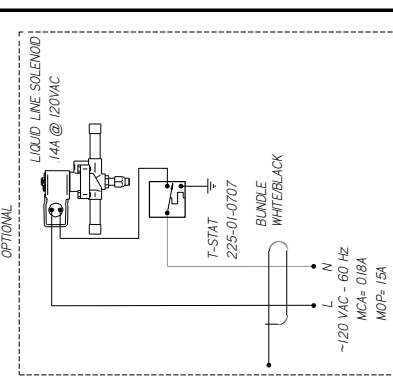

CIRCUIT #1	LOADING	120 V	150	180

ANTI-SWEAT HEATERS	160W 148A @ 120 VAC	III 0495007	121 0495008

MATERIAL - IVA  
 DATE DRAWN - 3-13-18  
 DRAWN BY - CRAIG BOOREY  
 REVIEWED BY - CRAIG BOOREY  
 APPROVED BY - CRAIG BOOREY  
 SHEET NO. 1  
 UNLESS OTHERWISE SPECIFIED DIMENSIONS ARE IN INCHES  
 TOLERANCES ARE:  
 FRACTIONS .XX ± 0.3 .XXX  
 DECIMALS .XX ± 0.3 .XXX  
 ANGLES ± 2'  
 PROJECTION

HUSSMANN  
 DIAGRAM-1Y4EC-  
 5XI 71-R

3058176 | C

NOTES:  
 CASE MUST BE GROUNDED  
 WHEN PASSING WIRES THROUGH METAL HOLES A GROMMET MUST BE USED



CIRCUIT #1	LOADING	120V	150V	180V

REVISION HISTORY		REV	DATE	DESCRIPTION	APP'D BY	CHK'D BY	DATE
A	765011	2019/09/24	NEW DIAGRAM				CB
B	LEGN-000-2018Z88	2022/04/27	NEW LIGHTS				CB

LIGHT CIRCUIT= 2024, 2182W

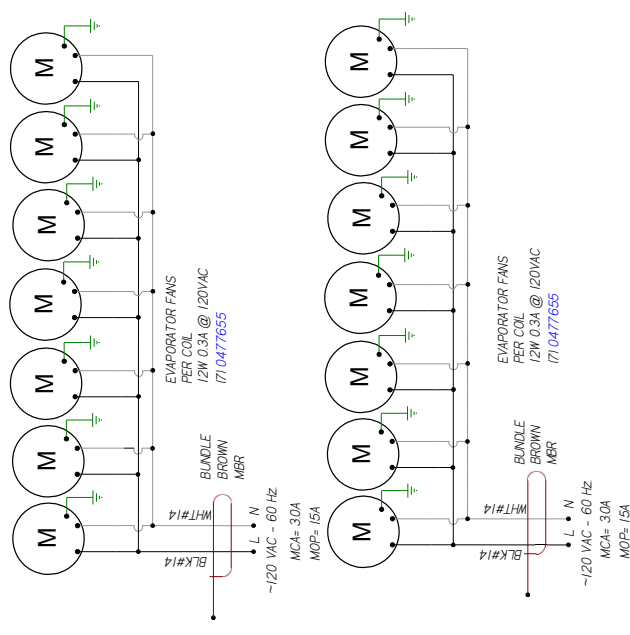
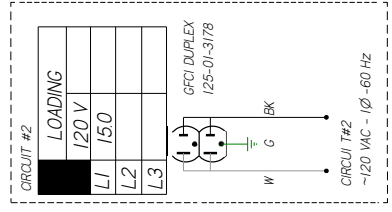
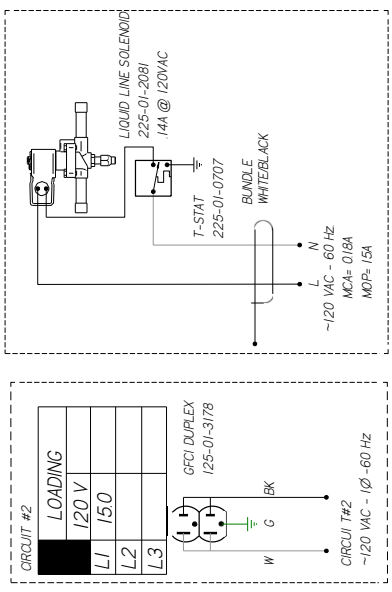
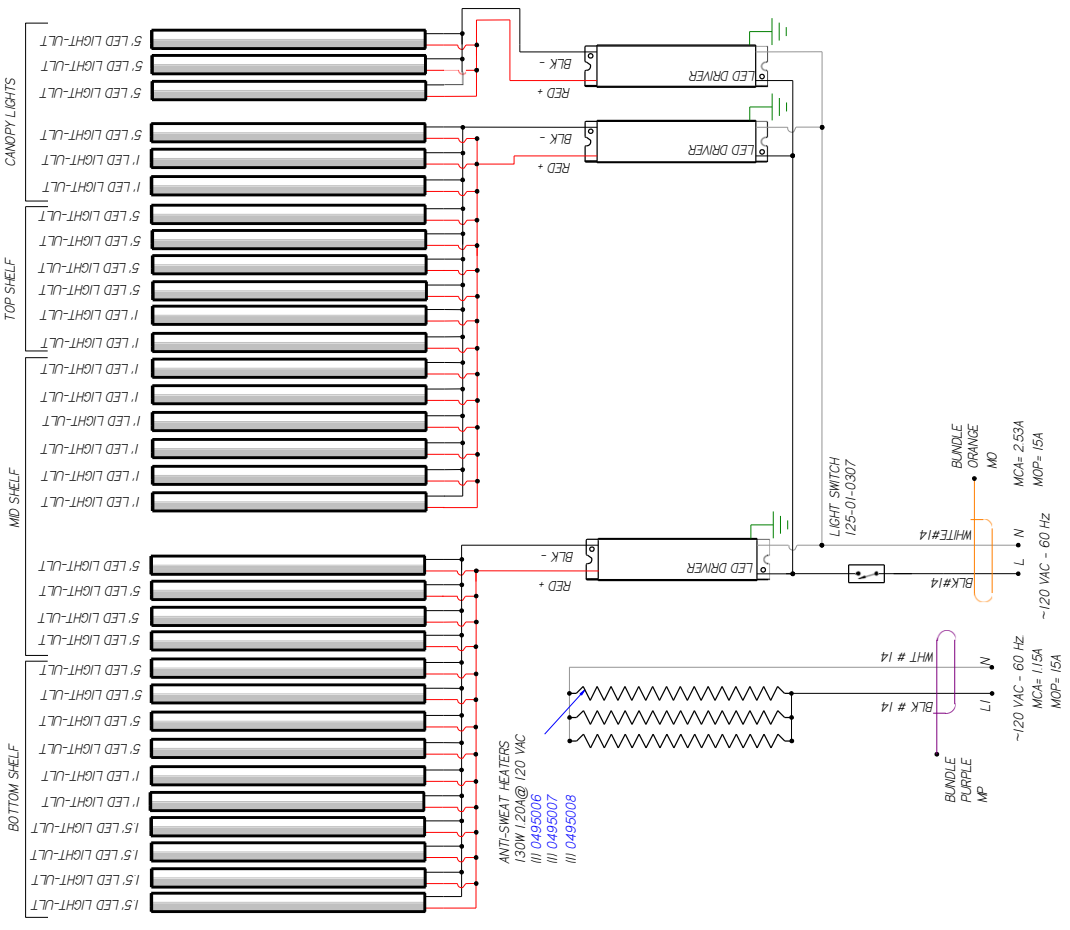

**MATERIAL - NA**  
 DATE DRAWN - 9/24/13  
 DRAWN BY - CRAIG BOOREY  
 REVIEWED BY - CRAIG BOOREY  
 APPROVED BY - CRAIG BOOREY  
 UNLESS OTHERWISE SPECIFIED DIMENSIONS ARE IN INCHES  
 TOLERANCES ARE:  
 DECIMALS .XX ± 0.3 .XXX  
 ANGLES ± 2°  
 PROJECTION

**HUSSMANN**  
 DIAGRAM -  
 TY4-5X151-  
 R  
 IH92380 | B

NOTES:  
 CASE MUST BE GROUNDED

REVISION HISTORY						
REV	EN	DATE	DESCRIPTION	REV BY	CHK BY	APPR BY
A	ECN-CAP-0002200	2016/08/03	RELEASED TO PRODUCTION	CB	CB	CB
B	ECN-COD-004489	2020/09/04	ADDED DRIVER & ULTRALIGHTS	CB	CB	CB
C	ECN-COD-005282	2022/04/28	NEW LIGHTS	CB	CB	CB

CIRCUIT #2	LOADING
L1	150
L2	
L3	



ANTI-SWEAT HEATERS  
150W 1.39A @ 120 VAC  
III 0497590  
III 0495007  
III 0495008

LIGHT SWITCH  
125-01-0307  
BUNDLE ORANGE  
WHT #14

LED DRIVER  
RED +  
BLK -

EVAPORATOR FANS  
PER COIL  
12W 0.3A @ 120VAC  
I161 0477655  
BUNDLE BROWN  
WHT #14

MOTOR (M)  
BLK #14  
WHT #14

MOTOR (M)  
BLK #14  
WHT #14

MOTOR (M)  
BLK #14  
WHT #14

MOTOR (M)  
BLK #14  
WHT #14

MOTOR (M)  
BLK #14  
WHT #14

MOTOR (M)  
BLK #14  
WHT #14

MOTOR (M)  
BLK #14  
WHT #14

MOTOR (M)  
BLK #14  
WHT #14

MOTOR (M)  
BLK #14  
WHT #14

MOTOR (M)  
BLK #14  
WHT #14

MOTOR (M)  
BLK #14  
WHT #14

MOTOR (M)  
BLK #14  
WHT #14

MOTOR (M)  
BLK #14  
WHT #14

MOTOR (M)  
BLK #14  
WHT #14

CANOPY LIGHTS  
6 LED LIGHT ULT  
6 LED LIGHT ULT  
6 LED LIGHT ULT  
6 LED LIGHT ULT  
6 LED LIGHT ULT  
6 LED LIGHT ULT  
6 LED LIGHT ULT  
6 LED LIGHT ULT  
6 LED LIGHT ULT  
6 LED LIGHT ULT

TOP SHELF  
6 LED LIGHT ULT  
6 LED LIGHT ULT  
6 LED LIGHT ULT  
6 LED LIGHT ULT  
6 LED LIGHT ULT  
6 LED LIGHT ULT  
6 LED LIGHT ULT  
6 LED LIGHT ULT  
6 LED LIGHT ULT  
6 LED LIGHT ULT

MID SHELF  
6 LED LIGHT ULT  
6 LED LIGHT ULT  
6 LED LIGHT ULT  
6 LED LIGHT ULT  
6 LED LIGHT ULT  
6 LED LIGHT ULT  
6 LED LIGHT ULT  
6 LED LIGHT ULT  
6 LED LIGHT ULT  
6 LED LIGHT ULT

BOTTOM SHELF  
6 LED LIGHT ULT  
6 LED LIGHT ULT  
6 LED LIGHT ULT  
6 LED LIGHT ULT  
6 LED LIGHT ULT  
6 LED LIGHT ULT  
6 LED LIGHT ULT  
6 LED LIGHT ULT  
6 LED LIGHT ULT  
6 LED LIGHT ULT

OPTIONAL  
LIQUID LINE SOLENOID  
144 @ 120VAC  
T-STAT 225-01-0707  
BUNDLE WHITE/BLACK  
-120 VAC - 60 Hz  
MCA= 018A  
MOP= 15A

GFCI DUPLEX  
125-01-3178  
W G BK  
CIRCUIT #2  
-120 VAC - 60 Hz

MATERIAL - NA  
DATE DRAWN - 6-3-16  
DRAWN BY - CRAIG ROOREY  
REVIEWED BY - CRAIG ROOREY  
APPROVED BY - CRAIG ROOREY  
UNLESS OTHERWISE SPECIFIED DIMENSIONS ARE IN INCHES  
TOLERANCES ARE:  
DECIMALS .XX ±0.3 .XXX  
±0.0 ANGLES ± 2°  
PROJECTION

NOTES:  
CASE MUST BE GROUNDED  
WHEN PASSING WIRES THROUGH METAL HOLES A GROMMET MUST BE USED

HUSSMANN  
DIAGRAM-IY4-  
5X171-R

3008164 | C

REVISION HISTORY			
REV	ECN	DATE	BY
B	ECN-000-0016298	2022/04/28	CB
REVISION DESCRIPTION: NEW LOGOS			
CHG BY		CHK BY	APPR BY
CB		CB	CB

CIRCUIT #1	LOADING
L1	120V
L2	150V
L3	

LIGHT CIRCUIT= 133A 144W

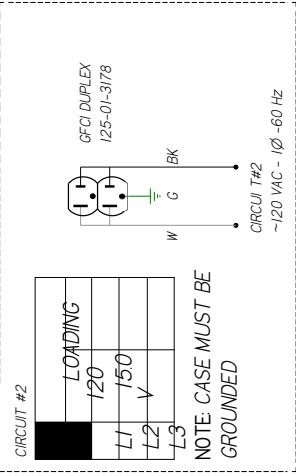
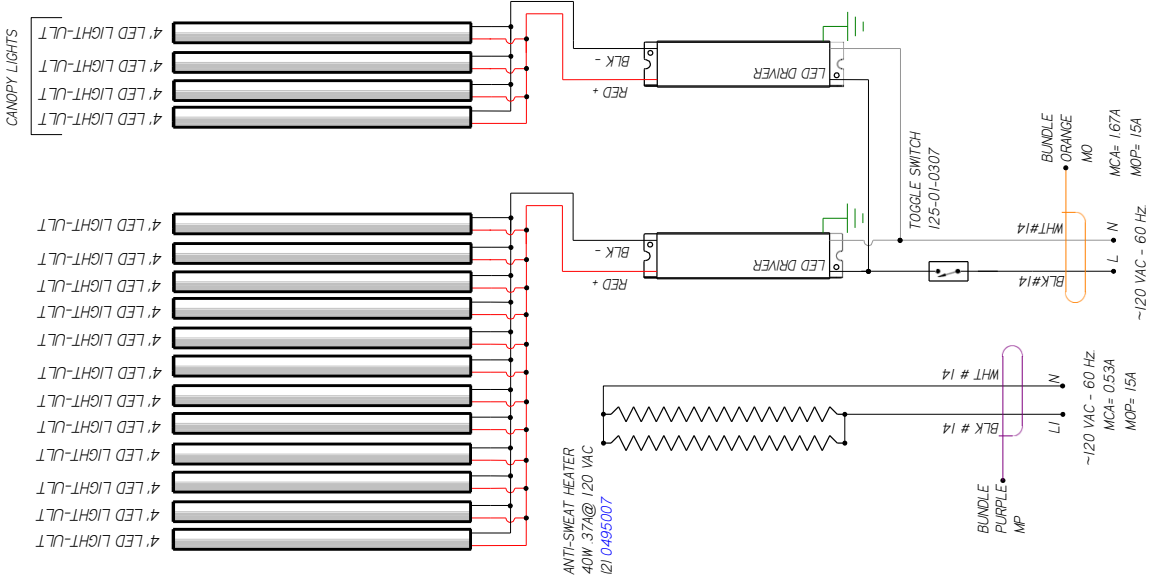

NOTE: CASE MUST BE GROUNDED

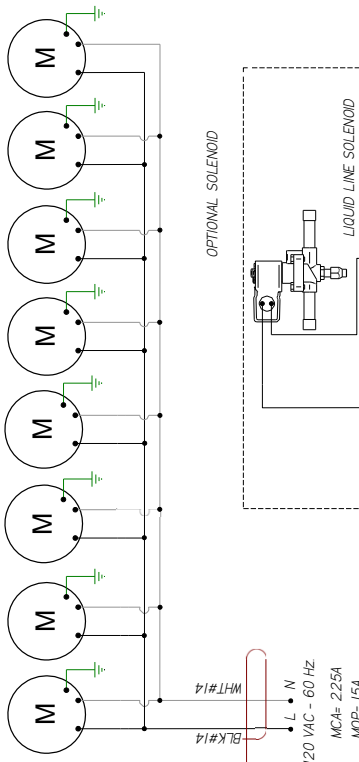

EVAPORATOR FANS  
12W 0.3A @ 120VAC  
181 0477655

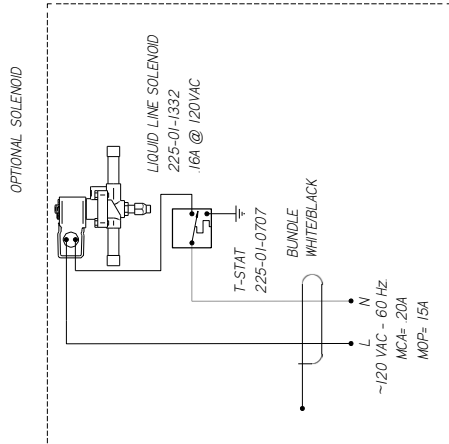

OPTIONAL SOLENOID

LIQUID LINE SOLENOID  
225-01-1832  
16A @ 120VAC

**HUSSMANN**  
DIAGRAM-IY4-6X8C-R  
IH89148 | B

MATERIAL - NA  
DATE DRAWN - 7/11/13  
DRAWN BY - CRAIG BOOREY  
REVIEWED BY - CRAIG BOOREY  
APPROVED BY - CRAIG BOOREY  
UNLESS OTHERWISE SPECIFIED DIMENSIONS ARE IN INCHES  
TOLERANCES ARE:  
THIRD ANGL  
E  
PROJECTION  
DECIMALS .XX ±0.3 .XXX  
±0.0 ANGLES ± 2°

ECN# - 735331 REF - NEW  
DIAGRAM REF - NEW  
DIMENSIONS ARE IN INCHES  
TOLERANCES ARE:  
THIRD ANGL  
E  
PROJECTION  
DECIMALS .XX ±0.3 .XXX  
±0.0 ANGLES ± 2°

NOTES:  
CASE MUST BE GROUNDED

CIRCUIT #

REV	DATE	DESCRIPTION	REV BY	CHKD BY	APPR BY
A	9-19-19	RELEASED TO PRODUCTION	CB	CB	CB

REVISION HISTORY					
REV	DATE	DESCRIPTION	REV BY	CHKD BY	APPR BY
A	9-19-19	RELEASED TO PRODUCTION	CB	CB	CB

CANOPY LIGHTS ES-CANOPY

LIGHT CIRCUIT  
1.25A 134.8W @ 120V

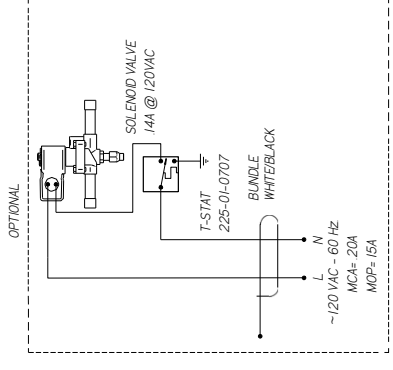
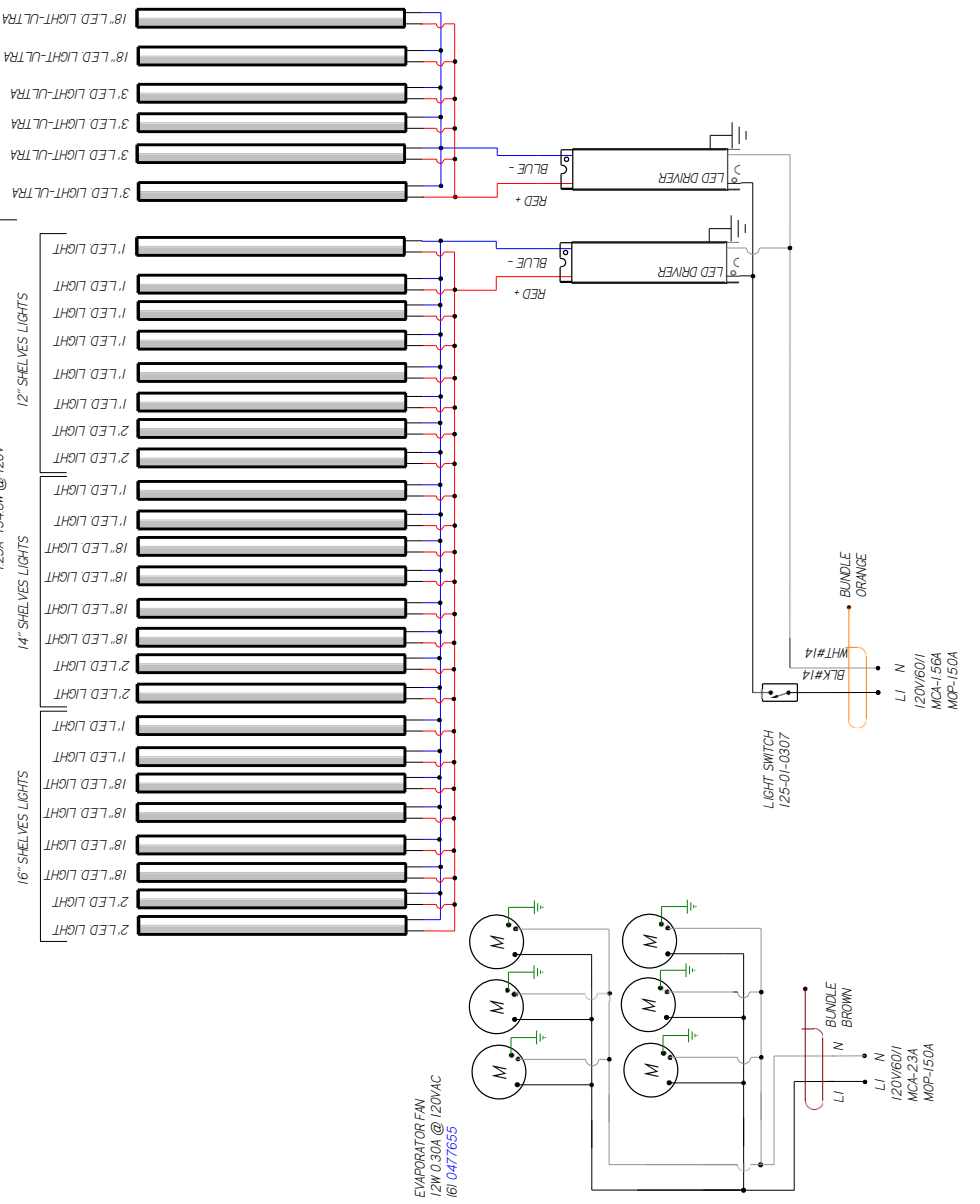

ANTISWEAT HEATER  
120 VAC  
121 0495006 30W, 27A

TAG PURPLE  
HEATER CIRCUIT

WHT # 14  
BLK # 14  
LI N  
120V/60/1  
MCA-1084  
MOP-150A

EVAPORATOR FAN  
2W0.30A @ 120VAC  
161 0417655

LI N  
120V/60/1  
MCA-23A  
MOP-150A

LIGHT SWITCH  
125-01-0307

WHT # 14  
BLK # 14  
LI N  
120V/60/1  
MCA-156A  
MOP-150A

BUNDLE  
ORANGE

WHT # 14  
BLK # 14  
LI N  
120V/60/1  
MCA-156A  
MOP-150A

**HUSSMANN**

DIAGRAM-  
TY4ECRC-6X8I-R

FACTORY 14GA WIRE  
FACTORY 10GA WIRE  
FIELD WIRE

DO NOT SCALE DRAWING  
SHEET 1 OF 1

3107535

UL COLOR CODES / ABBREVIATIONS

- RED = RD
- BLACK = BK
- BLUE = BL
- YELLOW = YL
- GRAY = GR
- WHITE = WT
- GREEN = GN
- BROWN = BN
- ORANGE = OR
- OR VIOLET = VT

- NOTES:
1. PRINTED DOCUMENT REQUIRED SETTING. ALL COLORS BLACK & WHITE
  2. CASE & ANY REMOVABLE PANEL WITH ELECTRICAL PARTS MUST BE GROUNDED.
  3. WHEN PASSING WIRES THROUGH METAL HOLES A GROMMET MUST BE USED

REVISION HISTORY			
REV	ECN	DATE	DESCRIPTION
A	ECN-CAP-0021402	4-30-20	RELEASED TO PRODUCTION
			REV BY / CHKD BY
			APPR BY
			CB
			CB

CIRCUIT #	WIRING	120V	100	120	100

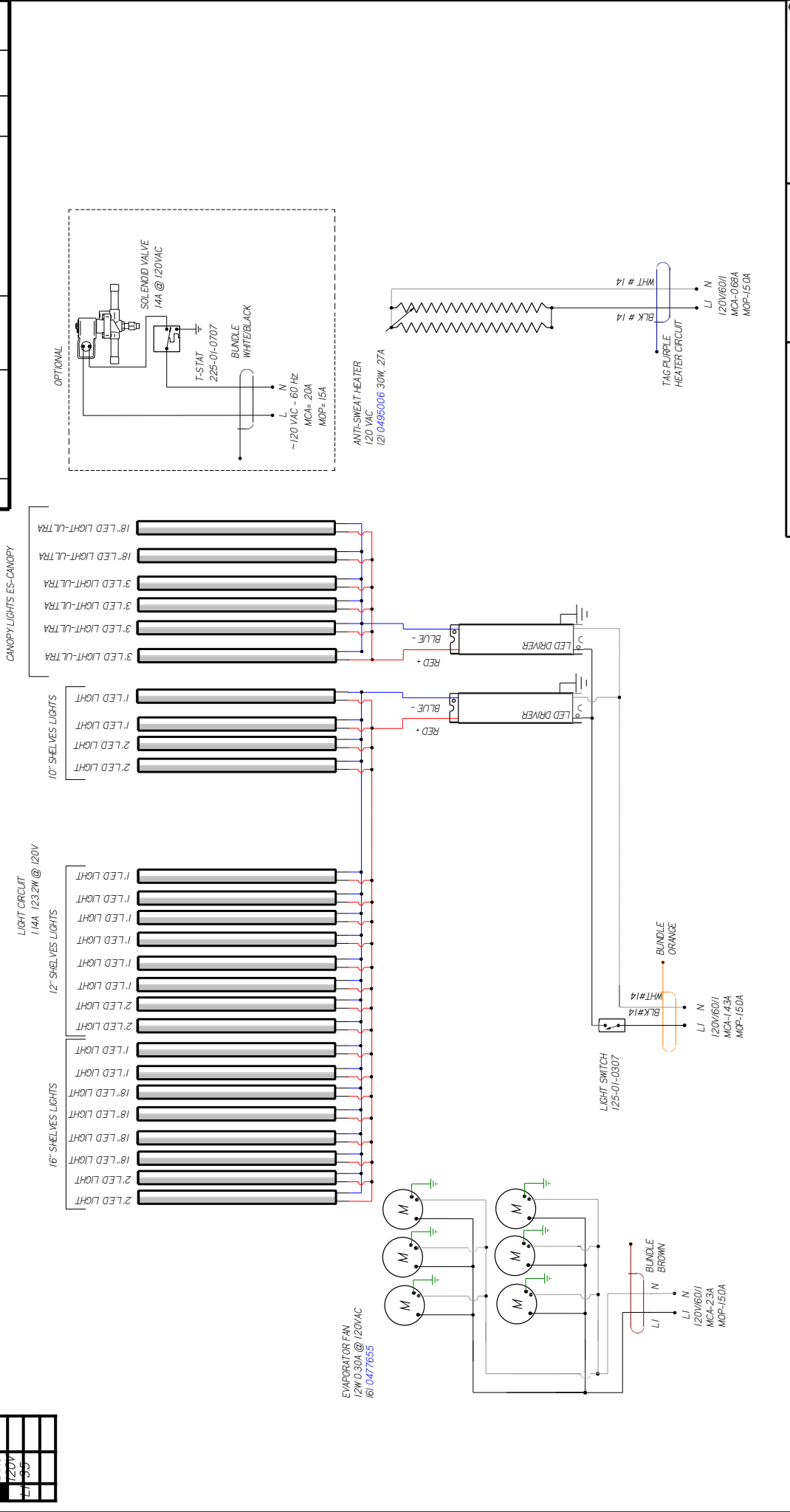

**HUSSMANN**  
**DIAGRAM-**  
**TY4ECRC-6X81-R**  
**W10",12" &**  
**16" 315818**  
**10375818**  
**SHEET 1 OF 1**

UL COLOR CODES / ABBREVIATIONS  
 RED = RD  
 BLACK = BK  
 BLUE = BL  
 YL GRAY =  
 CY  
 WHITE = WT  
 GREEN = GN  
 BROWN = BN  
 ORANGE =  
 OR VIOLET =  
 VT

FACTORY 14GA WIRE  
 -FACTORY 10GA WIRE  
 -FIELD WIRE  
 -

DO NOT SCALE DRAWING  
 SHEET 1 OF 1

- NOTES:
1. PRINTED DOCUMENT REQUIRED SETTING. ALL COLORS BLACK & WHITE
  2. CASE & ANY REMOVABLE PANEL WITH ELECTRICAL PARTS MUST BE GROUNDED.
  3. WHEN PASSING WIRES THROUGH METAL HOLES A GROMMET MUST BE USED

CIRCUIT #1

ENDING	
120V	
11-17	

REVISION HISTORY		REVISION DESCRIPTION		REV BY	CHKD BY	APPR BY
1	ECN-CAP-002886	2018/05/25	RELEASED TO PRODUCTION	CB	CB	CB

LIGHT CIRCUIT  
160A 1724W @ 120V

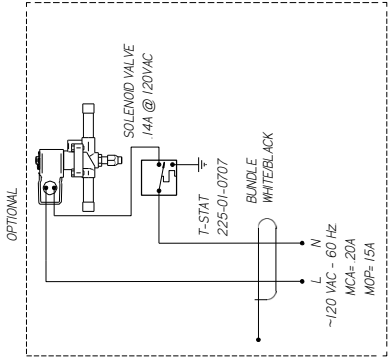
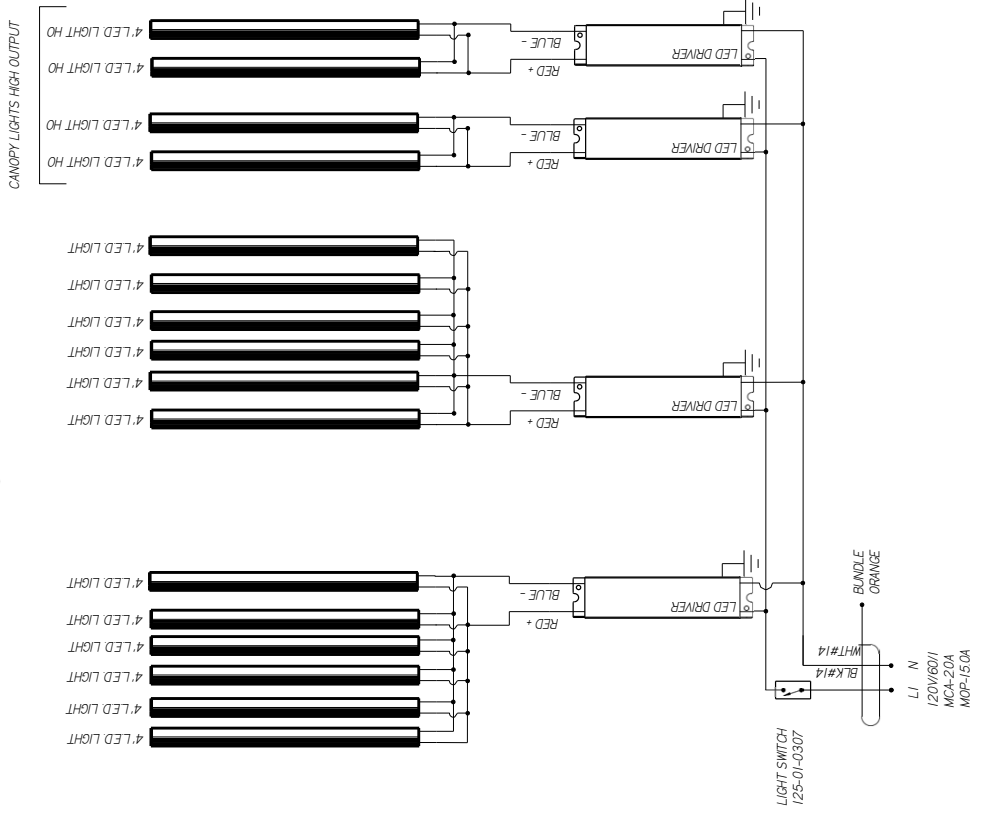

ANTI-SWEAT HEATER  
120 VAC  
121 0485007 40W, 33A

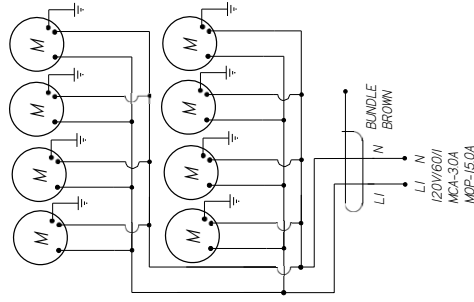

MATERIAL - N/A  
DATE DRAWN - 5-25-18  
DRAWN BY - CRAIG BOOREY  
REVIEWED BY - CRAIG BOOREY  
APPROVED BY - CRAIG BOOREY  
UNLESS OTHERWISE SPECIFIED DIMENSIONS ARE IN INCHES  
TOLERANCES ARE:  
DECIMALS .XX ±0.3 .XXX  
±0.0  
ANGLES ± 2°  
PROJECTION  
E  
A

**HUSSMANN**  
DIAGRAM-  
TY4ECRC- 6X8C-R

ECN-CAP-0012696  
REF -  
SHEET 1 OF 1  
DIMENSIONS ARE IN INCHES  
TOLERANCES ARE:  
DECIMALS .XX ±0.3 .XXX  
±0.0  
ANGLES ± 2°  
PROJECTION  
E  
A

3064025 | A



NOTES:  
CASE MUST BE GROUNDED  
WHEN PASSING WIRES THROUGH METAL HOLES A GROMMET MUST BE USED

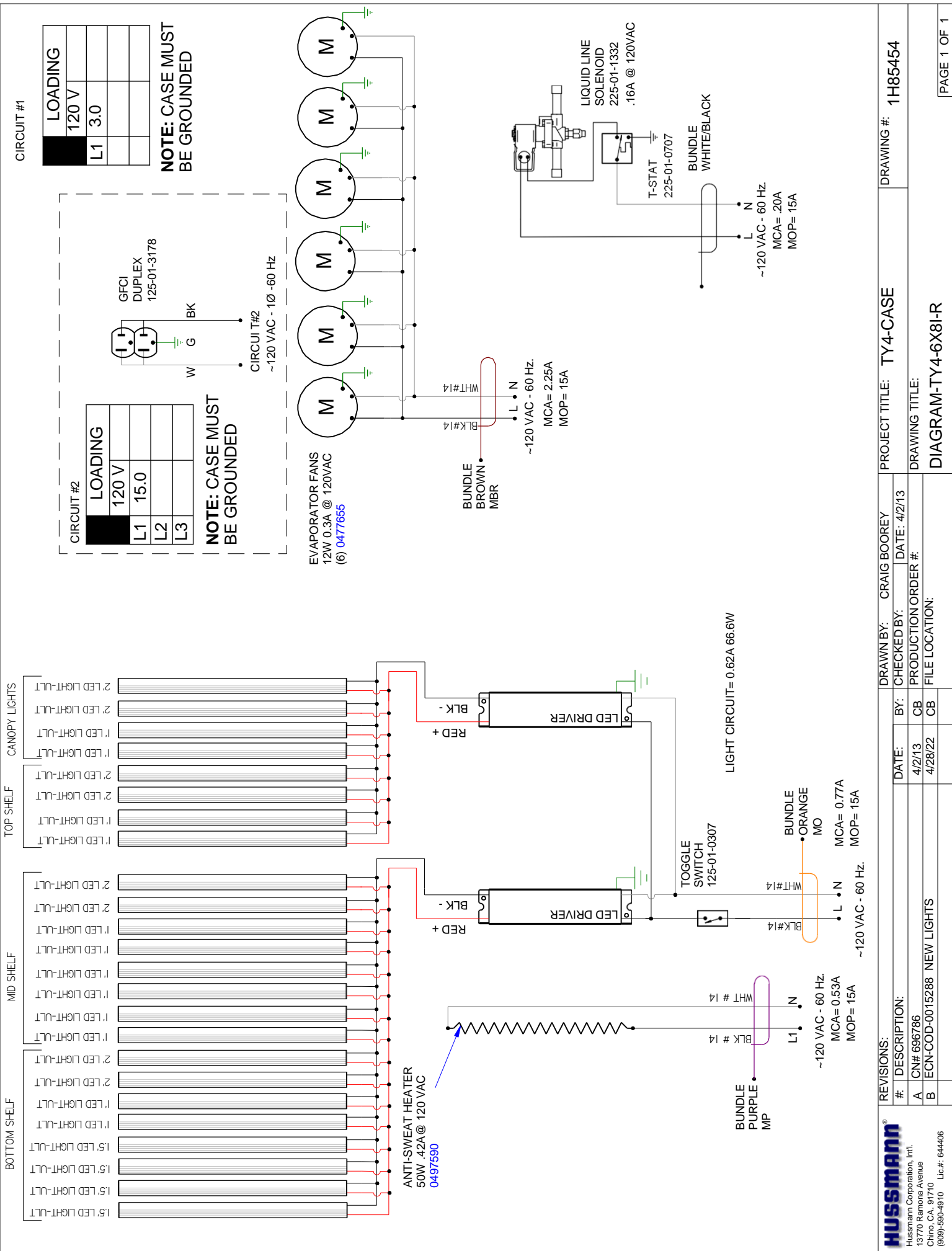

CIRCUIT #1

CIRCUIT #2	LOADING
L1	3.0
L2	
L3	

**NOTE: CASE MUST BE GROUNDED**

CIRCUIT #2

CIRCUIT #2	LOADING
L1	15.0
L2	
L3	

**NOTE: CASE MUST BE GROUNDED**

CIRCUIT #3

CIRCUIT #2	LOADING
L1	3.0
L2	
L3	

**NOTE: CASE MUST BE GROUNDED**

CIRCUIT #4

CIRCUIT #2	LOADING
L1	15.0
L2	
L3	

**NOTE: CASE MUST BE GROUNDED**

CIRCUIT #5

CIRCUIT #2	LOADING
L1	3.0
L2	
L3	

**NOTE: CASE MUST BE GROUNDED**

CIRCUIT #6

CIRCUIT #2	LOADING
L1	3.0
L2	
L3	

**NOTE: CASE MUST BE GROUNDED**

CIRCUIT #7

CIRCUIT #2	LOADING
L1	3.0
L2	
L3	

**NOTE: CASE MUST BE GROUNDED**

**REVISIONS:**

#	DESCRIPTION:	DATE:	BY:
A	CN# 696786	4/2/13	CB
B	ECN-COD-0015288 NEW LIGHTS	4/28/22	CB

**PROJECT TITLE: TY4-CASE**

**DRAWING #: 1H85454**

**DRAWING TITLE: DIAGRAM-TY4-6X8I-R**

**DRAWN BY: CRAIG BOOREY**

**CHECKED BY:**

**DATE: 4/2/13**

**PRODUCTION ORDER #:**

**FILE LOCATION:**

**HUSMANN®**  
Hussmann Corporation, Intl.  
13770 Ramona Avenue  
Chino, CA. 91710  
(800)-590-4910 Lic.#: 644406

PAGE 1 OF 1

REVISION HISTORY			
REV	EN	DATE	REV BY / CHG BY / APPR BY
A	765011	2023/10/22	CB / CB / CB
B	ECM-CDD-0018288	2022/04/28	CB / CB / CB
REVISION DESCRIPTION		NEW DIAGRAM	
		NEW LIGHTS	

CIRCUIT #1	LOADING
120V	
L1	150
L2	
L3	

CIRCUIT #2	LOADING
120	
L1	150
L2	
L3	

CIRCUIT #2	LOADING
120	
L1	150
L2	
L3	

CIRCUIT #2	LOADING
120	
L1	150
L2	
L3	

CIRCUIT #2	LOADING
120	
L1	150
L2	
L3	

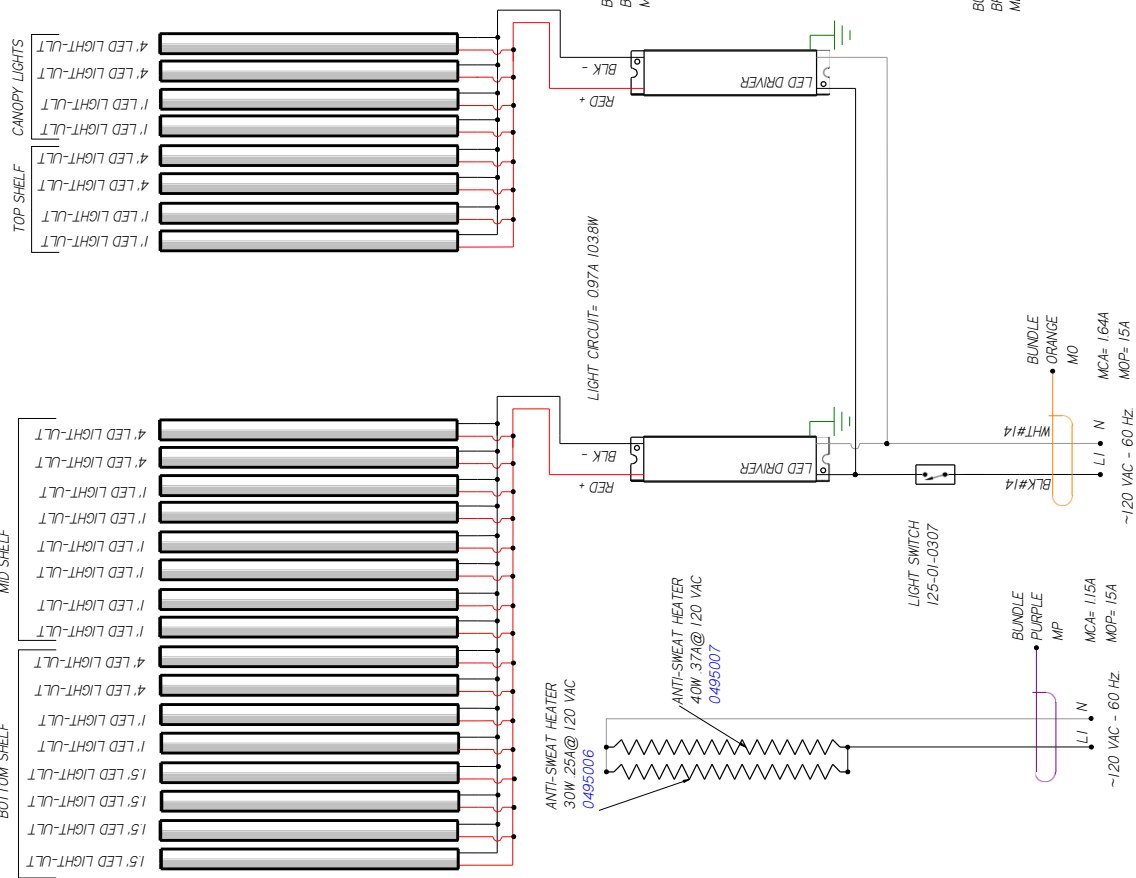
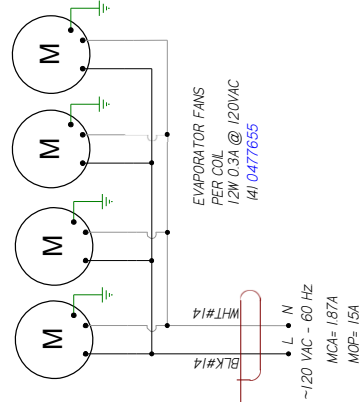
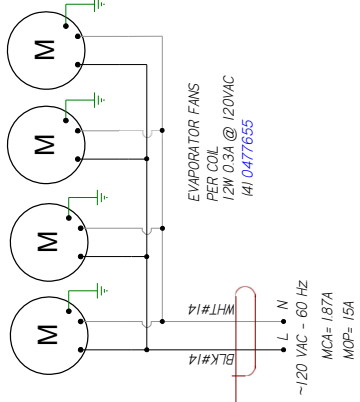
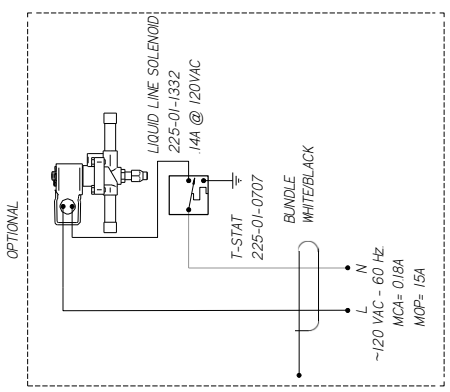
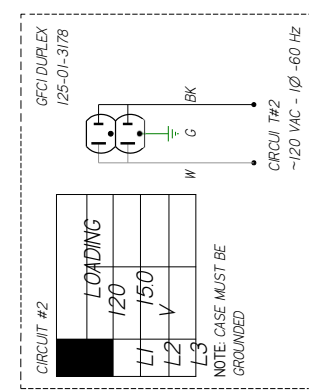

MATERIAL - N/A  
 DATE DRAWN - 10/22/13  
 DRAWN BY - CRAIG BOOREY  
 REVIEWED BY - CRAIG BOOREY  
 APPROVED BY - CRAIG BOOREY  
 UNLESS OTHERWISE SPECIFIED DIMENSIONS ARE IN INCHES  
 TOLERANCES ARE:  
 DECIMALS .XX ±0.3, .XXX  
 ANGLES ± 2°  
 PROJECTION

**HUSSMANN**  
 DIAGRAM -  
 TY4-6X101-  
 R  
 IH93524 | B

NOTES:  
 CASE MUST BE GROUNDED

REVISION HISTORY		REV	DATE	DESCRIPTION	BY	CHKD BY	APPR BY
B	248653	2013/06/02	MATCH FAN REVISION	CY	CY	CB	CB
C	ECN# 001-0162683	2022/05/02	NEW LIGHTS	CB	CB	CB	CB

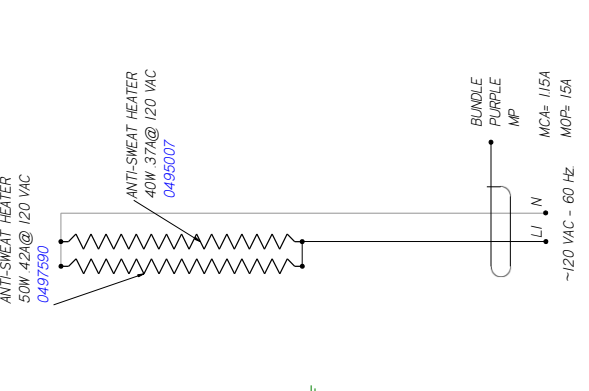
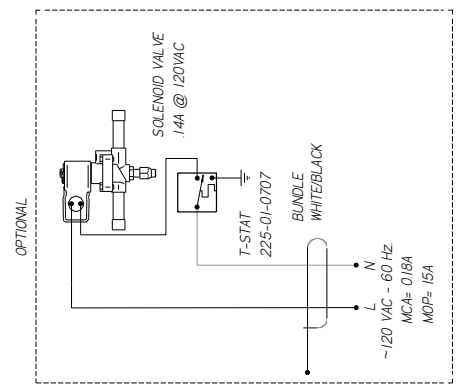
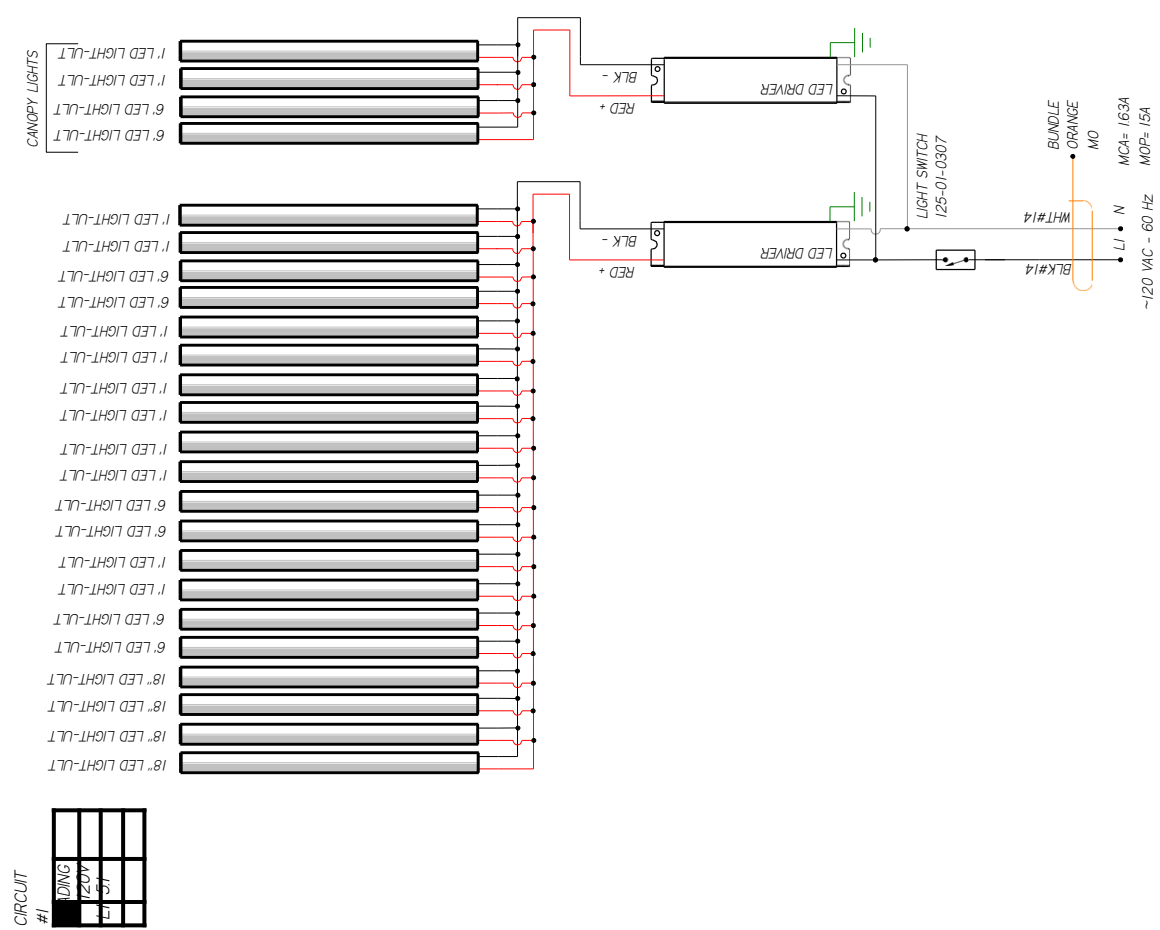
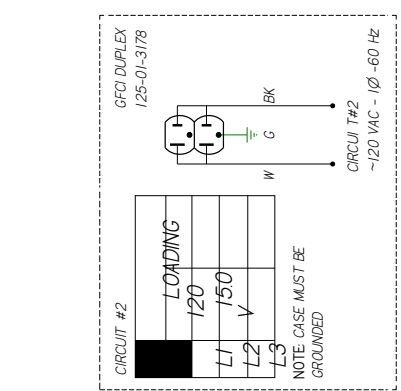

**HUSSMANN**

**DIAGRAM - TY4-6X12- R**

**IH91310 | C**

MATERIAL - NA  
 DATE DRAWN - 8/27/13  
 DRAWN BY - CRAIG BOOREY  
 REVIEWED BY - CRAIG BOOREY  
 APPROVED BY - CRAIG BOOREY  
 UNLESS OTHERWISE SPECIFIED DIMENSIONS ARE IN INCHES  
 TOLERANCES ARE:  
 FRACTIONS XX ± 0.3, XXX ± 0.0  
 ANGLES ± 2°  
 PROJECTION

NOTES:  
CASE MUST BE GROUNDED

REVISION HISTORY		REV	BY	CHG	BY	APPR	BY
A	ECN-CAP-0009957	2017/04/27	CB	CB	CB	CB	CB
B	ECN-CAP-0015289	2022/05/02	CB	CB	CB	CB	CB

REVISION DESCRIPTION	NEW LIGHTS
A	
B	

CIRCUIT #1	LOADING	120V	150V
L1			
L2			
L3			

NOTE: CASE MUST BE GROUNDED

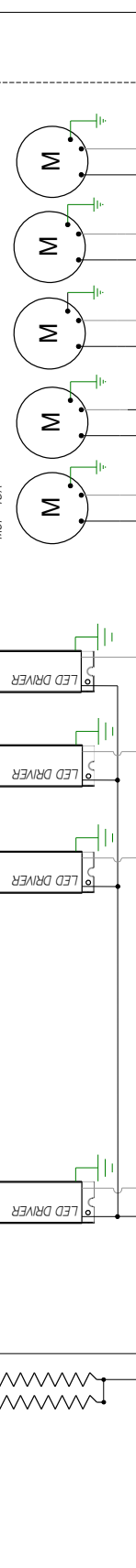
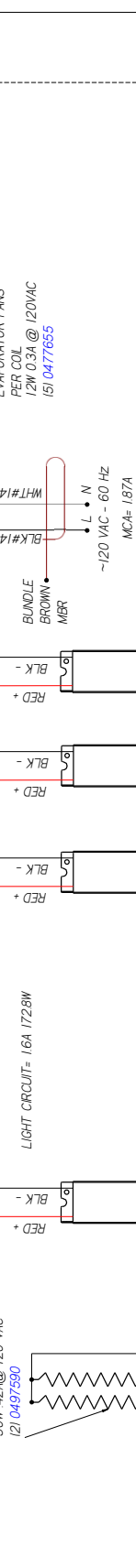
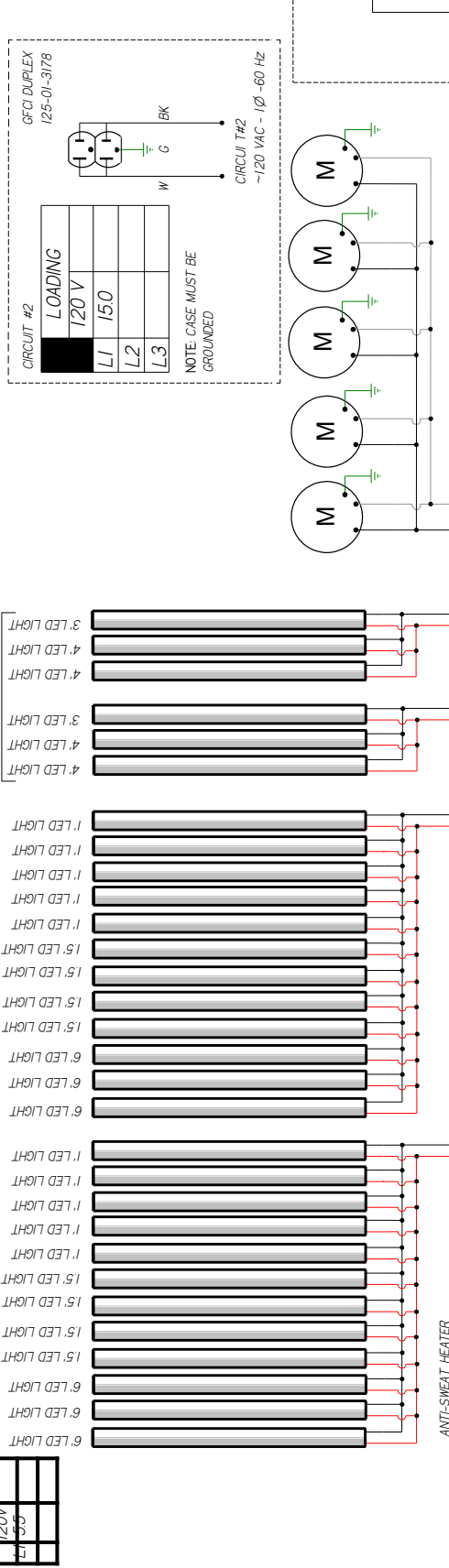

**MATERIAL - NA**  
 DATE DRAWN - 10-17-17  
 DRAWN BY - CRAIG BOOREY  
 REVIEWED BY - CRAIG BOOREY  
 APPROVED BY - CRAIG BOOREY  
 UNLESS OTHERWISE SPECIFIED DIMENSIONS ARE IN INCHES  
 TOLERANCES ARE:  
 FRACTIONS XX ± 0.3, XXX  
 DECIMALS .XX ± 0.03, .XXX  
 ANGLES ± 2°  
 PROJECTION

**HUSSMANN**  
**DIAGRAM-**  
**TY4ECRC- 6X121-R**

ECN-CAP-0009957  
 REF -  
 SHEET 1 OF 1

3047242 | B

NOTES:  
 CASE MUST BE GROUNDED  
 WHEN PASSING WIRES THROUGH METAL HOLES A GROMMET MUST BE USED



REVISION HISTORY			
REV	ECN	DATE	DESCRIPTION
A	ECN-CAP-0016780	4-1-19	RELEASED TO PRODUCTION
B	FCN-COD-0016288	5-2-22	NEW LIGHTS

REVISION HISTORY			
REV	BY	CHKD	BY
CB	CB	CB	CB
CB	CB	CB	CB

CIRCUIT #2	LOADING
L1	120 V
L2	150
L3	

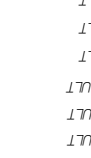

NOTE: CASE MUST BE GROUNDED

CIRCUIT #1

CIRCUIT #1	LOADING
L1	120V
L2	150
L3	

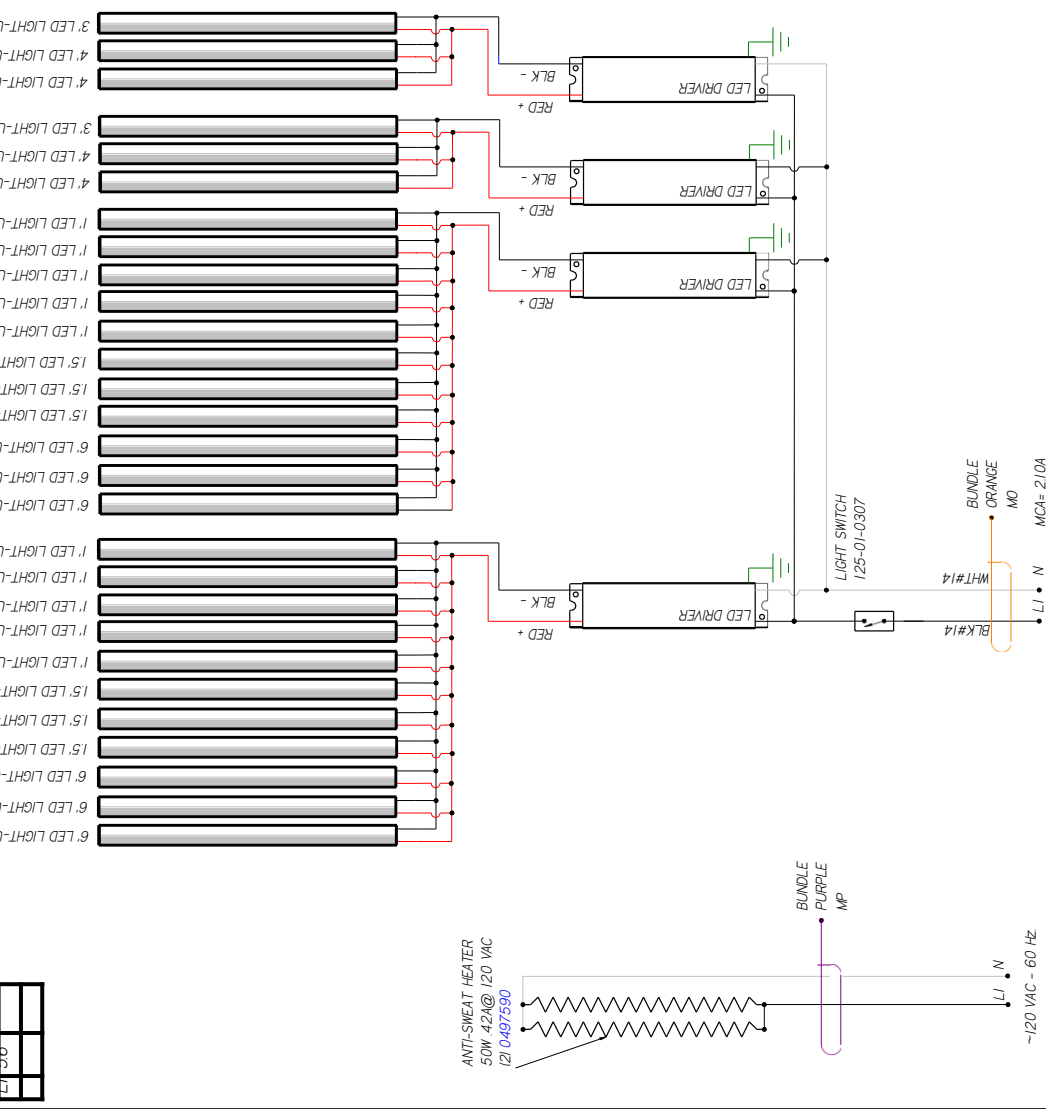
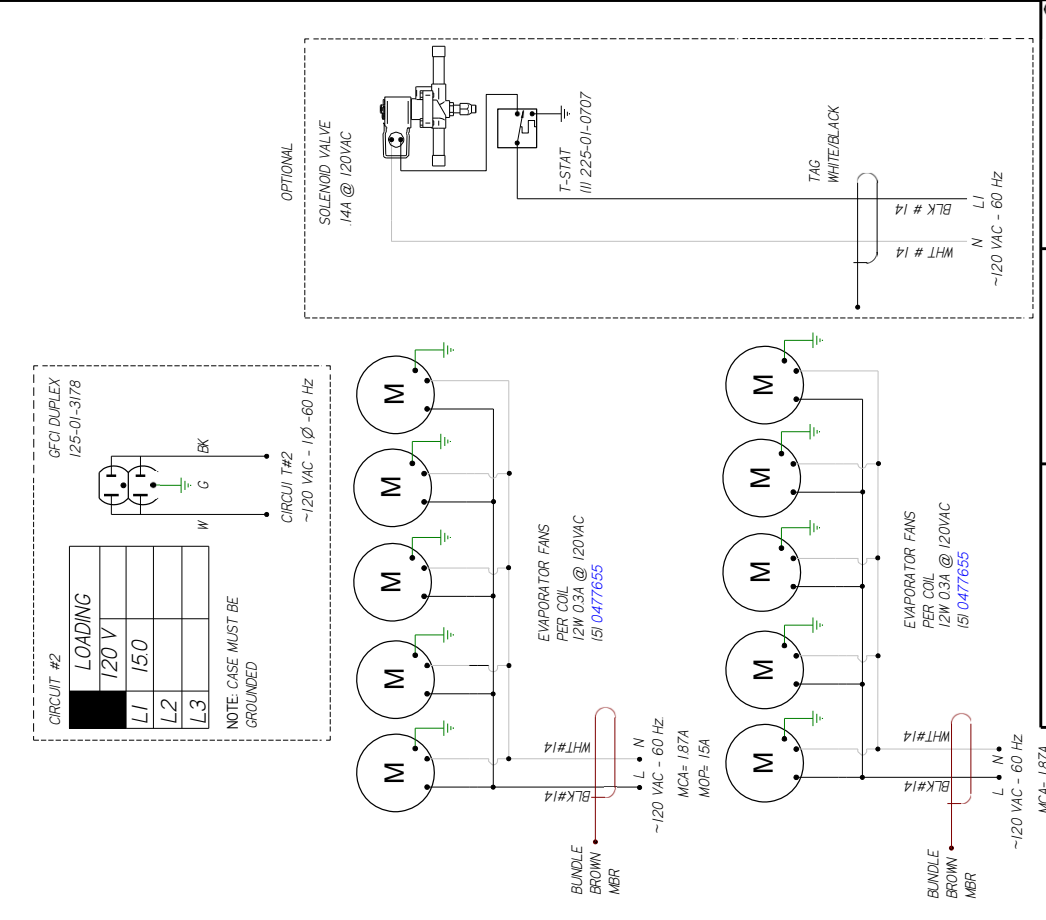

**HUSSMANN**  
**DIAGRAM-**  
**TY4ECRC- 6X12-I-R,**  
**12",14",16" SHELVES**

UL COLOR CODES / ABBREVIATIONS
RED = RD
BLACK = BK
BLUE = BL
YELLOW = YL
GRAY = GR
WHITE = WT
GREEN = GN
BROWN = BN
ORANGE = OR
VIOLET = VT

FACTORY 14GA WIRE
FACTORY LOGA WIRE
FIELD WIRE

DO NOT SCALE DRAWING  
 SHEET 1 OF 1

3092240

- NOTES:
1. PRINTED DOCUMENT REQUIRED SETTING: ALL COLORS BLACK & WHITE
  2. CASE MUST BE GROUNDED
  3. WHEN PASSING WIRES THROUGH METAL HOLES A GROMMET MUST BE USED



OPTIONAL LEDGE LIGHTS

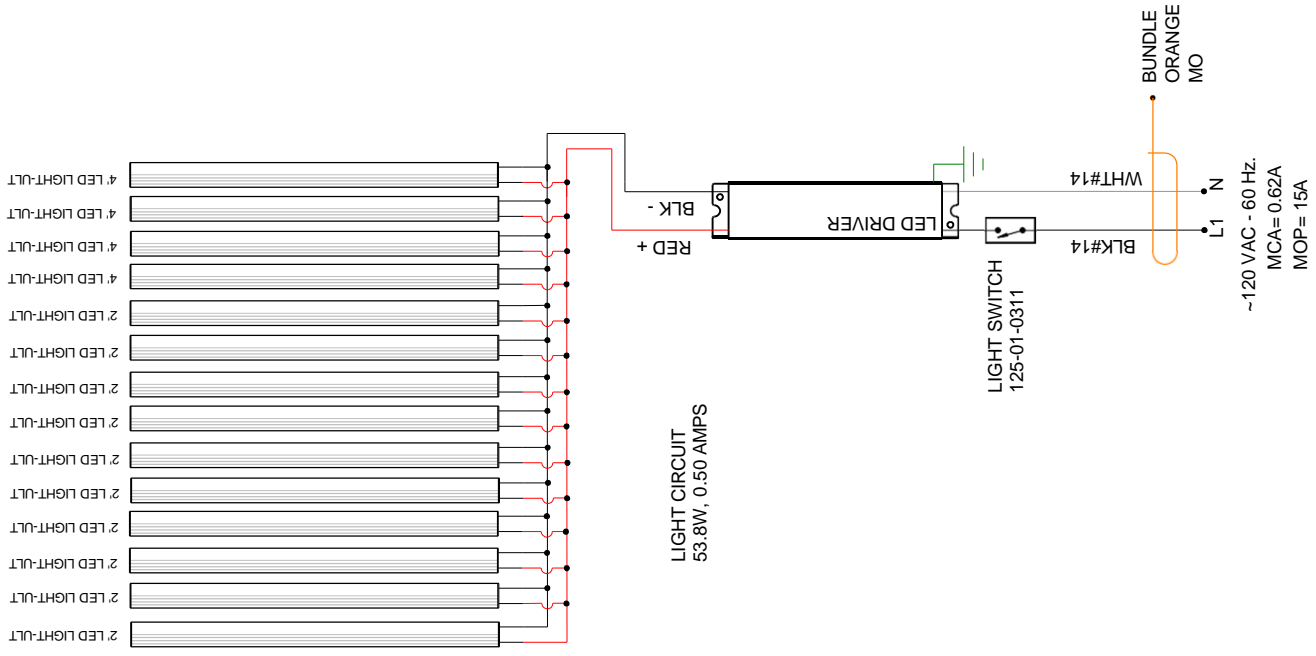

CIRCUIT #2	LOADING
	120 V
L1	15.0
L2	
L3	

GFCI DUPLEX 125-01-3178

W G BK

CIRCUIT #2  
~120 VAC - 1Ø - 60 Hz

**NOTE: CASE MUST BE GROUNDED**

REVISIONS:	DESCRIPTION:	DATE:	BY:	CHECKED BY:	DATE:
A	CNF#696786	2/27/13	CB		
B	ECN-COD-0015284 ADDED OPTIONAL LEDGE LIGHTS	4/11/22	CB		

FILE LOCATION: #268625

REVISION HISTORY		REV BY	CHKD BY	APPR BY
1	ECN-CAP-0009957	2007/01/06	CB	CB
REVISION DESCRIPTION		REV BY	CHKD BY	APPR BY
RELEASED TO PRODUCTION		CB	CB	CB

CIRCUIT #1	LOADING
120V	
L1	6.8
L2	
L3	

CIRCUIT #2	LOADING
120 V	
L1	15.0
L2	
L3	

NOTE: CASE MUST BE GROUNDED

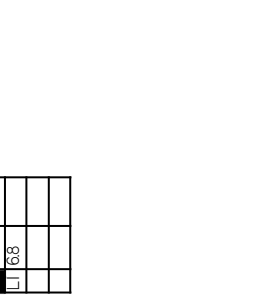
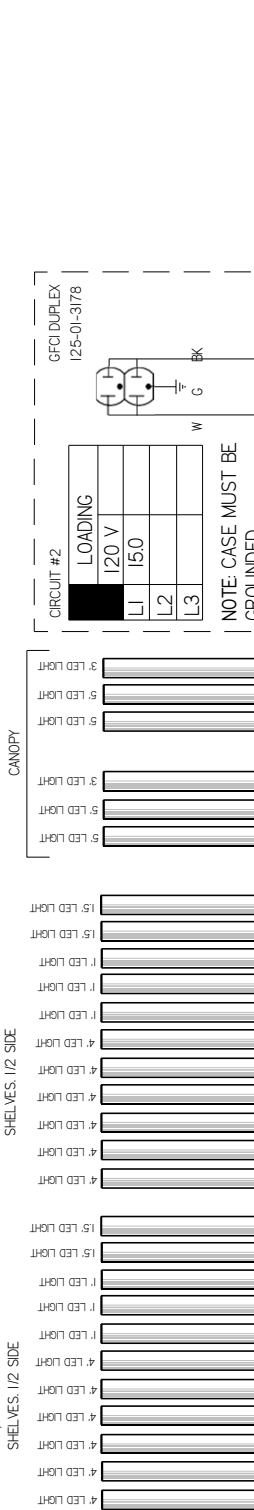
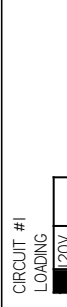

NOTES:  
CASE MUST BE GROUNDED  
WHEN PASSING WIRES THROUGH METAL HOLES A GROMMET MUST BE USED

MATERIAL - NA  
DATE DRAWN - 10-16-17  
DRAWN BY - CRAIG BOOREY  
REVIEWED BY - CRAIG BOOREY  
APPROVED BY - CRAIG BOOREY  
UNLESS OTHERWISE SPECIFIED DIMENSIONS ARE IN INCHES  
TOLERANCES ARE:  
DECIMALS .XX +0.3 .XXX +0.10  
ANGLES ± 2°

HUSSMANN  
DIAGRAM-FY4ECRC-  
6X141-R

3047157

PRODUCTION

LIGHT CIRCUIT= 2.02A 218.2W

BOTTOM SHELF

MID SHELF

TOP SHELF

CANOPY LIGHTS

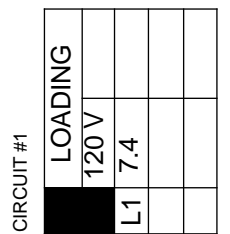
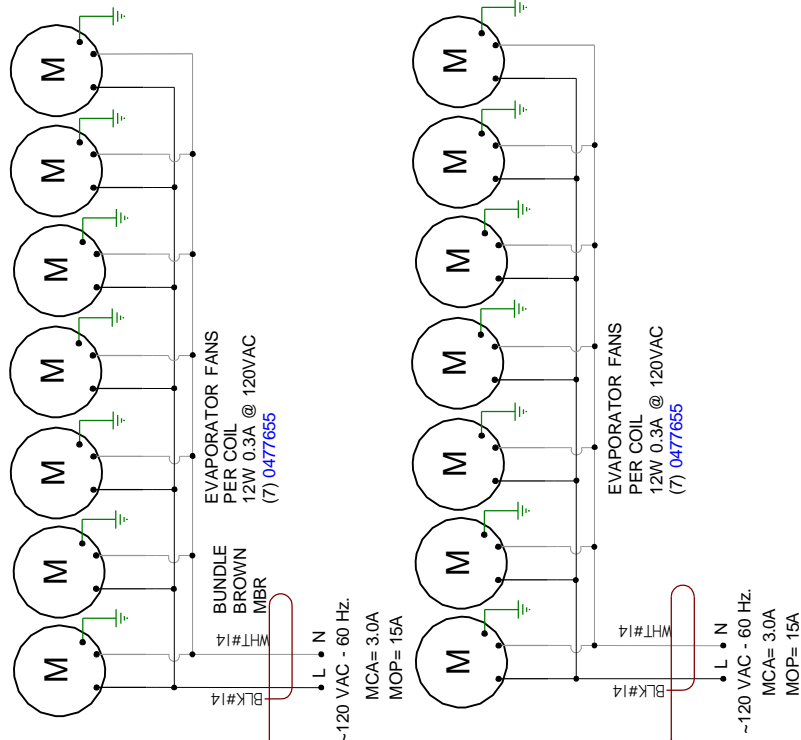
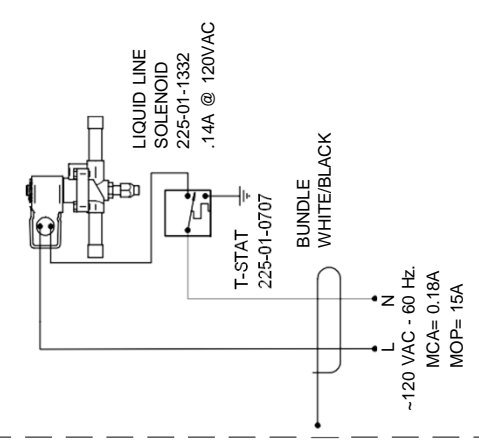
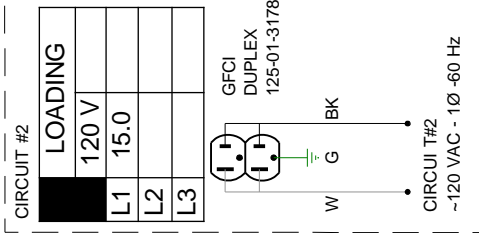
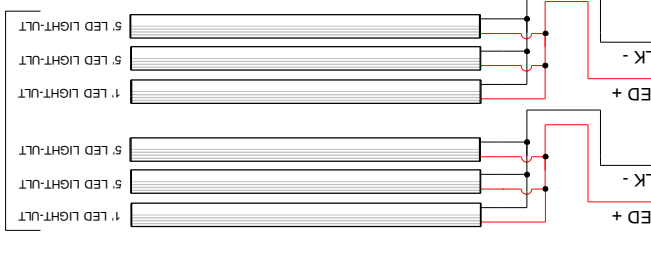
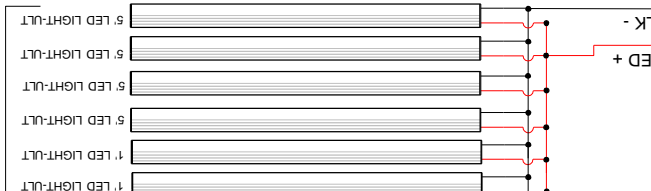
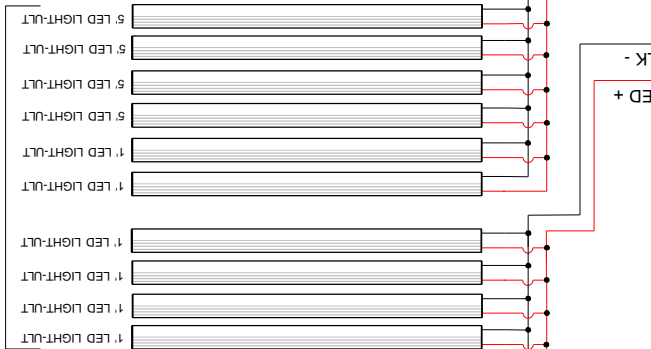
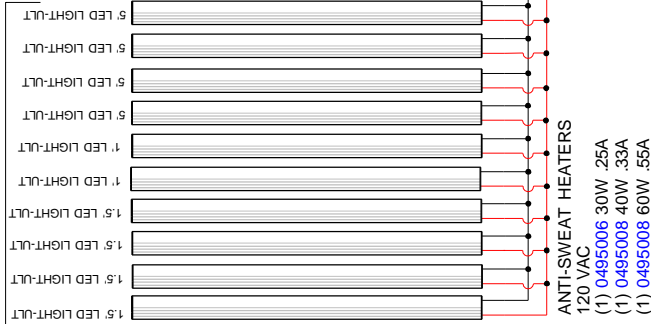

**NOTE: CASE MUST BE GROUNDED**

REVISIONS:

#	DESCRIPTION:	DATE:	BY:
A	CN#696786	3/25/13	CB
B	CN#980241 CHANGED ANTI-SWEAT HEATER	4/21/15	CB
C	ECN-COD-0015289 NEW LIGHTS	5/3/22	CB

FILE LOCATION:

FILE LOCATION:	DATE:	BY:
	3/25/13	CB
	4/21/15	CB
	5/3/22	CB

DRAWN BY: CRAIG BOOREY  
 CHECKED BY: DATE: 3/25/13  
 PRODUCTION ORDER #: 632101

PROJECT TITLE: TY4-CASE  
 DRAWING TITLE: DIAGRAM-TY4-6X161-R

REVISION HISTORY			
REV	EN	DATE	DESCRIPTION
A	ECN-CAP-0009102	2017/04/27	RELEASED TO PRODUCTION
B	ECN-CAP-0014600	2020/09/22	UPDATED LIGHT LAYOUT

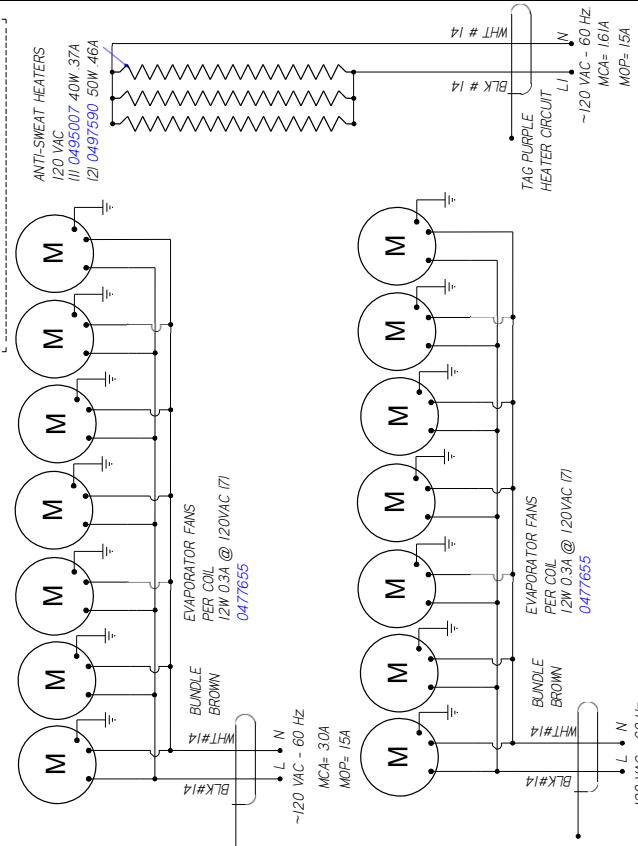
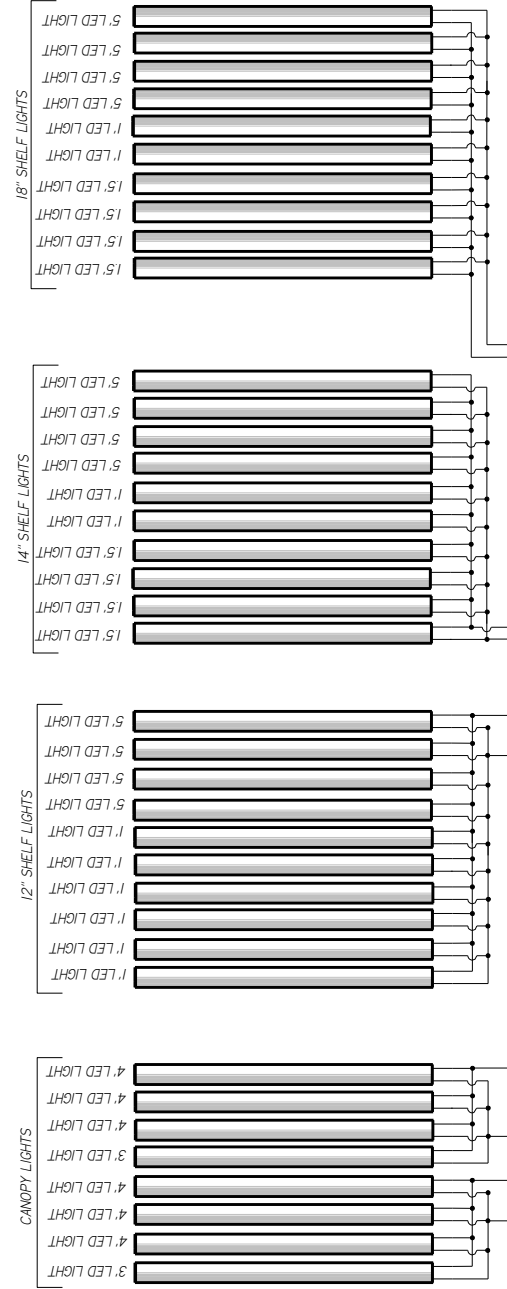
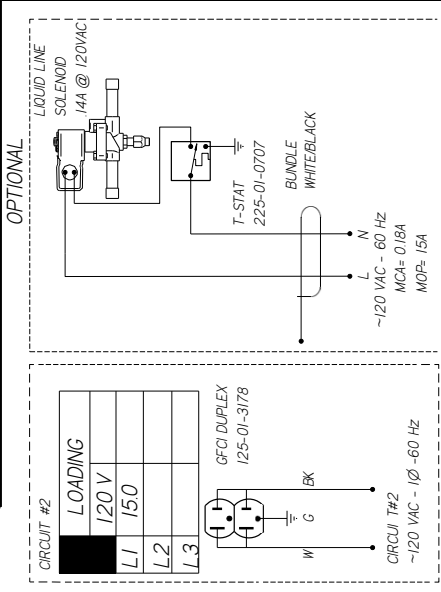

LOADING	
120 V	
L1	8.7

**HUSSMANN**  
**DIAGRAM-**  
**TY4ECRC- 6X161R**

MATERIAL - NA  
DATE DRAWN - 9-7-17  
DRAWN BY - CRAIG BOOREY  
REVIEWED BY - CRAIG BOOREY  
APPROVED BY - CRAIG BOOREY  
UNLESS OTHERWISE SPECIFIED DIMENSIONS ARE IN INCHES  
TOLERANCES ARE:  
DECIMALS .XX ±0.3 .XXX  
±0.0  
ANGLES ± 2°  
PROJECTION

REF -  
SHEET NO  
THIRD

CON-CAP-0009102

3043948 | B

NOTES:  
CASE MUST BE GROUNDED  
WHEN PASSING WIRES THROUGH METAL HOLES A GROMMET MUST BE USED

REVISION HISTORY		DATE	REVISION DESCRIPTION	REV BY	CHKD BY	APPR BY
REV	ECN					
A	ECN-COD-0015266	1-13-22	RELEASED TO PRODUCTION	CB	CB	CB

CIRCUIT #1	LOADING
	120 V
	10.4

LIGHT CIRCUIT = 4.2A 452.6W

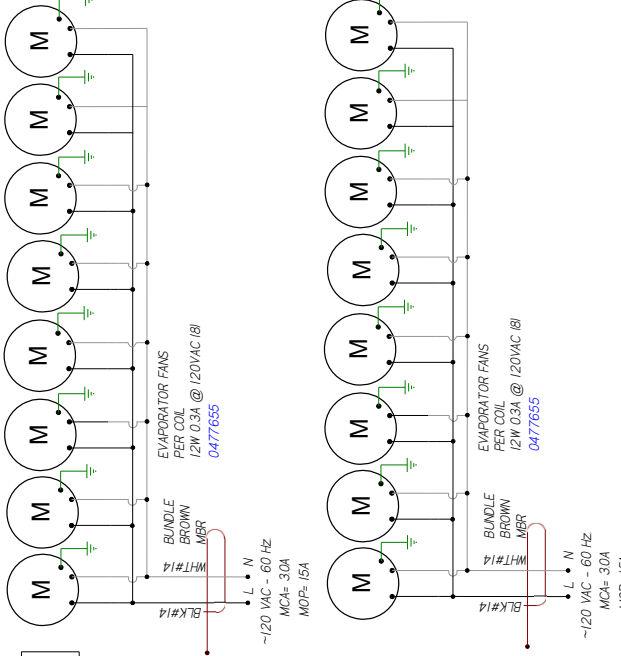
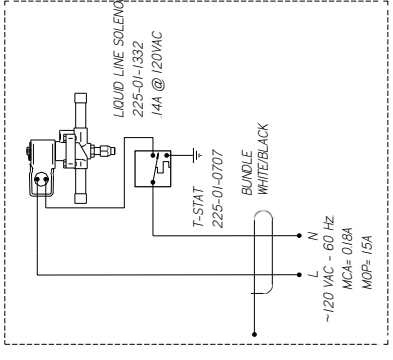
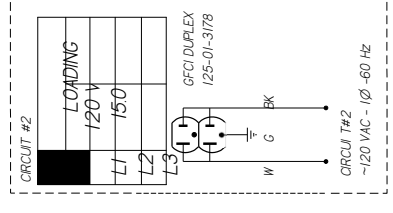
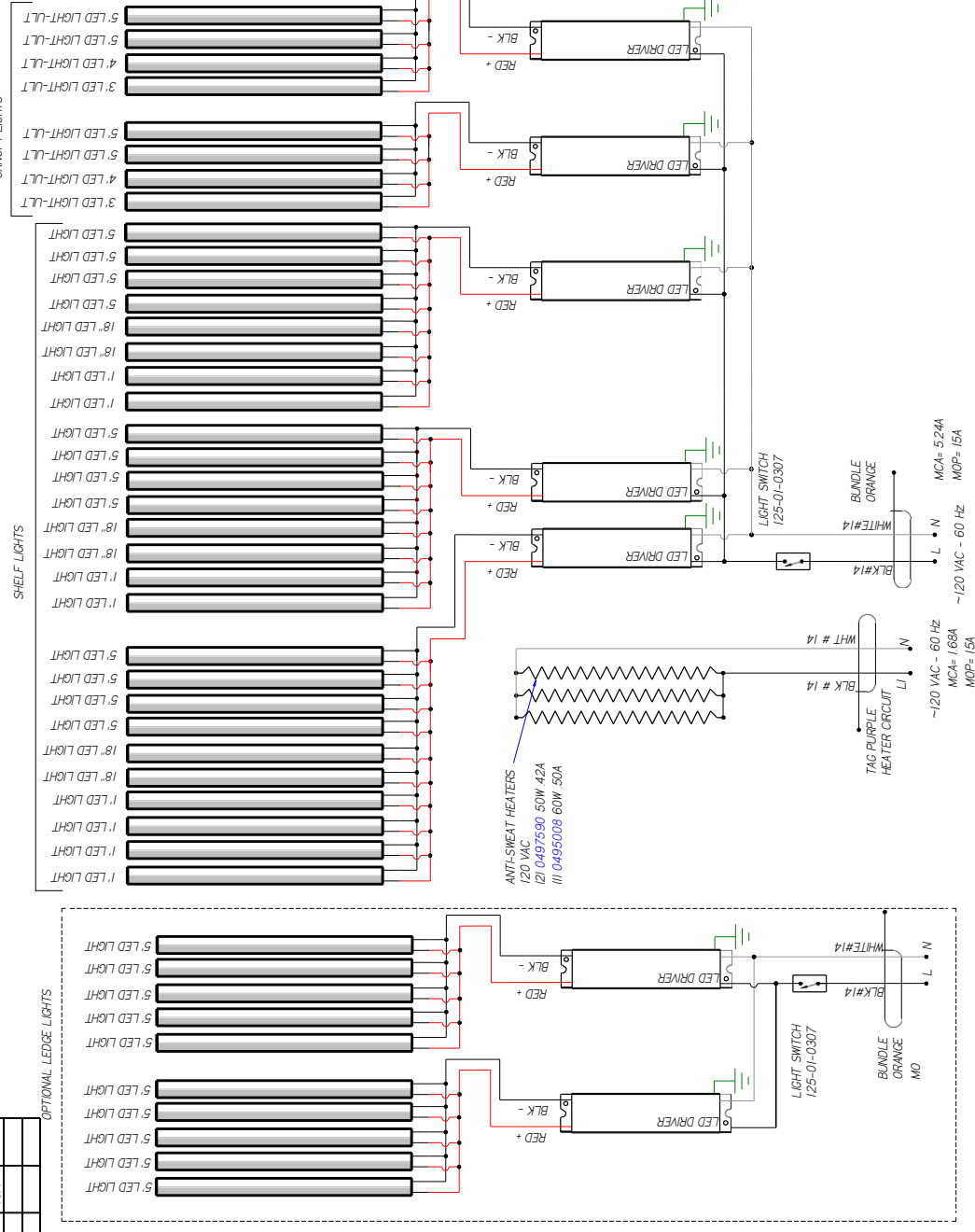

**WIRE MARKER COLORS/ABBREVIATIONS**

MAROON =	WT
MAR ORANGE =	GN
MG PINK =	BN
MP =	MP
MAR =	MR
MG =	MG
MLB =	MYL
MEK =	BLK
MEL =	BLU
MBR =	BRO
MPI =	DKB
MGP =	DGR
MGB =	DRK
MGL =	GRN
MML =	GY

**UL COLOR CODES / ABBREVIATIONS**

RED =	RD
BLACK =	BLK
BLUE =	BL
YELLOW =	YL
GRAY =	GR
WHITE =	WT
GREEN =	GN
BROWN =	BN
ORANGE =	OR
VIOLET =	VT

- NOTES:**
1. PRINTED DOCUMENT REQUIRED SETTING. ALL COLORS BLACK & WHITE
  2. CASE & ANY REMOVABLE PANEL WITH ELECTRICAL PARTS MUST BE GROUNDED.
  3. WHEN PASSING WIRES THROUGH METAL HOLES A GROMMET MUST BE USED

**HUSSMANN**  
DIAGRAM-  
TY4ECRC-6X181-R  
DO NOT SCALE DRAWING  
SHEET 1 OF 1

FACTORY 14GA WIRE  
FACTORY 10GA WIRE  
FIELD WIRE  
DO NOT SCALE DRAWING  
SHEET 1 OF 1

3160164  
A



## User Information

### Stocking

Improper temperature and lighting will cause serious product loss. Discoloration, dehydration and spoilage can be controlled with proper use of the equipment and handling of product. Product temperature should always be maintained at a constant and proper temperature. This means that from the time the product is received, through storage, preparation and display, the temperature of the product must be controlled to maximize life of the product. Hussmann cases were not designed to “heat up” or “cool down” product - but rather to maintain an item’s proper temperature for maximum shelf life. To achieve the protection required always:

1. Minimize processing time to avoid damaging temperature rise to the product. Product should be at proper temperature.
2. Keep the air in and around the case area free of foreign gasses and fumes or food will rapidly deteriorate.
3. Maintain the display merchandisers temperature controls as outlined in the refrigerator section of this manual.
4. Do not place any product into these refrigerators until all controls have been adjusted and they are operating at the proper temperature. Allow merchandiser to operate a minimum of one (1) hour before stocking with any product.
5. When stocking, never allow the product to extend beyond the recommended load limit. Air discharge and return air fl ue must be unobstructed at all times to provide proper refrigeration.
6. Avoid the use of supplemental fl ood or spot lighting. Display light intensity has been designed for maximum visibility and product life at the factory. The use of higher output fl uorescent lamps (H.O. and V.H.O.), will shorten the shelf life of the product.

### Case Cleaning

Long life and satisfactory performance of any equipment are dependent upon the care given to it. To insure long life, proper sanitation and minimum maintenance costs, the refrigerator should be thoroughly cleaned frequently. SHUT OFF FAN DURING CLEANING PROCESS. It can be unplugged within the case, or shut off entire case at the source. The interior bottom may be cleaned with any domestic soap or detergent based cleaners. Sanitizing solutions will not harm the interior bottom, however, these solutions should always be used according to the Hussmann’s directions. It is essential to establish and regulate cleaning procedures. This will minimize bacteria causing discoloration which leads

to degraded product appearance and significantly shortening product shelf life.

Soap and hot water are not enough to kill this bacteria. A sanitizing solution must be included with each cleaning process to eliminate this bacteria.

1. Scrub thoroughly, cleaning all surfaces, with soap and hot water.
2. Rinse with hot water, but do not flood.
3. Apply the sanitizing solution according to Hussmann’s directions.
4. Rinse thoroughly.
5. Dry completely before resuming operation.

### Plexiglass and Acrylic Care

Improper cleaning not only accelerates the cleaning cycle but also degrades the quality of this surface. Normal daily buffing motions can generated static cling attracting dust to the surface. Incorrect cleaning agents or cleaning cloths can cause micro scratching of the surface, causing the plastic to haze over time.

### Cleaning

Hussmann recommends using a clean damp chamois, or a paper towel marked as “dust and abrasive free” with 210® Plastic Cleaner and Polish available by calling Sumner Labs at 1-800-542-8656. Hard, rough cloths or paper towels will scratch the acrylic and should not be used.

## Troubleshooting

### Troubleshooting Guide

Problem	Possible Cause	Possible Solution
<b>Case temperature is too warm.</b>	Ambient conditions may be affecting the case operation.	Check case position in store. Is the case located near an open door, window, electric fan or air conditioning vent that may cause air currents? See page 5 for details. Provide shading for the case or move out of direct sunlight. Move the case away from or block air ventilation currents aimed directly at the case. Case must be located minimum 15 Ft away from doors or windows. Cases are designed to operate at 55% Relative humidity and a temperature of 75°F.
	Discharge air temp is out of spec.	Check evaporator fan operation. Check electrical connections and input voltage.
		Fans are installed backwards. Check airflow direction.
		Fan blades are installed incorrectly. Make sure fan blades have correct pitch and are per specification.
		Check to see that fan plenum is installed correctly. It should not have any gaps.
	Check suction pressure and insure that it meets factory specifications.	
	Case is in defrost.	Check defrost settings. See Technical Specifications section.
	Product load may be over its limits blocking airflow.	Redistribute product so it does not exceed load level. There is a sticker on the inside of the case indicating what the maximum load line is.
Coil is freezing over.	Return air is blocked, make sure debris is not blocking the intake section.	
	Coil close-offs are not installed. Inspect coil to make sure these parts are on the case.	
Condensing coil or evaporator coil is clogged or dirty.	Clean coil.	
<b>Case temperature is too cold.</b>	The t-stat temp is set too low.	Check settings. See Technical Specifications section.
	Ambient conditions may be affecting the case operation.	Check case position in store. Is the case located near an open door, window, electric fan or air conditioning vent that may cause air currents? See page 5 for details. Provide shading for the case or move out of direct sunlight. Move the case away from or block air ventilation currents aimed directly at the case. Case must be located minimum 15 Ft away from doors or windows. Cases are designed to operate at 55% Relative humidity and a temperature of 75°F.
<b>Condensation on glass.</b>	Ambient conditions may be affecting the case operation.	Check case position in store. Is the case located near an open door, window, electric fan or air conditioning vent that may cause air currents? Case must be located minimum 15 Ft away from doors or windows. Cases are designed to operate at 55% Relative humidity and a temperature of 75°F.
	Inadequate air circulation.	Check if air sweep fans are functioning, check electrical connections.
	There is not enough heat provided in the airflow.	Check if air sweep heater is functioning, check electrical connections.
	There are glass gaps on the side of the case.	See glass adjustment section.
	Glass is not completely shut.	Close glass correctly.

## Troubleshooting

Problem	Possible Cause	Possible Solution
<b>Water has pooled under case.</b>	Case drain is clogged.	Clear drain.
	PVC drains under case may have a leak.	Repair as needed.
	Case tub has unsealed opening.	Seal as needed.
	If the case is in a line-up, case to case joint is missing or unsealed.	Install case to case joint and seal as needed.
	Evaporator pan is overflowing (if applicable).	Check electrical connection to evaporator pan. Check float assembly, it should move freely up and down the support stem. Clear any debris.
<b>Case is not draining properly.</b>	Case is not level.	Level the case.
	Drain screen is plugged.	Clean drain screen and remove any debris.
	Drain or P-trap is clogged.	Clear any debris.
<b>Frost or ice on evaporator coil.</b>	Evaporator fans are not functioning.	Check electrical connections.
	Defrost clock is not functioning.	Case should be serviced by a qualified service technician.
	Coil is freezing over.	Return air is blocked, make sure debris is not blocking the intake section.
		Coil close-offs are not installed. Inspect coil to make sure these parts are on the case.
<b>Lights do not come on.</b>	LED Driver/light socket wiring.	Check electrical connections. See Electrical Section and check wiring diagram.
	LED Driver needs to be replaced.	Case should be serviced by a qualified service technician. See Electrical Section.
	Lamp socket needs to be replaced.	Case should be serviced by a qualified service technician.
	Lamp needs to be replaced.	See Maintenance Section.
	Light Switch needs to be replaced.	Case should be serviced by a qualified service technician.

## Appendix A. - Temperature Guidelines

The refrigerators should be operated according to the manufacturer's published engineering specifications for entering air temperatures for specific equipment applications. Table 1 shows the typical temperature of the air entering the food zone one hour before the start of defrost and one hour after defrost for various categories of refrigerators. Refer to Appendix C for Field Evaluation Guidelines.

Type of Refrigerator	Typical Entering Air Temperature
<b>I. OPEN DISPLAY</b>	
A. Non frozen:	
1) Meat	28°F
2) Dairy/Deli	32°F
3) Produce	
a. Processed	36°F
b. Unprocessed	45°F
B. Frozen	0°F
C. Ice Cream	-5°F
<b>II. CLOSED DISPLAY</b>	
A. Non frozen:	
1) Meat	34°F
2) Dairy/Deli	34°F
3) Produce	
a. Processed	36°F
b. Unprocessed	45°F
B. Frozen	0°F
C. Ice Cream	-5°F

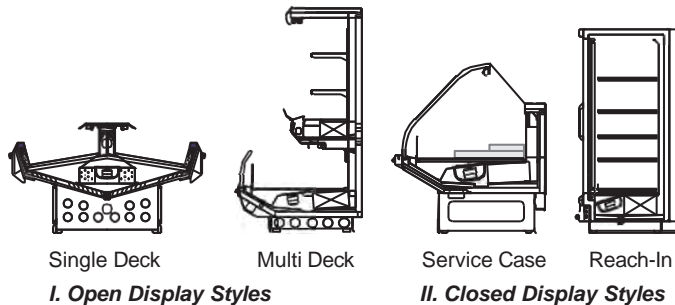

## Appendix B. - Application Recommendations

1. Temperature performance is critical for controlling bacteria growth. Therefore, the following recommendations are included in the standard. They are based on confirmed field experience over many years.
2. The installer is responsible for following the installation instructions and recommendations provided by Hussmann for the installation of each individual type refrigerator.
3. Refrigeration piping should be sized according to the equipment manufacturer's recommendations and installed in accordance with normal refrigeration practices. Refrigeration piping should be insulated according to Hussmann's recommendations.

3. A clogged waste outlet blocks refrigeration. The installer is responsible for the proper installation of the system which dispenses condensate waste through an air gap into the building indirect waste system.
4. The installer should perform a complete start-up evaluation prior to the loading of food into the refrigerator, which includes such items as:
  - a) Initial temperature performance, Coils should be properly fed with a refrigerant according to manufacturer's recommendations.
  - b) Observation of outside influences such as drafts, radiant heating from the ceiling and from lamps. Such influence should be properly corrected or compensated for.
  - c) At the same time, checks should be made of the store dry-bulb and wet-bulb temperatures to ascertain that they are within the limits prescribed by Hussmann.
  - d) Complete start-up procedures should include checking through a defrost to make certain of its adequate frequency and length without substantially exceeding the actual needs. This should include checking the electrical or refrigerant circuits to make sure that defrosts are correctly programmed for all the refrigerators connected to each refrigeration system.
  - e) Recording instruments should be used to check performance.

## Appendix C. - Field Recommendations

Recommendations for field evaluating the performance of retail food refrigerators and hot cases

- 1.0 The most consistent indicator of display refrigerator performance is temperature of the air entering the product zone (see Appendix A). In practical use, the precise determination of return air temperature is extremely difficult. Readings of return air temperatures will be variable and results will be inconsistent. The product temperature alone is not an indicator of refrigerator performance.

**NOTE:** Public Health will use the temperature of the product in determining if the refrigerator will be allowed to display potentially hazardous food. For the purpose of this evaluation, product temperature above the FDA Food Code 1993 temperature for potentially hazardous food will be the first indication that an evaluation should be performed. It is expected that all refrigerators will keep food at the FDA Food Code 1993 temperature for potentially hazardous food.

- 1.1 The following recommendations are made for the purpose of arriving at easily taken and understood data which, coupled with other observations, may be used to determine whether a display refrigerator is working as intended:
- a) **INSTRUMENT** - A stainless steel stem-type thermometer is recommended and it should have a dial a minimum of 1 inch internal diameter. A test thermometer scaled only in Celsius or dually scaled in Celsius and Fahrenheit shall be accurate to 1°C (1.8°F). Temperature measuring devices that are scaled only in Fahrenheit shall be accurate to 2°F. The thermometer should be checked for proper calibration. (It should read 32°F when the stem is immersed in an ice water bath).
  - b) **LOCATION** - The probe or sensing element of the thermometer should be located in the airstream where the air first enters the display or storage area, and not more than 1 inch away from the surface and in the center of the discharge opening.
  - c) **READING** - It should first be determined that the refrigerator is refrigerating and has operated at least one hour since the end of the last defrost period. The thermometer reading should be made only after it has been allowed to stabilize, i.e., maintain a constant reading.
  - d) **OTHER OBSERVATIONS** - Other observations should be made which may indicate operating problems, such as unsatisfactory product, feel/appearance.
  - e) **CONCLUSIONS** - In the absence of any apparent undesirable conditions, the refrigerator should be judged to be operating properly. If it is determined that such condition is undesirable, i.e., the product is above proper temperature, checks should be made for the following:
    1. Has the refrigerator been loaded with warm product?
    2. Is the product loaded beyond the "Safe Load Line" markers?
    3. Are the return air ducts blocked?
    4. Are the entering air ducts blocked?
    5. Is a dumped display causing turbulent air flow and mixing with room air?
    6. Are spotlights or other high intensity lighting directed onto the product?
    7. Are there unusual draft conditions (from heating/air-conditioning ducts, open doors, etc.)?
    8. Is there exposure to direct sunlight?
    9. Are display signs blocking or diverting airflow?

10. Are the coils of the refrigerator iced up?
11. Is the store ambient over 75°F, 55% RH as set forth in ASHRAE Standard 72 and ASHRAE Standard 117?
12. Are the shelf positions, number, and size other than recommended by Hussmann?
13. Is there an improper application or control system?
14. Is the evaporator fan motor/blade inoperative?
15. Is the defrost time excessive?
16. Is the defrost termination, thermostat (if used) set too high?
17. Are the refrigerant controls incorrectly adjusted?
18. Is the air entering the condenser above design conditions? Are the condenser fins clear of dirt, dust, etc.?
19. Is there a shortage of refrigerant?
20. Has the equipment been modified to use replacements for CFC-12, CFC-502 or other refrigerant? If so, have the modifications been made in accordance with the recommendations of the equipment manufacturer? Is the refrigerator charged with the proper refrigerant and lubricant? Does the system use the recommended compressor?

## Appendix D. - Recommendations to User

- 1.0 Hussmann Corporation provides instructions and recommendations for proper periodic cleaning. The user will be responsible for such cleaning, including the cleaning of low temperature equipment within the compartment and the cooling coil area(s). Cleaning practices, particularly with respect to proper refrigerator unloading and warm-up, must be in accordance with applicable recommendations.
1. Cleaning of non frozen food equipment should include a weekly cleaning of the food compartment as a minimum to prevent bacteria growth from accumulating. Actual use and products may dictate more frequent cleaning. Circumstances of use and equipment design must also dictate the frequency of cleaning the display areas. Weekly washing down of the storage compartment is also recommended, especially for equipment subject to drippage of milk or other liquids, or the collection of vegetable, meat, crumbs, etc. or other debris or litter. Daily cleaning of the external areas surrounding the storage or display compartments with detergent and water will keep the equipment presentable and prevent grime buildup.
  2. Load levels as defined by the manufacturer must be observed.

1.3 The best preservation is achieved by following these rules:

- a) Buy quality products.
- b) Receive perishables from transit equipment at the ideal temperature for the particular product.
- c) Expedite perishables to the store's storage equipment to avoid unnecessary warm-up and prolonged temperature recovery. Food store refrigerators are not food chillers nor can they reclaim quality lost through previous mishandling.
- d) Care must be taken when cross merchandising products to ensure that potentially hazardous vegetable products are not placed in non refrigerated areas.
- e) Display and storage equipment doors should be kept closed during periods of inactivity.
- f) Minimize the transfer time of perishables from storage to display.
- g) Keep meat under refrigeration in meat cutting and processing area except for the few moments it is being handled in processing. When a cut or tray of meat is not to be worked on immediately, the procedure should call for returning it to refrigeration.
- h) Keep tools clean and sanitized. Since mechanical equipment is used for fresh meat processing, all such equipment should be cleaned at least daily and each time a different kind of meat product comes in contact with the tool or equipment.
- i) Make sure that all refrigeration equipment is installed and adjusted in strict accordance with the manufacturer's recommendations.
- j) See that all storage and refrigeration equipment is kept in proper working order by routine maintenance.



---

This warning does not mean that Hussmann products will cause cancer or reproductive harm, or is in violation of any product-safety standards or requirements. As clarified by the California State government, Proposition 65 can be considered more of a ‘right to know’ law than a pure product safety law. When used as designed, Hussmann believes that our products are not harmful. We provide the Proposition 65 warning to stay in compliance with California State law. It is your responsibility to provide accurate Proposition 65 warning labels to your customers when necessary. For more information on Proposition 65, please visit the California State government website.

---

### Service Record

Last service date:      By:

_____	_____
_____	_____
_____	_____
_____	_____
_____	_____
_____	_____
_____	_____

---

## HUSSMANN®/Chino

Additional copies of this publication may be obtained by contacting:

Hussmann® Chino  
13770 Ramona Avenue • Chino, California 91710  
(909) 628-8942 FAX  
(909) 590-4910  
(800) 395-9229

[www.hussmann.com](http://www.hussmann.com)

The <i>MODEL NAME</i> and <i>SERIAL NUMBER</i> is required in order to provide you with the correct parts and information for your particular unit. They can be found on a small metal plate on the unit. Please note them below for future reference.
<b>MODEL:</b>
<b>SERIAL NUMBER:</b>