

HUSSMANN®

SMG8B & SSG8B

Medium Temperature
Self Contained

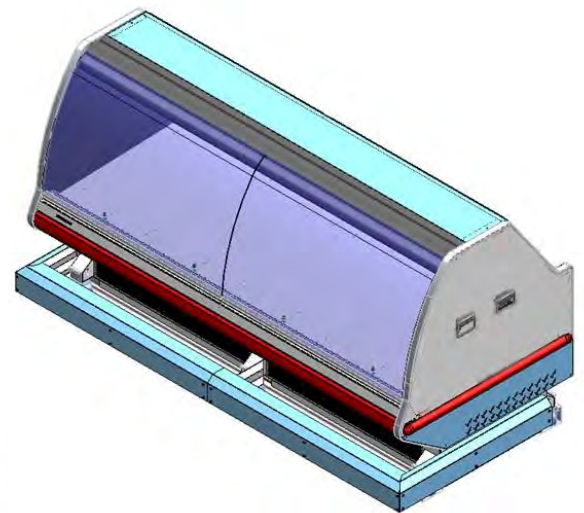
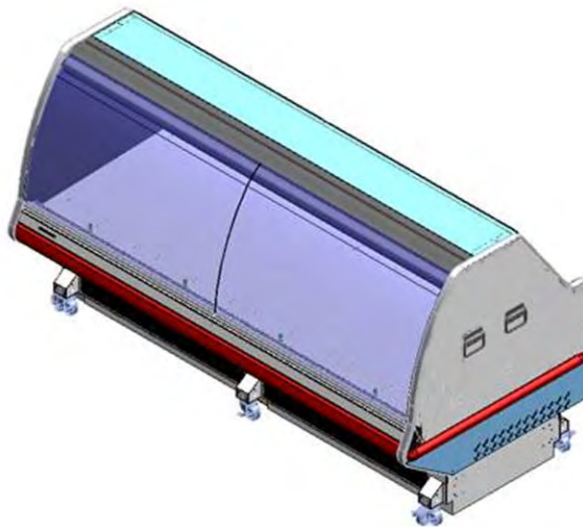

(Diamond tread bumper shown)

Installation & Operation Manual

IMPORTANT
Keep in store for
future reference!

P/N 3018126_E
AUGUST 2018

ATTENTION

Merchandiser must operate for 24 hours
before loading product!

Regularly check merchandiser temperatures.

Do not break the cold chain. Keep products
in cooler before loading into merchandiser.

These merchandisers are designed
for pre-chilled products only.



IMPORTANT
KEEP IN STORE FOR FUTURE REFERENCE
Quality that sets industry standards!

12999 St. Charles Rock Road • Bridgeton, MO 63044-2483

U.S. & Canada 1-800-922-1919 • Mexico 1-800-890-2900

www.hussmann.com

© 2018 Hussmann Corporation

TABLE OF CONTENTS

iii

INSTALLATION

UL Listing	1-1
Federal / State Regulation	1-1
Hussmann Product Control	1-1
Shipping Damage	1-1
Location	1-1
Self Contained (Location)	1-2
Unloading	1-3
Exterior Loading	1-3
Shipping Skid	1-3
Merchandiser Leveling	1-3
Serial Plate Location	1-4
Refrigeration Unit Access	1-4
Glass Positioning	1-5
Adjustment Bolt	1-6
Optional Display Pan, Wire Rack, and Divider Kit	1-9
Self-Contained Refrigeration Equipment Start Up Check List	1-10

ELECTRICAL / REFRIGERATION

Merchandiser Electrical Data	2-1
Field Wiring	2-1
Electrical Connections	2-1
Electrical Outlet (Optional)	2-1
Refrigeration (Self Contained Models)	2-1
Waste Outlet and Water Seal	2-2

START UP / OPERATION

Controller Operation	3-1
Controller Parameters	3-3
Dixell Control Sensor Location	3-6
Controls and Adjustments	3-7
TEV Adjustment	3-8
Self-Contained (Location)	3-8
Load Limits	3-9
Stocking	3-9

MAINTENANCE

Care and Cleaning	4-1
Removing Scratches from Bumper	4-2
Cleaning Under Fan Plenum	4-2
Cleaning Discharge Air Louvers	4-2
Cleaning Stainless Steel Surfaces	4-3
Cleaning Coils	4-3
Cleaning Optional Drain Pan	4-4
Self-Contained Refrigeration Equipment Maintenance Check List	4-5

SERVICE

Replacing Fan Motors and Blades	5-1
Replacing Cylinders — Single Pane Glass	5-2
Replacing Single Pane Front Glass	5-3
Replacing Glass Hand Grip	5-4

SAFE-NET III

Safe-NET III User Instructions	6-1
Display (Optional)	6-2
Start Up	6-2
Sequence of Operation Diagram	6-3
Alarms and Codes	6-4
Manual Defrost	6-4

WARRANTY

REVISION HISTORY

REVISION D - Added instruction for adjusting and replacing the glass panes. changed controller to Dixell XR75

REVISION C - Removed logo, Page 1-1.

REVISION B - Changed Drawing on Page 3-10. Updated Page 3-1 added Page 3-2, Updated Drawings on Page 3-7 Added Load Limit Drawing to Page 3-10

ORIGINAL ISSUE — DECEMBER 2016

ANSI Z535.5 DEFINITIONS



• **DANGER** – Indicate[s] a hazardous situation which, if not avoided, will result in death or serious injury.



• **WARNING** – Indicate[s] a hazardous situation which, if not avoided, could result in death or serious injury.



• **CAUTION** – Indicate[s] a hazardous situation which, if not avoided, could result in minor or moderate injury.

• **NOTICE** – *Not related to personal injury* – Indicates[s] situations, which if not avoided, could result in damage to equipment.



This warning does not mean that Husmann products will cause cancer or reproductive harm, or is in violation of any product-safety standards or requirements. As clarified by the California State government, Proposition 65 can be considered more of a ‘right to know’ law than a pure product safety law. When used as designed, Husmann believes that our products are not harmful. We provide the Proposition 65 warning to stay in compliance with California State law. It is your responsibility to provide accurate Proposition 65 warning labels to your customers when necessary. For more information on Proposition 65, please visit the California State government website.

INSTALLATION

UL LISTING

These merchandisers are manufactured to meet ANSI/ UL 471 standard requirements for safety. Proper installation is required to maintain the listing.

FEDERAL / STATE REGULATION

These merchandisers at the time they are manufactured, meet all federal and state/ provincial regulations. Proper installation is required to ensure these standards are maintained. Near the serial plate, each merchandiser carries a label identifying the environment for which the merchandiser was designed for use. A Type II fan speed control kit is required for each merchandiser to operate at Type II conditions.

ANSI/NSF-7 Type I – Display Refrigerator / Freezer
Intended for 75°F (24°C) / 55%RH Ambient Application

ANSI/NSF-7 Type II – Display Refrigerator / Freezer
Intended for 80°F / 55%RH Ambient Application

ANSI/NSF-7 – Display Refrigerator
Intended for Bulk Produce

HUSSMANN PRODUCT CONTROL

The serial number and shipping date of all equipment is recorded in Hussmann's files for warranty and replacement part purposes. All correspondence pertaining to warranty or parts ordering must include the serial number of each piece of equipment involved. This is to ensure the customer is provided with the correct parts.

Recommended operating ambient temperature is between 65°F (18°C) to 75°F (23.9°C). Maximum relative humidity is 55%.

SHIPPING DAMAGE

All equipment should be thoroughly examined for shipping damage before and during unloading. This equipment has been carefully inspected at our factory. Any claim for loss or damage must be made to the carrier. The carrier will provide any necessary inspection reports and/or claim forms.

Apparent Loss or Damage

If there is an obvious loss or damage, it must be noted on the freight bill or express receipt and signed by the carrier's agent; otherwise, carrier may refuse claim.

Concealed Loss or Damage

When loss or damage is not apparent until after equipment is uncrated, retain all packing materials and submit a written response to the carrier for inspection within 15 days.

LOCATION

These merchandisers are designed for displaying products in air conditioned stores where temperature is maintained at or below the ANSI / NSF-7 specified level and relative humidity is maintained at or below 55%.

Placing refrigerated merchandisers in direct sunlight, near hot tables or near other heat sources could impair their efficiency. Like other merchandisers, these merchandisers are sensitive to air disturbances. Air currents passing around merchandisers will seriously impair their operation. Do NOT allow air conditioning, electric fans, open doors or windows, etc. to create air currents around the merchandiser.

1-2 INSTALLATION

SELF CONTAINED (LOCATION)

Product should always be maintained at proper temperature. This means that from the time the product is received, through storage, preparation and display, the temperature of the product must be controlled to maximize the life of the product.

BE SURE TO POSITION SELF CONTAINED MERCHANDISERS PROPERLY.

SELF CONTAINED models have vented base panels to allow air circulation through the condensing unit. Allow for a minimum 4 in. clearance from walls, merchandisers, and any other large objects near the merchandiser's vented base panels (for self contained models). Blocking or restricting air flow will adversely affect performance and may damage the refrigeration system.



This warning does not mean that Hussmann products will cause cancer or reproductive harm, or is in violation of any product-safety standards or requirements. As clarified by the California State government, Proposition 65 can be considered more of a 'right to know' law than a pure product safety law. When used as designed, Hussmann believes that our products are not harmful. We provide the Proposition 65 warning to stay in compliance with California State law. It is your responsibility to provide accurate Proposition 65 warning labels to your customers when necessary. For more information on Proposition 65, please visit the California State government website.

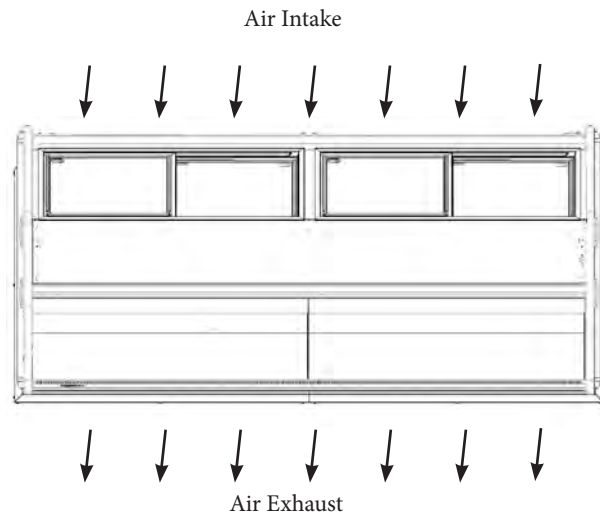
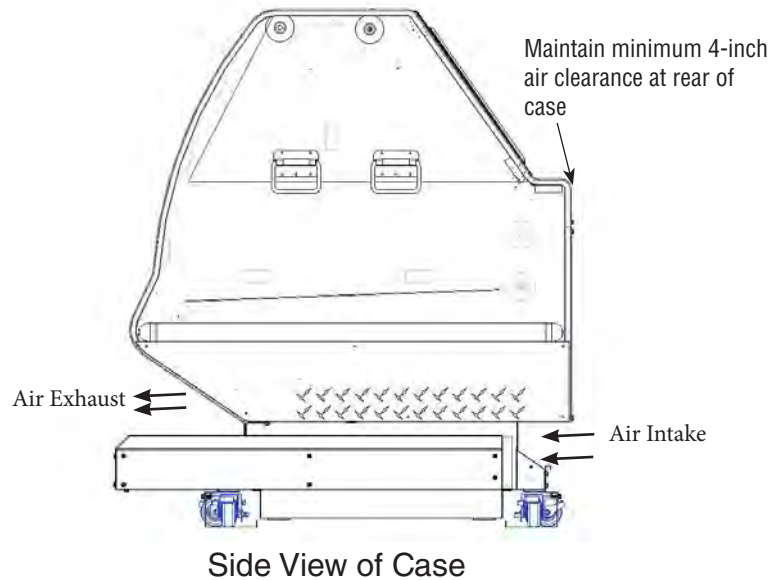

UNLOADING

Unloading from Trailer:

Lever Bar (also known as a Mule, Johnson Bar, J-bar, Lever Dolly, or Pry Lever)

Move the merchandiser as close as possible to its permanent location and remove all packaging. Check for damage before discarding packaging. Remove all separately packed accessories such as kits and shelves.

Improper handling may cause damage to the merchandiser when unloading. To avoid damage:

1. Do not drag the merchandiser out of the trailer. Use a Johnson bar (mule).
2. Use a forklift or dolly to remove the merchandiser from the trailer.

EXTERIOR LOADING

Do NOT walk on top of merchandisers or damage to the merchandisers and serious personal injury could occur.

MERCHANDISERS ARE NOT STRUCTURALLY DESIGNED TO SUPPORT EXTERNAL LOADING such as the weight of a person. Do not place heavy objects on the merchandiser.

SHIPPING SKID

Each merchandiser is shipped on a skid to protect the merchandiser's base and to make positioning the case easier.

Unscrew the case from the skid. The fixture can now be lifted off the crate skid. **Lift only at base of skid!** Remove any braces and/or skids attached.

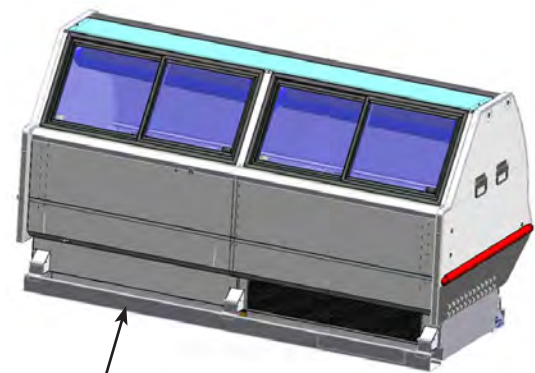

Shipping Brace

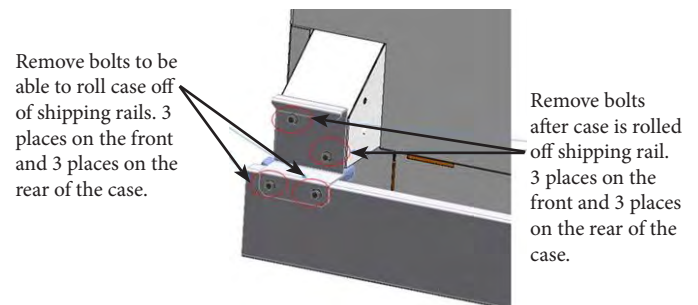

Remove bolts to be able to roll case off of shipping rails. 3 places on the front and 3 places on the rear of the case.

Remove bolts after case is rolled off shipping rail. 3 places on the front and 3 places on the rear of the case.

WARNING

Do NOT stand or walk on top of merchandiser. Do not store items or flammable materials atop the unit.

DO NOT LAY MERCHANDISER OVER ON THE FLOOR TO REMOVE SKID.

Check floor where cases are to be set to see if it is a level area. Determine the highest part of the floor.

MERCHANDISER LEVELING

BE SURE TO POSITION MERCHANDISERS PROPERLY. Level the merchandiser by all four corners. Merchandiser(s) must be installed level to ensure proper operation of the refrigeration system, and to ensure proper drainage of defrost water.

1-4 INSTALLATION

SERIAL PLATE LOCATION

The serial plate is located on the back of the case on the left-hand side. The serial plate contains information specific to the case as well as a QR code that allows you to view replacement parts and data sheets on a smart phone.

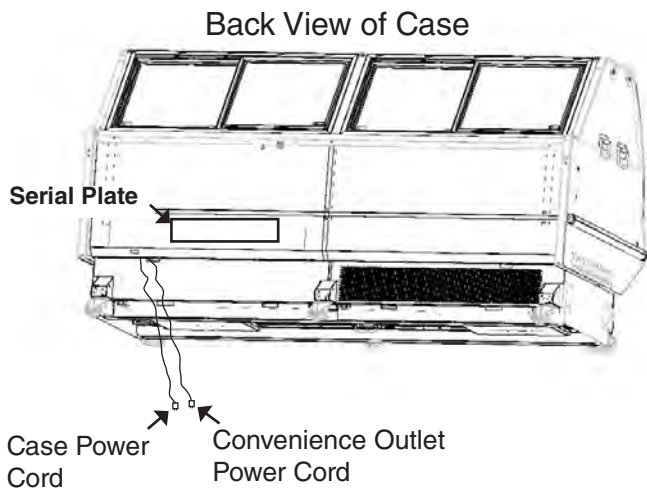

REFRIGERATION UNIT ACCESS

Panels on the front and rear of the case may be removed by lifting the panel straight upward to clear lower brackets, and then down to remove. The panel is installed by reversing the above procedure. Ensure all panels are installed to prevent air circulation problems.

The case is shipped with the the front left panel removed, and the two lower back panels removed. These panels must be installed during installation.

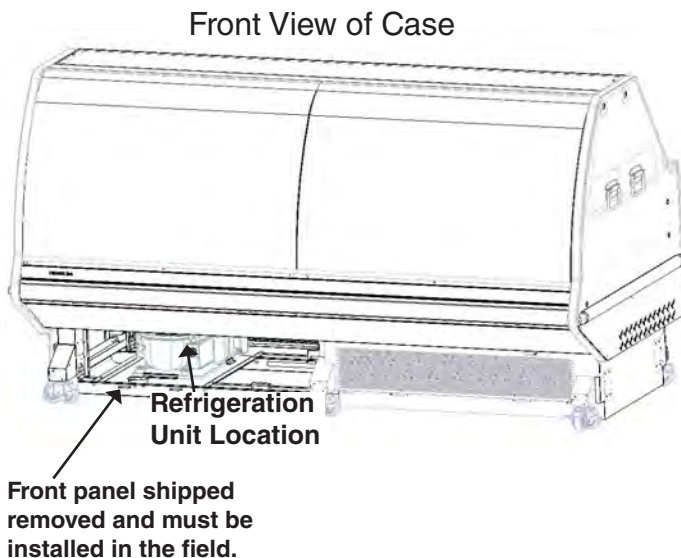
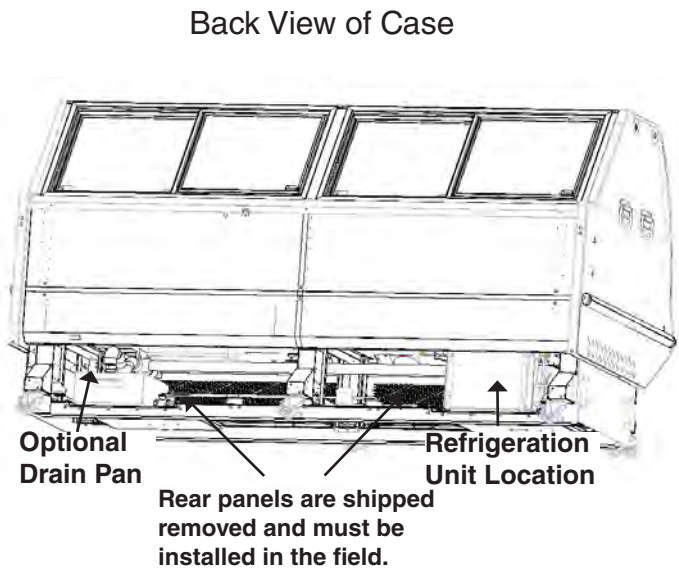

GLASS POSITIONING

Check the following to improve opening or closing of the merchandiser front glass.

1. Has the merchandiser been leveled according to preceding paragraphs?
2. Is the glass handle installed correctly?

Verify the glass is bottomed out the length of the handle. A bowed handle indicates the glass may not be bottomed out at the center of the handle.

The handle must be removed before it can be repositioned. The handle is held in place with silicone which must be completely removed from the handle and the glass. Remove the handle by pulling it away from the glass (do not use tools to pry this loose). A damaged or bent handle must be replaced. Apply new silicone into the handle and firmly press onto the glass.

3. Is the glass seated in the clamp hardware correctly?

Verify glass is bottomed out in clamp hardware. If the glass is not bottomed out in the clamp hardware it can be re-positioned as follows:



- A. Remove the glass and clamp hardware from the merchandiser by opening the glass and loosening set screws in hinge (Metric 3 millimeter set screws).
- B. Slide the glass and clamp hardware to the side out of the hinges and lay them on an appropriate work surface.
Note: Adjacent glass must be closed.
- C. Loosen the 8 set screws on the underside of the clamp hardware.
- D. Push the clamp hardware onto the glass until bottomed out.
- E. The clamp hardware must overhang the glass by an equal amount on each side.
- F. Tighten set-screws and re-install on merchandiser. Apply a drop of Loctite 242 or equivalent thread locking fluid onto each set screw of the glass clamp assembly. Tighten all screws with a TORX T15 bit and re-install onto merchandiser.

IMPORTANT: Tighten all glass clamp set screws to 26 inch lbs. Verify bit is in good condition and not worn out. When set screws are tightened, glass is firmly held in place by glass clamps.

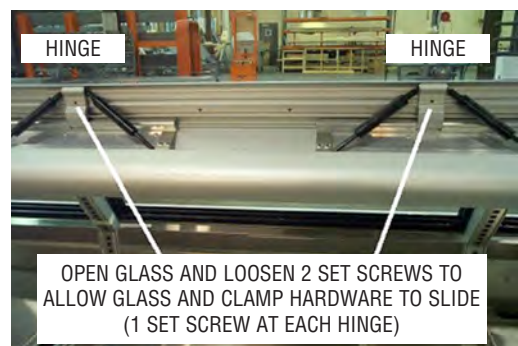

1-6 INSTALLATION

4. Is the glass hitting the end or adjacent glass? Slowly open and close the glass to inspect. If the glass is hitting the end or adjacent glass it may not be positioned correctly from left to right. This can be adjusted as follows:

- Loosen the 2 screws holding the hinge to the clamp hardware (Metric 3 millimeter screws).



- Slide the clamp hardware to either side as needed.
- Tighten the screws and check glass for proper operation.

5. Is the glass still hitting adjacent glass? Slowly open and close the glass to inspect.

Optional Flexible Wiper Gasket

There may be an optional flexible wiper gasket that is attached to each side. These are designed to overlap each other, sealing the gap between the glass and allowing side-to-side glass adjustment. After all glass has been adjusted as defined in Step 4, the flexible portion of one gasket at a joint may be trimmed with a razor knife. Be sure that the remaining wiper gasket seals the gap. Verify proper operation.

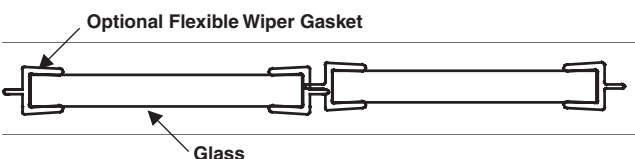

ADJUSTMENT BOLT

If the glass still does not open or close correctly, adjustment of the top frame may be necessary.

This merchandiser is equipped with an adjustment bolt at the top rear of the merchandiser to raise or lower the glass. This allows for improvements in the glass operation and sealing. The following outlines how to access the adjustment bolt. The top must be free to move as the adjustment bolt is turned.



1. Loosen joining or end bolts at top of merchandiser, (2 at each end of merchandiser).
2. If caulk or silicone has been applied between merchandiser joints or ends in the top area it must be removed.
3. Remove rear doors.

- Remove screws at top of rear door frame. The bottom screws do not need to be removed.

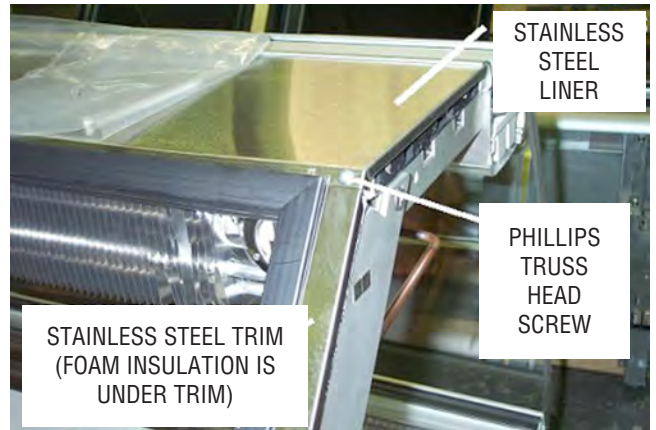

- Pull back the top of the door frame approximately 2 inches. This will allow clearance for removal of the stainless steel top liner and trim pieces.

- Remove stainless steel trim pieces and foam insulation on each side of the door frame.



- Some models have a Phillips truss head screw holding the stainless steel liner to the trim. These screws are visible from the rear of the merchandiser to the side of the door frame. These must be removed.

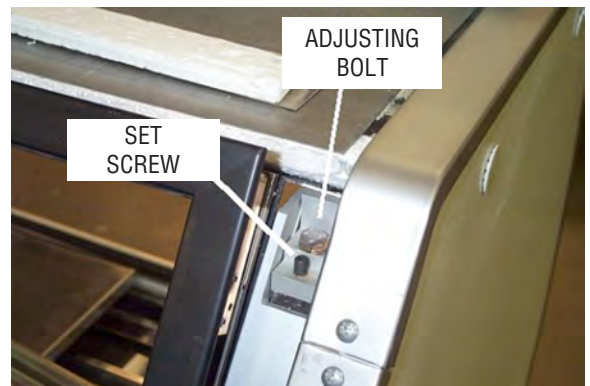

- Remove stainless steel top liner by grabbing the rear flange and pulling back. Note: It is possible to access the adjusting bolt by using a small swivel socket without removing the stainless top liner. To do this, the stainless steel trim and foam noted in Step 8 must be removed.

1-8 INSTALLATION

9. The set screw and adjusting bolt are now accessible.

11. Re-apply caulk or silicone as required.

12. Verify glass is positioned and operating correctly.

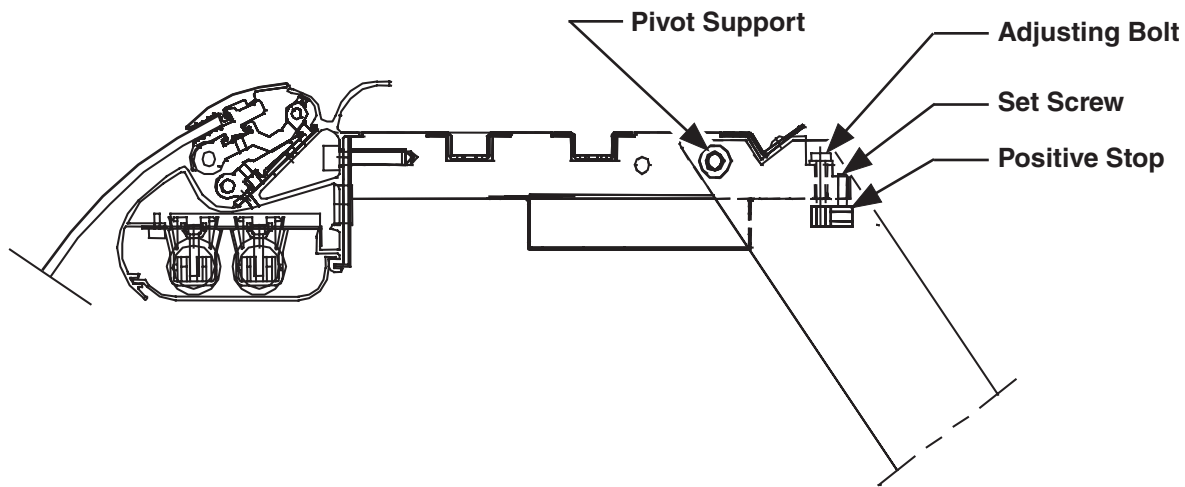

- The set screw must be backed out before turning the adjusting bolt ($\frac{1}{8}$ inch set screw). The set screw serves as a positive stop.
- The adjusting bolt should be turned no more than a half-turn before inspecting glass position and operation.
- Turning the adjusting bolt clockwise will raise the front glass.
- Turning the adjusting bolt counter-clockwise will lower the front glass.
- Once the glass position is set, tighten the set screw (positive stop).

10. Once glass is positioned and operating correctly, re-install components and hardware removed.

Note: The door frame is designed to have a tight fit. A putty knife between the top of the frame and the insulated panel will help guide it into position.

OPTIONAL DISPLAY PAN, WIRE RACK, AND DIVIDER KIT

The wire shelf with divider fits in the case. The divider slides from one end to the other separating meat and seafood products.

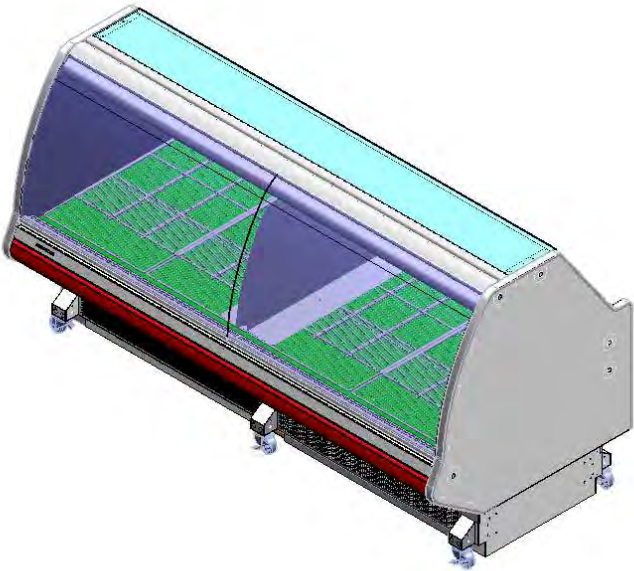

Divider Proper Orientation on SSG

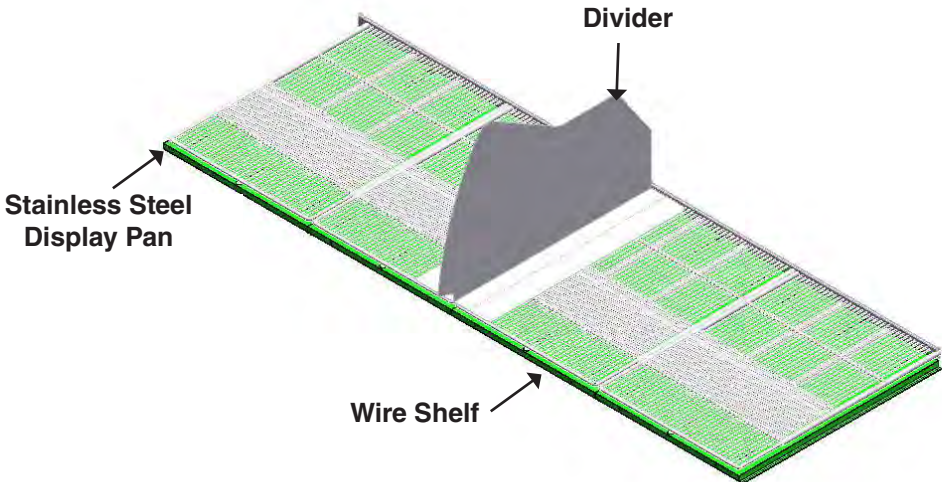

Hussmann Self-Contained Refrigeration Equipment Start Up Check List

Please note that failure to follow this start-up document may void your factory warranty

Step	Startup Activity	Check
1	Locate, read and maintain install/operation manual in a safe place for future reference.	<input type="checkbox"/>
2	Examine unit. Confirm there is NO damage or concealed damage.	<input type="checkbox"/>
3	Level the unit, side to side and front to rear.	<input type="checkbox"/>
4	Remove all shipping brackets/compressor straps/bolts etc.	<input type="checkbox"/>
5	Unit must be run on a dedicated electrical circuit without the use of an extension cord.	<input type="checkbox"/>
6	Ensure that the proper electrical requirements for the equipment are supplied.	<input type="checkbox"/>
7	Verify field electrical connections are tight.	<input type="checkbox"/>
8	Verify all electrical wiring is secured and clear of any sharp edges or hot lines.	<input type="checkbox"/>
9	Verify the condensate drain line is properly trapped and pitched.	<input type="checkbox"/>
10	Verify all required clearances on the sides and back of unit.	<input type="checkbox"/>
11	Verify there are no air disturbances external to the unit. Heat and air registers, fans, and doors etc.	<input type="checkbox"/>
Advise owner/operator that merchandiser must operate at temperature for 24 hrs prior to loading with product.		

Form HSCW01 Rev. 30MAY12 P/N 0525209_B

LEGAL DISCLAIMER:

Hussmann shall not be liable for any repair or replacements made without the written consent of Hussmann, or when the product is installed or operated in a manner contrary to the printed instructions covering installation and service which accompanied such product.

ELECTRICAL / REFRIGERATION

MERCHANDISER ELECTRICAL DATA

Refer to the technical data sheets and merchandiser serial plate for electrical information.

FIELD WIRING

Field wiring must be sized for component amperes stamped on the serial plate. Actual ampere draw may be less than specified.

**ALWAYS CHECK THE SERIAL PLATE FOR
COMPONENT AMPERES**

ELECTRICAL CONNECTIONS

All wiring must be in compliance with NEC and local codes.

ELECTRICAL OUTLET (OPTIONAL)

Before the merchandiser is connected to any wall circuit, use a voltmeter to check that the outlet is at 100% of the rated voltage. The wall circuit must be dedicated for the merchandiser. Failure to do so voids the warranty. Do not use an extension cord. Never plug in more than one merchandiser per electrical circuit.

- Always use a dedicated circuit with the amperage stated on the unit.
- Plug into an outlet designed for the plug.
- Do not overload the circuit
- Do not use long or thin extension cords. Never use adapters.
- If in doubt, call an electrician.

Self-contained models have factory-installed power cords attached at the electrical box. There are two power cords at the rear of the case. One cord is for case power, and the power cord is for the convenience outlet power. Each cord must be on a separate circuit.

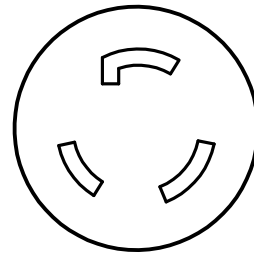

NEMA L5-20P PLUG
20A 125V UL/CSA

REFRIGERATION (Self Contained Models)

Each self contained model is equipped with its own condensing unit and control panel located beneath the display area. The correct type of refrigerant will be stamped on each merchandiser's serial plate. The merchandiser refrigeration piping is leak tested. The unit is charged with refrigerant, and shipped from the factory with all service valves open.

WATER OUTLET AND WATER SEAL

The condensate water outlet is factory installed on the case.

For cases equipped with a drain pan, this water seal drains into the pan located beneath the merchandiser.

NOTE: All lower base panels must be in place when the refrigerator is operating.



CAUTION

Risk of Electric Shock. If cord or plug becomes damaged, replace only with a cord and plug of the same type.



WARNING

Product will be degraded and may spoil if allowed to sit in a non-refrigerated area.



WARNING

Refrigeration lines are under pressure. Refrigerant must be recovered before attempting any connection or repair.



WARNING

— LOCK OUT / TAG OUT —

To avoid serious injury or death from electrical shock, always disconnect the electrical power at the main disconnect when servicing or replacing any electrical component. This includes, but is not limited to, such items as doors, lights, fans, heaters, and thermostats.







WARNING



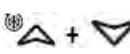

Merchandiser must be grounded. Do not remove the power supply cord ground.

START UP / OPERATION







CONTROLLER OPERATION

Follow the tables to use the commands. The keypad display is located on the front of the merchandiser.

	Switches the device ON and OFF, if onF = oFF
	Switches the light ON and OFF, if oA1 = Lig
	Locks/Unlocks the keyboard
	To enter programming mode
	Returns to room temperature display

Key	Function
	Press to display target setpoint, to select a parameter in programming mode, or to confirm an operation
	Starts a manual defrost
	Press the UP arrow to see the MAX temperature, to browse the parameter codes in programming mode, or to increase the currently displayed temperature value.
	Press the DOWN arrow to see the MIN temperature, to browse the parameter codes in programming mode, or to decrease the currently displayed temperature value.

Follow the LED commands to operate and control the case's lighting.

LED	Mode	Function
	ON	Compressor enabled
	Flashing	Anti-short cycle delay enabled
	ON	Defrost enabled
	Flashing	Drip time in progress
	ON	Fans enabled
	Flashing	Fans delay after defrost in progress.
	ON	An alarm is occurring

All cases manufactured after August 2017, use the Dixell XR75 Controller. For cases manufactured before this date, refer to the Safe-NET III user instructions in Section 6 of this manual.

How to see the setpoint

1. Push and immediately release the SET key. The display will show the setpoint value.
2. Push and immediately release the SET key or wait for 5 seconds to display the present value again.

How to change the setpoint:

The controller is shipped from the factory with Frozen Food settings. To modify the temperature for Ice Cream application, follow these instructions:

1. Push and hold the SET key for more than 2 seconds to change the setpoint value.
2. The value of the setpoint will be displayed and the °C or °F LED starts blinking.
3. To change the setpoint value push the UP or DOWN arrows within 10 seconds.
4. To memorize the new setpoint value, push the SET key again or wait 10 seconds.

How to start a manual defrost:

Push and hold the DEF key for more than 2 seconds and a manual defrost will start.

How to lock the keyboard:

1. Keep the UP + DOWN arrow keys pressed for more than 3 seconds.
2. The **PoF** message will be displayed and the keyboard will be locked. At this point it will be possible to see the setpoint of the MAX or Min temperature stored only.
3. If a key is pressed for more than 3 seconds the **PoF** message will be displayed.



WARNING

The optional evaporator fan remains ON when the adjustment knob is in the OFF position.

How to unlock the keyboard:

Press the UP and DOWN arrow keys together for more than 3 seconds until the "Pon" message displays.

Alarms:

- P1 Discharge temperature probe failure
- P2 Defrost termination probe failure
- HA Max temperature alarm
- LA Min temperature alarm

How to set defrost start time

Defrost occurs 24 hours after startup, then will take place every 24 hours

See 3-6 for sensor location.

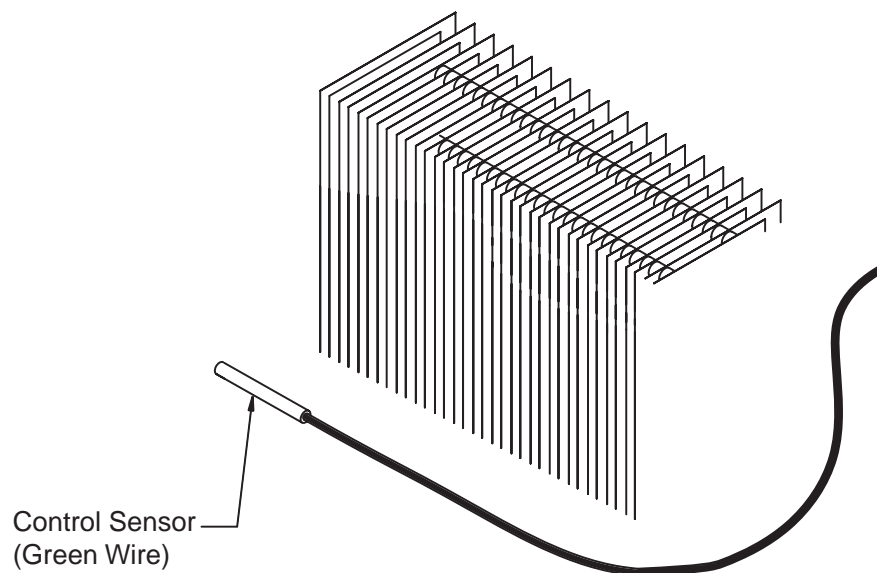
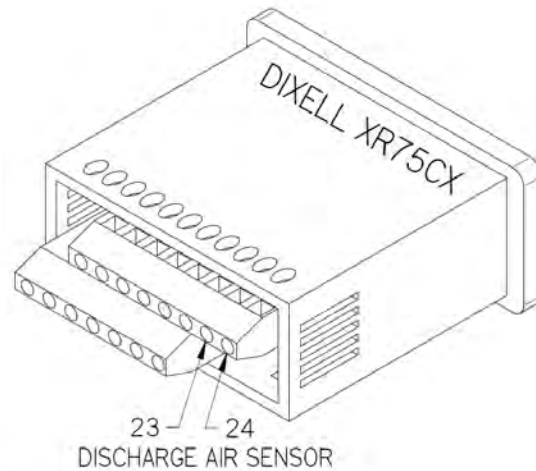

Controller Parameters

Dixell XR75					
XR 75 Code	XR 75 Parameter	XR 75 Function	XR 75 Default	SSG	SMG
SEt	Temperature Setpoint	LS to US	-5	17	19
REGULATION					
Hy	Differential	(0.1 to 25.5°C / 1 to 255°F) Intervention differential for setpoint. Compressor Cut IN is setpoint + differential (Hy). Compressor Cut OUT is when the temperature reaches the setpoint.	2	9	6
LS	Minimum setpoint	(-100°C to SEt/-148°F to SEt) Sets the minimum value for the setpoint.	-50	10	12
US	Maximum setpoint	(SEt to 110°C/ SEt to 230°F) Set the maximum value for the setpoint.	110	33	26
ot	Thermostat probe calibration	(-12.0 to 12.0°C; -120 to 120°F) Allows to adjust possible offset of the thermostat probe.	0	0	0
P2P	Evaporator probe presence	n = not present: the defrost stops by time y = present: the defrost stops by temperature	Y	n	n
oE	Evaporator probe calibration	(-12.0 to 12.0°C; -120 to 120°F) Allows to adjust possible offset of the evaporator probe.	0	0	0
P3P	Third probe presence (P3)	n = not present; the terminals 18-20 operate as digital input y = present; the terminals 18-20 operate as third probe	n	n	n
o3	Third probe calibration (P3)	(-12.0 to 12.0°C; -120 to 120°F) Allows to adjust possible offset of the third probe.	0	0	0
P4P	Fourth probe presence	(n = not present; y = present)	n	n	n
o4	Fourth probe calibration	(-12.0 to 12.0°C) Allows to adjust possible offset of the fourth probe.	0	0	0
Ods	Outputs activation delay at startup	(0 to 255 min) This function is enabled at the initial start up of the device and inhibits any output activation for the period of time set in the parameter.	0	0	0
Ac	Anti-short cycle delay	(0 to 50 min) Minimum interval between the compressor stop and the following restart.	1	2	2
rtr	Percentage of the second and first probe for regulation (0 to 100; 100 = P1, 0 = P2)	Allows to set the regulation according to the percentage of the first and second probe, as for the following formula $(rtr(P1-P2)/100 + P2)$.	100	100	100
CCt	Compressor ON time during continuous cycle	(0.0 to 24.0 hr; res. 10 min) Allows to set the length of the continuous cycle: compressor stays ON without interruption for the CCt time. Can be used, for instance, when the room is filled with new products.	0	0	0
CCS	Setpoint for continuous cycle	(-100 to 150°C) Sets the setpoint used during the continuous cycle.	-5	17	19
Con	Compressor ON time with faulty probe	(0 to 255 min) Time during which the compressor is active in case of faulty thermostat probe. With Con = 0, compressor is always OFF.	15	6	6
CoF	Compressor OFF time with faulty probe	(0 to 255 min) Time during which the compressor is OFF in case of faulty thermostat probe. When CoF = 0, compressor is always active.	30	2	2
CF	Temperature measurement unit	°C = Celsius, °F = Fahrenheit, (CAUTION! When the measurement unit is changed, the setpoint and the values of the parameters Hy, LS, US, ot, ALU and ALL have to be checked and modified if necessary).	C	F	F
rES	Resolution (for °C)	(in = 1°C; dE = 0.1°C) Allows decimal point display.	dE	dE	dE
Lod	Device display	(P1; P2, P3, P4, SEt, dtr) Selects which probe is displayed by the device: P1 = Thermostat probe P2 = Evaporator probe; P3 = Third probe (only for models with this option enabled), P4 = Fourth probe, SEt = setpoint, dtr = percentage of visualization	P1	P1	P1
Red	X- REP display (optional)	(P1; P2, P3, P4, SEt, dtr) Selects which probe is displayed by the device: P1 = Thermostat probe P2 = Evaporator probe; P3 = Third probe (only for models with this option enabled), P4 = Fourth probe, SEt = setpoint, dtr = percentage of visualization	P1	P1	P1
dLy	Display delay	(0 to 20.0 min; resul. 10 seconds) When the temperature increases, the display is updated of 1°C/1°F after this time.	0	0	0
dtr	Percentage of the second and first probe for visualization when Lod = dtr (0 to 100; 100 = P1, 0 = P2)	If Lod = dtr, it allows to set the visualization according to the percentage of the first and second probe, as for the following formula $(dtr(P1-P2)/100 + P2)$.	50	100	100

Controller Parameters

DEFROST					
EdF	Defrost mode (only for controller with RTC)	rtC = Real Time Clock mode. Defrost time follows Ld1 to Ld6 parameters on workdays and Sd1 to Sd6 on holidays. in = interval mode. The defrost starts when the time IdF is expired.	rtC	in	in
tdF	Defrost type	EL = electrical heater in = hot gas	EL	EL	EL
dFP	Probe selection for defrost termination	nP = no probe P1 = thermostat probe P2 = evaporator probe P3 = configurable probe P4 = probe on Hot Key plug	P2	P1	P1
dtE	Defrost termination temperature	(-50 to 50°C/ -58 to 122°F) (Enabled only when EdF = Pb) Sets the temperature measured by the evaporator probe, which causes the end of defrost.	8	48	48
IdF	Interval between defrost cycles	(0 to 120 hr) Determines the time interval between the beginning of two defrost cycles.	6	24	24
MdF	(Maximum) length for defrost	(0 to 255 min) When P2P = n, (not evaporator probe: timed defrost) it sets the defrost duration, when P2P = y (defrost end based on temperature) it sets the maximum length for defrost.	30	90	90
dSd	Start defrost delay	(0 to 99 min) This is useful when different defrost start times are necessary to avoid overloading the plant.	0	0	0
dFd	Temperature displayed during defrost	(rt = real temperature; it = temperature at defrost start; SET = setpoint; dEF = dEF la-bel)	it	Def	Def
dAd	MAX display delay after de-frost	(0 to 255 min)Sets the maximum time between the end of defrost and the restarting of the real roomtemperature display.	30	30	30
Fdt	Drip time	(0 to 120 min)Time interval between reaching defrost termination temperature and the restoring of thecontrollers normal operation. This time allows the evaporator to eliminate water drops that might have formed due to defrost.	0	0	0
dPo	First defrost after start-up	(y = immediately; n = after the IdF time)	n	y	y
dAF	Defrost delay after continuouscycle	(0 to 23.5 hr)Time interval between the end of the fast freezing cycle and the following defrost relatedto it.	0	0	0
FANS					
FnC	Fans operating mode	C-n = runs with the compressor, OFF during defrost O-n = continuous mode, OFF during defrost C-y = runs with the compressor, ON during defrost O-y = continuous mode, ON during defrost	O-n	O-y	O-y
Fnd	Fans delay after defrost	(0 to 255 min) Interval between end of defrost and evaporator fans start (0 to 59°C; Fct = 0 function disabled) If the difference in temperature between the evaporator and the room probes is morethan the value of the Fct parameter, the fans are switched ON.	10	0	0
Fct	Temperature differential avoiding short cycles of fans	(-50 to 50°C/ 122°F) Setting of temperature, detected by the evaporator probe, above which fans are always OFF.	10	0	0
FSt	Fans stop temperature	(0 to 15 min) With Fnc=C_n or C_y, (fan activated in parallel with compressor). Sets the evaporator fan ON cycling time when the compressor is OFF. When Fon=0 and FoF not equal to 0, the fans are always OFF, with Fon=0 and FoF=0, the fans are always OFF.	0	0	0
Fon	Fan ON time	(0 to 15 min)With Fnc=C_n or C_y, (fan activated in parallel with compressor). Sets the evaporator fan OFF cycling time when the compressor is OFF. When Fon=0 and FoF not equal to 0, the fans are always OFF, when Fon=0 and FoF=0, the fans are always OFF.	0	0	0
FoF	Fan OFF time	(0 to 15 min)With Fnc=C_n or C_y, (fan activated in parallel with compressor). Sets the evaporator fan OFF cycling time when the compressor is OFF. When Fon=0 and FoF not equal to 0, the fans are always OFF, when Fon=0 and FoF=0, the fans are always OFF.	0	0	0
FAP	Probe selection for fan management	nP = no probe P1 = thermostat probe P2 = evaporator probe P3 = configurable probe P4 = probe on Hot Key plug	P2	nP	nP
AUXILIARY THERMOSTAT CONFIGURATION (terms. 1-4) - oA3 = AUS					
ACH	Kind of regulation for auxiliary relay	Ht = heating CL = cooling	CL	CL	CL
SAA	Setpoint for auxiliary relay	(-100 to 150.0°C; -148 to 302°F) Defines the room temperature setpoint to switch auxiliary relay.	0	0	0
SHy	Differential for auxiliary output	(0.1 to 25.5°C/ 1 to 255°F)Intervention differential for auxiliary output setpoint. When ACH = CL, AUX Cut in is SAA + SHy; AUX Cut out is SAA When ACH = Ht, AUX Cut in is SAA - SHy; AUX Cut out is SAA	2	2	2
ArP	Probe selection for auxiliary	nP = no probe, the auxiliary relay is switched only by the digital input P1 = Probe 1 (thermostat probe) P2 = Probe 2 (evaporator probe) P3 = Probe 3 (display probe) P4 = Probe 4	nP	nP	nP
Sdd	Auxiliary relay OFF during defrost	n = the auxiliary relay operates during defrost y = the auxiliary relay is switched OFF during defrost	n	n	n
ALARMS					
ALP	Probe selection for alarm	nP = no probe, the temperature alarms are disabled P1 = Probe 1 (thermostat probe) P2 = Probe 2 (evaporator probe) P3 = Probe 3 (display probe) P4 = Fourth probe	P1	P1	P1
ALC	Temperature alarms configuration	(Ab; rE) Ab = absolute temperature: alarm temperature is given by the ALL or ALU values. rE= temperature alarms are referred to the setpoint. Temperature alarm is enabled when the temperature exceeds the SET + ALU or SET - ALL values.	Ab	Ab	Ab
ALU	Maximum temperature alarm	(SEt to 150°C; SEt to 302°F)When this temperature is reached, the alarm is enabled, after the ALd delay time.	110	56	56
ALL	Minimum temperature alarm	(-100 to SEt; -148°C to 230°F)When this temperature is reached, the alarm is enabled, after the ALd delay time.	-50	10	10
AFH	Differential for temperature alarm recovery	(0.1 to 25.5°C; 1 to 45°F) Intervention differential for recovery of temperature alarm. It is also used for the restartof the fan when the FSt temperature is reached.	2	4	4
ALd	Temperature alarm delay	(0 to 255 min) Time interval between the detection of an alarm condition and alarm signaling.	15	30	30
dAo	Exclusion of temperature alarmat start-up	(from 0.0 min to 23.5 hr)Time interval between the detection of the temperature alarm condition after devicepower ON and alarm signaling.	1.3	2	2

Controller Parameters

CONDENSER TEMPERATURE ALARM					
AP2	Probe selection for temperature alarm of condenser	nP = no probe P1 = thermostat probe P2 = evaporator probe P3 = configurable probe P4 = probe on Hot Key plug	P4	nP	nP
AL2	Low temperature alarm of condenser	(-100 to 150°C) When this temperature is reached, the LA2 alarm is signaled, possibly after the Ad2 delay.	-40	-40	-40
AU2	High temperature alarm of condenser	(-100 to 150°C)When this temperature is reached, the HA2 alarm is signaled, possibly after the Ad2 delay.	110	110	110
AH2	Differential for temperature condenser alarm recovery	(0.1 to 25.5°C; 1 to 45°F)	5	52	52
Ad2	Condenser temperature alarm delay	(0 to 255 min)Time interval between the detection of the condenser alarm condition and alarm signaling.	15	15	15
dA2	Condenser temperature alarm exclusion at start up	(from 0.0 min to 23.5 hr, res. 10 min)	1.3	1.3	1.3
bLL	Compressor OFF with low temperature alarm of condenser	n = no: compressor keeps on working Y = yes, compressor is switched OFF until the alarm is present, in any case regulation restarts after Ac time at minimum.	n	n	n
AC2	Compressor OFF with high temperature alarm of condenser	n = no: compressor keeps on working Y = yes, compressor is switched OFF until the alarm is present, in any case regulation restarts after Ac time at minimum.	n	n	n
AUXILIARY RELAY					
tbA	Alarm relay silencing (with oA3=ALr)	n= silencing disabled: alarm relay stays ON until alarm condition lasts y =silencing enabled: alarm relay is switched OFF by pressing a key during an alarm	y	y	y
oA3	Fourth relay configuration (1-4)	dEF, FAn: do not select it! ALr: alarm; Lig: light; AUS: Auxiliary relay; onF: alwaysON with device ON; db= neutral zone; cP2 = do not select it!; dEF2: do not select it!; HES: night blind	Lig	Alr	Alr
AOP	Alarm relay polarity	Set if the alarm relay is open or closed when an alarm happens. CL= terminals 1-4 closed during an alarm oP = terminals 1-4 open during an alarm	CL	CL	CL
DIGITAL INPUTS					
i1P	Digital input polarity (18-20)	oP = the digital input is activated by opening the contact CL = the digital input is activated by closing the contact	CL	CL	CL
i1F	Digital input configuration (18-20)	dor = door switch functiondEF = activation of a defrost cycle	dor	dor	dor
i2P	2nd digital input polarity (18-19)	oP = the digital input is activated by opening the contact CL = the digital input is activated by closing the contact	CL	CL	CL
i2F	2nd digital input configuration(18-19)	EAL= external alarm: "EA" message is displayed bAL= serious alarm "CA" message is displayed PAL= pressure switch alarm, "CA" message is displayed dor = door switch function dEF= activation of a defrost cycle ES = energy saving AUS = auxiliary relay activation with oA3 = AUS Htr = kind of action inversion (cooling - heating) FAn = fan HdF = Holiday defrost (enable only with RTC) onF = to switch the controller OFF	EAL	EAL	EAL
did	(0 to 255 min) with i2F= EAL or i2F = bAL digital input alarm delay (18-20)	Delay between the detection of the external alarm condition and its signaling. When i2F= PAL: time for pressure switch function: time interval to calculate the number of the pressure switch activation.	15	15	15
doA	Door open signaling delay	(0 to 255 min)	15	15	15
nPS	Pressure switch number	(0 to 15) Number of activation of the pressure switch, during the did interval, before signaling the alarm event (i2F = PAL). If the nPS activation in the did time is reached, switch OFF and ON the device to restart normal regulation.	15	15	15
Odc	Compressor status when open door	no = normal Fan = fan OFF CPr = compressor OFF F_C = compressor and fan OFF	F-C	F-C	F-C
rrd	Outputs restart after doA alarm	no = outputs not affected by the doA alarm yES = outputs restart with the doA alarm	y	y	y
HES	Temperature increase during the Energy Saving cycle	(-30.0°C to 30.0°C) Sets the increasing value of the setpoint during the Energy Saving cycle.	0	0	0
OTHER PARAMETERS					
Adr	Serial address (1 to 244)	Identifies the device address when connected to a MODBUS compatible monitoring system.	1	1	1
pbC	Type of probe	Allows to set the kind of probe used by the device: Pt1 = Pt1000 probe ntc = NTC probe	ntc	ctc	ctc
onF	ON/OFF key enabling	not used = disabled oFF = enabled ES = not set it			
dp1	Thermostat probe display				
dp2	Evaporator probe display				
dp3	Third probe display - optional				
dp4	Fourth probe display				
rSE	Real setpoint	Shows the setpoint used during the energy saving cycle or during the continuous cycle.			
rEL	Software release	For internal use only			
Ptb	Parameter table code	Read-only			

Dixell Control Sensor Location

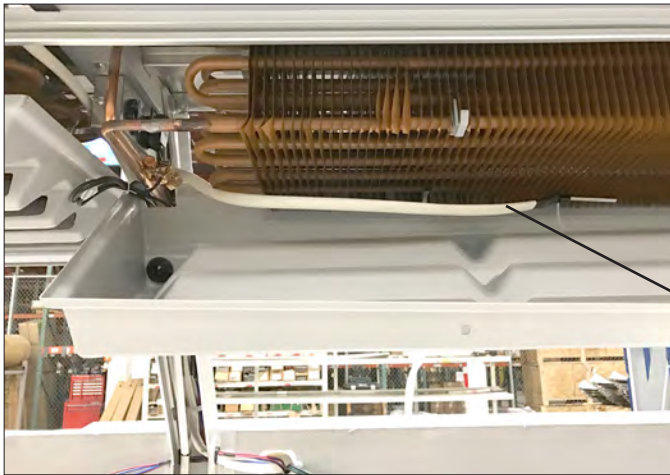

Sensor is located under the gravity coil for SMG8B

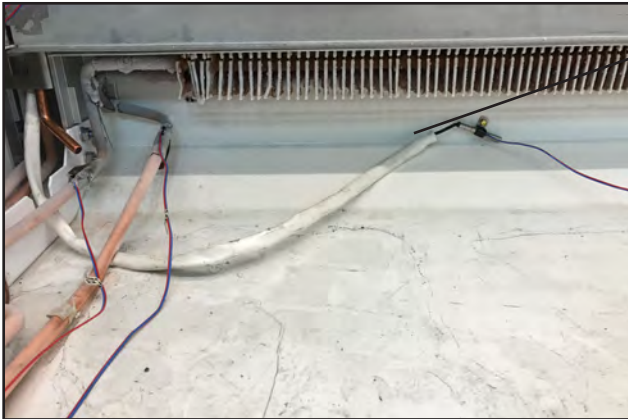

Sensor is located under the coil at the rear of the case for SSG8B

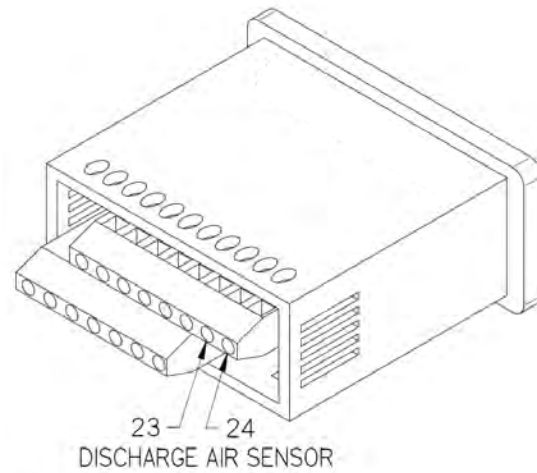

Dixell XR75 Controller

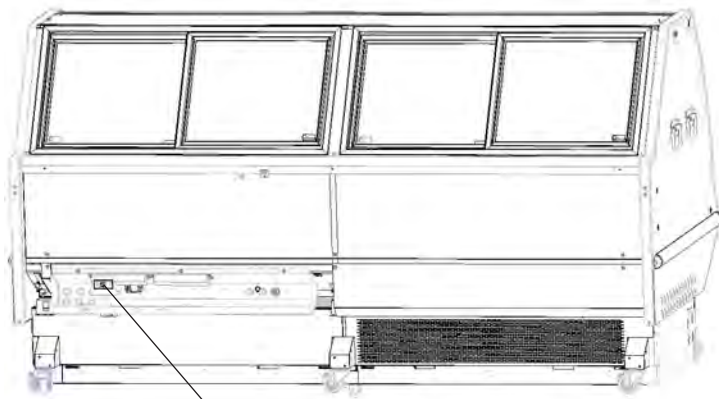

Safe-NET Location on Rear of Case (Rear Panel Removed)

CONTROLS and ADJUSTMENTS

Refrigeration Controls					Defrost Controls		
Model	Product Application	Discharge Air Temperature	Discharge Air Temperature Cut In	Discharge Air Temperature Cut Out	Defrost Frequency (per day)	Type of Defrost	Failsafe Time (Minutes)
SMG	Medium Temp. (Dairy, Deli, Produce)	24° F	25° F	19° F	1	Off Time	90
SSG	Medium Temp. (Dairy, Deli)	21° F	26° F	17° F	1	Off Time	90

START UP

1. The Dixell XR75 Controller controls refrigeration temperature. This is factory installed in the control panel. Measure discharge air temperatures at the center of the honeycomb.

For low temperature models, defrosts are time initiated and temperature terminated. The defrost setting is factory set as shown. To ensure a thorough defrost, the defrost must be terminated by the temperature termination setting — not by time. For medium temperature models, defrost is time initiated and temperature terminated.

Follow the Dixell XR75 start up procedures as detailed on Page 3-1 of this manual.

Each self contained merchandiser has its own evaporator coil and a pre-set thermostatic expansion valve (TEV). The TEV has been factory set at design conditions to provide the recommended performance.

TEV ADJUSTMENT

Expansion valves may be adjusted to fully feed the evaporator. Before attempting to adjust valves, make sure the evaporator is clear or only lightly covered with frost, and the merchandiser is within 10°F of its expected operating temperature.

Adjust the valve as Follows:

- a. Attach a probe to the suction line near the expansion valve bulb.
- b. Obtain a pressure reading from the factory installed Schraeder valve. Convert the pressure reading to a saturated temperature for the refrigerant.

Temperature (b) minus Temperature (a) is the superheat. The valve should be adjusted so that the greatest difference between the two temperatures is 3°F to 5° F.

Make adjustments of no more than 1/2 turn of the valve stem at a time and wait for at least 15 minutes before rechecking the probe temperature and making further adjustments.

SELF CONTAINED (LOCATION)

Product should always be maintained at proper temperature. This means that from the time the product is received, through storage, preparation and display, the temperature of the product must be controlled to maximize the life of the product.

BE SURE TO POSITION SELF CONTAINED MERCHANDISERS PROPERLY.

SELF CONTAINED models have vented base panels to allow air circulation through the condensing unit. Allow for a minimum 4 in. clearance from walls, merchandisers, and any other large objects near the merchandiser's vented base panels (for self contained models). Blocking or restricting air flow will adversely affect performance and may damage the refrigeration system.

LOAD LIMITS

Each merchandiser has a load limit decal. Shelf life of perishables will be short if load limit is violated.

AT NO TIME SHOULD MERCHANDISERS BE STOCKED BEYOND THE LOAD LIMITS INDICATED.



STOCKING

Product should NOT be placed inside the merchandisers until merchandisers are at proper operating temperature.

Allow merchandiser 24 hours to operate before loading product.

Proper rotation of product during stocking is necessary to prevent product loss. Always bring the oldest product to the top and set the newest to the bottom. Do Not stock product beyond shelves

AIR DISCHARGE AND RETURN FLUES MUST REMAIN OPEN AND FREE OF OBSTRUCTION AT ALL TIMES to provide proper refrigeration and air curtain performance. Do not allow product, packages, signs, etc. to block these grilles. Do not use non-approved shelving, baskets, display racks, or any accessory that could hamper air curtain performance. Do not allow product to be placed outside of the designated load limits in the illustration.

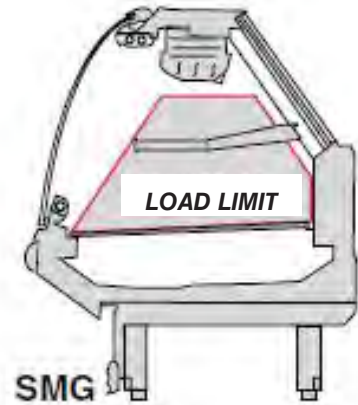

⚠ WARNING
Product will be degraded and may spoil if allowed to sit in a non-refrigerated area.

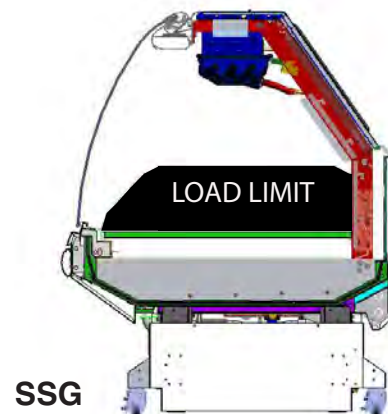

NOTES:

MAINTENANCE

CARE AND CLEANING

Long life and satisfactory performance of any equipment is dependent upon the care it receives. To ensure long life, proper sanitation and minimum maintenance costs, these merchandisers should be thoroughly cleaned, all debris removed and the interiors washed down, weekly.

Exterior Surfaces

The exterior surfaces must be cleaned with a mild detergent and warm water to protect and maintain their attractive finish. **NEVER USE ABRASIVE CLEANSERS OR SCOURING PADS.**

Interior Surfaces

The interior surfaces may be cleaned with most domestic detergents, ammonia based cleaners and sanitizing solutions with no harm to the surface. Self contained models empty into a limited capacity evaporation pan, which will overflow if excess water is used in cleaning.

Do NOT Use:

- Abrasive cleansers and scouring pads, as these will mar the finish.
- Coarse paper towels on coated glass.
- Ammonia-based cleaners on acrylic parts.
- Solvent, oil or acidic based cleaners on any interior surfaces.
- Do not use high pressure water hoses.

WARNING

Product will be degraded and may spoil if allowed to sit in a non-refrigerated area.

Do:

- Remove the product and all loose debris to avoid clogging the waste outlet.
- Store product in a refrigerated area such as a cooler. Remove only as much product as can be taken to the cooler in a timely manner.
- Disconnect electrical power before cleaning.**
- Thoroughly clean all surfaces with soap and hot water. **DO NOT USE STEAM OR HIGH WATER PRESSURE HOSES TO WASH THE INTERIOR. THESE WILL DESTROY THE MERCHANDISERS' SEALING CAUSING LEAKS AND POOR PERFORMANCE.**
- Take care to minimize direct contact between fan motors and cleaning or rinse water.
- Do NOT flood merchandiser with water. **NEVER INTRODUCE WATER FASTER THAN THE WASTE OUTLET CAN REMOVE IT.**

STANDARD CASES ARE EQUIPPED WITH A FLOOR DRAIN. AN OPTIONAL DRAIN KIT IS AVAILABLE.

- Allow merchandisers to dry before resuming operation.
- After cleaning is completed, turn on power to the merchandiser.



WARNING

Do NOT allow cleaning agent or cloth to contact food product.

WARNING

Do NOT use HOT water on Cold glass Surfaces. This can cause the glass to shatter and could result in personal injury. Allow glass fronts, to warm before applying hot water.

REMOVING SCRATCHES FROM BUMPER

Most scratches and dings can be removed using the following procedure.

1. Use steel wool to smooth out the surface area of the bumper.
2. Clean area.
3. Apply vinyl or car wax and polish surface for a smooth glossy finish.

CLEANING UNDER FAN PLENUM

After cleaning be sure the plenum is properly lowered into position OR PRODUCT LOSS WILL RESULT due to improper refrigeration.

WARNING

— LOCK OUT / TAG OUT —

To avoid serious injury or death from electrical shock, always disconnect the electrical power at the main disconnect when servicing or replacing any electrical component. This includes, but is not limited to, such items as doors, lights, fans, heaters, and thermostats.

WARNING

SHUT FANS OFF DURING CLEANING PROCESS.

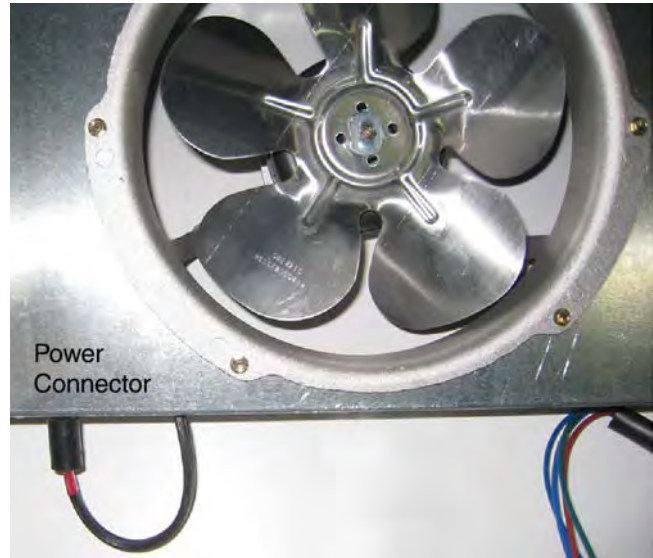

CLEANING DISCHARGE AIR LOUVERS

Discharge air louvers should be cleaned every six months. Dirty louvers will cause merchandisers to perform poorly. The louvers may be cleaned with a vacuum cleaner. Soap and water may be used if all water is removed from the louvers cells before replacing. Be careful not to damage the louvers.

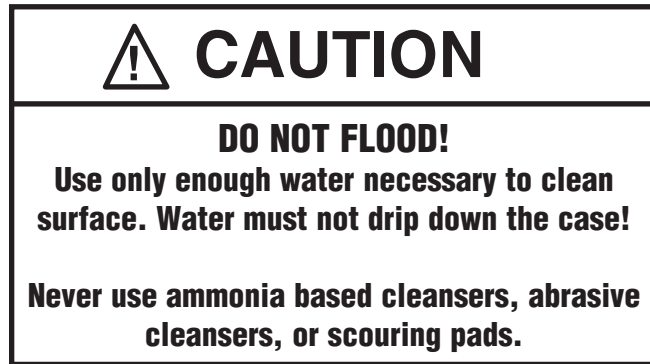

CLEANING STAINLESS STEEL SURFACES

Use non-abrasive cleaning materials, and always polish with grain of the steel. Use warm water or add a mild detergent to the water and apply with a cloth. Always wipe rails dry after wetting.

Use alkaline chlorinated or non-chlorine containing cleaners such as window cleaners and mild detergents. Do not use cleaners containing salts as this may cause pitting and rusting of the stainless steel finish. Do not use bleach.

CLEANING COILS

Condenser coils should be cleaned at least once per month. Additional cleaning may be needed depending on the operational environment. A dirty condenser blocks normal airflow through the coils.

Airflow blockage increases energy consumption and reduces the merchandiser's ability to maintain operating temperature.

To clean the coils, use a vacuum cleaner with a wand attachment and a soft (non-metallic) brush to remove dirt and debris. Do not bend coil fins. Always wear gloves and protective eye wear when cleaning near sharp coil fins and dust particles.

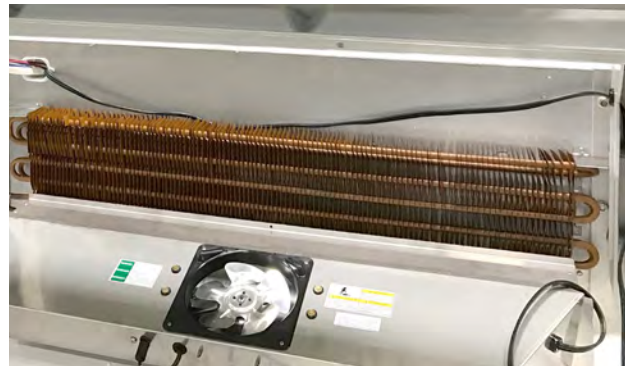

NEVER USE SHARP OBJECTS AROUND COILS. Use a soft brush or vacuum brush to clean debris from coils. *Do not puncture coils!*

Do not bend fins. Contact an authorized service technician if a coil is punctured, cracked, or otherwise damaged.

ICE in or on the coil indicates the refrigeration and defrost cycle is not operating properly. Contact an authorized service technician to determine the cause of icing, and to make adjustments as necessary. To maintain product integrity, move all product to a cooler until the unit has returned to normal operating temperatures.

⚠ CAUTION

Some condensate pans do not have heaters and **MUST** be manually emptied every 24 hrs by the end user.



PRECAUTION

CLEANING PRECAUTIONS

When Cleaning:

- Do not use high pressure water hoses
- Do not introduce water faster than waste outlet can drain
- **NEVER INTRODUCE WATER ON SELF CONTAINED UNIT WITH AN EVAPORATION PAN**
- **NEVER USE A CLEANING OR SANITIZING SOLUTION THAT HAS AN OIL BASE** (these will dissolve the butyl sealants) or an **AMMONIA BASE** (this will corrode the copper components of the merchandiser)

TO PRESERVE THE ATTRACTIVE FINISH:

- Use a water and a mild detergent for the exterior only
- Do **NOT** use a chlorinated cleaner on any surface
- Do **NOT** use abrasives or steel wool scouring pads (these will mar the finish)

CLEANING OPTIONAL DRAIN PAN

The condensate water outlet for self contained models empties into an optional limited capacity drain pan.

Debris or dirt accumulation inside the evaporation pan will reduce the pan's capacity. This may cause the drain pan waste water to overflow and spill onto the floor.

Remove accumulated debris from the drain pan.

A garden hose can be hooked up to the drain pan to drain water. Water introduced during cleaning will cause the drain pan to overflow.

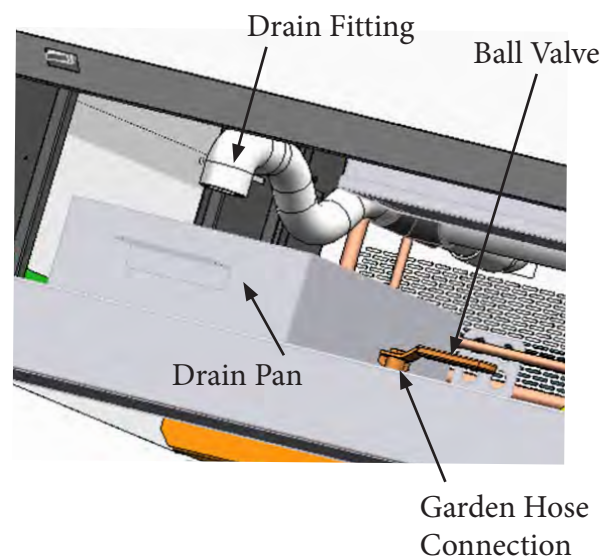

Self-Contained Refrigeration Equipment Maintenance Check List

***** Warranty does not cover issues caused by improper installation or lack of basic preventative maintenance. *****	
Record starting date	
Store Name and Number	
Store Address	
Unit Model Number	
Unit Serial Number	
Contractor/Technician	

	Technician		Q1	Q2	Q3	Q4	Q1	Q2	Q3	Q4
	Quarterly	Semi-Annually								
PM activity-For visual inspection items, denote "ok or complete" in the column to right when PM has been performed. For measured data requested, record data requested in the appropriate column to the right)										
Check in with store manager, record any complaints or issues they have with unit.	X									
Look unit over for any damage, vibrations or abnormal noise.	X									
Verify unit is level side to side and front to rear.	X									
Confirm refrigerant lines properly are secured and not touching or rubbing other lines, wires or frame work.	X									
Verify fan motors and motor mounts are tight.	X									
Confirm fan blade/s are tight and not rubbing or hitting.	X									
Make sure all electrical connections, factory and field, are tight.	X									
Verify electrical connections at lamps are they secure and dry.	X									
Check for and replace any frayed or chaffed wiring.	X									
Check all electrical wiring make sure it is secured and not on any sharp edges or hot lines.	X									
Check for air disturbances external to the unit. Heat and air registers, fans, and doors etc.	X									
Check for water leaks.	X									
Clean evaporator coil/s and fan blade/s. Do not use an acid base cleaner. Rinse off any cleaner residue.		X								
Clean discharge air honeycombs or grilles. Do not use an acid base cleaner. Rinse off any cleaner residue.		X								
Clean condenser coil/s and fan blade/s. Do not use an acid base Cleaner. Rinse off any cleaner residue.		X								
Clean condensate drain pan and drain line.		X								
Verify condensate drain lines are clear and functioning.		X								
Record voltage reading at unit with unit off?		X								
Verify condenser and evaporator fans are working.	X									
Record condenser air inlet temperature	X									
Record condenser air outlet temperature	X									
Is condenser air inlet or air exhaust restricted or recirculating?	X									
Verify there are no visual oil or refrigerant leaks.	X									
Record voltage reading with unit running.		X								
Record compressor amp draw.		X								
Record defrost heater voltage and amp draw.		X								
Record anti-sweat heater voltage and amp draw.		X								
Record case product temperature.	X									
Record unit discharge air temperature.	X									
Record unit return air temperature.	X									
Record ambient conditions around unit (wet Bulb temperature and dry bulb temperature).	X									
Check product loading, do not load beyond the units load limits.	X									
Verify clearances on sides/back of unit.	X									
Check unit controller for proper operation. See controller or 1/0 Manual for proper controller operation.		X								
Confirm door switches function.	X									
Verify unit doors and lids work and are sealed correctly.	X									
Verify that all the panels, shields and covers are in place.	X									

Technician Notes:

NOTES:

SERVICE

REPLACING FAN MOTORS AND BLADES

Should it ever be necessary to service or replace the fan motors or blades be certain that the fan blades are reinstalled correctly. **THE BLADES MUST BE INSTALLED WITH RAISED EMBOSING (PART NUMBER ON PLASTIC BLADES) POSITIONED AS INDICATED ON THE PARTS LIST.**

For access to these fans:

1. Remove product and place in a refrigerated area. Turn off power to the merchandiser.
2. Remove bottom display pans.
3. **Disconnect fan from wiring harness.**
4. Remove fan blade.
5. Lift fan plenum and remove screws holding bottom of motor to fan basket.
6. Replace fan motor and blade.
7. Lower fan plenum.
8. Reconnect fan to wiring harness.
9. Turn on power.
10. Verify that motor is working and blade is turning in the correct direction.
11. Close air gaps under fan plenum. Warmer air moving into refrigerated air reduces effective cooling. If the plenum does not rest against the case bottom without gaps, apply foam tape to the bottom of the fan plenum to reduce improper air movement. Use silicone sealant to close other gaps.
12. Reinstall display pans. Bring merchandiser to operating temperature before restocking.



WARNING

— **LOCK OUT / TAG OUT** —

To avoid serious injury or death from electrical shock, always disconnect the electrical power at the main disconnect when servicing or replacing any electrical component. This includes, but is not limited to, such items as doors, lights, fans, heaters, and thermostats.

**Fan Plenum
SMG cases**

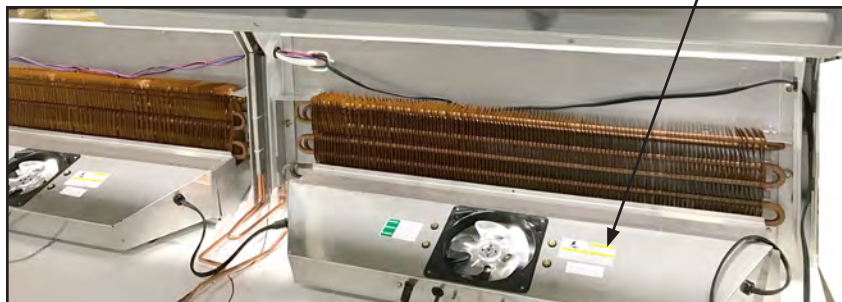

REPLACING CYLINDERS — SINGLE PANE GLASS

CAUTION

Check each glass section monthly to determine if support cylinders are worn and need to be replaced. If the glass does not stay in a raised position, have the cylinders replaced.

Each front curved glass section weighs about 40 lb (18 kg). To prevent glass from falling during installation, use or maintenance and causing injury to customers or personnel, Hussmann recommends one person hold the glass in a raised position while the other person performs cylinder replacement. Support the front glass at all times until cylinder is replaced or the glass is lowered.

NOTICE

Cylinders are a wear item.

They are designed:

- to support the glass when fully open.
- to allow the glass to come down (or close) slowly.

Have your Service Contractor replace the cylinders when required.

When cylinders need to be replaced, the lifting force of the cylinder must be known. The lifting force can be determined by the data printed on the cylinder being replaced. The following shows the part number for the 300N and 400N cylinders.

300N Cylinder – P/N 0412539

400N Cylinder – P/N [0406925](#)

1. Raise the front glass to open completely.
2. Use special hand tool, shown in photo, to compress and remove cylinder.

Note: Cylinders cannot be removed without special hand tool.

Cylinder
Removal
Tool

P/N [0425326](#)

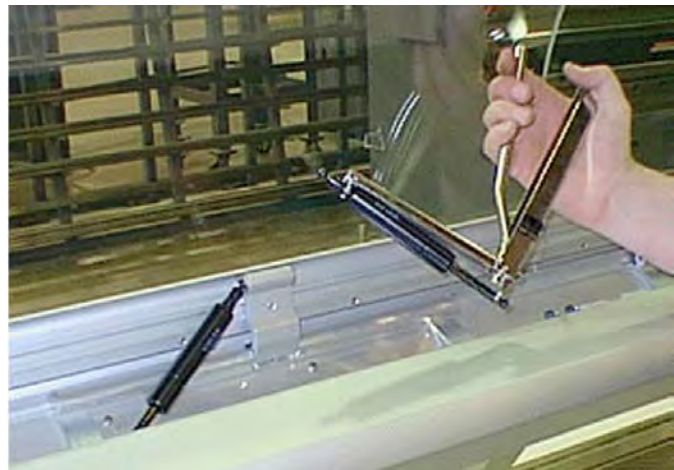

Removing a Cylinder

NOTICE

Cylinder rods must point down so oil will lubricate the rod and seals. Failure to lubricate will severely shorten cylinder life.

REPLACING SINGLE PANE FRONT GLASS (Requires more than one person.)

! WARNING
Once set screws are loose, the glass and glass clamp have NO support or retainers. Support the front glass at all times until the top glass clamp and set screws are secured, or glass is removed.

Apply a drop of Loctite 242 or equivalent threading locking fluid onto each set screw of the glass clamp assembly. Tighten all screws with a TORX T15 bit.

IMPORTANT: Tighten all glass clamp set screws to 26 inch lbs. Verify bit is in good condition and not worn out. When set screws are tightened, glass is firmly held in place by glass clamps.

1. Raise the front glass to open completely.
2. Loosen all set screws along the inside bottom of the glass clamp.

Note: All cylinders do not have to be removed to remove the glass.

IMPORTANT

When reinstalling glass, be certain that:

1. Gasket is on glass evenly.
2. Glass bottom is fully in retainer.
3. When set screws are tightened, glass is firmly held in place by the glass clamps.

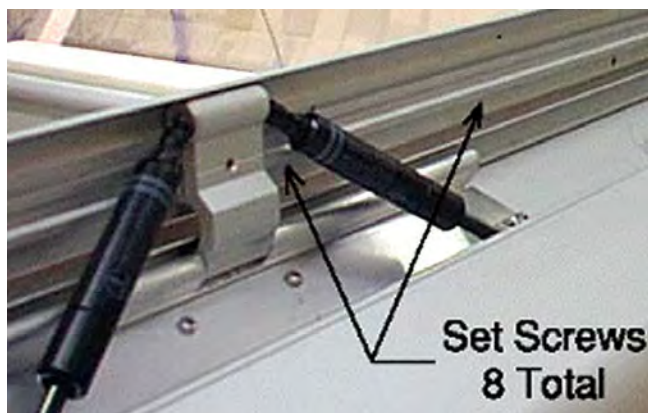
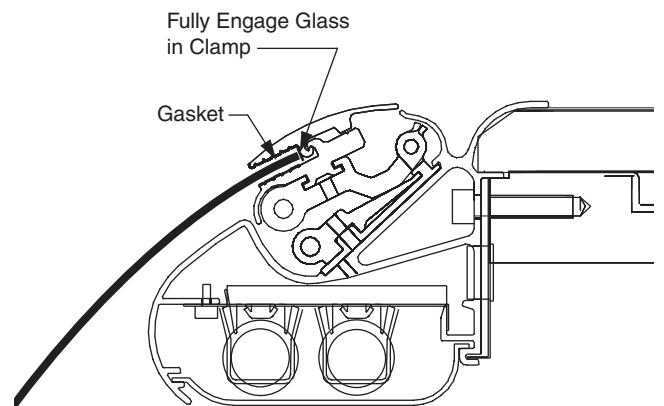
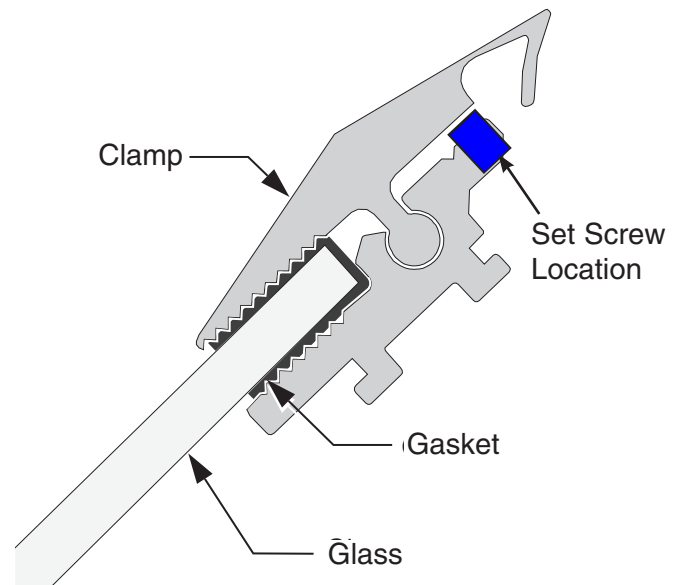

Set Screw Locations

5-4 SERVICE

REPLACING GLASS HAND GRIP

The hand grip is fastened to the curved glass as shown below. A 2 inch (51 mm) bead of silicone needs to be placed 3 inches (76 mm) from each end and in the center of the hand grip. The duct tape is placed on the glass to provide a tight fit.

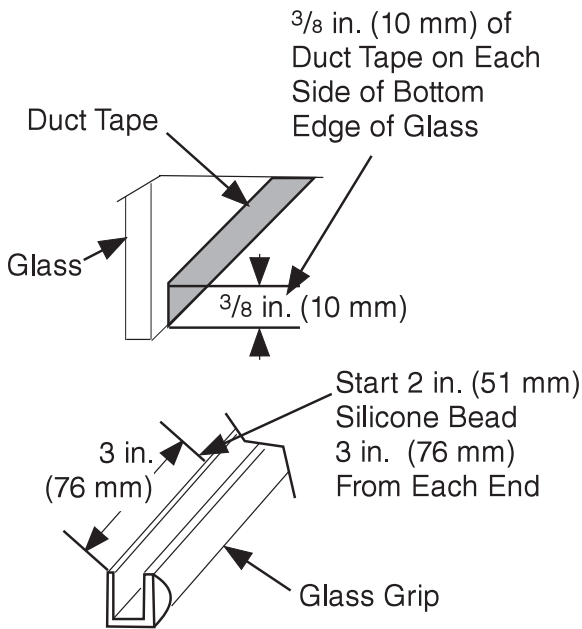

HINGE HARDWARE

Type: Two cylinders and one fastening point.

P/N 0401884

Used on: 8 ft and 12 ft (2438 mm and 3658 mm) parent cases and as a joining bracket.

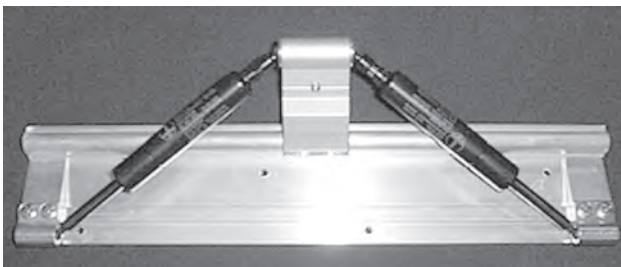

Type: Two cylinders and three fastening points.

P/N 0407352

Used on: 30° outside wedge.

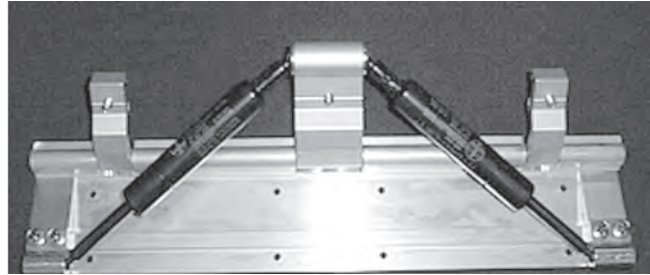

Type: Three cylinders and four fastening points.

P/N 0412538

Used on 90° inside wedge, 45° outside and inside wedge, 30° inside wedge.

Note: This hinge assembly, when used on the 90° and 45° inside wedge, uses only two cylinders.

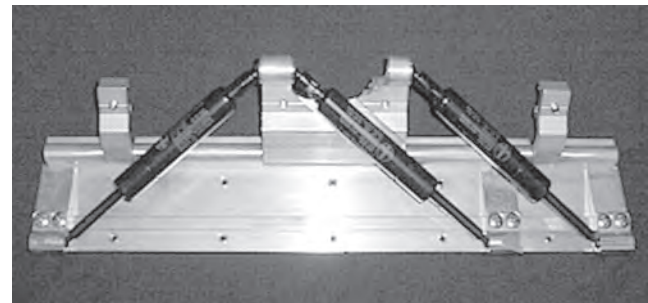

Type: Four cylinders and five fastening points.

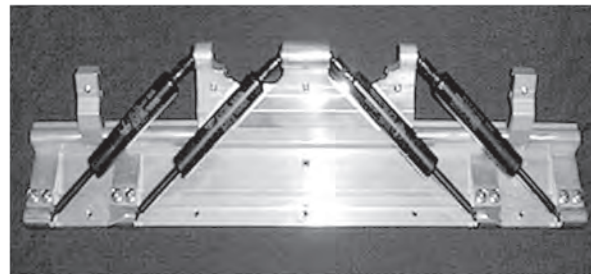

P/N 0413170

Used On: 90° outside wedge.



HUSSMANN[®]

**To obtain warranty information
or other support, contact your
Hussmann representative.
Please include the model and
serial number of the product.**

Hussmann Corporation, Corporate Headquarters: Bridgeton, Missouri, U.S.A. 63044-2483 01 October 2012

Husmann Corporation

12999 St. Charles Rock Road

Bridgeton, MO 63044-2483

www.husmann.com