

HUSSMANN®

Service Merchandisers

Fresh Meat, Delicatessen, and Seafood Merchandisers
(Includes Wedge Installation)
NSF® Certified



***Installation &
Operation Manual***
Shipped with Technical Data Sheets

P/N 0518669_H
January 2022

IMPORTANT
Keep in store for future reference!

Spanish 0532388





BEFORE YOU BEGIN

Read these instructions completely and carefully.



ANSI Z535.5 DEFINITIONS

-  • **DANGER** – Indicate[s] a hazardous situation which, if not avoided, will result in death or serious injury.
-  • **WARNING** – Indicate[s] a hazardous situation which, if not avoided, could result in death or serious injury.
-  • **CAUTION** – Indicate[s] a hazardous situation which, if not avoided, could result in minor or moderate injury.
- **NOTICE** – Not related to personal injury – Indicates[s] situations, which if not avoided, could result in damage to equipment.

The information contained in this document is the property of Hussmann Corporation and shall not be used in whole or in part without written permission.

CAUTION

This manual was written in accordance with originally prescribed equipment that is subject to change. Hussmann reserves the right to change all or part of the equipment for future stores such as, but not limited to, controllers and electrical specifications.

WARNING

Do not use mechanical devices or other means to accelerate the defrosting process.

Do not use electrical appliances inside the food storage compartments of the case(s).

WARNING

Case ventilation openings must be clear of any obstructions. Do not damage the refrigerant circuit.

WARNING

PERSONAL PROTECTION EQUIPMENT (PPE)

Only qualified personnel should install and service this equipment. Personal Protection Equipment (PPE) is required whenever installing or servicing this equipment. Always wear appropriate PPE as required by OSHA regulations, as well as all other federal, state and local codes. PPE may include, but is not limited to, safety glasses, gloves, protective boots or shoes, long pants, and a long-sleeve shirt. Observe all precautions on tags, stickers, labels and literature attached to this equipment.

WARNING

Proper Field Wiring and Grounding Required!
Failure to follow code could result in death or serious injury. All field wiring **MUST** be performed by qualified personnel. Improperly installed and grounded field wiring poses **FIRE** and **ELECTROCUTION** hazards. To avoid these hazards, you **MUST** follow requirements for field wiring installation and grounding as described in **NEC** and your local/state electrical codes.

WARNING

— LOCK OUT / TAG OUT —

To avoid serious injury or death from electrical shock, always disconnect the electrical power at the main disconnect when servicing or replacing any electrical component. This includes, but is not limited to, such items as controllers, electrical panels, condensers, lights, fans, and heaters.

WARNING

Case tipping may occur if cases are not properly leveled and secured.

Table of Contents

| | | | |
|---|------|---|-----|
| INSTALLATION | | Electrical Connections | 2-5 |
| NSF Certification | 1-1 | Field Wiring | 2-5 |
| Location | 1-1 | Identification of Wiring | 2-5 |
| <i>Front Glass Caution</i> | 1-1 | Wiring Color Code | 2-5 |
| Shipping Damage | 1-2 | DRIP PIPING AND SPLASHGUARDS | |
| Apparent Loss or Damage | 1-2 | Waste Outlet and Water Seal | 3-1 |
| Concealed Loss or Damage | 1-2 | Installing Drip Piping | 3-1 |
| Exterior Loading | 1-2 | Installing Splashguards and | |
| Merchandisers Shipped w/ | | Lower Front Panels | 3-4 |
| End Installed | 1-2 | Assembly Diagram | 3-5 |
| Shipping Braces | 1-2 | Installing Bottom Rear Panel | 3-6 |
| Shipping Rider | 1-3 | START UP / OPERATION | |
| Merchandiser Leveling | 1-3 | Start Up | 4-1 |
| Preparation | 1-3 | Stocking | 4-1 |
| Placing Shims | 1-4 | Shelf Maximum Weight Limits | 4-1 |
| Glass Positioning | 1-5 | Load Limits | 4-1 |
| Adjustment Bolt | 1-6 | Load Limit Profiles | 4-2 |
| Joining Instructions | 1-8 | Installing | |
| Installing Coil Cover and Drip Tray . . . | 1-9 | FDA / NSF Required Thermometer . . | 4-2 |
| Removing Protective Film from Bumper | 1-9 | MAINTENANCE | |
| Installing Optional Wrap Board | 1-10 | Care and Cleaning | 5-1 |
| Installing Optional Scale Stand | 1-11 | Exterior Surfaces | 5-1 |
| | | Interior Surfaces | 5-1 |
| REFRIGERATION / ELECTRICAL | | Interior Cleaning Steps | 5-2 |
| Refrigerant | 2-1 | Cleaning Anti-Reflective Glass | 5-6 |
| Refrigerant Piping | 2-1 | Cleaning Stainless Steel Surfaces | 5-6 |
| Connection Location | 2-1 | Cleaning Coils | 5-6 |
| Multiplexing | 2-2 | Maintaining Fluorescent Lamps | 5-7 |
| Line Sizing | 2-2 | Removing Scratches from Bumper | 5-6 |
| Oil Traps | 2-2 | | |
| Pressure Drop | 2-3 | | |
| Insulation | 2-3 | | |
| Suction Line | 2-3 | | |
| Liquid Line | 2-3 | | |
| Control Settings | 2-3 | | |
| Refrigeration Thermostat | 2-4 | | |
| Defrost Termination Thermostat | 2-4 | | |
| Merchandiser Electrical Data | 2-5 | | |

CONTINUED ON PAGE IV.

IMPORTANT
KEEP IN STORE FOR FUTURE REFERENCE

Quality that sets industry standards!

This merchandiser is NSF[®] certified.

12999 St. Charles Rock Road • Bridgeton, MO 63044-2483
U.S. & Canada 1-800-922-1919 • Mexico 1-800-890-2900

www.hussmann.com
© 2022 Hussmann Corporation

HUSSMANN[®]

CONTENTS (CONTINUED)

SERVICE

Replacing Fan Motors and Blades 6-1
 Removing Polycarbonate Lamp Covers 6-2
 Electrical Service Receptacles 6-3
 Replacing Fluorescent Lamps 6-3
 Replacing Lamp Holders and End Caps 6-3
 Replacing Electronic Ballast 6-4
 Replacing Cylinders —Single Pane Glass 6-5
 Replacing Single Pane Front Glass 6-6
 Replacing Glass Hand Grip 6-7
 Hinge Hardware 6-7
 Repairing Aluminum Coils 6-8
 Refrigerant Warning 6-8

WARRANTY 7-1

REVISION HISTORY

REVISION H

- 1. Added Coil Cleaning note, Page 5-6

REVISION G

- 1. Inserted California Warning;

REVISION F — SET SCREW 1-5; 6-6



This warning does not mean that Hussmann products will cause cancer or reproductive harm, or is in violation of any product-safety standards or requirements. As clarified by the California State government, Proposition 65 can be considered more of a ‘right to know’ law than a pure product safety law. When used as designed, Hussmann believes that our products are not harmful. We provide the Proposition 65 warning to stay in compliance with California State law. It is your responsibility to provide accurate Proposition 65 warning labels to your customers when necessary. For more information on Proposition 65, please visit the California State government website.

INSTALLATION

NSF LISTING

These merchandisers are manufactured to meet ANSI / UL 471 standard requirements for safety. Proper installation is required to maintain this listing. Near the serial plate, each case carries a label identifying the type of conditions for which the merchandiser was tested.

ANSI/NSF-7 Type I – Display Refrigerator / Freezer Intended for 75°F / 55%RH Ambient Application

ANSI/NSF-7 Type II – Display Refrigerator / Freezer Intended for 80°F / 55%RH Ambient Application

ANSI/NSF-7 – Display Refrigerator Intended for Bulk Produce

FEDERAL / STATE REGULATION

These merchandisers, at the time they are manufactured, meet all federal and state / provincial regulations.

LOCATION

These merchandisers are designed for displaying products in air conditioned stores where temperature is maintained at or below the ANSI/NSF-7 specified level and relative humidity is maintained at or below 55%.

Placing refrigerated merchandisers in direct sunlight, near hot tables or near other heat sources could impair their efficiency.

Like other merchandisers, these are sensitive to air disturbances. Air currents passing around merchandisers will seriously impair their operation. Do NOT allow air conditioning, electric fans, open doors or windows, etc. to create air currents around the merchandisers.

Product should always be maintained at proper temperature. This means that from the

⚠ WARNING

Read before raising front glass to prevent injury from broken or falling glass.

The top cylinders, which allow the raising and lowering of this glass, have been carefully installed and tested for the proper tension before shipment. However, during shipment and storage, the lubricant inside the cylinders may have settled. This settling can cause excessive or uneven tension on the glass to the point of breakage.

To avoid any damage, please do the following before completely raising the front glass:

1. Slowly raise and lower each glass section 6 times to a height of 6 in. (152 mm).
2. Increase the height to about 12 in. (305 mm) and raise and lower the glass 6 times.
3. Then raise the glass to the full extension and lower.

This should release any settled lubricant in the cylinders and prevent any stress on the front glass.

Leveling and adjustment procedures begin on Page 1-3.

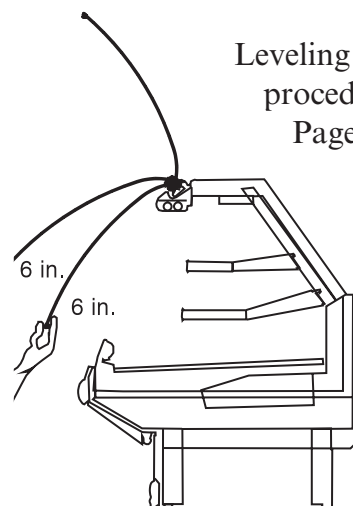

SHIPPING DAMAGE

All equipment should be thoroughly examined for shipping damage before and during unloading. This equipment has been carefully inspected at our factory. Any claim for loss or damage must be made to the carrier. The carrier will provide any necessary inspection reports and/or claim forms.

Apparent Loss or Damage

If there is an obvious loss or damage, it must be noted on the freight bill or express receipt and signed by the carrier's agent; otherwise, carrier may refuse claim.

Concealed Loss or Damage

When loss or damage is not apparent until after equipment is uncrated, retain all packing materials and submit a written request to the carrier for inspection, within 15 days.

EXTERIOR LOADING

Do NOT walk on top of merchandisers or damage to the merchandisers and serious personal injury could occur. Merchandisers ARE NOT STRUCTURALLY DESIGNED TO SUPPORT EXCESSIVE EXTERNAL LOADING such as the weight of a person. Do not place heavy objects on the merchandiser.

MERCHANDISERS SHIPPED WITH END INSTALLED

If the merchandiser was shipped with the end installed, two long bolts were used to hold the shipping brace to the end. If the shipping bolts are reinserted after removing the brace, they will extend into the product area. Therefore, be sure to replace these bolts with the shorter bolts provided. Refer to the detailed information provided in the **separate End Kit Instruction** shipped with each end.

NOTE:

Be careful not to damage the factory installed end while moving the case. Make sure that tools are positioned past the end and beneath the merchandiser's support bar.

SHIPPING BRACES

Move the fixture as close as possible to its permanent location and then remove all packaging and shipping braces. Check for damage before discarding packaging. Remove all separately packed accessories such as kits, and shelves.

Remove all nut retainers used with shipping braces. NSF certification requires the use of ANSI Standard nuts and bolts with not more than two (2) threads showing after installation.

**WARNING**

Do NOT remove shipping braces until the merchandisers are positioned for installation.

**WARNING**

Do not place items or flammable materials atop the case. Do not walk on case.

SHIPPING RIDER

Each merchandiser is shipped on a rider to protect the factory installed front legs, and to make positioning the merchandiser easier.

DO NOT remove the front rider until the merchandiser has been positioned. Once the rider is removed, the case must be lifted –**NOT PUSHED**– to reposition. To remove the rider, remove bolts attaching rider to each leg.

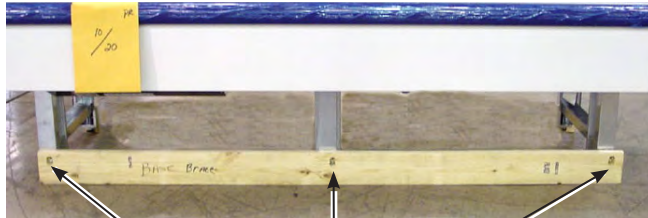

Remove Bolts from Front

MERCHANDISER LEVELING

Merchandisers must be installed level to ensure proper operation of the refrigeration system and to ensure proper drainage of defrost water.

During all steps of setting, joining and leveling merchandisers, close attention to glass position and operation must be maintained. Please review all steps and photos before making any adjustments. **DO NOT** make any glass adjustments until individual merchandiser is set and level.

Preparation

1. Using store blueprints, measure off and mark on floor the exact dimensions/locations of the merchandiser footprint.
2. Snap a chalk line for the front and rear positions of the base legs.

3. Mark the location of each joint from front to back lines.
4. **FLOORS ARE NOT LEVEL!!!** When working with two or more merchandisers to be joined, the whole lineup must be leveled on the same plane, left to right and front to back. This means that the entire lineup must be brought up to the level of the highest merchandiser in the lineup.

Along the lines previously marked, find the highest point of the floor by:

- Walking the floor and noticing any dips or mounds;
- Using a string level; and
- Using a transit.

1-4 INSTALLATION

Placing Shims

Level the case by all four corners. Start at the rear by placing the provided shims as needed under each end of the rear base rail. The shims are long enough to allow adjoining wall cases to be leveled with the same shim. **When the rear of the case is level end-to-end, move to the front of the case.** Use shims as needed at each front corner so that the front is also level from end-to-end and front-to-rear.

The merchandiser should be solidly supported at least every 4 feet (1220 mm). Once the merchandiser is level, if any gaps are present under the base rail, shims should be inserted approximately in line with the center front support legs to support the rear of the case. At the front of the case, insert shims under each of the center legs so that they support the front of the merchandiser. Check all 6 legs on 8 ft (2438 mm) merchandisers, or 8 legs on 12 ft (3658 mm) merchandisers.

Attention to glass position is critical during the leveling process.

Shims will affect the position of the glass. Make certain that the glass is square with the merchandiser, avoiding interference with other glass and ends.

If the glass is still out of alignment, refer to the following *Glass Positioning* instructions.

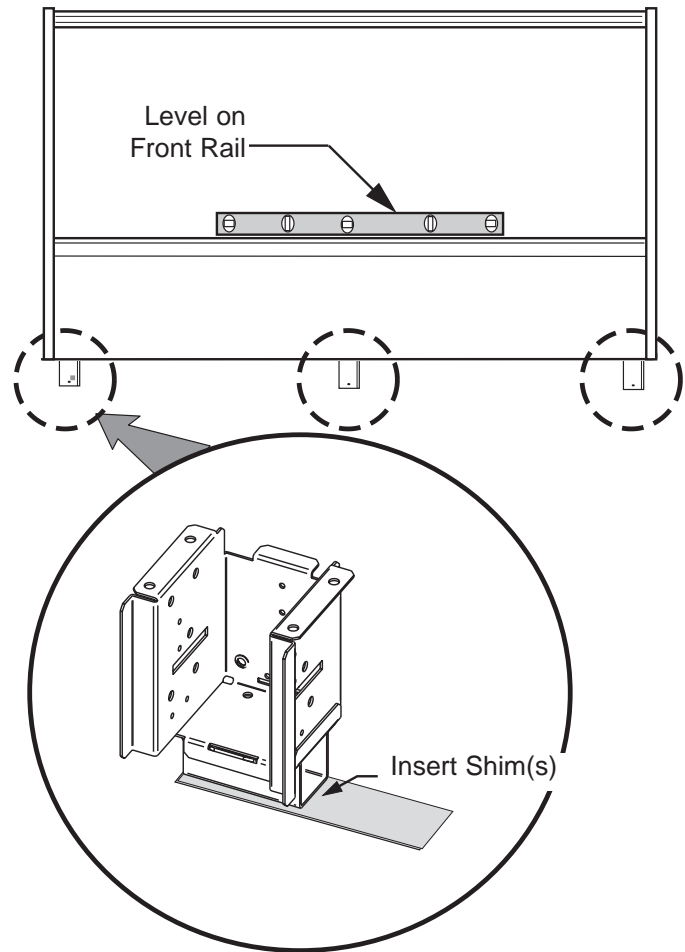

NOTICE

Do not adjust glass until merchandiser is leveled. In many instances, proper leveling will align glass without further adjustment.

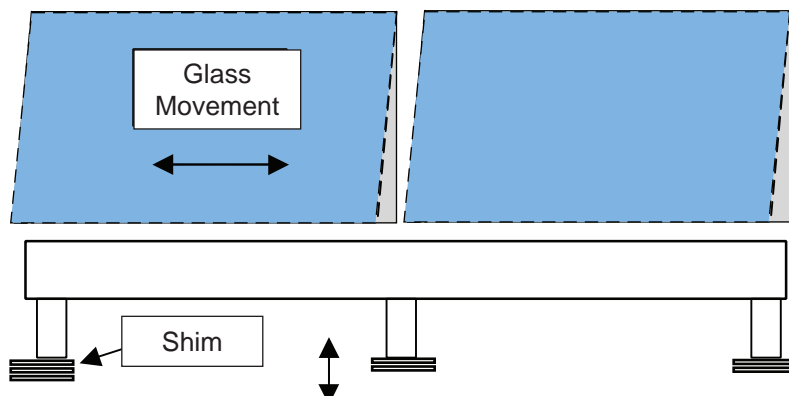

WARNING

To prevent injury from falling glass during adjustment, one person must support glass while a second person makes adjustments.

GLASS POSITIONING

Check the following to improve opening or closing of the merchandiser front glass.

1. Has the merchandiser been leveled according to preceding paragraphs?
2. Is the glass handle installed correctly?

Verify the glass is bottomed out the length of the handle. A bowed handle indicates the glass may not be bottomed out at the center of the handle.

The handle must be removed before it can be repositioned. The handle is held in place with silicone which must be completely removed from the handle and the glass. Remove the handle by pulling it away from the glass (do not use tools to pry this loose). A damaged or bent handle must be replaced. Apply new silicone into the handle and firmly press onto the glass.

3. Is the glass seated in the clamp hardware correctly?

Verify glass is bottomed out in clamp hardware. If the glass is not bottomed out in the clamp hardware it can be re-positioned as follows:



- A. Remove the glass and clamp hardware from the merchandiser by opening the glass and loosening set screws in hinge (Metric 3 millimeter set screws).
- B. Slide the glass and clamp hardware to the side out of the hinges and lay them on an appropriate work surface.
Note: Adjacent glass must be closed.
- C. Loosen the 8 set screws on the underside of the clamp hardware.
- D. Push the clamp hardware onto the glass until bottomed out.
- E. The clamp hardware must overhang the glass by an equal amount on each side.
- F. Tighten set-screws and re-install on merchandiser. Apply a drop of Loctite 242 or equivalent thread locking fluid onto each set screw of the glass clamp assembly. Tighten all screws with a TORX T15 bit and re-install onto merchandiser.

IMPORTANT: Tighten all glass clamp set screws to 26 inch lbs. Verify bit is in good condition and not worn out. When set screws are tightened, glass is firmly held in place by glass clamps.

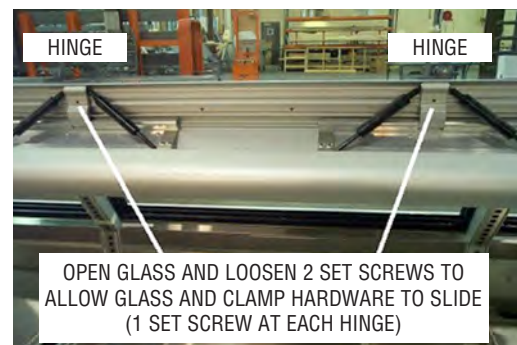

1-6 INSTALLATION

4. Is the glass hitting the end or adjacent glass? Slowly open and close the glass to inspect. If the glass is hitting the end or adjacent glass it may not be positioned correctly from left to right. This can be adjusted as follows:

- Loosen the 2 screws holding the hinge to the clamp hardware (Metric 3 millimeter screws).



- Slide the clamp hardware to either side as needed.
- Tighten the screws and check glass for proper operation.

5. Is the glass still hitting adjacent glass?
Slowly open and close the glass to inspect.

Optional Flexible Wiper Gasket

There may be an optional flexible wiper gasket that is attached to each side. These are designed to overlap each other, sealing the gap between the glass and allowing side-to-side glass adjustment. After all glass has been adjusted as defined in Step 4, the flexible portion of one gasket at a joint may be trimmed with a razor knife. Be sure that the remaining wiper gasket seals the gap. Verify proper operation.

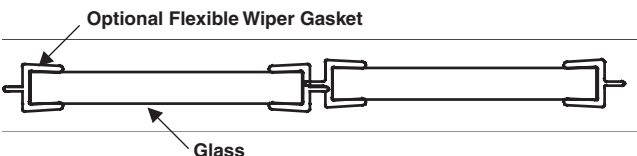

ADJUSTMENT BOLT

If the glass still does not open or close correctly, adjustment of the top frame may be necessary.

This merchandiser is equipped with an adjustment bolt at the top rear of the merchandiser to raise or lower the glass. This allows for improvements in the glass operation and sealing. The following outlines how to access the adjustment bolt. The top must be free to move as the adjustment bolt is turned.



1. Loosen joining or end bolts at top of merchandiser, (2 at each end of merchandiser).
2. If caulk or silicone has been applied between merchandiser joints or ends in the top area it must be removed.
3. Remove rear doors.

- Remove screws at top of rear door frame. The bottom screws do not need to be removed.



- Pull back the top of the door frame approximately 2 inches. This will allow clearance for removal of the stainless steel top liner and trim pieces.

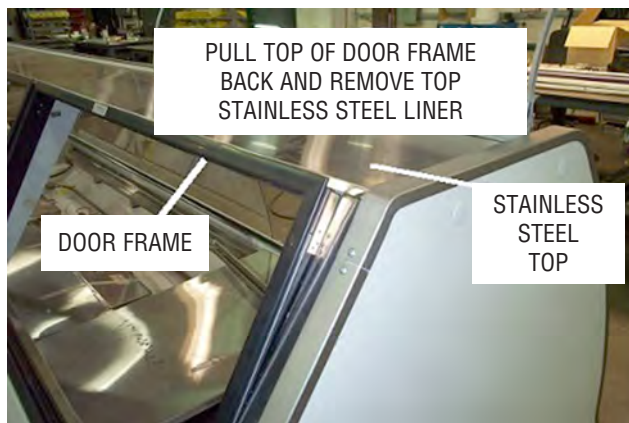

- Some models have a Phillips truss head screw holding the stainless steel liner to the trim. These screws are visible from the rear of the merchandiser to the side of the door frame. These must be removed.

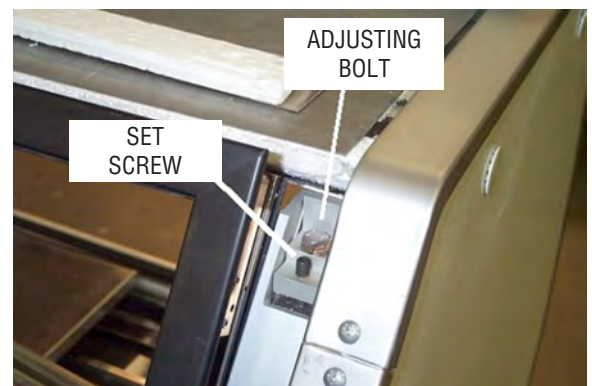

- Remove stainless steel top liner by grabbing the rear flange and pulling back. Note: It is possible to access the adjusting bolt by using a small swivel socket without removing the stainless top liner. To do this, the stainless steel trim and foam noted in Step 8 must be removed.

1-8 INSTALLATION

8. Remove stainless steel trim pieces and foam insulation on each side of the door frame.
9. The set screw and adjusting bolt are now accessible.

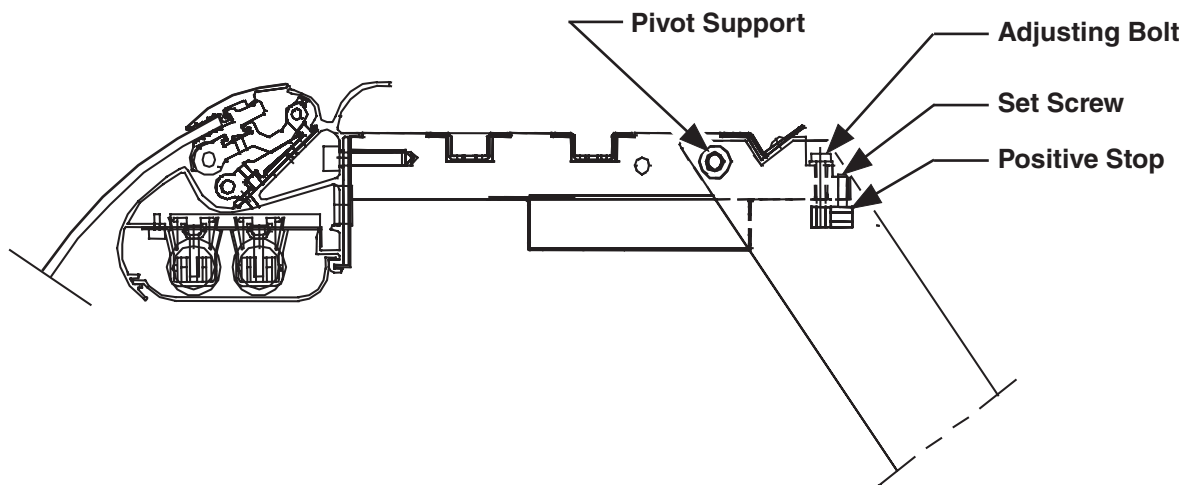

- The set screw must be backed out before turning the adjusting bolt ($\frac{1}{8}$ inch set screw). The set screw serves as a positive stop.
- The adjusting bolt should be turned no more than a half-turn before inspecting glass position and operation.
- Turning the adjusting bolt clockwise will raise the front glass.
- Turning the adjusting bolt counter-clockwise will lower the front glass.
- Once the glass position is set, tighten the set screw (positive stop).

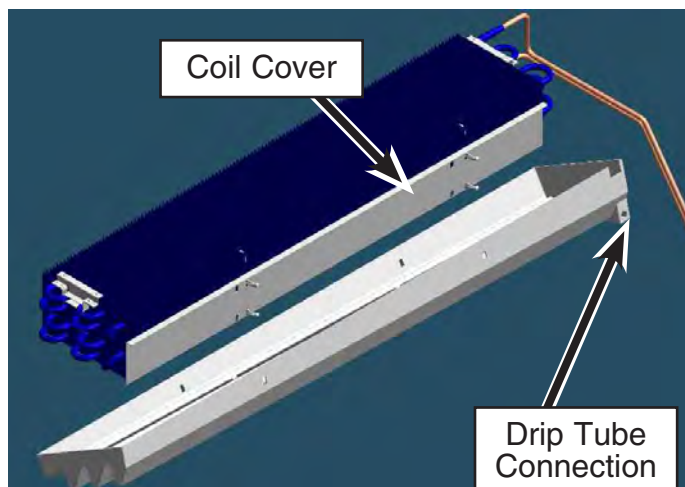

10. Once glass is positioned and operating correctly, re-install components and hardware removed.

Note: The door frame is designed to have a tight fit. A putty knife between the top of the frame and the insulated panel will help guide

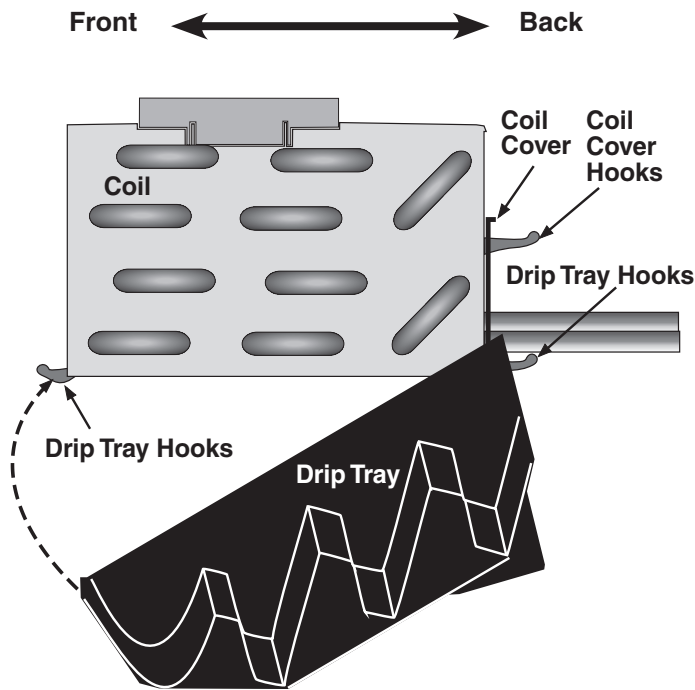

it into position.

11. Re-apply caulk or silicone as required.

12. Verify glass is positioned and operating correctly.

JOINING INSTRUCTIONS

Sectional construction means that two or more merchandisers may be joined in line yielding one long continuous display requiring only one pair of ends.

All joints must be air-tight to prevent formation of ice or condensation.

Refer to the detailed information provided in the separate *Joining Instruction* shipped with each merchandiser.

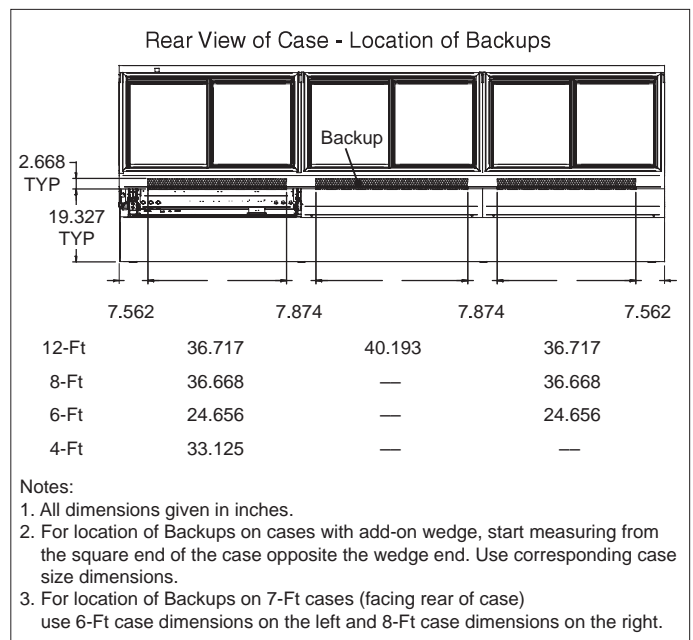
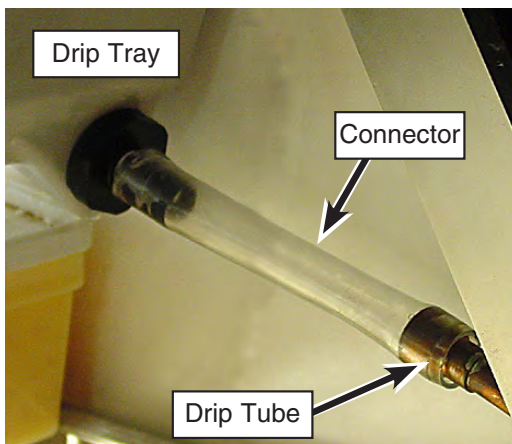

INSTALLING COIL COVER AND DRIP TRAY

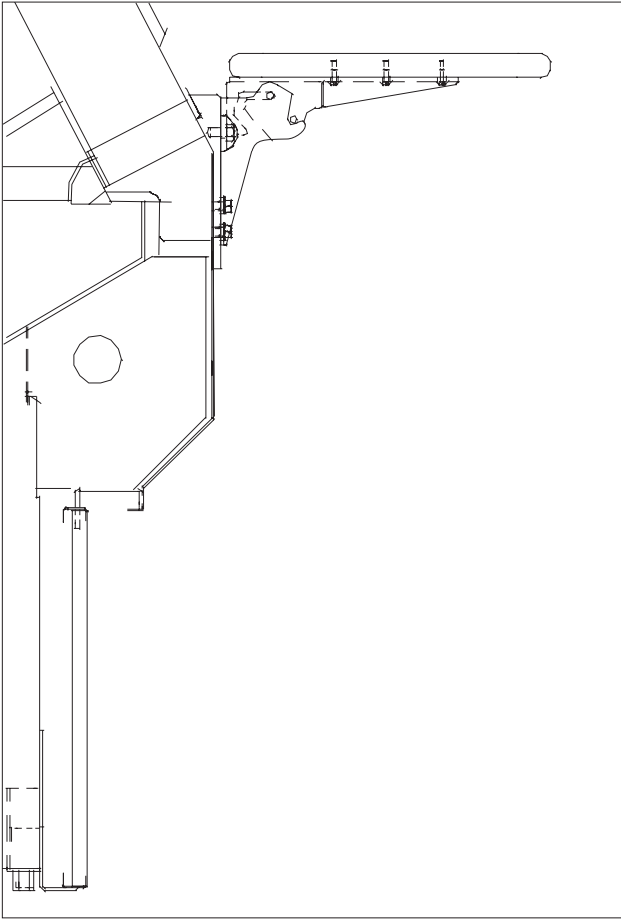

Each gravity coil in these service merchandisers has a 4 ft (1219 mm) stainless steel coil cover and molded plastic drip tray. A condensate drip tube is factory installed. Check the drip tray for obvious damage before installation. Damaged or leaking drip trays must be replaced. Remove any loose debris and clean the drip tray before installing. Coil cover hooks and drip tray hooks are factory installed at the front and back in each gravity coil. Hanging holes are formed in the cover and drip tray.

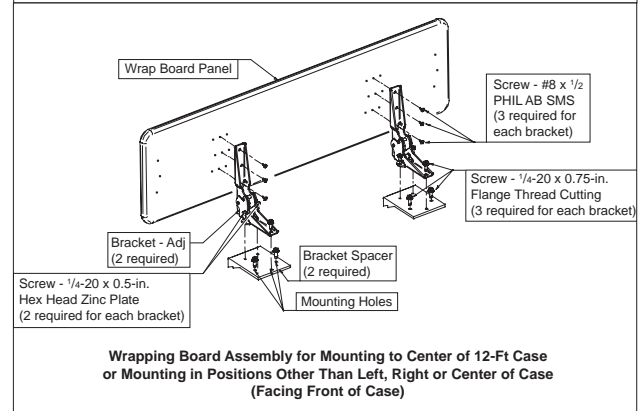
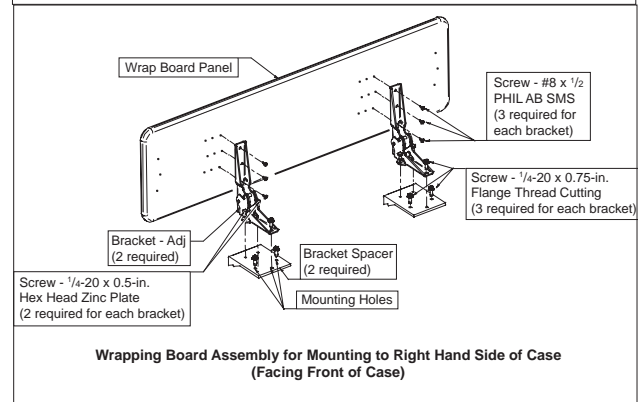
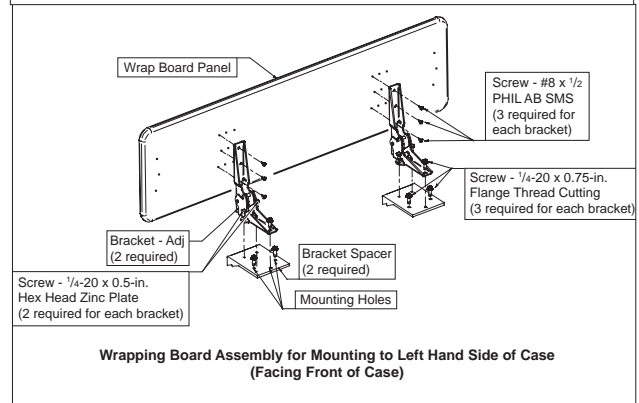
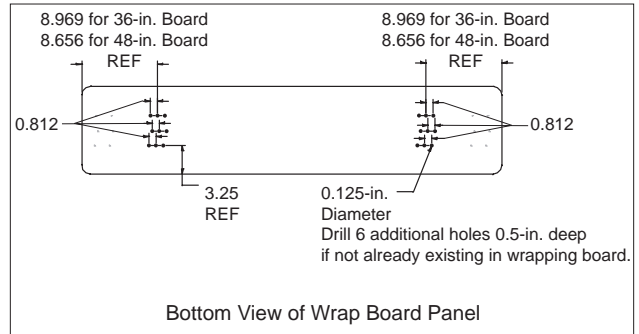

From the back of the merchandiser, hang the coil cover from the top hooks, then position the drip tray in the merchandiser with the drip tube connection to your right. Hang drip tray on two back hooks and two front hooks.

Connect installed copper drip tube to drip tray using flexible connector supplied.

Ensure condensate flows freely from drip tray through drip tube. Check the drip tube connection for leaks before stocking.

REMOVING PROTECTIVE FILM FROM BUMPER

Remove protective film from bumper once installation is complete.8. Reposition top over rear door center trim and attach using #8 truss head screws.

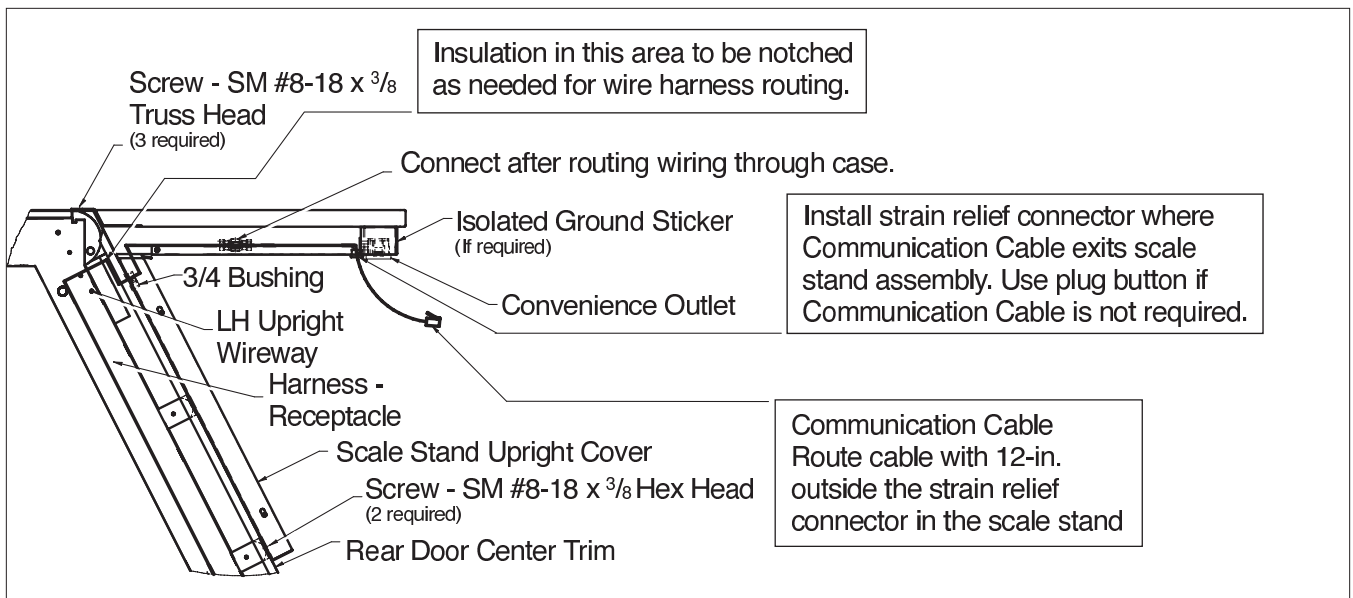
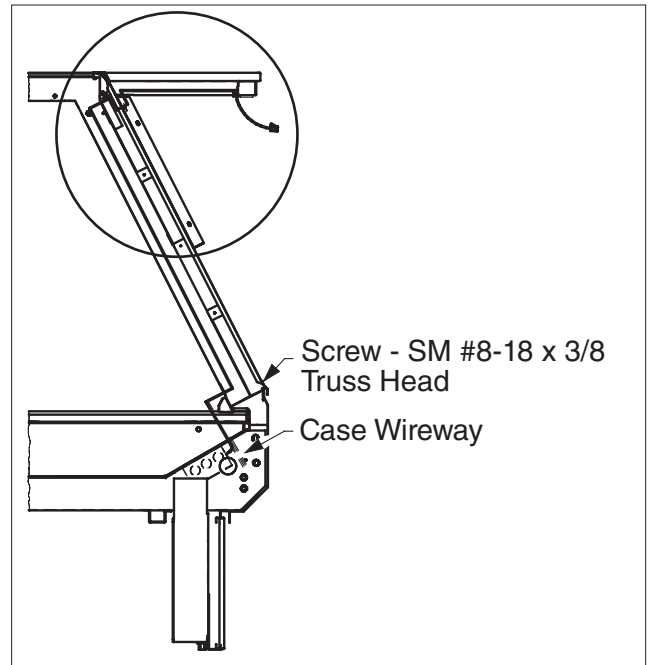

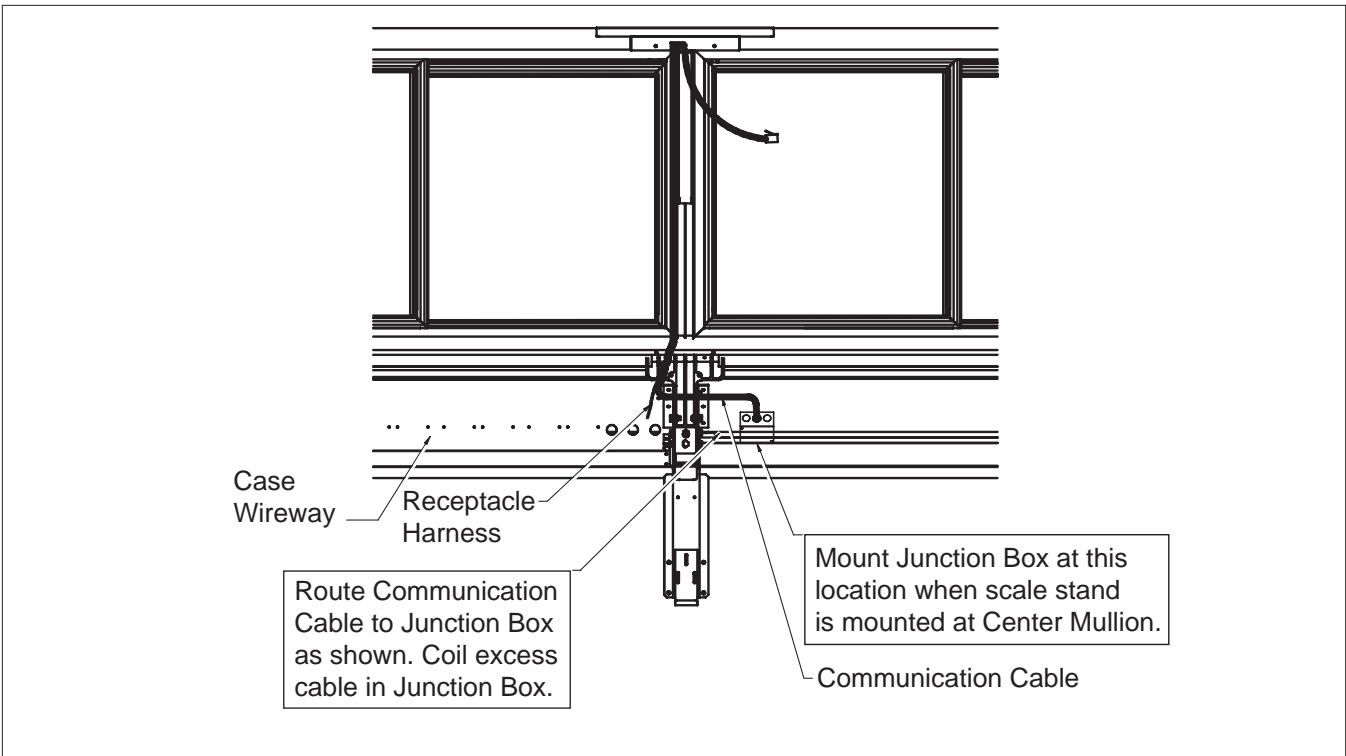

REFRIGERATION / ELECTRICAL

 **WARNING**

Refrigerant vapor is hazardous to your health and can cause death.

Avoid breathing refrigerant and lubrication vapor or mist. Exposure may irritate eyes, nose and throat. If accidental system discharge occurs, ventilate work area before resuming service.

Always wear safety goggles and protective gloves when working with refrigerants. Contact with refrigerant may cause injury. Disconnect hoses with extreme caution! All hoses may contain liquid refrigerant under pressure.

Be sure that any room where you are working is thoroughly ventilated, especially if a leak is suspected.

Read all safety information regarding the safe handling of refrigerant and refrigerant oil, including the Material Safety Data Sheet. MSDS sheets can be obtained from your refrigerant supplier.

Refrigeration lines are under pressure and should be depressurized before attempting to make any connections.

When brazing pipes, be sure to use the insulation blanket shipped with the merchandiser to prevent fire or damage to the plastic merchandiser bottom.

REFRIGERANT

The correct type of refrigerant will be stamped on each serial plate. The merchandiser refrigeration piping is factory sealed, pressurized and leak tested. Before making refrigeration hookups, depress universal line valve to ensure that coils have maintained pressure during shipment.

REFRIGERANT PIPING**Connection Location**

The refrigerant line connections are at the right-hand end of the merchandiser (as viewed from the front) beneath the display pans. A sticker marks the location of the connection “pod.” The installer must saw a hole through the pod to exit the merchandiser. After connections have been made, seal this outlet thoroughly. Seal both the inside and the outside. We recommend using an expanding polyurethane foam insulation.

A refrigeration shroud ships with each merchandiser. Before making connections, place the refrigeration shroud over refrigeration piping so that when the shroud is rotated into place, it will be in the upright position. The Figure 2-1 shows the correct orientation.

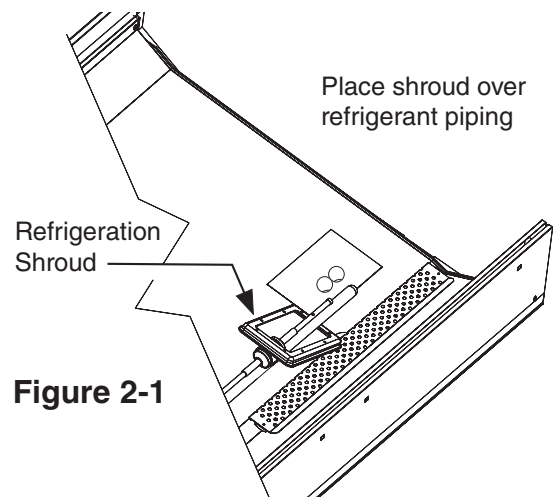
**Figure 2-1**

2-2 REFRIGERATION / ELECTRICAL

Be careful not to burn, scorch or over-heat the shroud when making connections.

Once connections have been made, apply silicone sealant to the bottom of the shroud as shown in Figure 2-2.

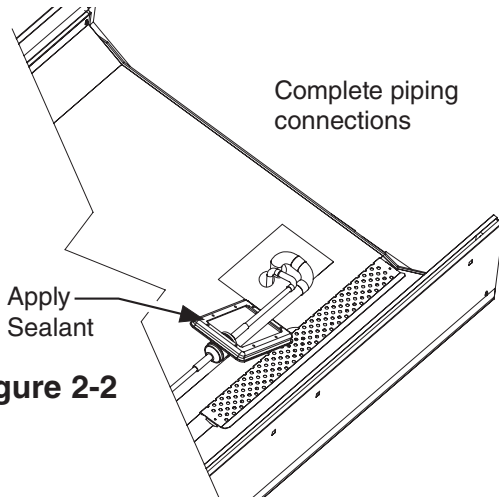

Figure 2-2

As shown in Figure 2-3, rotate and center the shroud over the refrigeration outlet foam pad, then fasten to the interior liner of the bottom.

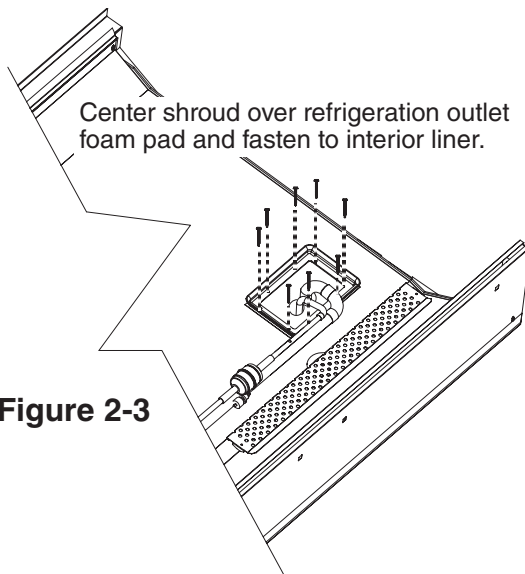

Figure 2-3

After connections have been made, seal this outlet thoroughly. Seal both the inside and the outside. We recommend using an expanding polyurethane foam insulation. Cover foam with silicone to prevent water from entering foam.

Multiplexing

Piping of merchandisers operating on the same refrigeration system may be run from merchandiser to merchandiser. **DO NOT RUN REFRIGERANT LINES THROUGH MERCHANDISERS THAT ARE NOT ON THE SAME REFRIGERATION SYSTEM BRANCH** as this may result in poor refrigeration control and compressor failure.

Interconnecting piping inside the merchandiser must be located as shown below to allow room for lifting the hinged fan plenums and for clearance beneath the display pans. The interconnecting piping may be run outside the merchandiser.

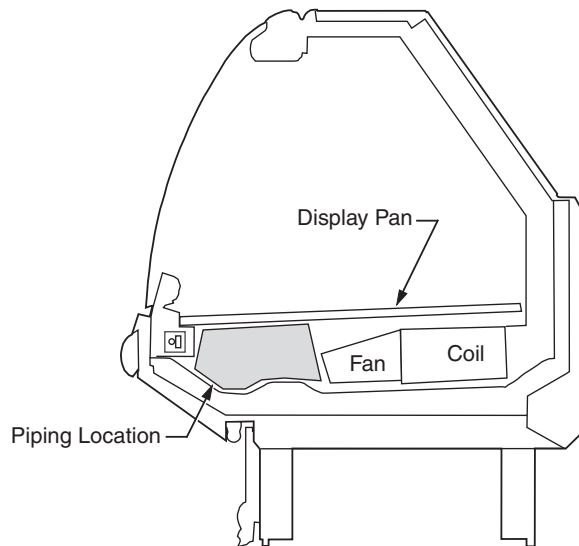

Line Sizing

Refrigerant lines should be sized as shown on the refrigeration legend that is furnished for the store or according to ASHRAE guidelines. Refer to the information on the next page for branch line piping of Hussmann Equipment.

Oil Traps

P-traps (oil traps) must be installed at the base of all suction line vertical risers.

Pressure Drop

Pressure drop can rob the system of capacity. To keep the pressure drop to a minimum, keep the refrigerant line run as short as possible using a minimum number of elbows. Where elbows are required, USE LONG RADIUS ELBOWS ONLY.

INSULATION

The suction and liquid lines should be clamped or taped together and insulated for a minimum of 30 ft (9144 mm) from the merchandiser. Additional insulation for the balance of the liquid and suction lines is recommended wherever condensation drip-pipe is objectionable or lines are exposed to ambient conditions.

SUCTION LINE

- Pitch in direction of flow.
- May be reduced by one size at one third of merchandiser run load and again after the second third. Do not reduce below the merchandiser suction line size.
- Merchandiser suction lines should enter at the top of the branch line.

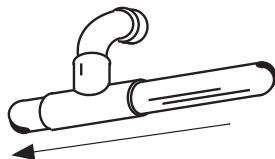

Suction Line Return

LIQUID LINE

- May be reduced by one size after one half the merchandiser run load. Do not reduce below the merchandiser liquid line connection size.
- Take-offs to merchandiser liquid lines should exit the bottom of the branch liquid line. Provide an expansion loop for each evaporator take-off. (Minimum 3 in. [76 mm] loop.)

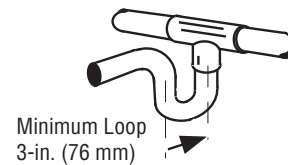

Liquid Line Take Off

CONTROL SETTINGS

Merchandiser Technical Data Sheets (TDS) are shipped with this manual. The TDS provide merchandiser control settings and defrost data.

An evaporator pressure regulator or EPR (primary control) and a 3 – 5°F (1.7 – 2.7°C) differential thermostat (secondary control) must control refrigeration temperature. The EPR must be set to maintain the proper saturated evaporator temperature as listed in the data sheets. The thermostat must be set a couple degrees colder than the discharge air temperature specified in the data sheets. The thermostat will prevent product freezing should the EPR temperature drift downward during reduced load periods (lights off, lower ambient). The thermostat will be wired to control the compressor motor contactor (single compressor) or a liquid line solenoid valve (parallel compressor systems).

Offtime Defrost

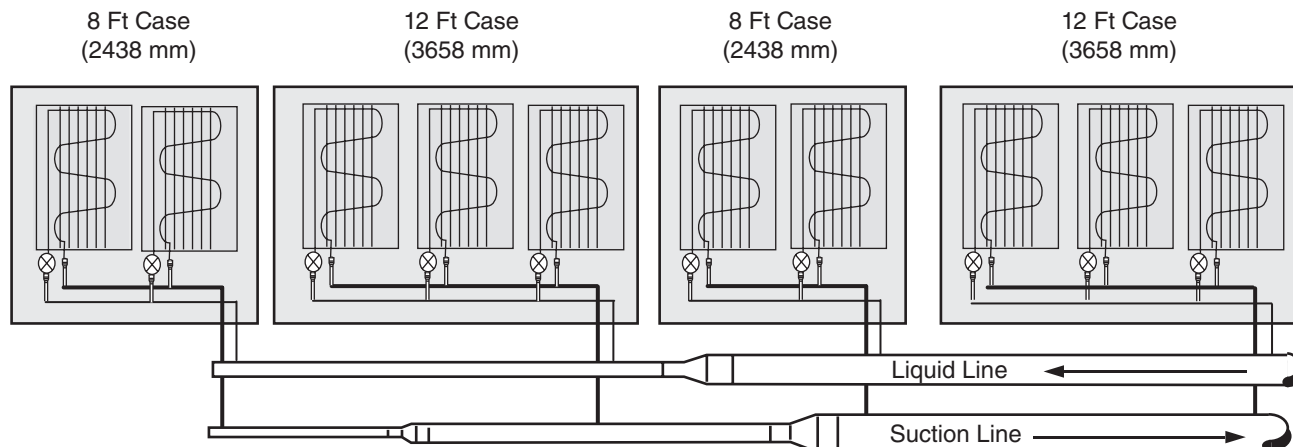

Defrost is Off Time. Defrost control settings are listed in the data sheets. When these merchandisers are connected to parallel compressor systems, a suction stop valve must be used to isolate the evaporator during defrost periods.

REFRIGERATION THERMOSTAT

The optional refrigeration thermostat bulb is located in the discharge air of the evaporator. The optional refrigeration thermostat is located behind the exterior rear panel.

DEFROST TERMINATION THERMOSTAT

The standard disc type defrost termination thermostat is not adjustable. This thermostat is clamped to the inlet of the coil on the left-hand (facing front) end of the merchandiser.

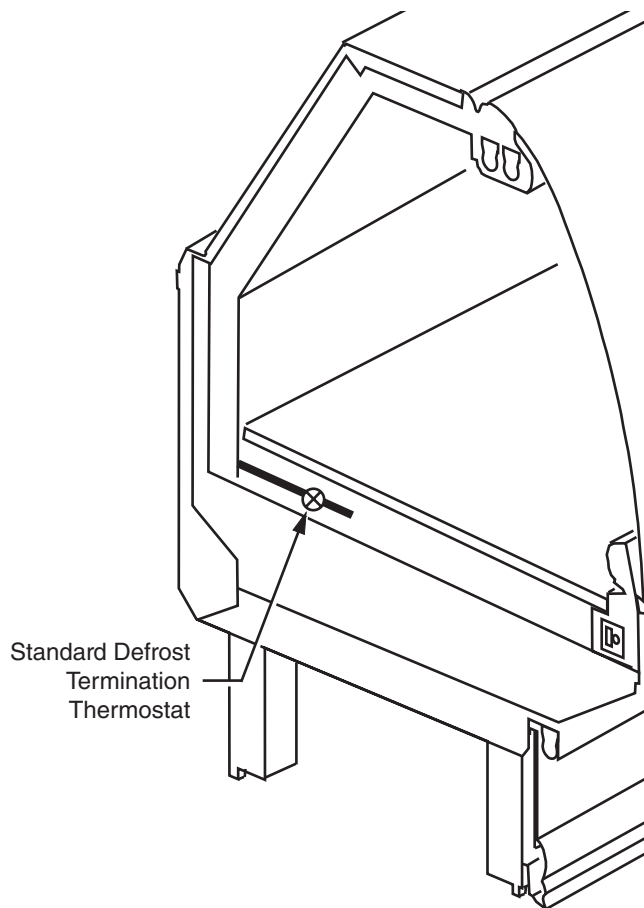

MERCHANDISER ELECTRICAL DATA

Merchandiser data sheets are shipped with this manual. The data sheets provide merchandiser electrical data, electrical schematics, parts lists and performance data. Refer to the merchandiser data sheets and merchandiser serial plate for electrical information.

ELECTRICAL CONNECTIONS

All wiring must be in compliance with NEC and local codes. All electrical connections are to be made in the electrical raceway or *Handy Box*.

FIELD WIRING

Field wiring must be sized for component amperes stamped on the serial plate. Actual ampere draw may be less than specified. Field wiring from the refrigeration control panel to the merchandisers is required for defrost termination thermostats and for optional refrigeration thermostats. When multiple merchandisers are on the same defrost circuit, the defrost termination thermostats are wired in series.

**ALWAYS CHECK THE SERIAL
PLATE FOR COMPONENT
AMPERES.**

IDENTIFICATION OF WIRING

Leads for all electrical circuits are identified by colored plastic bands. These bands correspond to the *color code sticker* (shown below) located inside the merchandiser's wireway.

WIRING COLOR CODE

Leads for all electrical circuits are identified by a colored plastic band: neutral wire for each circuit has either White insulation or a White plastic sleeve in addition to the color band.

| | |
|---|--|
| PINK.....REFRIG. THERMOSTAT LOW TEMP. | ORANGE OR |
| LIGHT BLUE ...REFRIG. THERMOSTAT NORM TEMP. | TANLIGHTS |
| DARK BLUE....DEFROST TERM. THERMOSTAT | MAROON ..RECEPTACLES |
| PURPLECONDENSATE HEATERS | YELLOW ...DEFROST HEATERS 120V |
| BROWN.....FAN MOTORS | REDDEFROST HEATERS 208V |
| GREEN*GROUND | *EITHER COLORED SLEEVE OR COLORED INSULATION |

**ELECTRICIAN NOTE: Use copper conductor wire only.
MERCHANTISER MUST BE GROUNDED**

THESE ARE MARKER COLORS. WIRES MAY VARY.

Notes

DRIP PIPING AND SPLASHGUARDS

WASTE OUTLET AND WATER SEAL

Each merchandiser has two waste outlets. The waste outlets are located in front of the fan plenum 12 inches (305 mm) from either end of the merchandiser. Two water seals, two tees, two extensions and two clean-out plugs are supplied for each merchandiser. The water seal must be installed with the waste outlets to prevent air leakage and insect entrance into the merchandiser.

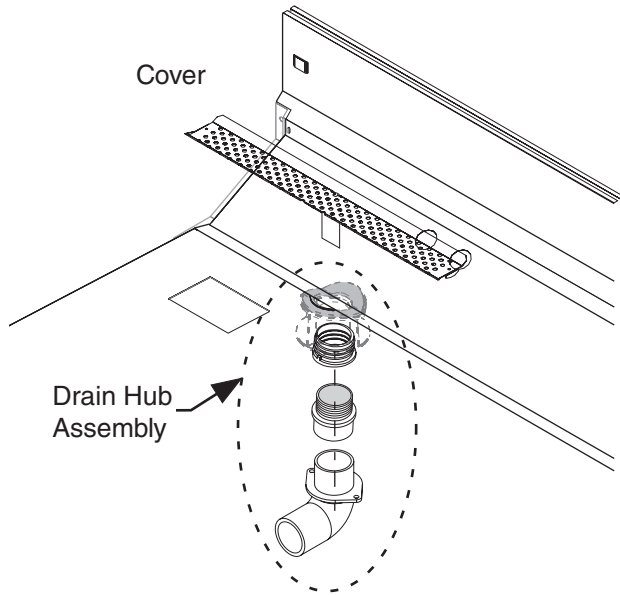

Items Factory Installed for Excel Waste Outlet
(on Each End of Case)



CAUTION

Splashguard brackets **MUST** be installed before piping merchandiser.

INSTALLING DRIP PIPING

Poorly or improperly installed drip pipes can seriously interfere with the merchandiser's operation and result in costly maintenance and product losses.

Optional drip pipe arrangements are shown on the next page. It is the installing contractor's responsibility to consult local agencies for local code requirements. Assemble the components using field-supplied PVC primer and glue according to the manufacturers direction.

Never use PVC primer or glue on ABS drain fittings, because it may damage or crack the fitting. Always hand tighten drain fitting if it's not already factory installed.

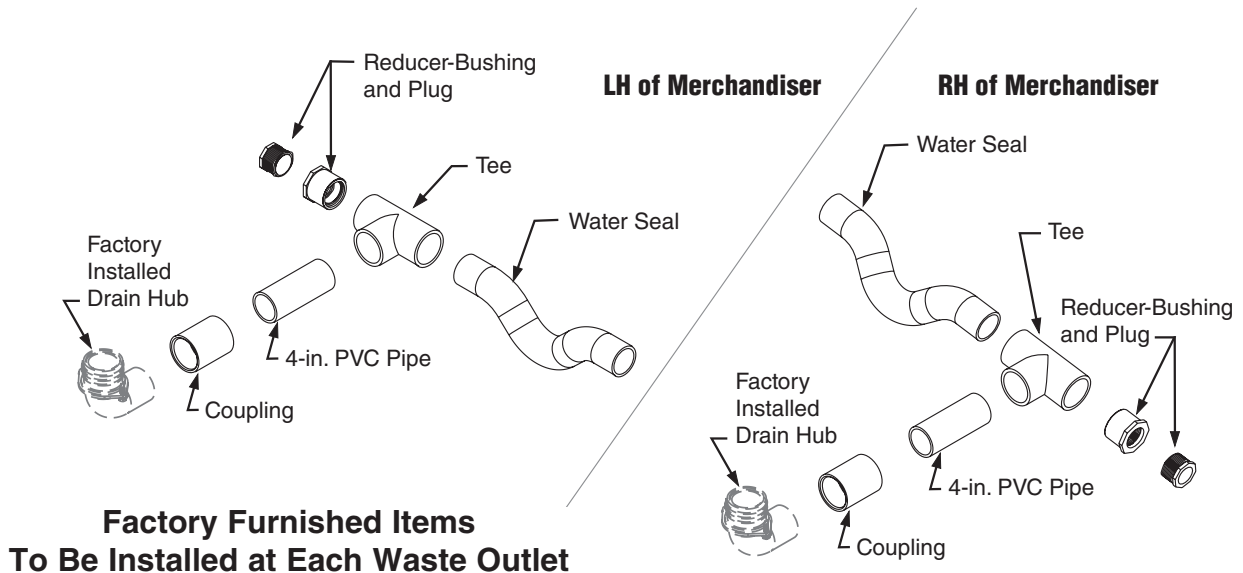

3-2 DRIP PIPING & SPLASHGUARDS

Please follow the recommendations listed below when installing drip pipes to ensure proper installation.

1. Never use drip piping smaller than the nominal diameter of the pipe or water seal supplied with the merchandiser.
2. When connecting drip piping, the “water seal” must be used as part of the drip piping to prevent air leakage or insect entrance. Never use two water seals in series in any one drip pipe. **DOUBLE WATER SEALS IN SERIES WILL CAUSE AN AIR LOCK AND PREVENT DRAINING.**
3. Pitch the drip piping in the direction of flow. **There should be a minimum pitch of 1/4 in. per ft (20 mm per 1 m).**
4. Avoid long runs of drip piping. Long runs make it impossible to provide the pitch necessary for good drainage.
5. Ensure that drip piping is supported to relieve any stress on drip pipe connectors and drain hub.

Drip piping MUST be supported no more than 24 in. from drain hub tee.

6. Provide a suitable air break between flood rim of the floor drain and outlet of drip pipe. To meet code on low base merchandisers, it may be necessary to install a field-supplied drip pipe reducer. An alternative is to cut the last section of drip pipe at an angle.
7. Prevent drip pipes from freezing:
 - a. Do NOT install drip pipes in contact with uninsulated suction lines. Suction lines should be insulated with a nonabsorbent insulation material.
 - b. Where drip pipes are located in dead air spaces, such as between merchandisers or between a merchandiser and a store wall, provide means to prevent freezing.



... ATTENTION
INSTALLER

It is the installing contractor's responsibility to consult local agencies for local code requirements.

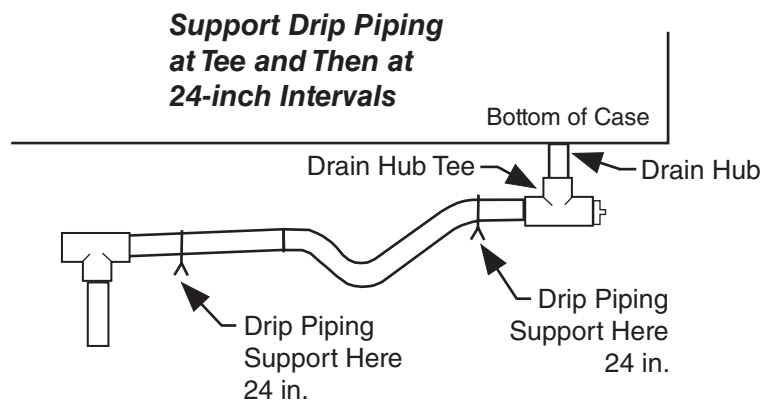

Optional Excel Service Merchandiser Drip Piping Arrangements

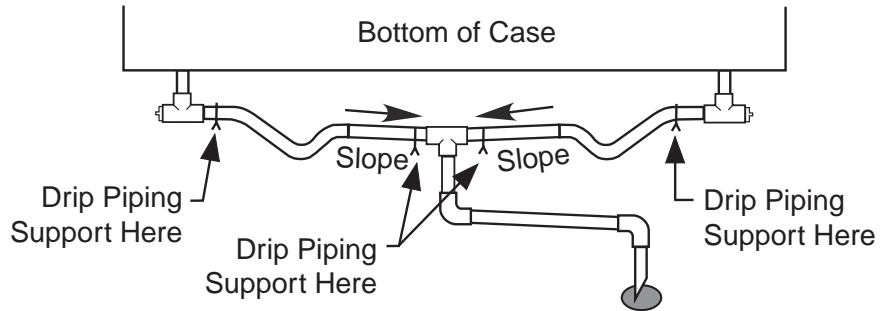

It is the installing contractor's responsibility to provide suitable drainage.

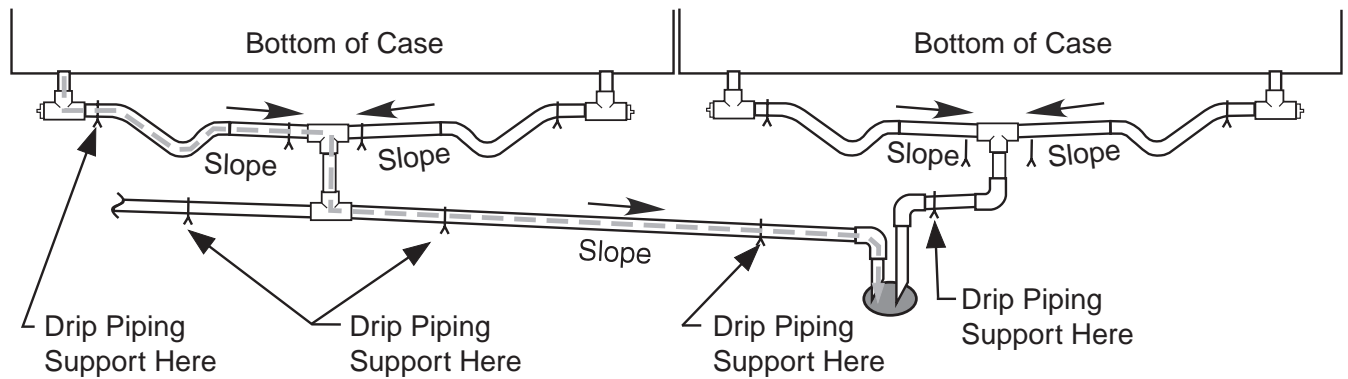

**Use only one water seal per drip pipe.
Always slope toward floor drain.**

3-4 DRIP PIPING & SPLASHGUARDS

INSTALLING SPLASHGUARD AND LOWER FRONT PANEL

Make certain that the end assemblies, end splashguards and end panels have been installed according to the End Kit instruction.

The splashguard and lower front panel are shipped inside each case. *After* merchandisers have been leveled and joined, and all drip piping, electrical and refrigeration work has been completed, install the splashguard and lower front panel.

1. At front of merchandiser, attach a splashguard retainer/bracket to each leg with sheet metal screws.
2. Position top of splashguard over the top edge of the retainer/bracket as shown below.

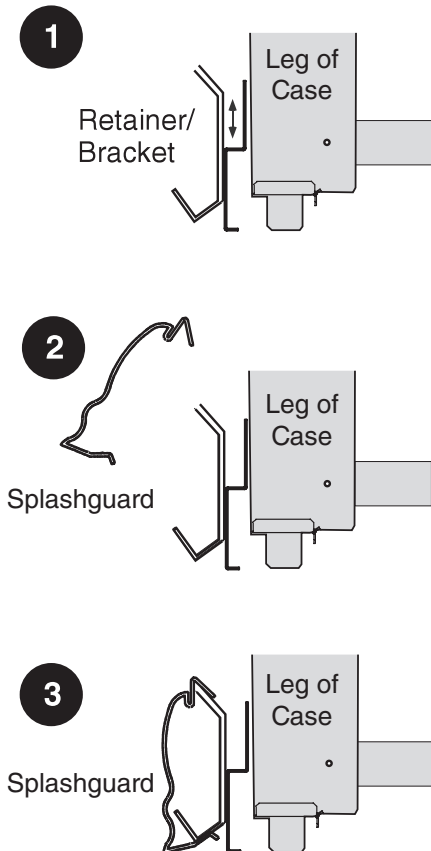

3. Push the lower edge of the splashguard toward the bottom of the bracket until it snaps into place.

To Install Lower Front Panel

1. Position the lower front panel with the top angled as shown in the illustration. Tabs extending from the upper front assembly are designed to fit into the slots on the top of the lower front panel.
2. Once the top is positioned, lift the panel up and drop it into the groove at the top of the splashguard.

Do not use additional fasteners or sealant to hold splashguards or panels in place. To meet NSF cleanability requirements, splashguards and panels must be removable without tools.

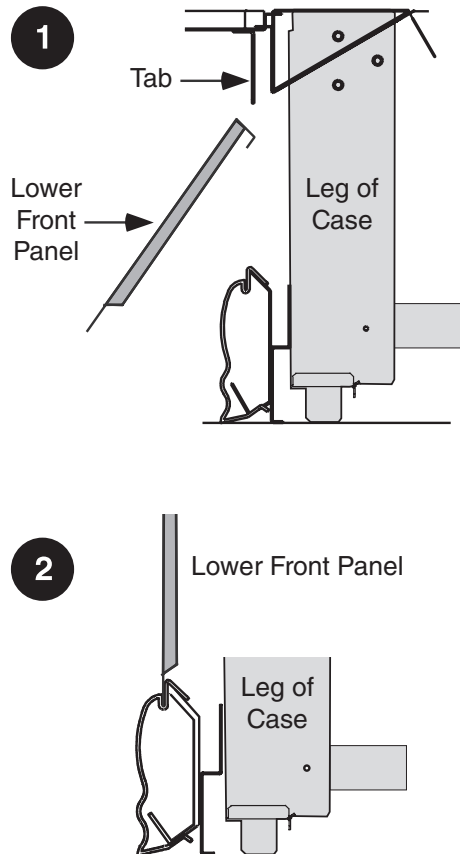

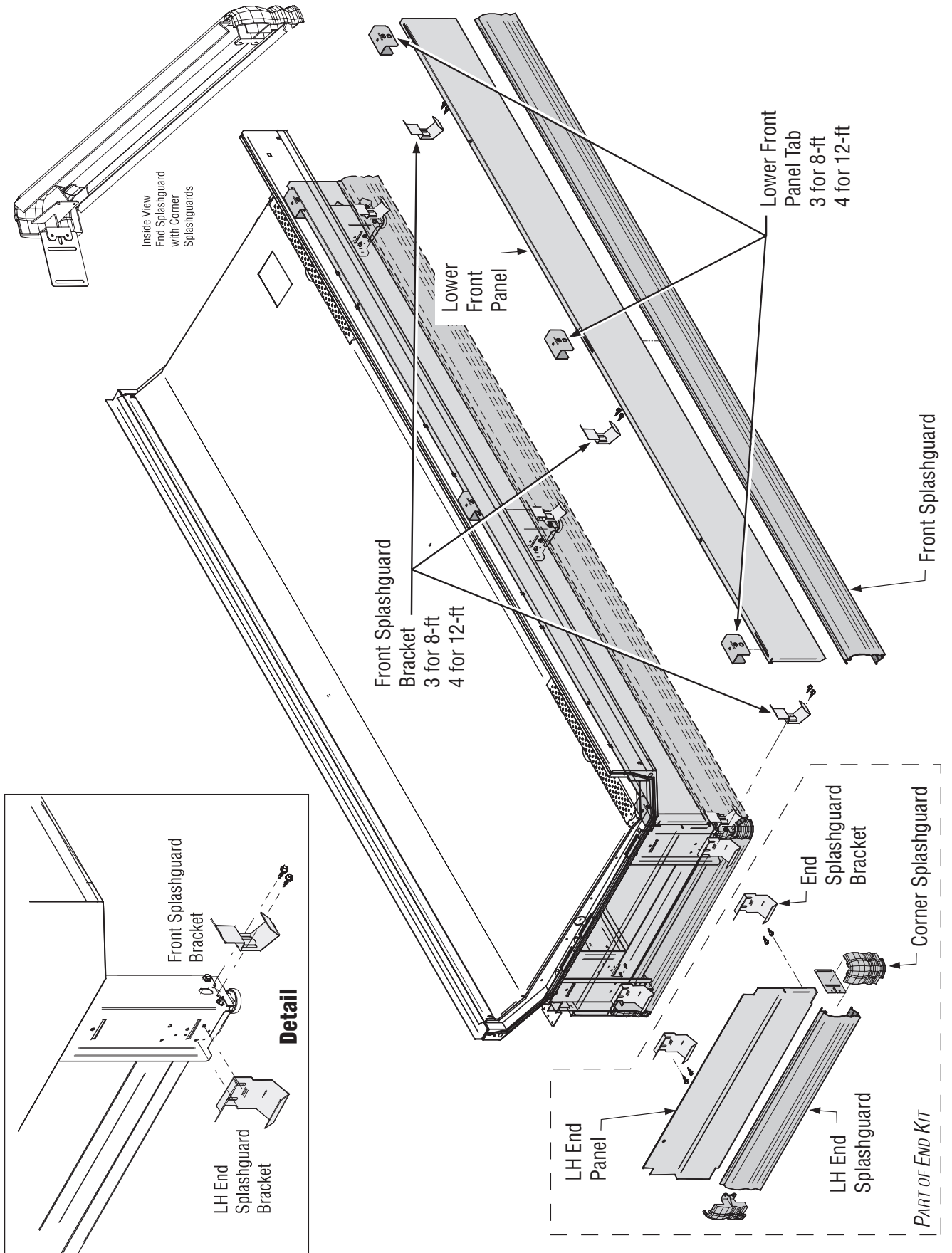

3-6 DRIP PIPING & SPLASHGUARDS

INSTALLING BOTTOM REAR PANEL

For fixed installation:

1. Attach bottom panel retainers with hex head screws.
2. Align slots in top of panel with upper retainers at each leg. Slide the panel up until it clears the bottom panel retainers.
3. Lower the panel until slots in lower edge of panel slip onto the bottom retainers.

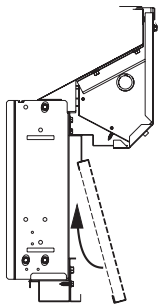

Align Top Slots
with Top Retainer

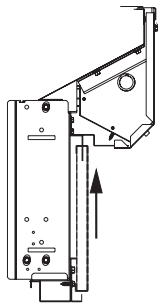

Raise Panel to Clear
Bottom Retainer

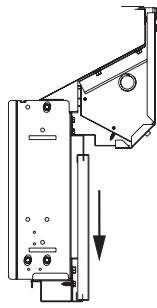

Lower Panel Over
Bottom Retainer

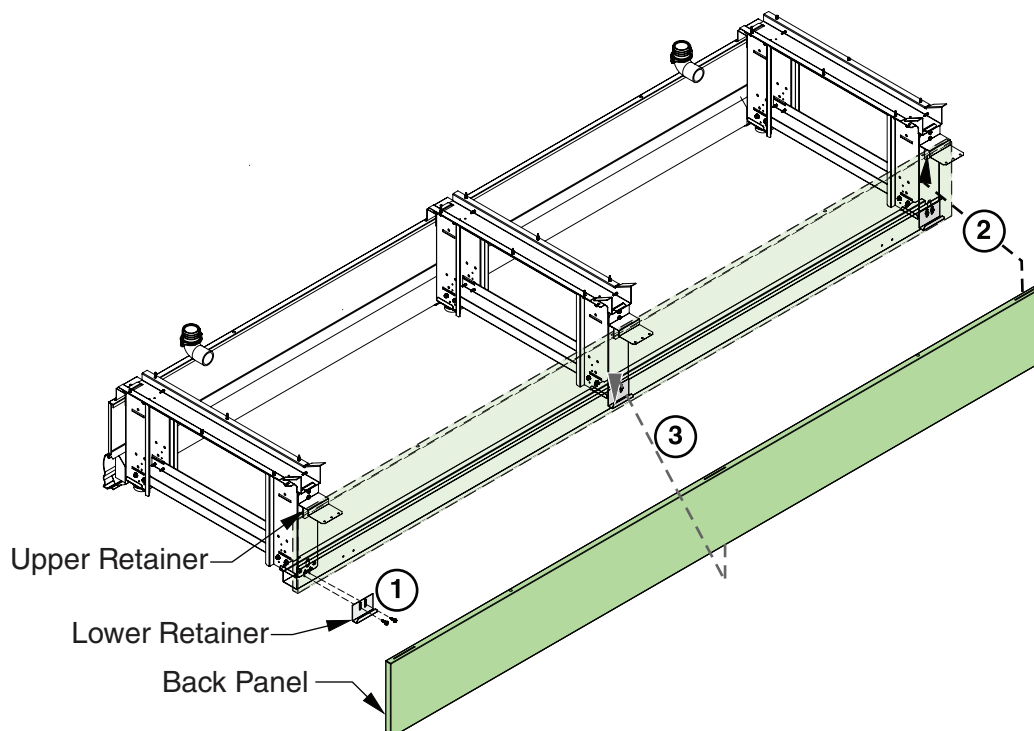

START UP / OPERATION

START UP

See the specific merchandiser's Data Sheet for refrigerant settings and defrost requirements. Bring merchandisers down to the operating temperatures listed on the data sheet.

Each 4 ft (1219 mm) section has its own evaporator coil and pre-set non-adjustable thermostatic expansion valve (TEV). No adjustment is required. **DO NOT REMOVE THE CAP ON THE TEVS.** This cap is to be removed only for valve disassembly.

| |
|---|
|  <h2 style="margin: 0;">CAUTION</h2> |
| <p>Removal of the TEV cap will result in refrigerant loss unless the system is first isolated and the refrigerant recovered.</p> |

The TEV has been factory set to provide the recommended performance settings as specified on the merchandiser data sheets.

| |
|---|
| <p>IMPORTANT!</p> <p>Ambient air curtain fans must operate at all times. Verify that these fans are working properly before starting up merchandiser.</p> |
|---|

STOCKING

Product should NOT be placed in merchandisers until case is at proper operating temperature. Proper rotation of product during stocking is necessary to prevent product loss.

AIR DISCHARGE AND RETURN FLUES MUST REMAIN OPEN AND FREE OF OBSTRUCTION AT ALL TIMES to provide proper refrigeration and air curtain performance. Do not allow product, packages, signs, etc. to block these grilles. Do not use non-approved shelving, baskets, display racks, or any accessory that could hamper air curtain performance.

SHELF MAXIMUM WEIGHT LIMITS

Hussmann merchandiser shelves are designed to support the maximum weight load limits as indicated in the table below. Exceeding these maximum weight load limits may cause damage to the shelf or shelves, damage to the merchandiser, damage to store products, and potentially create a hazardous condition for customers and staff.

Weight Limits for Merchandiser Shelving

| Nominal Shelf Depth | Maximum Load Limit |
|---------------------|--------------------|
| 7 in. (178 mm) | 75 lb (34 kg) |
| 10 in. (254 mm) | 125 lb (56.7 kg) |
| 12 in. (305 mm) | 125 lb (56.7 kg) |

*Shelf load limits at 0° tilt

Exceeding the indicated maximum weight load limits constitutes misuse as described in the Hussmann Limited Warranty.

LOAD LIMITS

Each merchandiser has a load limit decal. Recommended load limit profiles are shown on the next page. Shelf life of perishables will be short if load limit is violated. Overstocking will adversely affect product temperature and merchandiser efficiency.



DO NOT BLOCK AIR GRILLE.

| |
|---|
|  <h2 style="margin: 0;">CAUTION</h2> |
| <p>At no time should merchandisers be stocked beyond the load limits indicated. Improper stocking can cause poor performance that results in spoiled food.</p> |

LOAD LIMIT PROFILES

NOTICE

Do not put heavy objects on top of case because it could lead to structural damage.

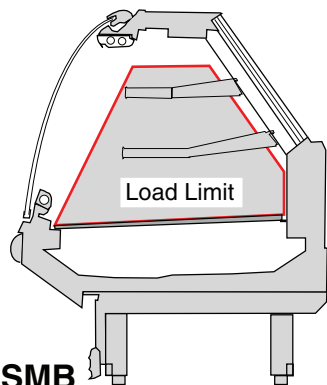
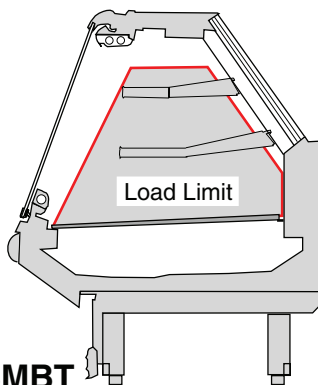
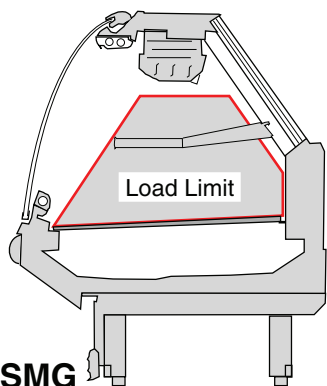
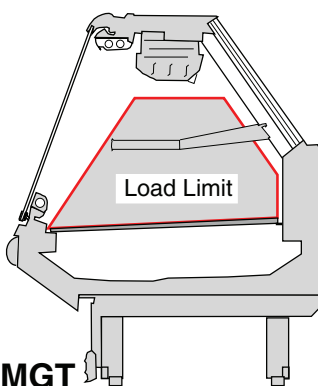
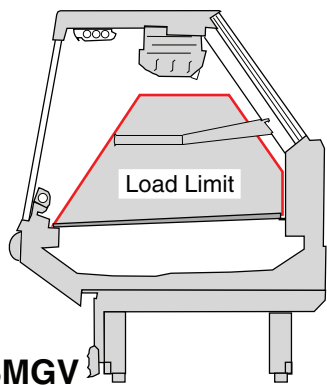
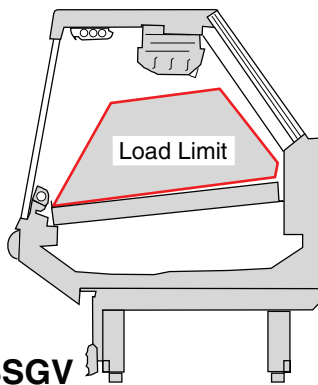
**SMB****SMBT****SMG****SMGT****SMGV****SSGV**

INSTALLING FDA/NSF REQUIRED THERMOMETER

The following pages provide the same information that ships with the thermometer.

This requirement does not apply to display refrigerators intended for bulk produce (refer to Page 1-1).

Please note that the tape cannot be exposed after installation.

This is an NSF-7 & US FDA Food Code Required Thermometer

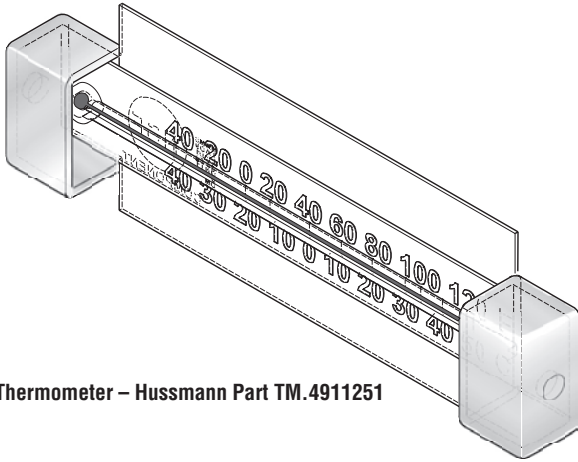

Thermometer – Hussmann Part TM.4911251

Hussmann Corporation • 12999 St. Charles Rock Road • Bridgeton, MO 63044-2483
U.S. & Canada 1-800-922-1919 • Mexico 1-800-890-2900 • www.hussmann.com
© 2007 Hussmann Corporation

Suggested Mounting Locations in Single Deck Glass Front Impact Merchandisers

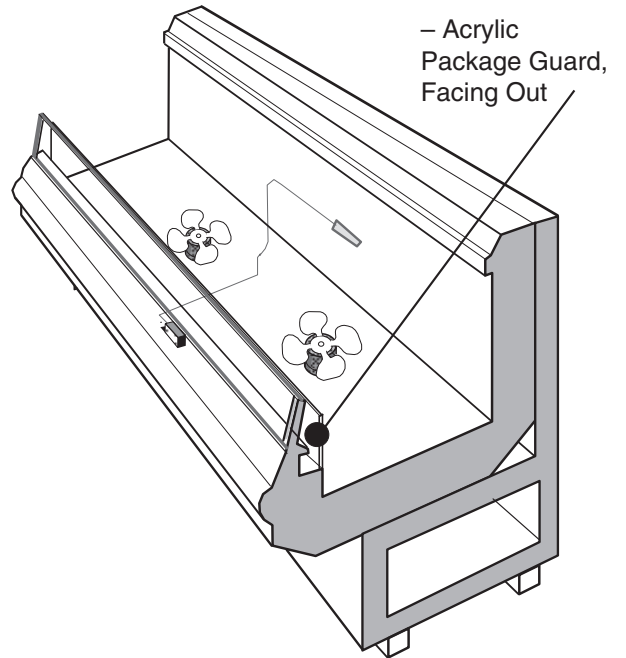

– Acrylic Package Guard, Facing Out

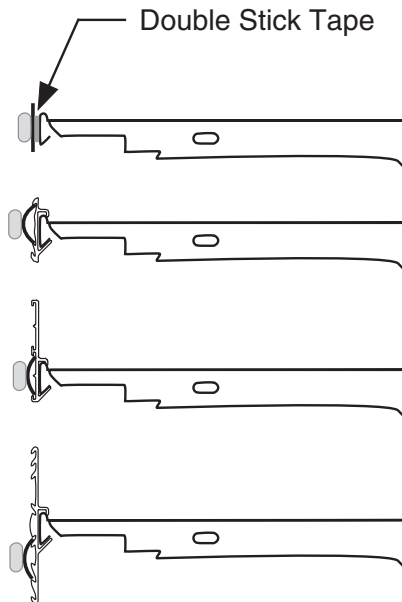

Double Stick Tape

Flexible Plastic Fits in Price Tag Moldings

– Inside End Panel

– Shelf Price Tag Molding

– Return Air Grille

Suggested Mounting Locations in Multi-deck Merchandisers

Hussmann P/N 0429971_C

10/2007

Important – Please read!

This thermometer is provided in response to United States Food and Drug Administration (US FDA) Food Code [<http://www.fda.gov/>] and National Sanitation Foundation (NSF / ANSI) Standard 7 [<http://www.nsf.org/>]

Each installation will be different depending on how the unit is stocked, shopping patterns in the department and ambient conditions of the store. The suggested locations provided herein are possible locations. It is the responsibility of the purchaser / user to determine the location with the food storage area of the unit that best meets the code requirements above.

The thermometer may need to be moved several times to find the warmest location. Mounting options include flexible plastic for price tag molding application, magnet applied to back of flexible plastic for steel end wall, and double stick tape. Tape must not be exposed after installation.

Questions about either code should be addressed to local agencies or other appropriate officials.

**Keep with merchandiser
or give to store manager.**

DO NOT DESTROY.

MAINTENANCE

CARE AND CLEANING

Long life and satisfactory performance of any equipment is dependent upon the care it receives. To ensure long life, proper sanitation and minimum maintenance costs, these merchandisers should be thoroughly cleaned, all debris removed and the interiors washed down, at least weekly.

Exterior Surfaces

The exterior surfaces must be cleaned with a mild domestic detergent and warm water to protect and maintain their attractive finish. **NEVER USE ABRASIVE CLEANERS OR SCOURING PADS. DO NOT USE AMMONIA BASED CLEANERS ON ACRYLIC PARTS.**

Interior Surfaces

The interior surfaces may be cleaned with most domestic detergents, ammonia based cleaners and sanitizing solutions with no harm to the surface. Removable parts are labeled **REMOVE FOR CLEANING**. Removable stainless steel parts may be cleaned and sanitized in dishwasher.

See next page for detailed direction.



WARNING

Product will be degraded and may spoil if allowed to sit in a non-refrigerated area.



WARNING

Do NOT use HOT water on COLD glass surfaces. This can cause the glass to shatter and could result in personal injury. Allow glass fronts, ends, and service doors to warm before applying hot water.



WARNING

ALWAYS SHUT POWER OFF DURING CLEANING PROCESS.

Do Not Use:

- Abrasive cleansers and scouring pads, as these will mar the finish.
- A hose on lighted shelves or submerge the shelves in water.
- Solvent, oil or acidic based cleaners on any interior surfaces.

Do:

- **Turn off refrigeration, then disconnect electrical power.**
- Remove the product and all loose debris to avoid clogging the waste outlet.
- Store product in a refrigerated area such as a cooler. Remove only as much product as can be taken to the cooler in a timely manner.
- Thoroughly clean all surfaces with mild detergent and water (105 to 140°F / 40 to 60°C). **DO NOT USE STEAM OR HIGH WATER PRESSURE HOSES TO WASH THE INTERIOR. THESE WILL DESTROY THE MERCHANDISER'S LINER AND SEALS CAUSING LEAKS AND POOR PERFORMANCE.**
- Lift or remove fan plenum for cleaning. Hook chain in rear panel to secure plenum during cleaning. Be sure to reposition the fan plenum after cleaning merchandiser.
- Take care to minimize direct contact between fan motors and cleaning or rinse water.
- Rinse with water, but do NOT flood. **NEVER INTRODUCE WATER FASTER THAN THE WASTE OUTLET CAN REMOVE IT.**
- Allow merchandisers to dry before resuming operation.
- After cleaning is completed, turn on power to the merchandiser.

INTERIOR CLEANING STEPS

! WARNING
Product will be degraded and may spoil if allowed to sit in a non-refrigerated area.

STEP 1 – Remove product to cooler.

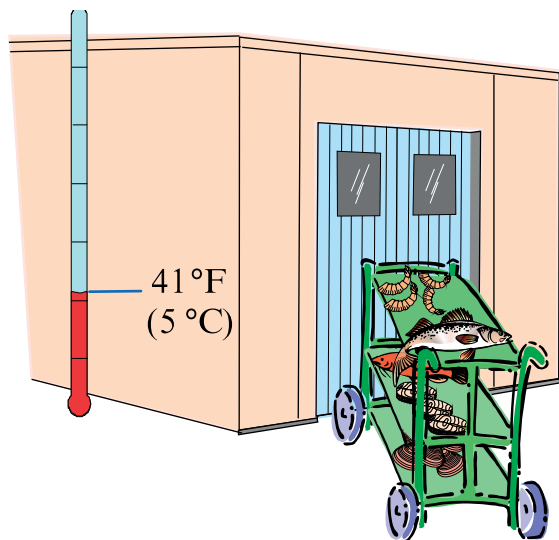

STEP 2 – Turn off refrigeration.

STEP 3 – Shut power off.

Note that refrigeration controls and power controls are not in the merchandiser. Consult the store legend or facility manager.

! WARNING
— LOCK OUT / TAG OUT —
To avoid serious injury or death from electrical shock, always disconnect the electrical power at the main disconnect when servicing or replacing any electrical component. This includes, but is not limited to, such items as doors, lights, fans, heaters and thermostats.

STEP 4 – Unplug shelves and close receptacle caps, then remove shelves.



STEP 5 – Remove display pans.



STEP 8 – Lift out interior back panel.



STEP 6 – Lift out display pan support.



STEP 9 – Lift out upper shelf supports.



STEP 7 – Lift out discharge air grille.



STEP 10 – Lift out lower shelf supports.



5-4 MAINTENANCE

STEP 11 – Lift out return air grille (from front).



STEP 12 – Rotate fan plenum up and back; hook chain at rear of liner.

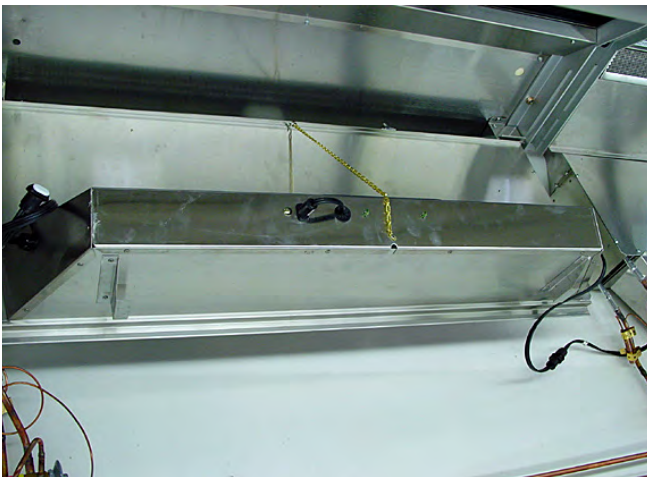

OR

Unplug fan harness.



Lift fan plenum up and back to remove. (view is from the back)

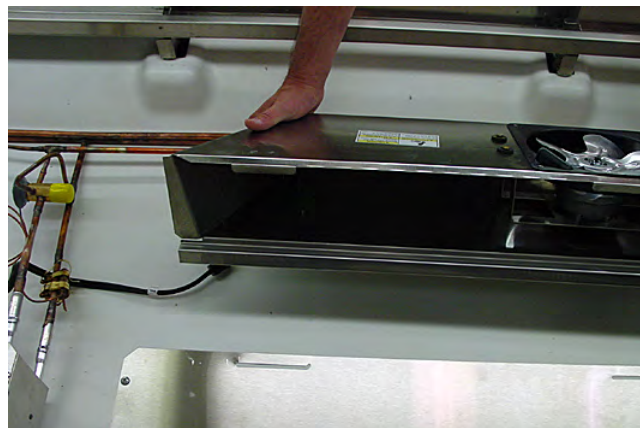
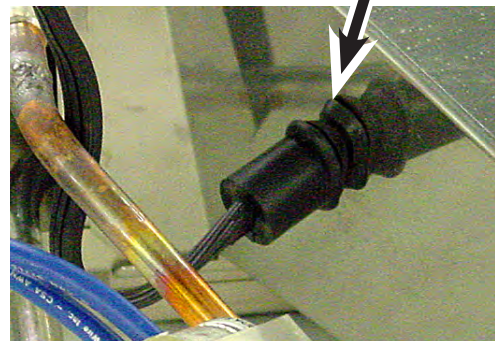

STEP 13 – Remove drip trays.

Separate lower end of flexible connector from drip tube (see page 1-4). Lift and rotate tray as necessary to clear front and back hooks.

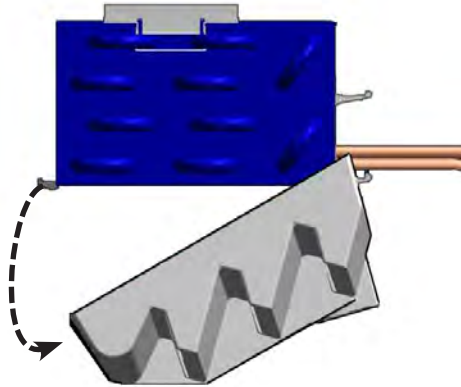

Hand wash drip trays. Sanitize drip trays and drip tubes. Use paper towels to dry inside and outside of trays before reinstalling.



STEP 14 – Clean inside the merchandiser.

Once interior parts have been removed, collect loose debris for removal. Do not clog waste outlet.



STEP 15 – Clean and sanitize according to Health Code requirements.

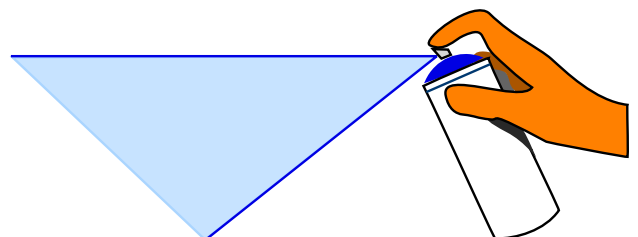
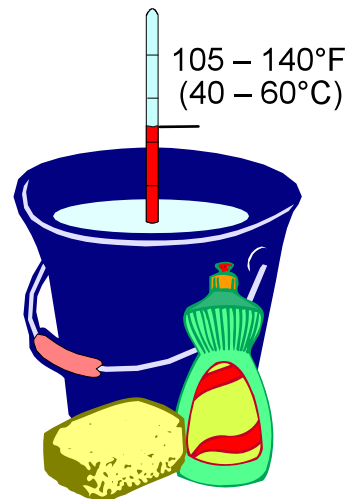

STEP 16 – Reassemble in reverse order.

Turn on power, then refrigeration. Make certain merchandiser has cooled to operating temperature before restocking.

**CLEANING ANTI-REFLECTIVE GLASS****Anti-Reflective Glass**

While the anti-reflective coatings are durable, they are susceptible to scratching if abrasive materials are used for cleaning. Once the glass surfaces are scratched, it is impossible to restore the original finish. Special care must be taken to prevent damage when cleaning the glass.

Anti-reflective glass can be cleaned with clear water or any non-alkaline detergent. However, it is very important to use a soft cloth, a micro-fiber cleaning cloth or a wet sponge.

NEVER USE the following types of materials to clean glass with anti-reflective coatings:

- Coarse Paper Towels
- Scouring Pads or Powders
- Steel Wool or Steel Fiber Materials
- Blades
- Acidic or highly Alkaline detergents
- Fluorine based detergents

CLEANING STAINLESS STEEL SURFACES

Use non-abrasive cleaning materials, and always polish with grain of the steel. Use warm water or add a mild detergent to the water and apply with a cloth. Always wipe rails dry after wetting.

Use alkaline chlorinated or non-chlorine containing cleaners such as window cleaners and mild detergents. Do not use cleaners containing salts as this may cause pitting and rusting of the stainless steel finish. Do not use bleach. Clean frequently to avoid build-up of hard, stubborn stains. A stainless steel cleaning solution may be used periodically to minimize scratching and remove stains.

Rinse and wipe dry immediately after cleaning. Never use hydrochloric acid (muriatic acid) on stainless steel.

CLEANING COILS

Never use sharp objects around coils. Use a soft brush or vacuum brush to clean debris from coils.

Do not puncture coils!

Do not bend fins. Contact an authorized service technician if a coil is punctured, cracked, or otherwise damaged.

Do NOT use chlorine or ammonia-based cleaners to clean aluminum coils.

ICE in or on the coil indicates the refrigeration and defrost cycle is not operating properly. Contact an authorized service technician to determine the cause of icing, and to make adjustments as necessary. To maintain product integrity, move all product to a cooler until the unit has returned to normal operating temperatures.

MAINTAINING FLUORESCENT LAMPS

Fluorescent lamps should not be allowed to run to failure. If a re-lamp schedule is not in place, the tubes should be inspected for signs of degradation (blackened ends). Degraded or failed tubes should be replaced.

Allowing severely degraded lamps to operate may cause a ballast failure or could expose the lamp holder to excessive heat. Replacing degraded bulbs is more cost effective than replacing ballast and lamp-holders.

Traditional re-lamp programs are 18- to 24-month intervals. In the absence of a re-lamp program, a yearly inspection of the lightning system is recommended.

1. Inspect all lamp sockets and plug-receptacle connections for signs of arcing. Replace any component that shows signs of arcing.
2. Make sure all unused receptacles have their close-off covers securely installed.
3. Make sure proper cleaning procedures are followed. Lights and fans **MUST** be turned off when a case is cleaned and **MUST** be allowed to dry before turning power back on.
4. Do not use a pressure nozzle to clean inside a case.

REMOVING SCRATCHES FROM BUMPER

Most scratches and dings can be removed using the following procedure.

1. Use steel wool to smooth out the surface area of the bumper.
2. Clean area.
3. Apply vinyl or car wax and polish surface for a smooth glossy finish.

5-8 MAINTENANCE

Notes:

SERVICE

REPLACING FAN MOTORS AND BLADES

See cross section for location of evaporator fans. Should it ever be necessary to service or replace the fan motors or blades be certain that the fan blades are re-installed correctly. **THE BLADES MUST BE INSTALLED WITH RAISED EMBOSING (PART NUMBER ON PLASTIC BLADES) POSITIONED AS INDICATED ON THE PARTS LIST.** (Refer to the case data sheet for each model.)

For access to evaporator fans:

1. Turn off power.
2. Remove bottom display pans.
3. **Disconnect fan from wiring harness.**
4. Lift fan plenum out of case. Place on stable work surface.
5. Remove screws holding fan basket to plenum. Fan blade may be removed after fan assembly is removed from plenum.
6. Remove screws holding bottom of motor to fan basket.
7. Replace fan motor and blade in fan basket.
8. Reinstall fan basket in plenum and reinstall plenum in case.
9. Reconnect fan to wiring harness. Turn power on.
10. Verify that motor is working and blade is turning in the correct direction.

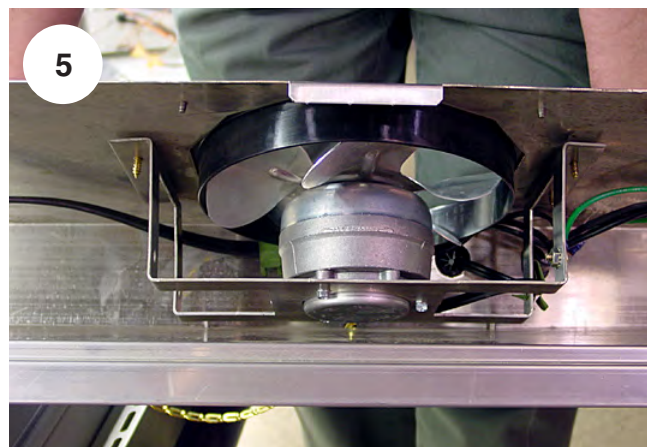
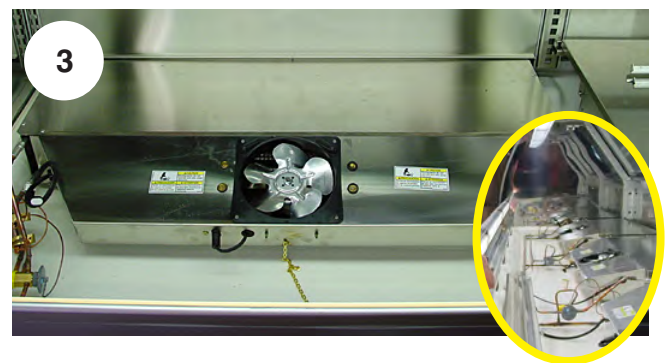
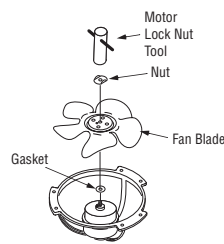

6-2 SERVICE

For access to ambient fans:

1. Turn off power.
2. Remove lower front panel.
3. Disconnect fan from wiring harness.
4. Remove screws holding motor and grille.
5. Replace fan motor and grille.
6. Reconnect fan to wiring harness. Turn power on.
7. Verify that motor is working and blade is turning in the correct direction.
8. Replace lower front panel.



REMOVING POLYCARBONATE LAMP COVERS

The canopy and rail covers are removed without tools. Apply pressure as shown in the photos until the cover clears the retainer, then pivot out of the retainer. Reinstall in reverse order.

Canopy Fixture

From the front of the case, grasp the cover with both hands. Pull forward until the back of the cover clears the retainer, then rotate down and out.



Rail Fixture

From the front of the case, grasp the cover with both hands. Pull forward and up until the back of the cover clears the retainer.

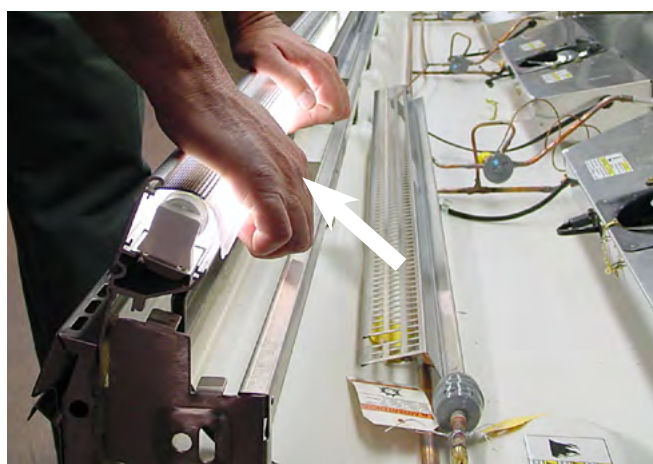

ELECTRICAL SERVICE RECEPTACLES

The receptacles located on the exterior back of the merchandisers are intended for scales and other light duty appliances that are found in meat and delicatessen departments. The receptacles are not intended for large motors.

REPLACING FLUORESCENT LAMPS

Fluorescent lamps are furnished with moisture resistant lamp holders and end caps. Lamps on lighted shelves have plastic shields. Whenever a fluorescent lamp is replaced, be certain to reinstall the plastic shields and end caps.

Inspect all lamp sockets and plug-receptacle connections for signs of arcing. Replace any component that shows signs of arcing.

Make sure all unused receptacles have their close-off covers securely attached.

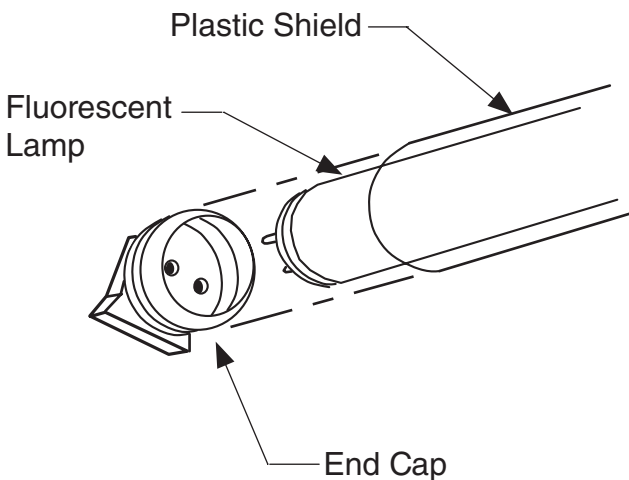

IMPORTANT!

Always replace lamp holders and end caps with Hussmann lamp holders and end caps.

Use of non-Hussmann parts may result in poor electrical contact and short lamp life.

REPLACING LAMP HOLDERS AND END CAPS

The Hussmann lamp holder is designed to snap into the sheet metal of the case. The lamp holder has a locking 'nub' which fits inside the groove of specially designed end caps.

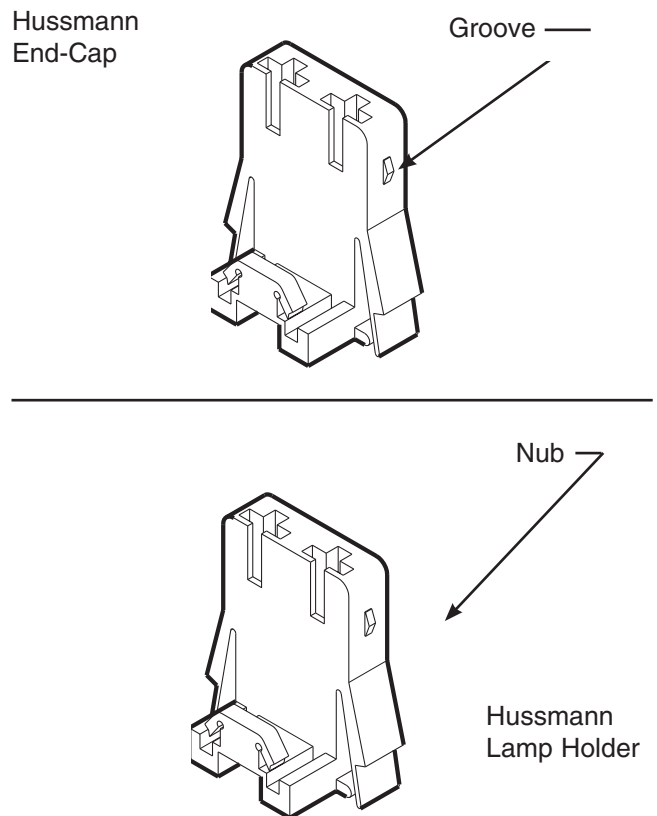

! CAUTION

Fluorescent lamps contain mercury vapor. Mercury exposure at high levels can harm the brain, heart, kidneys, lungs, and immune system of people of all ages. Do not break or puncture fluorescent lamps. Dispose of, or store, all fluorescent lamps in accordance with Federal (40 CFR 273), State, and local hazardous waste requirements. Refer to <http://www.epa.gov/mercury/about.htm>

REPLACING ELECTRONIC BALLAST

Lamp Ballast

The lamp ballast are located in the raceway, behind the back lower panel at the left-hand end of the merchandiser (facing rear of case).
 NOTE: The switch for the lamp is located in this panel.

To gain access:

1. Disconnect the electrical power to the merchandiser.
2. Remove the left lower rear panel.
3. Service or replace ballast as required. Reassemble items as they were originally installed.
4. Reconnect the electrical power.

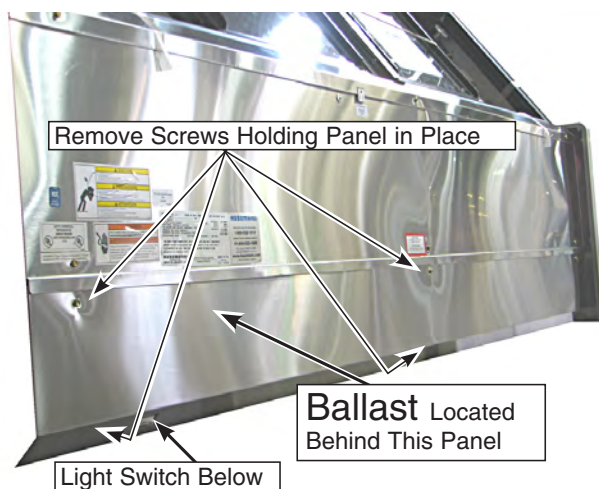

REPLACING LEDs

Locate the LED lamp to be replaced. Always replace with like fixtures. Contact your Hussmann representative for ordering information. All LED fixtures attach using mounting clips and screw.

NOTE:

One power supply can provide power for as many as 10 shelf lights.

Plug the quick-connect plugs into the shelf receptacles at the back of the merchandiser.

Use a tie wrap to contain any excess plug wire. Do not allow wire to lie on product or hang loose.

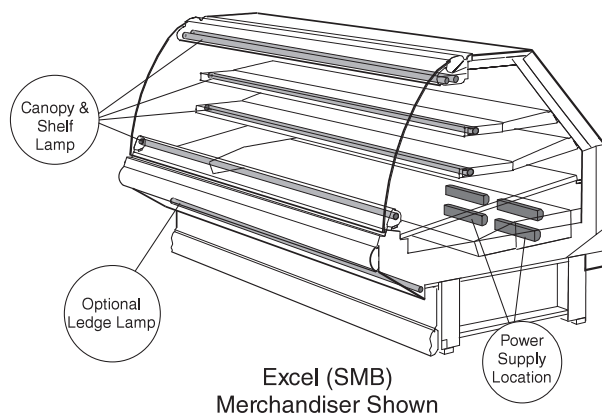
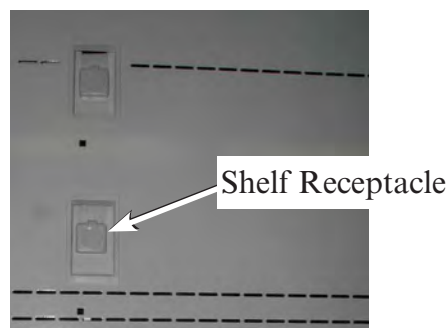

**REPLACING CYLINDERS —
SINGLE PANE GLASS**

! CAUTION

Check each glass section monthly to determine if support cylinders are worn and need to be replaced. If the glass does not stay in a raised position, have the cylinders replaced.

Each front curved glass section weighs about 40 lb (18 kg). To prevent glass from falling during installation, use or maintenance and causing injury to customers or personnel, Hussmann recommends one person hold the glass in a raised position while the other person performs cylinder replacement. Support the front glass at all times until cylinder is replaced or the glass is lowered.

NOTICE

Cylinders are a wear item. They are designed:

- to support the glass when fully open.
- to allow the glass to come down (or close) slowly.

Have your Service Contractor replace the cylinders when required.

When cylinders need to be replaced, the lifting force of the cylinder must be known. The lifting force can be determined by the data printed on the cylinder being replaced. The following shows the part number for the 300N and 400N cylinders.

- 300N Cylinder – P/N 0412539
- 400N Cylinder – P/N 0406925

1. Raise the front glass to open completely.
2. Use special hand tool, shown in photo, to compress and remove cylinder.

Note: Cylinders cannot be removed without special hand tool.

Cylinder Removal Tool

P/N 0425326

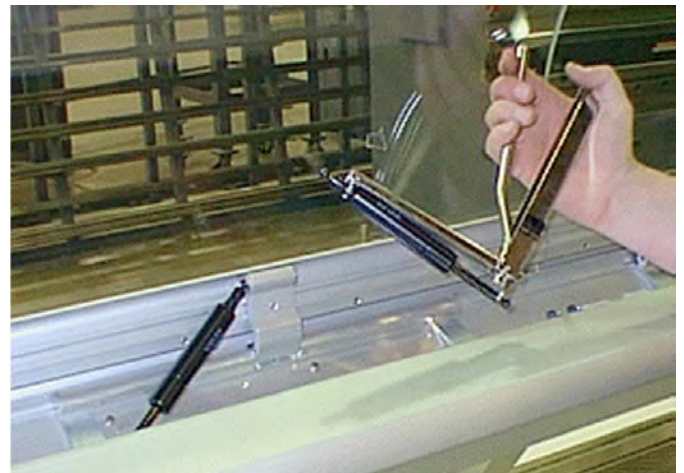

Removing a Cylinder

NOTICE

Cylinder rods must point down so oil will lubricate the rod and seals. Failure to lubricate will severely shorten cylinder life.

REPLACING SINGLE PANE FRONT GLASS (Requires more than one person.)

⚠ WARNING

Once set screws are loose, the glass and glass clamp have NO support or retainers. Support the front glass at all times until the top glass clamp and set screws are secured, or glass is removed.

1. Raise the front glass to open completely.
2. Loosen all set screws along the inside bottom of the glass clamp.

Note: All cylinders do not have to be removed to remove the glass.

IMPORTANT

When reinstalling glass, be certain that:

1. Gasket is on glass evenly.
2. Glass bottom is fully in retainer.
3. When set screws are tightened, glass is firmly held in place by the glass clamps.

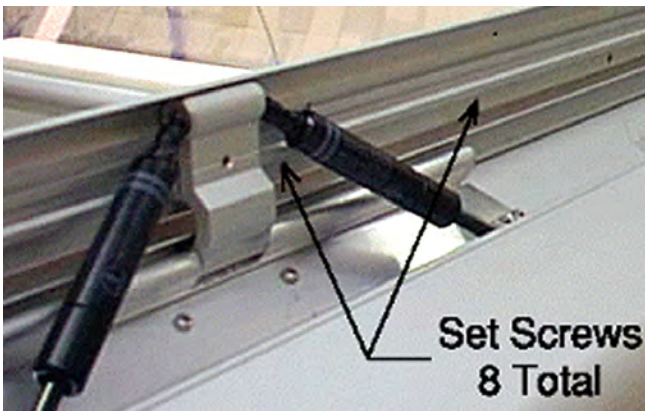

Set Screw Locations

Apply a drop of Loctite 242 or equivalent threading locking fluid onto each set screw of the glass clamp assembly. Tighten all screws with a TORX T15 bit.

IMPORTANT: Tighten all glass clamp set screws to 26 inch lbs. Verify bit is in good condition and not worn out. When set screws are tightened, glass is firmly held in place by glass clamps.

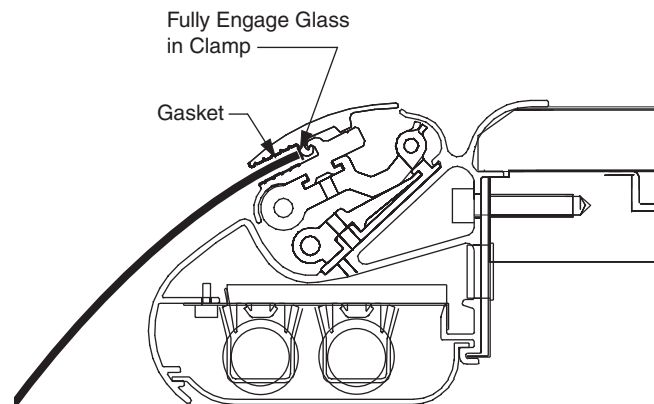
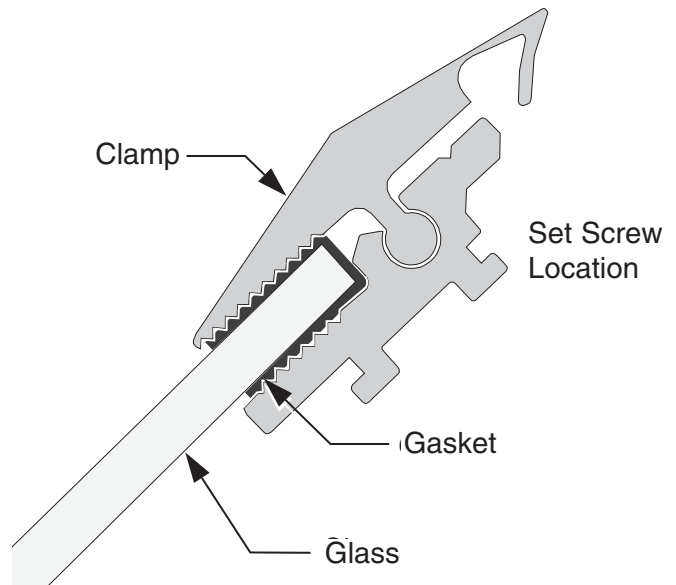

REPLACING GLASS HAND GRIP

The hand grip is fastened to the curved glass as shown below. A 2 inch (51 mm) bead of silicone needs to be placed 3 inches (76 mm) from each end and in the center of the hand grip. The duct tape is placed on the glass to provide a tight fit.

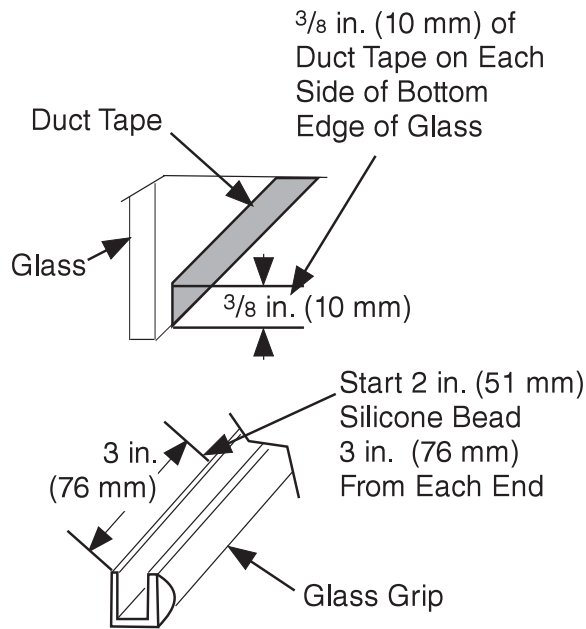

HINGE HARDWARE

Type: Two cylinders and one fastening point.

P/N 0401884

Used on: 8 ft and 12 ft (2438 mm and 3658 mm) parent cases and as a joining bracket.

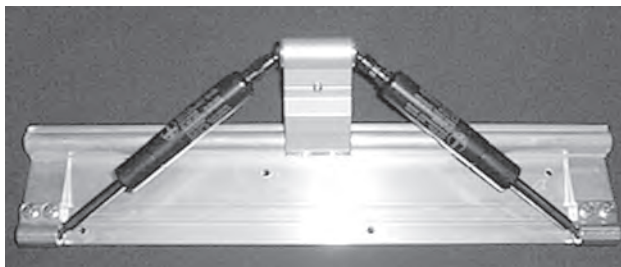

Type: Two cylinders and three fastening points.

P/N 0407352

Used on: 30° outside wedge.

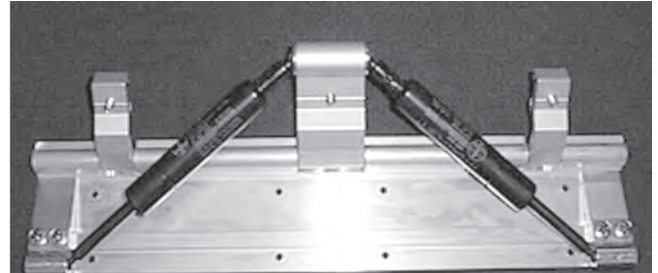

Type: Three cylinders and four fastening points.

P/N 0412538

Used on 90° inside wedge, 45° outside and inside wedge, 30° inside wedge.

Note: This hinge assembly, when used on the 90° and 45° inside wedge, uses only two cylinders.

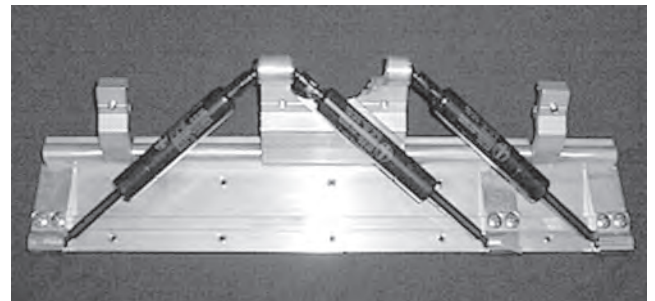

Type: Four cylinders and five fastening points.

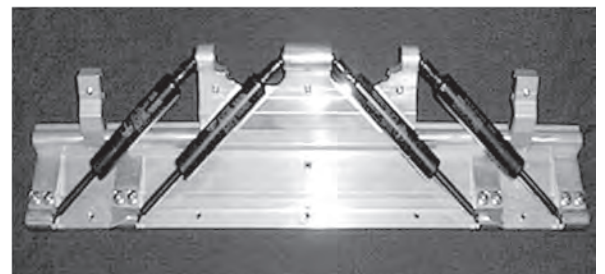

P/N 0413170

Used On: 90° outside wedge.

REPAIRING ALUMINUM COIL

The aluminum coils used in Hussmann merchandisers may be easily repaired in the field. Materials are available from local refrigeration wholesalers.

Hussmann recommends the following solders and technique:

Solders

Aladdin Welding Products Inc.

P.O. Box 7188

1300 Burton St.

Grand Rapids, MI 49507

Phone: 1-800-645-3413

Fax: 1-800-645-3414

X-Ergon

1570 E. Northgate

P.O. Box 2102

Irving, TX 75062

Phone: 1-800-527-9916

NOTE:

Hussmann Aluminum melts at 1125°F (607°C)

Aladdin 3-in-1 rod at 732°F (389°C)

X-Ergon Acid core at 455°F (235°C)

Technique:

1. Locate leak.
2. REMOVE ALL PRESSURE.
3. Brush area UNDER HEAT.
4. Use PRESTOLITE TORCH ONLY.
Number 6 tip.
5. Maintain separate set of stainless steel brushes, and USE ONLY ON ALUMINUM.
6. Tin surface around area.
7. Brush tinned surface UNDER HEAT, thoroughly filling the open pores around leak.
8. Repair leak. Let aluminum melt solder, NOT the torch.
9. Don't repair for looks. Go for thickness.
10. Perform a leak check.
11. Wash with water.
12. Cover with a good flexible sealant.



WARNING

Refrigerant vapor is hazardous to your health and can cause death.

Avoid breathing refrigerant and lubrication vapor or mist. Exposure may irritate eyes, nose and throat. If accidental system discharge occurs, ventilate work area before resuming service.

Always wear safety goggles and protective gloves when working with refrigerants. Contact with refrigerant may cause injury. Disconnect hoses with extreme caution! All hoses may contain liquid refrigerant under pressure.

Be sure that any room where you are working is thoroughly ventilated, especially if a leak is suspected.

Read all safety information regarding the safe handling of refrigerant and refrigerant oil, including the Material Safety Data Sheet. MSDS sheets can be obtained from your refrigerant supplier.

Refrigeration lines are under pressure and should be depressurized before attempting to make any connections.

When brazing pipes, be sure to use the insulation blanket shipped with the merchandiser to prevent fire or damage to the plastic case bottom.

HUSSMANN[®]

To obtain warranty information
or other support, contact your Hussmann
representative.

Please include the model and
serial number of the product.

Husmann Corporation

12999 St. Charles Rock Road
Bridgeton, MO 63044-2483
www.husmann.com