



SERVICE CAKE
HUSSMANN - SGB (CHINO)

REVISION DATE 04/28/17



Hussmann refrigerated merchandisers configured for sale for use in the United States meet or surpass the requirements of the DOE 2017 energy efficiency standards.

SGB Service Bakery Straight Glass

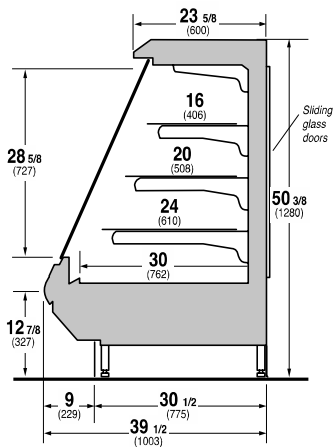

SGB Plan View

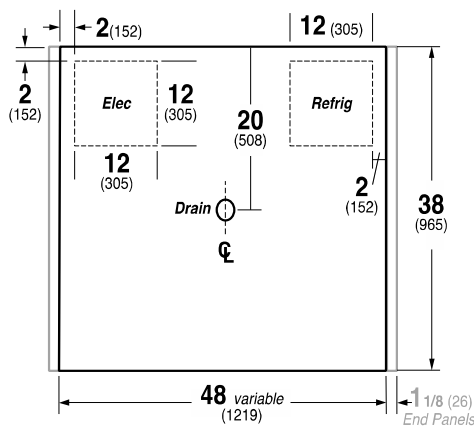

REFRIGERATION DATA:

CASE LENGTHS (INCHES)	CASE USAGE	CAPACITY *** (BTU/HR/FT)		TEMPERATURE (°F)			VELOCITY (FT/MIN)
		RATING CONDITION		EVAPORATOR		DISCHARGE AIR ** (°F)	
		NSF 7	AHRI 1200	NSF 7	AHRI 1200	NSF 7	
48, 57.5, 75.5, 96	BAKERY	535	490	20	22	26~28	300~350

CASE LENGTHS	EST. REFG. CHR.G. 404A (LBS)	20°F GLYCOL 6° RISE	
		GPM	PSI
48"	0.5	0.8	2.3
57.5"	0.7	1.0	3.5
75.5"	0.9	1.2	1.6
96"	1.1	1.5	1.7

**FRONT DISCHARGE AIR MEASURED INSIDE AIR CURTAIN HONEYCOMB

***REFRIGERATION NOTES:

- 1) BTU'S INCLUDE CANOPY LIGHTS. ADD 10 BTUS/SHELF/FT FOR EACH SHELF (LIGHT)
- 2) AHRI 1200 RATING POINT FOR ENERGY CONSUMPTION COMPARISON ONLY
- 3) USE DEW POINT FOR HIGH GLIDE REFRIGERANTS. CARE SHOULD BE TAKEN TO USE THE DEW POINT IN P/T TABLES FOR MEASURING AND ADJUSTING SUPERHEAT. ADJUST EVAPORATOR PRESSURE AS NEEDED TO MAINTAIN THE DISCHARGE AIR TEMPERATURE SHOWN.
- 4) RATING CONDITION IS NSF TYPE I, 75°F/55% RH

REFRIGERATION DATA CONTINUED:

ELEC. THERMOSTAT / AIR SENSOR SETTINGS			DEFROST TYPE	TIME (MIN)	DEFROST FREQUENCY (#/DAY)	TERM. TEMP (°F) COIL ONLY	DRIP TIME	DEFROST WATER (LBS/DAY/FT)
USAGE	CUT IN (°F)	CUT OUT (°F)						
BAKERY	28	25	OFF TIME	30	6	45	N/A	2.5

END PANEL WIDTH KEY		
# OF END PNLS	END PNL WIDTH (IN.)	TOTAL ADDED LENGTH (IN.)
1	1.125	1.125
2	1.125	2.25

ELECTRICAL DATA:

STANDARD FANS, LED LIGHTS (115 VOLT)

CASE LENGTH	EVAPORATOR FANS					AIRSWEEP FANS			CANOPY LIGHTS LED		OPTIONAL LED SHELF LIGHTS		MAX. LED LOAD (W/ ALL OPTIONS)	
	# OF EVAP FANS	BLADE DIA. (IN.)	BLADE PITCH	AMPS	WATTS	# OF FANS	AMPS	WATTS	AMPS	WATTS	AMPS	WATTS	AMPS	WATTS
48"	3	4	N/A	0.12	14	2	0.08	9	0.07	8	0.27	31	0.34	39
57.5"	3	4	N/A	0.12	14	2	0.08	9	0.09	10	0.27	31	0.36	41
75.5"	4	4	N/A	0.16	19	2	0.08	9	0.11	13	0.40	46	0.51	59
96"	6	4	N/A	0.25	28	4	0.16	19	0.13	15	0.54	62	0.67	77

OPTIONAL HIGH OUTPUT LED LIGHTS (115 VOLT)

CASE LENGTH	CANOPY LIGHTS H.O. LED		OPTIONAL SHELF		MAX. H.O. LED LOAD	
	AMPS	WATTS	AMPS	WATTS	AMPS	WATTS
48"	N/A	N/A	N/A	N/A	N/A	N/A
57.5"	N/A	N/A	N/A	N/A	N/A	N/A
75.5"	N/A	N/A	N/A	N/A	N/A	N/A
96"	N/A	N/A	N/A	N/A	N/A	N/A

STANDARD HEATERS, OPTIONAL OUTLETS

ANTI-SWEAT HEATERS (ON FAN CIRCUIT)		CONVENIENCE OUTLETS (OPTIONAL)		
AMPS	WATTS	# OUTLET	VOLTS	AMPS
1.04	120	1	115	15
1.07	123	1	115	15
1.43	165	1	115	15
2.09	240	1	115	15