

We reserve the right to change or revise specifications and product design in connection with any feature of our products. Such changes do not entitle the buyer to corresponding changes, improvements, additions or replacements for equipment previously sold or shipped.

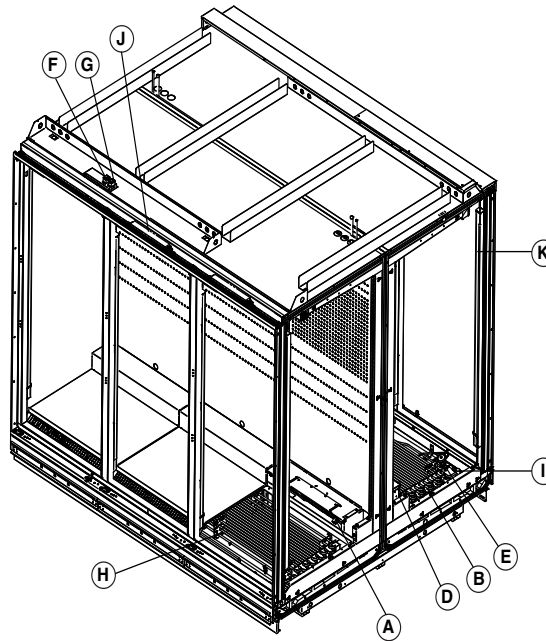

**DOE 2017**  
Energy Efficiency  
Compliant

**Warning:**  
Terminal block **NOT** for  
case-to-case  
wire connection!

Refrigeration and  
electrical connections  
are on top. Overhead  
piping and electrical  
circuits are required.

Item	Part #	Description	Wiring Item #	Item	Part #	Description	Wiring Item #
<b>FAN ASSEMBLIES AND THERMOSTATS</b>				<b>LED FIXTURES AND POWER SUPPLY</b>			
A.	Fan Assembly		(1)	<i>Innovator Doors Standard</i>			
	0527610	Standard Energy Efficient Motor		J.	0499399	Power Supply	
	0461805	Fan Blade		K.		LED Fixture	
B.	0547083	Standard Non-adjustable Defrost Thermostat	(2)	<i>Replace with like fixtures</i>			
C.		Opt. Adj. Refrigeration Thermostat	(3)				
D.	0440423	Defrost Limit Thermostat	(4)				
E.	0547090	Relay Control Thermostat or Fan and Anti-sweat Heater Thermostat (CT.4440353) (KG Only)	(5)				
<b>RELAYS</b>							
F.	0342598	Anti-Sweat Control Relay (120V Koolgas)	(6)				
G.	0342599	Fan Control Relay (208V)	(7)				
<b>HEATERS</b>							
H.	Electric Defrost Heaters (208V)		(8)				
	3015384	(2) 2 Door Models					
	3015385	(2) 3 Door Models					
	3015386	(2) 4 Door Models					
	3015387	(2) 5 Door Models					
I.	Drain Pan Heater Electric & Koolgas (120V)		(9)				
	0452974	(2) 2 Door Models					
	0452975	(2) 3 Door Models					
	0452976	(2) 4 Door Models					
	0452977	(2) 5 Door Models					

**Refer to INNOVATOR REACH-IN GLASS DOOR INSTALLATION AND SERVICE manual, PIN 0425683, for Innovator, Innovator I LE, or Innovator III door and frame replacement parts.**

Data sheet-Reach-in RLTIM

Note: Revision H: Updated wiring diagrams on page 6 and 7.

# Engineering Plan Views

## RLTIM Plan View 2, 3, 4, & 5 Door

Dimensions shown as in. & (mm).

### PHYSICAL DATA

Merchandiser Drip Pipe (in.)	1
Merchandiser Liquid Line (in.)	3/8
Merchandiser Suction Line (in.)	5/8

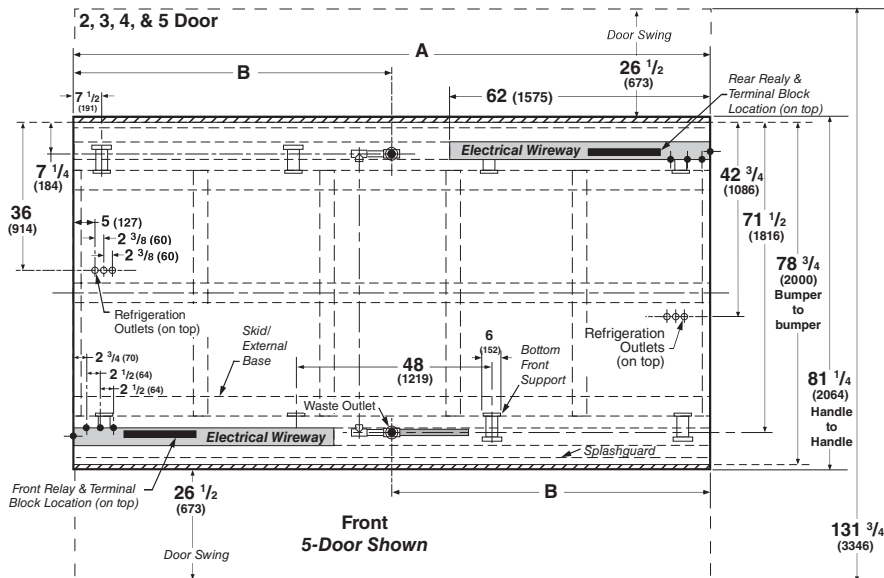

**Refrigeration and electrical connections are on top. Overhead piping and electrical circuits are required.**

<b>Serial Plate attached to top left front of each case.</b>	<b>2 Dr</b>	<b>3 Dr</b>	<b>4 Dr</b>	<b>5 Dr</b>
<b>General</b>				
<b>(A) Case Length (without ends or partitions)</b>	62 (1575)	92 1/2 (2350)	122 7/8 (3121)	153 3/8 (3896)
<b>**NOTE:</b> Each solid end adds approximately 2 3/8 in (60 mm) to length of line up; each partition add approximately 2 3/4 in (70 mm); case to case joints can add approximately 1/8 in (3 mm) for gasket material.				
Maximum O/S dimension of case back to front <i>(Includes bumpers and handles)</i>	81 1/4 (2064)	81 1/4 (2064)	81 1/4 (2064)	81 1/4 (2064)
Back of case to rear of splashguard	74 7/8 (1902)	74 7/8 (1902)	74 7/8 (1902)	74 7/8 (1902)
Width of Skid rail	3 3/8 (86)	3 3/8 (86)	3 3/8 (86)	3 3/8 (86)
Width of Bottom Front Support	6 (152)	6 (152)	6 (152)	6 (152)
Stub-up area between front skid rail and splashguard	7 5/8 (194)	7 5/8 (194)	7 5/8 (194)	7 5/8 (194)
<b>Electrical Service</b>				
Left hand end of case to the center of nearest knockout	2 3/4 (70)	2 3/4 (70)	2 3/4 (70)	2 3/4 (70)
Right hand end of case to the center of center knockout	56 3/4 (1441)	87 1/4 (2216)	117 5/8 (2988)	148 1/8 (3762)
Back O/S of case to center of front knockout	68 3/8 (1737)	68 3/8 (1737)	68 3/8 (1737)	68 3/8 (1737)
Back O/S of case to center of rear knockout	10 3/8 (264)	10 3/8 (264)	10 3/8 (264)	10 3/8 (264)
<b>* NOTE:</b> Electrical Field Wiring Connection Point is at terminal. Front and rear are wired separately.				
<b>Waste Outlet</b>				
<b>(B) Right end of case to center of waste outlet</b>	23 7/8 (606)	54 1/4 (1378)	46 1/4 (1175)	76 5/8 (1946)
Back O/S of case to center of waste outlet	71 1/2 (1816)	71 1/2 (1816)	71 1/2 (1816)	71 1/2 (1816)
<b>Water Seal</b>				
Edge of water seal to center of waste outlet	13 (330)	13 (330)	13 (330)	13 (330)
Schedule 40 drip piping	1 (25)	1 (25)	1 (25)	1 (25)
<b>** NOTE:</b> Field installed water seal outlets, tees, and connectors are shipped with case.				
<b>Refrigeration Outlet</b> <i>(TOP OF MERCHANDISER)</i>				
RH end of case to center of front refrigeration outlet	8 5/8 (219)	8 5/8 (219)	8 5/8 (219)	8 5/8 (219)
RH end of case to center of rear refrigeration outlet	50 3/4 (1289)	81 1/4 (2064)	111 5/8 (2835)	142 3/8 (3616)
Back O/S of case to center of front refrigeration outlet	42 3/4 (1086)	42 3/4 (1086)	42 3/4 (1086)	42 3/4 (1086)
Back O/S of case to center of rear refrigeration outlet	36 (914)	36 (914)	36 (914)	36 (914)
Outside bottom front supports from end of case	7 1/2 (191)	7 1/2 (191)	7 1/2 (191)	7 1/2 (191)
Center bottom front support from Centerline	24 (610)	24 (610)	24 (610)	24 (610)
<i>Distance between Center and Outside supports will vary.</i>				

# Tall Reach-in Island 2, 3, 4 and 5 Door Models



Husmann refrigerated merchandisers configured for sale for use in the United States meet or surpass the requirements of the DOE 2017 energy efficiency standards.

Standard Reach-in configuration consists of Innovator doors, energy efficient fan motors, and EcoShine II LED vertical lighting.

Refrigeration and electrical connections are on top. Overhead piping and electrical circuits are required.

Dimensions shown as in. & (mm).

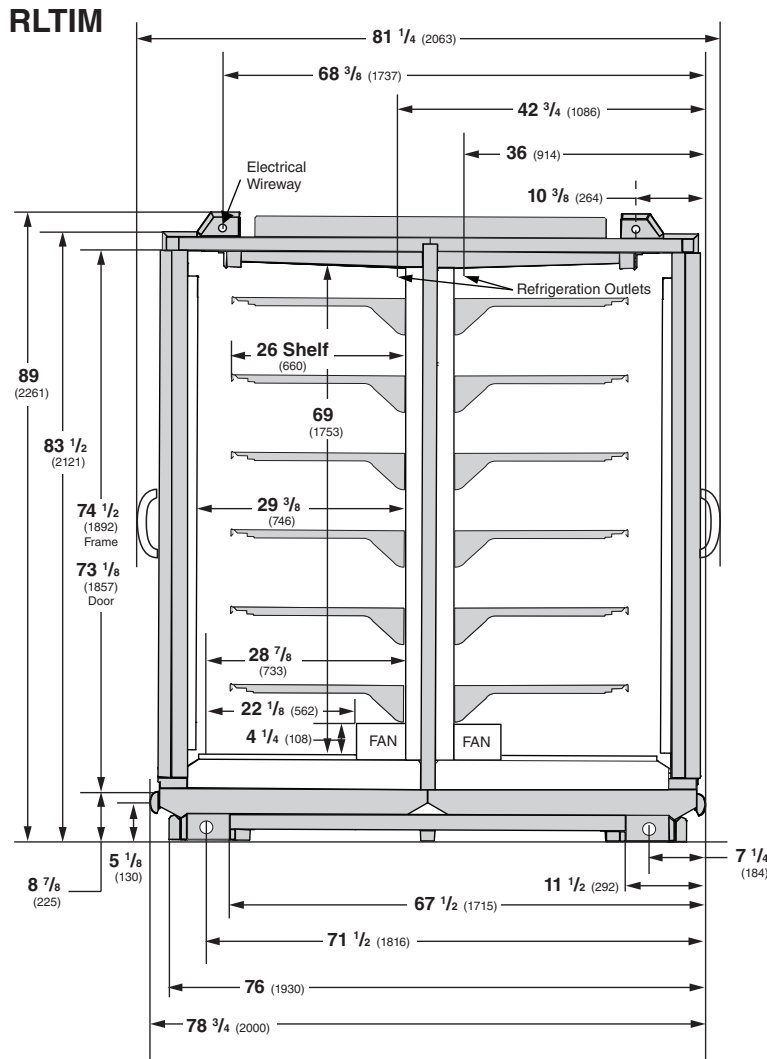

**Estimated Charge per Side \*\*\***

<b>2 Dr</b>	2.3 lb	37 oz	1.0 kg
<b>3 Dr</b>	3.2 lb	51 oz	1.4 kg
<b>4 Dr</b>	4.1 lb	66 oz	1.8 kg
<b>5 Dr</b>	5.1 lb	82 oz	2.3 kg

\*\*\*This is an average for all refrigerant types. Actual refrigerant charge may vary by approximately half a pound (8 oz / 0.2 kg).

**NSF Certification**

This merchandiser model is manufactured to meet NSF/ANSI (National Sanitation Foundation) Standard #7 requirements for construction, materials & cleanability.

**RLTIM**  
With *Innovator* Doors  
Low Temperature

*Refrigeration data is PER SIDE.*

**REFRIGERATION DATA§**

Note: This data is based on store temperature and humidity that does not exceed 75°F and 55% R.H.

	FF	IC	AHRI Rating*
Discharge Air (°F)	-5	-12	-2
Evaporator (°F)	-9	-17	-7
Unit Sizing (°F)	-12	-20	-10

\*With door A/S controller.

*Btulhr/door/side\**

INNOVATOR**			
Parallel	950	1035	870
Conventional	965	1055	900
INNOVATOR III			
Parallel	940	1025	870
Conventional	955	1045	900

§ Average evaporator temperature shown. Use dew point for high glide refrigerants for unit sizing. Care should be taken to use the dew point in PT tables for measuring and adjusting superheat. Adjust evaporator pressure as needed to maintain discharge air temperature shown.

**DEFROST DATA**

	FF	IC
Frequency (hr)	24	24
Defrost Water (lb/door/side/day)	1.2	1.2

(± 15% based on case configuration and product loading).

<i>ELECTRIC</i>		
Temp Term (°F)	FF	IC
Temp Term (°F)	48°	48°
Failsafe (minutes)	50	50

<i>GAS</i>		
Duration (minutes)	FF	IC
Duration (minutes)	22	22
OFFTIME	Not Recommended	

**CONVENTIONAL CONTROLS**

Low Pressure Backup Control		
	FF	IC
CI/CO (Temp °F)**	-18°/-34°	-26°/-45°

**Indoor Unit Only, Pressure Defrost Termination (Temp °F)\*\***  
Not Recommended

\*\*\*Use a Temperature Pressure Chart to determine PSIG conversions.

# RLTIM

With *Innovator* Doors  
Low Temperature

Hussmann recommends against frame heater cycling with *Innovator* doors to prevent door seals from freezing to the frames and tearing.

**Electrical data is per side — two circuits required per case.**

## Electrical Data

	2Dr	3Dr	4Dr	5Dr				
	2	3	4	5				
	Amperes				Watts			
	2Dr	3Dr	4Dr	5Dr	2Dr	3Dr	4Dr	5Dr
<b>Energy Efficient Evaporator Fan</b>								
120V 50/60Hz Innovator	0.6	0.9	1.2	1.5	36	54	72	90
220V 50/60Hz Export Innovator	0.3	.45	0.9	1.2	36	54	72	90
<b>Door Anti-sweat Heaters</b>								
120V 50/60Hz Innovator	1.4	2.0	2.7	3.4	162	244	325	406
220V 50/60Hz Export Innovator	0.7	1.1	1.5	1.8	153	230	306	382
120V 50/60Hz Innovator III	0.8	1.2	1.6	2.0	94	140	187	234
<b>Frame Anti-sweat Heaters (on fan circuit)</b>								
120V 50/60Hz Innovator	0.96	1.43	1.92	2.4	115	172	230	288
220V 50/60Hz Export Innovator	0.5	0.8	1.1	1.3	115	172	230	288
<b>Minimum Circuit Ampacity</b>								
120V 50/60Hz Innovator	3.7	5.85	8.28	10.46				
220V 50/60Hz Exp Innovator Electric Defrost	1.93	3.33	4.78	5.79				
120V 50/60Hz Innovator III Electric Defrost	2.95	4.85	6.9	8.71				
220V 50/60Hz Exp Innovator III Electric Defrost	1.05	1.95	2.90	3.54				
Maximum Over Current Protection 120V	20	20	20	20				
Maximum Over Current Protection 220V	15	15	15	15				
<b>Defrost</b>								
Drain Heaters (Koolgas or Electric)								
120V 50/60Hz Standard	0.63	1.25	2.0	2.57	75	150	240	300
220V 50/60Hz Export	0.34	0.76	1.22	1.53	75	150	240	300
Electric Defrost Heater								
208V 50/60Hz Standard	6.72	10.08	13.46	16.82	1400	2100	2800	3500
220V 50/60Hz Export	7.11	10.66	14.24	17.79	1564	2345	3133	3914

ONLY LIGHTING CONFIGURATIONS THAT ARE COMPLIANT WITH THE U.S. DEPT. OF ENERGY (DOE) 2017 REGULATION ARE AVAILABLE FOR SALE FOR USE IN THE U.S.A.

	2Dr	3Dr	4Dr	5Dr	2Dr	3Dr	4Dr	5Dr
<b>Standard Vertical LED Lighting</b>								
Hussmann EcoShine II™ - A (120V)	0.35	0.53	0.71	0.89	42.5	63.8	85.1	106.4
Hussmann EcoShine II™ - A (220V Export)	0.19	0.29	0.39	0.48	42.5	63.8	85.1	106.4
<b>Optional Vertical LED Lighting</b>								
Hussmann EcoShine II™ - B (120V)	0.36	0.52	0.68	0.84	43.2	62.3	81.4	100.5
Hussmann EcoShine II™ - B (220V Export)	0.20	0.28	0.37	0.46	43.2	62.3	81.4	100.5

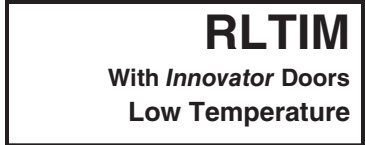

**Product data is PER SIDE.**

**Product Data**

<i>Recommended Usable Cube</i> <sup>1</sup> (Cu Ft/Dr)	34.44 ft <sup>3</sup> /Dr (0.98 m <sup>3</sup> /Dr)
<i>AHRI Total Display Area</i> <sup>2</sup> (Sq Ft/Dr)	14.26 ft <sup>2</sup> /Dr (1.32 m <sup>2</sup> /Dr)
<i>Shelf Area</i> <sup>3</sup> (Sq Ft/Dr)	32.27 ft <sup>2</sup> /Dr (3.00 m <sup>2</sup> /Dr)

- <sup>1</sup> AHRI Refrigerated Volume less shelving and other unusable space: Refrigerated Volume/Unit of Length, ft<sup>3</sup>/ft [m<sup>3</sup>/m]
- <sup>2</sup> Computed using AHRI 1200 standard methodology: Total Display Area, ft<sup>2</sup> [m<sup>2</sup>]/Unit of Length, ft [m]
- <sup>3</sup> Shelf surface area is composed of bottom deck plus standard shelf complement, as shown in the Hussmann *Product Reference Guide*. The standard shelf complement for this model is (6) rows of 22-inch shelves.

ESTIMATED SHIPPING WEIGHT <sup>4</sup>						
Case	<i>1 Dr</i>	<i>2 Dr</i>	<i>3 Dr</i>	<i>4 Dr</i>	<i>5 Dr</i>	Solid End (each)
<b>lb (kg)</b>	NA (NA)	1667 (756)	2322 (1053)	2945 (1336)	3611 (1637)	120 (55)

<sup>4</sup> Actual weights will vary according to optional kits included.



