

Q4-DV DELI/BAKERY SERVICE MERCHANDISER

U S E R M A N U A L

- Q4 - Q4-DV-4-R
- Q4-DV-8-R
- Q4-DV-12-R

Table of Contents

General Information	3	User Information	28
Case Sections	4	Start Up	28
Installation	5	Load Limits	28
Receiving Case	5	Basic Operation	28
Lifting and Transport	6	Maintenance	29
Drain Configuration	6	Case Cleaning	29
Skid Removal	7	Exterior Surfaces	29
Lifting Points	7	Interior Surfaces	29
Dollie Placement	7	Troubleshooting	31
Hardware Removal	7		
Level Case	8		
Leg Adjustment	8		
Joint Trim Packlist	9		
Setting and Joining	10		
Arm Adjustment	13		
Glass Adjustment	14		
Body Panels Install	15		
Refrigeration	16		
Refrigeration	16		
Refrigerant Piping	16		
Line Sizing	16		
Oil Traps	16		
Refrigerant Spec Sheet	17		
Electrical	18		
Merchandiser Electrical Data	18		
Electrical Connections	18		
Field Wiring	18		
Identification of Wiring	18		
Remove Rear Raceway	19		
Electrical Conduit (Electrical Box)	19		
Electrical Wiring Diagrams	20		

General Information

Case Description:

Description: Refrigerated Service Deli Merchandiser

Shipping Damage: All equipment should be thoroughly examined for shipping damage before and during unloading. This equipment has been carefully inspected at our factory and the carrier has assumed responsibility for safe arrival. If damaged, either apparent or concealed, claim must be made to the carrier Immediately.

Apparent Loss or Damage: If there is an obvious loss or damage, it must be noted on the freight bill or express receipt and signed by the carrier's agent; otherwise, carrier may refuse claim. The carrier will supply necessary claim forms.

Concealed Loss or Damage: When loss or damage is not apparent until after all equipment is uncrated, a claim for concealed damage is made. Make request in writing to carrier for inspection within 15 days, and retain all packaging. The carrier will supply inspection report and required claim forms.

Shortages: Check your shipment for any possible shortages of material (See Parts List page 9). If a shortage should exist and is found to be the responsibility of Hussmann Chino, notify Hussmann Chino. If such a shortage involves the carrier, notify the carrier immediately, and request an inspection. Hussmann Chino will acknowledge shortages within ten days from receipt of equipment.

Hussmann Chino Product Control: The serial number and shipping date of all equipment have been recorded in Hussmann's files for warranty and replacement part purposes. All correspondence pertaining to warranty or parts ordering must include the serial number of each piece of equipment involved, in order to provide the customer with the correct parts.

Location/Store Conditions: The Q4-DV refrigerated merchandiser has been designed for use only in air conditioned stores where temperature and humidity are maintained at or below 75°F Dry bulb and 55% relative humidity. DO NOT allow air conditioning, electric fans, ovens, open doors or windows (etc.) to create air currents around the merchandiser, as this will impair its correct operation.

Keep this booklet with the case at all times for future reference.

HUSSMANN®/CHINO

A publication of HUSSMANN® Chino
13770 Ramona Avenue • Chino, California 91710
(909) 628-8942 FAX
(909) 590-4910
(800) 592-2060



This equipment is to be installed to comply with the applicable NEC, Federal, State, and Local Plumbing and Construction Code having jurisdiction.

Case Sections

Q4-DV Multi-Deck Service Deli Case

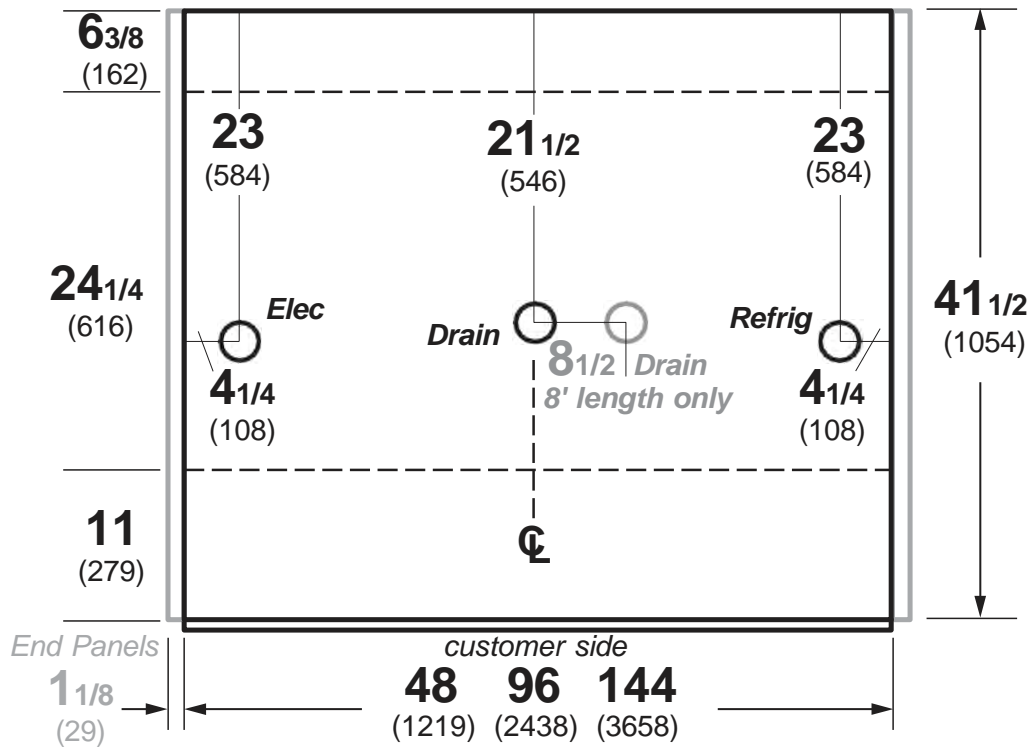
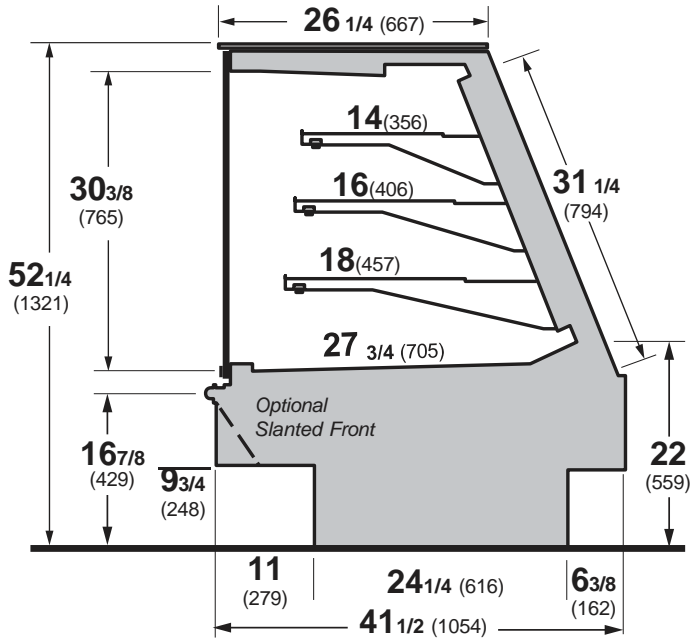

Unloading

NOTICE

Do NOT remove Foam Blocks from shelves and glass until the merchandisers are positioned for installation. Shelves or merchandising glass may be damaged.

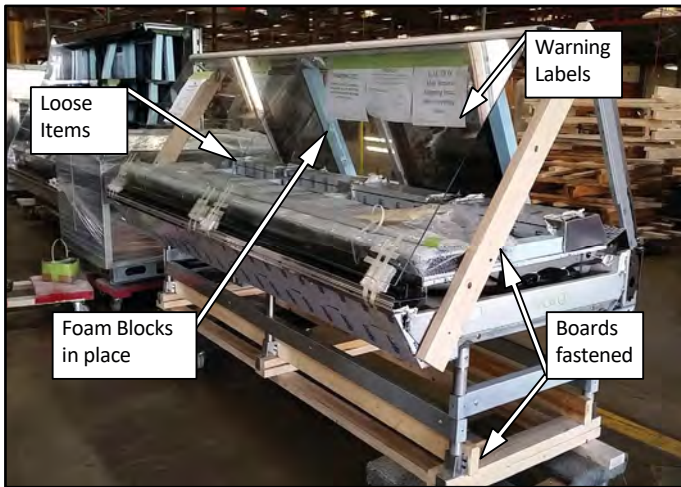

Case is to arrive at store as was shipped from factory. See reference above for proper shipment referencing. (Not actual case)

Receiving Case

Upon receiving your new Hussmann Case all equipment should be thoroughly examined for shipping damage before and during unloading. This equipment has been carefully inspected at our factory. Any claim for loss or damage must be made to the carrier. The carrier will provide any necessary inspection reports or claim form.

If there is obvious loss or damage, it must be noted on the freight bill or express receipt and signed by the carrier's agent; otherwise carrier may refuse claim.

Installation (cont'd)

Q4-DV Lifting and Transport Instructions

1. The Q4-DV can be lifted by a forklift at typical lifting points.
2. Ensure lower body panels are removed before lifting with a forklift. Serious damage will occur if the body panels are not removed. (Shipped loose from factory)
3. Make sure that fork spacing and width will not damage drain or come in contact with piping, or electrical lines
4. Be sure that the forks are long enough to support beyond the center of the case but not damage near components. Check for proper balance before moving. A minimum fork length of 36" is recommended for 68" wide cases

5. The Q4-DV merchandiser can be raised at one end underneath the deck with a forklift or J-Bar if forklift is not accesible to allow the placement of rollers or dollies.
6. Evenly support the entire base structure on rollers or dollies before attempting to move. Each Base Leg must have its own dollie to properly support the case.

WARNING

Improper placement of forks may damage drainage piping. Use a spotter when placing forks. Make sure that piping will not be damaged. Use J-Bars or Jacks if forks cannot be used safely

Lifting Points are typical and dependent upon size of case and refrigeration application, drainage configurations will call for altercations in Lifting Zones.

Below are the following drainage configurations and lifting should be altered to the expected model.

Q4-DV Drain Location

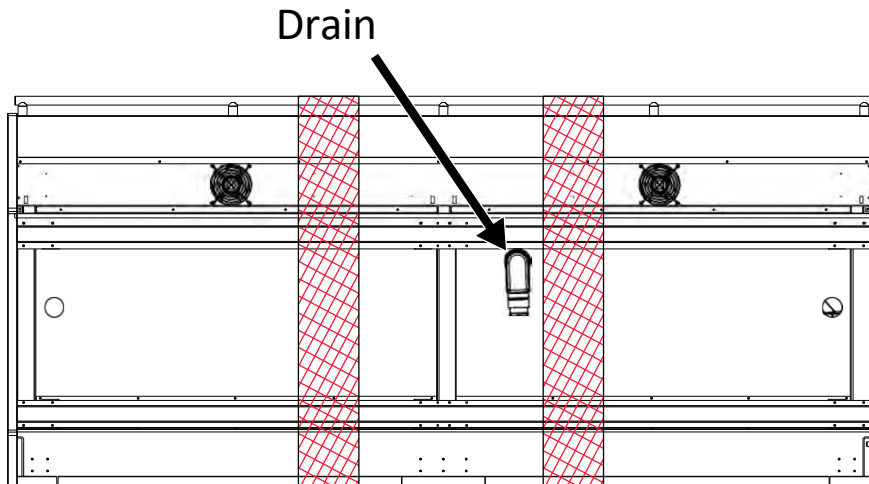

Installation (cont'd)

Skid Removal

Important: See lifting instructions to properly lift case when being placed on dollies or permanent location. (See page 6 for Lifting Instructions.)

Lifting Points

Leave all hardware and fittings in place until case is located at or near its preferred location. Using forklift or J-Bar lift the case from the skid and placing dollies underneath each base leg, proceed to moving the case to its designated location if not done so already.

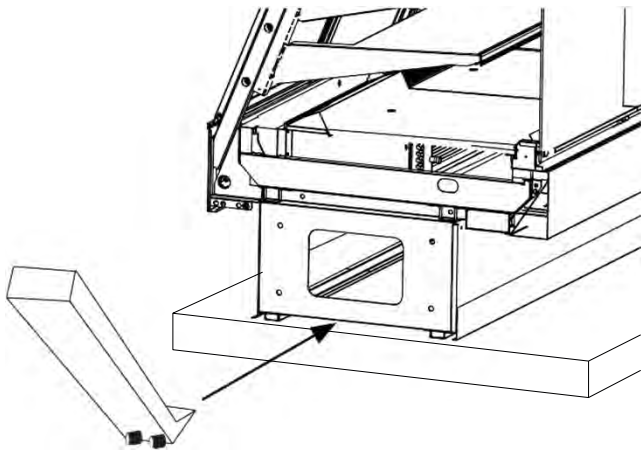

Dollie Placement

The Illustration below demonstrates perfect placement of a dollie per 1 side for both base legs of the merchandiser.

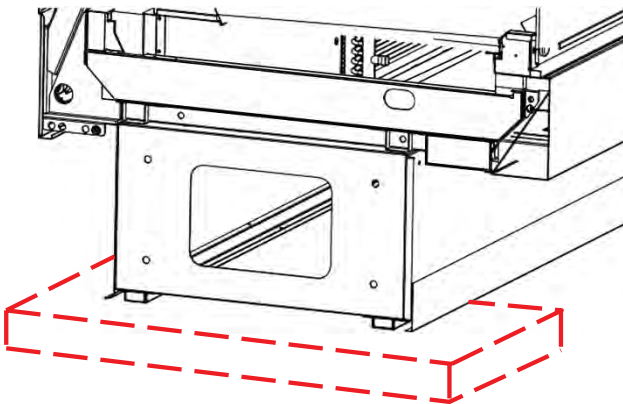

Move the fixture as close as possible to its perma-

nent location and then remove all packaging and prepare to remove off Skid. Remove all separately packed accessories such as kits, and panels. Check for damage before discarding packaging.

Hardware Removal

Remove screws as well as fastened plates bolted to skid at each base leg.

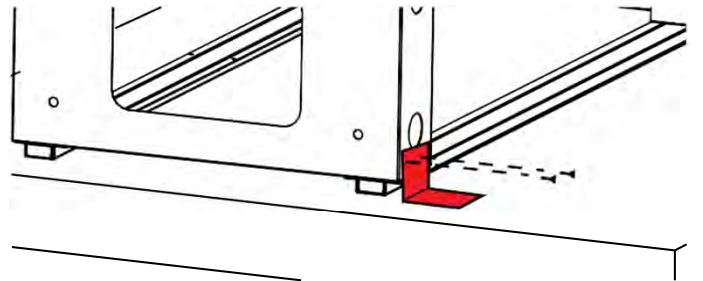

Remove fastened plates only upper base legs are to remain fastened onto case.

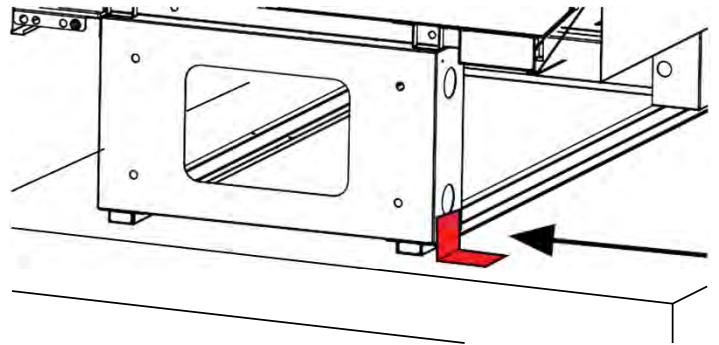

Once the fastened plates are removed a J-Bar can be used to lift at each end of the leg bases to remove the below skid

Installation (cont'd)

Level Case

Position the case at the highest point. Set a long magnetized level (4ft [1220 mm] or more) on either underneath the deck or on top of the case. Ensure to level case from front to back and side to side.

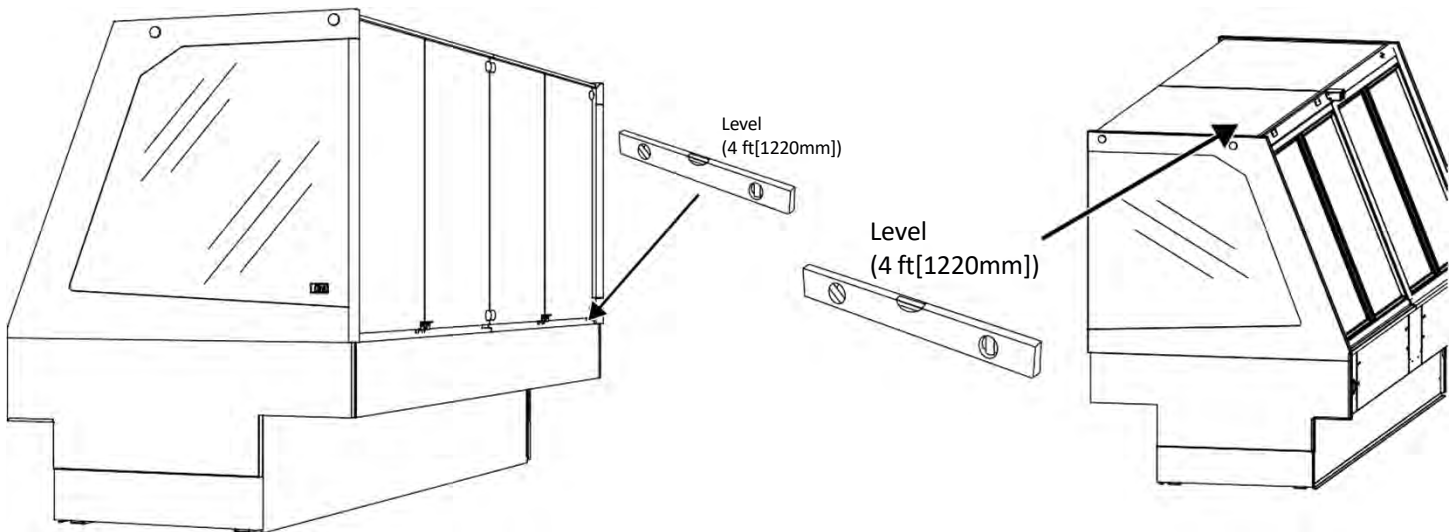

Level Adjustment

Use shims at each corner of the case to level out any discrepancies in order to optimize case performance and proper drainage.

Note: To avoid removing concrete flooring, begin line up levelling from the highest point of the store floor.

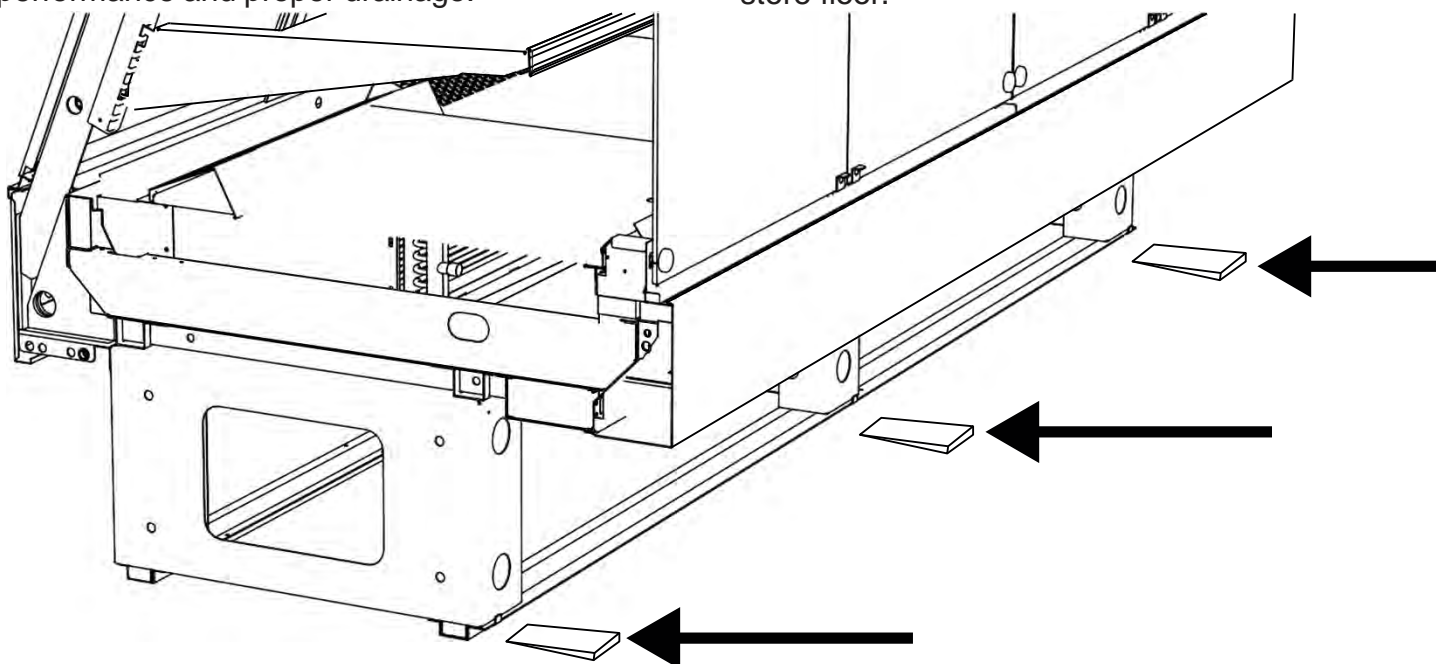

Joint Trim Packlist

INSPECTOR _____
 SALES ORDER # _____
 EXT COLOR _____
 INT FINISH __SS__/_BLACK__

Q4-DV PACKLIST CHECKSHEET

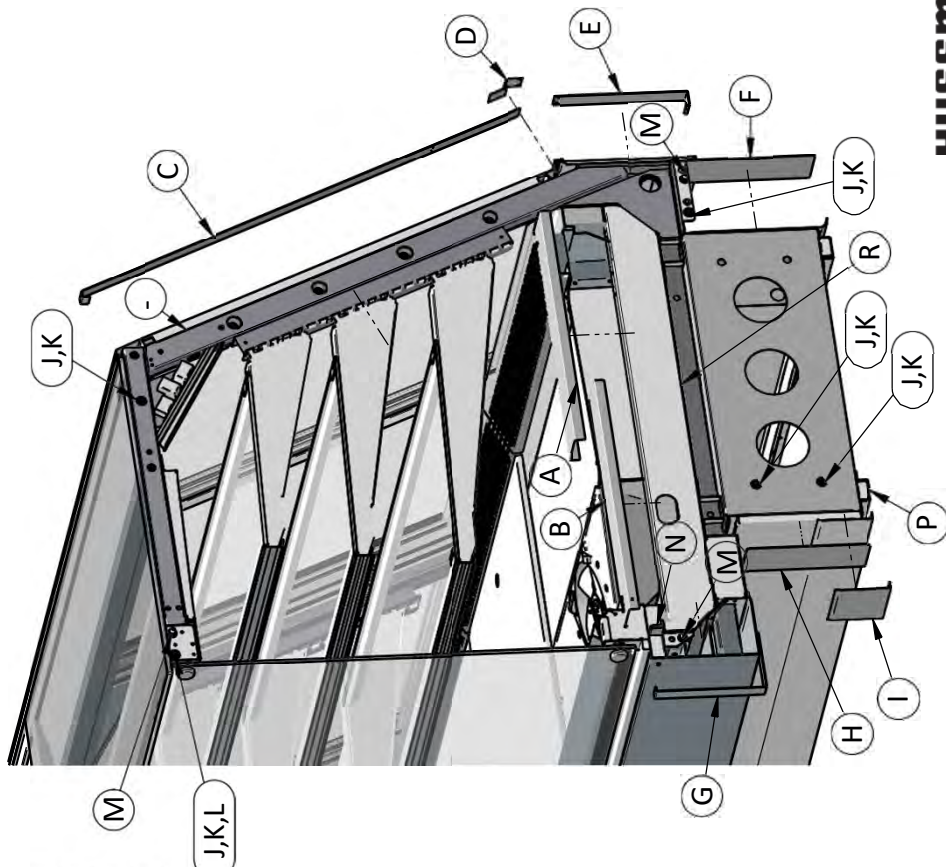

HUSSMANN
 REV A 08/19/2016

<input type="checkbox"/>	TRIM A	1H63905002	1	A
<input type="checkbox"/>	TRIM B	143394-2B	1	B
<input type="checkbox"/>	TRIM C	3012751004	1	C
<input type="checkbox"/>	TRIM D	3012752004	1	D
<input type="checkbox"/>	TRIM E	1H82376004	1	E
<input type="checkbox"/>	TRIM F	3012753004	1	F
<input type="checkbox"/>	TRIM G	3012750004 (STAINLESS) 3012750005 (EXT COLOR)	1	G
<input type="checkbox"/>	TRIM H	3012749004 (STAINLESS) 3012749005 (EXT COLOR)	1	H
<input type="checkbox"/>	TRIM I	2H00649004 (STAINLESS) 2H00649005 (BLACK)	1	I
<input type="checkbox"/>	WASHER, 5/16"	300-03-1315	5	J
<input type="checkbox"/>	BOLT, 3/8 - 16 X 1	300-03-0845	5	K
<input type="checkbox"/>	SPACER, NYLON, 5/800 X 1/4	2H04205800	1	L
<input type="checkbox"/>	ALIGNMENT PIN	0376408	3	M
<input type="checkbox"/>	ALIGNMENT TAB, PLEX	070778-PLX	1	N
<input type="checkbox"/>	SHIM	375-01-3004-B	20	P
<input type="checkbox"/>	GASKET SEAL TAPE	225-01-0628	10 FT	-
<input type="checkbox"/>	SEALANT, BUTYL, TUBE	100-01-0121	1	R
<input type="checkbox"/>	SEALANT, SILICONE, TUBE	100-01-0051 (CLEAR) 100-01-0063 (SILVER) 100-01-0065 (BLACK)	1	-
<input type="checkbox"/>	SCREW, SELF TAP #8 X 1/2	300-03-0037	10	-
<input type="checkbox"/>	VHB DOUBLE-SIDED TAPE	175-01-0562	10 FT	-
<input type="checkbox"/>	COUPLING, 2" PVC	225-01-0090	1	-
<input type="checkbox"/>	NIPPLE, 2" PVC	225-01-0577	1	-
<input type="checkbox"/>	ADAPTER, 1-1/2" PVC	225-01-1429	1	-
<input type="checkbox"/>	DRAIN TRAP, PVC	225-01-1552	1	-

Installation (cont'd)

Setting and Joining

The sectional construction of these models enable them to be joined in line to give the effect of one continuous display.

An alignment pin kit is supplied with every case and must be used in alignment.

Leveling

IMPORTANT! IT IS IMPERATIVE THAT CASES BE LEVELED FROM FRONT TO BACK AND SIDE TO SIDE PRIOR TO JOINING. A LEVEL CASE IS NECESSARY TO INSURE PROPER OPERATION, WATER DRAINAGE, GLASS ALIGNMENT AND OPERATION OF THE HINGES SUPPORTING THE GLASS. LEVELING THE CASE CORRECTLY WILL SOLVE MOST HINGE OPERATION PROBLEMS.

Snapping Chalk Lines

Prepare permanent positioning by marking floors with Chalk snap lines where cases are to be located. Chalk lines are to run along the base or legs of cases.

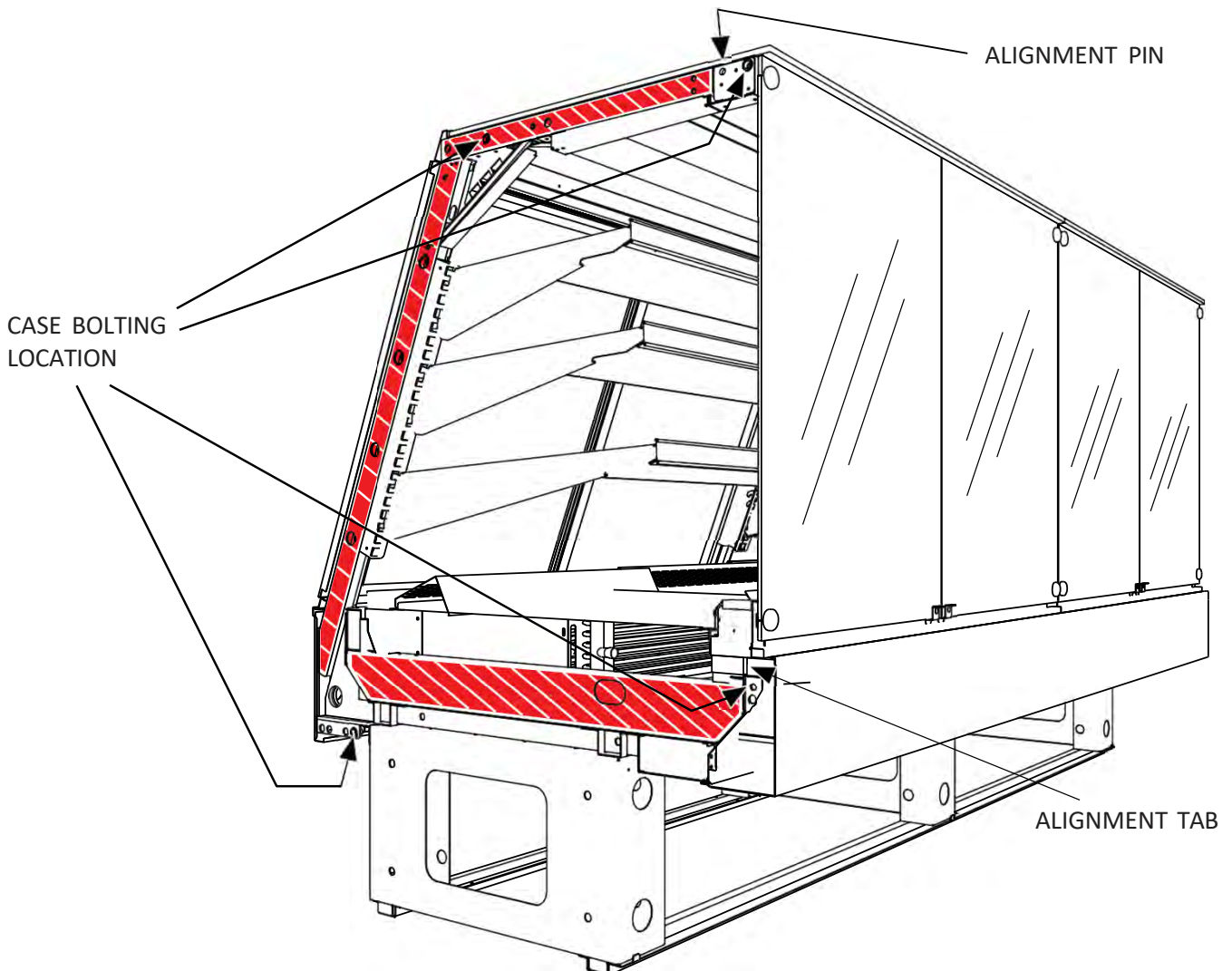
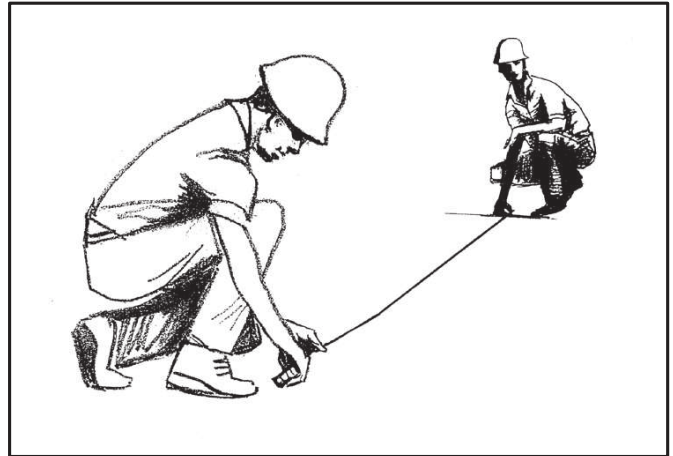

Installation (cont'd)

Setting

STEP 1. Using case blueprints, measure off and mark on the floor the exact dimensions of where the cases will sit. Snap chalk line for front and back positions of base rail or pedestal. Mark the location of each joint front and back. Find the highest point throughout the lineup. **FLOORS ARE NORMALLY NOT LEVEL!** Determine the highest point of the floor; cases will be set off this point. All cases in the entire lineup must be brought up to the highest level of the case sitting at the highest point in the lineup.

STEP 2. Set first case over the highest part of the floor and adjust legs so that case is level.

STEP 3. Set second case within one foot (1') of the first case. Keep the supports along the length of the case and far end of case. Level case to the first using the instructions in step one.



**ATTENTION
INSTALLER**

It is the contractor's responsibility to install case(s) according to local construction and health codes.



CAUTION

Do not use bolts to pull cases together.

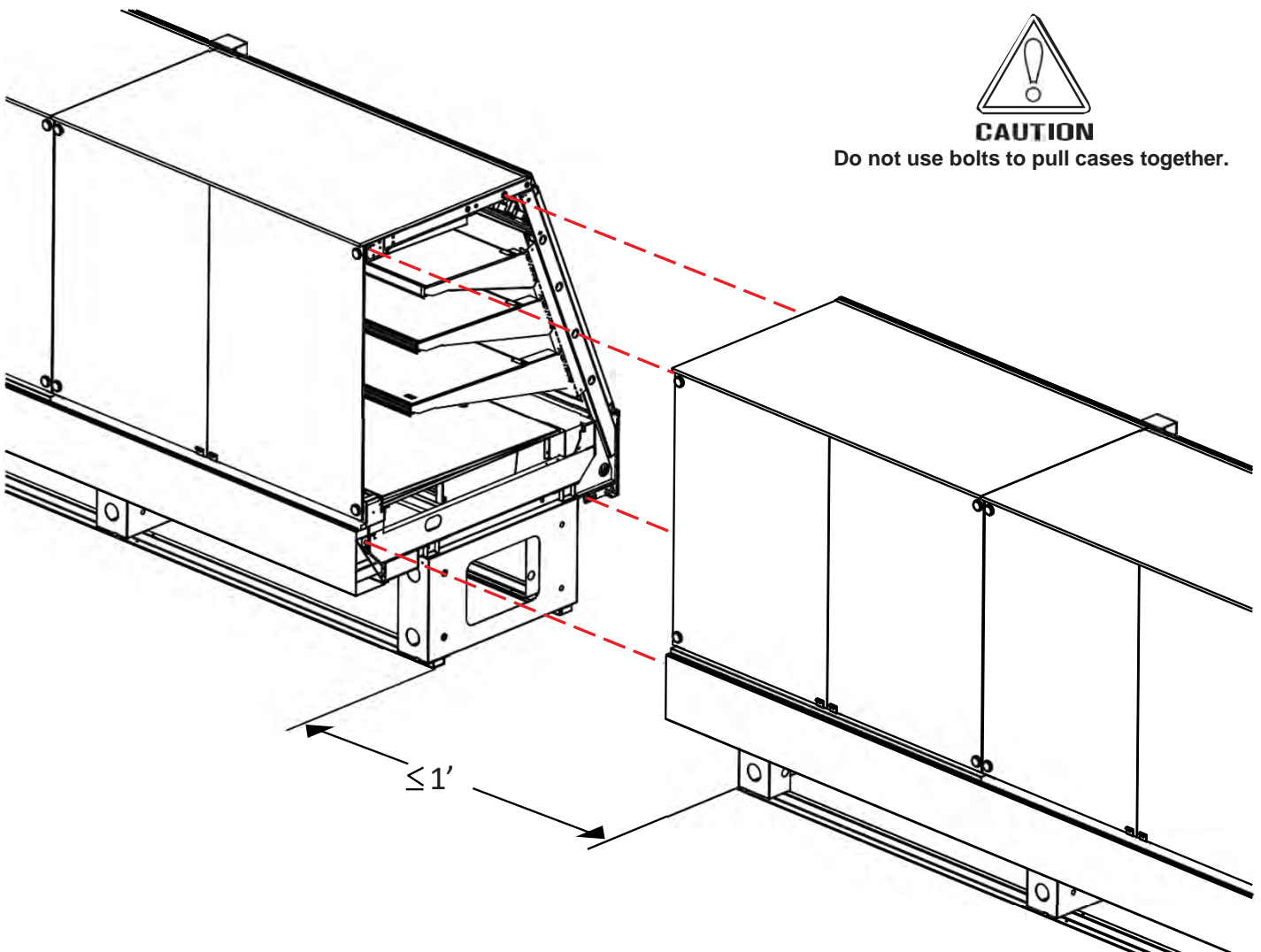

Installation (cont'd)

STEP 4. Apply liberal bead of case joint sealant (Silicone) to first case. Sealant area is shown in illustration. Apply heavy amount to cover entire shaded area. (pg10)

STEP 5. Slide second case up to first case snugly. Then level second case to the first case so glass front, bumper and top are flush.

STEP 6. To compress butyl at joint, use two Jurgenson wood clamps. Make sure case is level from front to back and side to side on inside bulkheads at joint.

STEP 7. Attach sections together.

STEP 8. Apply bead of butyl to top of bulk heads and slide on stainless steel bulkhead cap as pictured below. Also apply silicone to seam between joints.

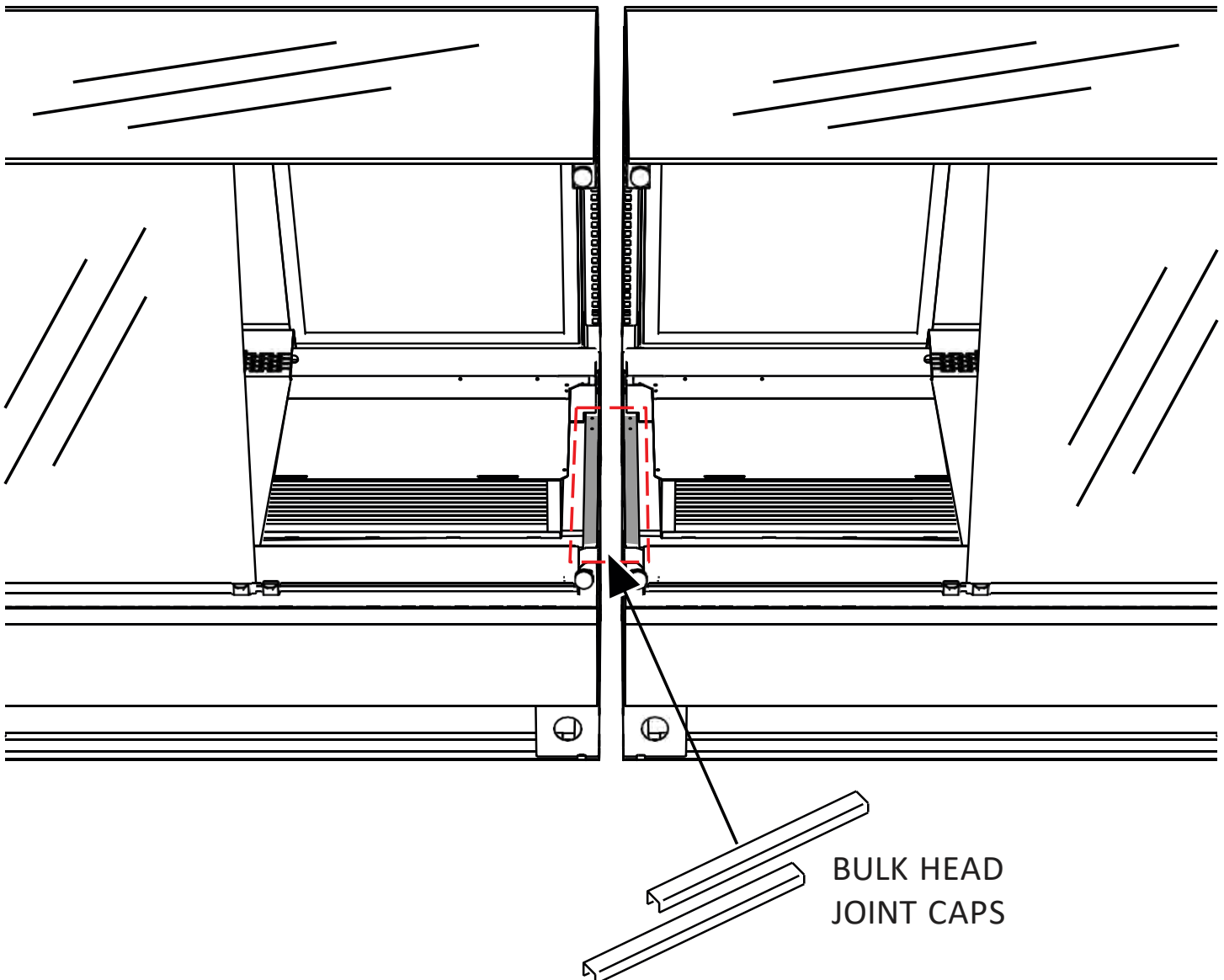

Installation (cont'd)

Q4-DV Arm Adjustment

Step 1. Ensure case is level. Check level at bulk-head as shown. (Level 1)

Step 2. Unscrew and remove access covers.

Step 3. Loosen top and bottom hinge vertical adjustment screws.

Step 4. Place level on the top of case as shown (Level 2)

Step 5. Using a 1/2" open-ended wrench, turn the Turn-Buckle Connecting Rod until level 2 indicates that the arm is level (Note: Some Turn-Buckles may be reverse threaded.) Test turning direction by observing the effect of turn direction.

IMPORTANT! Preload the canopy arm to minimize sag from product.

IMPORTANT! ATTEMPTING TO COMPENSATE FOR POOR INSTALLATION PRACTICES BY MANIPULATING THE CANOPY HARDWARE WILL RESULT IN UNSATISFACTORY WORKMANSHIP AND POSSIBLY CAUSE HARDWARE FAILURE AND/OR INJURY.

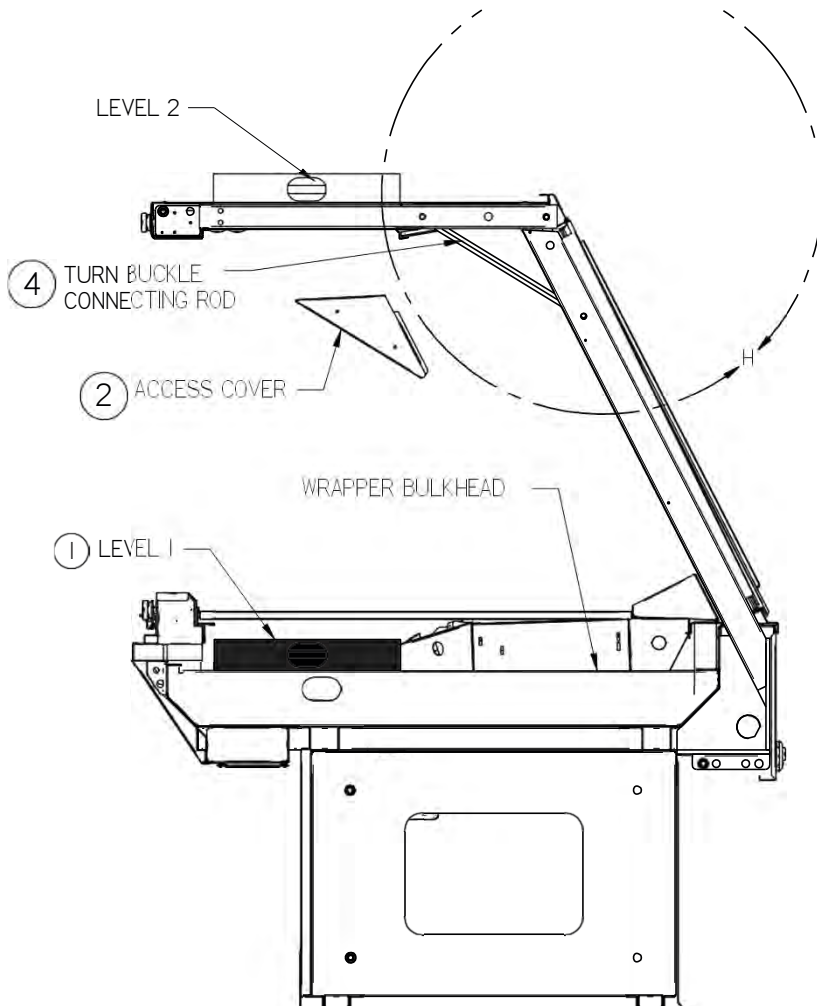
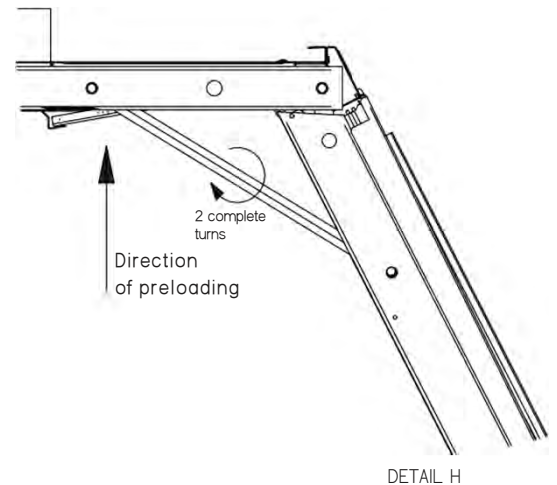

Installation (cont'd)

Q4-DV Glass Adjustment

Follow these steps accordingly to properly and safely adjust the position of the front glass.

BEFORE ADJUSTING GLASS

- SET, LEVEL, AND BOLT TOGETHER ALL CASES.
- DOUBLE CHECK LEVELING FOR ALL CASES.
- DO NOT MOVE LINEUP DURING ADJUSTMENT.

Glass must be parallel to ledge when viewed from front. Glass height should be centered on "V" glass seal as demonstrated below.

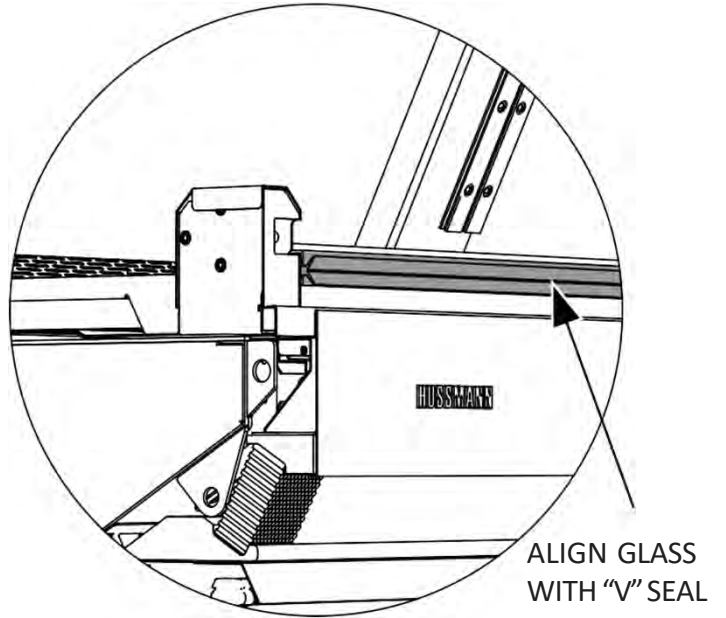

Before adjusting glass
Set, Level, and Bolt together all cases
Double check leveling for all cases
Do not move lineup during adjustment

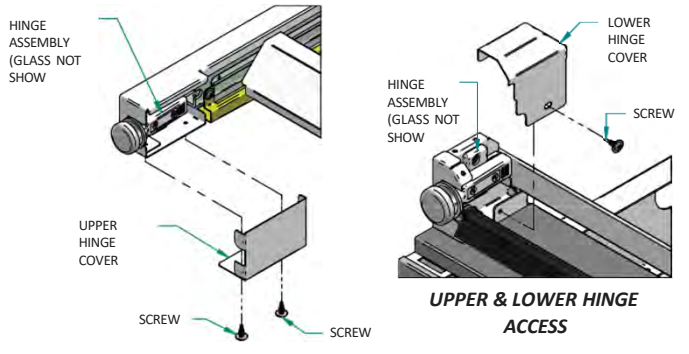

UP & DOWN

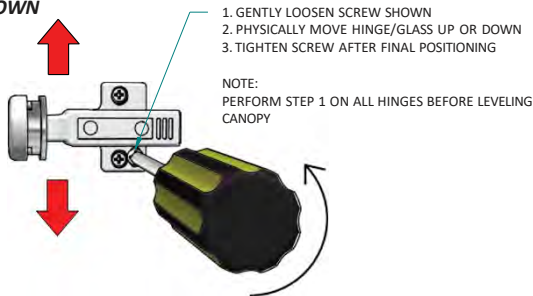

IN & OUT

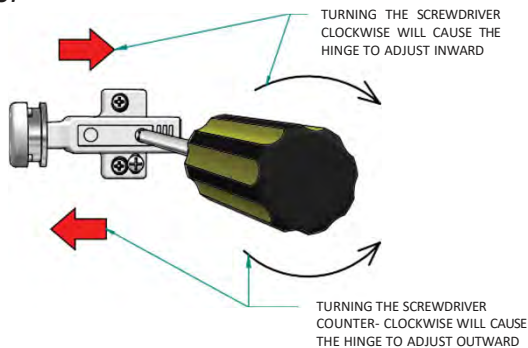

LEFT & RIGHT

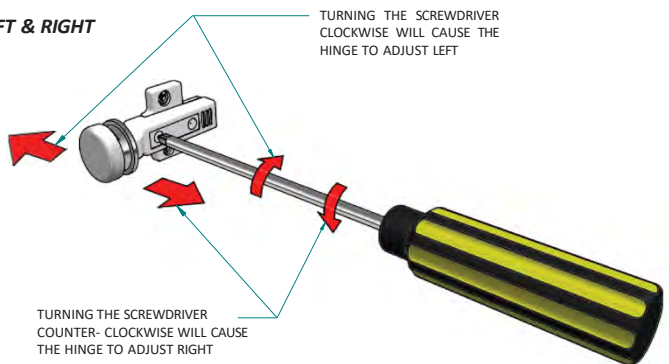

Installation (cont'd)

Front Body Panel Install

A Phillips Screw Driver/Bit will be needed to install body panels.

To begin Bottom panel assembly place panel A along side the base of the case and lower panel on to support hooks along the bottom of the base (See illustration below for details).

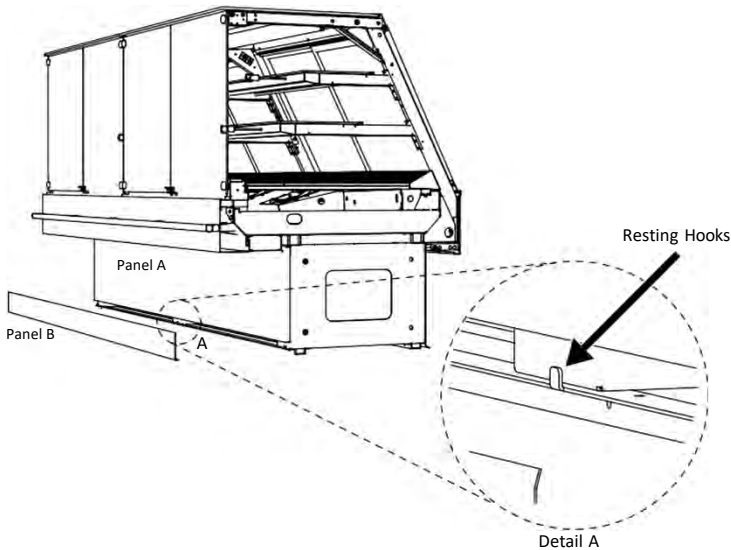

Fasten Rear Body Panel Install

- (1) Align pre drilled holes to base of case
- (2) Secure top and bottom of panel using fasteners as shown below.

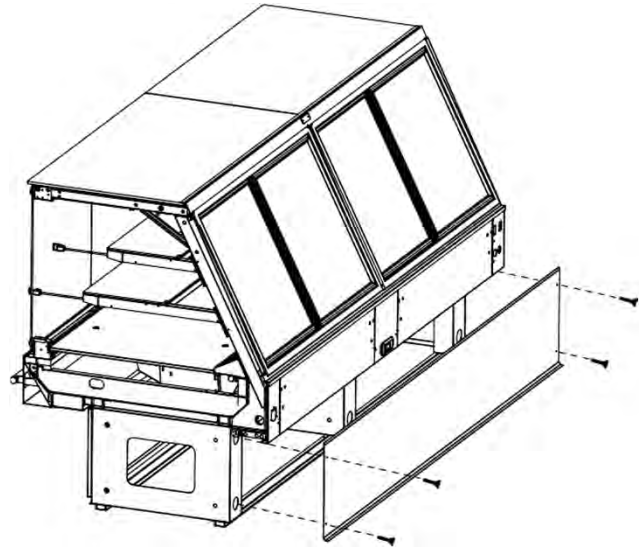

Fasten Front Body Panel Install

- (1) Secure Panel A with top fasteners only.
- (2) Overlay Panel B to bottom of Panel A as shown in illustration below

*Note Panel B will be attached freely with no pre drilled holes.

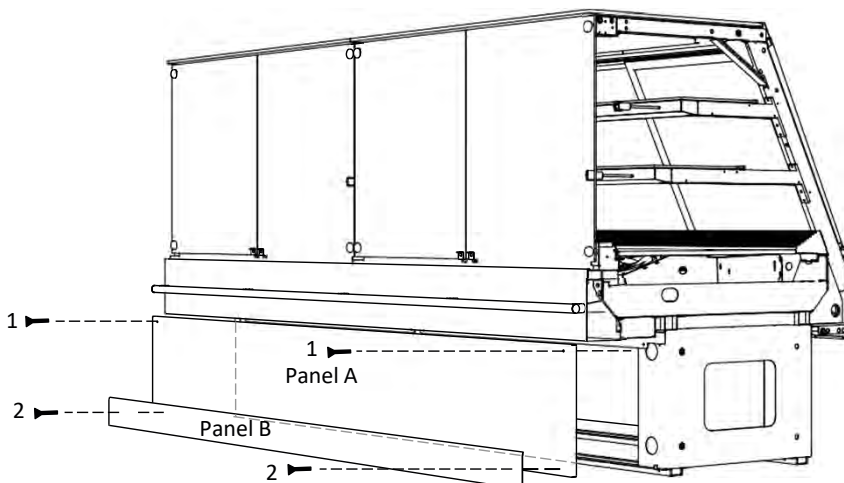

Refrigeration

Refrigerant

The correct type of refrigerant will be stamped on each merchandiser's serial plate. **The case refrigeration piping is pressurized with a nitrogen holding charge, leak tested and factory sealed.** Before making refrigeration hookups, depress universal line valve (Shraeder Valve) to ensure that coils have maintained pressure during shipment. If in the case pressure was not maintained, contact your Hussmann Service Tech for further assistance.

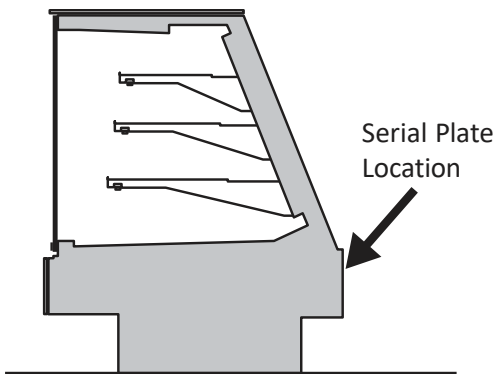

CAUTION

Refrigeration lines are under pressure. Refrigerant must be recovered before attempting to make any connections.

WARNING!

Do NOT apply thread sealer to ABS P-Trap.



Refrigerant piping

The refrigerant line connections are at the right hand end of the case (as viewed from the front) beneath the display pans. The merchandiser will beforehand ensure an earlier cut hole through the pod to exit the merchandiser for the refrigeration lines. After connections have been made, make certain to seal this outlet thoroughly if not sealed at factory already. Seal both the inside and outside. We recommend using an expanding polyurethane foam insulation.

Line Sizing

Refrigerant should be sized as shown on the refrigeration legend that is furnished for the store or according to the ASHRAE guidelines.

Oil Traps

Oil traps must be installed at the base of all suction line vertical risers on refrigerated cases.

P-Traps

P-traps must be installed at the base of all refrigerated cases. The 1 1/2" P-TRAP and threaded adapter must be installed to prevent air leakage and insect entrance into the fixture.



**ATTENTION
INSTALLER**

It is the contractor's responsibility to install case(s) according to local construction and health codes.

Refrigeration Spec Sheets



DELI / BAKERY SERVICE CASE
HUSSMANN - Q4-DV/BV (CHINO)

REVISION DATE 09/03/2025

DOE 2017 Energy Efficiency Compliant Hussmann refrigerated merchandisers configured for sale for use in the United States meet or surpass the requirements of the DOE 2017 energy efficiency standards.

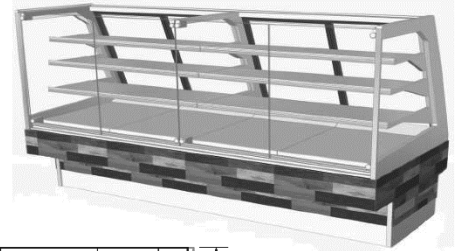

Q4-DV Multi-Deck Service Deli Case

Q4-BV Multi-Deck Service Bakery Case

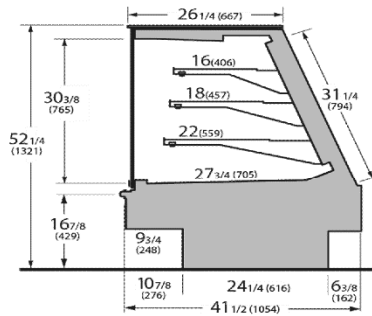
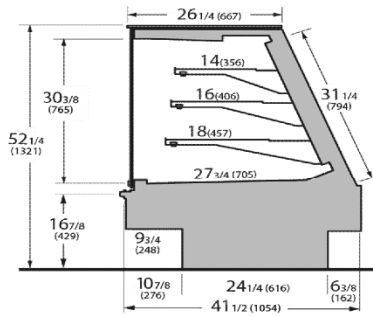

Q4-DV, BV

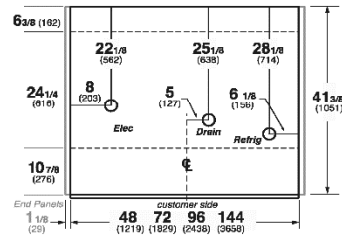

REFRIGERATION DATA:

CASE LENGTHS	CASE USAGE	CAPACITY ** (BTU/HR/FT)		TEMPERATURE (°F)			VELOCITY (FT/MIN)
		RATING CONDITION		EVAPORATOR		DISCHARGE AIR * (°F)	
		NSF 7	AHRI 1200	NSF 7	AHRI 1200	NSF 7	NSF 7
4', 5', 6', 8', 10', 12'	DELI / BAKERY	400	400	22	22	25~27	250~400
45° OS	DELI / BAKERY	1120	1120	22	22	26~28	250~400

CASE LENGTHS	EST. REFG. CHR.G. 404a (LBS)	20°F GLYCOL 6° RISE	
		GPM	PSI
4'	1.2	0.6	1.4
5'	1.3	0.8	2.3
6'	1.3	0.9	0.9
8'	1.4	1.2	1.7
10'	1.5	1.2	1.7
12'	1.6	1.7	2.0
45° OS	1.2	0.4	0.2

*FRONT DISCHARGE AIR MEASURED INSIDE AIR CURTAIN HONEYCOMB

**REFRIGERATION NOTES:

- 1) BTU'S INCLUDE TWO ROWS OF CANOPY LIGHTS. ADD 10 BTUS PER FOOT, PER SHELF FOR OPTIONAL LED LIGHTS
- 2) AHRI 1200 RATING POINT FOR ENERGY CONSUMPTION COMPARISON ONLY
- 3) RATING CONDITION IS NSF TYPE I, 75°F/55% RH

REFRIGERATION DATA CONTINUED:

ELEC. THERMOSTAT / AIR SENSOR SETTINGS			DEFROST TYPE	TIME (MIN)	DEFROST FREQUENCY (#/DAY)	TERM. TEMP (°F) COIL ONLY	DRIP TIME	DEFROST WATER (LBS/DAY/FT)
USAGE	CUT IN (°F)	CUT OUT (°F)						
SHELVES	27	24	OFF TIME	30	3	45	N/A	1.0
LOAF RACKS	26	25	OFF TIME	35	3	45	N/A	1.0

END PANEL WIDTH KEY		
# OF END PNLS	END PNL WIDTH (IN.)	TOTAL ADDED LENGTH (IN.)
1	1.125	1.125
2	1.125	2.25

ELECTRICAL DATA:

STANDARD FANS, HEATERS, LED LIGHTS (115 VOLT)

CASE LENGTH	EVAPORATOR FANS (SHELVES)					AIRSWEEP FANS			CANOPY LIGHTS LED		OPTIONAL LED SHELF LIGHTS		MAX. LED LOAD (W/ ALL OPTIONS)		ANTI-SWEAT HEATERS		CONVENIENCE OUTLETS (OPTIONAL)		
	# OF EVAP FANS	MOTOR RPM	DIAM (MM) / PITCH	AMPS	WATTS	# OF A/S FANS	AMPS	WATTS	AMPS	WATTS	AMPS	WATTS	AMPS	WATTS	AMPS	WATTS	# OUTLETS	VOLTS	AMPS
4'	2	1450	172 / 28°	0.16	24	1	0.04	5	0.30	35	0.27	31	0.57	66	1.30	150	1	115	15
5'	2	1450	172 / 28°	0.16	24	1	0.04	5	0.38	44	0.34	39	0.72	83	1.65	190	1	115	15
6'	4	1450	172 / 28°	0.32	48	2	0.08	9	0.42	49	0.26	30	0.69	79	1.96	225	1	115	15
8'	4	1450	172 / 28°	0.32	48	2	0.08	9	0.60	69	0.54	62	1.14	131	2.61	300	1	115	15
10'	4	1450	172 / 28°	0.32	48	2	0.08	9	0.77	88	0.68	78	1.45	166	3.26	375	1	115	15
12'	6	1450	172 / 28°	0.48	72	3	0.12	14	0.90	104	0.81	93	1.71	197	3.91	450	2	115	30
45° OS	1	2100	172 / 28°	0.16	12	1	0.04	5	0.12	14	0.13	15	0.25	29	1.04	120	1	115	15

CASE LENGTH	EVAPORATOR FANS (LOAF RACKS)				
	# OF EVAP FANS	MOTOR RPM	DIAM (MM) / PITCH	AMPS	WATTS
4'	2	1800	172 / 28°	0.28	24
5'	2	1800	172 / 28°	0.28	24
6'	4	1800	172 / 28°	0.56	48
8'	4	1800	172 / 28°	0.56	48
10'	4	1800	172 / 28°	0.56	48
12'	6	1800	172 / 28°	0.84	72

OPTIONAL HIGH OUTPUT LED LIGHTS (115 VOLT)

CASE LENGTH	CANOPY LIGHTS H.O. LED		OPTIONAL SHELF		MAX. H.O. LED LOAD		LEDGE LIGHTS (OPTIONAL)	
	AMPS	WATTS	AMPS	WATTS	AMPS	WATTS	AMPS	WATTS
4'	0.39	45	0.40	46	0.79	91	0.09	10
5'	N/A	N/A	N/A	N/A	N/A	N/A	0.11	13
6'	N/A	N/A	N/A	N/A	N/A	N/A	0.13	15
8'	0.78	90	0.79	91	1.57	181	0.18	21
10'	N/A	N/A	N/A	N/A	N/A	N/A	0.23	26
12'	1.17	135	1.19	137	2.36	272	0.27	31
45° OS	N/A	N/A	N/A	N/A	N/A	N/A	0.07	8

* Cases that use a mix of Loaf Racks and Shelves should use the Loaf Rack Fan Spec

Electrical

Merchandiser Electrical Data

Technical data sheets are shipped with this manual. The data sheets provide merchandiser electrical data. Refer to the technical data sheets and merchandiser serial plate for electrical information.

Electrical Connections

All wiring must be in compliance with NEC and local codes. All electrical connections including both supply circuits are to be made in the electrical J-Box.

ALWAYS CHECK THE SERIAL PLATE FOR COMPONENT AMPERES

Field Wiring

Field wiring must be sized for component amperes stamped on the serial plate (refer to pg 16 for location). Actual ampere draw may be less than specified.

Identification of Wiring

Leads for all electrical circuits are identified by colored plastic bands. These bands correspond to the color code sticker (shown below) located inside the merchandiser's wireway cover.



WARNING

--LOCK OUT/ TAG OUT--

To avoid serious injury or death from electrical shock, always disconnect the electrical power at the main disconnect when servicing or replacing any electrical component. This includes, but is not limited to, such items as doors, lights, fans, heaters, and thermostats.

STANDARD CASE WIRE COLOR CODE CODIGO DE COLORES DE LOS ALAMBRES PARA LAS VITRINAS ESTANDAR CODE COULER POUR FILS DE BOITIER NORMALISE		
<u>COLOR DESCRIPTION</u>	<u>DESCRIPCION</u>	<u>DESCRIPTION</u>
■ GROUND	TIERRA MASA	MASSE
■ ANTI-SWEAT	ANTICONDENSACION	ANTI-SUINTEMENT
■ LIGHTS	LUCES	ECLAIRAGE
■ RECEPTACLES	ENCHUFES	PRISE DE COURANT
■ T-STAT/SOLENOID 230VAC	TERMOSTATO/SOLENOIDE (230VAC)	SOUPAPE A SOLENOID (230 VAC)
■ T-STAT/SOLENOID 115VAC	TERMOSTATO/SOLENOIDE (115VAC)	SOUPAPE A SOLENOID (115 VAC)
■ T-STAT/SOLENOID 24VAC	TERMOSTATO/SOLENOIDE (24VAC)	SOUPAPE A SOLENOID (24 VAC)
■ FAN MOTORS	VENTILADORES	VENTILATEUR
BLUE CONDENSING UNIT	UNIDAD DE CONDENSACION	UNITE DE CONDENSATION

USE COPPER CONDUCTORS ONLY
UTILISEZ LES CONDUCTEURS DE CUIVRE SEULEMENT
UTILICE LOS CONDUCTORES DE COBRE SOLAMENTE
430-01-0338 R101003

Electrical Cont'd

Remove Rear Raceway

The merchandisers electrical access is located at the rear of the case. Fasteners must be removed in order to gain access. See illustration below.

Remove rear raceway from rear of case.

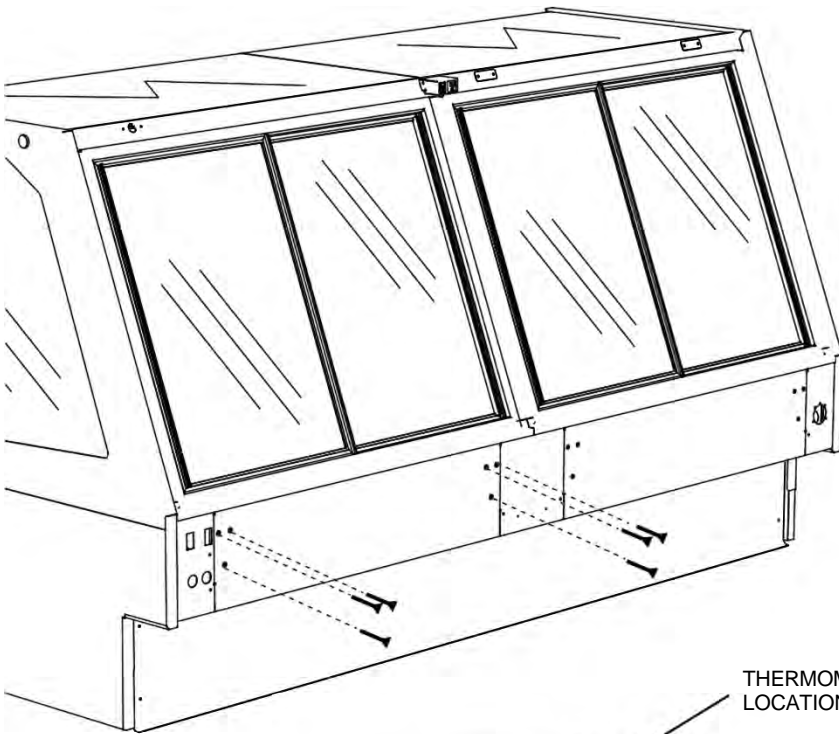

Electrical Conduit (Electrical Box)

The merchandisers electrical conduit can be found inside the compartment at the rear. Removing the raceway will gain access to the electrical components inside the J-Box allowing any maintenance necessary.

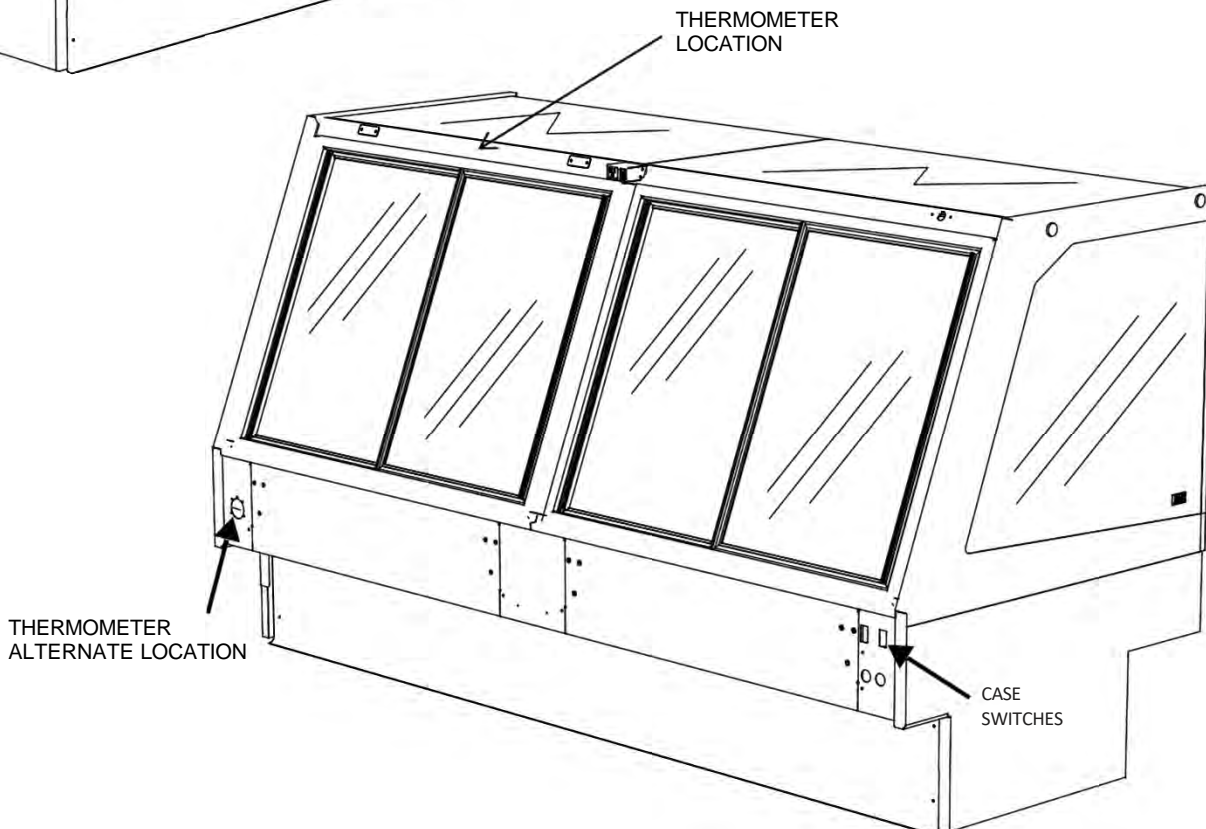

CIRCUIT #1	LOADING
120V	
115	

LIGHT CIRCUIT
.38A 40.5W @ 120V

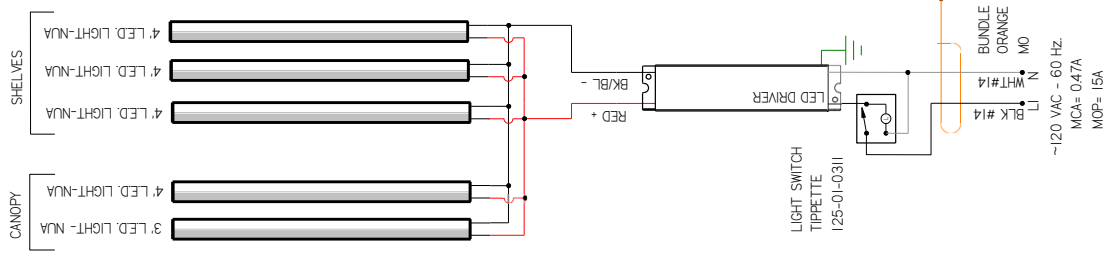

~120 VAC - 60 HZ
MCA= 0.47A
MOP= 15A

RL-45 NETWORK JACK
125-01-0202

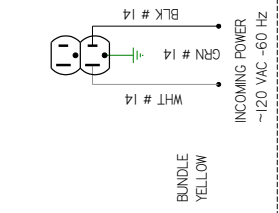

ALL SINGLE RECEPTACLES TO BE TIED TO DUPLEX GFCI RECEPTACLE

AIR SWEEP FAN
III 3166030
4.9W .08A @120VAC

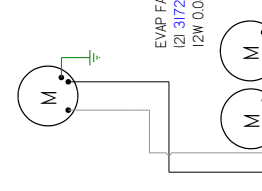

~120 VAC - 60 HZ
MCA= 0.49A
MOP= 15A

EVAP FAN MOTOR
I21 3172574
12W 0.08A @120VAC

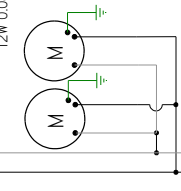

~120 VAC - 60 HZ
MCA= 1.63A
MOP= 15A

AIR SWEEP HEATER
125-01-1304

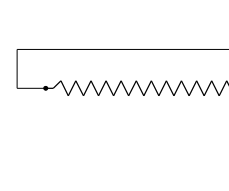

~120 VAC - 60 HZ

CIRCUIT #2

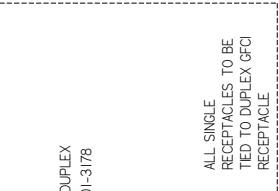

SOLENOID VALVE
1.4A @ 120VAC

DIGITAL T-STAT

SENSOR

WHITE #14

BLACK #14

WHITE #14

N LI

~120 VAC - 60 HZ

BUNDLE WHITE/BLACK

REV	ECN	DATE	REVISION DESCRIPTION	REV BY	CHK BY	APPR BY
A	ECN-CAP-0003237	2016/06/29	RELEASED TO PRODUCTION	CB	CB	CB
B	ECN-CAP-0005113	2017/02/03	CHANGED T-STAT TO DIGITAL	CB	CB	CB
C	ECN-C00-0018444	2020/01/06	RE-LABELLED DIGITAL T-STAT	CB	CB	CB
D	ECN-C00-0018270	2022/01/27	NEW LIGHTS	CB	CB	CB
E	ECN-C00-0018837	2022/01/17	CHANGED A.S. FAN MOTOR	CB	CB	CB
F	ECN-C00-0018448	2023/09/29	CHANGED EVAP FANS & LIGHTS	CB	CB	CB
G	ECN-C00-0018716	2023/09/29	NEW FAN MOTORS	CB	CB	CB

HUSSMANN
DIAGRAM-Q4-DV-4R

MATERIAL - N/A
DATE DRAWN - 8-29-16
DRAWN BY - CRAIG BOOREY
REVIEWED BY - CRAIG BOOREY
APPROVED BY - CRAIG BOOREY
UNLESS OTHERWISE SPECIFIED DIMENSIONS ARE IN INCHES
TOLERANCES ARE:
DIMENSIONS .XX +.03 .XXX
ANGLES ± 2°
PROJECTION
E
3014115 | G



CIRCUIT #1
LOADING

120V	
2.7	

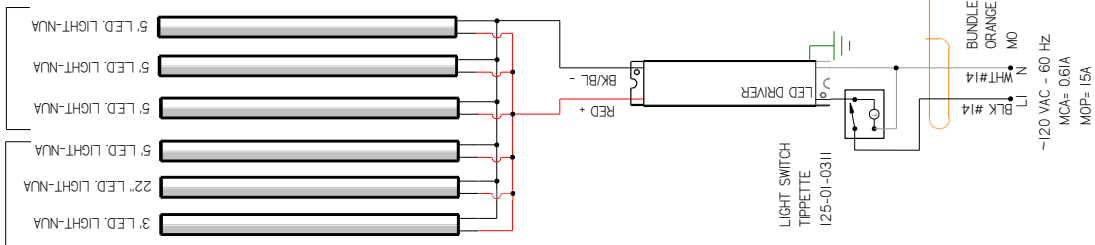

LIGHT CIRCUIT
.49A 53.2W @ 120V

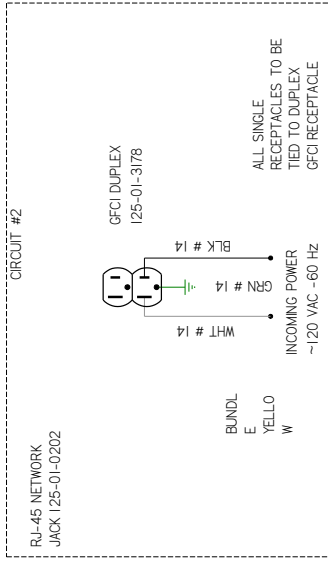

CIRCUIT #2

REV	EN	DATE	REVISION DESCRIPTION	REV BY	CHKD BY	APPR BY
A	ECN-CAP-0008197	2017/06/09	RELEASED TO PRODUCTION	CB	CB	CB
B	ECN-COD-001844	2022/01/06	RE-LABELLED DIGITAL T-STAT	CB	CB	CB
C	ECN-COD-0015270	2022/01/27	NEAL LIGHTS	CB	CB	CB
D	ECN-COD-0016537	2022/01/17	CHANGED AS FAN MOTOR	CB	CB	CB
E	ECN-COD-0018448	2022/01/02	CHANGED EVAP PANS & LIGHTS	CB	CB	CB
F	ECN-COD-0018716	2022/01/02	NEW FAN MOTORS	CB	CB	CB

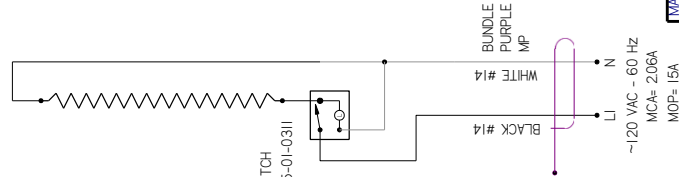
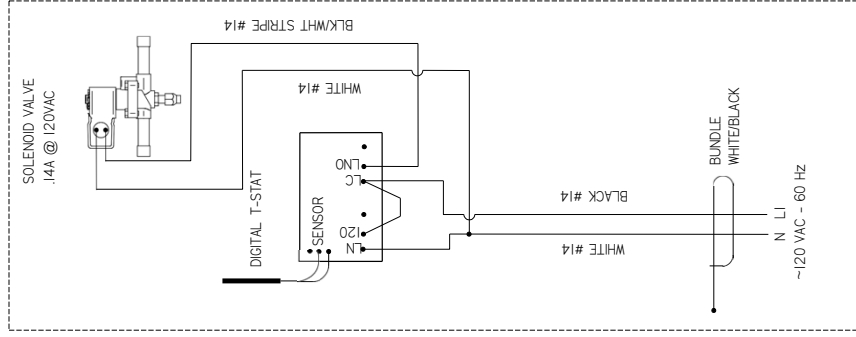

AIR SWEEP HEATER
190W 1.65A @ 120 VAC
125-01-1305

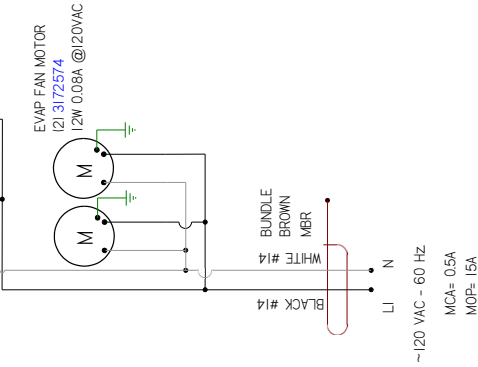

AIR SWEEP FAN
1213166030
49W 0.8A @120VAC

HUSSMANN
DIAGRAM-Q4-BV-5R

MATERIAL - N/A
DATE DRAWN - 6-9-17
DRAWN BY - CRAIG BOOREY
REVIEWED BY - CRAIG BOOREY
APPROVED BY - CRAIG BOOREY
SHEET 1 OF 1
UNLESS OTHERWISE SPECIFIED DIMENSIONS ARE IN INCHES
TOLERANCES ARE:
HOLE DIMENSIONS: .0005, .0010, .0015, .0020, .0025, .0030, .0035, .0040, .0045, .0050, .0055, .0060, .0065, .0070, .0075, .0080, .0085, .0090, .0095, .0100
DECIMALS .XX +.03, .XXX
ANGLES ± 2°

PROJECTION
E
F



NOTES:
CASE MUST BE GROUNDED
WHEN PASSING WIRES THROUGH METAL HOLES A GROMMET MUST BE USED

CIRCUIT #1	LOADING
	120W
	20

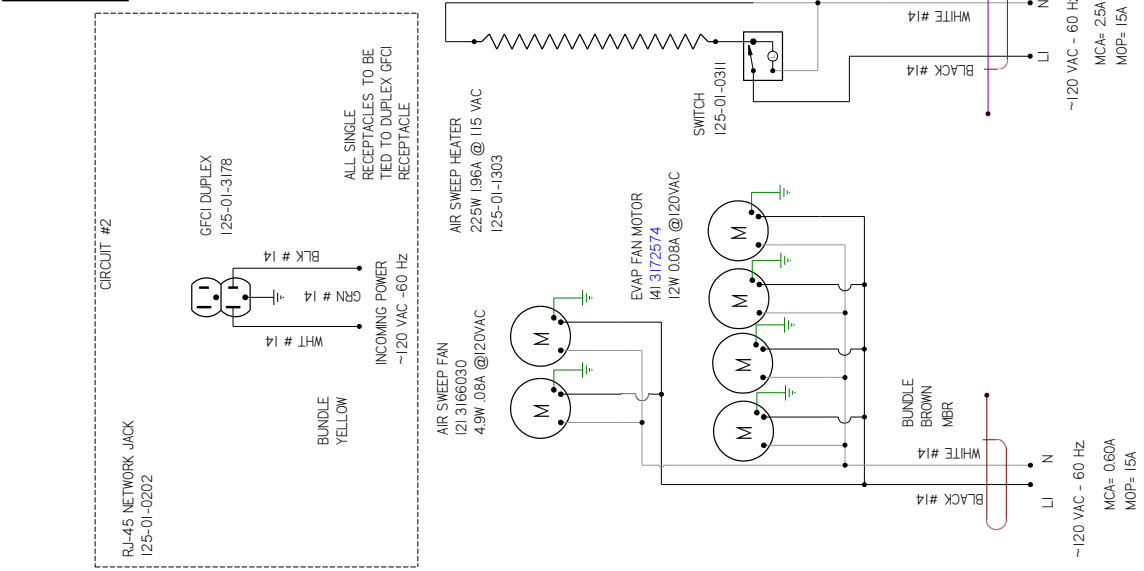
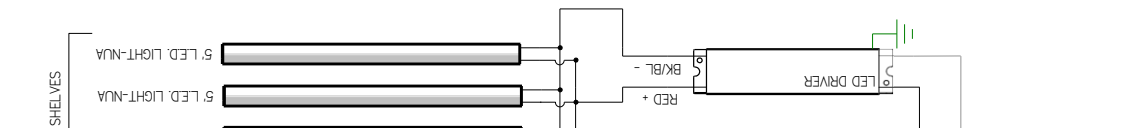
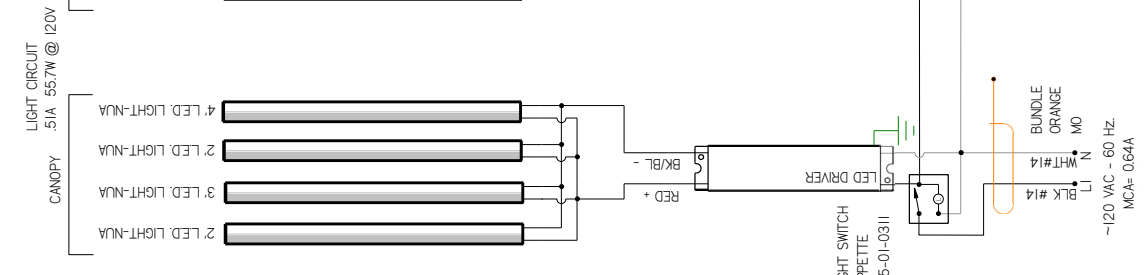
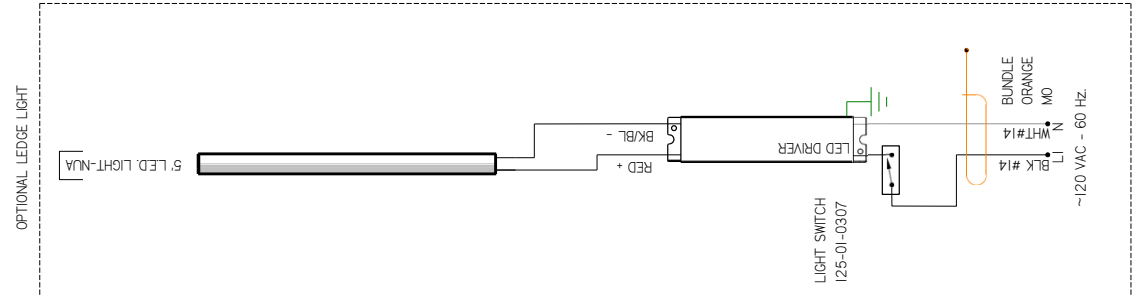

REV	EN	DATE	REVISION DESCRIPTION	REV BY	CHK BY	APPR BY
A	ECN-CAP-0006459	2010/02/28	RELEASED TO PRODUCTION	CB	CB	CB
B	ECN-COD-001844	2020/01/08	RE-LABELLED DIGITAL T-STAT	CB	CB	CB
C	ECN-COD-0015270	2022/01/27	NEW LIGHTS	CB	CB	CB
D	ECN-COD-0016837	2022/01/07	CHANGED AS FAN MOTOR	CB	CB	CB
E	ECN-COD-0018448	2023/01/02	CHANGED EVAP FANS & LIGHTS	CB	CB	CB
F	ECN-COD-0018716	2023/01/02	NEW FAN MOTORS	CB	CB	CB

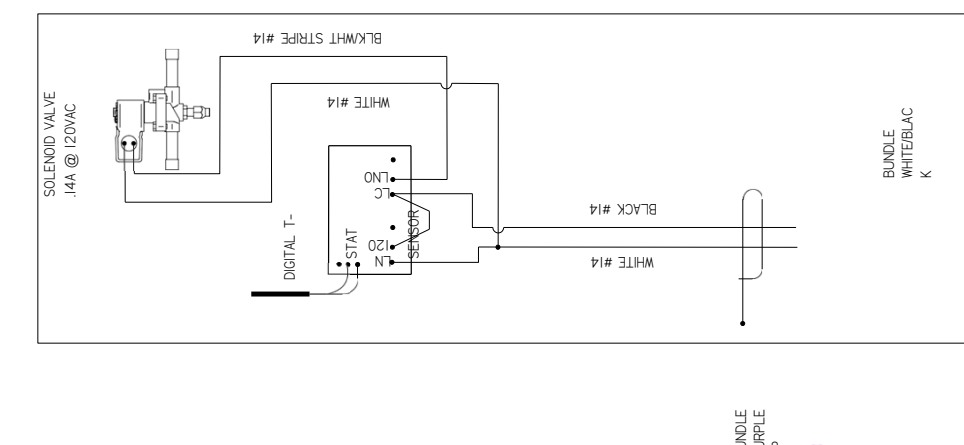

HUSSMANN
DIAGRAM-Q4-DV-6R

MATERIAL - N/A
DATE DRAWN - 2-28-17
DRAWN BY - CRAIG BOOREY
REVIEWED BY - CRAIG BOOREY
APPROVED BY - CRAIG BOOREY
SHEET NO. 1
UNLESS OTHERWISE SPECIFIED DIMENSIONS ARE IN INCHES
TOLERANCES ARE:
FRACTIONS .XX ±0.03 .XXX
DECIMALS .XX ±0.03 .XXX
±0.0

~120 VAC - 60 Hz
MCA= 2.5A
MOP= 15A

~120 VAC - 60 Hz
MCA= 0.60A
MOP= 15A

~120 VAC - 60 Hz
MCA= 0.64A
MOP= 15A

~120 VAC - 60 Hz
MCA= 2.5A
MOP= 15A

~120 VAC - 60 Hz
MCA= 0.60A
MOP= 15A

~120 VAC - 60 Hz
MCA= 2.5A
MOP= 15A

PROJECTION

3027072 | F

NOTES:
CASE MUST BE GROUNDED
WHEN PASSING WIRES THROUGH METAL HOLES A GROMMET MUST BE USED

CIRCUIT #1	LOADING
120V	
40	

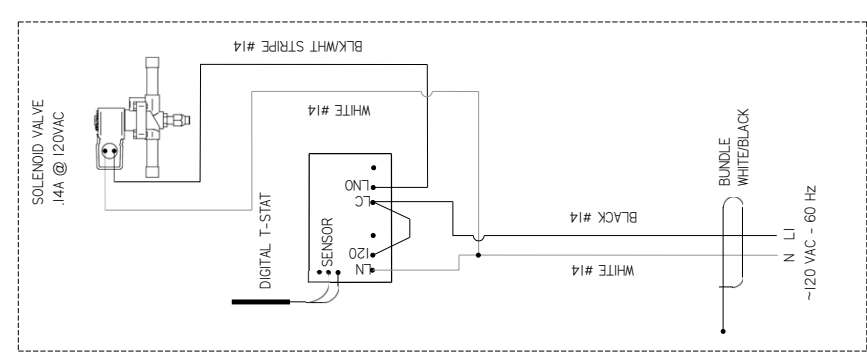
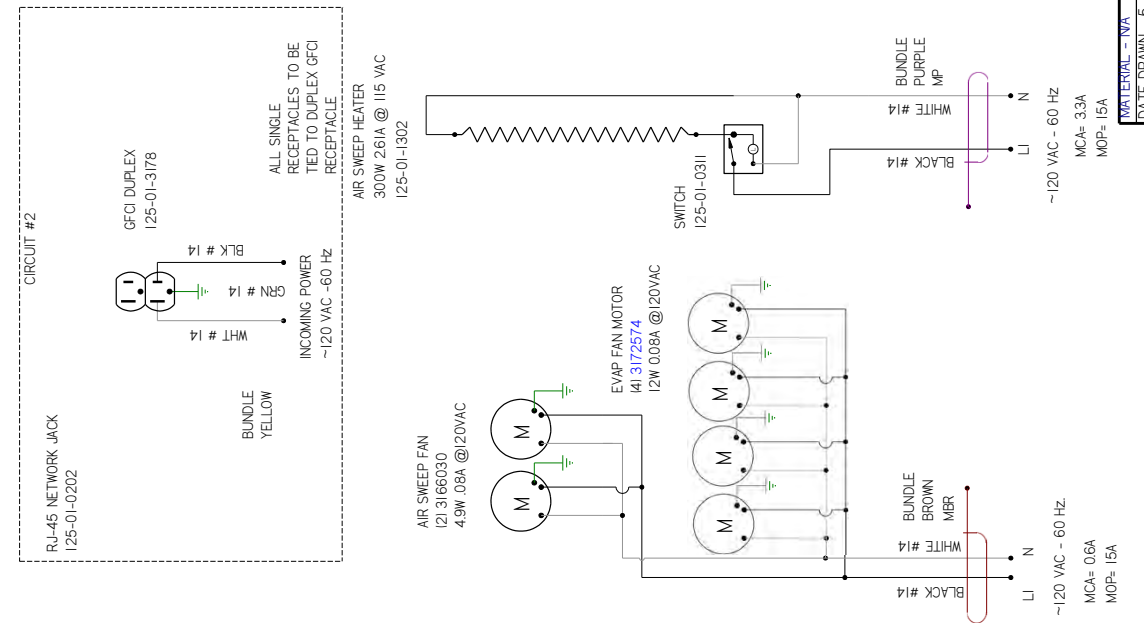
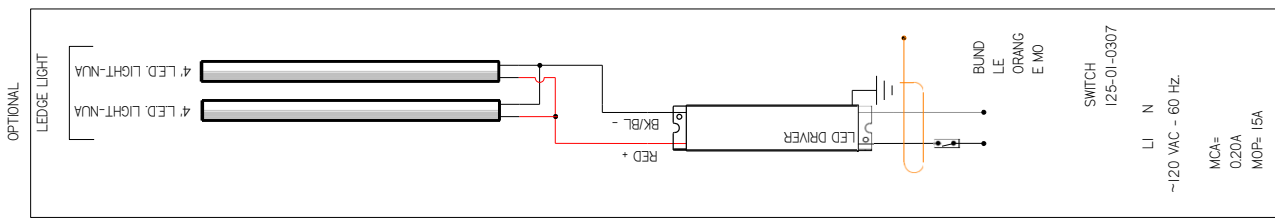
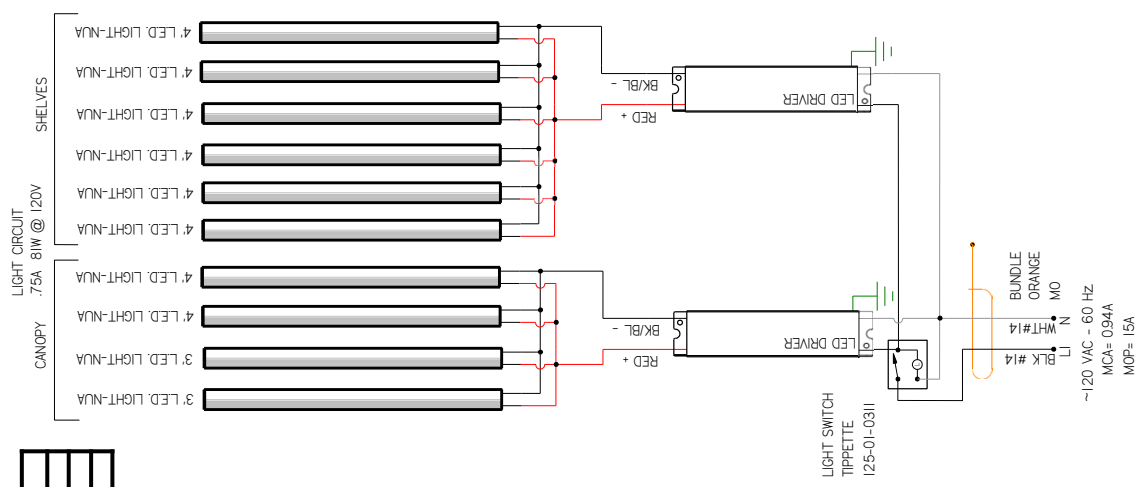

ITEM	DESCRIPTION	QTY	REV	DATE	BY
1	REVISION				
2	REVISION				
3	REVISION				
4	REVISION				
5	REVISION				
6	REVISION				
7	REVISION				
8	REVISION				
9	REVISION				
10	REVISION				
11	REVISION				
12	REVISION				
13	REVISION				
14	REVISION				
15	REVISION				
16	REVISION				
17	REVISION				
18	REVISION				
19	REVISION				
20	REVISION				

HUSSMANN
DIAGRAM-Q4-DV-8-R

DATE DRAWN - 5-12-16
 DRAWN BY - CRAIG BOOREY
 REVIEWED BY - CRAIG BOOREY
 APPROVED BY - CRAIG BOOREY
 SHEET NO. 1
 UNLESS OTHERWISE SPECIFIED DIMENSIONS ARE IN INCHES
 TOLERANCES ARE:
 FRACTIONS XX ±0.03 XXX
 DECIMALS .XX ±0.03 .XXX
 ANGLES ± 0.1°
 PROJECTION
 E

MATERIAL - N/A
 CON-CAP-0001706
 REF -

3007105

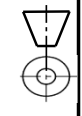

NOTES:
 CASE MUST BE GROUNDED
 WHEN PASSING WIRES THROUGH METAL HOLES A GROMMET MUST BE USED

CIRCUIT #1	LOADING
120V	
117W	
4.3	

LIGHT CIRCUIT
108A 117W @ 120V

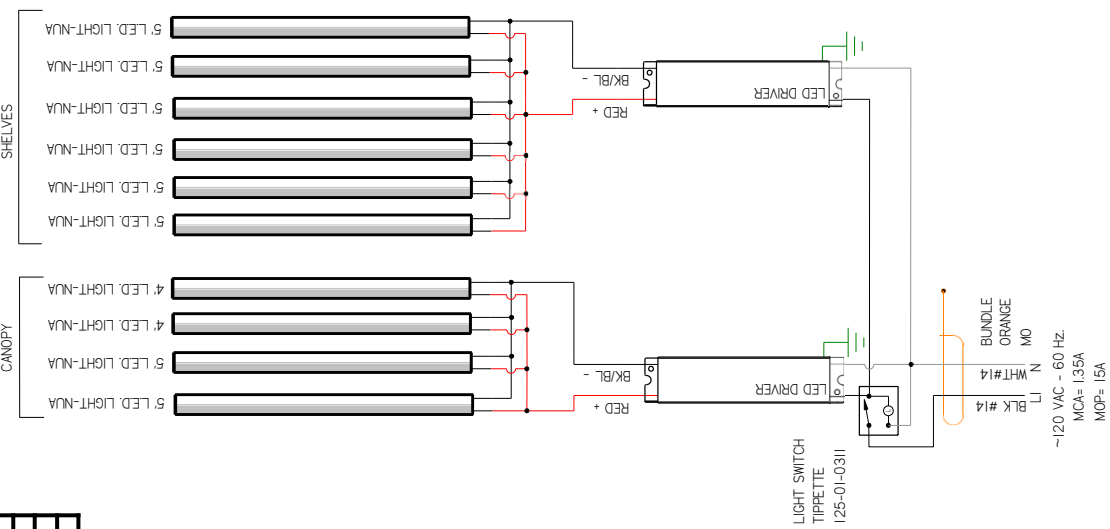

~120 VAC - 60 HZ
MCA= 135A
MOP= 15A

RJ-45 NETWORK JACK
125-01-0202

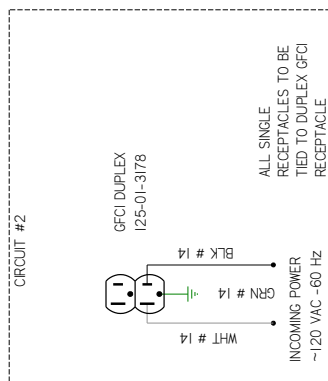

ALL SINGLE RECEPTACLES TO BE TIED TO DUPLEX GFCI RECEPTACLE

AIR SWEEP HEATER
375W 3.26A @ 115 VAC
125-01-1301

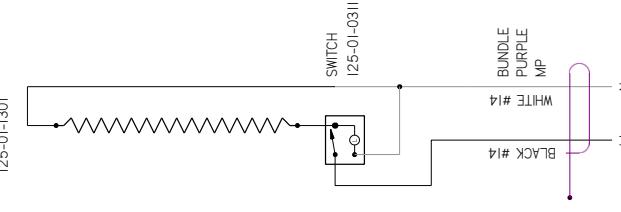

~120 VAC - 60 HZ
MCA= 0.75A
MOP= 15A

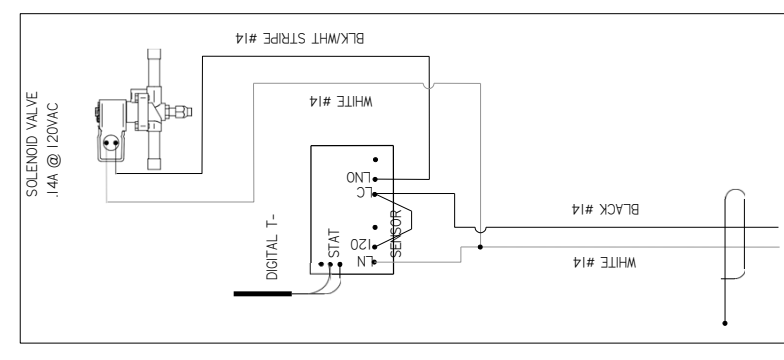

BUNDLE WHITE/BLAC
K

REV#	EN	DATE	REVISION DESCRIPTION	REV#1	CHG# BY	APPR# BY
A	ECN-CAP-0007698	2017/06/01	RELEASED TO PRODUCTION	05	05	05
B	ECN-COD-001844	2020/06/06	RE-LABELLED DIGITAL T-STAT	05	05	05
C	ECN-COD-0018272	2022/02/03	NEW LGHS	05	05	05
D	ECN-COD-0018437	2022/01/04	CHANGED A/S FAN MOTOR	05	05	05
E	ECN-COD-0018448	2023/10/02	CHANGED EVAP FANS & LIGHTS	05	05	05
F	ECN-COD-0018716	2025/11/02	NEW FAN MOTORS	05	05	05

MATERIAL - N/A
DATE DRAWN - 5-1-17
DRAWN BY - CRAIG BOOREY
REVIEWED BY - CRAIG BOOREY
APPROVED BY - CRAIG BOOREY
UNLESS OTHERWISE SPECIFIED DIMENSIONS ARE IN INCHES TO LEAST SIGNIFICANT DIGIT
DECIMALS .XX +0.3 .XXX +0.0
ANGLES ± 2°
PROJECTION
E
F

HUSSMANN
DIAGRAM-Q4-D71BV-1
OR
SHEET 1 OF 1

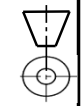

REVISION HISTORY			
REV	ECN	DATE	REVISION DESCRIPTION
A	ECN-000-0012736	3-25-21	RELEASED TO PRODUCTION
			REV BY / CHKD BY / APPR BY
			CB CB CB

CIRCUIT #1	LOADING
120V	
15A	

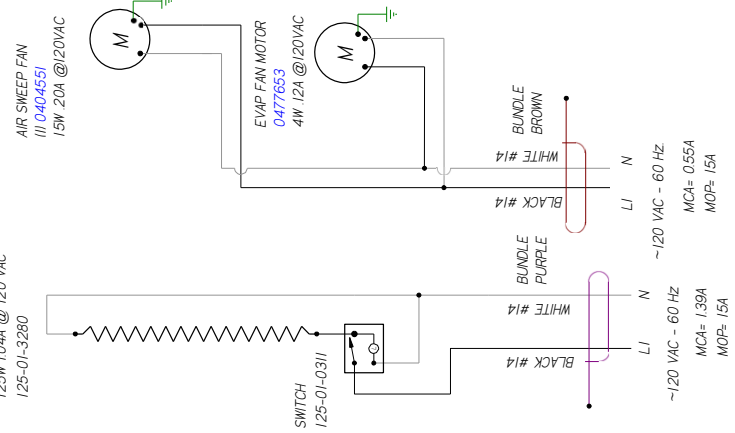
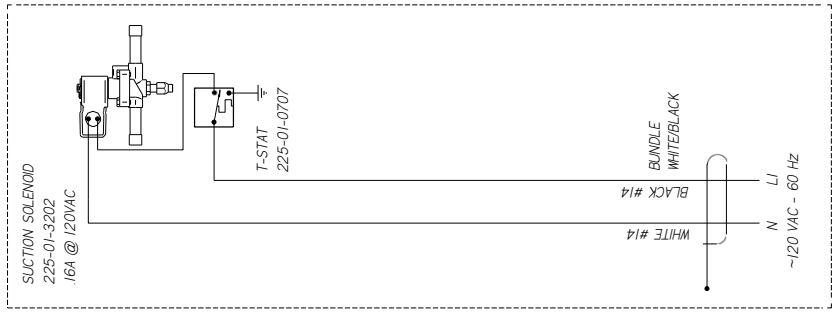
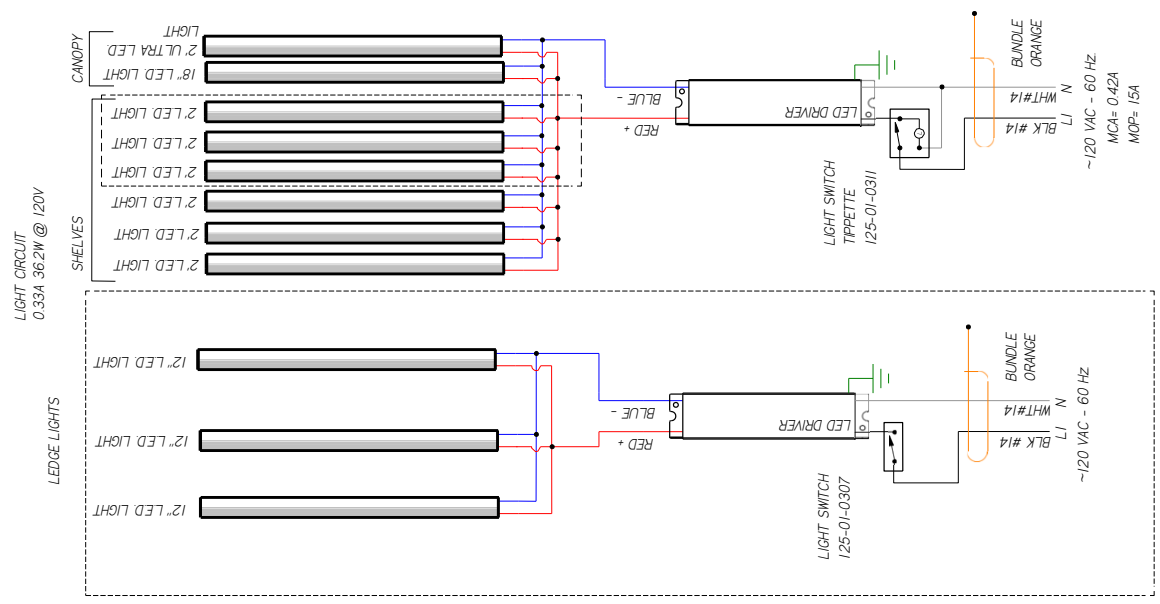
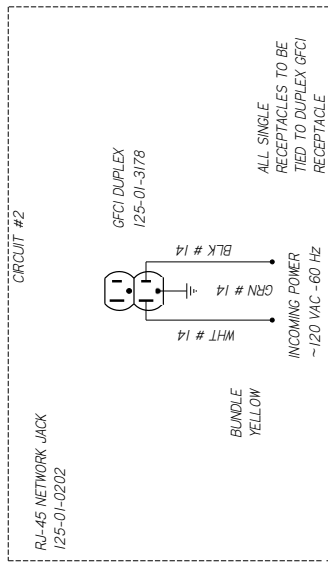

HUSSMANN

DIAGRAM-Q4-DV-45 OS-R

FACTORY 14GA WIRE
-FACTORY 10GA WIRE
-FIELD WIRE

DO NOT SCALE DRAWING
SHEET 1 OF 1

UL COLOR CODES / ABBREVIATIONS

- RED = RD
- BLACK = BK
- BLUE = BL
- YELLOW = YL
- GRAY = GR
- WHITE = WT
- GREEN = GN
- BROWN = BN
- ORANGE = OR
- VIOLET = VT

- NOTES:**
1. PRINTED DOCUMENT REQUIRED SETTING. ALL COLORS BLACK & WHITE
 2. CASE & ANY REMOVABLE PANEL WITH ELECTRICAL PARTS MUST BE GROUNDED.
 3. WHEN PASSING WIRES THROUGH METAL HOLES A GROMMET MUST BE USED

CIRCUIT #1	120V	1-1	CB
	120V	1-1	CB
	120V	1-1	CB

REV	EN	DATE	REVISION DESCRIPTION	REV BY	CHK BY	APP BY
A	ECN-CAP-0007703	20070823	RELEASED TO PRODUCTION	CB	CB	CB
B	ECN-CAD-0016837	20220107	CHANGED AS FAN MOTORS	CB	CB	CB

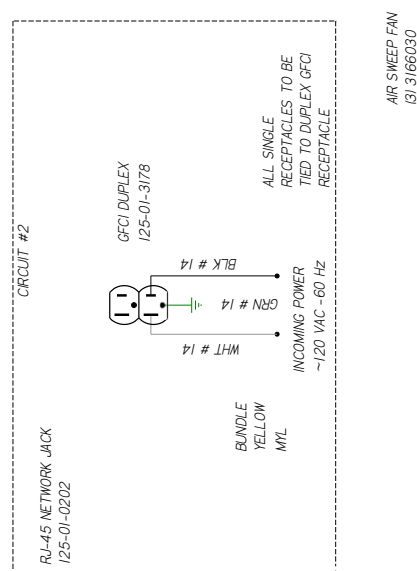
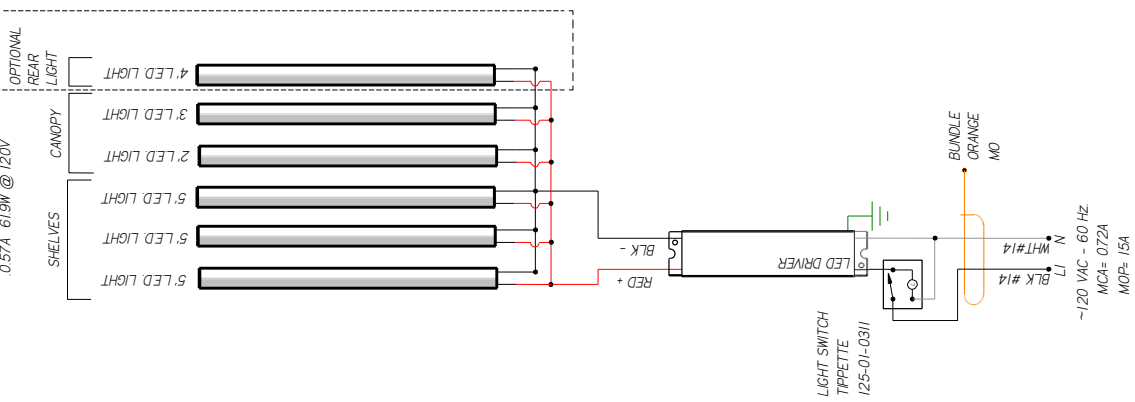

NOTES:
CASE MUST BE GROUNDED
WHEN PASSING WIRES THROUGH METAL HOLES A GROMMET MUST BE USED

MATERIAL - N/A
DATE DRAWN - 5-23-17
DRAWN BY - CRAIG BOOREY
REVISED BY - CRAIG BOOREY
APPROVED BY - CRAIG BOOREY
UNLESS OTHERWISE SPECIFIED DIMENSIONS ARE IN INCHES
TOLERANCES ARE:
DECIMALS .XX ±0.3 .XXX
±0.0 ANGL
E
PROJECTION

HUSSMANN
DIAGRAM-Q4-BV-5N
ECN-CAP-0007703
REF -
SHEET 1 OF 1
3034575 | B

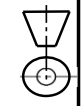

User Information

Start Up

See the merchandisers Data Sheet Set for refrigerant settings and defrost requirements. Bring merchandisers down to the operating temperatures listed on the Data Sheet.



WARNING

--LOCK OUT/ TAG OUT--

To avoid serious injury or death from electrical shock, always disconnect the electrical power at the main disconnect when servicing or replacing any electrical component. This includes, but is not limited to, such items as doors, lights, fans, heaters, and thermostats.

Shelf Configuration

Q4-DV Shelves were designed for ease of use in removing, inserting and modifying shelf configuration with a simple retaining hooks system (As Shown below)

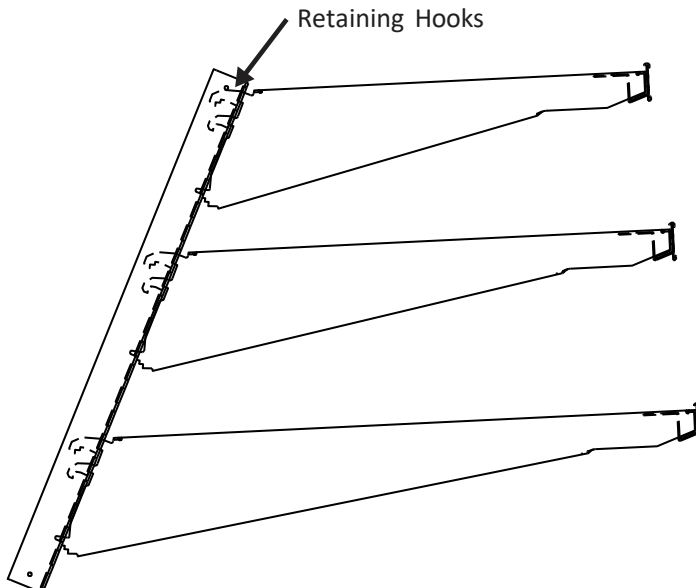

Load Limit

Each Merchandiser has a load limit. Shelf life of perishables will shorten if load limit is violated.

AT NO TIME SHOULD THE MERCHANDISER BE STOCKED BEYOND THE LOAD LIMITS INDICATED.

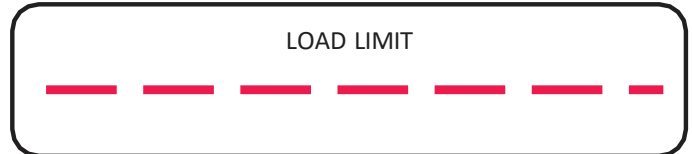

Load Limit Line

DO NOT LOAD PAST THE FOLLOWING LOAD LIMIT LINES.

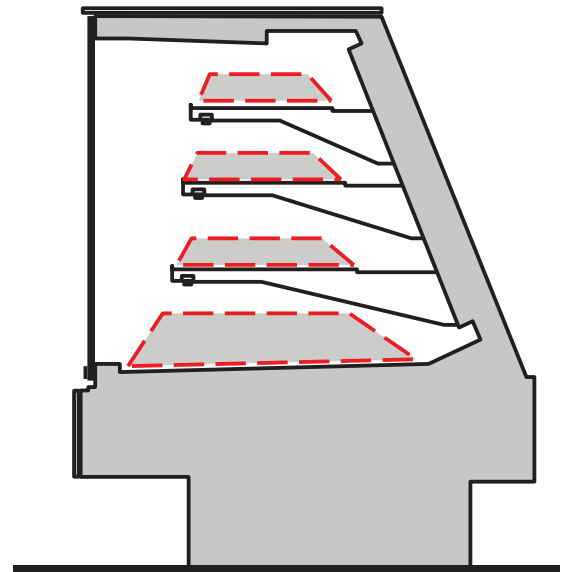

Maintenance

Case Cleaning

Long life and satisfactory performance of any equipment are dependent upon the care it receives. To insure long life, proper sanitation and minimum maintenance costs, the merchandiser should be thoroughly cleaned, all debris removed and interiors washed down, weekly.



TO PREVENT INJURY ALWAYS SHUT OFF POWER DURING CLEANING PROCESS.

Exterior Surfaces

The exterior surfaces must be cleaned with a mild detergent without chloride and warm water to protect and maintain their attractive finish. **NEVER USE ABRASIVE CLEANSERS OR SCOURING PADS.**

Cleaning Bumpers

Clean bumpers with household spray cleaners.

Cleaning Under Merchandiser

Remove lower body panels. Use a vacuum with a long wand attachment to remove accumulated dust and debris from under the merchandiser.

Cleaning Stainless Steel Surfaces

Use non abrasive cleaning materials, and always polish with the grain of the steel. Use warm water or add a mild detergent to the water and apply with a cloth. Always wipe dry after wetting.

Use non-chlorine containing cleaners such as window cleaners and mild detergents. Do not use cleaners containing salts as this may cause pitting and rusting of the stainless steel finish. Do not use bleach.

Clean frequently to avoid build-up of hard, stubborn stains. A stainless steel cleaning solution may be used periodically to minimize scratching and remove stains.

Rinse and wipe dry immediately after cleaning. Never use hydrochloric acid (muriatic acid) on stainless steel.

Interior Surfaces

The interior surfaces may be cleaned with most domestic detergents, ammonia based cleaners and sanitizing solutions that do not contain chloride with no harm to the surface.

Cleaning Coils

NEVER USE SHARP OBJECTS AROUND COILS. Use a soft brush or vacuum brush to clean debris from coils. Do not puncture Coils! Do not bend fins. Contact an authorized service technician if a coil is punctured, cracked, or otherwise damaged.

ICE in or on the coil indicates the refrigeration and defrost cycle is not operating properly. Contact an authorized Service Technician to determine the cause of icing and to make proper adjustments as necessary. To maintain product integrity, if not done so already, move all product to a cooler until the merchandiser has returned to normal operating temperatures.

Do Not Use:

- Abrasive cleaners and scouring pads, as these will damage the finish.
- A hose on lighted shelves or submerge lighted shelves in water.
- Solvent, oil or acidic based cleaners on any interior surfaces.
- A hose on LED Lights or any other electrical component.

Maintenance Cont'd

Rear Sliding Doors Cleaning:

To ensure proper sliding and eliminate potential damage, the doors must be removed and the tracks cleaned with soap and water weekly.

If, after cleaning, the rear sliding doors become too heavy or difficult to open/close, NSF/USDA H1 lubricant & FDA 21 CFR compliant Silicone Spray may be used as a lubricant on the guide tracks

1. Follow the manufacturers directions when using the spray. Hold spray can about 6 inches from the guide tracks. Starting from one end of the track and working your way to the other end, hold down the spray nozzle as you apply a light coating over the track.
2. Using a dry paper towel or rag, rub the lubricant into the tracks. If necessary, use additional paper towels or rags to wipe off any excess lubricant.

Additional Notes:

- Recommended product: Mr. Clearco Food Grade Silicone Spray -- manufactured by Clearco Products Co.
- **DANGER: DO NOT** spray directly on food products. Move food away to a safe location before using he spray
- Apply lubricant weekly, or as needed, especially after cleaning debris from the door tracks
- Should the lubricant ever need to be removed from the tracks, use only soap & water
 - **DO NOT** use acetone or any hydrocarbon-based solutions even if the manufacturer of the spray product may suggest them
 - Using such products may damage the guide track

Do:

- Remove the product and all loose debris to avoid clogging the waste outlet.
- Store product in a refrigerated area such as a cooler during the cleaning process. Remove only as much product as can be taken to the cooler in a timely manner.
- **First turn off refrigeration, then disconnect electrical power to merchandiser.**
- Thoroughly clean all surfaces with soap and hot water. Do not use steam or high pressure water hoses to wash the interior. These will destroy the merchandisers' sealing causing leaks and poor performance.
- Avoid direct contact between fan motors and cleaning or rinse water.
- Rinse with hot water, but **DO NOT** flood. Never introduce water faster than the waste outlet can drain.
- Allow merchandiser to completely dry before resuming operation.
- LED lights are magnetized to each shelf and can be removed easily for any shelf cleaning.
- After cleaning has been completed, remember to restore power back to merchandiser.



WARNING

Product will be degrade and may spoil if allowed to sit in non-refrigerated area.

Troubleshooting

Problem	Possible Cause	Possible Solution
Case temperature is too warm.	Ambient conditions may be affecting the case operation.	Check case position in store. Is the case located near an open door, window, electric fan or air conditioning vent that may cause air currents? Case must be located minimum 15 Ft away from doors or windows. Cases are designed to operate at 55% Relative humidity and a temperature of 75°F.
	Discharge air temp is out of spec.	Check evaporator fan operation. Check electrical connections and input voltage.
		Fans are installed backwards. Check airflow direction.
		Fan blades are installed incorrectly. Make sure fan blades have correct pitch and are per specification.
		Check to see that fan plenum is installed correctly. It should not have any gaps.
		Check suction pressure and insure that it meets factory specifications.
	Case is in defrost.	Check defrost settings. See Technical Specifications section.
	Product load may be over its limits blocking airflow.	Redistribute product so it does not exceed load level. There is a sticker on the inside of the case indicating what the maximum load line is.
Coil is freezing over.	Return air is blocked, make sure debris is not blocking the intake section.	
	Coil close-offs are not installed. Inspect coil to make sure these parts are on the case.	
Condensing coil or evaporator coil is clogged or dirty.	Clean coil.	
Case temperature is too cold.	The t-stat temp is set too low.	Check settings. See Technical Specifications section.
	Ambient conditions may be affecting the case operation.	Check case position in store. Is the case located near an open door, window, electric fan or air conditioning vent that may cause air currents? Case must be located minimum 15 Ft away from doors or windows. Cases are designed to operate at 55% Relative humidity and a temperature of 75°F.
Condensation on glass.	Ambient conditions may be affecting the case operation.	Check case position in store. Is the case located near an open door, window, electric fan or air conditioning vent that may cause air currents? Case must be located minimum 15 Ft away from doors or windows. Cases are designed to operate at 55% Relative humidity and a temperature of 75°F.
	Inadequate air circulation.	Check if air sweep fans are functioning, check electrical connections.
	There is not enough heat provided in the airflow.	Check if air sweep heater is functioning, check electrical connections.
	There are glass gaps on the side of the case.	See glass adjustment section.
	Glass is not completely shut.	Close glass correctly.

Troubleshooting Cont'd

Problem	Possible Cause	Possible Solution
Water has pooled under case.	Case drain is clogged.	Clear drain.
	PVC drains under case may have a leak.	Repair as needed.
	Case tub has unsealed opening.	Seal as needed.
	If the case is in a line-up, case to case joint is missing or unsealed.	Install case to case joint and seal as needed.
	Evaporator pan is overflowing (if applicable).	Check electrical connection to evaporator pan. Check float assembly, it should move freely up and down the support stem. Clear any debris.
Case is not draining properly.	Case is not level.	Level the case.
	Drain screen is plugged.	Clean drain screen and remove any debris.
	Drain or P-trap is clogged.	Clear any debris.
Frost or ice on evaporator coil.	Evaporator fans are not functioning.	Check electrical connections.
	Defrost clock is not functioning.	Case should be serviced by a qualified service technician.
	Coil is freezing over.	Return air is blocked, make sure debris is not blocking the intake section.
Coil close-offs are not installed. Inspect coil to make sure these parts are on the case.		
Lights do not come on.	Ballast/light socket wiring.	Check electrical connections. See Electrical Section and check wiring diagram.
	Ballast needs to be replaced.	Case should be serviced by a qualified service technician. See Electrical Section.
	Lamp socket needs to be replaced.	Case should be serviced by a qualified service technician.
	Lamp needs to be replaced.	See Maintenance Section.
	Light Switch needs to be replaced.	Case should be serviced by a qualified service technician.
Rear sliding doors difficult to Open or Close.	Obstruction / Debris on Door Track	Clean door and tracks. Refer to "Rear Sliding Doors Cleaning" in the Maintenance Section
	Excessive friction between door glide and track	Lubricate door tracks using recommended lubricant. Refer to "Rear Sliding Doors Cleaning" in the Maintenance Section



HUSSMANN[®]

**To obtain warranty information
or other support, contact your
Hussmann representative.
Please include the model and
serial number of the product.**

Hussmann Warranty / Technical Assistance
(800) 592-2060