

# Q3 MEAT VERTICAL MERCHANDISER

---

## U S E R M A N U A L

- Q3
- Q3-M/FV-EP-4'
  - Q3-M/FV-EP-6'
  - Q3-M/FV-EP-8'
  - Q3-M/FV-EP-10'
  - Q3-M/FV-EP-12'

# Table of Contents

<b>Notice</b>	<b>3</b>	<b>Electrical</b>	<b>25</b>
<b>General Information</b>	<b>4</b>	Electrical Info	
<b>Case Sections</b>	<b>5</b>	Merchandiser Electrical Data	25
<b>Installation</b>	<b>6</b>	Electrical Connections	25
Unloading		Field Wiring	25
Receiving Case	6	Identification of Wiring	25
Snapping Chalk Lines	6	Remove Rear Raceway	26
Placement	7	Electrical Conduit (Electrical Box)	26
Lifting / Panels		Wiring Diagram Index	27
Q3-MV Lifting and Transport Instructions	8		
Front Body Panel Install	9	<b>User Information</b>	<b>34</b>
Fasten Front Body Panel Install	9	General	
Fasten Rear Body Panel Install	9	Start Up	34
Leveling		Load Limits	34
Leveler Adjustment	10	Fault Codes	38
Shim The Case	10	Maintenance	
Joining		Case Cleaning	39
Parts List	11	Do's and Don'ts	39
Glass Adjustment	13	Daily Procedures	41
Arm Adjustment	14	Weekly Procedures	42
Q3-DV/MV Hinge Adjustment	15	OptiCool Notes	43
Joining Preparation	16	Troubleshooting	44
<b>Refrigeration</b>	<b>19</b>		
Piping			
Refrigerant	19		
Refrigerant Piping Diagram	19		
Line Sizing	19		
Oil Traps	19		
Refrigeration Spec Sheets	20		
Pipining Schematic	21		

# Notice



1. DO NOT overload or stand over top of case. Glass breakage may occur if precautions are disregarded.

\*Broken glass can cause lacerations, cuts, and puncture wounds which may result in severed arteries or tendons, amputations, eye injuries, or exposure to disease.

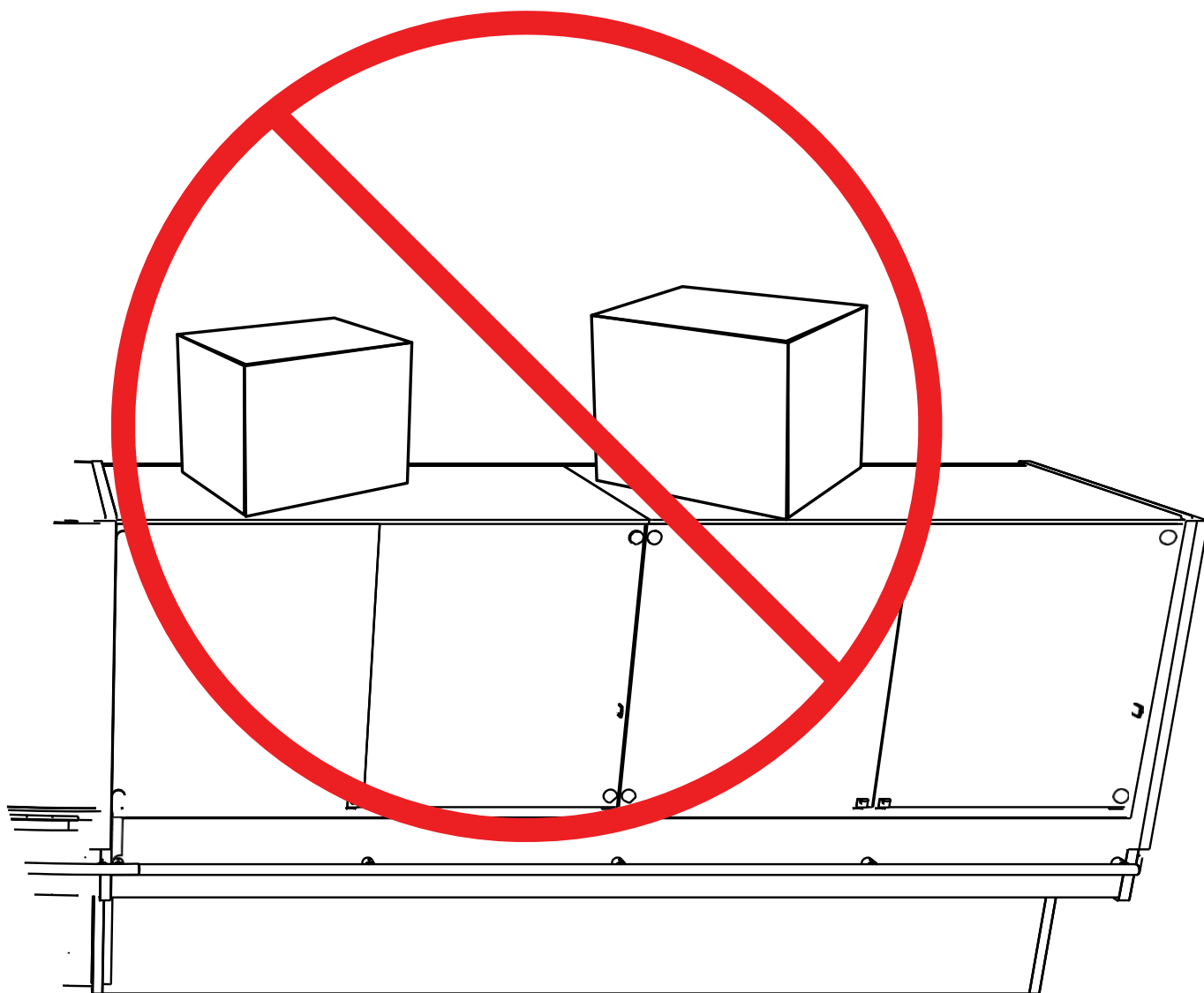

# General Information

## Case Description:

Description: Refrigerated Vertical Meat Merchandiser

**Shipping Damage:** All equipment should be thoroughly examined for shipping damage before and during unloading. This equipment has been carefully inspected at our factory and the carrier has assumed responsibility for safe arrival. If damaged, either apparent or concealed, claim must be made to the carrier Immediately.

**Apparent Loss or Damage:** If there is an obvious loss or damage, it must be noted on the freight bill or express receipt and signed by the carrier's agent; otherwise, carrier may refuse claim. The carrier will supply necessary claim forms.

**Concealed Loss or Damage:** When loss or damage is not apparent until after all equipment is uncrated, a claim for concealed damage is made. Make request in writing to carrier for inspection within 15 days, and retain all packaging. The carrier will supply inspection report and required claim forms.

**Shortages:** Check your shipment for any possible shortages of material. If a shortage should exist and is found to be the responsibility of Hussmann Chino, notify Hussmann Chino. If such a shortage involves the carrier, notify the carrier immediately, and request an inspection. Hussmann Chino will acknowledge shortages within ten days from receipt of equipment.

**Hussmann Chino Product Control:** The serial number and shipping date of all equipment has been recorded in Hussmann's files for warranty and replacement part purposes. All correspondence pertaining to warranty or parts ordering must include the serial number of each piece of equipment involved, in order to provide the customer with the correct parts.

**Location/Store Conditions:** The Q3-MV refrigerated merchandiser has been designed for use only in air conditioned stores where temperature and humidity are maintained at 80°F and 55% relative humidity or 75°F and 55% relative humidity. DO NOT allow air conditioning, electric fans, ovens, open doors or windows (etc.) to create air currents around the merchandiser, as this will impair its correct operation.

Keep this booklet with the case at all times for future reference.

**HUSSMANN®/CHINO**

A publication of HUSSMANN® Chino  
13770 Ramona Avenue • Chino, California 91710  
(909) 590-4910  
(800) 922-1919

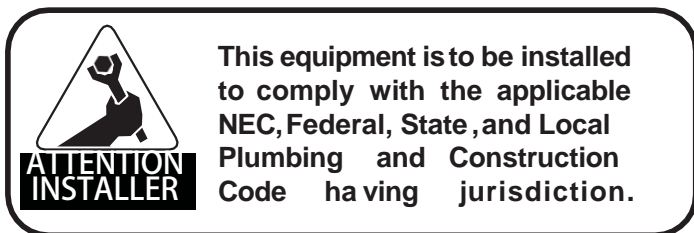

# Case Sections

**Q3-M/FV-EP** Multi-Deck Vertical Glass Service Meat Case

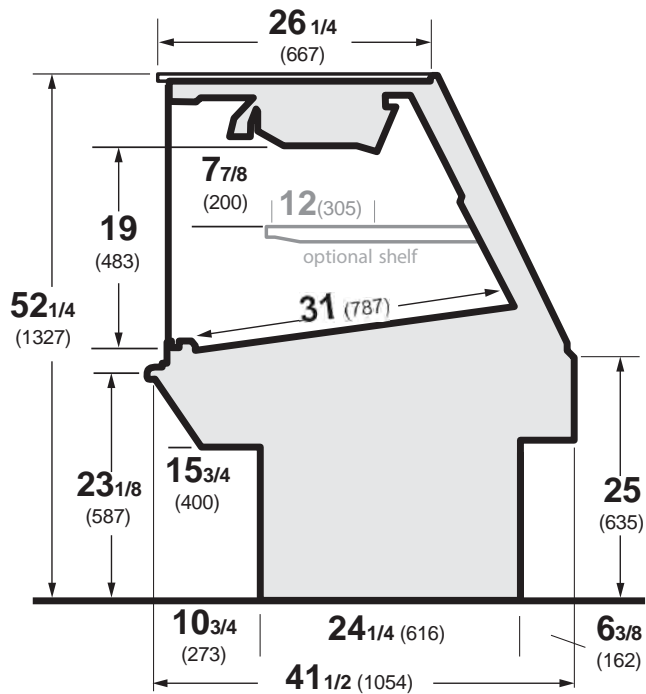

**Q3-M/FV-EP**

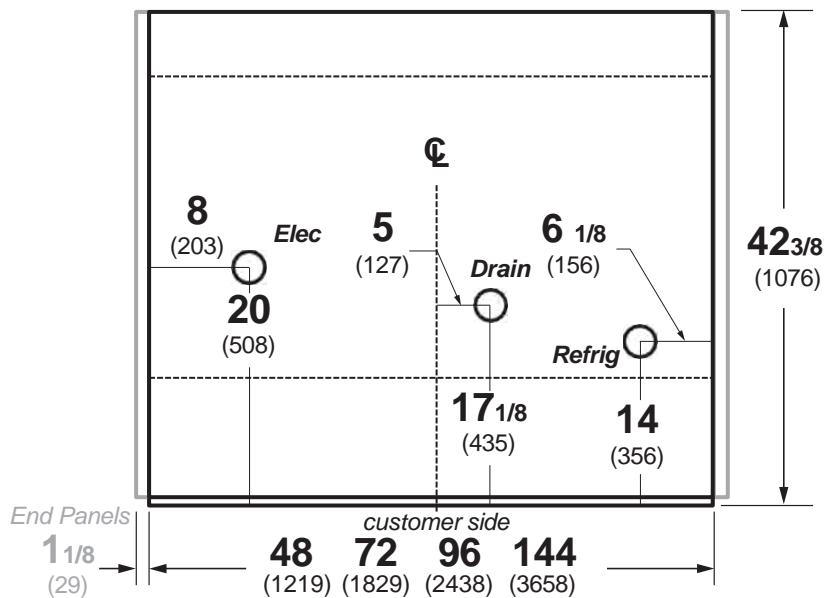

# Installation

## NOTICE

Do NOT remove Foam Blocks from shelves and glass until the merchandisers are positioned for installation. Shelves or merchandising glass may be damaged.

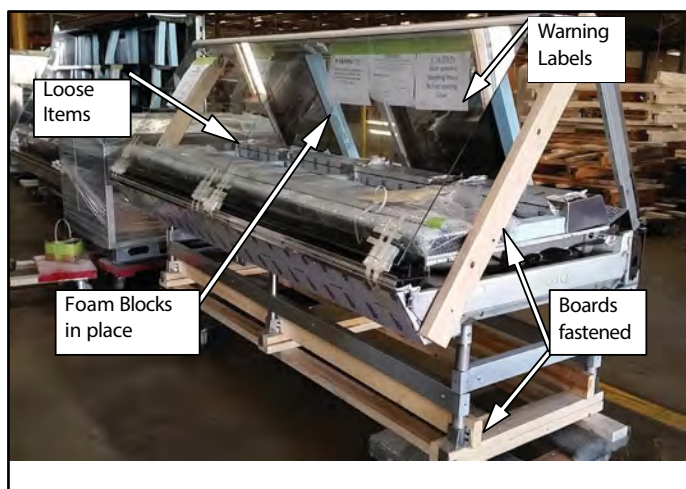

Case is to arrive at store as was shipped from factory. See reference above for proper shipment referencing. (Not actual case)

## Receiving Case

Upon receiving your new Hussmann Case all equipment should be thoroughly examined for shipping damage before and during unloading. This equipment has been carefully inspected at our factory. Any claim for loss or damage must be made to the carrier. The carrier will provide any necessary inspection reports/ or claim form. If there is obvious loss or damage, it must be noted on the freight bill or express receipt and signed by the carrier's agent; otherwise carrier may refuse claim.

## Snapping Chalk Lines

Prepare permanent positioning by marking floors with Chalk snap lines where cases are to be located. Chalk lines are to run along the base or legs of cases.

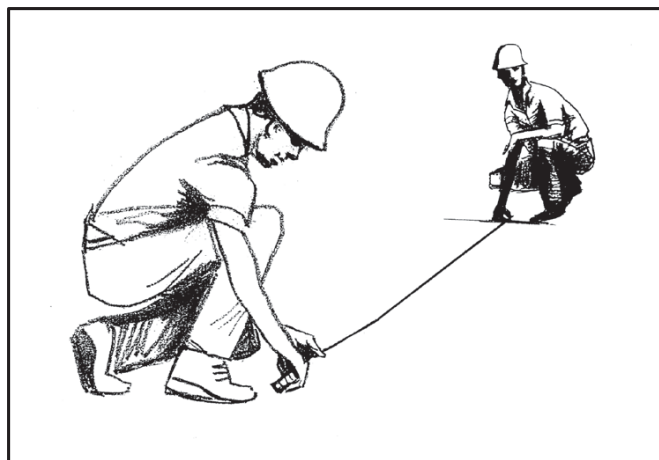

## Installation (cont'd)

### Placement

**Important:** See lifting instructions to properly lift case when being placed on dollies or permanent location. (See page 8 for Lifting Instructions.)

First remove Blocks and L Brackets around the case from pallet.

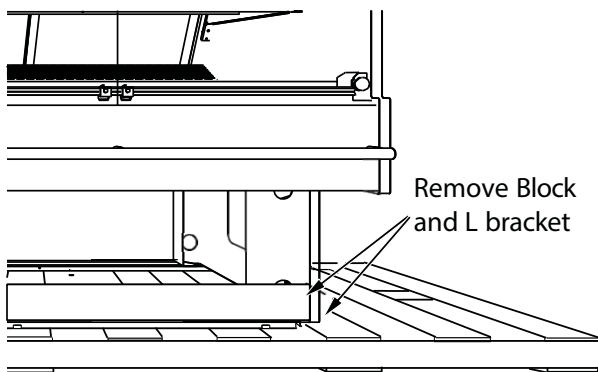

Proceed by setting forklifts under specified locations as instructed in the Lifting Instructions (pg. 8.) Be careful not to damage drains or near components when placing forks underneath case. A spotter is mandatory to ensure no damage is caused to the case. Lift case and replace with dollies, place near or in permanent location.

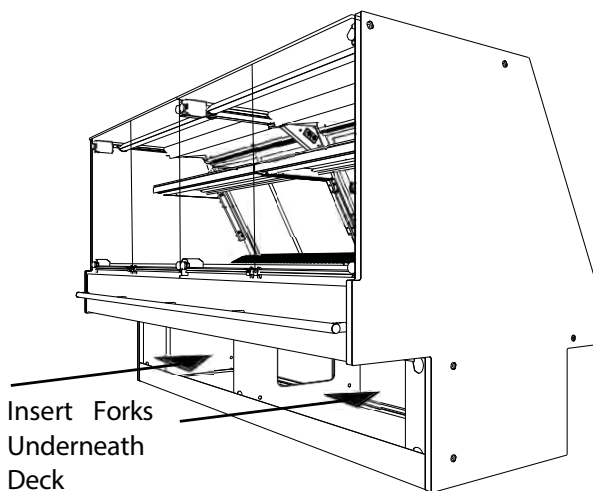

Move the fixture as close as possible to its permanent location and then remove all packaging and preparing to remove off Skid. Remove all separately packed accessories such as kits, and

panels. Check for damage before discarding packaging.

In the case a fork lift truck is not available follow the demonstration below to properly lift case using a Johnson Bar (J-Bar) to place on dollies to traffic from start point to placement area.

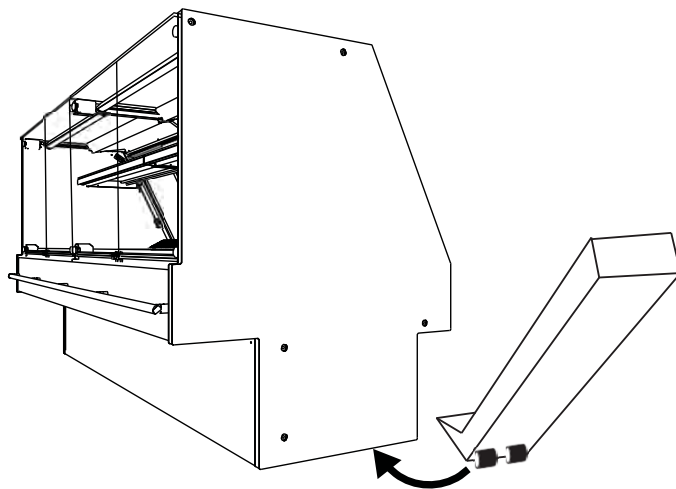

Place J-Bar underneath base of merchandiser to gain leverage, once lifted place Dollie underneath first end and slowly lower onto dollie ensuring merchandiser is placed on stable location. Proceed to opposite end and repeat.

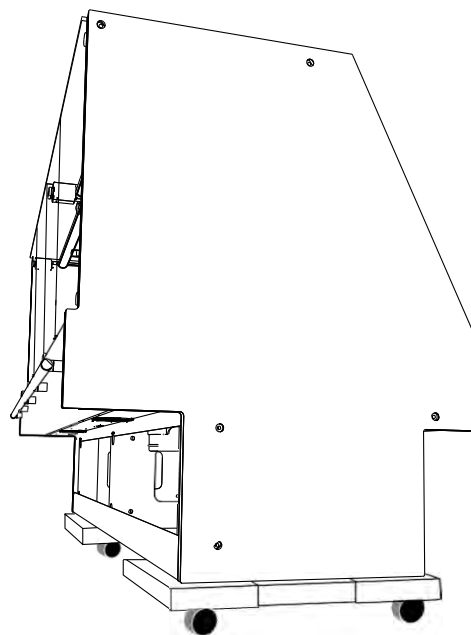

## Installation (cont'd)

### Q3-MV Lifting and Transport Instructions

1. The Q3-MV can be lifted by a forklift at typical lifting points.

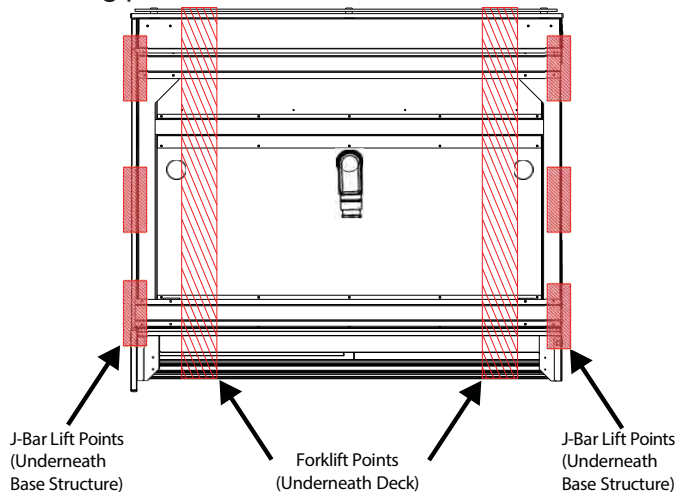

5. The Q3-MV merchandiser can be raised at one end underneath the deck with a forklift to allow the placement of rollers or dollies.
6. Evenly support the entire base structure on rollers or dollies before attempting to move. Each Base Leg must have its own dolly to properly support the case.

Lifting Points are typical and dependent upon size of case and refrigeration application, drainage configurations will call for alterations in Lifting Zones.

Below are the following drainage configurations and lifting should be altered to the expected model.

#### Q3 MV Drain Location

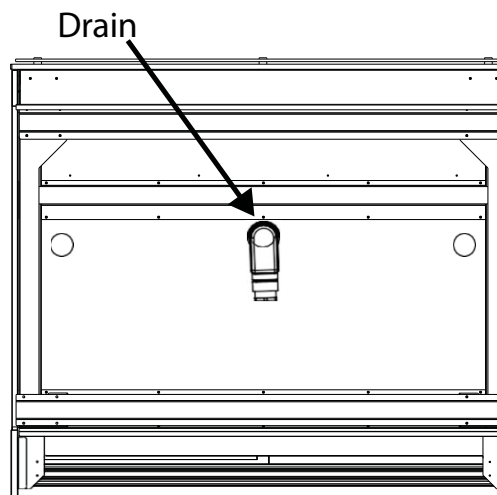

## WARNING

Improper placement of forks may damage drainage piping. Use a spotter when placing forks. Make sure that piping will not be damaged. Use J-Bars or Jacks if forks cannot be used safely

2. Ensure lower body panels are removed before lifting with a forklift. Serious damage will occur if the body panels are not removed.
3. Make sure that fork spacing and width will not damage drain or come in contact with piping, or electrical lines
4. Be sure that the forks are long enough to support beyond the center of the case but not damage near components. Check for proper balance before moving. A minimum fork length of 36" is recommended for 68" wide cases

## Installation (cont'd)

### Front Body Panel Install

A Phillips Screw Driver/Bit will be needed to install body panels.

To begin Bottom panel assembly place panel A along side the base of the case and lower panel on to support hooks along the bottom of the base (See illustration below for details).

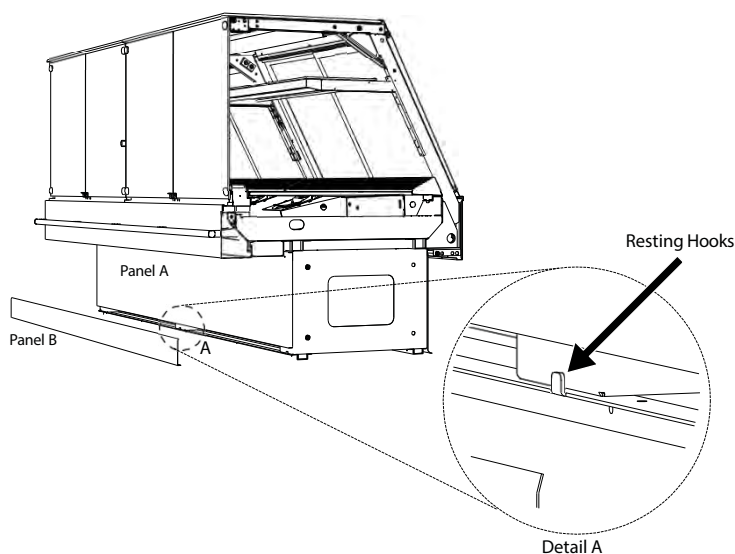

### Fasten Rear Body Panel Install

- (1) Align pre drilled holes to base of case
- (2) Secure top and bottom of rear panel using fasteners as shown below.

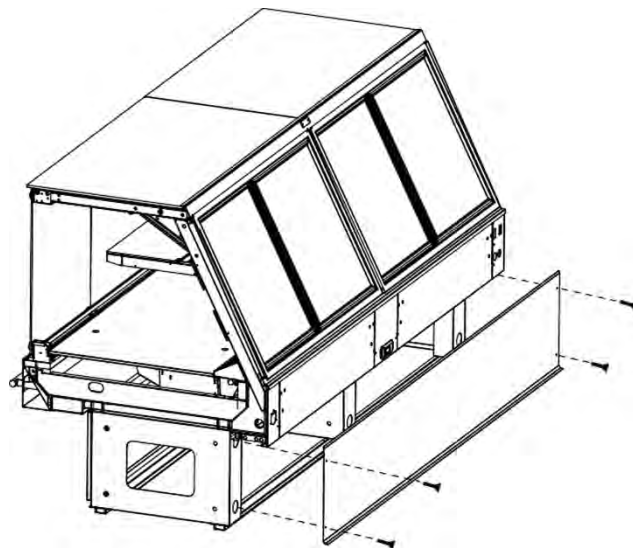

Allow front and rear body panels to slide down resting on support hooks. 2. Place L Bracket along the underside of deck to hold body panel top in place against base wall of case.

### Fasten Front Body Panel Install

- (1) Secure Panel A with top fasteners only.
- (2) Overlay Panel B to bottom of Panel A as shown in illustration below

\*Note Panel B will be attached freely with no pre drilled holes.

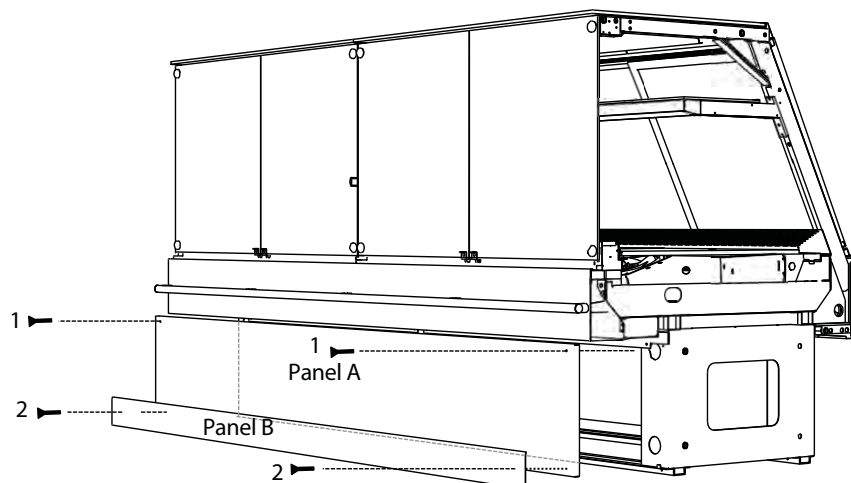

# Installation (cont'd)

## Leveler Adjustment

Position the case at the highest point. Set a long magnetized level (4ft [1220 mm] or more) on either underneath the deck or on top of the case. Ensure to level case from front to back and side to side.

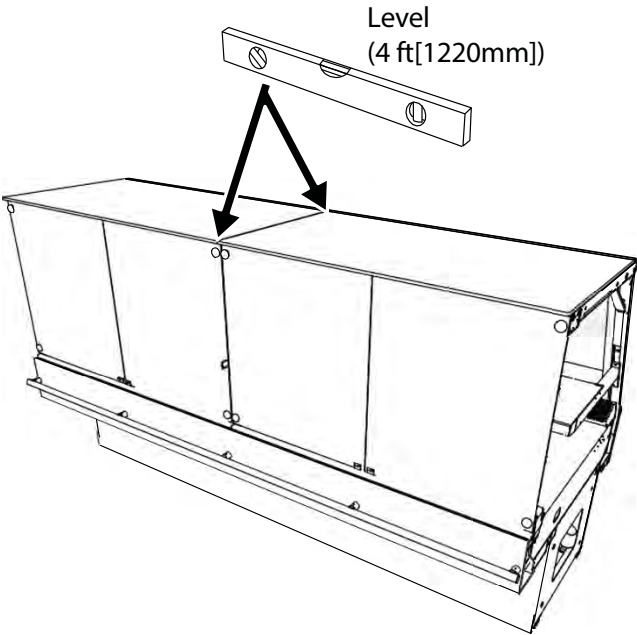

Note: To avoid removing concrete flooring, begin line up levelling from the Highest point of the store floor.

## NOTICE

Longer length cases may require shims along the center portion of the case to maintain proper case performance and drainage.

## Shim The Case

Use shims at each corner of the case to level out any discrepancies in order to optimize case performance and proper drainage.

Note: Shims are not Factory supplied. Contractor should carry available components. Metal Shims are recommended for use to eliminate any deterioration from shims over time.

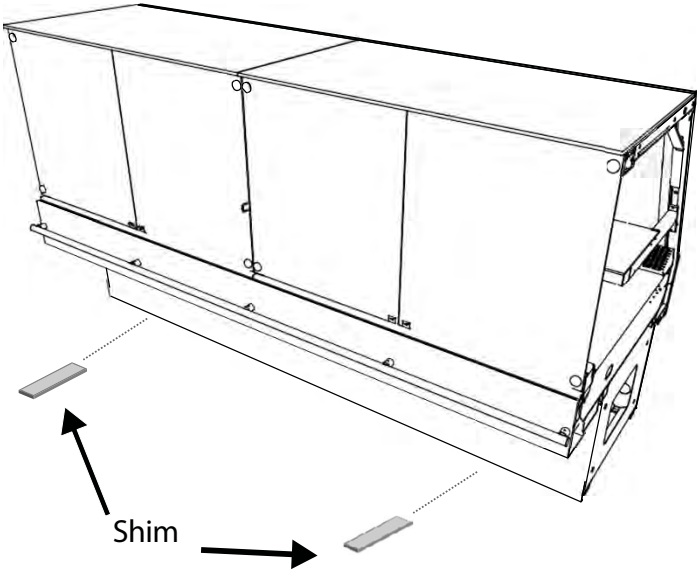

## Parts List

CHK	ITEM	PART #	QTY	KEY	PANEL USE?
<input type="checkbox"/>	TRIM A	1H63905002	1	A	NO
<input type="checkbox"/>	TRIM B	143394-2B	1	B	NO
<input type="checkbox"/> <input type="checkbox"/>	TRIM C	1H97637004 (STAINLESS) 1H97637007 (EXT COLOR)	1	C	NO
<input type="checkbox"/> <input type="checkbox"/>	TRIM D	1H97784004 (STAINLESS) 1H97784007 (EXT COLOR)	1	D	NO
<input type="checkbox"/> <input type="checkbox"/> <input type="checkbox"/>	TRIM E	2H00636004 (STR TO STR) 1H99616004 (WDG TO WDG) 1H99617004 & 1H99618004 (STRAIGHT TO WEDGE)	1	E	NO
<input type="checkbox"/>	TRIM F	2H00637004	1	F	NO
<input type="checkbox"/>	TRIM G	2H00135004	1	G	NO
<input type="checkbox"/> <input type="checkbox"/>	TRIM H	2H00649004 (STAINLESS) 2H00649005 (BLACK)	1	H	NO
<input type="checkbox"/>	WASHER , 5/16"	300-03-1315	5	J	NO
<input type="checkbox"/>	BOLT, 3/8 - 16 X 1	300-03-0845	5	K	NO
<input type="checkbox"/>	SPACER, NYLON, 5/8OD X 1/4	2H04205800	1	L	NO
<input type="checkbox"/>	ALIGNMENT PIN	0376408	2	M	NO
<input type="checkbox"/>	ALIGNMENT TAB, PLEX	070778-PLX	1	N	NO
<input type="checkbox"/>	SHIM	375-01-3004-B	20	p	YES
<input type="checkbox"/>	GASKET SEAL TAPE	225-01-0628	10 FT	Q	NO
<input type="checkbox"/>	SEALANT, BUTYL, TUBE	100-01-0121	1	R	NO
<input type="checkbox"/> <input type="checkbox"/> <input type="checkbox"/>	SEALANT, SILICONE, TUBE	100-01-0051 (CLEAR) 100-01-0063 (SILVER) 100-01-0065 (BLACK)	1	-	YES
<input type="checkbox"/>	SCREW, SELF TAP #8 X 1/2	300-03-0037	10	-	YES
<input type="checkbox"/>	VHB DOUBLE-SIDED TAPE	175-01-0562	10 FT	-	NO
<input type="checkbox"/>	COUPLING, 2" PVC	225-01-0090	1	-	YES
<input type="checkbox"/>	NIPPLE, 2" PVC	225-01-0577	1	-	YES
<input type="checkbox"/>	ADAPTER, 1-1/2" PVC	225-01-1429	1	-	YES
<input type="checkbox"/>	DRAIN TRAP, PVC	225-01-1552	1	-	YES

See page 12 for detailed illustration

SALES ORDER # \_\_\_\_\_

EXT COLOR \_\_\_\_\_

INT FINISH SS / BLACK

**\*SEE INSTALLATION GUIDE**

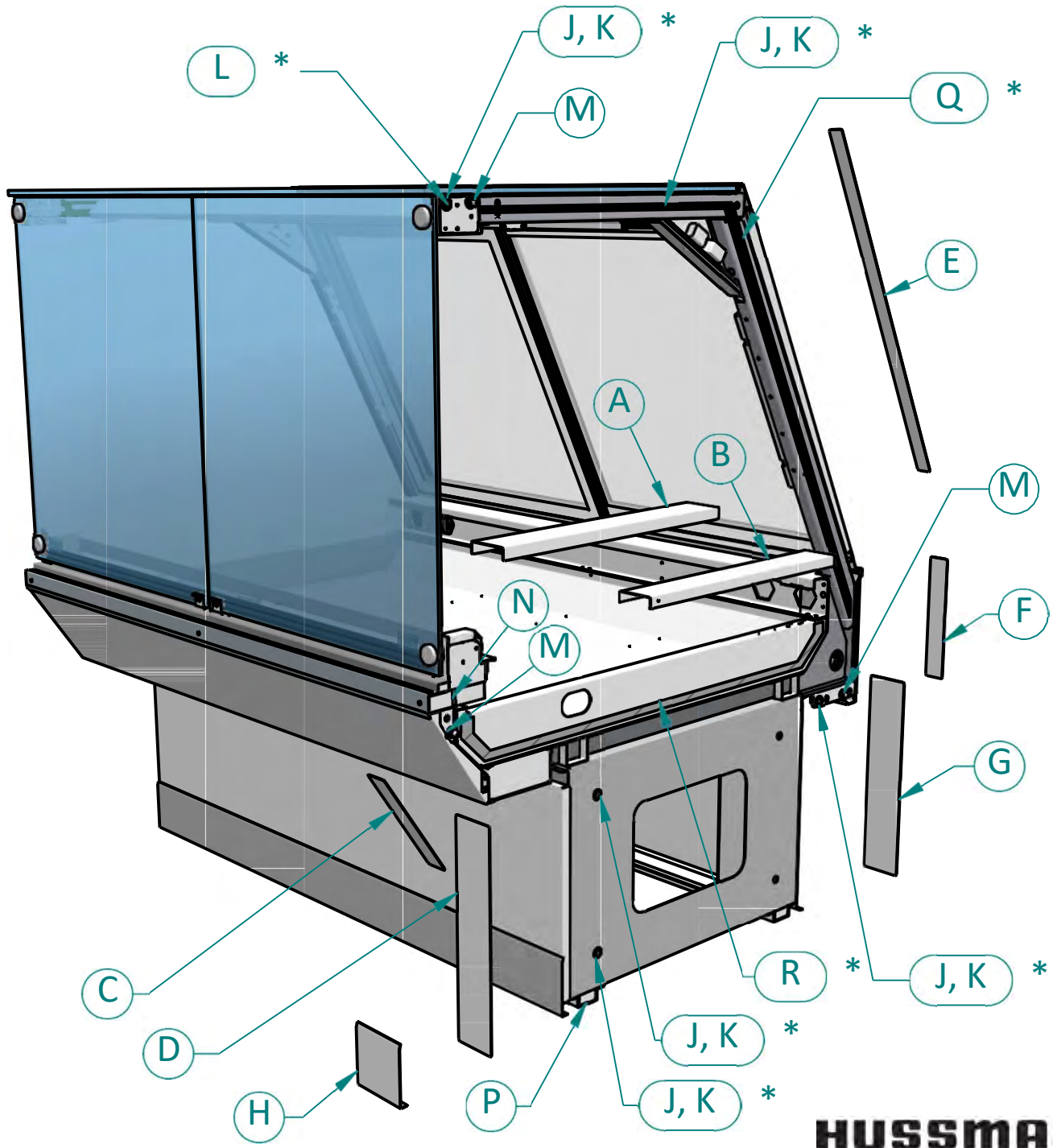

**HUSSMANN**

REV B 05/08/2015

# Installation (cont'd)

## Q3-MV Arm/Glass Adjustment

**Before any adjustments are made ensure that the case is completely level from front to back and left to right. A level case will ensure optimal alignments as well to like cases.**

Begin the Arm Adjustment process by removing the hinge covers from the front arm and deck assembly located in the front of the case.

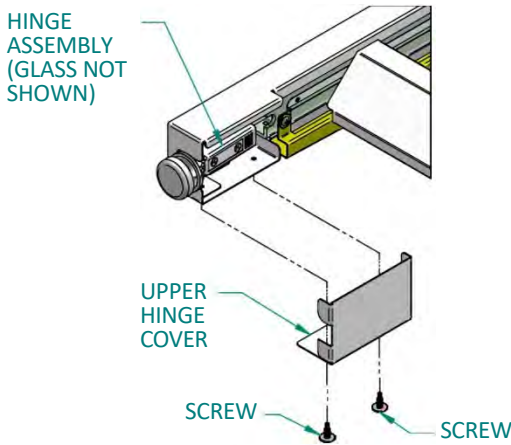

Once Hinge covers have been removed, you can now access set screws which will relieve tension from hardware to the front glass.

### UP & DOWN

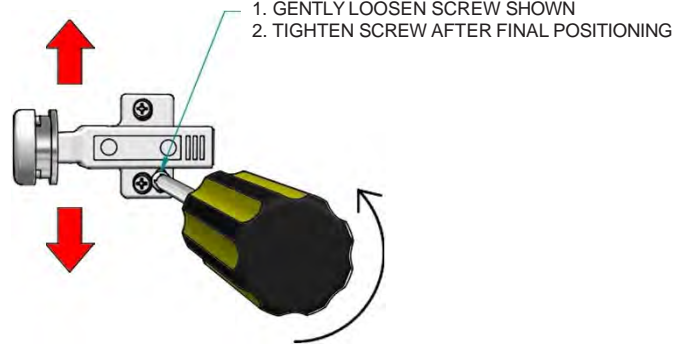

Take note that hinge set screws must remain loosened until all necessary glass and arm adjustments have been made. Only then should you re-tighten hinge setscrews.

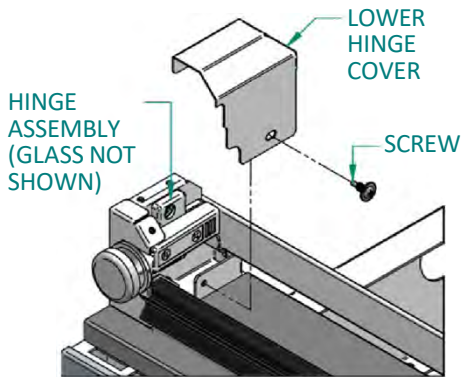

A complete overview of the Hinge adjustments are found on pg. 15

## Installation (cont'd)

Before any adjustments are made ensure that the case is completely level from front to back and left to right. A level case will ensure optimal alignments as well to like cases.

### IMPORTANT NOTE!

1. GENTLY LOOSEN SCREW SHOWN (LOOSE UNTIL ALL ADJUSTMENTS COMPLETED)
2. TIGHTEN SCREW AFTER FINAL POSITIONING

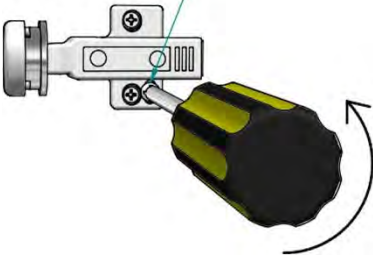

Continue the Arm Adjustment process by removing the rear doors from the frame. This can be done by lifting up and outward away from the rear door frame.

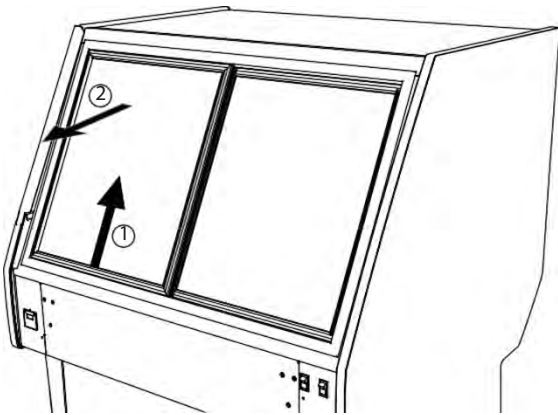

Once the door has been removed, unfasten the rear piping cover by removing the following 2 screws.

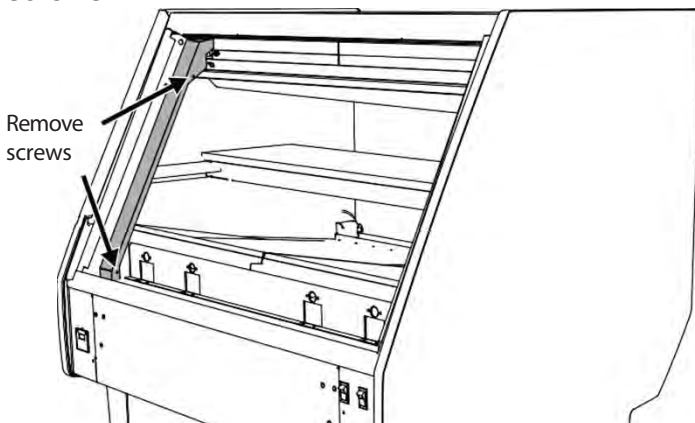

The LED light can now be removed to access the Turn Buckle.

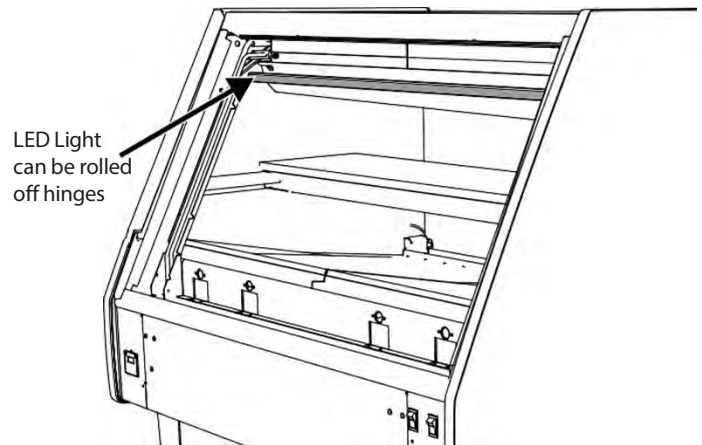

Using a 1/2" open-ended wrench, turn the turn buckle connecting rod until the level placed above the canopy arms reaches its levelled point.

- Note that some turn buckles may be reversed thread. Test the turning direction by observing the effect of turn direction.
- Upon reaching Level turn the connection rods two full rotations in the direction which raises the canopy. This will PRELOAD the arms to compensate for the weighted product.

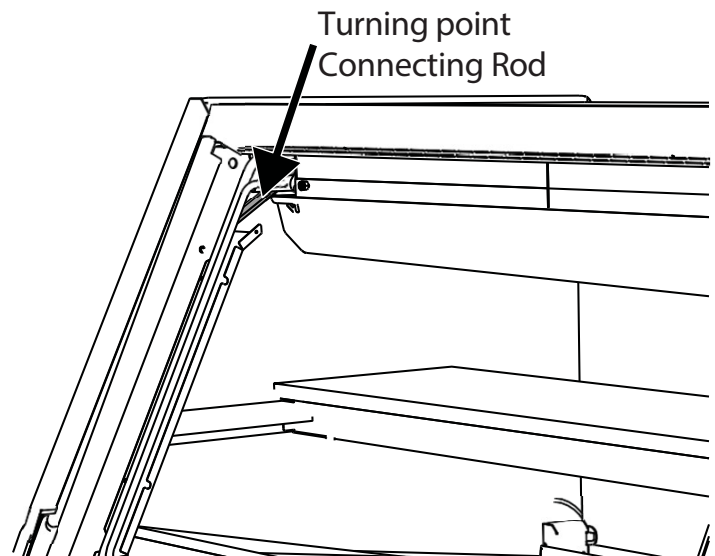

# Q3-DV/MV HINGE ADJUSTMENT



Before adjusting glass:  
• Set, Level, and Bolt together all cases  
• Double-check leveling for all cases

**IN & OUT**

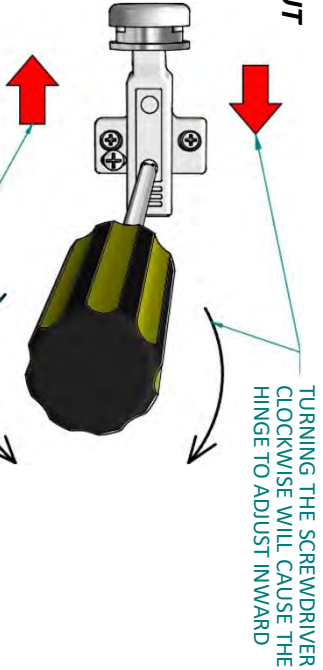

TURNING THE SCREWDRIVER CLOCKWISE WILL CAUSE THE HINGE TO ADJUST INWARD

**UP & DOWN**

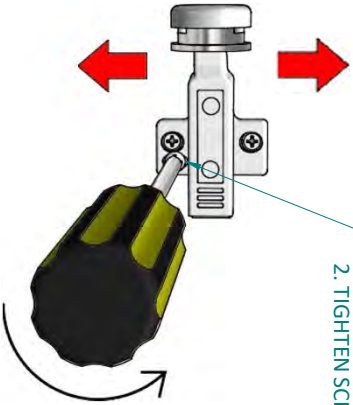

TURNING THE SCREWDRIVER COUNTER-CLOCKWISE WILL CAUSE THE HINGE TO ADJUST OUTWARD  
1. GENTLY LOOSEN SCREW SHOWN  
2. TIGHTEN SCREW AFTER FINAL POSITIONING

**LEFT & RIGHT**

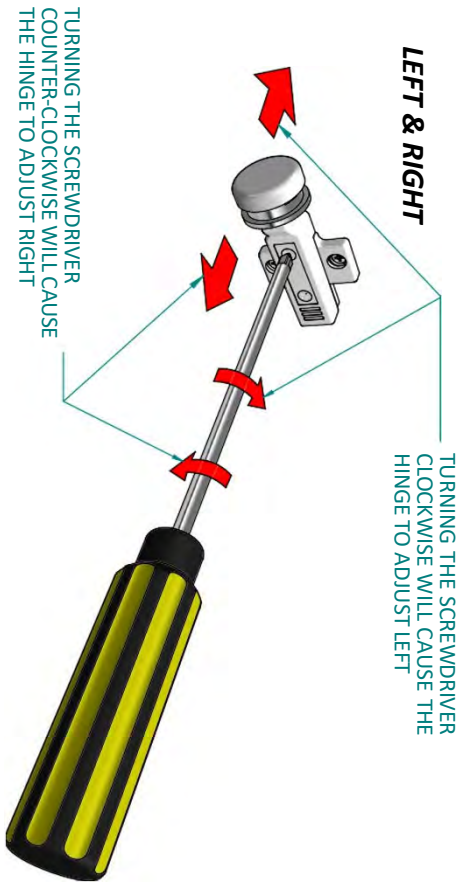

TURNING THE SCREWDRIVER COUNTER-CLOCKWISE WILL CAUSE THE HINGE TO ADJUST RIGHT

TURNING THE SCREWDRIVER CLOCKWISE WILL CAUSE THE HINGE TO ADJUST LEFT

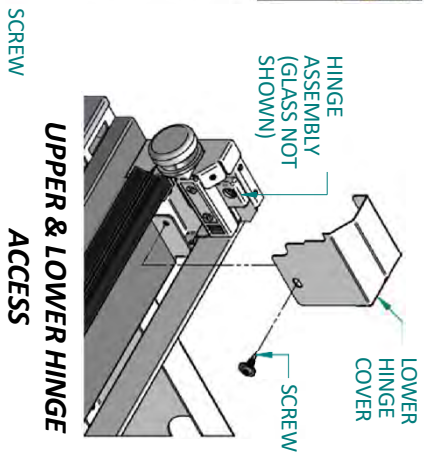
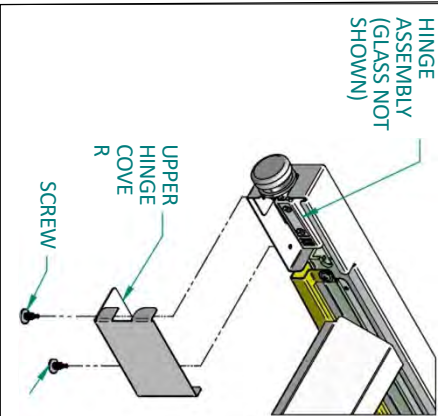

**UPPER & LOWER HINGE ACCESS**

**HUSSMANN**

# Installation (cont'd)

## Setting and Joining

The sectional construction of these models enable them to be joined in line to give the effect of one continuous display.

## Leveling

**IMPORTANT! IT IS IMPERATIVE THAT CASES BE LEVELED FROM FRONT TO BACK AND SIDE TO SIDE PRIOR TO JOINING. A LEVEL CASE IS NECESSARY TO INSURE PROPER OPERATION, WATER DRAINAGE, GLASS ALIGNMENT AND OPERATION OF THE HINGES SUPPORTING THE GLASS. LEVELING THE CASE CORRECTLY WILL SOLVE MOST HINGE OPERATION PROBLEMS.**

1. Using case blueprints, measure off and mark on the floor the exact dimensions of where the cases will sit. Snap chalk line for front and back positions of base rail or pedestal. Mark the location of each joint front and back. Find the high-est point throughout the lineup. FLOORS ARE NORMALLY NOT LEVEL! Determine the highest point of the floor; cases will be set off this point. All cases in the entire lineup must be brought up to the highest level of the case sitting at the high-est point in the lineup.

2. Set first case over the highest part of the floor and adjust base so that case is level by using shims.

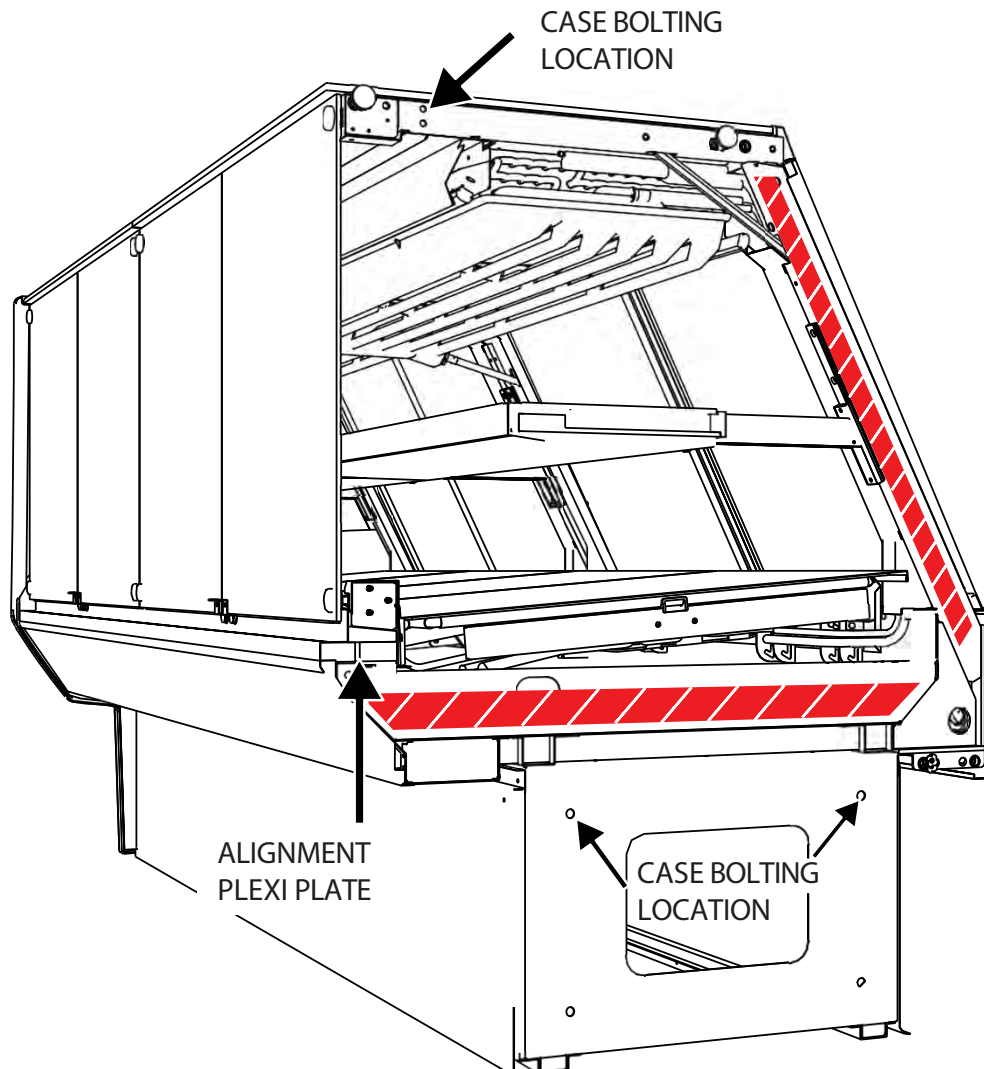

# Installation (cont'd)

3. Set second case within one foot (1') of the first case. Keep the supports along the length of the case and far end of case. Level case to the first using the instructions in step one.

4. Apply liberal bead of case joint sealant (butyl) to first case. Sealant area is shown using a dotted line in illustration. Apply heavy amount to cover entire shaded area.

5. Apply liberal bead of case joint sealant (butyl) to first case. Sealant area is shown using a striped line in illustration in page 14. Apply heavy amount to cover entire shaded area.

6. Slide second case up to first case snugly. Then level second case to the first case so glass front, bumper and top are flush.



**ATTENTION  
INSTALLER**

It is the contractor's responsibility to install case(s) according to local construction and health codes.



**CAUTION**

Do not use bolts to pull cases together.

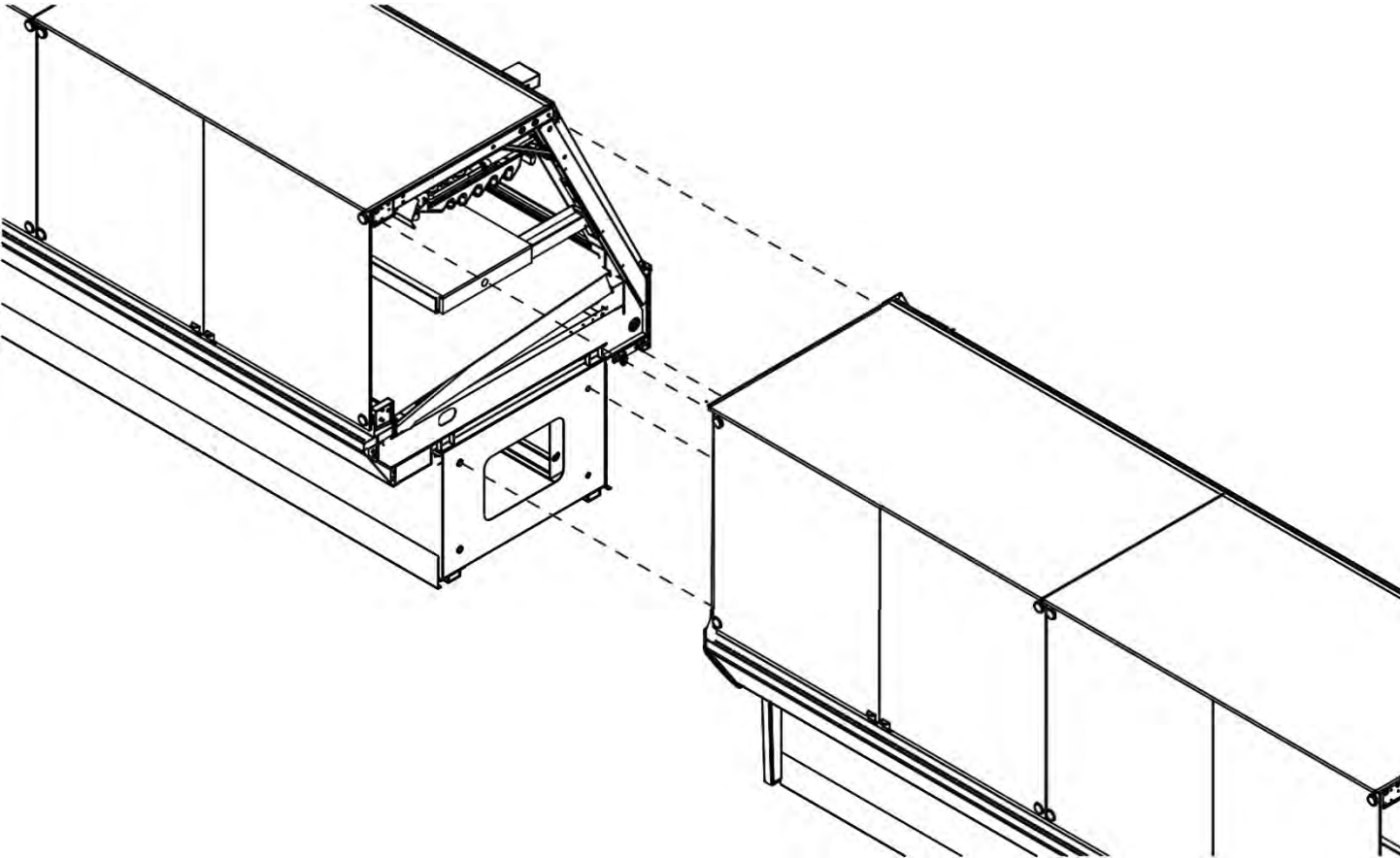

# Installation (cont'd)

7. To compress butyl at joint, use two Jurgenson wood clamps. Make sure case is level from front to back and side to side on inside bulkheads at joint.

8. Attach sections together via the bolts pictured in the illustration below.

9. Apply bead of butyl to top of bulk heads and slip on stainless steel bulkhead cap under the refrigeration piping as pictured below . Also apply silicone to seam between joints.

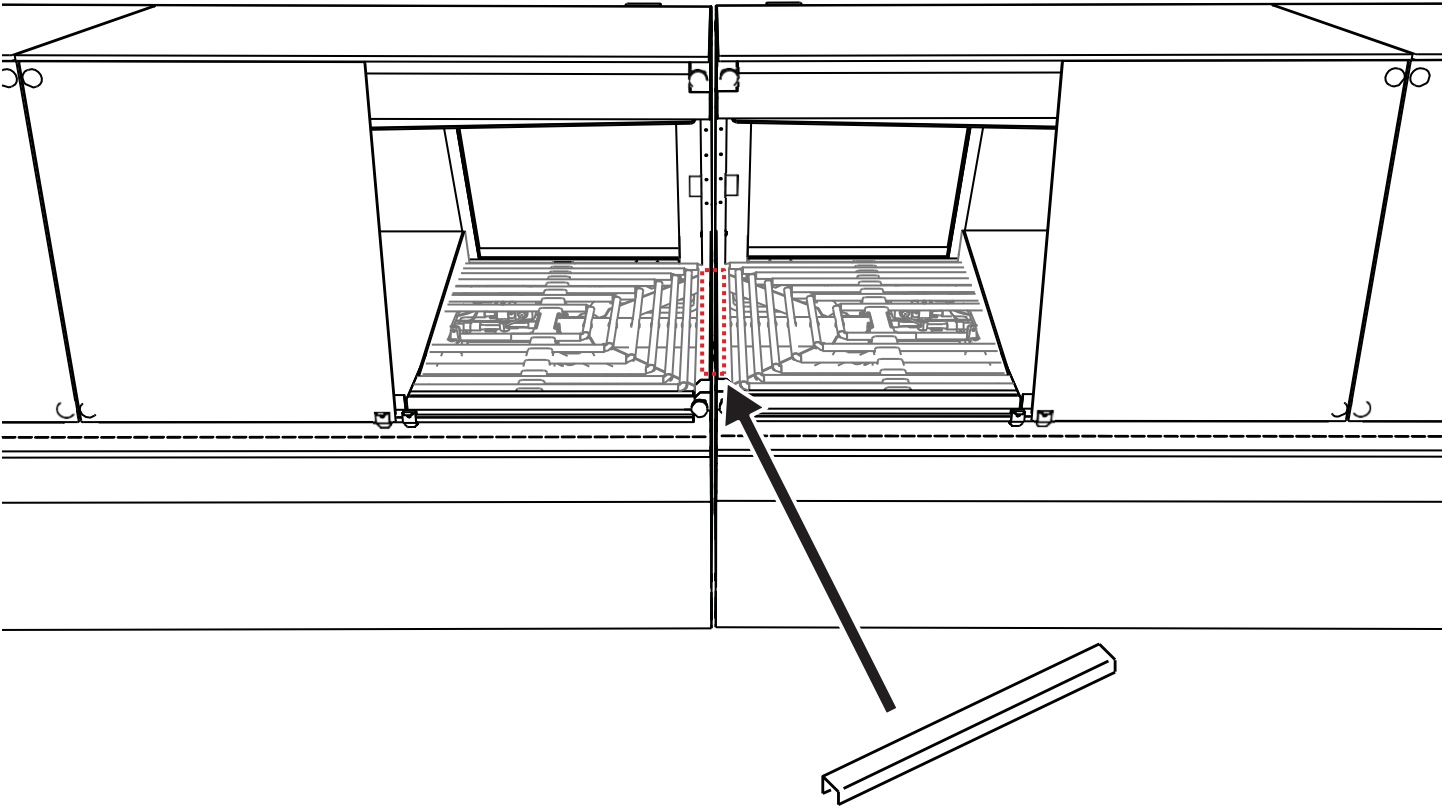

BULK HEAD JOINT CAP

# Refrigeration

## Refrigerant

The correct type of refrigerant will be stamped on each merchandiser's serial plate. The case refrigeration piping is pressurized with a nitrogen holding charge, leak tested and factory sealed. Before making refrigeration hookups, depress universal line valve (Shraeder Valve) to ensure that coils have maintained pressure during shipment. In the case pressure was not maintained contact your Hussmann Service Tech for further assistance.

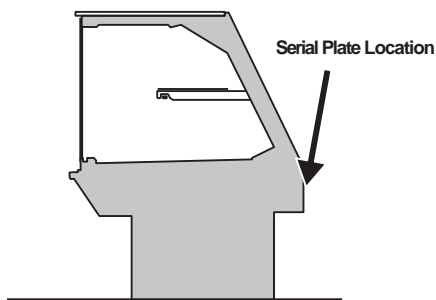

## CAUTION

Refrigeration lines are under pressure. Refrigerant must be recovered before attempting to make any connections.

## WARNING!

Do NOT apply thread sealer to ABS P-Trap.



## Refrigerant piping

The refrigerant line connections are at the right hand end of the case (as viewed from the front) beneath the display pans. The merchandiser will beforehand ensure an earlier cut hole through the pod to exit the merchandiser for the refrigeration lines. After connections have been made, make certain to seal this outlet thoroughly if not sealed at factory already. Seal both the inside and outside. We recommend using an expanding polyurethane foam insulation.

## Line Sizing

Refrigerant should be sized as shown on the refrigeration legend that is furnished for the store or according to the ASHRAE guidelines

## P-traps

P-traps must be installed at the base of all refrigerated cases. The 1 1/2" P-TRAP and threaded adapter must be installed to prevent air leakage and insect entrance into the fixture.

## Oil Traps

Oil traps must be installed at the base of all suction line vertical risers on refrigerated cases.



### ATTENTION INSTALLER

It is the contractor's responsibility to install case(s) according to local construction and health codes.

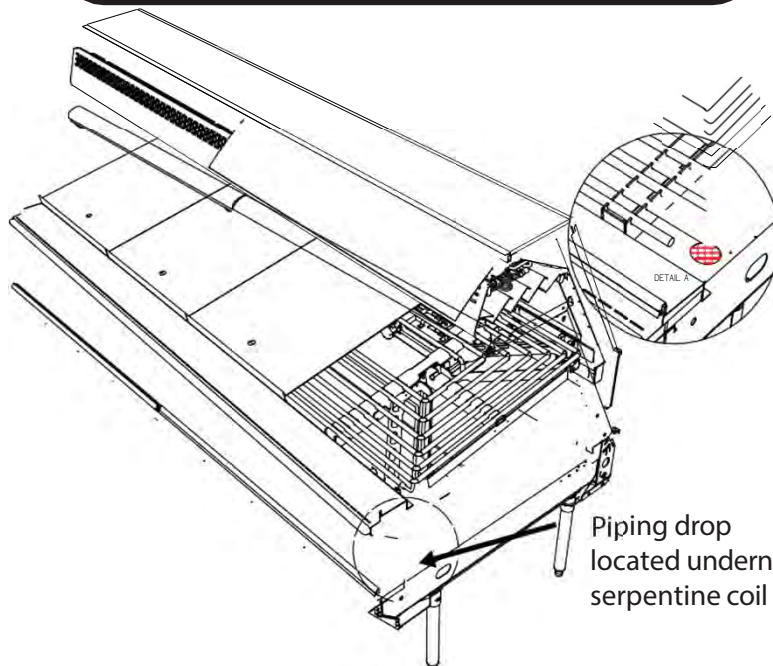

# Refrigeration Spec Sheets



MEAT/FISH SERVICE  
HUSSMANN - Q3-M/FV-EP (CHINO)

Revision Date 03/25/26

**DOE 2017 Energy Efficiency Compliant** Hussmann refrigerated merchandisers configured for sale for use in the United States meet or surpass the requirements of the DOE 2017 energy efficiency standards.

Q3-M/FV-EP Multi-Deck Vertical Glass Service Meat Case



Q3-M/FV-EP

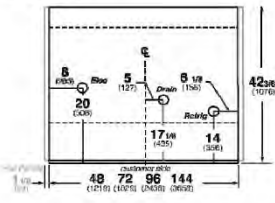

**REFRIGERATION DATA:**

CASE LENGTHS	CASE USAGE	CAPACITY *** (BTU/HR/FT) (TOTAL FOR WEDGES)		TEMPERATURE (°F)			VELOCITY (FT/MIN)
		RATING CONDITION		EVAPORATOR (°F)		DISCHARGE AIR ** (°F)	
		NSF 7	AHRI 1200	NSF 7	AHRI 1200	NSF 7	
4'-6", 8", 10", 12" NO SHELF	MEAT/FISH	275	275	28	28	33-37	50-75
4'-6", 8", 10", 12" W/ SHELF	MEAT/FISH	400	400	20	20	24-28	50-75
22.5" O W/O SHELF	MEAT/FISH	1800	1800	20	20	27-30	50-75
45" O W/ SHELF	MEAT/FISH	900	900	20	20	27-30	50-75

CASE LENGTH	EST. CHR.G.	GLYCOL (20" INLET, 6" RISE)			
		GRAVITY		SPIRAL	
		GPM	PSI	GPM	PSI
4'	1.3	0.34	1.3	0.23	0.5
6'	1.8	0.51	3.3	0.34	1.3
8'	2.2	0.68	1.5	0.45	2.4
10'	2.8	0.84	2.5	0.56	3.8
12'	3.5	1.1	1.7	0.68	5.4
22.5" O	1.0	0.3	3.6	0.2	2.5
45" O	1.0	0.2	1.4	0.1	0.6

\*\*FRONT DISCHARGE AIR MEASURED INSIDE AIR CURTAIN HONEYCOMB

\*\*\*REFRIGERATION NOTES:

- 1) BTU'S INCLUDE CANOPY LIGHTS. ADD 10 BTU'S/SHELF/FT FOR EACH SHELF (LIGHT)
- 2) ADJUSTMENTS TO CONTROL SETTINGS SHOULD BE MADE IN 1°F INCREMENTS DEPENDING UPON MEAT DEPT AMBIENT CONDITIONS
- 3) FOR SHELF APPLICATIONS IT MAY BE NECESSARY, TO INCREASE DEFROST TIME APPROXIMATELY 1 MIN PER 1°F BELOW 75°F AMBIENT
- 4) AHRI 1200 RATING POINT FOR ENERGY CONSUMPTION COMPARISON ONLY
- 5) USE DEW POINT FOR HIGH GLIDE REFRIGERANTS. CARE SHOULD BE TAKEN TO USE THE DEW POINT IN P/T TABLES FOR MEASURING AND ADJUSTING SUPERHEAT. ADJUST EVAPORATOR PRESSURE AS NEEDED TO MAINTAIN THE DISCHARGE AIR TEMPERATURE SHOWN.
- 6) THE PRINCIPAL COOLING EFFECT IN FISH CASES IS ACCOMPLISHED WITH A TRADITIONAL ICE BED. THE REFRIGERATION PRESERVES THE ICE AND MAINTAINS A COLD PROTECTIVE LAYER OVER THE PRODUCT.
- 7) RATING CONDITION IS NSF TYPE I, 75°F/65% RH

**REFRIGERATION DATA CONTINUED:**

ELEC. THERMOSTAT / AIR SENSOR SETTINGS			DEFROST TYPE	TIME (MIN)	DEFROST FREQUENCY (#/DAY)	TERM. TEMP (°F) COIL ONLY	DRIP TIME	DEFROST WATER (LBS/DAY/FT)	
LOCATION	CUT IN (°F)	CUT OUT (°F)							
GRAVITY COIL	NO	35	34	OFF TIME	50	1	45	N/A	0.9
DECK COIL	SHELF	30	29						
GRAVITY COIL	W/	27	23	OFF TIME	65	3	40	N/A	1.3
DECK COIL	SHELF	32	31						

END PANEL WIDTH KEY		
# OF END PNL'S	END PNL WIDTH	TOTAL ADDED LENGTH (IN)
1	1.125	1.125
2	1.125	2.25

**ELECTRICAL DATA:**

STANDARD FANS, HEATERS, LED LIGHTS (115 VOLT)

CASE LENGTH	AIRSWEEP FANS			CANOPY LIGHTS H.O. LED		OPTIONAL H.O. LED SHELF		MAX. LED LOAD (W/ ALL OPTIONS)		AIRSWEEP HEATERS		CONVENIENCE OUTLETS (OPTIONAL)		
	# OF FANS	AMPS	WATTS	AMPS	WATTS	AMPS	WATTS	AMPS	WATTS	AMPS	WATTS	# OUTLETS	VOLTS	AMPS
4'	1	0.04	2	0.26	30	0.22	26	0.49	56	N/A	N/A	1	115	15
6'	2	0.07	4	0.45	52	0.36	41	0.81	93	N/A	N/A	1	115	15
8'	2	0.07	4	0.53	61	0.44	51	0.97	112	N/A	N/A	1	115	15
10'	2	0.07	4	0.36	41	0.49	56	0.85	98	N/A	N/A	1	115	15
12'	3	0.11	5	0.79	91	0.67	77	1.48	169	N/A	N/A	1	115	15
22.5" O	1	0.04	2	0.08	7	0.08	11	0.15	18	N/A	N/A	1	115	15
45" O	1	0.04	2	0.08	7	0.08	11	0.15	18	N/A	N/A	1	115	15

# Refrigeration (cont'd)

REVISION HISTORY			
REV	EN	DATE	REVISION DESCRIPTION
A	ENOR0000673	7/8/15	NPL RELEASE

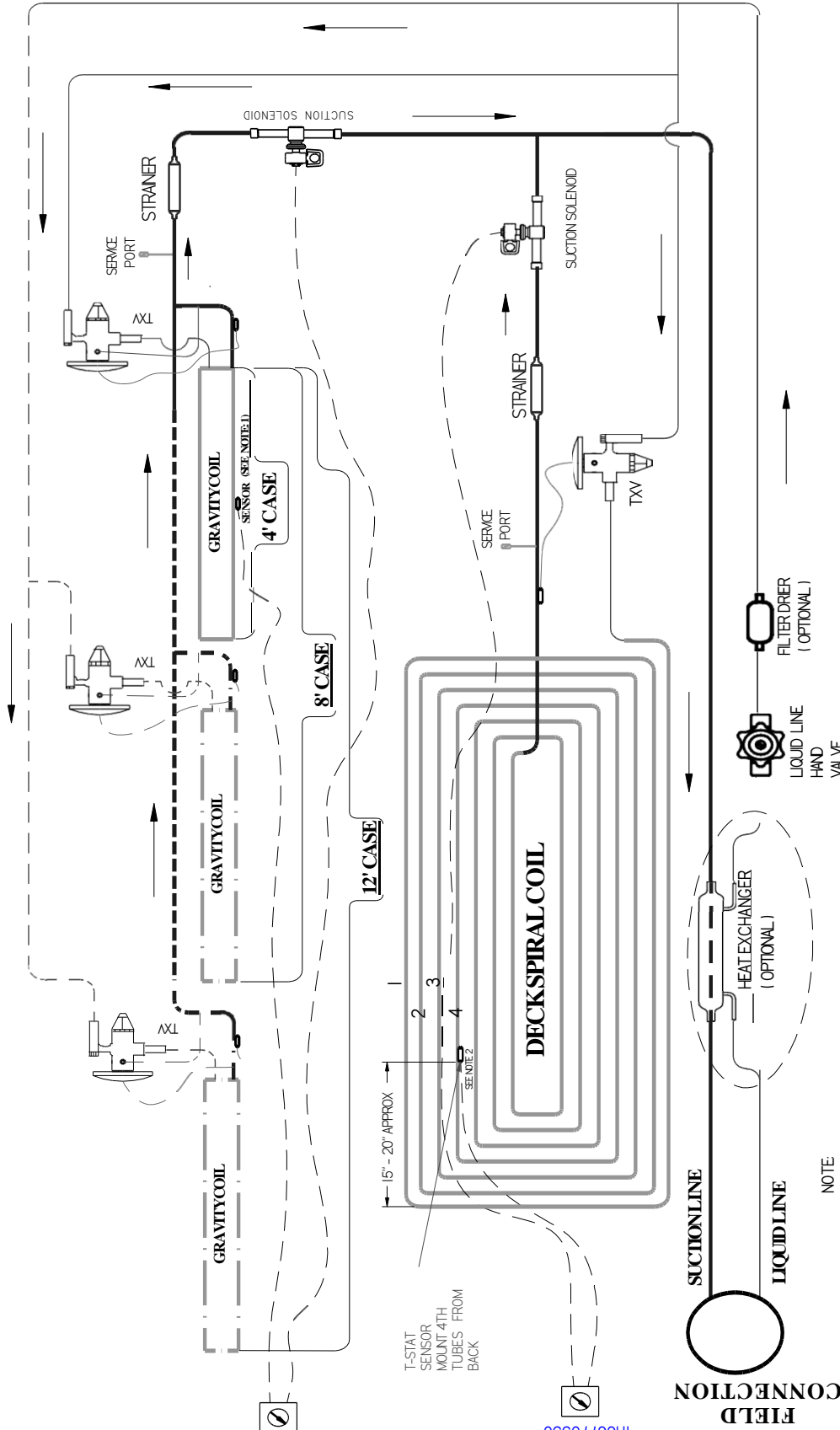

NOTE  
 1) SENSOR IS LOCATED AT APPROXIMATELY 18" - 32" FROM LEFT HAND SIDE END OF COIL, 10" BELOW BOTTOM OF COIL  
 2) SENSOR AND CLAMP SHOULD BE MOUNTED BELOW COIL TUBES TOP SURFACE

MATERIAL - NA	
MODEL BY / DWG BY: L HOANG	ENCL CAP: 0000673
CHECKED BY: L HOANG	REF -
APPROVED BY: L HOANG	SHEET 1 OF 1
DATE DRAWN: 02/18/15	UNLESS OTHERWISE SPECIFIED DIMENSIONS ARE IN INCHES
	TOLERANCES ARE:
DECIMALS: XX ±0.3 XXX	ANGLES: ±2°
±0.10	

<b>HUSSMANN</b>	
DIAGRAM-Q3-MFV-EP	
P000009	A

PROJECT  
 O N

DIGITAL T-STAT  
 IH66770550

DIGITAL T-STAT  
 IH66770550

# Refrigeration (cont'd)

See demonstrations below for detailed overview of the Q3-MV Piping schematic.

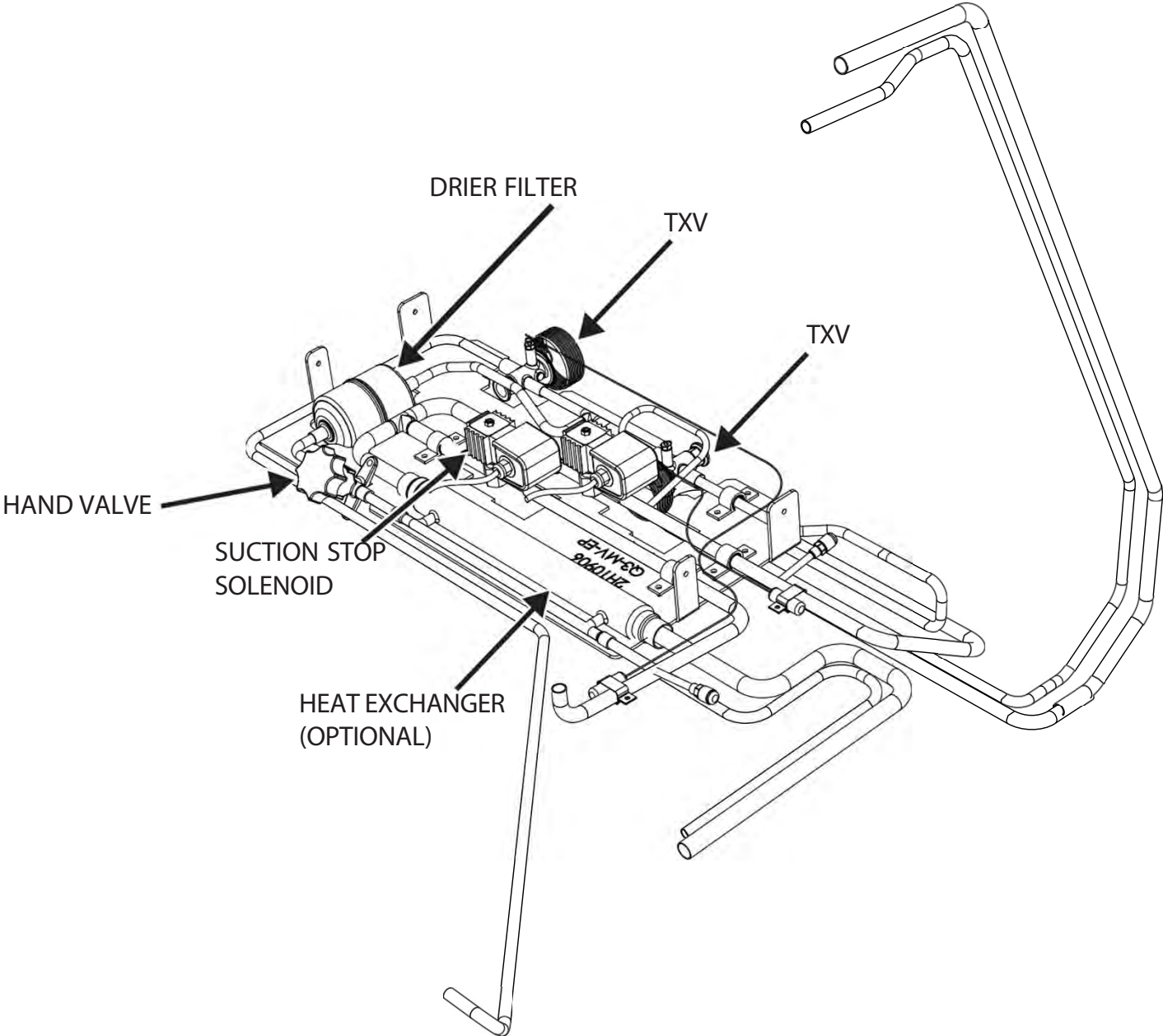

# Refrigeration (cont'd)

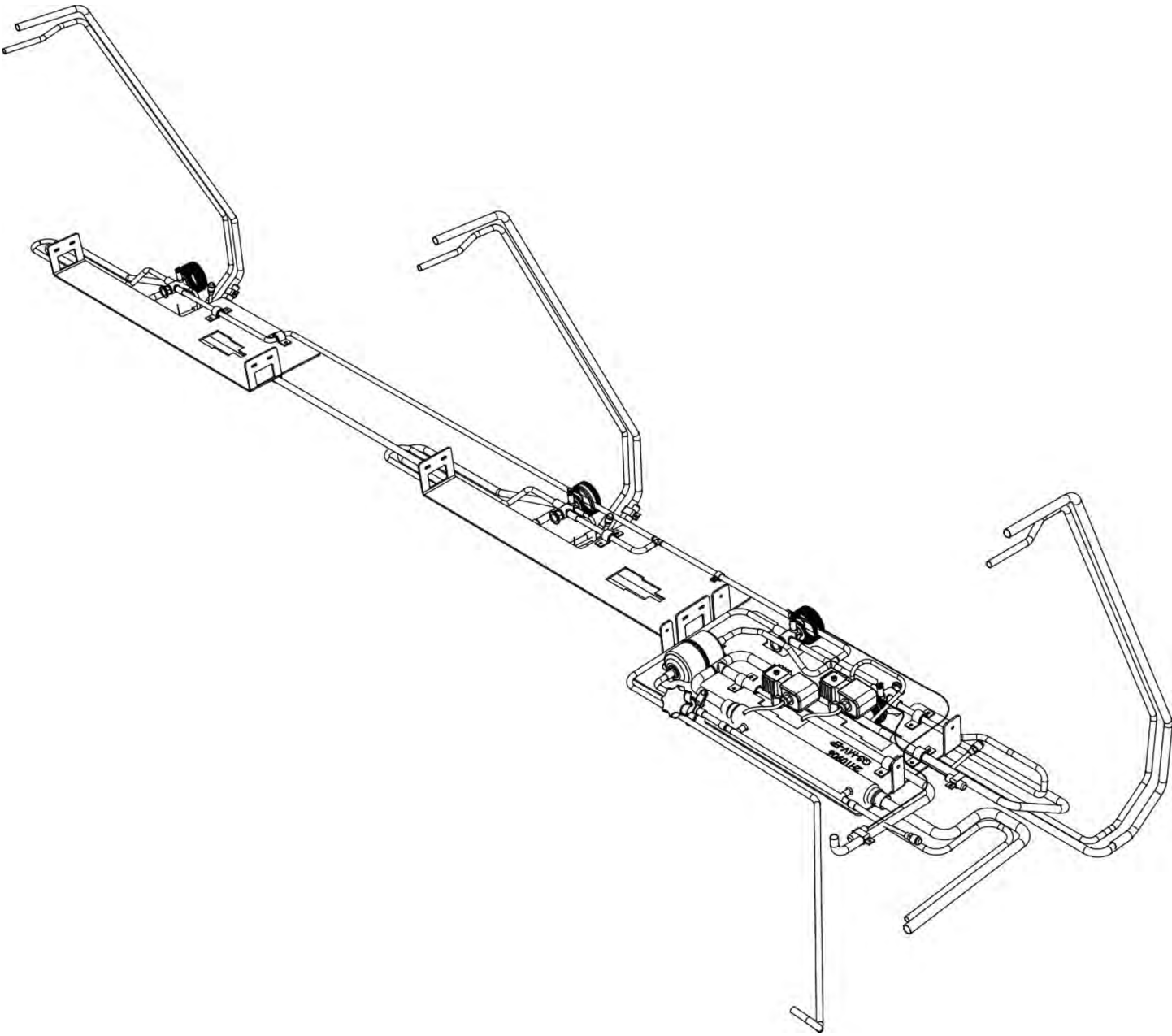

# Refrigeration (cont'd)

Piping schematic w/serpentine coils and Gravity Coil

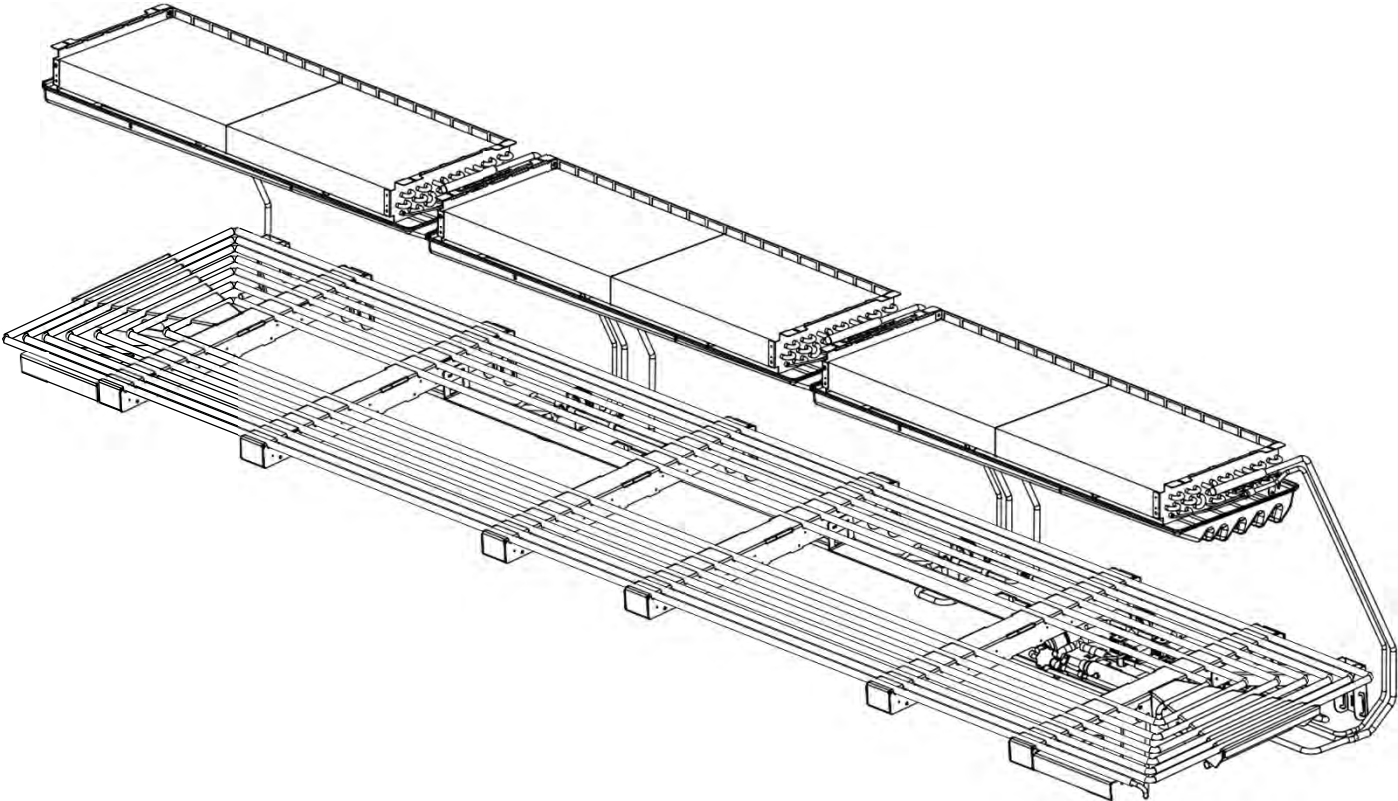

# Electrical

## Merchandiser Electrical Data

Technical data sheets are shipped with this manual. The data sheets provide merchandiser electrical data. Refer to the technical data sheets and merchandiser serial plate for electrical information.

## Electrical Connections

All wiring must be in compliance with NEC and local codes. All electrical connections including both supply circuits are to be made in the electrical J-Box.

**ALWAYS CHECK THE SERIAL PLATE FOR COMPONENT AMPERES**

## Field Wiring

Field wiring must be sized for component amperes stamped on the serial plate (refer to pg 16 for location). Actual ampere draw may be less than specified.

## Identification of Wiring

Leads for all electrical circuits are identified by colored plastic bands. These bands correspond to the color code sticker (shown below) located inside the merchandiser's wireway cover.

WARNING

--LOCK OUT/TAG OUT--

To avoid serious injury or death from electrical shock, always disconnect the electrical power at the main disconnect when servicing or replacing any electrical component. This includes, but is not limited to, such items as doors, lights, fans, heaters, and thermostats.

## WIRING COLOR CODE

Leads for all electrical circuits are identified by a colored plastic band: neutral wire for each circuit has either white insulation or a white plastic sleeve in addition to the color band.

- |   |  |
|---|--|
| Pink.....Refrig, Thermostat Low Temp<br>Light Blue..Refrig, Thermostat Norm Temp<br>Dark Blue..Defrost Term, Thermostat<br>Purple.....Condensate Heaters<br>Brown.....Fan Motors<br>Green*.....Ground | Orange OR<br>Tan.....Lights<br>Maroon..... Receptacles<br>Yellow..... Defrost Heaters 120V<br>Red.....Defrost Heaters 208V<br>*Either Colored Sleeve or Colored Insulation |
|---|--|

ELECTRICIAN NOTE: Use proper conductor wire only.

MERCHANDISER MUST BE GROUNDED

**These are marker colors, wire may vary.**

# Electrical Cont'd

## Remove Rear Raceway

The Merchandisers Electrical access is located at the rear of the case. Fasteners must be removed in order to gain access. See illustration below.

Remove Rear Raceway from rear of case.

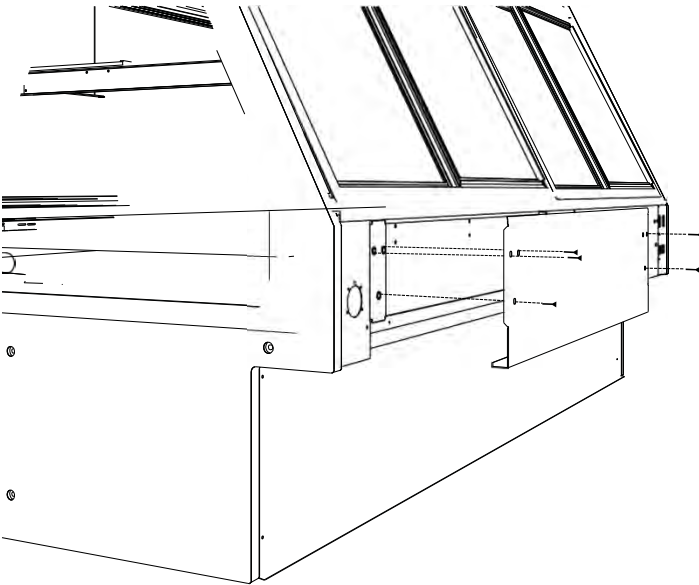

## Electrical Conduit (Electrical Box)

The Merchandisers Electrical conduit can be found inside the compartment at the rear. Removing the raceway will gain access to the electrical components inside the J-Box allowing any maintenance necessary.

Electrical Conduit

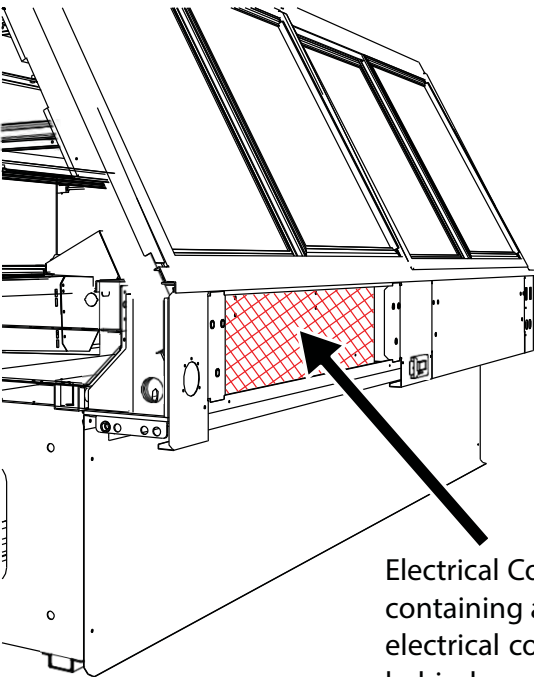

Electrical Conduit containing all necessary electrical components behind rear raceway cover

---

# Wiring Diagram Index

---

<b>Q3-MF/V-EP-4R MEAT</b>	<b>4'</b>	<b>3062745</b>
<b>Q3-MF/V-EP-6R MEAT</b>	<b>6'</b>	<b>3062747</b>
<b>Q3-MF/V-EP-8R MEAT</b>	<b>8'</b>	<b>3062748</b>
<b>Q3-MF/V-EP-10R MEAT</b>	<b>10'</b>	<b>3045986</b>
<b>Q3-MF/V-EP-12R MEAT</b>	<b>12'</b>	<b>3062749</b>
<b>Q3-MF/V-EP-45OR MEAT</b>		<b>3095452</b>

CIRCUIT #1

DNV			
120V			
L1	U14		

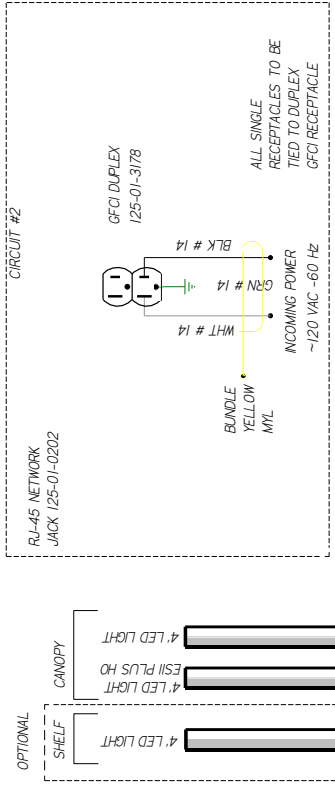

LIGHT CIRCUIT  
.38A 4I5W @ 120V

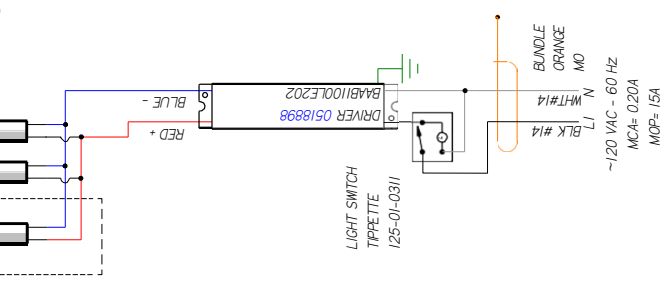

AIR SWEEP FAN  
3168337  
4.2W 008A @120VAC

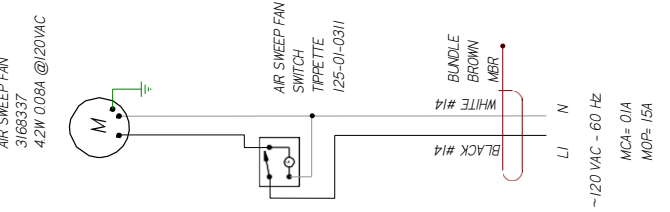

REVISION HISTORY

REV	EN	DATE	REVISION DESCRIPTION	REV BY	CHK BY	APP BY
A	EVN	2018/05/01	RELEASED TO PRODUCTION	CB	CB	CB
B	EVN	2020/03/02	RELABELED DIGITAL T-STAT	CB	CB	CB
C	EVN	2023/02/02	NEW AIR SWEEP FAN	AL	CB	CB

GRAVITY COIL  
SOLENOID VALVE  
1/4A @ 120VAC

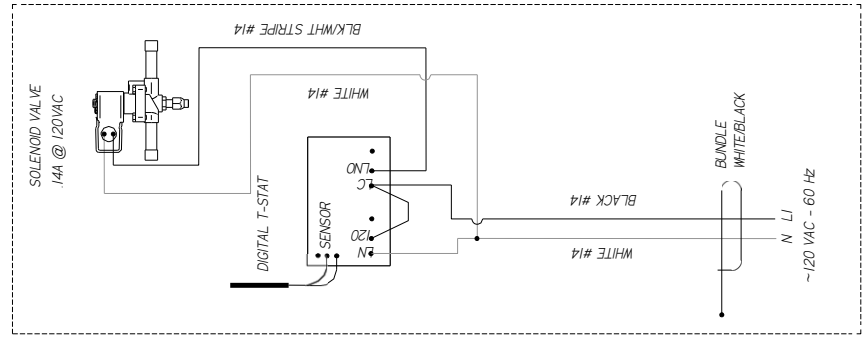

DECK COIL  
SOLENOID VALVE  
1/4A @ 120VAC

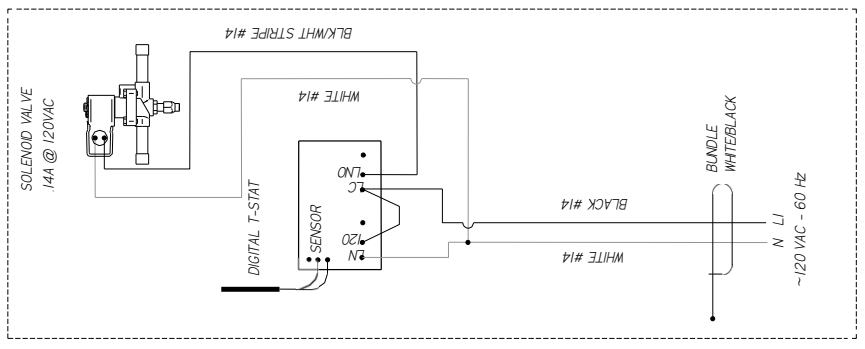

NOTES:  
CASE MUST BE GROUNDED  
WHEN PASSING WIRES THROUGH METAL HOLES A GROMMET MUST BE USED

MATERIAL - N/A  
DATE DRAWN - 2/2/23  
DRAWN BY - GCHG  
CHECKED BY - GCHG  
BOOREY  
TOLERANCES ARE DECIMALS .XX ±0.3, .XXX ±0.10  
ANGLES ± 2

WISSMANN  
DIAGRAMS  
MFV-E-P-4R

3062745 | C

PROJECTION

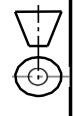

REV	EN	DATE	REVISION DESCRIPTION	REV BY	CHK BY	APPR BY
1		20/06/2022	RELEASED TO PRODUCTION	CB	CB	CB
2		20/06/2022	RELABELLED DIGITAL T-STAT	CB	CB	CB
3		20/06/2022	NEW AIR SWEEP FAN	AL	CB	CB

REVISION HISTORY	DATE	REVISION DESCRIPTION	REV BY	CHK BY	APPR BY
1	20/06/2022	RELEASED TO PRODUCTION	CB	CB	CB
2	20/06/2022	RELABELLED DIGITAL T-STAT	CB	CB	CB
3	20/06/2022	NEW AIR SWEEP FAN	AL	CB	CB

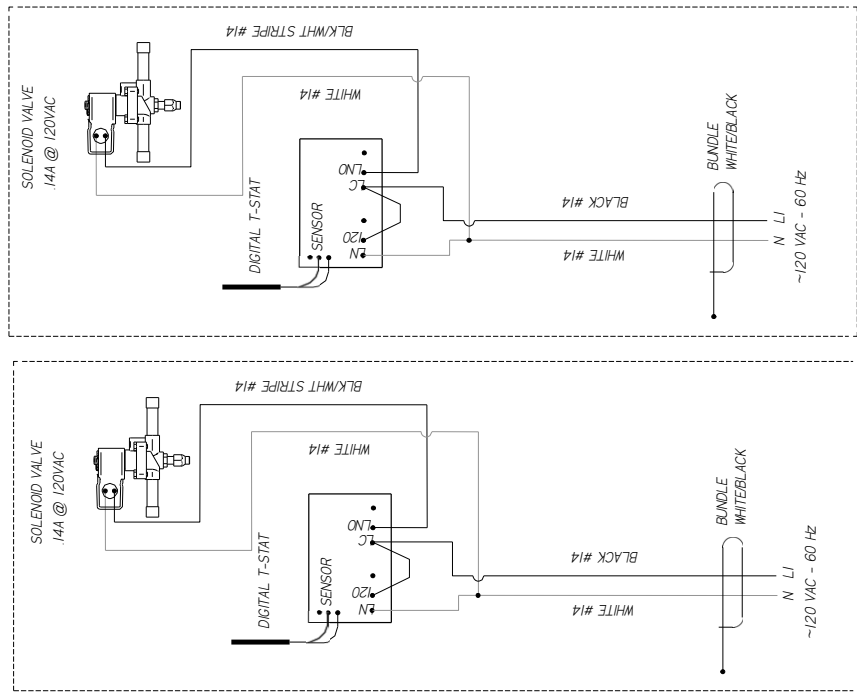
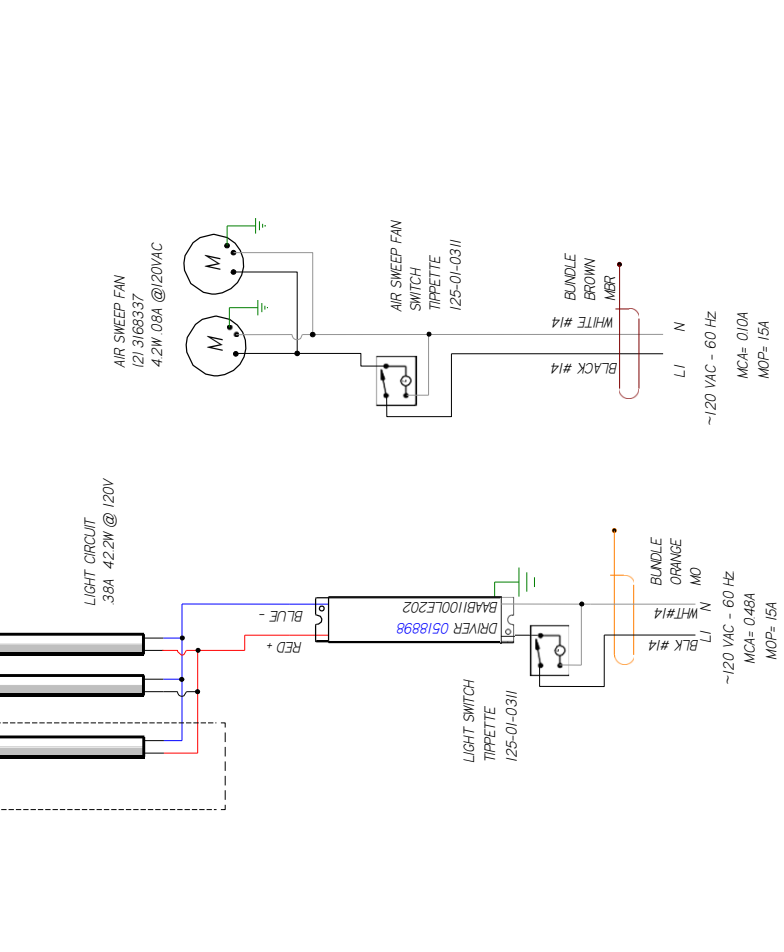
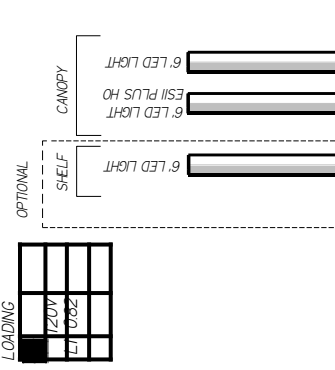
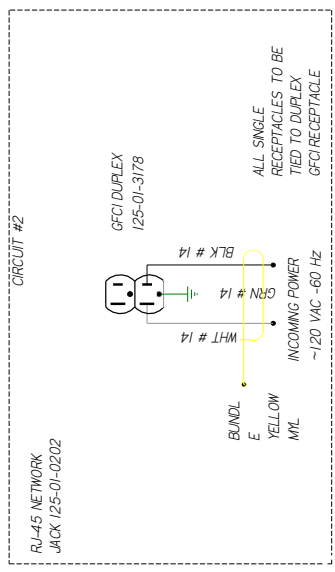

MATERIAL: N/A  
DATE DRAWN: 20/06/2022  
REF: EON-CAP-001269Z  
DRAWN BY: GREG BOOREY  
SHEET OF: 1  
DIMENSIONS OTHERWISE SPECIFIED ARE IN INCHES  
TOLERANCES ARE DECIMALS: XX ± 0.3, XXX ± 0.10  
ANGLES ± 2

**WISSMANN**  
DIAGRAMS  
MFV-E-P-6R  
3062747 | C

NOTES:  
CASE MUST BE GROUNDED  
WHEN PASSING WIRES THROUGH METAL HOLES A GROMMET MUST BE USED



REV	EN	DATE	REVISION DESCRIPTION	REV BY	CHK BY	APPROV
A	EDV	2016/05/11	RELEASED TO PRODUCTION	CB	CB	CB
B	EDV	2020/04/02	RE-LABELLED DIGITAL T-STAT	CB	CB	CB
C	EDV	2023/02/02	NEW AIR SWEEP FAN	AL	CB	CB

CIRCUIT #1  
LOADING

120V			
L1	T0		

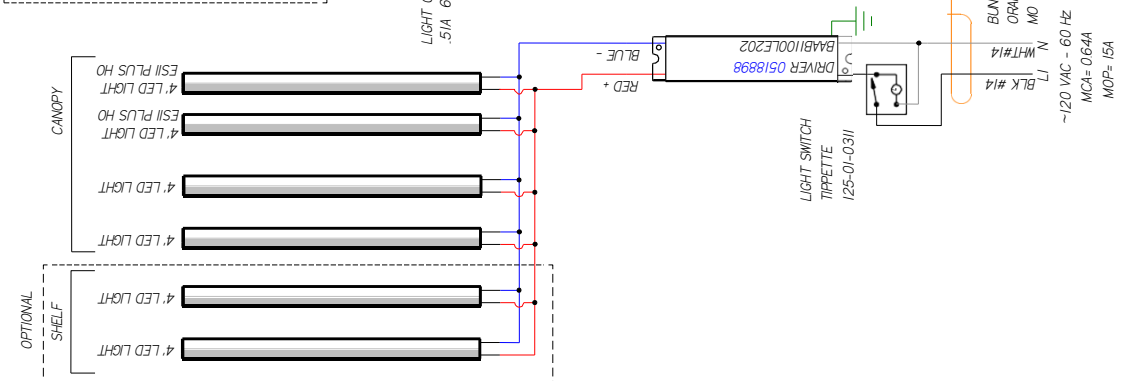
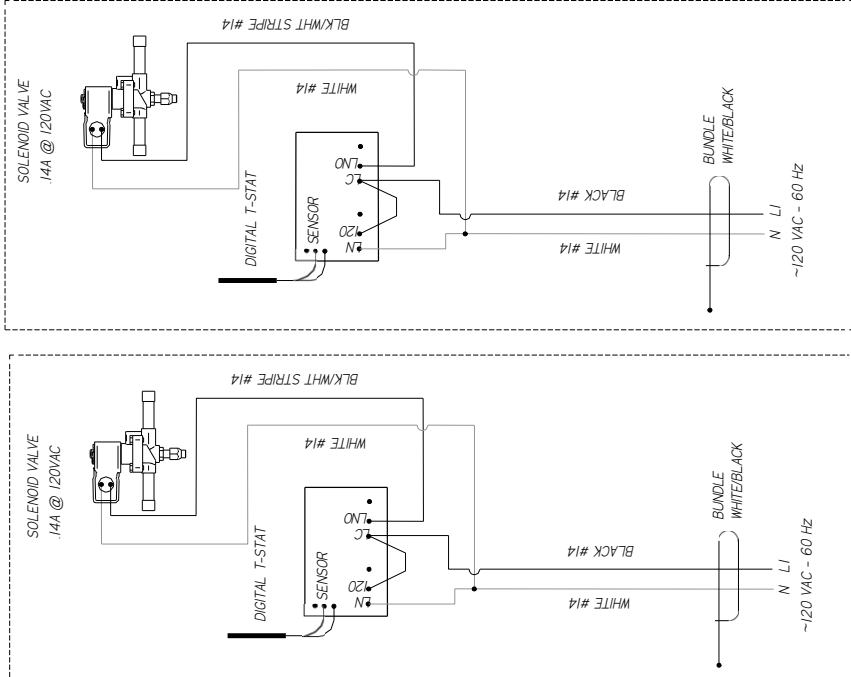
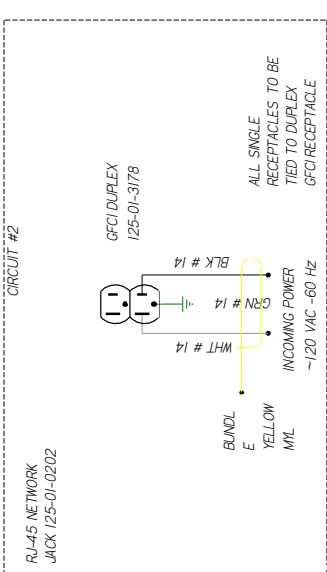

NOTES:  
CASE MUST BE GROUNDED  
WHEN PASSING WIRES THROUGH METAL HOLES A GROMMET MUST BE USED

**WISSMANN**  
DIAGRAMS

MATERIAL: N/A  
DATE DRAWN: 2023/02/02  
REF: EON-CAP-007269Z  
DRAWN BY: GCHG  
CHECKED BY: BOOREY  
SHEET OF: 1  
DIMENSIONS OTHERWISE SPECIFIED ARE IN INCHES  
TOLERANCES ARE:  
DECIMALS: XX ± 0.3, XXX  
+0.10  
ANGLES: ± 2

3062748 | C

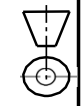

CIRCUIT #1	DNB			
	120V			
	114			

REV	EN	DATE	REVISION DESCRIPTION	REV BY	CHK BY	APPR BY
1	EVN	20170829	RELEASED TO PRODUCTION	CB	CB	CB
2	EVN	20201002	RE-LABELLED DIGITAL T-STAT	CB	CB	CB
3	EVN	20231022	NEW WIRING SCHEMATIC	AL	CB	CB

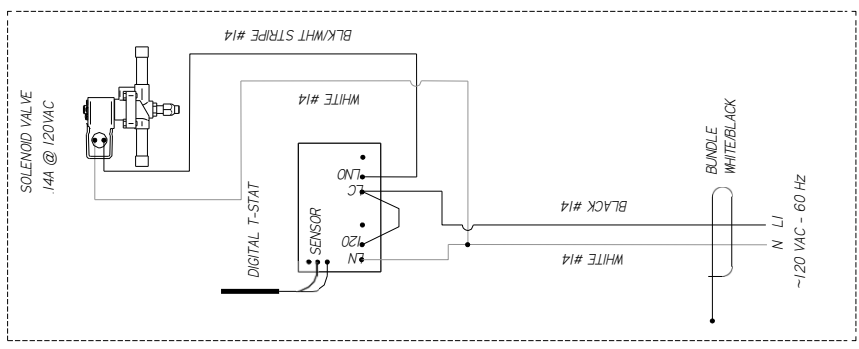
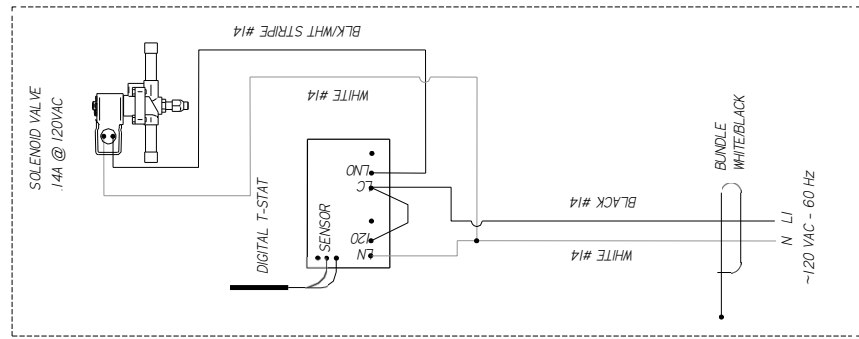
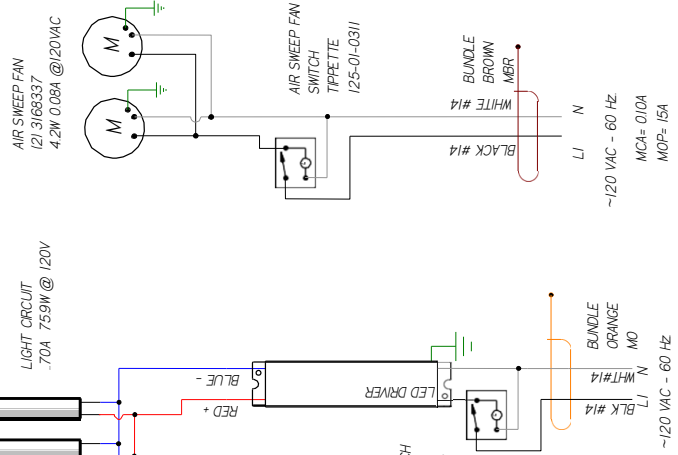
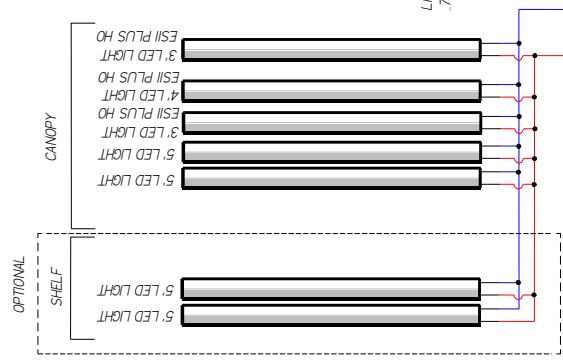
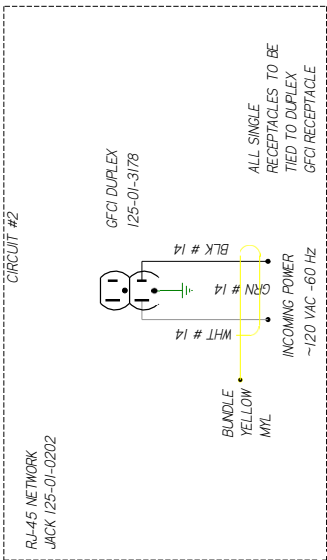

**WISSMANN**  
DIAGRAMS  
MVF-E P-IOR

MATERIAL - NA  
DATE DRAWN - 9-29-17  
DRAWN BY - CRAIG BOOREY  
REVIEWED BY - CRAIG BOOREY  
APPROVED BY - CRAIG BOOREY  
SHEET 1 OF 1  
UNLESS OTHERWISE SPECIFIED DIMENSIONS ARE IN INCHES  
TOLERANCES ARE:  
DECIMALS: XX ± 0.3, XXX ± 0.10  
ANGLES ± 2

PROJECTION

3045986 | C

NOTES:  
CASE MUST BE GROUNDED  
WHEN PASSING WIRES THROUGH METAL HOLES A GROMMET MUST BE USED

REV	EN	DATE	REVISION DESCRIPTION	REV BY	CHK BY	APPROB
A		20180501	RELEASED TO PRODUCTION	CB	CB	CB
B		20200813	ADDED DRIVER FOR ULTRA CANOPY LIGHTS	CB	CB	CB
C		20230202	NEW AIR SWEEP FAN	AL	CB	CB

CIRCUIT #1	120V	1/15
1		
2		
3		
4		

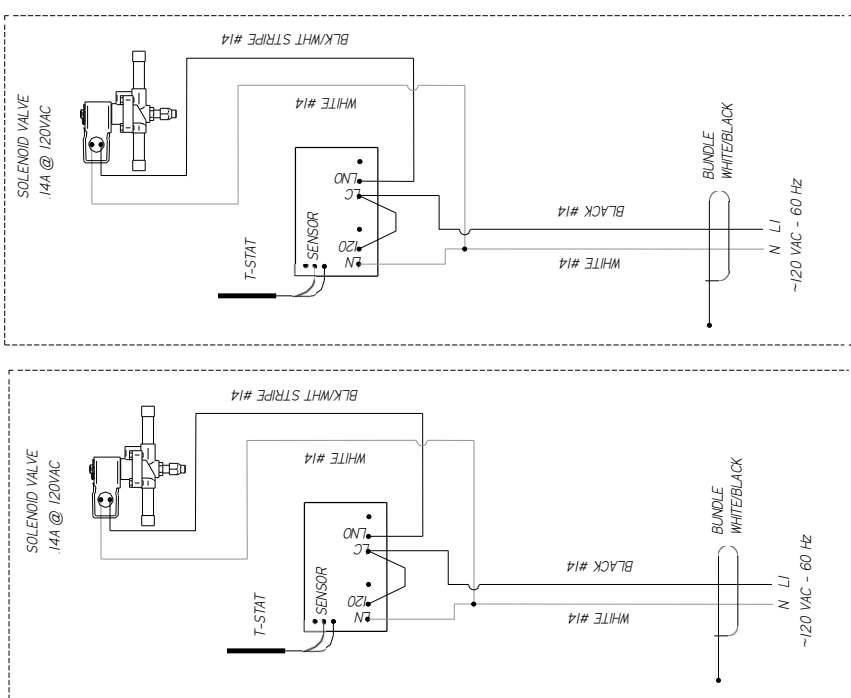
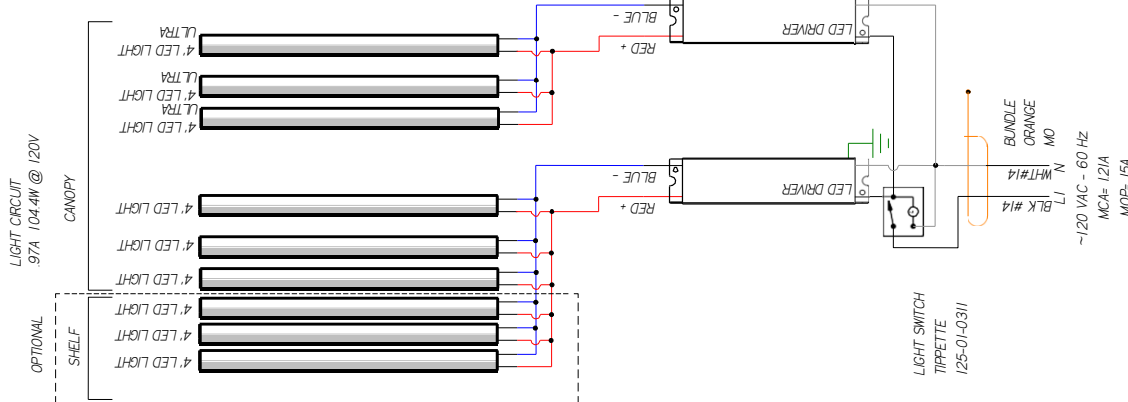
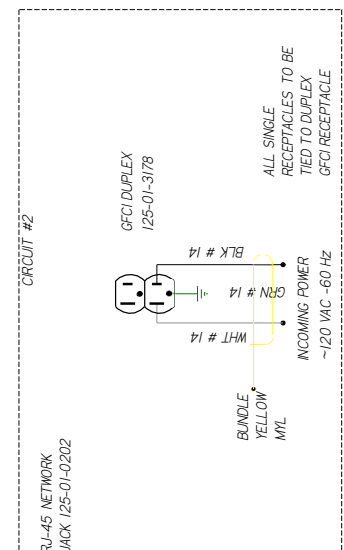

NOTES:  
CASE MUST BE GROUNDED  
WHEN PASSING WIRES THROUGH METAL HOLES A GROMMET MUST BE USED

**WISSMANN**  
DIAGRAMS

MATERIAL: N/A  
DATE DRAWN: 01/01  
ECON-CAP-001269Z

DESIGNED BY: CB  
DRAWN BY: CB  
CHECKED BY: BOOREY

REF: SHEET 01 OF 11  
DIMENSIONS UNLESS OTHERWISE SPECIFIED ARE IN INCHES  
TOLERANCES ARE DECIMALS: XX ±0.3, XXX ±0.10

ANGLES ± 2°

PROJECTION

3062749 | C

CIRCUIT #1  
LOADING

1	2	3	4
120V			
L1	L2	L3	L4

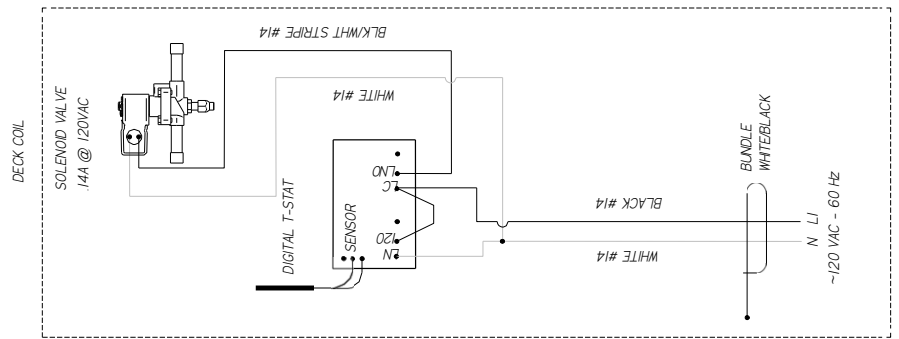
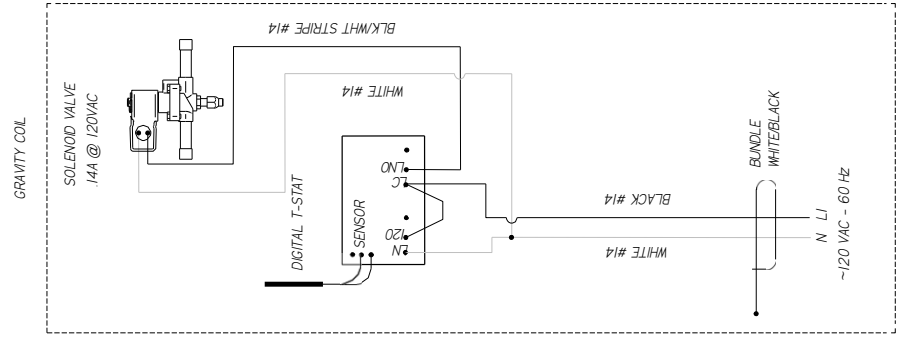
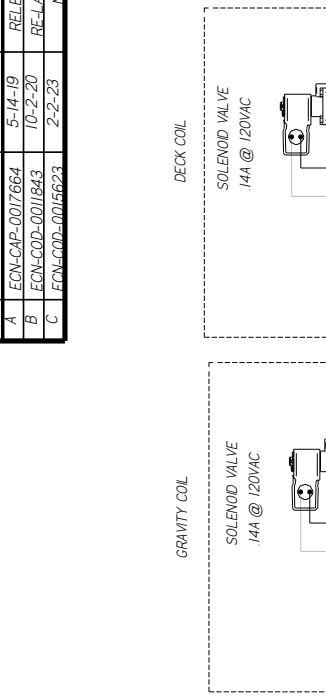
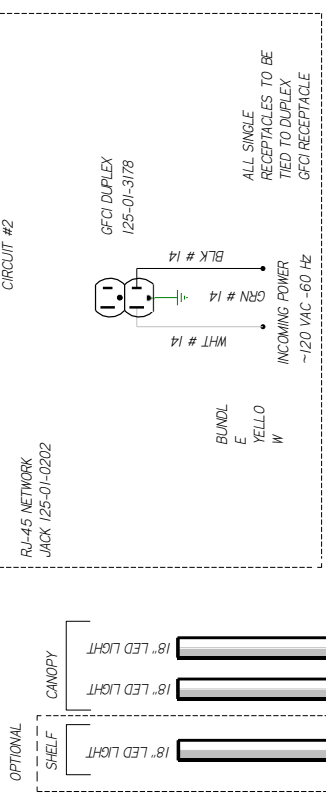

REVISION HISTORY			
REV	ECN	DATE	REVISION DESCRIPTION
A	ECN-CAP-0017664	5-14-19	RELEASED TO PRODUCTION
B	ECN-COD-0011843	10-2-20	RE-LABELLED DIGITAL T-STAT
C	ECN-COD-0016623	2-2-23	NEW AIR SWEEP PN

REVISION HISTORY			
REV	BY	CHKD BY	APPR BY
A	CB	CB	CB
B	CB	CB	CB
C	AL	CB	CB

**HUSSMANN**

DIAGRAM-03-  
MIFV-E P-450-R

FACTORY 14GA WIRE  
 - FACTORY LOGA WIRE  
 - FIELD WIRE

DO NOT SCALE DRAWING  
 SHEET 1 OF 1

UL COLOR CODES / ABBREVIATIONS  
 RED = RD  
 BLACK = BK  
 BLUE = BL  
 YELLOW = YL  
 GRAY = GR

WHITE = WT  
 GREEN = GN  
 BROWN = BRN  
 BN  
 ORANGE = OR  
 OR VIOLET = OV  
 VT

3095452

- NOTES:**
1. PRINTED DOCUMENT REQUIRED SETTING. ALL COLORS BLACK & WHITE
  2. CASE & ANY REMOVABLE PANEL WITH ELECTRICAL PARTS MUST BE GROUNDED.
  3. WHEN PASSING WIRES THROUGH METAL HOLES A GROMMET MUST BE USED

# User Information

## Start Up

See the merchandisers Data Sheet Set for refrigerant settings and defrost requirements. Bring merchandisers down to the operating temperatures listed on the Data Sheet.

 **WARNING**

--LOCK OUT/ TAG OUT--

To avoid serious injury or death from electrical shock, always disconnect the electrical power at the main disconnect when servicing or replacing any electrical component. This includes, but is not limited to, such items as doors, lights, fans, heaters, and thermostats.

## Load Limit

Each Merchandiser has a Load Limit. Shelf life of perishables will shorten if Load Limit is violated.

**AT NO TIME SHOULD THE MERCHANDISER BE STOCKED BEYOND THE LOAD LIMITS INDICATED.**

**DO NOT BLOCK HONEYCOMB OR AIR RETURN GRILLE.**

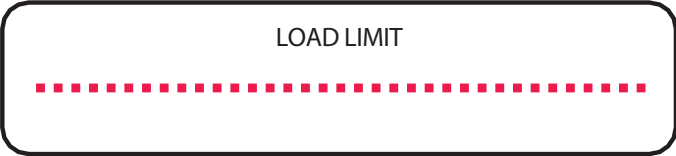

**DO NOT OVERSTOCK MERCHANDISER**

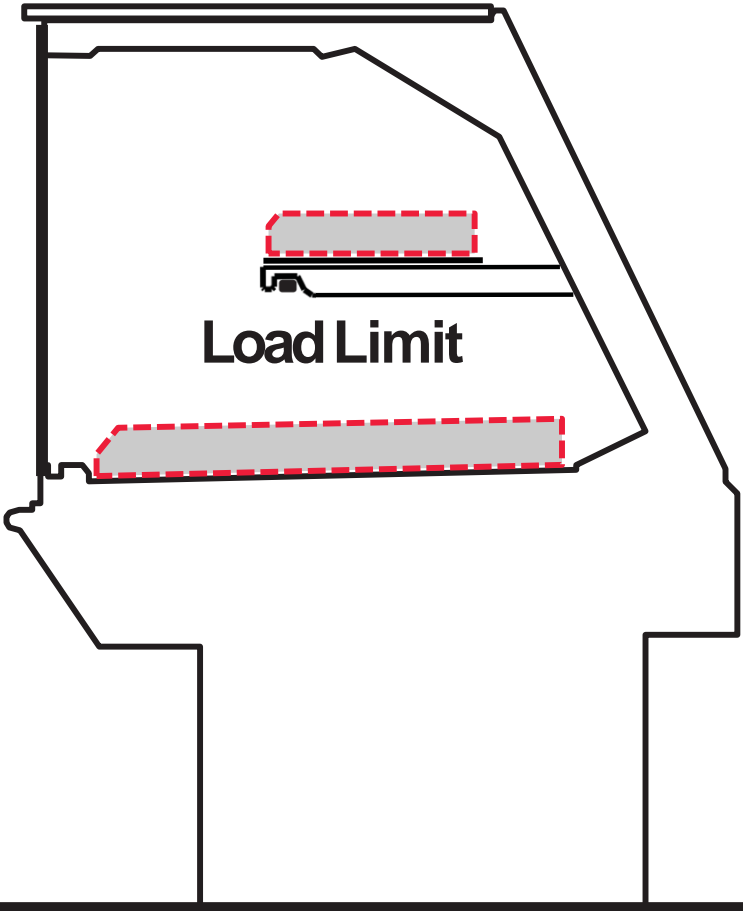

## User Information (cont'd)

### OPERATION SPECIFICATIONS

This case is designed to operate in store conditions of 75F and 55%RH\* or lower. The case is equipped with easy adjustment features for varying store conditions.

#### Baseline Settings

75°F and 55%RH\* ambient store conditions

- Evaporator temperature: 28° F specific refrigerant equivalent (with coils under load)
- Superheat (SH): 3-6°F (as low as 1-2°F SH is acceptable on Deck)
- Discharge air (DA) from gravity coil: 33-36°F typical range
- Discharge air Velocity: 50-75 FPM
- Digital T-Stat (A421) Set Point (SP) Cut in Temperature / Differential (dIF Cutout from SP): Gravity Coil 34°F/1°F and Deck Coil 32°F/1°F
- Defrost: 1/day, 50 minutes
- Air Sweep Fans: On/Off switch (only use if needed)

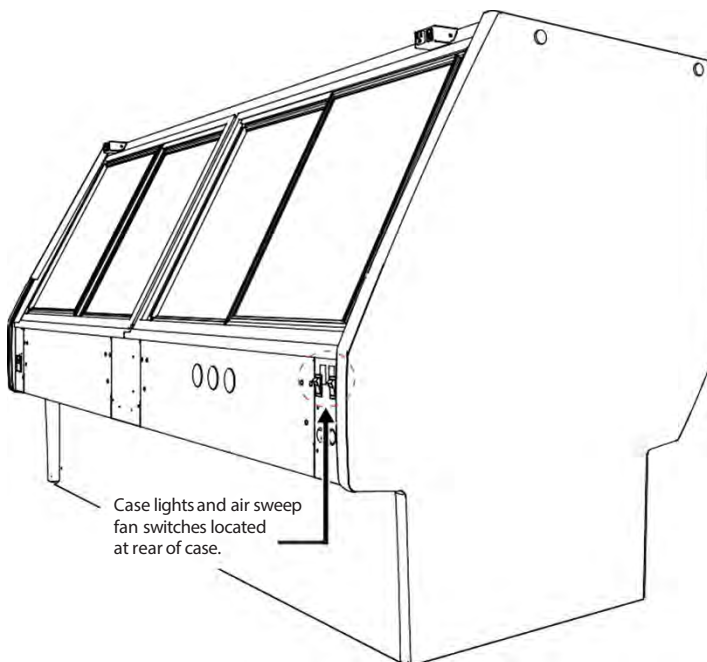

Store conditions, if different from design conditions, may require adjustments to settings as listed in the SETUP TROUBLE SHOOTING section.

Please refer published case specifications on Hussmann website

Refer to A421 Display Symbols, Control Function, Ranges, Units, Values, and Factory Settings Display Symbol for further information

#### Case Switches

The Q3-M/F-V is equipped with 2 functioning switches at the rear right of the case. Switches will be labeled per function; lights and air sweep fans.

#### Air Sweep Fans

The Q3-M/F-V is equipped with several Airsweep Fans based on case length (**see pg 19 for fan config.**) at the front underside of the case. See illustration below.

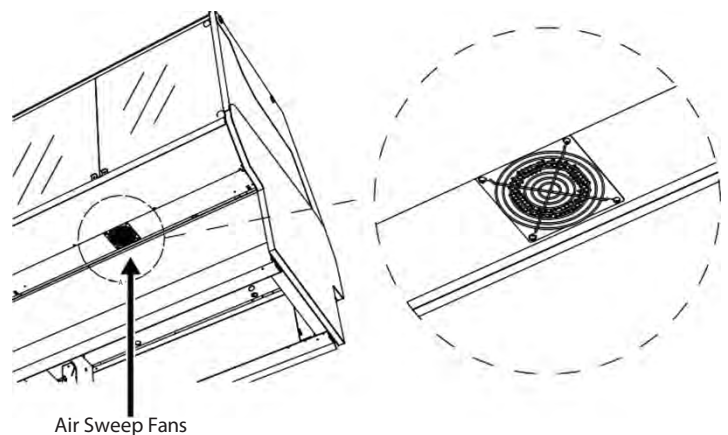

# User Information (cont'd)

## Merchandising Requirements

Use a consistent display strategy in each case. Hussmann recommends the use of flat bottomed aluminum or high density plastic trays as the ideal merchandising display method.

When displaying product on flat trays directly on the deck surface (ideal display method), layer product single or double high keeping product within the load limits (page 27). This promotes even cooling from both the spiral deck coil below and gravity coil above, and allows for less refrigeration power, lower dehydration and increased product life.

Rotate product every several hours. Bottom layer should be rotated to the top and flipped. This ensures even cooling, dehydration and color maintenance.

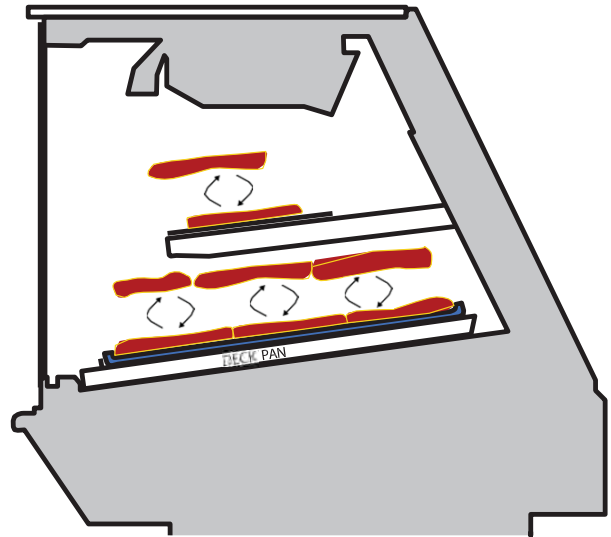
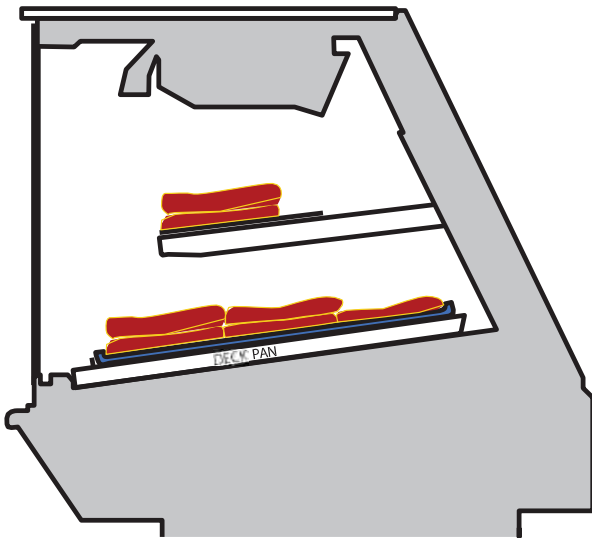

As demonstrated below, each layer of product has a slight increase in internal product temperature the higher it is stacked. It is very important that each layer make direct contact with the layer below it. With conductive cooling, heat will flow from the warmer surface to the cooler surface until both are nearly at the same temperature.

Deck Temperature (DT) / Shelf Temperature (ST)

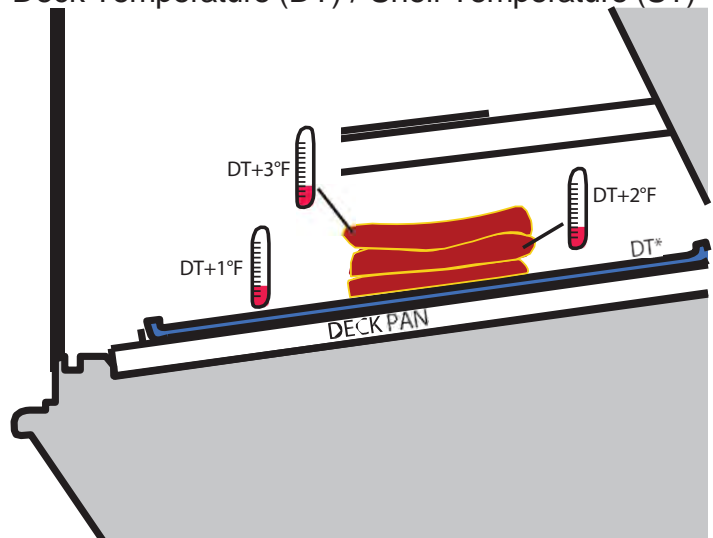

\* DT/ST will vary based on store conditions and case set points.

## User Information (cont'd)

### Merchandising DON'TS

Products can be stacked too high on trays or display ware, the Spiral serpentine coil underneath the deck pans are the main source for cooling for the case. If you are not achieving the internal product temperature your store desires, remove one layer. Monitor product interval temperatures for several hours.

**By no means use Foam, polycarbonate, wood, synthetic solid surface materials or any other product partition which acts as an insulator to display product.** When separating product from direct contact preferably refer to Butcher Paper if desired.

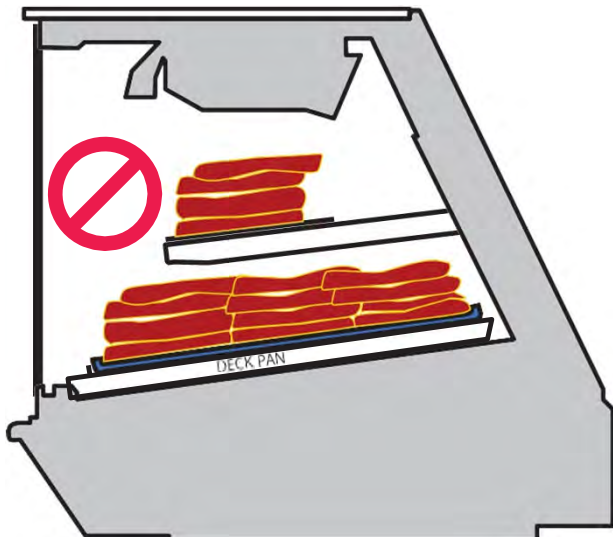

Display ware used inside a Q3-M/F-V **MUST BE FLAT BOTTOMED** to make direct contact with the cooled deck pans, keep in mind that most display ware is designed with ridge along the bottom end or ridges across the surface bottom for structural support. Often times display ware has feet on the bottom of it to prevent direct contact with the display pan. Refrain from using any display ware which prevents direct contact between the display ware bottom and the cooled display pans. Any air space between the Hussmann opticold deck pans, the display ware or the product will adversely affect case performance and cause elevated product temperature and early product loss.

The following Display Wares or display configurations are **NOT RECOMMENDED** and working outside of the Hussmann requirements will adversely affect product and/or case performance.

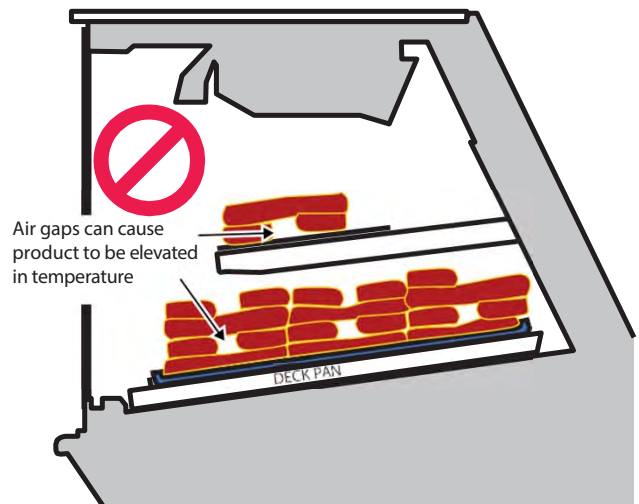
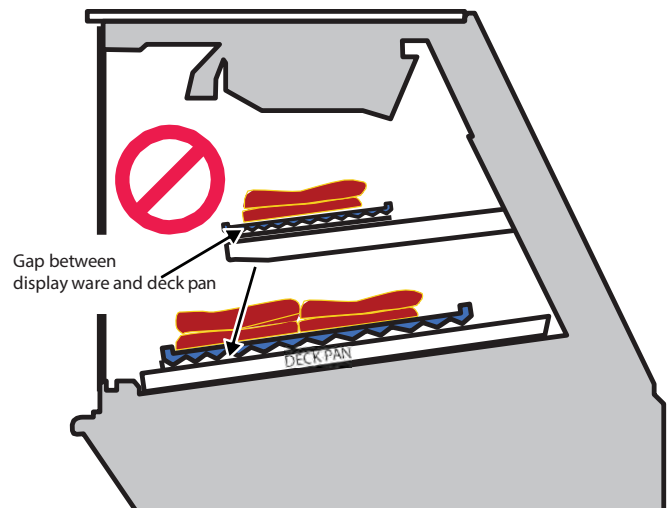
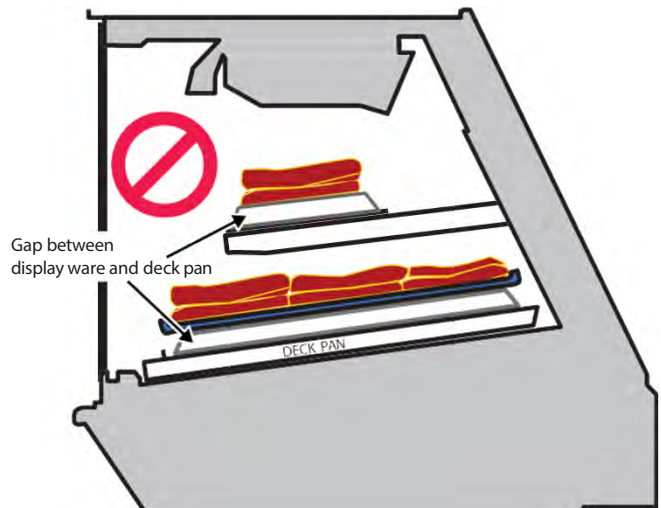

## A421 Setup Codes

Parameter Code	Parameter Description	Range of Usable Values	Factory Default Value
Un	Temperature Units (Advanced Only)	°F or °C	°F
OFF	Relay Off Temperature (Basic, Advanced, and Restricted)	-40 to 212 °F (-40 to 100 °C)	25°F
On	Relay On Temperature (Basic and Advanced)	-40 to 212 °F (-40 to 100 °C)	30°F
ASd	Anti-Short Cycle Delay (Basic and Advanced)	0 to 12 (minutes)	1 (minute)
tSb	Temperature Setback (Advanced only)	-50 to 50 °F (-30 to 30 °C)	0°F
So	Sensor Offset Adjustment (Advanced only)	-5 to 5 °F (-3 to 3 °C)	0°F
HtS	High Temperature Stop (Advanced only)	-40 to 212 °F (-40 to 100 °C)	212°F
LtS	Low Temperature Stop (Advanced only)	-40 to 212 °F (-40 to 100 °C)	-40°F
SF	Sensor Failure Action (Basic and Advanced)	0 = output relay de-energized 1 = output relay energized	1 (output relay energized)
bLL	LCD Backlight Brightness Level Adjustment (Advanced only)	0 to 10; 0 = backlight off 10 = brightest backlight setting	10 (brightest backlight)

1. The default values for general application A421 models are shown. OEM A421 models may have different default values.

# Maintenance

## Case Cleaning Instructions

Long life and satisfactory performance of any equipment are dependent upon the care it receives. Use this guide for proper sanitation and to minimize maintenance costs.

The cleaning processes described below should not require removing of fasteners or other parts of the case - contact maintenance if the need arises.

### Sections

- A. Warnings and Precautions
- B. Do's and Don'ts
- C. Recommended supplies and methods
- D. Daily / Weekly Procedures

### A. Warnings & Precautions



## WARNING

Product may degrade if allowed and may spoil if allowed to sit in a non-refrigerated area.

Store product in a refrigerated area such as a cooler during the cleaning process. Remove only as much product as can be taken to the cooler in a timely manner.

ICE in or on the coil indicates the refrigeration and defrost cycle is not operating properly. Contact an authorized Service Technician to determine the cause of icing and to make proper adjustments as necessary. To maintain product integrity, if not done so already, move all product to a cooler until the merchandiser has returned to normal operating temperatures.

For cleaning coils: **NEVER USE SHARP OBJECTS AROUND COILS.** Use a soft brush or vacuum brush to clean debris from coils.

- Do not puncture Coils!
- Do not bend fins.
- **Contact an authorized service technician** if a coil is punctured, cracked, or otherwise damaged.

## B. Do's and Don'ts

### DO:

- Remove the product and all loose debris to avoid clogging the waste outlet.
- Store product in a refrigerated area such as a cooler during the cleaning process. Remove only as much product as can be taken to the cooler in a timely manner.
- Clean from top to bottom when cleaning the display case to avoid cross contamination.
- Thoroughly clean all surfaces with soap and hot water. Do not use steam or high pressure water hoses to wash the interior. These will destroy the merchandisers' sealing causing leaks and poor performance.
- Avoid direct contact between fan motors and cleaning or rinse water.
- Rinse with hot water, but **DO NOT** flood. Never introduce water faster than the waste outlet can drain.
- Allow merchandiser to completely dry before resuming operation.
- LED lights are magnetized to each shelf and can be removed easily for any shelf cleaning.
- After cleaning has been completed, remember to restore power back to merchandiser.

### DON'T:

- Don't use solvent, oil or acidic based cleaners on any interior surfaces.
- Don't use abrasive cleansers and scouring pads, as these will mar the finish.
- Don't use scouring powders or steel wool as they will scratch stainless steel.
- Never use hydrochloric acid (muriatic acid) on stainless steel.
- Don't use a hose (with flowing water) to clean tub area.
- Don't use steam or high pressure water hoses to wash the interior – these will destroy the sealing causing leaks and poor performance.
- Don't introduce water faster than the waste outlet

## Maintenance Cont'd

can drain it.

- Don't use a hose on lighted shelves or submerge the shelves in water.

### C. Recommended supplies and methods

- Mild cleaning solution
- Sanitizer
- Glass cleaner (see below recommendations)
- Clean towels or paper towels (see below recommendations)
- Soap and hot water
- Non-abrasive cleaning pads

#### Cleaning Cloths:

- Scotch-Brite® High Performance Cloth – manufactured by 3M® and available in most grocery stores under the name Scotch-Brite® Microfiber Cleaning Cloth in a 12" x 14" size. This cloth is washable and may be reused as long as it remains clean.
- Spontex® Microfibre Cleaning Cloth – distributed by Spontex® and available in most grocery stores under the same name in a 15.75" x 12" size. This cloth is washable and may be reused as long as it remains clean.

Cleaning Fluids – for more difficult cleaning jobs, these products are recommended:

- Windex® - standard product only (extra-strength or specialty products may not be suitable)
- Glass-Plus® - standard product only (extra-strength or specialty products may not be suitable)
- Exceed® Multi-Surface & Glass Cleaner – from Kay Chemical Company, Greensboro, NC

#### C-1: GLASS surfaces:

For standard glass, use a mild glass cleaner and a clean paper towel or cloth to wipe the glass. For non-glare glass, refer to the previous "Recommended supplies..." section

#### C-2: STAINLESS STEEL

- Use non abrasive cleaning materials, and always polish with the grain of the steel. Use warm water or add a mild detergent to the water and apply with a cloth. Always wipe dry after wetting.
- **Use non-chlorine containing cleaners such as window cleaners and mild detergents. Do not use cleaners containing salts as this may cause pitting and rusting of the stainless steel finish. Do not use bleach.**
- Clean frequently to avoid build-up of hard, stubborn stains. A stainless steel cleaning solution may be used periodically to minimize scratching and remove stains.
- Rinse and wipe dry immediately after cleaning. Never use hydrochloric acid (muriatic acid) on stainless steel.

#### C-3: MIRRORED surfaces

Use a mild glass cleaner and a clean paper towel or cloth to wipe the surface. NEVER USE ABRASIVE CLEANSERS OR SCOURING PADS.

#### C-4: PAINTED surfaces

Cleaned with a mild detergent without chloride and warm water to protect and maintain their attractive finish. NEVER USE ABRASIVE CLEANSERS OR SCOURING PADS.

### Schedule and procedures

Follow the recommended schedule below for optimal sanitation and case efficiency and to avoid the corrosive action of food fluids on metal parts that are left on for long periods of time. Exterior and interior cleaning can vary on upkeep of the merchandiser through daily use.

# Maintenance Cont'd

## Daily Procedures

Clean from top to bottom to avoid cross contamination.

- 1. Unload the case completely.



Pull product from the rear or front of case. Wrap product, use speed racks to minimize dehydration.

- 2. Clean deck with sanitizer. Dry with paper towel or clean cloth.

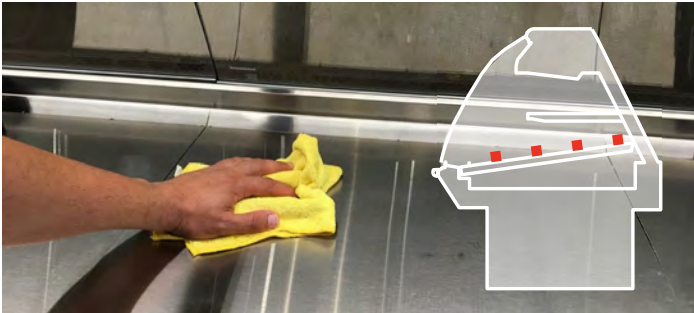

- 3. Wipe and sanitize all areas that food product may have contacted or any surfaces that may have been touched. This will minimize cross contamination.



- 4. Clean and sanitize underside of drip trays.



- 5. Clean and sanitize shelf surfaces.

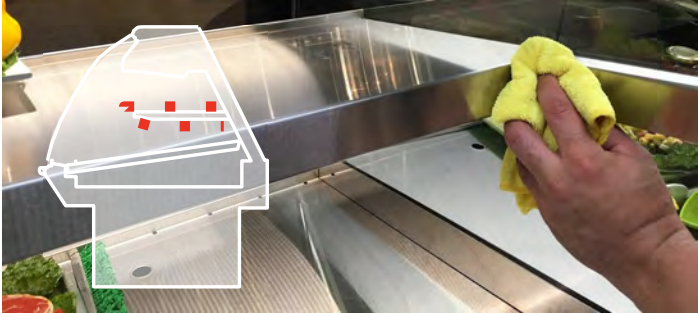

- 6. Clean and sanitize underside of shelves



- 7. Clean glass surfaces (Refer to section C-1). Do not spray cleaning solution directly on glass surface. Instead spray cleaning cloth first to avoid over spray.



# Maintenance Cont'd

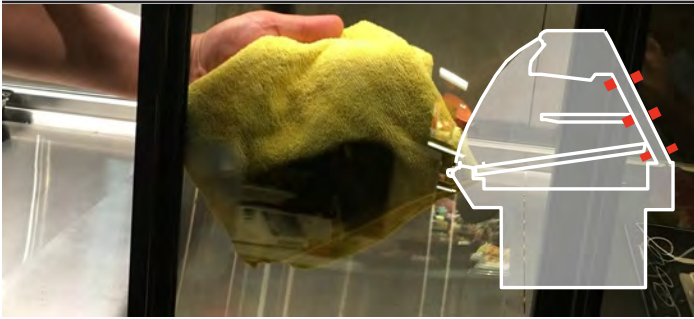

## Weekly Procedures

- 1. In addition to all daily procedures described in the daily procedures...
- 2. Remove deck pans. It is recommended to do so through the front of the case.



- 3. Clean top and bottom. Remove all leaked meat juices



- 4. Inspect and remove food and debris that may have fallen below the deck pans.

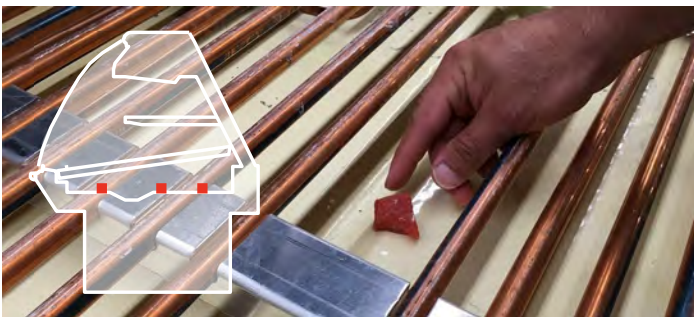

**Do not push debris through drain openings.** Particles may become stuck in P-trap and cause odors.

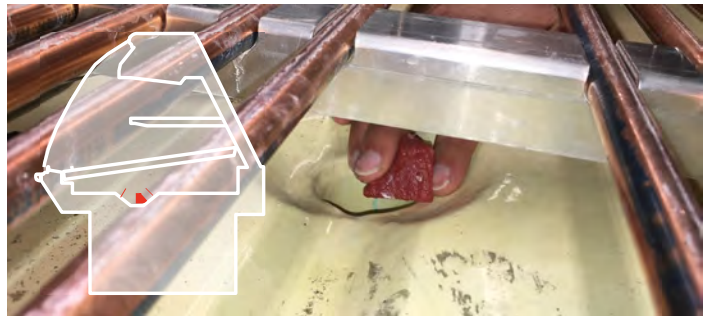

- 5. Sanitize tub surfaces and allow to dry.
- 6. Clean rear door tracks.



Remove doors by lifting and tilting lower edge outward. Clear debris from guide tracks. Wipe and clean as needed.

- 6. Inspect and clear debris from front air sweep.

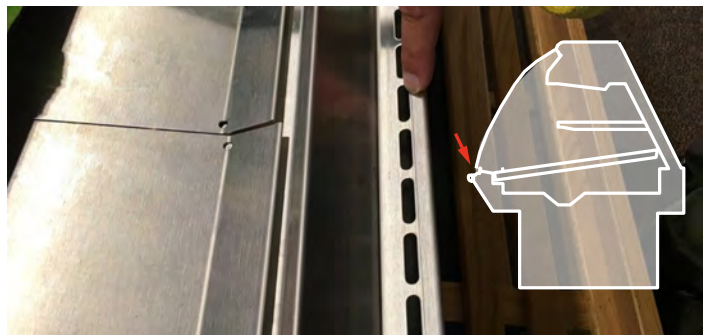

## Maintenance Cont'd

---

### NOTES:

For Hussmann OptiCool™ equipped cases: When reinstalling deck pans, ensure that pans are seated properly and are in contact with the coil system. Optimal performance is compromised if they are not properly reinstalled.



- If ice is present in the coil system, contact maintenance.
- When cleaning scale stands, avoid moving the scale unit itself, recalibrating of the unit may be necessary.
- If floor is power washed, avoid over spraying and contamination under hanging wrapping paper rolls.

## Troubleshooting

Problem	Possible Cause	Possible Solution
<b>Product too cold and/ or freezing</b>	Spiral Deck Coil (SDC) is too cold.	Probe the deck with the product in place. If the deck is less than 29°F increase the SDC thermostatic SP incrementally. Allow approximately 60 minutes or stable temperatures for system to react then recheck temperatures. Verify when SDC T-Stat is active that SDC is operating at desired Temperature/ Pressure (Evap Pressure).
	Gravity Coil (GC) set too cold	Increase thermostatic set point *(SP ) of GC. Your setting will depend on store conditions and desired product temperature. The thermostatic SP is properly set when the product is ideally 33-38°F. Should ice be forming on the GC, verify Evaporator Pressure, GC Discharge Air (DA) is ranging between 33-36°F
	Excessive Icing	Ensure excessive icing condition's don't exist on SDC or that any exist on the GC
	Evaporator Suction Temperature	Ensure case evaporator / suction temperature is above 28°F.
	Superheat Set Too Low	Check superheat and adjust as necessary. See Case Specification
	T-Stat Sensor And TXV Bulbs Not Firmly Secured	<p>Ensure that all T-Stat sensor and TXV bulbs are firmly secured to the pipes in the locations shown in figure (C). The bulbs should be at the 3 or 9 o'clock position on the pipe. Take care to insure SDC T-Stat sensor is below the surface of the Spiral Deck Tube (at mid tube from outer/inner of spiral) to insure no interference with Deck Plate. Band strap should be thin gauge copper. GC T-Stat sensor tip should be located approximately 1" below the bottom fin surface, at approximately coil center (front-back) and between 18"-24" from the end of the case wall.</p> <p>Ensure that the case is piped per the piping diagram (C) [Note: some components may be optional].</p>
<b>Product dehydrating prematurely</b>	GC set too cold	<p>Increase thermostatic SP of GC. Your setting will depend on store conditions and desired product temperature.</p> <p>The thermostatic SP is properly set when the DA from the GC is ranging between 33-37°F, depending upon Meat Department ambient conditions. Product should be turned and rotated about every 4 hours. Product should be covered at night with a clean, damp cloth such as cheese cloth if left in the display case overnight</p>
<b>Product too warm</b>	Improper Case Piping	Verify case is properly piped per the Piping Diagram. Refer to Pipe Diagram
	Improper Suction Pressure Setting	Verify case suction pressure is set to a 28°F temperature equivalent when all Solenoid VLV are active/open
	Improper Superheat Setting	Verify superheat. Adjust TX valves accordingly. Deck/Spiral coil may be set as low as 1-2° SH. Gravity coil may be set as low as 3° SH. (NOTE, when adjusting TXV superheat, first adjust the corresponding T-Stat below equivalent suction temperature. This will ensure that the T-Stat does not close during the adjustment period. Be sure to return T-Stat to SP.

## Troubleshooting cont.

Problem	Possible Cause	Possible Solution
<b>Product too warm</b>	Improper EPR Set Point	If SDC inlet temperature is above 28°F reduce the EPR set point
	Improper Thermostat Bulb Location	Ensure that the thermostat bulb for the gravity coil (A) is not contacting any coil parts and is located in the discharge air stream
	Improper TXV Bulb Location	Ensure that the TX valve bulbs are located as per the piping diagram. Refer to Pipe Diagram
	Improper Deck Plates (and Pans) Sitting	Ensure that the deck plates (and pans) are seated and making good contact with the SDC and each other
	Gravity Coil Air Flow Obstruction	Ensure that gravity coil is fully cleared all the time
	Defrost Failure To Clear All SDC Ice Buildup	The SDC will eventually pack with ice and refrigeration performance will be severely degraded. Confirm Evaporator Temperature is 28°F, SDC T-Stat SP to specification, and SDC termination temperature reaching at least 42°F. Increase the defrost time in 5 minute increments if this condition is observed, and termination temperature not achieved.
	Improperly sized refrigerant lines	Ensure that refrigerant lines are properly sized per the installation manual. Inspect liquid line for kinks, pinched or excessive u-bends
	Solid Column Of Liquid Refrigerant NOT reaching the TXV	Inspect liquid line for kinks, pinched or excessive u- bends.
	Liquid Refrigerant case inlet Temperature is excessive	Ensure that the liquid refrigerant entering temperature is not excessive. Liquid greater than 110°F at 6" ahead of the TXV may be an indication of equipment problems
	Product Introduction Temperature Too High	Correct product introduction temperature should be 34°F.-36°F.
	Product Is Stacked Too High	Reduce display height of product. Less than 6" is recommended
	Product is displayed in containers that impede the conduction cooling from the SDC	Use containers with full length, flat bottoms. Refer to MERCHANDIZING RECOMMENDATIONS (page 29) section for further information.
	Incorrect replacement lighting is adding too much heat	Use only Hussmann genuine replacement parts or equivalent.
<b>Case temperature is too warm.</b>	Ambient conditions may be affecting the case operation.	Check case position in store. Is the case located near an open door, window, electric fan or air conditioning vent that may cause air currents? Case must be located minimum 15 Ft away from doors or windows. Cases are designed to operate at or below 75°F Dry bulb and 55% relative humidity.
	Discharge air temp is out of spec.	Check suction pressure and insure that it meets factory specifications.
	Case is in defrost.	Check defrost settings. See Technical Specifications section.
	Product load may be over its limits blocking airflow.	Redistribute product so it does not exceed load level.

## Troubleshooting cont.

<b>Problem</b>	<b>Possible Cause</b>	<b>Possible Solution</b>
<b>Case temperature is too cold.</b>	The t-stat temp is set too low.	Check settings. See Technical Specifications section.
	Ambient conditions may be affecting the case operation.	Check case position in store. Is the case located near an open door, window, electric fan or air conditioning vent that may cause air currents? Case must be located minimum 15 Ft away from doors or windows. Cases are designed to operate at or below 75°F Dry bulb and 55% relative humidity.
<b>Condensation on glass.</b>	Ambient conditions may be affecting the case operation.	Check case position in store. Is the case located near an open door, window, electric fan or air conditioning vent that may cause air currents? Case must be located minimum 15 Ft away from doors or windows. Cases are designed to operate at or below 75°F Dry bulb and 55% relative humidity.
	There are glass gaps on the side of the case.	See glass adjustment section.
	Glass is not completely shut.	Close glass correctly.
	Ambient Conditions	Turn on Air Sweep Fans located at the right rear of merchandiser.
<b>Water has pooled under case.</b>	Case drain is clogged.	Clear drain.
	PVC drains under case may have a leak.	Repair as needed.
	Case tub has unsealed opening.	Seal as needed.
	If the case is in a line-up, case to case joint is missing or unsealed.	Install case to case joint and seal as needed.
	Evaporator pan is overflowing (if applicable).	Check electrical connection to evaporator pan. Check float assembly, it should move freely up and down the support stem. Clear any debris.
<b>Case is not draining properly.</b>	Case is not level.	Level the case.
	Drain screen is plugged.	Clean drain screen and remove any debris.
	Drain or P-trap is clogged.	Clear any debris.
<b>Frost or ice on evaporator coil.</b>	Defrost clock is not functioning.	Case should be serviced by a qualified service technician.
<b>Lights do not come on.</b>	LED Driver /light wiring.	Check electrical connections. See Electrical Section and check wiring diagram.
	LED Driver needs to be replaced.	Case should be serviced by a qualified service technician. See Electrical Section.
	LED Light needs to be replaced.	Case should be serviced by a qualified service technician.
	Light Switch needs to be replaced.	Case should be serviced by a qualified service technician.



# HUSSMANN<sup>®</sup>

To obtain warranty information  
or other support, contact your  
Hussmann representative.  
Please include the model and  
serial number of the product.

Hussmann Warranty / Technical Assistance  
(800) 592-2060

---

### Service Record

Last service date:    By:

_____	_____
_____	_____
_____	_____
_____	_____
_____	_____
_____	_____
_____	_____

---

## **HUSSMANN®/Chino**

Additional copies of this publication may be obtained by contacting:

Hussmann® Chino  
13770 Ramona Avenue • Chino, California 91710  
(909) 590-4910  
(800) 922-1919

The <i>MODEL NAME</i> and <i>SERIAL NUMBER</i> is required in order to provide you with the correct parts and information for your particular unit. They can be found on a small metal plate on the unit. Please note them below for future reference.
<b>MODEL:</b>
<b>SERIAL NUMBER:</b>