

HUSSMANN[®]/CHINO
Q3-SS
DELI SELF SERVICE CASE

Installation
& Operation
Manual
REV. 1123

HUSSMANN[®]

Q3-SS DELI SELF SERVICE CASE



Table of Contents

Table of Contents 2

General Instructions..... 3

Cut and Plan Views 4

Installation..... 6

Q-Series Case Joining Guide 7

Plumbing 13

Refrigeration 13

Spec Sheets 14

Dixell Controller Operations..... 16

Dixell Controller Settings..... 17

Danfoss Controller Operations 19

Danfoss Controller Settings 20

Electrical..... 24

Electrical Wiring Diagrams 25

Wiring Diagrams 26

Finishing Touches 53

User Information..... 54

Maintenance..... 55

Appendices 56

General Instructions

This Booklet Contains Information on:

Q3-SS refrigerated, service deli merchandiser.

Shipping Damage

All equipment should be thoroughly examined for shipping damage before and during unloading.

This equipment has been carefully inspected at our factory and the carrier has assumed responsibility for safe arrival. If damaged, either apparent or concealed, claim must be made to the carrier.

Apparent Loss or Damage

If there is an *obvious loss or damage*, it must be noted on the freight bill or express receipt and signed by the carrier's agent; otherwise, carrier may refuse claim. The carrier will supply necessary claim forms.

Concealed Loss or Damage

When loss or damage *is not apparent until after equipment is uncrated*, a claim for concealed damage is made. Make request in writing to carrier for inspection within 15 days, and retain all packaging. The carrier will supply inspection report and required claim forms.

Shortages

Check your shipment for any possible shortages of material. If a shortage should exist and is found to be the responsibility of Hussmann Chino, *notify Hussmann Chino*. If such a shortage involves the carrier, *notify the carrier immediately*, and request an inspection. Hussmann Chino will acknowledge shortages within ten days from receipt of equipment.

Hussmann Chino Product Control

The serial number and shipping date of all equipment has been recorded in Hussmann's files for warranty and replacement part purposes. All correspondence pertaining to warranty or parts ordering must include the serial number of each piece of equipment involved, in order to provide the customer with the correct parts.

Keep this booklet with the case at all times for future reference.

HUSSMANN®/CHINO

A publication of HUSSMANN® Chino

13770 Ramona Avenue • Chino, California 91710

(909) 628-8942 FAX

(909) 590-4910

(800) 395-9229



**ATTENTION
INSTALLER**

This equipment is to be installed to comply with the applicable NEC, Federal, State, and Local Plumbing and Construction Code having jurisdiction.

Cut and Plan Views

Q3-SS Series 45° I/S

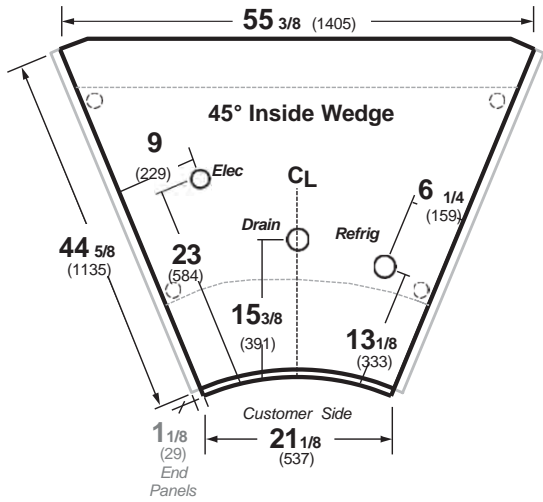

Q3-SS Series 45° O/S

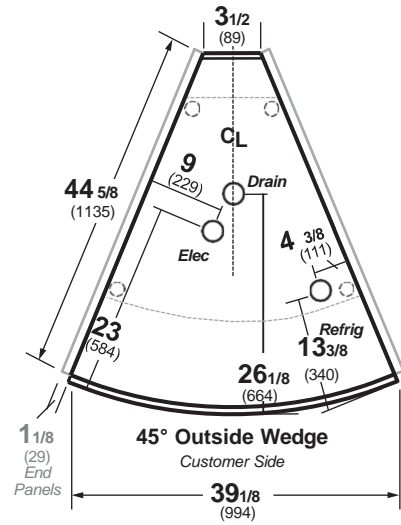

Q3-SS Series 90° O/S

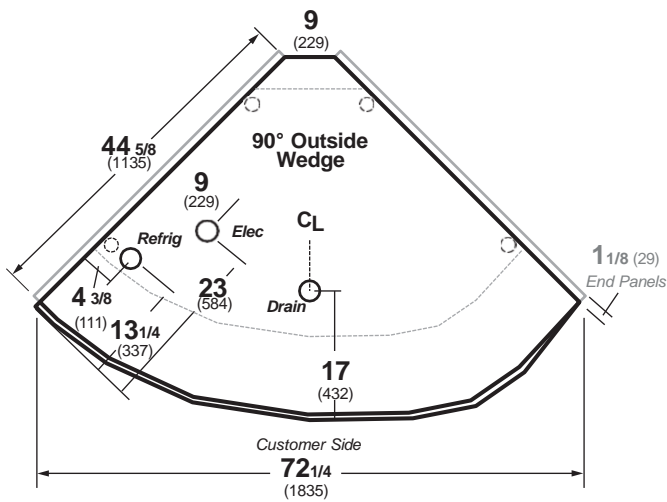

Q3-SS Series 22.5° I/S

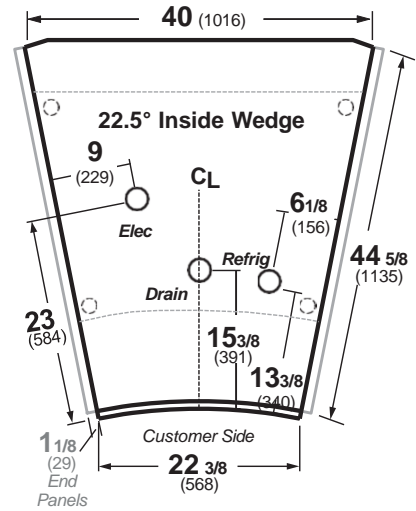

Q3-SS Series 22.5° O/S

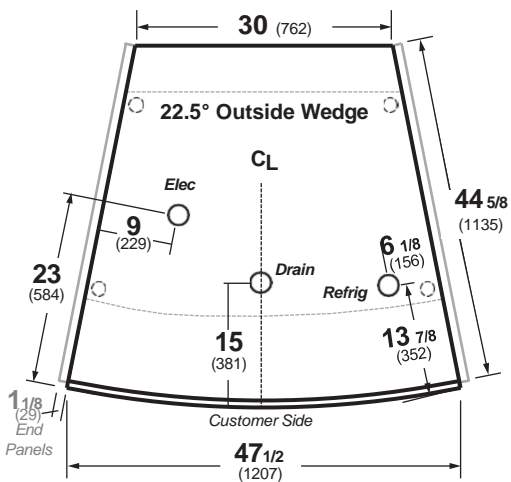

Installation

Location

The refrigerated merchandisers have been designed for use only in air conditioned stores where temperature and humidity are maintained at or below 75°F and 55% relative humidity. **DO NOT** allow air conditioning, electric fans, ovens, open doors or windows (etc.) to create air currents around the merchandiser, as this will impair its correct operation.

Product temperature should always be maintained at a constant and proper temperature. This means that from the time the product is received, through storage, preparation and display, the temperature of the product must be controlled to maximize life of the product.

Uncrating the Stand

Place the fixture as close to its permanent position as possible. Keep in place, attached case until ready to set/bolt to adjoining case.

Tighten Glass Screws

Tighten screws along clamshell located on the underside of glass before placing unit into operation.

Exterior Loading

These models have **not** been structurally designed to support excessive external loading. **Do not walk on their tops;** This could cause serious personal injury and damage to the fixture.

Setting and Joining

The sectional construction of these models enable them to be joined in line to give the effect of one continuous display. An Alignment pin kit is supplied with every case and must be used in alignment.

Leveling

IMPORTANT! IT IS IMPERATIVE THAT CASES BE LEVELED FROM FRONT TO BACK AND SIDE TO SIDE PRIOR TO JOINING. A LEVEL CASE IS NECESSARY TO INSURE PROPER OPERATION, WATER DRAINAGE, GLASS ALIGNMENT, AND OPERATION OF THE HINGES SUPPORTING THE GLASS. LEVELING THE CASE CORRECTLY WILL SOLVE ALL HINGE OPERATION AND GLASS ALIGNMENT PROBLEMS.

NOTE: A. To avoid removing concrete flooring, begin lineup leveling from the highest point of the store floor.

B. When wedges are involved in a lineup, set them first. All cases were leveled and joined prior to shipment to insure the closest possible fit when cases are joined in the field. When joining, use a carpenters level and adjust legs accordingly. The legs on the Q3-SS are adjustable and do not require shims. Simply screw the leg up or down to adjust height.

- Using case blueprints, measure off and mark on the floor the exact dimensions of where the cases will sit. Snap chalk line for front and back positions of base rail or pedestal. Mark the location of each joint front and back. Find the highest point throughout the lineup. **FLOORS ARE NORMALLY NOT LEVEL! Determine the highest point of the floor; cases will be set off this point.** All cases in the entire lineup must be brought up to the highest level of the case sitting at the highest point in the lineup. This may be done a few different ways.
 - Walk the floor looking for any mounds or dips.
 - Use a string level.
 - Use a transit.
 If a wedge is used in the middle of a lineup, the wedge must be set on the highest point on the floor **FIRST**, with the rest of the lineup being leveled from it. The Q3-SS case has adjustable legs to allow for leveling.
- Set first case over the highest part of the floor and adjust legs so that case is level. Remove side and back leg braces after case is set and joined.
- Set second case within one foot (1') of the first case, and remove leg skids. Keep the supports along the length of the case and far end of case. Level case to the first using the instructions in step one.
- Apply masking tape 1/8" in from end of case on inside and outside rear mullion and body work on both cases to be joined.
- Apply liberal bead of case joint sealant (butyl) to first case. Sealant area is shown using a dotted line in illustration in Step 8. Apply heavy amount to cover entire shaded area.

DO NOT USE PERMAGUM!



**ATTENTION
INSTALLER**

This equipment is to be installed to comply with the applicable NEC, Federal, State, and Local Plumbing and Construction Code having jurisdiction.

- Slide second case up to first case snugly. Then level second case to the first case so glass front, bumper and top are flush.



CAUTION

Do not use bolts to pull cases together.

- To compress butyl at joint, use two Jurgenson wood clamps. Make sure case is level from front to back and side to side on inside bulkheads at joint.

Installation (Cont'd)

8. Attach sections together via the bolts pictured in the illustration below.
9. Apply bead of butyl to top of bulk heads and slip on stainless steel bulkhead cap. Also apply silicone to seam between joints.
10. Use finger to smooth silicone as thin as possible at masking tape on inside and outside of rear mullion (apply additional silicone if necessary). Remove tape applied on line #4.
11. Remove front, back and end shipping braces.

Q3-SS Refrigerated Wedges and Standard Cases

Line up taper pins and line-up plates with holes on adjoining case. Bolting is located at the rear of the case, behind the air discharge wall, and behind the front body panel. The cases are bolted together in front by means of a bracket located behind the front panel. Remove the front panel by unscrewing these bottom screws.

Q-Series Case Joining Guide

To adjust the leg height please follow these steps

Before you start any adjustments make sure the cases are level, Front to Back and side to side

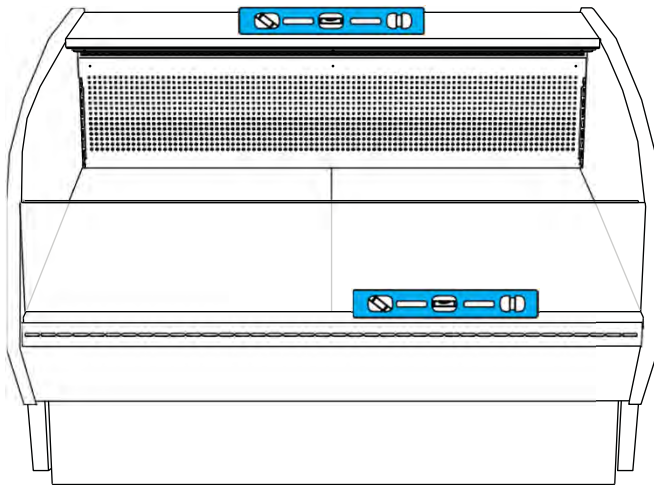

Leg adjustment

To level the cases remove the front and rear close-offs, You can adjust the Height by turning the base leg adjusters

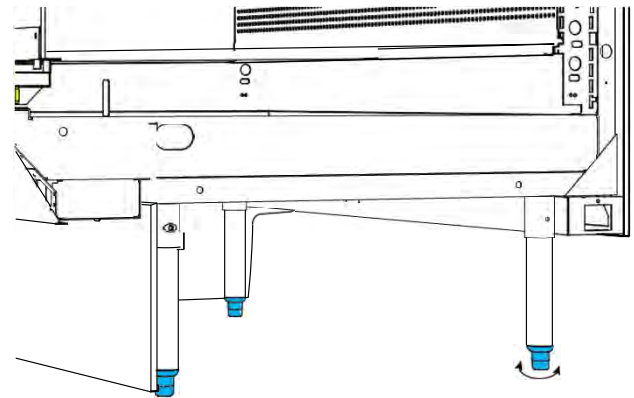

When you turn the leg adjuster clock-wise the case will go up.

When you turn the leg adjuster counter clock-wise the case will go down.

IMPORTANT: Attempting to compensate for poor installation practices by manipulating the canopy hardware will result in unsatisfactory workmanship and possibly cause hardware failure and/or injury.

Installation (Cont'd)

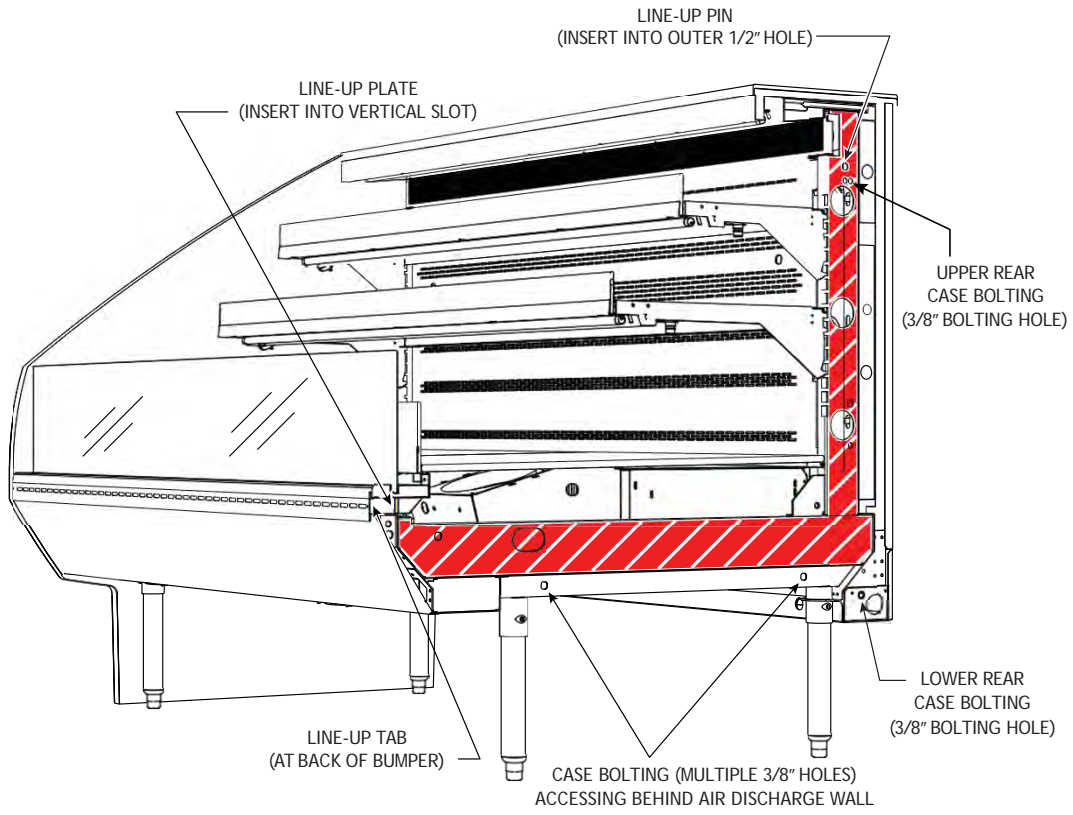

Installation (Cont'd)

Body Panel Removal

To remove the lower body panels follow the demonstration shown below.

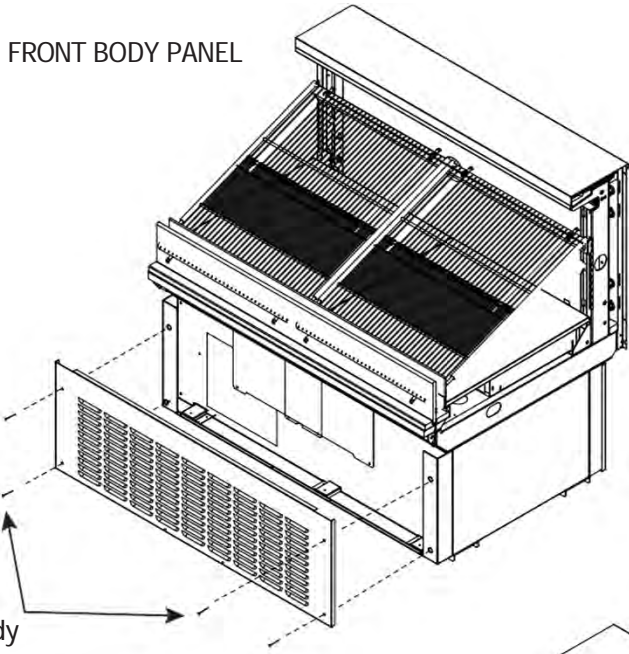

Unfasten screws to remove front Lower Body Panels.

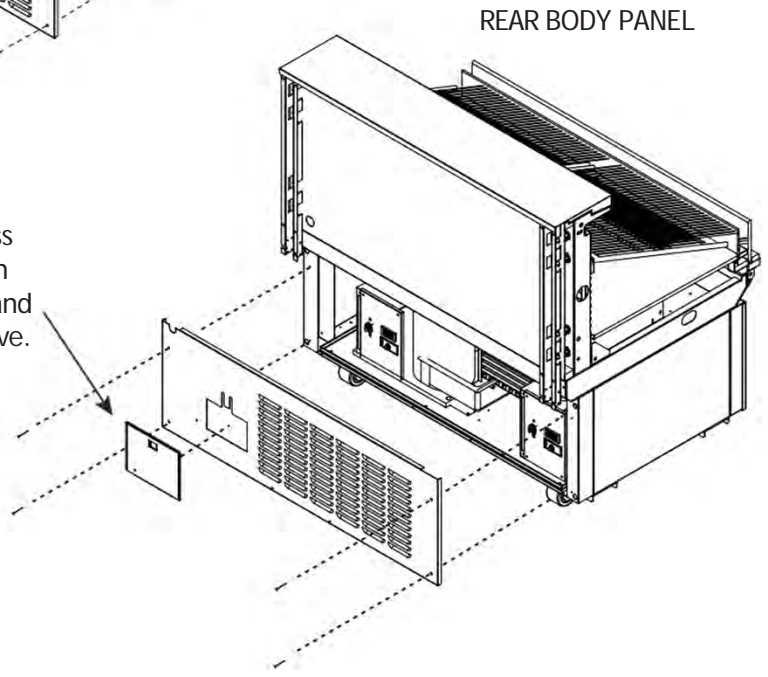

Case Controller access cover plate located on rear Body Panel. Lift and pull outward to remove.

Installation (Cont'd)

Bumper Installation Instructions



Step 1: Make sure the aluminum channel and end caps are installed.



Step 2: Use silicone lubricant to help the bumper slide into the channel.



Step 3: Starting on one end: while inserting the bumper, push it up against the end cap to prevent the bumper from shrinking after installation (when it gets cold).



Step 4: As you insert the bumper into the channel with one hand, pull the bumper toward you with the other to open the inside lips. Slowly apply pressure by rolling the bumper into the track. Boston Series 2000

Installation (Cont'd)

NOTE: Flexible top: Over cut vinyl 1/8" for every 4' section for the flexible top to ensure a proper fit.

NOTE: Rigid Top: Do not over cut.



1. Attach the base and end/corner cap to the desired surface by inserting #8 pan head screws through the pre-slotted holes in both the end cap and the base. Insert screws through the two holes of end cap and tighten.



- 2a. **Flexible Top:** Butt end of the vinyl top against end/corner cap. While applying pressure, bend back vinyl top so that vinyl legs are positioned within the base grooves. Roll vinyl top over full length of base, then tap with rubber mallet to ensure vinyl is securely locked into the base.

- 2b. **Rigid Top:** Snap the Rigid Top over the Rigid Base.



3. If necessary wipe clean with any household cleaning product.

Helpful Hints:

- For best results, before cutting, install a scrap piece of base into vinyl top to achieve a clean cut.
- Set the uncoiled flexible vinyl at room temperature 24 hours prior to installation.
- Lubricate the inside of the vinyl with soapy water or silicone before installing.
- Over cut the flexible vinyl and compression fit. Adding the additional materials will compensate for stretching which occurs during installation.

Boston 2000 Eco Series



1. Attach the base and end/corner cap to the desired surface by inserting #8 pan head screws through the pre-slotted holes in both the end cap and the base. Insert screws through the two holes of end cap and tighten.



- 2a. **Flexible Top:** Butt end of the vinyl top against end/corner cap. While applying pressure, bend back vinyl top so that vinyl legs are positioned within the base grooves. Roll vinyl top over full length of base, then tap with rubber mallet to ensure vinyl is securely locked into the base.

- 2b. **Rigid Top:** Snap the Rigid Top over the Rigid Base.



3. If necessary wipe clean with any household cleaning product.

Helpful Hints:

- For best results, before cutting, install a scrap piece of base into vinyl top to achieve a clean cut.
- Set the uncoiled flexible vinyl at room temperature 24 hours prior to installation.
- Lubricate the inside of the vinyl with soapy water or silicone before installing.
- Over cut the flexible vinyl and compression fit. Adding the additional materials will compensate for stretching which occurs during installation.

Installation (Cont'd)

Boston 1000 Series

NOTE: Flexible top: Over cut vinyl 1/8" for every 4' section for the flexible top to ensure a proper fit.

NOTE: Rigid Top: Do not over cut.

Installation



1. Attach the base and end/corner cap to the desired surface by inserting #8 pan head screws through the pre-slotted holes in both the end cap and the base. Insert screws through the two holes of end cap and tighten.



- 2a. **Flexible Top:** Butt end of the vinyl top against end/corner cap. While applying pressure, bend back vinyl top so that vinyl legs are positioned within the base grooves. Roll vinyl top over full length of base, then tap with rubber mallet to ensure vinyl is securely locked into the base.

- 2b. **Rigid Top:** Snap the Rigid Top over the Rigid Base.



3. If necessary wipe clean with any household cleaning product.

Helpful Hints:

- For best results, before cutting, install a scrap piece of base into vinyl top to achieve a clean cut.
- Set the uncoiled flexible vinyl at room temperature 24 hours prior to installation.
- Lubricate the inside of the vinyl with soapy water or silicone before installing.
- Over cut the flexible vinyl and compression fit. Adding the additional materials will compensate for stretching which occurs during installation.

WARNING!

Do NOT apply thread sealer to ABS P-Trap.



Plumbing

Waste Outlet and P-TRAP

The waste outlet is located off the center of the case on one side allowing drip piping to be run lengthwise under the fixture.

P-traps must be installed at the base of all refrigerated cases. The 1 ½" P-TRAP and threaded adapter must be installed to prevent air leakage and insect entrance into the fixture.

Installing Condensate Drain

Poorly or improperly installed condensate drains can seriously interfere with the operation of this refrigerator, and result in costly maintenance and product losses. Please follow the recommendations listed below when installing condensate drains to insure a proper installation:

1. Never use pipe for condensate drains smaller than the nominal diameter of the pipe or P-TRAP supplied with the case.
2. When connecting condensate drains, the P-TRAP must be used as part of the condensate drain to prevent air leakage or insect entrance. Store plumbing system floor drains should be at least 14" off the center of the case to allow use of the P-TRAP pipe section. Never use two water seals in series in any one line. Double P-TRAPS in series will cause a lock and prevent draining.
3. Always provide as much down hill slope ("fall") as possible; 1/8" per foot is the preferred minimum. PVC pipe, when used, must be supported to maintain the 1/8" pitch and to prevent warping.
4. Avoid long runs of condensate drains. Long runs make it impossible to provide the "fall" necessary for good drainage.
5. Provide a suitable air break between the flood rim of the floor drain and outlet of condensate drain. 1" is ideal.
6. Prevent condensate drains from freezing:
 - a. Do not install condensate drains in contact with non-insulated suction lines. Suction lines should be insulated with a non-absorbent insulation material such as Armstrong's Armaflex.
 - b. Where condensate drains are located in dead air spaces (between refrigerators or between a refrigerator and a wall), provide means to prevent freezing. The water seal should be insulated to prevent condensation.

Refrigeration

Refrigerant Type

The standard refrigerant will be specified on the serial plate based per customer order. Check the serial plate on the case for information.

Piping

The refrigerant line outlets are located under the case. Locate first the electrical box, the outlets are then on the same side of the case, but at the opposite end. Insulate suction lines to prevent condensation drippage.

Refrigeration Lines

<u>Liquid</u>	<u>Suction</u>
3/8" O.D.	5/8" O.D.

NOTE: The standard coil is piped at 5/8" (suction); however, the store tie-in may vary depending on the number of coils and the draw the case has. Depending on the case setup, the connecting point in the store may be 5/8", 7/8", or 1 1/8". Refer to the particular case you are hooking up.

Refrigerant lines should be sized as shown on the refrigeration legend furnished by the store.

Oil traps must be installed at the base of all suction line vertical risers on refrigerated cases.

Pressure drop can rob the system of capacity. To keep the pressure drop to a minimum, keep refrigerant line run as short as possible, using the minimum number of elbows. Where elbows are required, use long radius elbows only.

Control Settings

See Q3-SS technical data sheet for the appropriate settings for your merchandiser. Maintain these parameters to achieve near constant product temperatures. Product temperature should be measured first thing in the morning, after having been refrigerated overnight. For all multiplexing, defrost should be time terminated. Defrost times should be as directed in the Q3-SS technical data sheet. The number of defrosts per day should never change. The duration of the defrost cycle may be adjusted to meet conditions present at your location.

Access to TEV Valves and Drain Lines

Mechanical - Remove product from case. Remove pans. TX valve (mechanical only) and drain are located under the pans within the case.

Electronic - The electronic expansion valve master and slave cylinder(s) are located within the electrical access panel(s) in the rear of case. Rear panels lift up and out.

NOTE: Duplex receptacles must be detached before removing rear panels.

Electronic Expansion Valve (Optional)

A wide variety of electronic expansion valves and case controllers can be utilized. Please refer to EEV and controller manufacturers information sheet. Sensors for electronic expansion valves will be installed on the coil inlet, coil outlet, and in the discharge air. (Some supermarkets require a 4th sensor in the return air). Case controllers will be located in the electrical raceway or under the case.

Spec Sheets



SELF-SERVICE DELI
HUSSMANN - Q3-SS (CHINO)

REVISION DATE 01/31/17



Husmann refrigerated merchandisers configured for sale for use in the United States meet or surpass the requirements of the DOE 2017 energy efficiency standards.

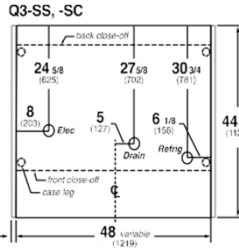
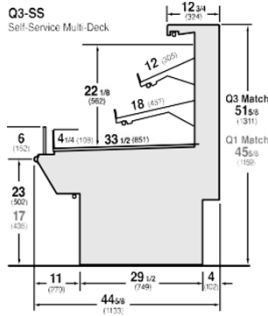
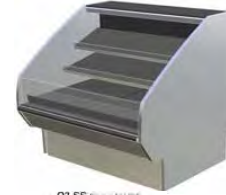

REFRIGERATION DATA:

CASE LENGTHS/ WEDGES	CASE USAGE	CAPACITY *** (BTU/HR/FT) (TOTAL FOR WEDGES)		TEMPERATURE (°F)			VELOCITY (FT/MIN)
		RATING CONDITION		EVAPORATOR		DISCHARGE AIR ** (°F)	
		NSF 7	AHRI 1200	NSF 7	AHRI 1200	NSF 7	
4,5,6,8,10,12	SS DELI	850	850	20	20	28-32	150-200
4,5,6,8,10,12	MEAT	880	850	18	20	26-30	150-200
22.5° IS	SS DELI	2700	2700	20	20	28-32	150-200
22.5° OS	SS DELI	2600	2600	20	20	28-32	150-200
45° IS	SS DELI	1610	1610	20	20	28-32	150-200
45° OS	SS DELI	1376	1376	20	20	28-32	150-200
90° OS	SS DELI	3200	3200	20	20	28-32	150-200
REAR STORAGE	SS DELI	100	90	20	26	30-34	380-600

CASE LENGTHS	EST. REFG. CHRG. 404A (LBS)	GLYCOL (20°F INLET, 6° RISE)		GLYCOL (20°F INLET, 6° RISE)	
		FRONT		REAR STORAGE	
		GPM	PSI	GPM	PSI
4'	0.5	1.3	3.4	0.1	0.0
5'	0.7	1.6	5.4	0.2	0.1
6'	0.7	1.9	7.7	0.2	0.2
8'	1.0	2.5	3.5	0.3	0.4
10'	1.4	3.0	6.2	0.3	0.6
12'	1.5	3.6	7.1	0.4	0.8
22.5° IS	0.3	0.9	1.7	N/A	N/A
22.5° OS	0.3	0.8	1.6	N/A	N/A
45° IS	0.3	0.5	0.8	N/A	N/A
45° OS	0.2	0.4	0.4	N/A	N/A
90° OS	0.3	1.0	2.0	N/A	N/A

**FRONT DISCHARGE AIR MEASURED INSIDE AIR CURTAIN HONEYCOMB

***REFRIGERATION NOTES:

- 1) BTU'S INCLUDE CANOPY LIGHTS. ADD 10 BTU'S/SHELF/FT FOR EACH SHELF (LIGHT)
- 2) AHRI 1200 RATING POINT FOR ENERGY CONSUMPTION COMPARISON ONLY
- 3) USE DEW POINT FOR HIGH GLIDE REFRIGERANTS. CARE SHOULD BE TAKEN TO USE THE DEW POINT IN P/T TABLES FOR MEASURING AND ADJUSTING SUPERHEAT. ADJUST EVAPORATOR PRESSURE AS NEEDED TO MAINTAIN THE DISCHARGE AIR TEMPERATURE SHOWN.
- 4) RATING CONDITION IS NSF TYPE I, 75°F/55% RH.

REFRIGERATION DATA CONTINUED:

LOCATION	ELEC. THERMOSTAT / AIR SENSOR SETTINGS		DEFROST TYPE	TIME (MIN)	DEFROST FREQUENCY (#/DAY)	TERM. TEMP (°F) COIL ONLY	DRIP TIME	DEFROST WATER (LBS/DAY/FT)
	USAGE	CUT IN (°F)						
SELF SERVICE	SS DELI	30	27	OFF TIME	30	48	N/A	9.1
SELF SERVICE	MEAT	28	25					10.3
REAR STORAGE	DELI	35	32					0.7

END PANEL WIDTH KEY		
# OF END PNLS	END PNL WIDTH (IN.)	TOTAL ADDED LENGTH (IN.)
1	1.125	1.125
2	1.125	2.25

ELECTRICAL DATA:

STANDARD FANS, HEATERS, LED LIGHTS (115 VOLT)

CASE LENGTH	EVAPORATOR FANS				REFRIGERATED REAR STORAGE (OPTIONAL) EVAP FANS			CANOPY LIGHTS LED		OPTIONAL LED SHELF LIGHTS		MAX. LED LOAD (W/ ALL OPTIONS)		ANTI-SWEAT HEATERS (ON FAN CIRCUIT)		CONVENIENCE OUTLETS (OPTIONAL)			
	# OF EVAP FANS	BLADE DIA. (IN.)	BLADE PITCH (°)	AMPS	WATTS	# OF EVAP FANS	AMPS	WATTS	AMPS	WATTS	AMPS	WATTS	AMPS	WATTS	AMPS	WATTS	# OUTLETS	VOLTS	AMPS
4'	2	6.7	25	0.2	16	1	0.3	9	0.1	10	0.2	21	0.3	31	N/A	N/A	N/A	N/A	N/A
5'	2	6.7	20	0.2	16	1	0.3	9	0.1	13	0.1	13	0.2	26	N/A	N/A	N/A	N/A	N/A
6'	3	6.7	25	0.4	24	1	0.3	9	0.1	15	0.1	15	0.3	31	N/A	N/A	N/A	N/A	N/A
8'	4	6.7	25	0.5	32	1	0.3	9	0.2	21	0.2	21	0.4	41	N/A	N/A	N/A	N/A	N/A
10'	4	6.7	20	0.5	32	1	0.3	9	0.2	26	0.2	26	0.5	52	N/A	N/A	N/A	N/A	N/A
12'	6	6.7	25	0.7	48	1	0.3	9	0.3	31	0.2	21	0.4	51	N/A	N/A	N/A	N/A	N/A
22.5° IS	1	6.7	15	0.1	8	N/A	N/A	N/A	0.1	8	0.0	4	0.1	12	N/A	N/A	N/A	N/A	N/A
22.5° OS	2	6.7	25	0.2	16	N/A	N/A	N/A	0.1	8	0.1	10	0.2	18	N/A	N/A	N/A	N/A	N/A
45° OS	1	6.7	25	0.1	8	N/A	N/A	N/A	0.0	4	0.0	4	0.1	8	N/A	N/A	N/A	N/A	N/A
45° IS	1	6.7	25	0.1	8	N/A	N/A	N/A	0.0	4	0.1	7	0.1	11	N/A	N/A	N/A	N/A	N/A
90° OS	3	6.7	20	0.4	24	N/A	N/A	N/A	0.0	4	0.1	14	0.2	18	N/A	N/A	N/A	N/A	N/A

OPTIONAL HIGH OUTPUT LED LIGHTS (115 VOLT)

CASE LENGTH	CANOPY LIGHTS H.O. LED		OPTIONAL SHELF		MAX. H.O. LED LOAD	
	AMPS	WATTS	AMPS	WATTS	AMPS	WATTS
4'	0.1	15	0.3	30	0.4	46
5'	N/A	N/A	N/A	N/A	N/A	N/A
6'	0.2	26	0.2	26	0.5	52
8'	0.3	30	0.3	30	0.5	61
10'	N/A	N/A	N/A	N/A	N/A	N/A
12'	0.4	46	0.3	30	0.7	76
22.5° IS	N/A	N/A	N/A	N/A	N/A	N/A
22.5° OS	N/A	N/A	N/A	N/A	N/A	N/A
45° OS	N/A	N/A	N/A	N/A	N/A	N/A
45° IS	N/A	N/A	N/A	N/A	N/A	N/A
90° OS	N/A	N/A	N/A	N/A	N/A	N/A

Spec Sheet (Cont'd)



SELF-SERVICE DELI
HUSSMANN - Q3-SS-S

REVISION DATE 10/08/19



Hussmann refrigerated merchandisers configured for sale for use in the United States meet or surpass the requirements of the DOE 2017 energy efficiency standards.

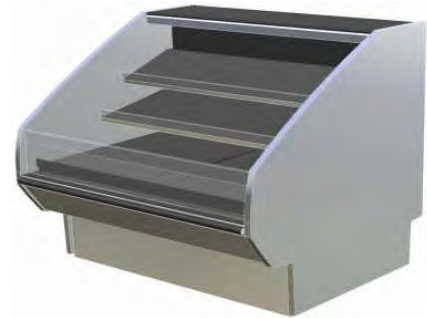
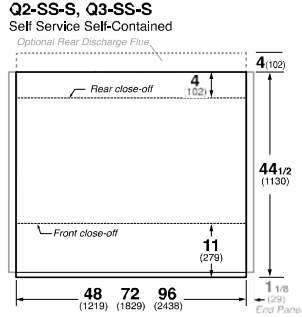
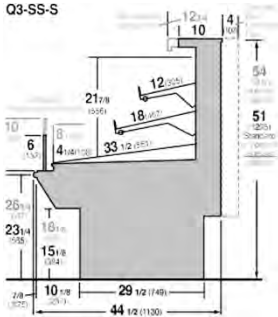

REFRIGERATION DATA:

CASE LENGTHS	CASE USAGE	CONVENTIONAL CAPACITY ** (BTU/HR/FT)	DISCHARGE AIR * (°F) (SEE SETPOINTS BELOW)	VELOCITY (FT/MIN)
3',4',5',6',8'	SS DELI	1040	22-26	150-200

*FRONT DISCHARGE AIR MEASURED INSIDE AIR CURTAIN HONEYCOMB

**REFRIGERATION NOTES:

- 1) CAPACITY FOR REFERENCE ONLY
- 2) USE DEW POINT FOR HIGH GLIDE REFRIGERANTS. CARE SHOULD BE TAKEN TO USE THE DEW POINT IN P/T TABLES FOR MEASURING AND ADJUSTING SUPERHEAT.
- 3) RATING CONDITION IS NSF TYPE I, 75°F/55% RH

REFRIGERATION DATA CONTINUED:

CONTROLLER / AIR SENSOR SETTINGS			DEFROST TYPE	FAILSAFE TIME (MIN)	DEFROST FREQUENCY (#/DAY)	TERM. TEMP (°F) AIR	DRIP TIME (MIN)	DEFROST WATER (LBS/DAY/FT)
USAGE	SET POINT (°F)	DIFFERENTIAL (°F)						
MEAT	20	8	OFF TIME	50	4	48	NA	4.2
DELI	24	8						
PRODUCE	28	8						

END PANEL WIDTH KEY		
# OF END PNLS	END PNL WIDTH (IN.)	TOTAL ADDED LENGTH (IN.)
1	1.125	1.125
2	1.125	2.25

ELECTRICAL DATA:

STANDARD FANS, HEATERS, LED LIGHTS (115 VOLT)

CASE LENGTH	EVAPORATOR FANS					CANOPY LIGHTS LED		OPTIONAL LED SHELF LIGHTS		MAX. LED LOAD (W/ ALL OPTIONS)		ANTI-SWEAT HEATERS (OPTIONAL)		CONVENIENCE OUTLETS (OPTIONAL)		
	# OF EVAP FANS	BLADE DIA. (IN.)	BLADE PITCH (°)	AMPS	WATTS	AMPS	WATTS	AMPS	WATTS	AMPS	WATTS	AMPS	WATTS	# OUTLETS	VOLTS	AMPS
3'	2	6.7	25	0.24	16	0.17	19	0.13	15	0.30	35	0.17	20	N/A	N/A	N/A
4'	2	6.7	25	0.24	16	0.23	27	0.18	21	0.41	48	0.17	20	N/A	N/A	N/A
5'	2	6.7	20	0.24	16	0.30	34	0.23	26	0.52	60	0.26	30	N/A	N/A	N/A
6'	3	6.7	25	0.36	24	0.34	39	0.27	31	0.60	69	0.26	30	N/A	N/A	N/A
8'	4	6.7	25	0.48	32	0.47	54	0.36	41	0.83	95	0.35	40	N/A	N/A	N/A

CONDENSING UNIT AND EVAPORATIVE PANS





CASE LENGTH	CONDENSING UNIT					EVAPORATIVE PAN		NEMA PLUG	EST. REFG. CHR.G. (LBS)
	NOM. HP	REFRIG.	HZ/PH	VOLTS	RLA	AMPS	WATTS		
3'	1/3	R-404A	60 / 1	115	7.2	8.3	1000	L5-30P	3.3
4'	1/2		60 / 1	115	10.5	12.5	1500	L5-30P	3.7
5'	3/4		60 / 1	240	6.8	6.3	1500	L8-20P	5.8
6'	3/4		60 / 1	240	9.0	6.3	1500	L14-30P	5.8
8'	1		60 / 1	240	10.0	6.3	1500	L14-30P	6.6
3'	TBD		TBD	TBD	TBD	TBD	TBD	TBD	TBD
4'	1/2	R-448A	60 / 1	115	10.5	12.5	1500	L5-30P	3.7
5'	3/4		60 / 1	240	9.0	6.3	1500	L8-20P	2.8
6'	3/4		60 / 1	240	9.0	6.3	1500	L14-30P	3.0
8'	1-3/4		60 / 1	240	10.0	6.3	1500	L14-30P	3.7

OPTIONAL HIGH OUTPUT LED LIGHTS (115 VOLT)

CASE LENGTH	CANOPY LIGHTS H.O. LED		OPTIONAL SHELF		MAX. H.O. LED LOAD	
	AMPS	WATTS	AMPS	WATTS	AMPS	WATTS
3'	0.21	24	0.32	36	0.52	60
4'	0.28	32	0.35	41	0.63	73
5'	N/A	N/A	N/A	N/A	N/A	N/A
6'	0.41	47	0.29	34	0.70	81
8'	0.56	64	0.44	51	1.00	115

XR75CX Digital Controller for Medium-Low Temperature Refrigeration Applications Installation and Operation Manual



- ①  Open Camera
- ②  iPhone User
Hold the camera up to the QR code
-  Android User
Open QR Code Reader app if necessary.
Hold the camera up to the QR code
- ③  Tap the notification to be taken to the destination of the QR code

Dixell Controller Settings

P/N:PROGRAM KEY Q2-SSM(X)S				
Parameter	Description	Set Value	Default Value	Function
SEt	Set point	21	-5	Compressor cut out
Hy	Differential	8	2	Compressor cut in is setpoint +differential(Hy). Cut out is setpoint
P2P	Evaporator probe presence	Y	Y	n=n not present. Defrost stops by time; y = present, defrost stops by temp
<u>PbC</u>	<u>Type of probe</u>	<u>CtC</u>	<u>nTC</u>	(nTC, CtC) It allows to set the kind of probe used by the instrument: nTC = NTC-EU probe, CtC = NTC-US probe. Set this PbC parameter to CtC to support standard CPC temp sensors - factory default.
CF	Temperature measurement unit	°F	°F	°C = Celsius °F = Fahrenheit (CAUTION! When the measurement unit is changed, the setpoint and the values of the parameters Hy, LS, US, ot, ALU and ALL have to be checked and modified if necessary).
rES	Resolution	in	dE	(in = 1°C; dE = 0.1°C) Allows decimal point display.
dFP	Probe selection for defrost	P2	P2	nP = no probe P1 = thermostat probe P2 = evaporator probe P3 = configurable probe P4 = probe on Hot Key plug
dtE	Defrost termination temperature	48	8	(-50 to 50°C; -58 to 122°F) Sets the temperature measured by the evaporator probe, which causes the end of defrost.
idF	Interval between defrost cycles	6	6	(0 to 120 hr) Determines the time interval between the beginning of two defrost cycles.
MdF	(Maximum) length of Defrost	30	30	When P2P = n, (not evaporator probe: timed defrost) it sets the defrost duration, when P2P = y (defrost end based on temperature) it sets the maximum length for defrost.

Dixell Controller Settings(Cont'd)

i2F	Second Digital Input	bAL	EAL	(EAL; bAL; PAL; dor; dEF; ES; AUS; Htr; FAn; HdF; onF) EAL = external alarm: "EA" message is displayed; bAL = serious alarm "CA" message is displayed; PAL = pressure switch alarm, "CA" message is displayed; dor = door switch function; dEF = activation of a defrost cycle; ES = energy saving; AUS = auxiliary relay activation with oA2=AUS; Htr = type of inverting action (cooling or heating); FAn = fan; onF = to switch the controller OFF
did	Digital Input	0	15	(0 to 255 min) Delay between the detection of the external alarm condition and its signaling. When i2F= PAL, it is the interval of time to calculate the number of pressure switch activation
i2P	Second digital input polarity (18-19)	OP	CL	(0 to 15) Number of activation, during the did interval, before signaling an alarm event (i2F=PAL). If the nPS activation during did time is reached, switch OFF and ON the instrument to restart normal regulation.
<u>oNF</u>	<u>ON/OFF key enabling</u>	<u>oFF</u>	<u>n0</u>	(nU; oFF; ES) nU = disabled; oFF = enabled; ES = not set it

Danfoss Controller Operations

ENGINEERING
TOMORROW





Danfoss

User Guide

Controller for temperature control AK-CC210B, SW 1.0x

ADAP-KOOL® Refrigeration Control System



- ①  Open Camera
- ②  iPhone User
Hold the camera up to the QR code
-  Android User
Open QR Code Reader app if necessary.
Hold the camera up to the QR code
- ③  Tap the notification to be taken to the destination of the QR code

Danfoss Controller Settings

Q3-SS					PGM0037A01	
STANDARD CASE REV A 05/14/20						
Parameter	Code	Min	Max	Default	Actual (°C)	Actual (°F)
Temperature (set point)						
Produce (Type I)	---	-50.0°C	50.0°C	2.0°C	-2.2	28
Deli (Type I)	---	-50.0°C	50.0°C	2.0°C	-4.4	24
Meat (Type I)	---	-50.0°C	50.0°C	2.0°C	-6.7	20
Thermostat						
Differential	r01	0.1 K	20.0K	2.0 K	4.4	8
Max. limitation of setpoint setting	r02	-49.0°C	50°C	50.0°C	2.2	36
Min. limitation of setpoint setting	r03	-50.0°C	49.0°C	-50.0°C	-6.7	20
Adjustment of temperature indication	r04	-20.0 K	20.0 K	0.0 K	0.0 K	
Temperature unit (°C=0/°F=1)	r05	0	1	0	1	
Correction of the signal from S4	r09	-10.0 K	+10.0 K	0.0 K	0.0 K	
Correction of the signal from S3	r10	-10.0 K	+10.0 K	0.0 K	0.0 K	
Manual service, stop regulation, start regulation (-1, 0, 1)	r12	-1	1	0	1	
Displacement of reference during night operation	r13	-10.0 K	10.0 K	0.0 K	0.0 K	
Definition and weighting, if applicable, of thermostat sensors - S4% (100%=S4, 0%=S3)	r15	0%	100%	100%	100%	
The heating function is started a number of degrees below the thermostats cutout temperature	r36	-15.0 K	-3.0 K	-15.0 K	-15.0 K	
Activation of reference displacement r40	r39	OFF	ON	OFF	OFF	
Value of reference displacement (activate via r39 or DI)	r40	-50.0 K	50.0 K	0.0 K	0.0 K	
Alarm						
Delay for temperature alarm	A03	0 min	240 min	30 min	30 min	
Delay for door alarm	A04	0 min	240 min	60 min	60 min	
Delay for temperature alarm after defrost	A12	0 min	240 min	90 min	60	
High alarm limit	A13	-50.0°C	50.0°C	8.0°C	5.0	41
Low alarm limit	A14	-50.0°C	50.0°C	-30.0°C	-9.4	15
Alarm delay DI1	A27	0 min	240 min	30 min	30 min	
Alarm delay DI2	A28	0 min	240 min	30 min	30 min	
Signal for alarm thermostat. S4% (100%=S4, 0%=S3)	A36	0%	100%	100%	100%	
Compressor						
Min. ON-time	c01	0 min	30 min	0 min	1	
Min. OFF-time	c02	0 min	30 min	0 min	2	
Time delay for cutin of comp.2	c05	0 sec	999 sec	0 sec	0 sec	
Compressor relay 1 must cutin and out inversely (NC-function)	c30	0 OFF	1 ON	0 OFF	0 OFF	
Defrost						
Defrost method (none/EL/GAS/BRINE)	d01	no	bri	EL	EL	
Defrost stop temperature	d02	0.0°C	25.0°C	6.0°C	11.1	52
Interval between defrost starts	d03	0 hours	240 hours	8 hours	6	
Max. defrost duration	d04	0 min	180 min	45 min	30	
Displacement of time on cutin of defrost at start-up	d05	0 min	240 min	0 min	0 min	
Drip off time	d06	0 min	60 min	0 min	0 min	
Delay for fan start after defrost	d07	0 min	60 min	0 min	0 min	
Fan start temperature	d08	-15.0°C	0.0°C	-5.0°C	-5.0°C	
Fan cutin during defrost 0: Stopped 1: Running 2: Running during pump down and defrost	d09	0	2	1	1	
Defrost Sensor (0=time, 1=S5. 2=S4)	d10	0	2	0	1	
Pump down delay	d16	0 min	60 min	0 min	0 min	
Drain delay	d17	0 min	60 min	0 min	0 min	
Max. aggregate refrigeration time between two defrosts	d18	0 hours	48 hours	0 hours		
Defrost on demand - S5 temperature's permitted variation during frost build-up. On central plant choose 20 K (=off)	d19	0.0 K	20.0 k	20.0 K		
Delay of hot gas defrost	d23	0 min	60 min	0 min	0 min	
Fan						
Fan stop at cutout compressor	F01	no	yes	no	no	
Delay of fan stop	F02	0 min	30 min	0 min	0 min	
Fan stop temperature (S5)	F04	-50.0°C	50.0°C	50.0°C	50.0°C	
HACCP						
Actual temperature measurement for the HACCP	h01					

Danfoss Controller Settings(Cont'd)

Last registered peak temperature	h10					
Selection of function and sensor for the HACCP HACCP function. 1 = S4 used (maybe also S3). 2 = S5	h11	0	2	0	0	
Alarm limit for the HACCP function	h12	-50.0°C	50.0°C	8.0°C	8.0°C	
Time delay for the HACCP alarm	h13	0 min.	240 min.	30 min.	30 min.	
Select signal for the HACCP function. S4% (100% = S4,	h14	0%	100%	100%	100%	
Real time clock						
Six start times for defrost. Setting of hours. 0=OFF	t01-t06	0 hours	23 hours	0 hours	0 hours	
Six start times for defrost. Setting of minutes. 0=OFF	t11-t16	0 min	59 min	0 min	0 min	
Clock - Setting of hours	t07	0 hours	23 hours	0 hours	0 hours	
Clock - Setting of minute	t08	0 min	59 min	0 min	0 min	
Clock - Setting of date	t45	1	31	1	1	
Clock - Setting of month	t46	1	12	1	1	
Clock - Setting of year	t47	0	99	0	0	
Miscellaneous						
Delay of output signals after start-up	o01	0 s	600 s	5 s	5 s	
Input signal on DI1. Function: Network address	o02	1	11	0	5	
On/Off switch (Service Pin message)	o03	0	240	0	0	
Access code 1 (all settings)	o04	OFF	ON	OFF	OFF	
Used sensor type (Pt /PTC/NTC)	o05	0	100	0	0	
Display step = 0.5 (normal 0.1 at Pt sensor)	o06	Pt	ntc	Pt	Pt	
Max hold time after coordinated defrost	o15	no	yes	no	no	
Select signal for display view. S4% (100%=S4, 0%=S3)	o16	0 min	60 min	20	20	
Input signal on DI2. Function:	o17	0%	100%	100%	100%	
Configuration of light function (relay 4)	o37	0	12	0	0	
Activation of light relay (only if o38=2)	o38	1	3	1	1	
Rail heat On time during day operations	o39	OFF	ON	OFF	OFF	
Rail heat On time during night operations	o41	0%	100%	100	100	
Rail heat period time (On time + Off time)	o42	0%	100%	100	100	
Case cleaning. 0=no case cleaning. 1=Fans only. 2=All	o43	6 min	60 min	10 min	10 min	
Selection of EL diagram. See overview page 6	o46	0	2	0	0	
Download a set of predetermined settings. See	o61	1	10	1	1	
Access code 2 (partly access)	o62	0	6	0	0	
Save the controllers present settings to the	o64	0	100	0	0	
Load a set of settings from the programming key	o65	0	25	0	0	
Replace the controllers factory settings with the	o66	0	25	0	0	
Replace the controllers factory settings with the	o67	OFF	On	OFF	OFF	
Service						
Status codes are shown on page 17	S0-S33					
Temperature measured with S5 sensor	u09					
Status on DI1 input. on/1=closed	u10					
Temperature measured with S3 sensor	u12					
Status on night operation (on or off) 1=closed	u13					
Temperature measured with S4 sensor	u16					
Thermostat temperature	u17					
Read the present regulation reference	u28					
Status on DI2 output. on/1=closed	u37					
Temperature shown on display	u56					
Measured temperature for alarm thermostat	u57					
Status on relay for cooling	u58					
Status on relay for fan	u59					
Status on relay for defrost	u60					
Status on relay for railheat	u61					
Status on relay for alarm	u62					
Status on relay for light	u63					
Status on relay for valve in suction line	u64					
Status on relay for compressor 2	u67					

Danfoss Controller Settings

Q-SS-2 (Q1, Q2, Q3)					PGM0046A01	
					STANDARD CASE REV A 05/14/20	
Parameter	Code	Min	Max	Default	Actual (°C)	Actual (°F)
Temperature (set point)						
Produce (Type I)	---	-50.0°C	50.0°C	2.0°C	-7.8	18
Thermostat						
Differential	r01	0.1 K	20.0K	2.0 K	4.4	8
Max. limitation of setpoint setting	r02	-49.0°C	50°C	50.0°C	2.2	36
Min. limitation of setpoint setting	r03	-50.0°C	49.0°C	-50.0°C	-7.8	18
Adjustment of temperature indication	r04	-20.0 K	20.0 K	0.0 K	0.0 K	
Temperature unit (°C=0/°F=1)	r05	0	1	0	1	
Correction of the signal from S4	r09	-10.0 K	+10.0 K	0.0 K	0.0 K	
Correction of the signal from S3	r10	-10.0 K	+10.0 K	0.0 K	0.0 K	
Manual service, stop regulation, start regulation (-1, 0, 1)	r12	-1	1	0	1	
Displacement of reference during night operation	r13	-10.0 K	10.0 K	0.0 K	0.0 K	
Definition and weighting, if applicable, of thermostat sensors - S4% (100%=S4, 0%=S3)	r15	0%	100%	100%	100%	
The heating function is started a number of degrees below the thermostats cutout temperature	r36	-15.0 K	-3.0 K	-15.0 K	-15.0 K	
Activation of reference displacement r40	r39	OFF	ON	OFF	OFF	
Value of reference displacement (activate via r39 or DI)	r40	-50.0 K	50.0 K	0.0 K	0.0 K	
Alarm						
Delay for temperature alarm	A03	0 min	240 min	30 min	30 min	
Delay for door alarm	A04	0 min	240 min	60 min	60 min	
Delay for temperature alarm after defrost	A12	0 min	240 min	90 min	60	
High alarm limit	A13	-50.0°C	50.0°C	8.0°C	5.0	41
Low alarm limit	A14	-50.0°C	50.0°C	-30.0°C	-9.4	15
Alarm delay DI1	A27	0 min	240 min	30 min	30 min	
Alarm delay DI2	A28	0 min	240 min	30 min	30 min	
Signal for alarm thermostat. S4% (100%=S4, 0%=S3)	A36	0%	100%	100%	100%	
Compressor						
Min. ON-time	c01	0 min	30 min	0 min	1	
Min. OFF-time	c02	0 min	30 min	0 min	2	
Time delay for cutin of comp.2	c05	0 sec	999 sec	0 sec	0 sec	
Compressor relay 1 must cutin and out inversely (NC-function)	c30	0	1	0	0	
		OFF	ON	OFF	OFF	
Defrost						
Defrost method (none/EL/GAS/BRINE)	d01	no	bri	EL	EL	
Defrost stop temperature	d02	0.0°C	25.0°C	6.0°C	11.1	52
Interval between defrost starts	d03	0 hours	240 hours	8 hours	6	
Max. defrost duration	d04	0 min	180 min	45 min	30	
Displacement of time on cutin of defrost at start-up	d05	0 min	240 min	0 min	0 min	
Drip off time	d06	0 min	60 min	0 min	0 min	
Delay for fan start after defrost	d07	0 min	60 min	0 min	0 min	
Fan start temperature	d08	-15.0°C	0.0°C	-5.0°C	-5.0°C	
Fan cutin during defrost	d09	0	2	1	1	
0: Stopped 1: Running 2: Running during pump down and defrost						
Defrost Sensor (0=time, 1=S5. 2=S4)	d10	0	2	0	0	
Pump down delay	d16	0 min	60 min	0 min	0 min	
Drain delay	d17	0 min	60 min	0 min	0 min	
Max. aggregate refrigeration time between two defrosts	d18	0 hours	48 hours	0 hours		
Defrost on demand - S5 temperature's permitted variation during frost build-up. On central plant choose 20 K (=off)	d19	0.0 K	20.0 k	20.0 K		
Delay of hot gas defrost	d23	0 min	60 min	0 min	0 min	
Fan						
Fan stop at cutout compressor	F01	no	yes	no	no	
Delay of fan stop	F02	0 min	30 min	0 min	0 min	
Fan stop temperature (S5)	F04	-50.0°C	50.0°C	50.0°C	50.0°C	
HACCP						
Actual temperature measurement for the HACCP	h01					
Last registered peak temperature	h10					
Selection of function and sensor for the HACCP HACCP function. 1 = S4 used (maybe also S3). 2 = S5	h11	0	2	0	0	
Alarm limit for the HACCP function	h12	-50.0°C	50.0°C	8.0°C	8.0°C	

Danfoss Controller Settings

Select signal for the HACCP function. S4% (100% = S4, 0% = S3)	h14	0%	100%	100%	100%	
Real time clock						
Six start times for defrost. Setting of hours. 0=OFF	t01-t06	0 hours	23 hours	0 hours	0 hours	
Six start times for defrost. Setting of minutes. 0=OFF	t11-t16	0 min	59 min	0 min	0 min	
Clock - Setting of hours	t07	0 hours	23 hours	0 hours	0 hours	
Clock - Setting of minute	t08	0 min	59 min	0 min	0 min	
Clock - Setting of date	t45	1	31	1	1	
Clock - Setting of month	t46	1	12	1	1	
Clock - Setting of year	t47	0	99	0	0	
Miscellaneous						
Delay of output signals after start-up	o01	0 s	600 s	5 s	5 s	
Input signal on DI1. Function:	o02	1	11	0	5	
Network address	o03	0	240	0	0	
On/Off switch (Service Pin message)	o04	OFF	ON	OFF	OFF	
Access code 1 (all settings)	o05	0	100	0	0	
Used sensor type (Pt /PTC/NTC)	o06	Pt	ntc	Pt	Pt	
Display step = 0.5 (normal 0.1 at Pt sensor)	o15	no	yes	no	no	
Max hold time after coordinated defrost	o16	0 min	60 min	20	20	
Select signal for display view. S4% (100%=S4, 0%=S3)	o17	0%	100%	100%	100%	
Input signal on DI2. Function:	o37	0	12	0	0	
Configuration of light function (relay 4)	o38	1	3	1	1	
Activation of light relay (only if o38=2)	o39	OFF	ON	OFF	OFF	
Rail heat On time during day operations	o41	0%	100%	100	100	
Rail heat On time during night operations	o42	0%	100%	100	100	
Rail heat period time (On time + Off time)	o43	6 min	60 min	10 min	10 min	
Case cleaning. 0=no case cleaning. 1=Fans only. 2=All	o46	0	2	0	0	
Selection of EL diagram. See overview page 6	o61	1	10	1	1	
Download a set of predetermined settings. See	o62	0	6	0	0	
Access code 2 (partly access)	o64	0	100	0	0	
Save the controllers present settings to the	o65	0	25	0	0	
Load a set of settings from the programming key	o66	0	25	0	0	
Replace the controllers factory settings with the	o67	OFF	On	OFF	OFF	
Service						
Status codes are shown on page 17	S0-S33					
Temperature measured with S5 sensor	u09					
Status on DI1 input. on/1=closed	u10					
Temperature measured with S3 sensor	u12					
Status on night operation (on or off) 1=closed	u13					
Temperature measured with S4 sensor	u16					
Thermostat temperature	u17					
Read the present regulation reference	u28					
Status on DI2 output. on/1=closed	u37					
Temperature shown on display	u56					
Measured temperature for alarm thermostat	u57					
Status on relay for cooling	u58					
Status on relay for fan	u59					
Status on relay for defrost	u60					
Status on relay for railheat	u61					
Status on relay for alarm	u62					
Status on relay for light	u63					
Status on relay for valve in suction line	u64					
Status on relay for compressor 2	u67					

Electrical

Wiring Color Code

Standard Case Wire Color Code	
<u>Color Description</u>	<u>Color</u>
■ Ground	Green
■ Anti-Sweat	Purple
■ Lights	Orange
■ Receptacles	Yellow
■ T-Stat/Solenoid 230VAC	Red/Black
■ T-Stat/Solenoid 115VAC	White/Black
■ T-Stat/Solenoid 24VAC	Red/White
■ Fan Motors	Brown
■ Blue Condensing Unit	

Use Copper Conductors Only
430-01-0338 R101003

CASE MUST BE GROUNDED

NOTE: Refer to label affixed to case to determine the actual configuration as checked in the "TYPE INSTALLED" boxes.

Electrical Circuit Identification

Standard lighting for all models will be full length fluorescent lamps located within the case at the top. The switch controlling the lights, the plug provided for digital scale, and the thermometer are located at the rear of the case mullion. The receptacle that is provided on the exterior back of these models is intended for computerized scales with a five amp maximum load, not for large motors or other high wattage appliances. It should be wired to a dedicated circuit.

Electrical Service Receptacles (When Applicable)

The receptacles located on the exterior of the merchandiser are intended for scales and lighted displays. They are not intended nor suitable for large motors or other external appliances.



DANGER
BEFORE SERVICING
ALWAYS DISCONNECT ELECTRICAL
POWER AT THE MAIN DISCONNECT
WHEN SERVICING OR REPLACING ANY
ELECTRICAL COMPONENT.
This includes (but not limited to) Fans, Heaters
Thermostats, and Lights.

Field Wiring and Serial Plate Amperage

Field Wiring must be sized for component amperes printed on the serial plate. Actual ampere draw may be less than specified. Field wiring from the refrigeration control panel to the merchandisers is required for refrigeration thermostats. Case amperes are listed on the wiring diagram, but always check the serial plate.

LED Driver Location

Drivers are located within the access panel that runs the length of the rear of the case. Refer to diagram on page 4.

Ashrae Color Code

NOTE: All other manufacturers have no standard sensor codes.

Case Control Systems SENSOR COLOR			
Manufacturer ® >	EIL	CPC	
Location			
Coil Inlet	Color	Blue	Blue
	Part#	225-01-1755	225-01-3255
Coil Outlet	Color	Red	Red
	Part#	225-01-1757	225-01-3123
Discharge Air	Color	Green	Green
	Part#	225-01-1756	225-01-3260
Return Air	Color	Purple	Green
	Part#	225-01-1758	225-01-3260
Defrost Term.	Color	White	Orange
	Part#	225-01-0650	225-01-3254
Liquid Line	Color	White	Blue
	Part#	225-01-0650	225-01-3255

Electrical Wiring Diagrams

MODEL	DESCRIPTION	SIZE	DIAGRAM #
Q3-SS REMOTE	Q3-SS-4R	4'	3014523
	Q3-SS-5R	5'	3014525
	Q3-SS-6R	6'	3014526
	Q3-SS-8R	8'	3014527
	Q3-SS-10R	10'	3014528
	Q3-SS-12R	12'	3014529
	Q3-SS-22.5 IS		3014530
	Q3-SS-22.5 OS		3014531
	Q3-SS-45 IS		3014532
	Q3-SS-45 OS		3014533
	Q3-SS-90 OS		3014534
Q3-SELF-CONTAINED CHINO (Danfoss Controller)	Q3-SS-2S	2'	3125634
	Q3-SS-4S	4'	3125635
	Q3-SS-5S	5'	3125636
	Q3-SS-6S	6'	3125637
	Q3-SS-8S	8'	3125638
Q3-SELF-CONTAINED CHINO (Dixell Controller)	Q3-SS-4S	4'	3156674
	Q3-SS-6S	6'	3157153
	Q3-SS-8S	8'	3156422
Q3-SELF-CONTAINED MEXICO (Danfoss Controller)	Q3-SS-2S	2'	3041417
	Q3-SS-4S	4'	3041418
	Q3-SS-5S	5'	3041421
	Q3-SS-6S	6'	3041419
	Q3-SS-8S	8'	3041420
Q3-SELF-CONTAINED MEXICO (Dixell Controller)	Q3-SS-4S	4'	3156882
	Q3-SS-6S	6'	3156883
	Q3-SS-8S	8'	3156881

CIRCUIT #1 LOADING	120V	150A
LI	150	

LIGHT CIRCUIT= 028A 238W



REV	ECN	DATE	REVISION DESCRIPTION	REV BY	CHKD BY	APPR BY
A	ECN-CAP-0003962	2016/09/07	RELEASED TO PRODUCTION	CB	CB	CB
B	ECN-COD-0014484	2021/11/22	NEW LIGHTS	AL	CB	CB
C	ECN-COD-0018447	2023/09/08	CHANGED FANS & LIGHTS	CB	CB	CB

CIRCUIT # 2 optional

LOADING	120V	150A
LI	150	

NOTE: FOR GFCI PROTECTION, IF MORE THAN ONE SINGLE RECEPTACLE IS USED IN CONJUNCTION WITH A GFCI DUPLEX RECEPTACLE, 'DOWNSTREAM' ON THE LOAD SIDE, THE SUM OF ALL RECEPTACLES SHOULD NOT BE MORE THAN 15A

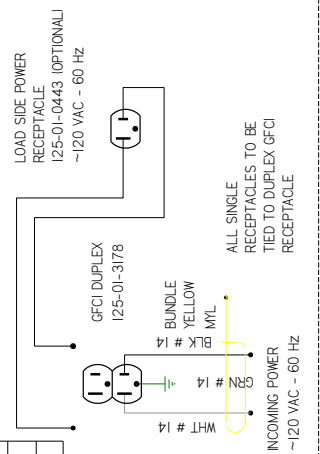

EVAP FAN MOTOR (2) 3172574 12W .08A @ 120VAC

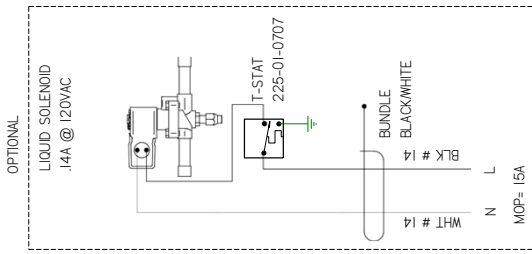
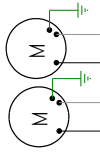

BUNDLE BROWN MBR

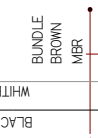

~120 VAC - 60 Hz
MCA= 020A
MOP= 15A

~120 VAC - 60 Hz
MCA= 035A
MOP= 15A

NOTES:
CASE MUST BE GROUNDED
WHEN PASSING WIRES THROUGH METAL HOLES A GROMMET MUST BE USED

HUSSMANN
DIAGRAM-03-SS-4R

MATERIAL - N/A
DATE DRAWN - 9-7-16
DRAWN BY - CRAIG BOOREY
ECN-CAP-0003962
REVIEWED BY - CRAIG BOOREY
REF -
APPROVED BY - CRAIG BOOREY
SHEET NO. 1
UNLESS OTHERWISE SPECIFIED DIMENSIONS ARE IN INCHES
TOLERANCES ARE:
FRACTIONS .015
DECIMALS .XX +03, .XXX
ANGLES
E
PROJECTION
ANGLES ± 2°

3014523



CIRCUIT #1	LOADING
120V	
LI	15.0

LIGHT CIRCUIT= 0.36A 39.2W
CANOPY LIGHTS
5 LED LIGHT - NUA

OPTIONAL SHELF LIGHTS
5 LED LIGHT - NUA

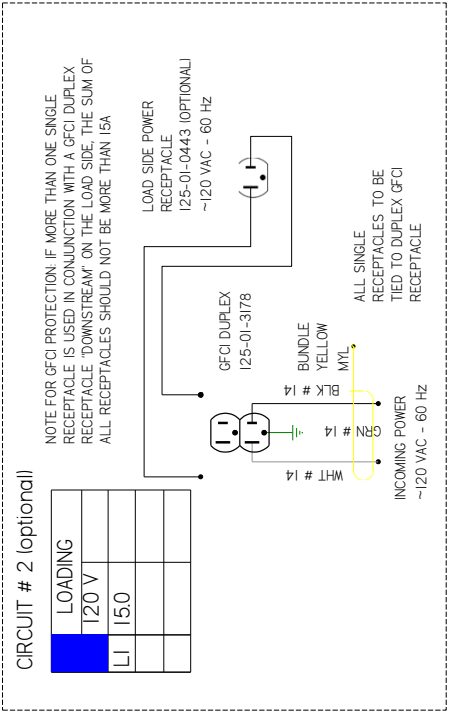
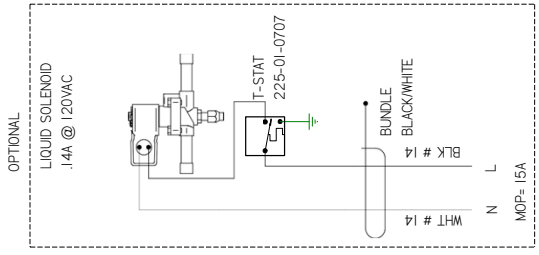
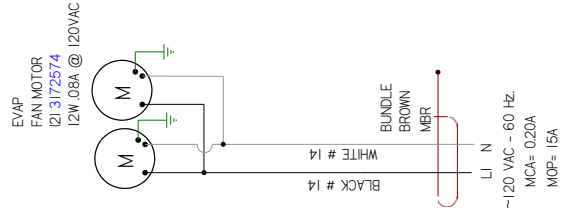
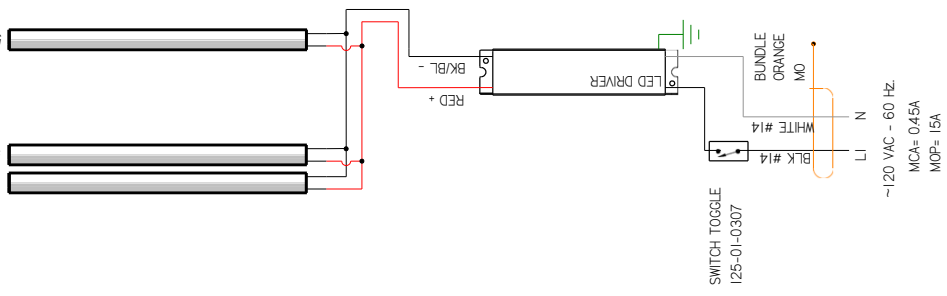

CIRCUIT # 2 optional

LOADING	
120 V	
LI	15.0

REVISION HISTORY			
REV	ECN	DATE	DESCRIPTION
A	ECN-CAP-0003962	2016/09/07	RELEASED TO PRODUCTION
B	ECN-COD-0014484	2022/11/22	NEW LIGHTS
C	ECN-COD-0018447	2023/09/18	CHANGED FANS & LIGHTS
D	ECN-COD-0018716	2023/11/01	NEW FAN MOTORS

MATERIAL - N/A
DATE DRAWN - 9-7-16
DRAWN BY - CRAIG BOOREY
REVIEWED BY - CRAIG BOOREY
APPROVED BY - CRAIG BOOREY
UNLESS OTHERWISE SPECIFIED DIMENSIONS ARE IN INCHES
TO FINANCES ARE TO THIRD PROJECTION
DECIMALS .XX +03 .XXX
+0.0
ANGLES ± 2°

HUSSMANN
DIAGRAM-Q3-SS-5R

ECN-CAP-0003962
REF -
SHEET 1 OF 1
THIRD PROJECTION

3014525 | D



CIRCUIT #1 LOADING	120V	15.0
LI		

LIGHT CIRCUIT= 0.42A 45.8W
 OPTIONAL SHELF CANOPY LIGHTS
 3 LED LIGHT - NUA
 3 LED LIGHT - NUA
 3 LED LIGHT - NUA
 3 LED LIGHT - NUA
 3 LED LIGHT - NUA
 3 LED LIGHT - NUA

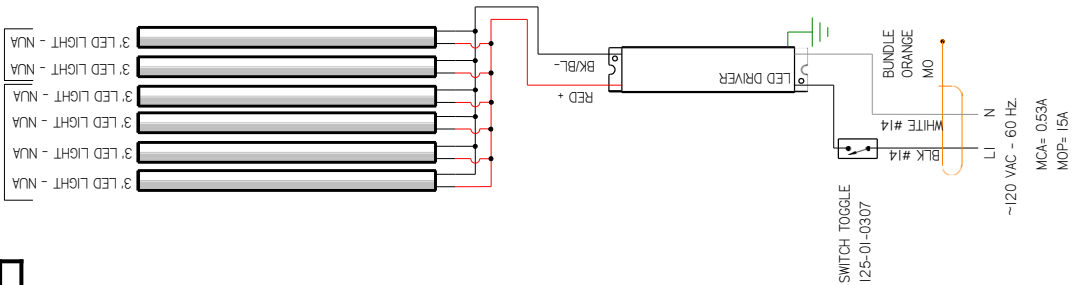

~120 VAC - 60 Hz
 MCA= 0.53A
 MOP= 15A

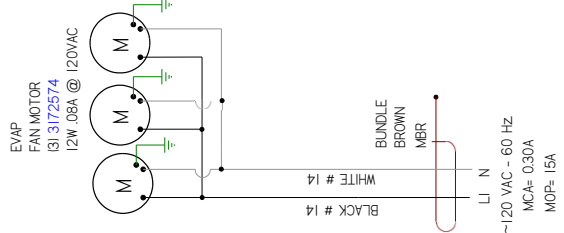

~120 VAC - 60 Hz
 MCA= 0.30A
 MOP= 15A

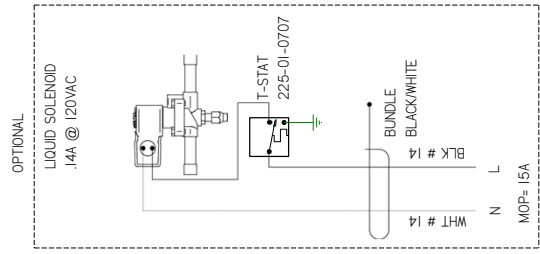

MOP= 15A

REV	ECN	DATE	REVISION DESCRIPTION	REV BY	CHKD BY	APPR BY
A	ECN-CAP-0003982	2016/09/07	RELEASED TO PRODUCTION	CB	CB	CB
B	ECN-COD-0014484	2021/11/22	NEW LIGHTS	AL	CB	CB
C	ECN-COD-0018447	2022/09/08	CHANGED FANS & LIGHTS	CB	CB	CB

CIRCUIT # 2 (optional)

LOADING	120 V	15.0
LI		

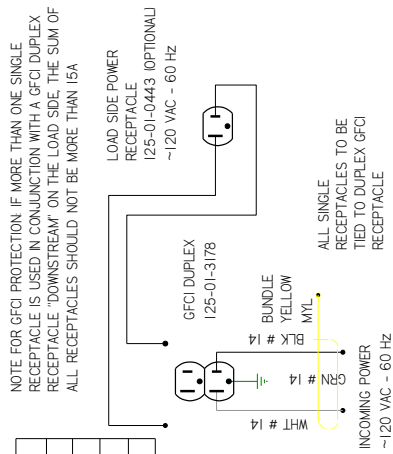

NOTE FOR GFCI PROTECTION IF MORE THAN ONE SINGLE RECEPTACLE IS USED IN CONJUNCTION WITH A GFCI DUPLEX RECEPTACLE 'DOWNSTREAM' ON THE LOAD SIDE, THE SUM OF ALL RECEPTACLES SHOULD NOT BE MORE THAN 15A.

ALL SINGLE RECEPTACLES TO BE TIED TO DUPLEX GFCI RECEPTACLE

NOTES:
 CASE MUST BE GROUNDED
 WHEN PASSING WIRES THROUGH METAL HOLES A GROMMET MUST BE USED

HUSSMANN
DIAGRAM-Q3-SS-6R

MATERIAL - N/A
 DATE DRAWN - 9-7-16
 DRAWN BY - CRAIG BOOREY
 ECN-CAP-0003982
 REF -
 APPROVED BY - CRAIG BOOREY
 SHEET 1 OF 1
 UNLESS OTHERWISE SPECIFIED DIMENSIONS ARE IN INCHES
 TO FINANCES ARE THIRD ANGLE
 DECIMALS .XX +03 .XXX
 ANGLES ± 2°
 PROJECTION

3014526 | C



CIRCUIT #1					
LOADING					
	120V				
	LI	15.0			

LIGHT CIRCUIT= 0.55A 596W

OPTIONAL SHELF LIGHTS

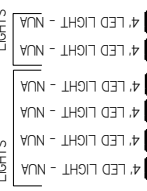

CANOPY LIGHTS

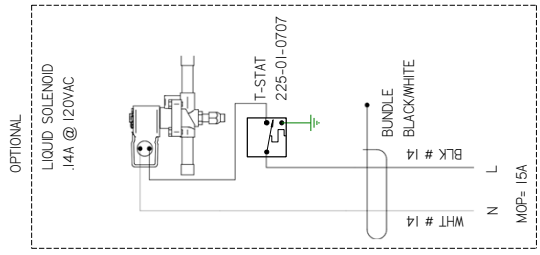
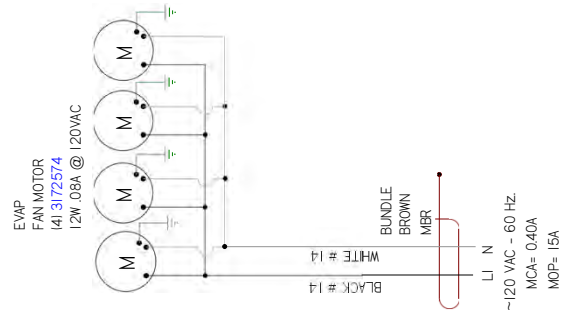
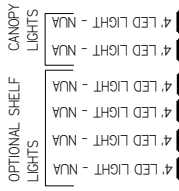

CIRCUIT # 2 optional

LOADING					
	120 V				
	LI	15.0			

NOTE FOR GFCI PROTECTION IF MORE THAN ONE SINGLE RECEPTACLE IS USED IN CONJUNCTION WITH A GFCI DUPLEX RECEPTACLE 'DOWNSTREAM' ON THE LOAD SIDE THE SUM OF ALL RECEPTACLES SHOULD NOT BE MORE THAN 15A

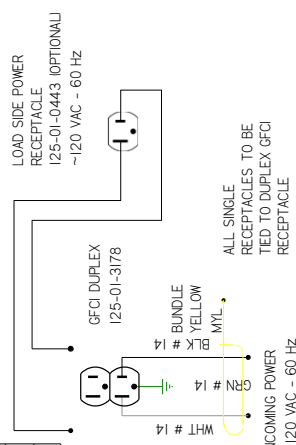

ALL SINGLE RECEPTACLES TO BE TIED TO DUPLEX GFCI RECEPTACLE

REV	ECN	DATE	REVISION DESCRIPTION	REV BY	CHKD BY	APPR BY
A	ECN-CAP-0003962	2016/09/07	RELEASED TO PRODUCTION	CB	CB	CB
B	ECN-COD-0014484	2021/11/22	NEW LIGHTS & REMOVED LED DRIVER	AL	CB	CB
C	ECN-COD-0018447	2023/02/08	CHANGED FANS & LIGHTS	CB	CB	CB

MATERIAL - N/A
 DATE DRAWN - 9-7-16
 DRAWN BY - CRAIG BOOREY
 REVIEWED BY - CRAIG BOOREY
 APPROVED BY - CRAIG BOOREY
 UNLESS OTHERWISE SPECIFIED DIMENSIONS ARE IN INCHES
 TO FINISHES ARE THIRD ANGLE PROJECTION
 DECIMALS .XX +03 .XXX
 ANGLES ± 2°

HUSSMANN
 DIAGRAM-Q3-SS-8R
 ECN-CAP-0003962
 REF -
 SHEET 1 OF 1
 DIMENSIONS ARE IN INCHES
 TO FINISHES ARE THIRD ANGLE PROJECTION
 DECIMALS .XX +03 .XXX
 ANGLES ± 2°



NOTES:
 CASE MUST BE GROUNDED
 WHEN PASSING WIRES THROUGH METAL HOLES A GROMMET MUST BE USED

CIRCUIT #1			
LOADING	120V	150V	

LIGHT CIRCUIT= 0.73A 78.4W

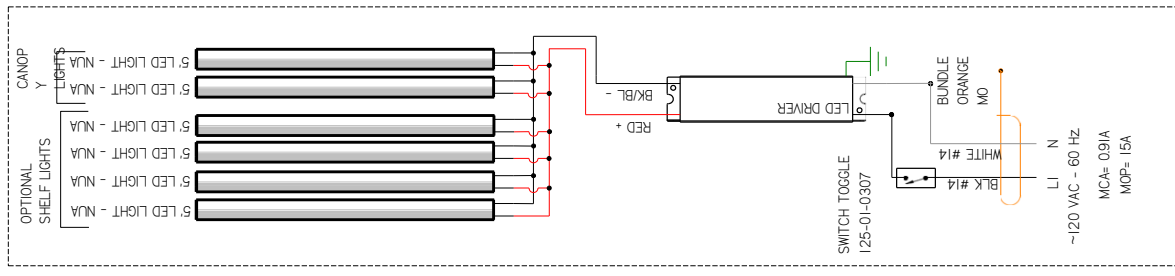

REV	ECN	DATE	REVISION DESCRIPTION	REV BY	CHKD BY	APPR BY
A	ECN-CAP-0003962	2016/09/07	RELEASED TO PRODUCTION	CB	CB	CB
B	ECN-CAP-0017670	2019/06/06	ADDED OPTIONAL ANTI-SWEAT HEATER	CB	CB	CB
C	ECN-COD-0014484	2023/01/22	NEW LIGHTS & REMOVED LED DRIVER	AL	CB	CB
D	ECN-COD-0018447	2023/09/18	CHANGED FANS & LIGHTS	CB	CB	CB
E	ECN-COD-0018726	2023/09/18	NEW FAN MOTOR	CB	CB	CB

CIRCUIT # 2 (optional)

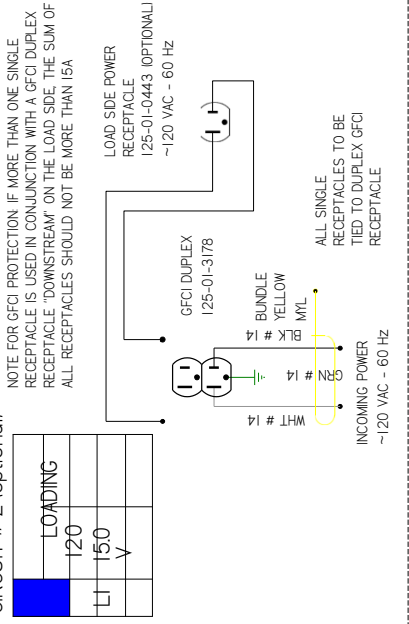

OPTIONAL

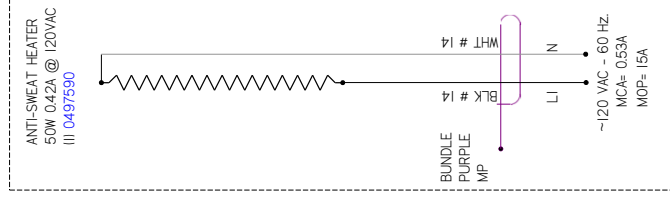

OPTIONAL

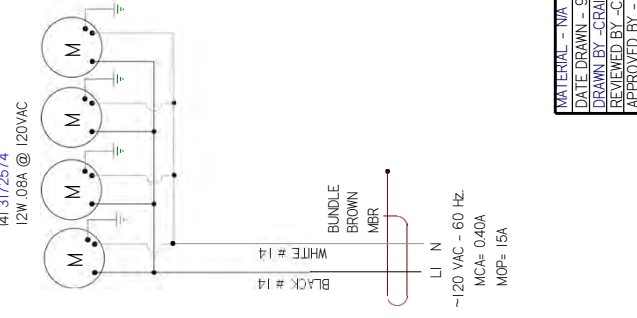

OPTIONAL

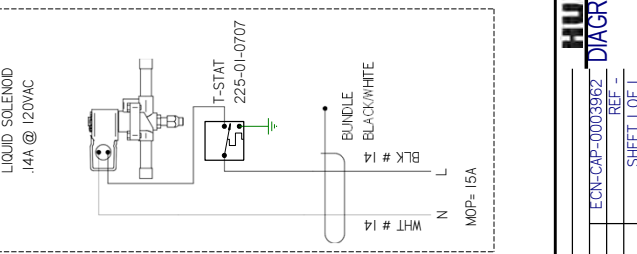

HUSSMANN
DIAGRAM-Q3-SS-10R

MATERIAL - N/A
DATE DRAWN - 9-7-16
DRAWN BY - CRAIG BOOREY
REVIEWED BY - CRAIG BOOREY
APPROVED BY - CRAIG BOOREY
UNLESS OTHERWISE SPECIFIED DIMENSIONS ARE IN INCHES
THIRD ANGLE PROJECTION
DECIMALS .XX +03 .XXX
ANGLES ± 2°

ECN-CAP-0003962
REF -
SHEET 1 OF 1
TO FRANCES ARTE
THIRD ANGLE PROJECTION

3014528 | E

NOTES:
CASE MUST BE GROUNDED
WHEN PASSING WIRES THROUGH METAL HOLES A GROMMET MUST BE USED



CIRCUIT #1			
LOADING	120	150	
	LI	LI	
	V		

CANOPY LIGHTS
OPTIONAL SHELF LIGHTS

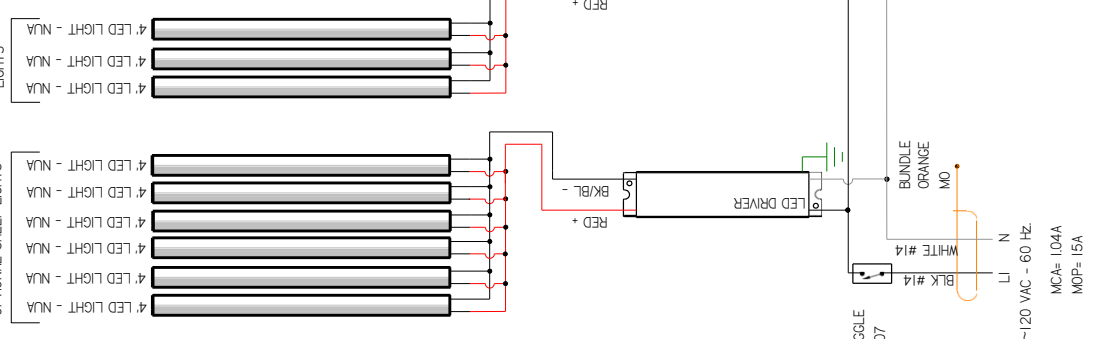

LIGHT CIRCUIT = 0.83A 89.4W

REV	ECN	DATE	REVISION DESCRIPTION	REV BY	CHKD BY	APPR BY
A	ECN-CAP-0003962	2016/09/07	RELEASED TO PRODUCTION	CB	CB	CB
B	ECN-COD-0014484	2021/11/22	NEW LIGHTS	AL	CB	CB
C	ECN-COD-0018447	2022/09/21	CHANGED FANS & LIGHTS	CB	CB	CB

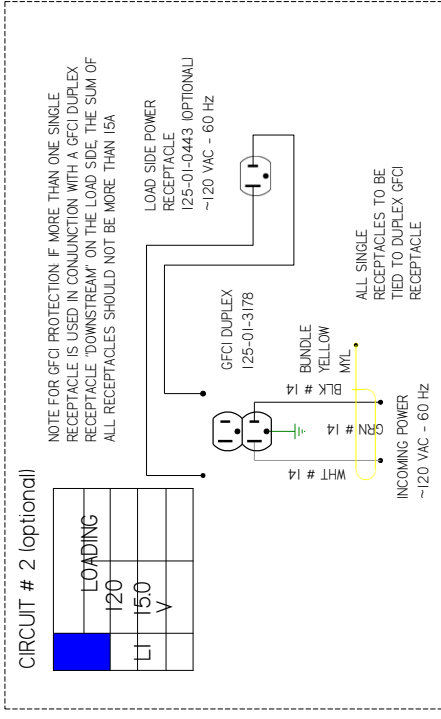

CIRCUIT # 2 (optional)

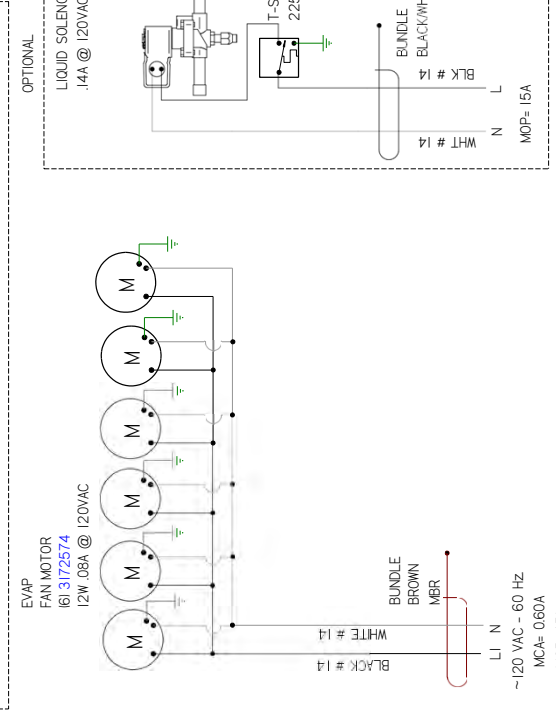

OPTIONAL

HUSSMANN
DIAGRAM-03-SS-12R

MATERIAL - N/A
DATE DRAWN - 9-7-16
DRAWN BY - CRAIG BOOREY
REVIEWED BY - CRAIG BOOREY
APPROVED BY - CRAIG BOOREY
UNLESS OTHERWISE SPECIFIED DIMENSIONS ARE IN INCHES
TOLERANCES ARE:
FIRST DECIMALS .XX ±0.03 .XXX
ANGLES ± 2°
E
PROJECTION

ECN-CAP-0003962
REF -
SHEET 02 OF 1
THIRD
THIRD

3014529 | C

NOTES:
CASE MUST BE GROUNDED
WHEN PASSING WIRES THROUGH METAL HOLES A GROMMET MUST BE USED

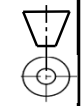

CIRCUIT #1 LOADING	120V	150V	200V

LIGHT CIRCUIT= 0.13A 14.5W
 OPTIONAL SHELF LIGHTS
 2 LED LIGHT - NUA
 2 LED LIGHT - NUA
 2 LED LIGHT - NUA
 CANOPY LIGHTS
 2 LED LIGHT - NUA

REV	ECN	DATE	REVISION DESCRIPTION	REV BY	CHKD BY	APPR BY
A	ECN-CAP-0003982	2016/09/07	RELEASED TO PRODUCTION	CB	CB	CB
B	ECN-COD-0014484	2021/11/22	NEW LIGHTS	AL	CB	CB
C	ECN-COD-0018447	2023/09/21	CHANGED FANS & LIGHTS	CB	CB	CB

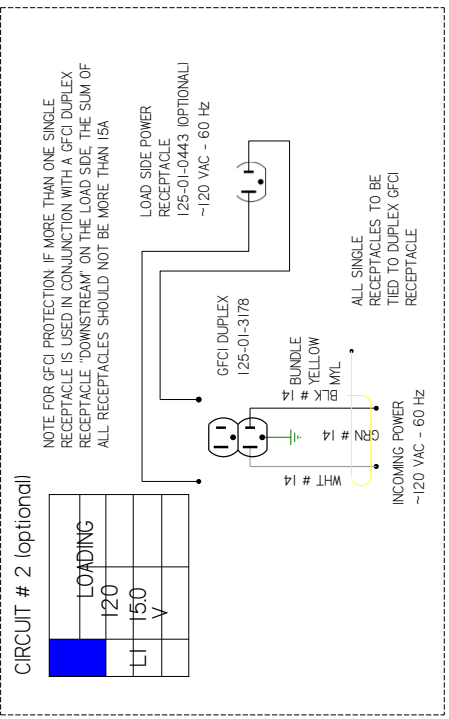

NOTE FOR GFCI PROTECTION: IF MORE THAN ONE SINGLE RECEPTACLE IS USED IN CONJUNCTION WITH A GFCI DUPLEX RECEPTACLE "DOWNSTREAM" ON THE LOAD SIDE, THE SUM OF ALL RECEPTACLES SHOULD NOT BE MORE THAN 15A

ALL SINGLE RECEPTACLES TO BE TIED TO DUPLEX GFCI RECEPTACLE

LOAD SIDE POWER RECEPTACLE 125-01-0443 (OPTIONAL) ~120 VAC - 60 Hz

GFCI DUPLEX 125-01-3178

BUNDLE YELLOW WHT # 14 BLK # 14 MTL

INCOMING POWER ~120 VAC - 60 Hz

OPTIONAL LIQUID SOLENOID .14A @ 120VAC

OPTIONAL T-STAT 228-01-0707

BUNDLE BLACK/WHITE BLK # 14 WHT # 14

N MOP= 15A

EVAP FAN MOTOR 3172574 12W 0.8A @ 120VAC

BUNDLE BROWN MBR

WHITE # 14

BLACK # 14

LI N

~120 VAC - 60 Hz

MCA= 0.10A MOP= 15A

SWITCH TOGGLE 125-01-0307

BUNDLE ORANGE MO

WHITE # 14

BLK # 14

LI N

~120 VAC - 60 Hz

MCA= 0.17A MOP= 15A

LED DRIVER

RED + BK/BL -

2 LED LIGHT - NUA

2 LED LIGHT - NUA

2 LED LIGHT - NUA

MATERIAL - N/A

DATE DRAWN - 9-7-16

DRAWN BY - CRAIG BOOREY

REVIEWED BY - CRAIG BOOREY

APPROVED BY - CRAIG BOOREY

UNLESS OTHERWISE SPECIFIED DIMENSIONS ARE IN INCHES

TOLERANCES ARE:

DECIMALS .XX +0.3 .XXX

ANGLES ± 2°

PROJECTION

ANGU E

3014530 | C

HUSSMANN

DIAGRAM-Q3-SS-

22.5 IS

ECN-CAP-0003982

REF -

SHEET 1 OF 1

THIRD

THIRD

THIRD

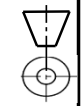

NOTES:
 CASE MUST BE GROUNDED
 WHEN PASSING WIRES THROUGH METAL HOLES A GROMMET MUST BE USED

CIRCUIT #1				
LOADING				
120V				
150V				

LIGHT CIRCUIT= 0.21A 225W

OPTIONAL SHELF LIGHTS
3 LED LIGHT - NUA

CANOPY LIGHTS
3 LED LIGHT - NUA

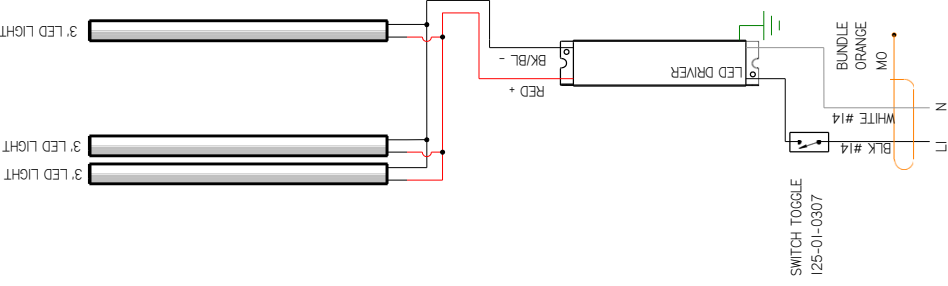

~120 VAC - 60 Hz
MCA= 0.26A
MOP= 15A

REV	ECN	DATE	REVISION DESCRIPTION	REV BY	CHKD BY	APPR BY
A	ECN-CAP-0003962	2016/09/07	RELEASED TO PRODUCTION	CB	CB	CB
B	ECN-COD-0014484	2022/11/22	NEW LIGHTS	AL	CB	CB
C	ECN-COD-0018447	2023/09/21	CHANGED FANS & LIGHTS	CB	CB	CB

CIRCUIT # 2 (optional)

LOADING			
120			
150			
V			

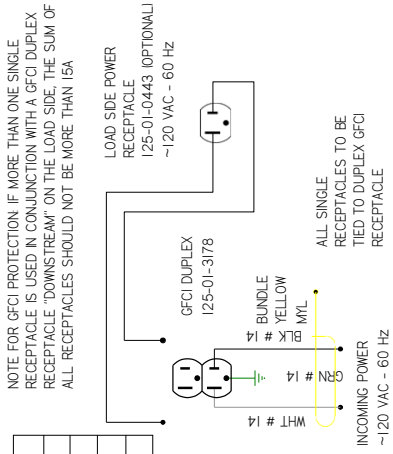

NOTE FOR GFCI PROTECTION IF MORE THAN ONE SINGLE RECEPTACLE IS USED IN CONJUNCTION WITH A GFCI DUPLEX RECEPTACLE "DOWNSTREAM" ON THE LOAD SIDE, THE SUM OF ALL RECEPTACLES SHOULD NOT BE MORE THAN 15A

ALL SINGLE RECEPTACLES TO BE TIED TO DUPLEX GFCI RECEPTACLE

EVAF
FAN MOTOR
I21 3172574
12W .08A @ 120VAC

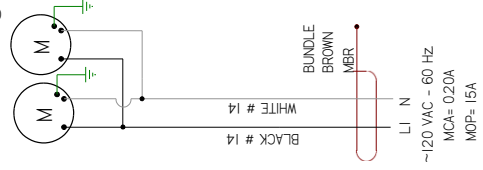

~120 VAC - 60 Hz
MCA= 0.20A
MOP= 15A

HUSSMANN
DIAGRAM-Q3-SS-22.5 OS

MATERIAL - N/A
DATE DRAWN - 9-7-16
DRAWN BY - CRAIG BOOREY
REVIEWED BY - CRAIG BOOREY
APPROVED BY - CRAIG BOOREY
UNLESS OTHERWISE SPECIFIED DIMENSIONS ARE IN INCHES
TOLERANCES ARE:
DIMENSIONS .XX +.03 .XXX
+0.0
ANGLES ± 2°

ECN-CAP-0003962
REF -
SHEET 1 OF 1
THIRD PROJECTION

3014531 | C

NOTES:
CASE MUST BE GROUNDED
WHEN PASSING WIRES THROUGH METAL HOLES A GROMMET MUST BE USED

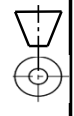

CIRCUIT #1 LOADING	120V	150V	208V

LIGHT CIRCUIT= 0.21A 226W

OPTIONAL SHELF
LIGHTS

CANOPY
LIGHTS

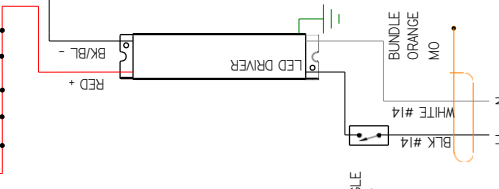
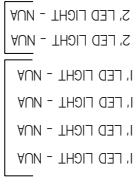

~120 VAC - 60 HZ
MCA= 0.26A
MOP= 15A

REV	ECN	DATE	REVISION DESCRIPTION	REV BY	CHKD BY	APPR BY
A	ECN-000-0003962	2016/09/07	RELEASED TO PRODUCTION	CB	CB	CB
B	ECN-000-0014484	2021/11/22	NEW LIGHTS	AL	CB	CB
C	ECN-000-0018447	2023/09/23	CHANGED FANS & LIGHTS	CB	CB	CB

CIRCUIT # 2 optional

LOADING	120V	150V	208V

NOTE FOR GFCI PROTECTION IF MORE THAN ONE SINGLE RECEPTACLE IS USED IN CONJUNCTION WITH A GFCI DUPLEX RECEPTACLE "DOWNSTREAM" ON THE LOAD SIDE THE SUM OF ALL RECEPTACLES SHOULD NOT BE MORE THAN 15A

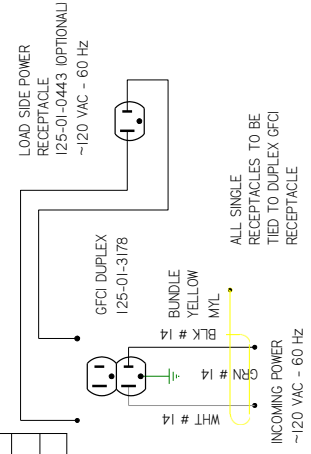

EVAP
FAN MOTOR
3172574
12W 08A @ 120VAC

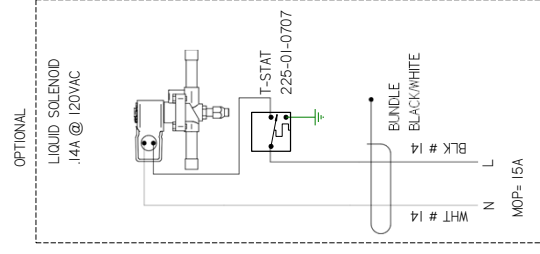
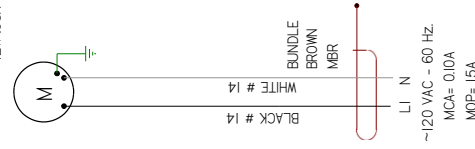

MATERIAL - N/A

DATE DRAWN - 9-7-16

DRAWN BY - CRAIG BOOREY

APPROVED BY - CRAIG BOOREY

UNLESS OTHERWISE SPECIFIED DIMENSIONS ARE IN INCHES
TOLERANCES ARE:

DECIMALS .XX +03 .XXX
+0.0

ANGLES ± 2°

HUSSMANN
DIAGRAM-Q3-SS-
45 IS

3014532 | C

ECN-CAP-0003962
REF -
SHEET 1 OF 1
THIRD
ANGU
E
PROJECTION



CIRCUIT #1 LOADING	120V	150V	180V
■	■	■	■

LIGHT CIRCUIT= 0.14A 158W

OPTIONAL SHELF CANOPY LIGHTS

T LED LIGHT - NUA

T LED LIGHT - NUA

T LED LIGHT - NUA

T LED LIGHT - NUA

T LED LIGHT - NUA

T LED LIGHT - NUA

REV	ECN	DATE	REVISION DESCRIPTION	REV BY	CHKD BY	APPR BY
A	ECN-CAP-0003982	2016/09/07	RELEASED TO PRODUCTION	CB	CB	CB
B	ECN-COD-0014484	2021/11/22	NEW LIGHTS	AL	CB	CB
C	ECN-COD-0018447	2023/09/21	CHANGED FANS & LIGHTS	CB	CB	CB
D	ECN-COD-0018716	2023/11/02	NEW FAN MOTORS	CB	CB	CB

CIRCUIT # 2 (optional)

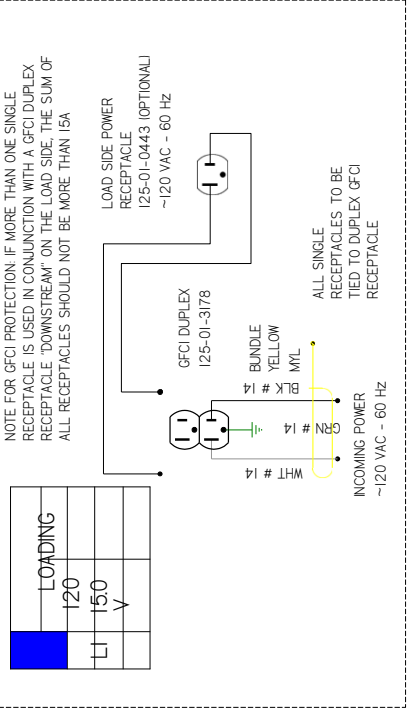

OPTIONAL

LIQUID SOLENOID .14A @ 120VAC

I-STAT 225-01-0707

BUNDLE BLACK/WHITE

BLK # 14

WHT # 14

N

MOP= 15A

OPTIONAL

EVAP FAN MOTOR I31 3172574 12W .08A @ 120VAC

BUNDLE BROWN MBR

WHITE # 14

BLACK # 14

LI N

MCA= 0.30A

MOP= 15A

OPTIONAL

SWITCH TOGGLE 125-01-0307

BUNDLE ORANGE MO

WHITE # 14

BLK # 14

LI N

MCA= 0.18A

MOP= 15A

HUSSMANN
DIAGRAM-Q3-SS-
90 OS

MATERIAL - N/A
DATE DRAWN - 9-7-16
DRAWN BY - CRAIG BOOREY
REVIEWED BY - CRAIG BOOREY
APPROVED BY - CRAIG BOOREY
UNLESS OTHERWISE SPECIFIED DIMENSIONS ARE IN INCHES
TOLERANCES ARE:
FRACTIONS .XX
DECIMALS .XX +03 .XXX
ANGLES ± 2°

ECN-CAP-0003982
REF -
SHEET 06 OF 10
DIMENSIONS ARE IN INCHES
THRU
ANGU
E
PROJECTION

3014534 | D

NOTES:
CASE MUST BE GROUNDED
WHEN PASSING WIRES THROUGH METAL HOLES A GROMMET MUST BE USED

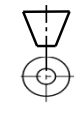

REVISION HISTORY			
REV	ECN	DATE	REVISION DESCRIPTION
B	ECN-C00-0015612	3-30-22	NEW LIGHTS
C	ECN-C00-001844A	9-22-23	CHANGED FANS & LIGHTS

CIRCUIT #1	LOADING
120V	
140V	
160V	

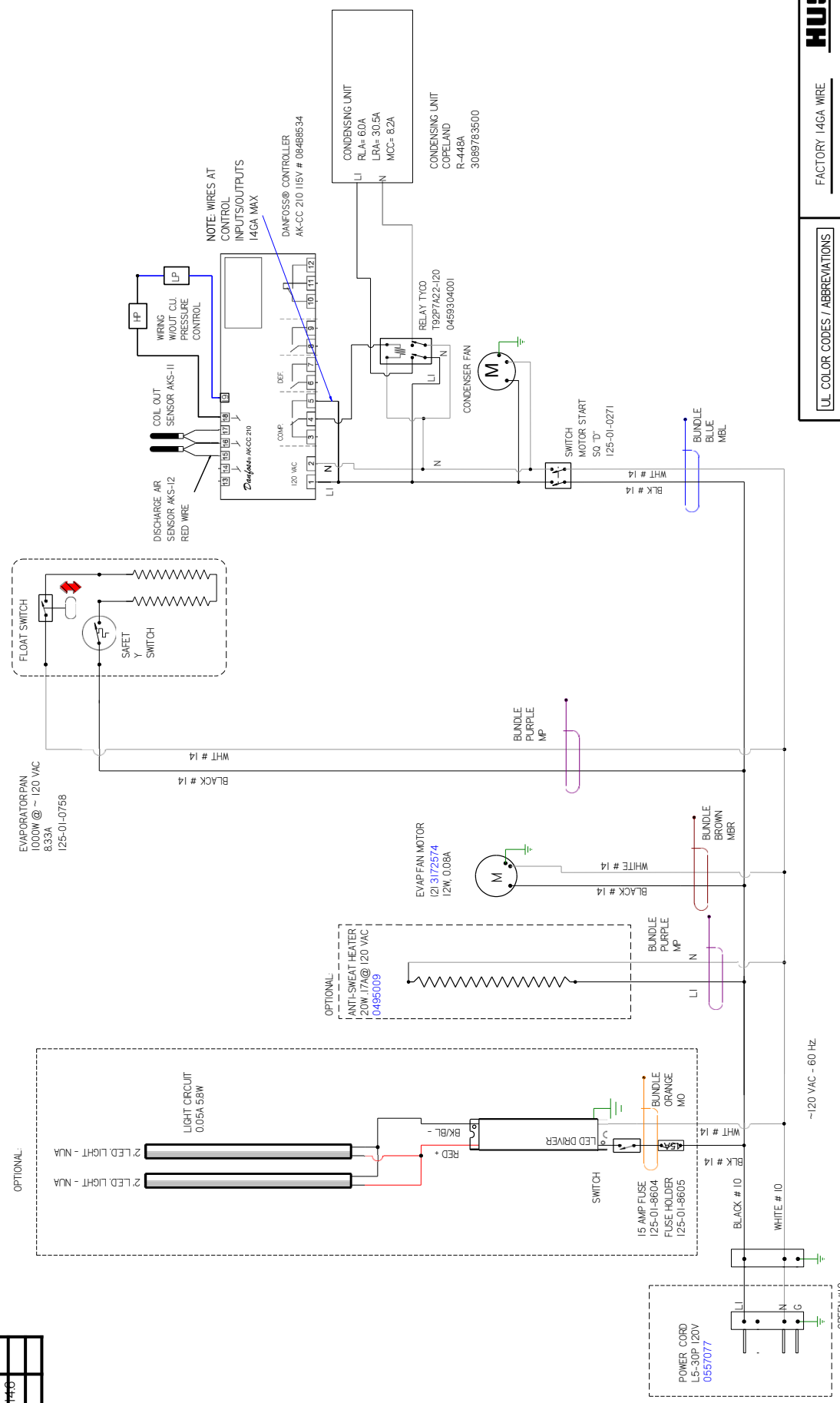

HUSSMANN®
DIAGRAM-Q3-SS-2S

FACTORY 14GA WIRE
 _FACTORY LOGA WIRE
 _ _ _ _ _ FIELD WIRE
 DO NOT SCALE DRAWING
 SHEET 1 OF 1

UL COLOR CODES / ABBREVIATIONS	
RED = RD	WHITE = WT
BLACK = BK	GREEN = GN
BLUE = BL	BROWN = BN
YELLOW = YL	ORANGE = OR
GRAY = GR	OR VIOLET = VT

NOTES:
 1. PRINTED DOCUMENT REQUIRED SETTING: ALL COLORS BLACK & WHITE.
 2. CASE & ANY REMOVABLE PANEL WITH ELECTRICAL PARTS MUST BE GROUNDED.
 3. WHEN PASSING WIRES THROUGH METAL HOLES A GROMMET MUST BE USED

CIRCUIT #1				
LOADING				
120V				
208V				

REVISION HISTORY				
REV	ECN	DATE	REVISION DESCRIPTION	REV BY (CHKD BY) APPR BY
B	ECN-C00-0015612	3-30-22	NEW LIGHTS	AL CB CB
C	ECN-C00-0018448	9-22-23	CHANGED FANS & LIGHTS	CB CB CB

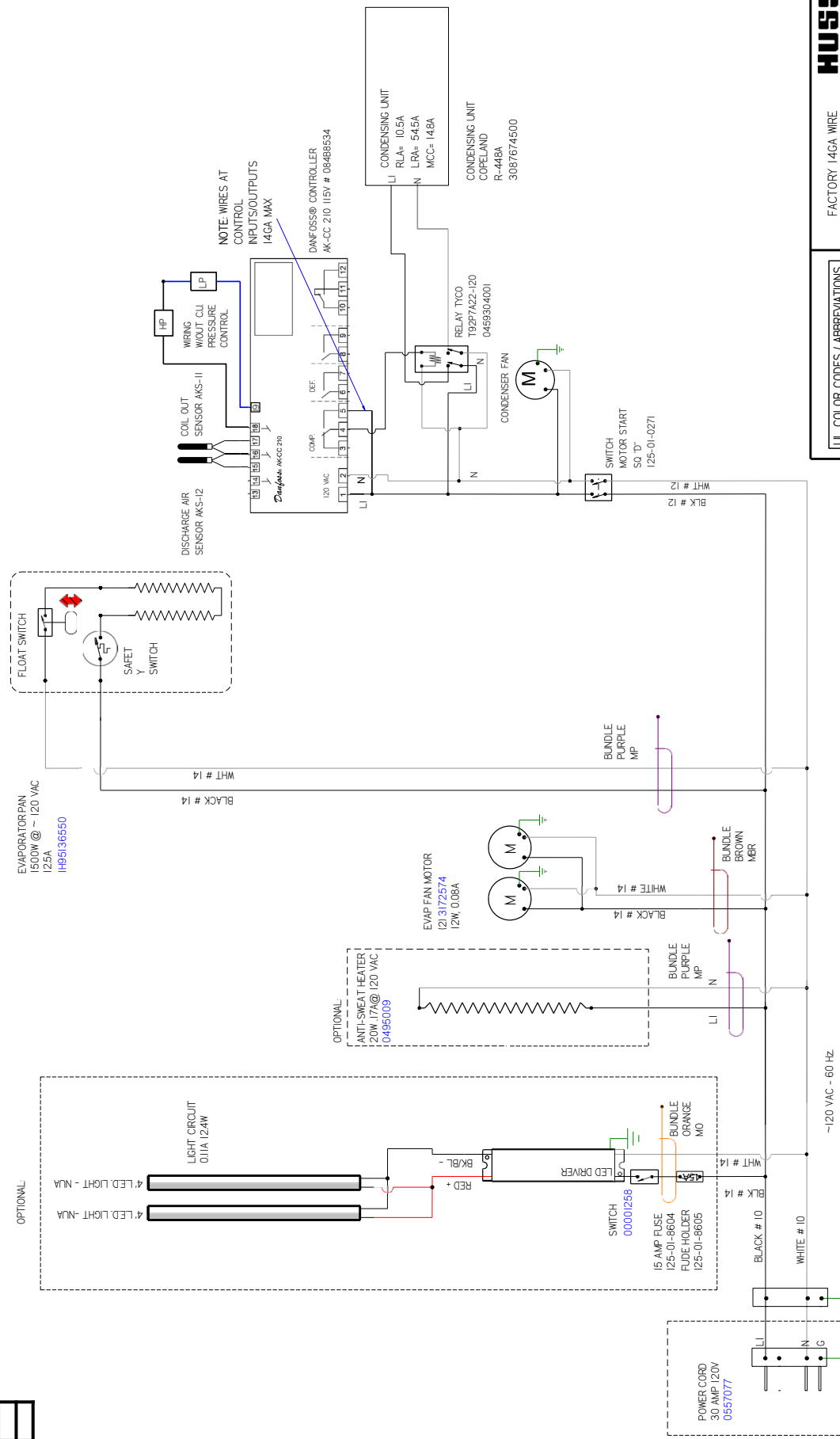

- NOTES:
1. PRINTED DOCUMENT REQUIRED SETTING: ALL COLORS BLACK & WHITE.
 2. CASE & ANY REMOVABLE PANEL WITH ELECTRICAL PARTS MUST BE GROUNDED.
 3. WHEN PASSING WIRES THROUGH METAL HOLES A GROMMET MUST BE USED

HUSSMANN
DIAGRAM-Q3-SS-4S
 DO NOT SCALE DRAWING
 SHEET 1 OF 1

UL COLOR CODES / ABBREVIATIONS

- WHITE = WT
- GREEN = GN
- BROWN = BN
- ORANGE = OR
- OR VIOLET = VT
- GRAY = GR
- RED = RD
- BLACK = BK
- BLUE = BL
- YELLOW = YL

FACTORY 14GA WIRE
 _FACTORY LOGA WIRE
 _FIELD WIRE
 _

REV	ECN	DATE	REVISION DESCRIPTION	REV BY	CHKD BY	APPR BY
C	ECN-COD-0018448	9-22-23	CHANGED FANS & LIGHTS	CB	CB	CB
D	FEN-COD-0018716	11-2-23	NEW FAN MOTORS	CB	CB	CB

CIRCUIT #1	LOADING
200V	240
150V	150
100V	100

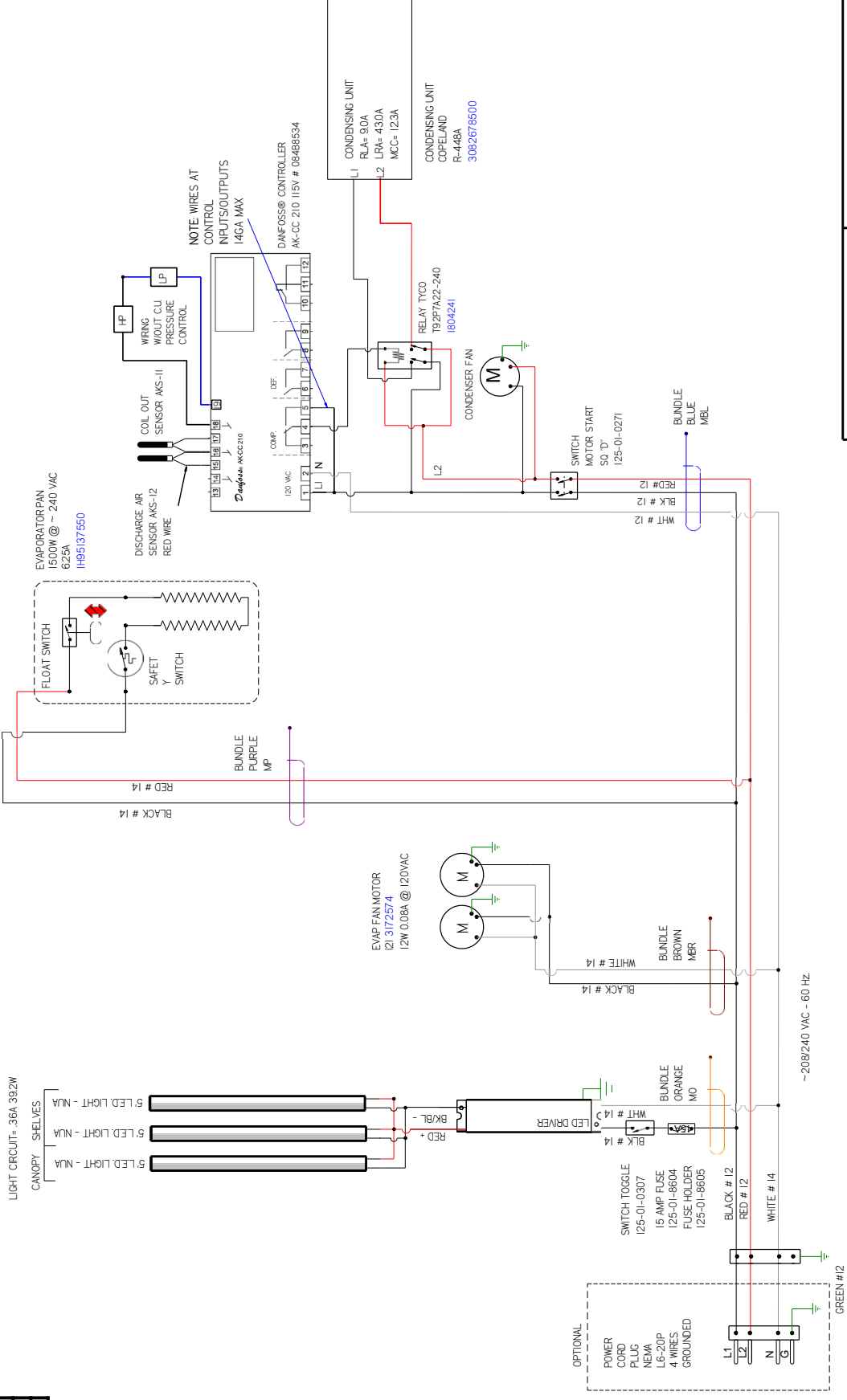

- NOTES:**
1. PRINTED DOCUMENT REQUIRED SETTING: ALL COLORS BLACK & WHITE
 2. CASE & ANY REMOVABLE PANEL WITH ELECTRICAL PARTS MUST BE GROUNDED.
 3. WHEN PASSING WIRES THROUGH METAL HOLES A GROMMET MUST BE USED

HUSSMANN
DIAGRAM-Q3-SS-5S
 DO NOT SCALE DRAWING
 SHEET 1 OF 1

3125636
 D

#	LOADING
208	240 V
L1	13.9
L2	13.3

NOTE: CASE MUST BE GROUNDED

REVISION HISTORY						
REV	ECN	DATE	REVISION DESCRIPTION	REV BY	CHKD BY	APPR BY
B	ECN-C00-0015612	3-30-22	NEW LIGHTS	AL	CB	CB
C	ECN-C00-0018448	9-22-23	CHANGED FANS & LIGHTS	CB	CB	CB

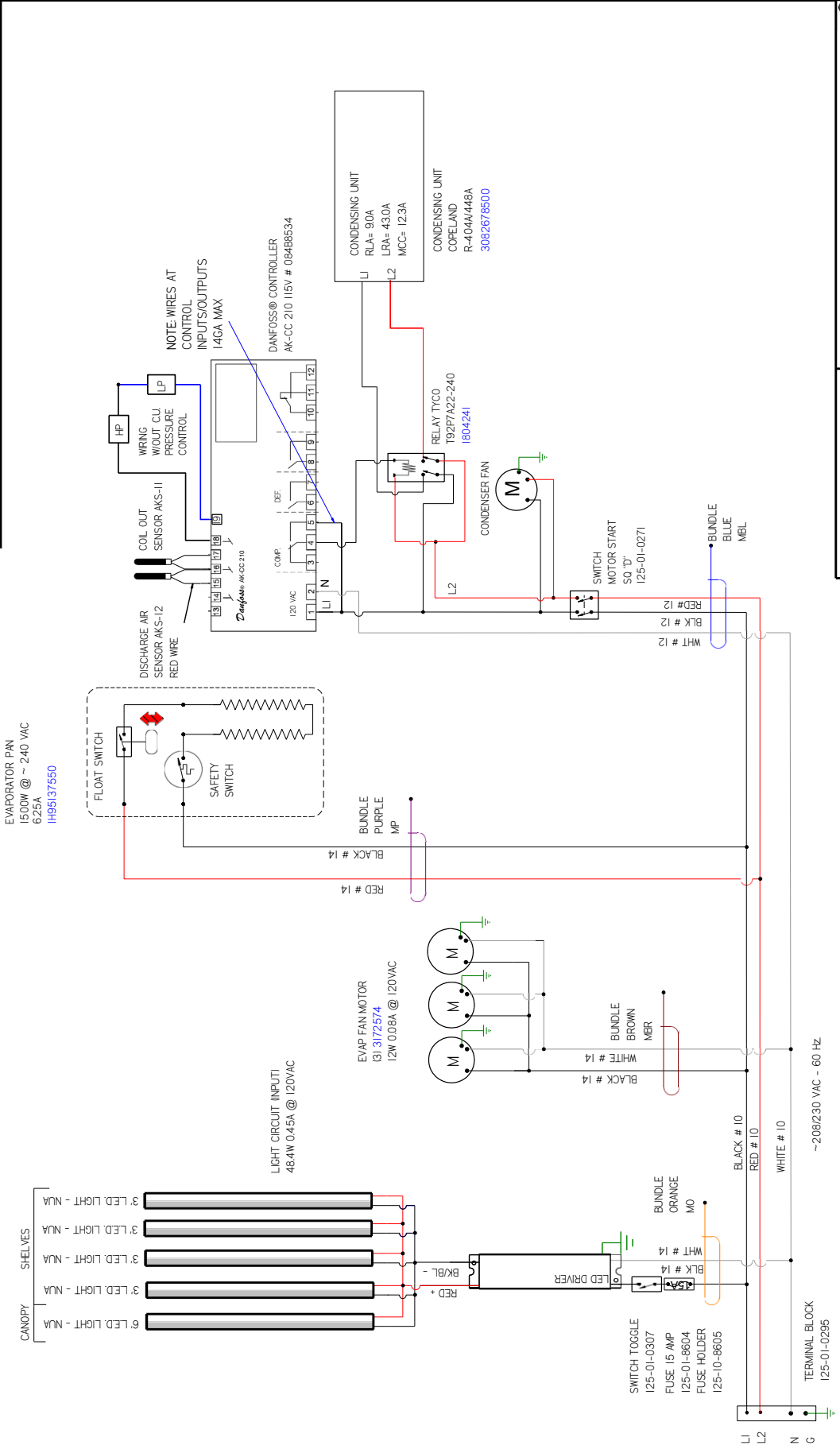

- NOTES:
1. PRINTED DOCUMENT REQUIRED SETTING: ALL COLORS BLACK & WHITE
 2. CASE & ANY REMOVABLE PANEL WITH ELECTRICAL PARTS MUST BE GROUNDED.
 3. WHEN PASSING WIRES THROUGH METAL HOLES A GROMMET MUST BE USED

REVISION HISTORY			
REV	ECN	DATE	REVISION DESCRIPTION
B	ECN-C00-0015612	3-31-22	NEW LIGHTS
C	ECN-C00-001844A	9-22-23	CHANGED FANS & LIGHTS

CIRCUIT #1	LOADING
240V	240
143V	100
135V	100

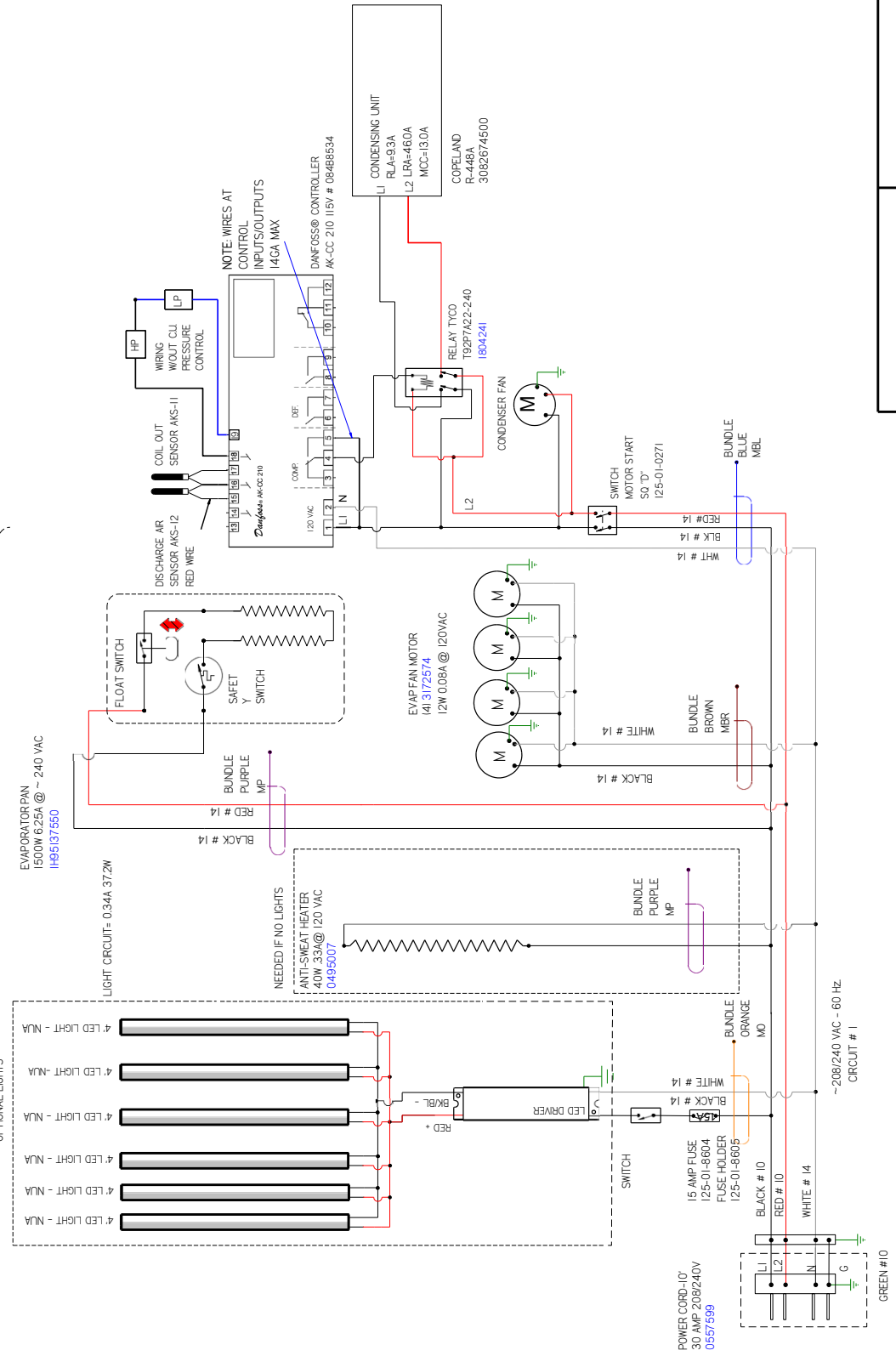

- NOTES:**
1. PRINTED DOCUMENT REQUIRED SETTING: ALL COLORS BLACK & WHITE
 2. CASE & ANY REMOVABLE PANEL WITH ELECTRICAL PARTS MUST BE GROUNDED.
 3. WHEN PASSING WIRES THROUGH METAL HOLES A GROMMET MUST BE USED

HUSSMANN
DIAGRAM-Q3-SS-8S

FACTORY 14GA WIRE
 _FACTORY LOGGA WIRE
 _FIELD WIRE
 _DO NOT SCALE DRAWING

UL COLOR CODES / ABBREVIATIONS
 RED = RD
 BLACK = BK
 BLUE = BL
 YELLOW = YL
 GRAY = GR
 WHITE = WT
 GREEN = GN
 BROWN = BN
 ORANGE = OR
 VIOLET = VT

SHEET 1 OF 1

3125638

CIRCUIT #1
LOADING

120V	
208V	
240V	

REVISION HISTORY			
REV	ECN	DATE	REVISION DESCRIPTION
B	ECN-COD-0014506	10-21-21	LABELLED COIL OUT SENSOR
C	ECN-COD-0015256	3-4-22	NEW LIGHTS
D	ECN-COD-0018448	9-25-23	CHANGED FANS & LIGHTS

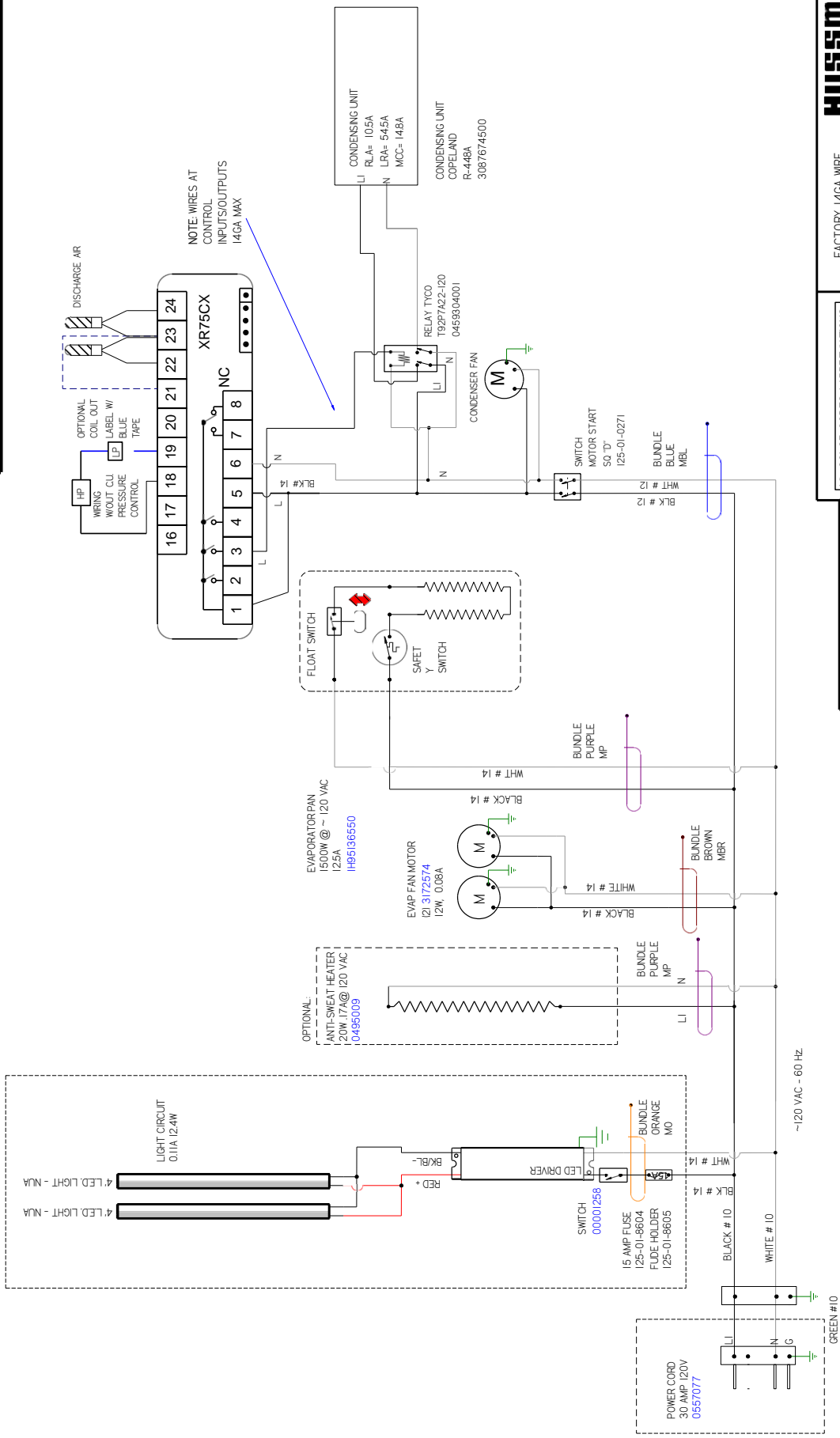

NOTE: WIRES AT CONTROL INPUTS/OUTPUTS 14GA MAX

HUSSMANN
DIAGRAM-Q3-SS-4S WXR75 CTRL
3156674

FACTORY 14GA WIRE
 _FACTORY 10GA WIRE
 _ _FIELD WIRE
 _ _ _ _ _DO NOT SCALE DRAWING

UL COLOR CODES / ABBREVIATIONS:
 RED = RD
 BLACK = BK
 BLUE = BL
 BROWN = BR
 DARK BLUE = DBL
 MDB GREEN = MG
 LIGHT BLUE = LBL
 MAROON = MR
 MMR ORANGE = MO
 MOPINK = MPI
 PURPLE = MP
 RED = MR
 YELLOW = MYL

WIRE MARKER COLORS/ABBREVIATIONS:
 MAROON = MR
 MMR ORANGE = MO
 MOPINK = MPI
 PURPLE = MP
 RED = MR
 YELLOW = MYL

UL COLOR CODES / ABBREVIATIONS:
 WHITE = WT
 GREEN = GN
 BROWN = BN
 ORANGE = OR
 YELLOW = YL
 GRAY = GR
 VIOLET = VT

DO NOT SCALE DRAWING
 SHEET 1 OF 1

- NOTES:
1. PRINTED DOCUMENT REQUIRED SETTING. ALL COLORS BLACK & WHITE
 2. CASE & ANY REMOVABLE PANEL WITH ELECTRICAL PARTS MUST BE GROUNDED.
 3. WHEN PASSING WIRES THROUGH METAL HOLES A GROMMET MUST BE USED

CIRCUIT # 1

LOADING	208	240 V
L1	13.9	16.1
L2	13.2	15.3

NOTE: CASE MUST BE GROUNDED

REV	ECN	DATE	REVISION DESCRIPTION	REV BY	CHKD BY	APPR BY
D	ECN-COD-0016096	6-23-22	CHANGED RELAY	CB	CB	CB
E	ECN-COD-0018444	9-25-23	CHANGED FANS & LIGHTS	CB	CB	CB

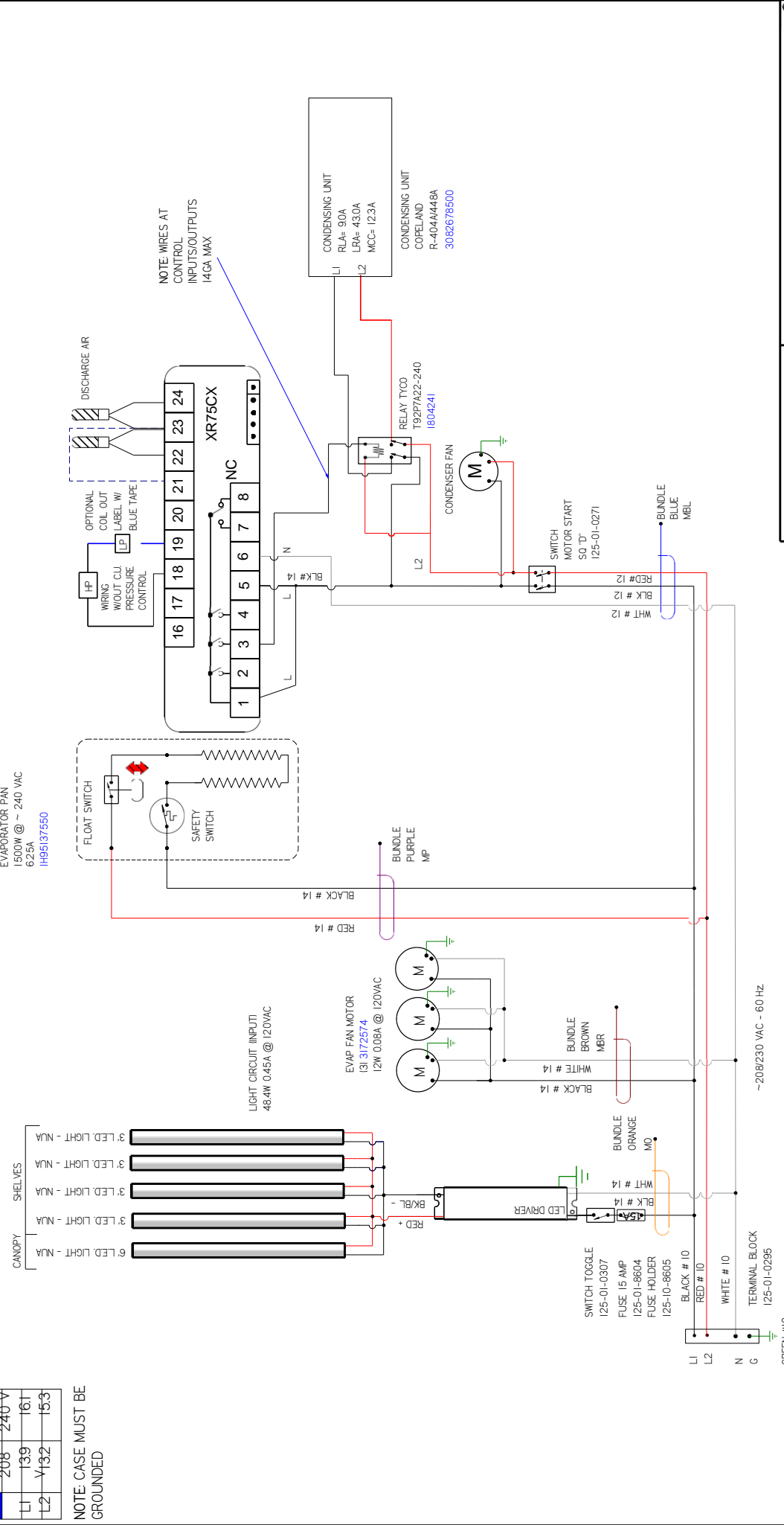

HUSSMANN

DIAGRAM-Q3-SS-6S WXR75 CTRL

3157153

FACTORY 14GA WIRE

FACTORY LOGGA WIRE

FIELD WIRE

DO NOT SCALE DRAWING

SHEET 1 OF 1

UL COLOR CODES / ABBREVIATIONS

RED = RD	WHITE = WT
BLACK = BK	GREEN = GN
BLUE = BL	BROWN = BN
YELLOW = YL	ORANGE = OR
GRAY = GR	OR VIOLET = OV

WIRE MARKER COLORS/ABBREVIATIONS

BLACK = MBK	MAROON = MR
BLUE = MBL	MMR ORANGE = MO
BROWN = MBR	MO PINK = MPI
DARK BLUE = MBDB	PURPLE = MP
MDB GREEN = MDBG	RED = MR
LIGHT BLUE = MBL	YELLOW = MYL

NOTES:

1. PRINTED DOCUMENT REQUIRED SETTING: ALL COLORS BLACK & WHITE
2. CASE & ANY REMOVABLE PANEL WITH ELECTRICAL PARTS MUST BE GROUNDED.
3. WHEN PASSING WIRES THROUGH METAL HOLES A GROMMET MUST BE USED

REV	ECN	DATE	REVISION DESCRIPTION	REV BY	CHKD BY	APPR BY
D	ECN-COD-00160893	6-7-22	REVISED RELAY WIRING	CB	CB	CB
E	ECN-COD-00160898	6-23-22	CHANGED RELAY	CB	CB	CB
F	ECN-COD-00184448	9-26-23	CHANGED FANS & LIGHTS	CB	CB	CB

CIRCUIT #1
LOADING

Z08V	Z4U
L143	100
L195	100

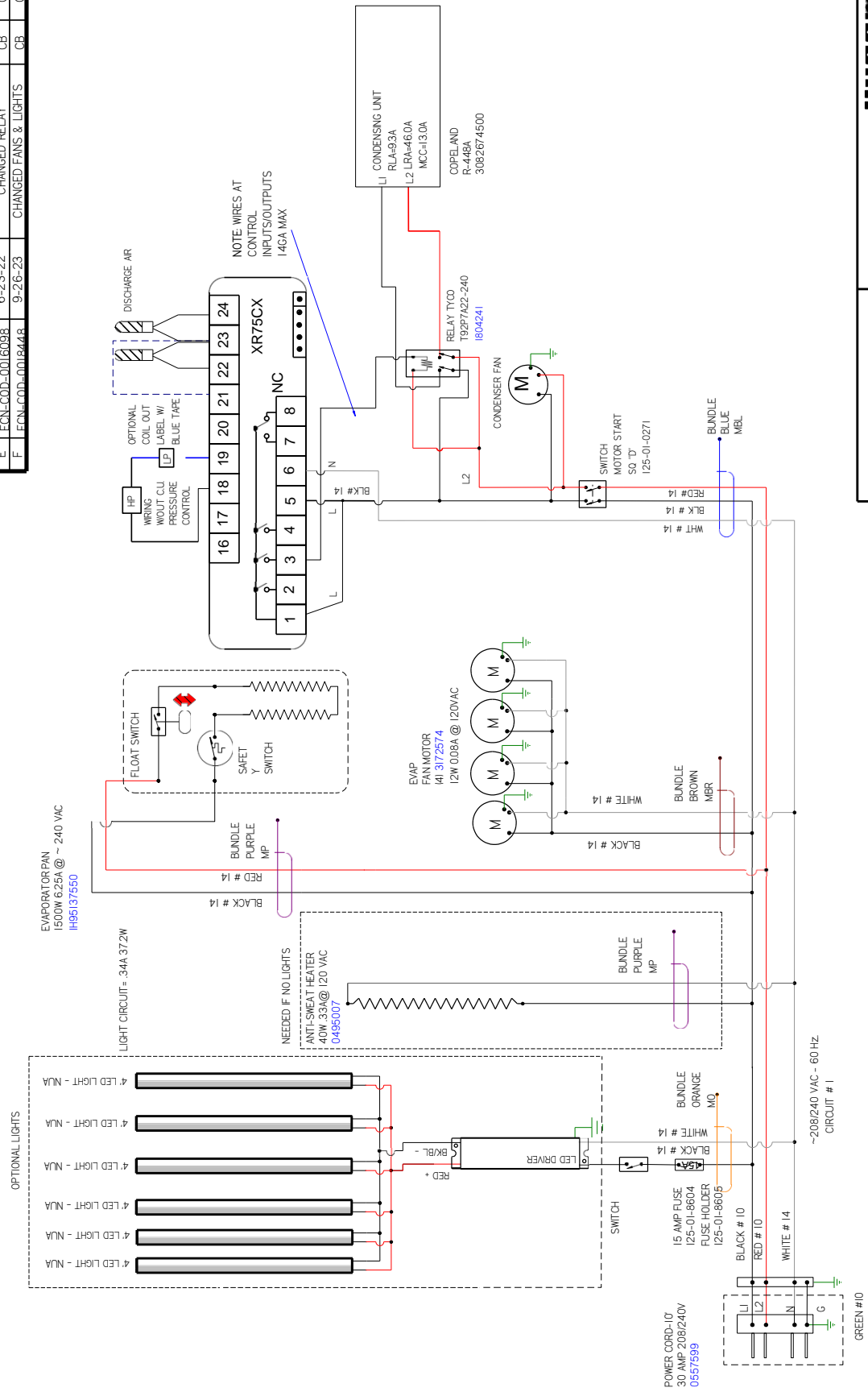

UL COLOR CODES / ABBREVIATIONS	
RED = RD	WHITE = WT
BLACK = BK	GREEN = GN
BLUE = BL	BROWN = BN
YELLOW = YL	ORANGE = OR
GRAY = GR	OR VIOLET = VT

WIRE MARKER COLORS/ABBREVIATIONS	
MAROON = MBK	MAR ORANGE = MO
BLACK = MBL	PINK = MPI
BROWN = MBR	PURPLE = MP
DARK BLUE = MDB	GREEN = MG
LIGHT BLUE = MBL	YELLOW = MYL

- NOTES:
1. PRINTED DOCUMENT REQUIRED SETTING: ALL COLORS BLACK & WHITE
 2. CASE & ANY REMOVABLE PANEL WITH ELECTRICAL PARTS MUST BE GROUNDED.
 3. WHEN PASSING WIRES THROUGH METAL HOLES A GROMMET MUST BE USED

HUSSMANN
DIAGRAM-Q3-SS-8-
S WXR75 CTLR

3156422
 SHEET 1 OF 1

FACTORY 14GA WIRE
 _FACTORY LOGA WIRE
 _FIELD WIRE
 DO NOT SCALE DRAWING

REVISION HISTORY			
REV	EN	DATE	DESCRIPTION
A	ECN-CAP-0008237	2011/06/08	RELEASED TO PRODUCTION
B	ECN-CAP-0014599	2008/09/02	REMOVED C.U.I. MODEL NUMBER
C	ECN-CAP-0016604	2010/04/16	CHANGED POWER CORD

CIRCUIT #1	LOADING
120V	
110V	

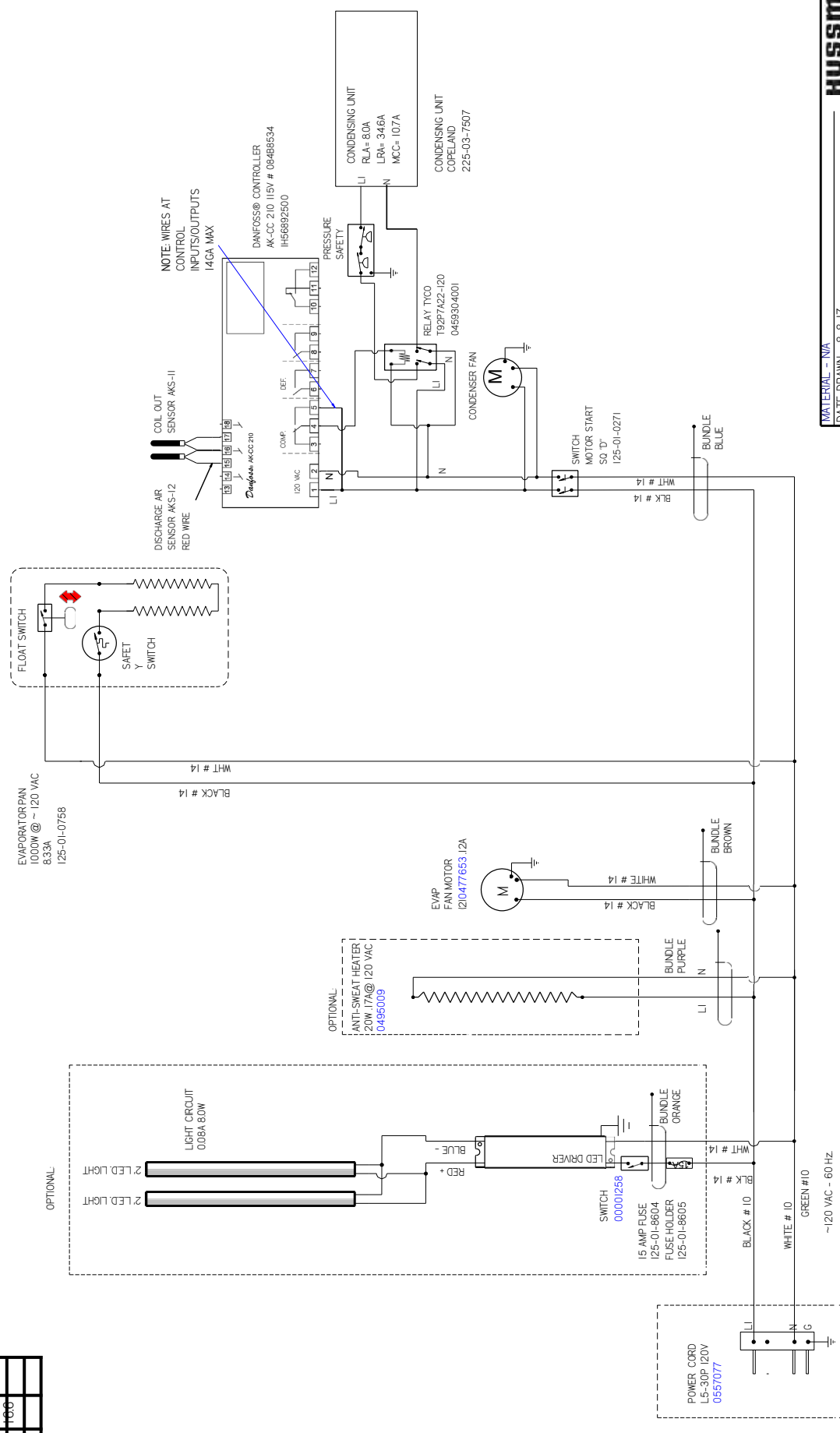

MATERIAL - N/A
 DATE DRAWN - 8-8-17
 DRAWN BY - CRAIG BOOREY
 REVIEWED BY - CRAIG BOOREY
 APPROVED BY - CRAIG BOOREY
 UNLESS OTHERWISE SPECIFIED DIMENSIONS ARE IN INCHES
 TOLERANCES ARE:
 DECIMALS .XX +0.3 .XXX
 ANGLES ± 2°
 PROJECTION

HUSMANN
 DIAGRAM-03-SS-2S

3041417 | C

NOTES:
 CASE MUST BE GROUNDED
 WHEN PASSING WIRES THROUGH METAL HOLES A GROMMET MUST BE USED

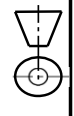

REV	ECN	DATE	REVISION DESCRIPTION	REV BY	CHKD BY	APPR BY
A	ECN-CAP-0008237	2017/08/08	RELEASED TO PRODUCTION	CB	CB	CB
B	ECN-CAP-0005961	2017/11/13	REVISED WIRING	CB	CB	CB
C	ECN-CAP-0014509	2018/09/12	REMOVED CU.I MODEL NUMBER	CB	CB	CB
D	ECN-CAP-0016801	2019/04/05	CHANGED COND UNIT & POWER CORD	CB	CB	CB
E	ECN-COD-0011252	2020/06/02	ADDED PRESSURE CONTROL WIRING	CB	CB	CB

CIRCUIT #1	DWG	120V	1/2" x 1/2"
------------	-----	------	-------------

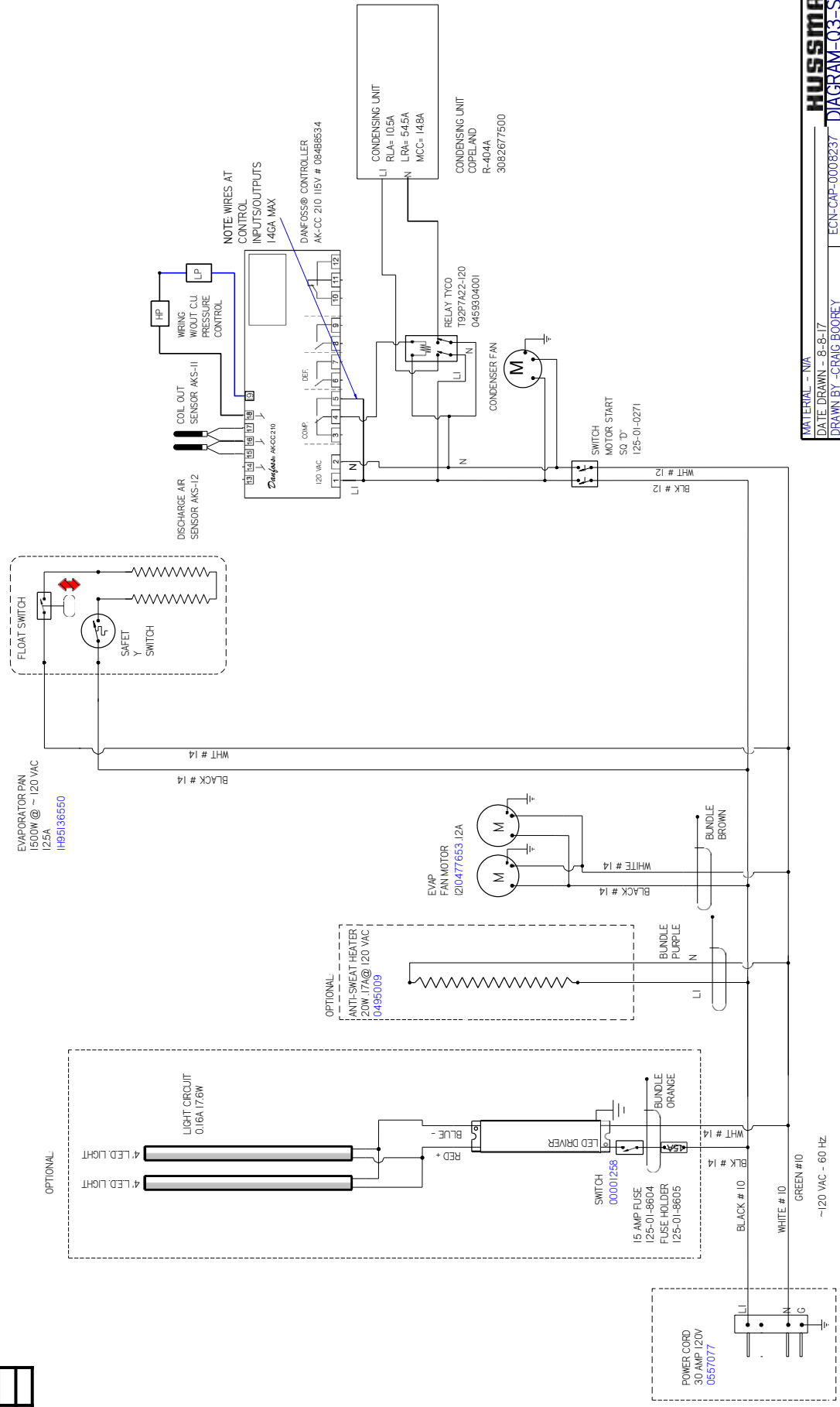

HUSSMANN
DIAGRAM-03-SS-4S

MATERIAL - N/A
 DATE DRAWN - 8-8-17
 DRAWN BY - CRAIG BOOREY
 REVIEWED BY - CRAIG BOOREY
 APPROVED BY - CRAIG BOOREY
 REF -
 ECN-CAP-0008237
 SHEET 1 OF 1
 UNLESS OTHERWISE SPECIFIED DIMENSIONS ARE IN INCHES
 TOLERANCES ARE:
 THIRD ANGLE PROJECTION
 DECIMALS .XX +0.3 .XXX
 ANGLES ± 2°

NOTES:
 CASE MUST BE GROUNDED
 WHEN PASSING WIRES THROUGH METAL HOLES A GROMMET MUST BE USED

REV	ECN	DATE	REVISION DESCRIPTION	REV BY	CHKD BY	APPR BY
A	ECN-CAP-0008237	2011/06/09	RELEASED TO PRODUCTION	CB	CB	CB
B	ECN-CAP-0008273	2008/07/16	REVISED CUJ NOMENCLATURE	CB	CB	CB
C	ECN-CAP-0004659	2008/09/12	REMOVED CUJ MODEL NUMBER	CB	CB	CB
D	ECN-COD-0011235	2020/06/02	ADDED PRESSURE CONTROL WIRING	CB	CB	CB

CIRCUIT #1	LDING	Z06V	Z40

LIGHT CIRCUIT= 27A 306W
CANOPY SHELVES

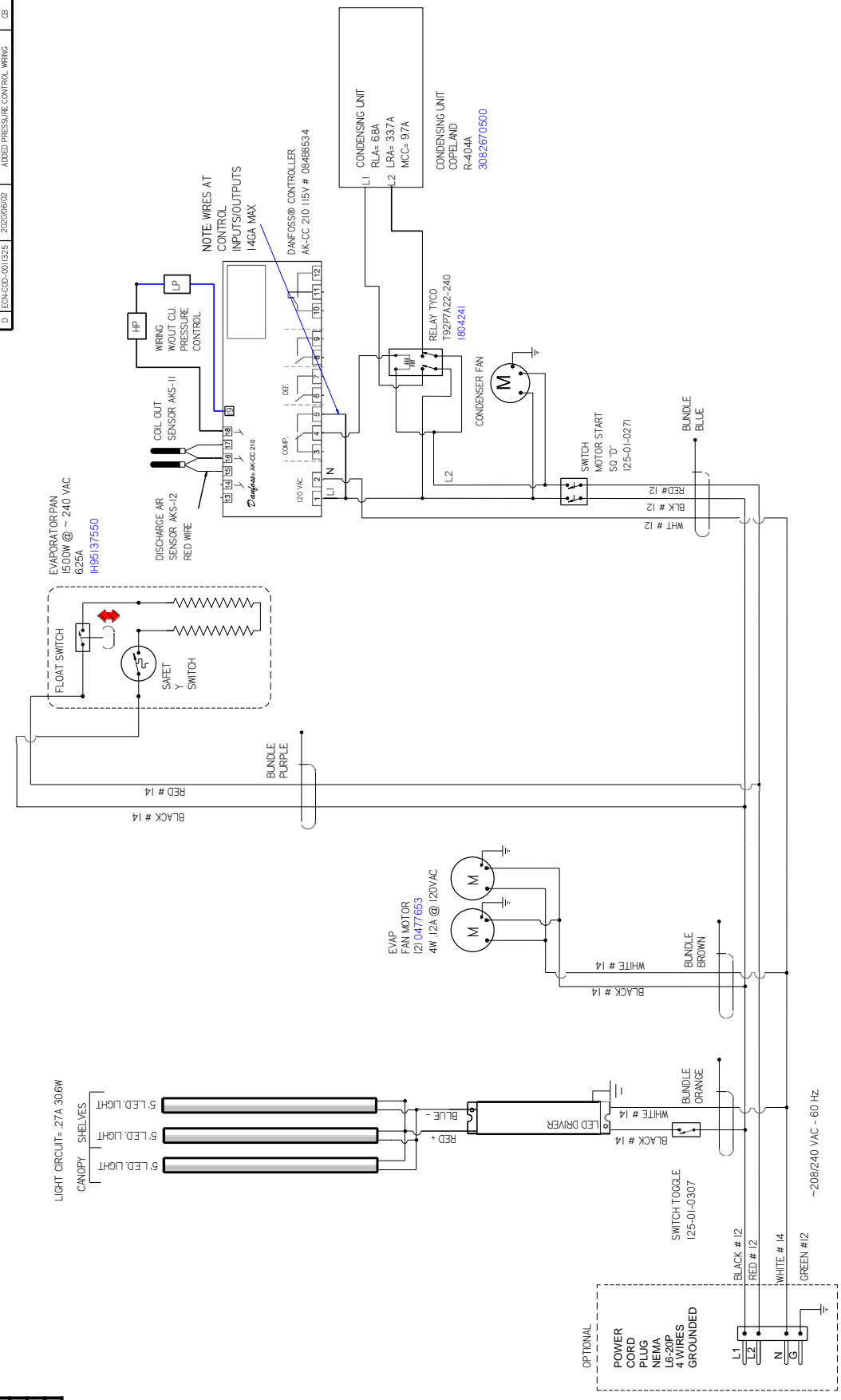

HUSSMANN
DIAGRAM-Q3-SS-5S

MATERIAL - N/A
DATE DRAWN - 8-9-17
DRAWN BY - CRAIG BOOREY
REVIEWED BY - CRAIG BOOREY
APPROVED BY - CRAIG BOOREY
UNLESS OTHERWISE SPECIFIED DIMENSIONS ARE IN INCHES
TOLERANCES ARE:
DECIMALS .XX +0.03 .XXX
+0.0
ANGLES ± 2°
PROJECTION
E
3041421 | D

NOTES:
CASE MUST BE GROUNDED
WHEN PASSING WIRES THROUGH METAL HOLES A GROMMET MUST BE USED

CIRCUIT

#	LOADING
L1	208 - 240 V
L2	138 - 161 132 - 153

NOTE: CASE MUST BE GROUNDED

REV	ECN	DATE	REVISION DESCRIPTION	REV BY	CHK BY	APPR BY
A	ECN-CAP-0008237	2011/06/09	RELEASED TO PRODUCTION	CB	CB	CB
B	ECN-CAP-0014599	2018/09/12	CHANGED CU MODEL NUMBER	CB	CB	CB
C	ECN-CAP-0016801	2019/04/04	CHANGED COND UNIT	CB	CB	CB
D	ECN-CO-0011324	2020/09/22	CHANGED CU WAIT PRESSURE CONTROL	CB	CB	CB

EVAPORATOR PAN
1500W @ ~ 240 VAC
625A
IH95137550

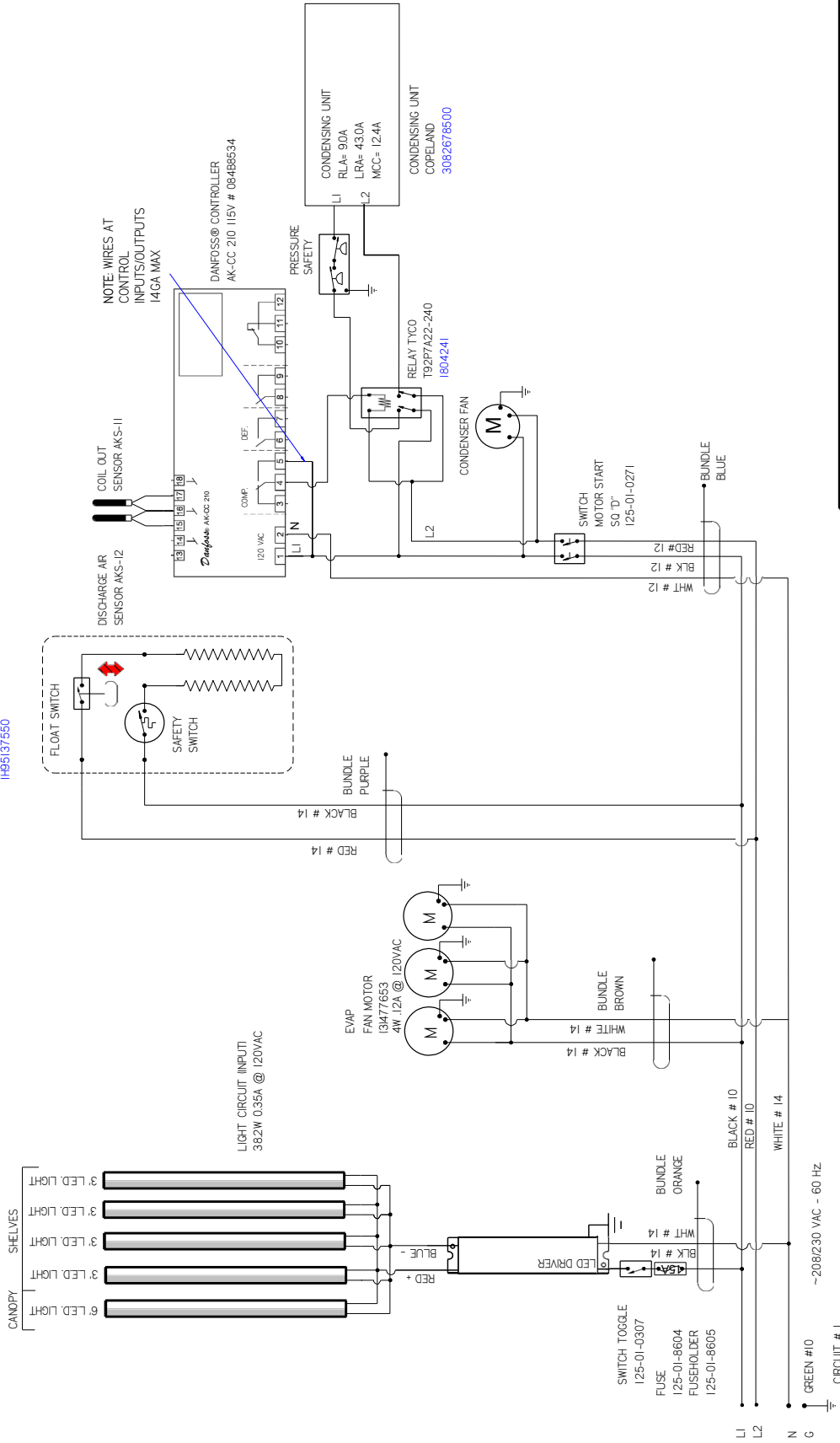

HUSSMANN
DIAGRAM-Q3-SS-6S

MATERIAL - N/A
DATE DRAWN - 8-9-17
DRAWN BY - CRAIG BOOREY
REVIEWED BY - CRAIG BOOREY
APPROVED BY - CRAIG BOOREY
SHEET 1 OF 1
UNLESS OTHERWISE SPECIFIED DIMENSIONS ARE IN INCHES
TOLERANCES ARE:
THIRD ANGLE PROJECTION
DECIMALS .XX +0.3 .XXX
±0.0 ANGLES ± 2°

ECN-CAP-0008237
REF -
SHEET 1 OF 1

3041419 | D

NOTES:
CASE MUST BE GROUNDED
WHEN PASSING WIRES THROUGH METAL HOLES A GROMMET MUST BE USED

REV	ECN	DATE	REVISION DESCRIPTION	REV BY	CHKD BY	APPR BY
A	ECN-CAP-0008237	2017/06/09	RELEASED TO PRODUCTION	CB	CE	CB
B	ECN-CAP-0014599	2018/09/12	REVISED C.U.I MODEL NUMBER	CB	CE	CB
C	ECN-CAP-0016601	2019/04/08	CHANGED COND UNIT & POWER CORD	CB	CE	CB

CIRCUIT #1	LDWG	Z06V	Z40

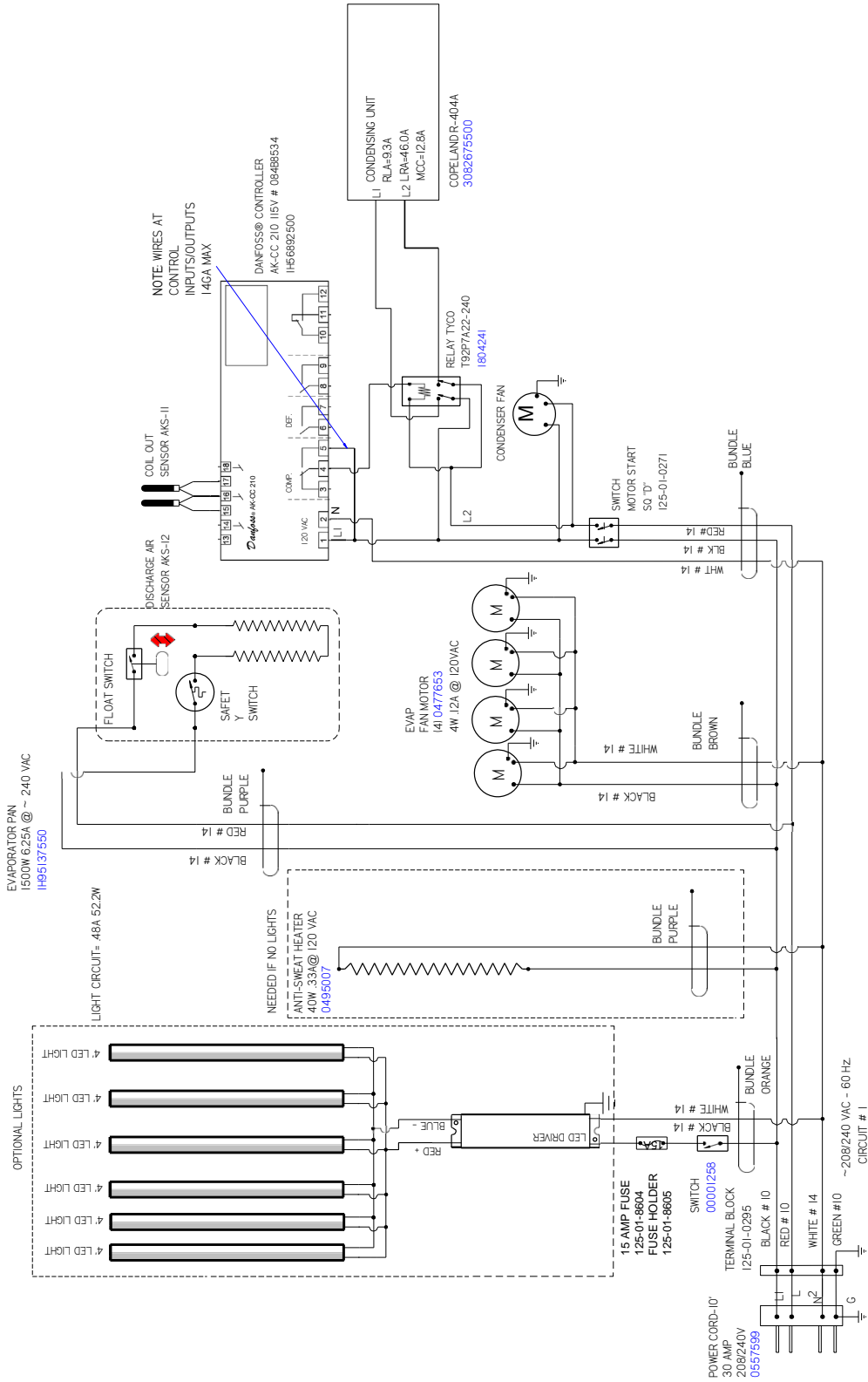

HUSSMANN
DIAGRAM-Q3-SS-8S

MATERIAL - N/A
DATE DRAWN - 8-9-17
DRAWN BY - CRAIG BOOREY
REVIEWED BY - CRAIG BOOREY
APPROVED BY - CRAIG BOOREY
UNLESS OTHERWISE SPECIFIED DIMENSIONS ARE IN INCHES
TOLERANCES ARE:
DECIMALS .XX +0.03 .XXX
+0.0 ANGL
E
PROJECTION

3041420 | C

NOTES:
CASE MUST BE GROUNDED
WHEN PASSING WIRES THROUGH METAL HOLES A GROMMET MUST BE USED

REVISION HISTORY			
REV	ECN	DATE	REVISION DESCRIPTION
A	ECN-CAP-0027093	2021/10/22	RELEASED FOR PRODUCTION
B	ECN-CAP-0027211	11/08/2021	ADDED PRESSURE SWITCH

REV	ECN	DATE	REVISION DESCRIPTION	REV BY	CHKD BY	APPR BY
A	ECN-CAP-0027093	2021/10/22	RELEASED FOR PRODUCTION	SQE	RG	RG
B	ECN-CAP-0027211	11/08/2021	ADDED PRESSURE SWITCH	SQE	RG	RG

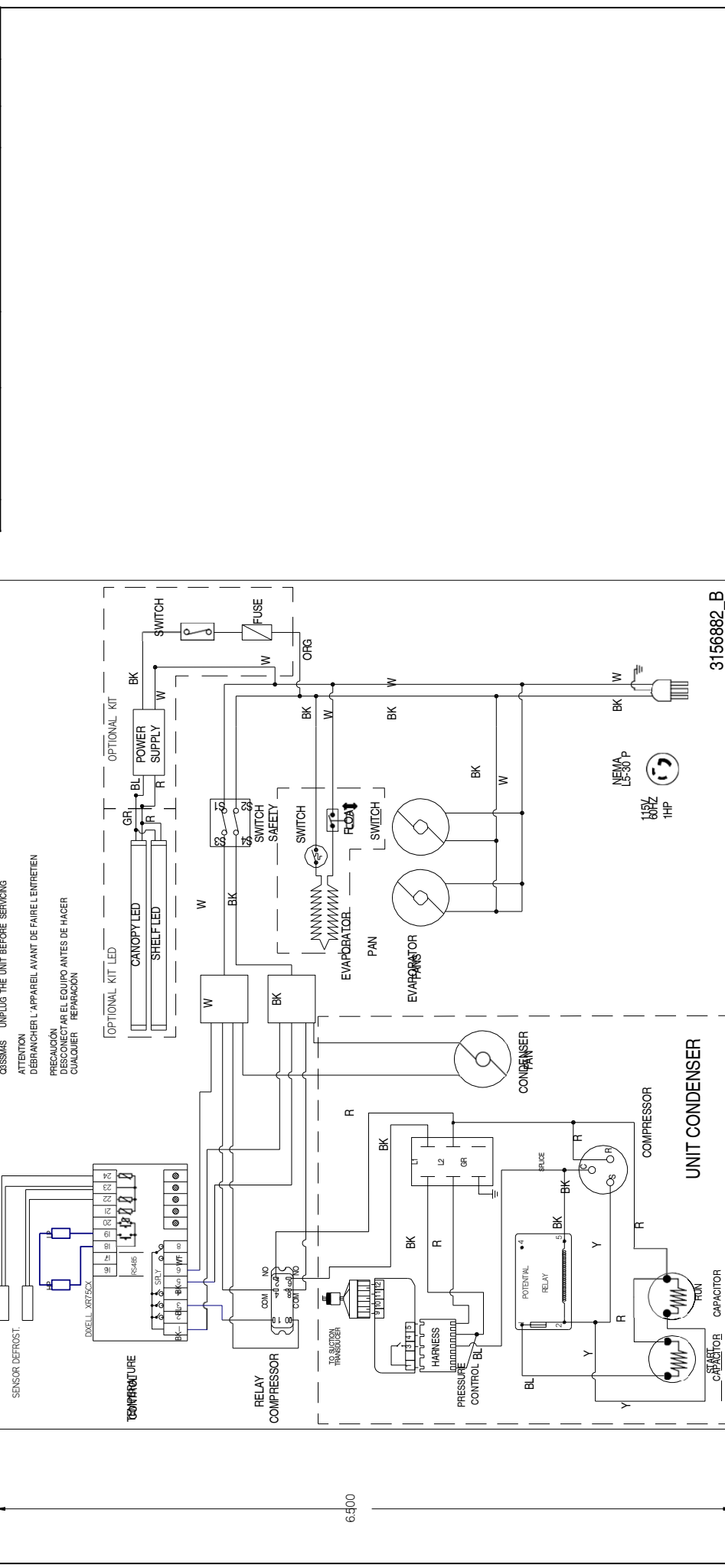

NOTES:

1. PRINTED DOCUMENT REQUIRED SETTING: ALL COLORS BLACK & WHITE
2. APPLICABLE STANDARDS / SPECIFICATIONS
ASME Y14.5M-1994 DIMENSIONS AND TOLERANCES
3. KEY PRODUCT CHARACTERISTICS PER EPR-0006 & IDENTIFIED WITH SYMBOL
4. MATERIAL- PAPER
WHITE COATING: KAOLIN
ADHESIVE: PERMANENT C4000
5. CROSS SECTION DIMENTION TOLERANCES APPLY UNLESS OTHERWISE SPECIFIED DECIMALS XXX ±.031

UL COLOR CODES / ABBREVIATIONS

- RED = RD
- BLACK = BK
- BLUE = BL
- YELLOW = YL
- GRAY = GY
- WHITE = WT
- GREEN = GN
- BROWN = BN
- ORANGE = OR
- VIOLET = VT

HUSSMANN
LABEL-WRG
DIAG Q3SSM4S
XR75

FACTORY 14GA WIRE
FACTORY TOUGA WIRE
FIELD WIRE

DO NOT SCALE DRAWING
SHEET 2 OF 2

3156882_B

REV	ECN	DATE	REVISION DESCRIPTION	REV BY	CHKD BY	APPR BY
A	ECN-CAP-0027093	2021/10/22	RELEASED FOR PRODUCTION	SCE	RG	RG
B	ECN-CAP-0027211	11/09/2021	ADDED PRESSURE SWITCH	SCE	RG	RG

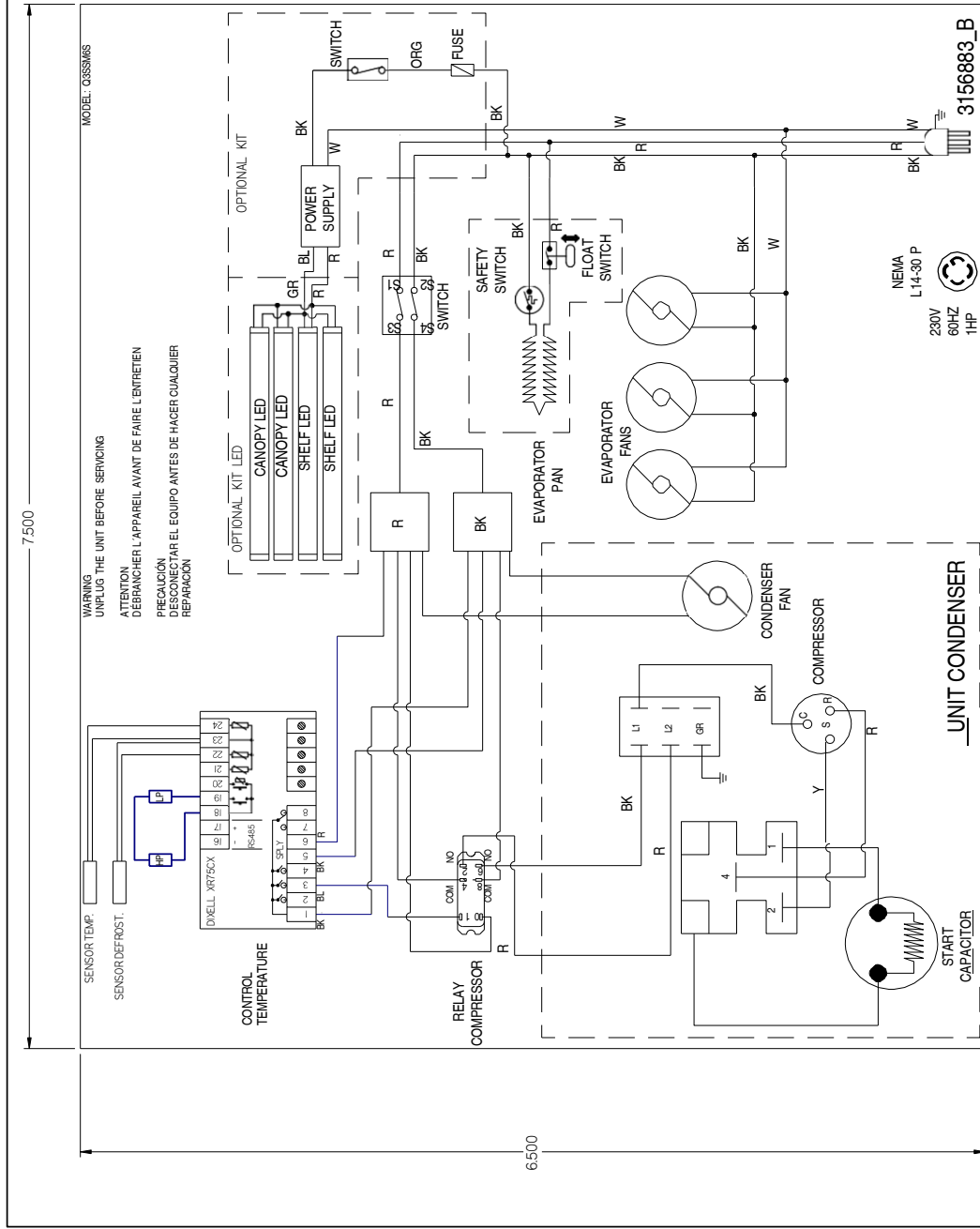

- NOTES:
1. PRINTED DOCUMENT REQUIRED SETTING: ALL COLORS BLACK & WHITE
 2. APPLICABLE STANDARDS / SPECIFICATIONS
ASME Y14.5M-1994, DIMENSIONS AND TOLERANCES
 3. KEY PRODUCT CHARACTERISTICS PER EPR-0006 & IDENTIFIED WITH SYMBOL
 4. MATERIAL - PAPER WHITE
COATING: KAOLIN
ADHESIVE: PERMANENT C4000
 5. CROSS SECTION DIMENTION TOLERANCES APPLY UNLESS OTHERWISE SPECIFIED DECIMALS XXX ±.03

UL COLOR CODES / ABBREVIATIONS	
RED = RD	WHITE = WT
BLACK = BK	GREEN = GN
BLUE = BL	BROWN = BN
YELLOW = YL	ORANGE = OR
GRAY = GY	VIOLET = VT

FACTORY 14GA WIRE	
FACTORY LOGGA WIRE	---
FIELD WIRE	---

DO NOT SCALE DRAWING	
SHEET	2 OF 2

HUSSMANN
 LABEL - WRC
 DIAG Q3SSM6S
 XR75

PN 3156883
 REV B

REVISION HISTORY				
REV	EON	DATE	REVISION DESCRIPTION	REV BY / CHKD BY
A	EON-CAP-0027093	2021/10/22	RELEASED FOR PRODUCTION	SGE / RG
B	EON-CAP-0027211	11/08/2021	ADDED PRESSURE SWITCH	SGE / RG

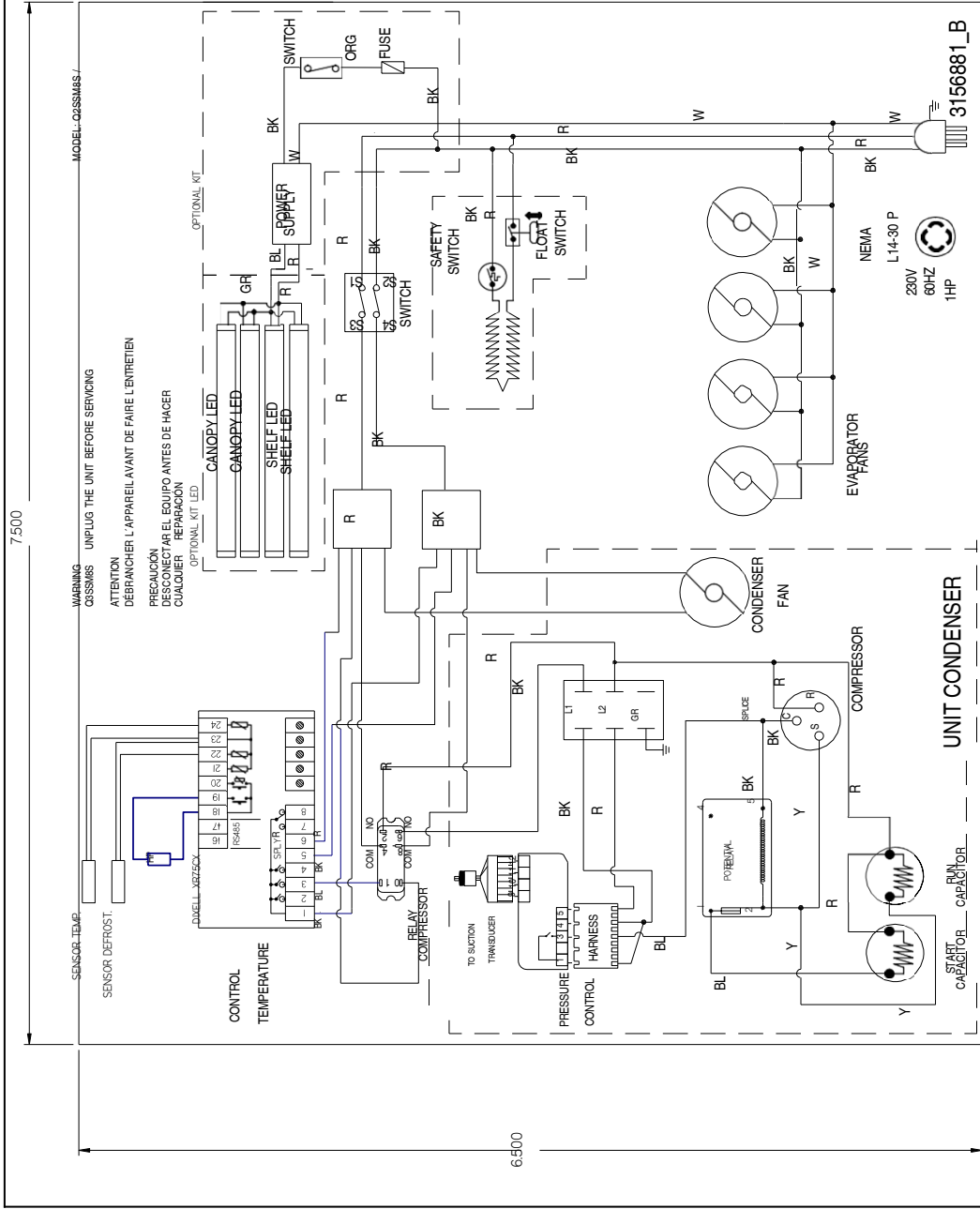

- NOTES:
1. PRINTED DOCUMENT REQUIRED SETTING: ALL COLORS BLACK & WHITE
 2. APPLICABLE STANDARDS / SPECIFICATIONS
ASME Y14.5M-1994, DIMENSIONS AND TOLERANCES
 3. KEY PRODUCT CHARACTERISTICS PER EPR-0006 & IDENTIFIED WITH SYMBOL
 4. MATERIAL - PAPER
WHITE COATING: KAOLIN
ADHESIVE: PERMANENT C4000
 5. CROSS SECTION DIMENTION TOLERANCES APPLY UNLESS OTHERWISE SPECIFIED DECIMALS XXX ±.031

UL COLOR CODES / ABBREVIATIONS	
RED = RD	WHITE = WT
BLACK = BK	GREEN = GN
BLUE = BL	BROWN = BN
YELLOW = YL	ORANGE = OR
GRAY = GY	VIOLET = VT

FACTORY 14GA WIRE
 FACTORY TOGA WIRE
 FIELD WIRE
 DO NOT SCALE DRAWING
 SHEET 2 OF 2

HUSSMANN
 LABEL-WRG DIAG
 Q2&3 SSM8S
 XR75
 3156881

B

Finishing Touches

Bumper Installation Tips

1. Start to attach the bumper at one end of the lineup, preferably on a straight case.
2. Push the end of the bumper into the bumper channel firmly. This may be difficult if bumper is cold.
3. Bend the bumper backwards to open and guide it forward onto the bumper channel.
4. An inside bumper miter must be cut on wedges.
5. Loose ends on miters must be anchored with screws on the bottom edge.
6. The top and bottom edges of the bumper must be firmly seated into the retainer by applying with a rubber mallet (not by hand).
7. The bumper should be struck by the mallet at a slight angle that forces the bumper back into itself to prevent stretching. The installation can be made easier by applying a paraffin block to the retainer grooves.

Installing Splashguard

After merchandisers have been leveled and joined, and all drip piping, electrical and refrigeration work has been completed, install the splashguards. Splashguards may be sealed to the floor using a vinyl cove base trim. The size of trim needed will depend on how much the floor is out of level.

NOTE: The splashguard must be removable to allow access to components behind it.

1. Remove all dirt, wax, debris, etc. from the area of the splashguard to ensure a secure adhesion.
2. Apply a good contact cement to the trim, allowing a proper dry time.
3. Install trim to the splashguard so that it is flush with the floor.

User Information

Stocking

Improper temperature and lighting will cause serious product loss. Discoloration, dehydration and spoilage can be controlled with proper use of the equipment and handling of product. Product temperature should always be maintained at a constant and proper temperature. This means that from the time the product is received, through storage, preparation and display, the temperature of the product must be controlled to maximize life of the product. Hussmann cases were not designed to “heat up” or “cool down” product - but rather to maintain an item’s proper temperature for maximum shelf life. To achieve the protection required always:

1. Minimize processing time to avoid damaging temperature rise to the product. Product should be at proper temperature.
2. Keep the air in and around the case area free of foreign gasses and fumes or food will rapidly deteriorate.
3. Maintain the display merchandisers temperature controls as outlined in the refrigerator section of this manual.
4. Do not place any product into these refrigerators until all controls have been adjusted and they are operating at the proper temperature. Allow merchandiser to operate a minimum of six (6) hours before stocking with any product.
5. When stocking, never allow the product to extend beyond the recommended load limit. Air discharge and return air flow must be unobstructed at all times to provide proper refrigeration.
6. Avoid the use of supplemental flood or spot lighting. Display light intensity has been designed for maximum visibility and product life at the factory. The use of higher output fluorescent lamps (H.O. and V.H.O.), will shorten the shelf life of the product.

Case Cleaning

Long life and satisfactory performance of any equipment are dependent upon the care given to it. To insure long life, proper sanitation and minimum maintenance costs, the refrigerator should be thoroughly cleaned frequently. **SHUT OFF FAN DURING CLEANING PROCESS.** It can be unplugged within the case, or shut off case at the source. The interior bottom may be cleaned with any domestic soap or detergent based cleaners. Sanitizing solutions will not harm the interior bottom, however, these solutions should always be used according to the manufacturer’s directions. It is essential to establish and regulate cleaning procedures. This will minimize bacteria causing discoloration which leads to degraded product appearance and significantly shortening product shelf life.

Soap and hot water are not enough to kill this bacteria. A sanitizing solution must be included with each cleaning process to eliminate this bacteria.

1. Scrub thoroughly, cleaning all surfaces, with soap and hot water.
2. Rinse with hot water, but do not flood.
3. Apply the sanitizing solution according to Hussmann’s directions.
4. Rinse thoroughly.
5. Dry completely before resuming operation.

Cleaning Glass and Mirrors

Only use a soft cloth and water for cleaning any glass or mirrored components. Be sure to rinse and/or dry completely.

Never use hot water on cold glass surfaces! It may shatter and cause serious injury! Allow glass surfaces to warm first.

Non-Glare Glass

The high optical clarity of this glass is possible due to special coatings on the glass surface itself. To preserve this coating and the optical clarity, keep the glass clean.

Water is the only solution recommended for use in cleaning non-glare glass. The damage to the glass from improper, caustic solutions is irreparable. In addition to cleaning the glass with the recommended product, there are precautions that should be taken when working and cleaning the inside of the case.

- When cleaning the inside of the cases, we recommend that the glass be fully opened and covered to prevent solutions from splashing onto the glass and ruining the coating on the inside.

Plexiglass and Acrylic Care

Improper cleaning not only accelerates the cleaning cycle but also degrades the quality of this surface. Normal daily buffing motions can generate static cling attracting dust to the surface. Incorrect cleaning agents or cleaning cloths can cause micro scratching of the surface, causing the plastic to haze over time.

Cleaning

Hussmann recommends using a clean damp chamois, or a paper towel marketed as dust and abrasive free with **210® Plastic Cleaner and Polish** available by calling Sumner Labs at **1-800-542-8656**. Hard, rough cloths or paper towels will scratch the acrylic and should not be used.

Antistatic Coatings

The **210®** has proven to be very effective in not only cleaning and polishing the Plexiglass surface, but also providing anti-static and anti-fog capabilities. This product also seals pores and provides a protective coating.

Maintenance



IMPORTANT INFORMATION

Please read these instructions completely before beginning case installation



DANGER

**BEFORE SERVICING
ALWAYS DISCONNECT ELECTRICAL
POWER AT THE MAIN DISCONNECT
WHEN SERVICING OR REPLACING ANY
ELECTRICAL COMPONENT.**

**This includes (but not limited to) Fans, Heaters
Thermostats, and Lights.**

Evaporator Fans

The evaporator fans are located at the center front of these merchandisers directly beneath the display pans. *Should fans or blades need servicing, always replace fan blades with the raised embossed side of the blade TOWARD THE MOTOR.*

Copper Coils

The copper coils used in Hussmann merchandisers may be repaired in the field. Materials are available from local refrigeration wholesalers.

Hussmann recommends using #15 Sil-Fos for repairs.

Tips and Troubleshooting

Before calling for service, check the following:

1. Check electrical power supply to the equipment for connection.
2. Check fixture loading. Overstocking case will affect its proper operation.
3. If frost is collecting on fixture and/or product, check that Humidity Control is working properly, and that no outside doors or windows are open - allowing moisture to enter store.

CAUTION

CLEANING PRECAUTIONS

When cleaning:

- Do not use high pressure water hoses
- Do not introduce water faster than waste outlet can drain
- NEVER INTRODUCE WATER ON SELF CONTAINED UNIT WITH AN EVAPORATOR PAN
- NEVER USE A CLEANING OR SANITIZING SOLUTION THAT HAS AN OIL BASE (these will dissolve the butyl sealants) or an AMMONIA BASE (this will corrode the copper components of the case)
- TO PRESERVE THE ATTRACTIVE FINISH:
- DO USE WATER AND A MILD DETERGENT FOR THE EXTERIOR ONLY
- DO NOT USE A CHLORANITED CLEANER ON ANY SURFACE
- DO NOT USE ABRASIVES OR STEEL WOOL SCOURING PADS (these will mar the finish)

Glass Replacement and Adjustment Instructions

In order to replace or adjust the glass, the glass must be placed in the raised position. The underside of the clamp is exposed, revealing the tightening screws. By turning these screws counterclockwise 1/4 turn each, the glass will be loosened for either removal or adjustment.

Note: Do not overtighten the screws since damage may occur.

Stainless Steel Cleaning and Care

There are three basic things, which can break down your stainless steel's passivity layer and allow corrosion.

1. Mechanical Abrasion

Mechanical Abrasion means those things that will scratch the steel's surface. Steel Pads, wire Brushes, and Scrapers are prime examples.

2. Water

Water comes out of our tap in varying degrees of hardness. Depending on what part of the country you live in, you may have hard or soft water. Hard water may leave spots. Also, when heated, hard water leaves deposits behind that if left to sit, will break down the passive layer and rust your stainless steel. Other deposits from food preparation and

Maintenance (Cont'd)

service must be properly removed.

3. Chlorides

Chlorides are found nearly everywhere. They are in water, food and table salt. One of the worst perpetrators of chlorides can come from household and industrial cleaners.

Don't Despair! Here are a few steps that can help prevent stainless steel rust.

1. Use the Proper Tools

When cleaning your stainless steel products, take care to use non-abrasive tools. Soft Clothes and plastic scouring pads will NOT harm the steel's passive layer. Stainless steel pads can also be used but the scrubbing motion must be in the same direction of the manufacturer's polishing marks.

2. Clean With the Polish Lines

Some stainless steels come with visible polishing lines or "grain". When visible lines are present, you should ALWAYS scrub in a motion that is parallel to them. When the grain cannot be seen, play it safe and use a soft cloth or plastic scouring pad.

3. Use Alkaline, Alkaline Chlorinated or Non-chloride Containing Cleaners

While many traditional cleaners are loaded with chlorides, the industry is providing an ever increasing choice of non-chloride cleaners. If you are not sure of your cleaner's chloride content contact your cleaner supplier. If they tell you that your present cleaner contains chlorides, ask for an alternative. Also, avoid cleaners containing quaternary salts as they also can attack stainless steel & cause pitting and rusting.

4. Treat your Water

Though this is not always practical, softening hard water can do much to reduce deposits. There are certain filters that can be installed to remove

distasteful and corrosive elements. Salts in a properly maintained water softener are your friends. If you are not sure of the proper water treatment, call a treatment specialist.

5. Keep your Food Equipment Clean

Use alkaline, alkaline chlorinated or non-chlorinated cleaners at recommended strength. Clean frequently to avoid build-up of hard, stubborn stains. If you boil water in your stainless steel equipment, remember the single most likely cause of damage is chlorides in the water. Heating cleaners that contain chlorides has a similar effect.

6. RINSE, RINSE, RINSE

If chlorinated cleaners are used you must rinse, rinse, rinse and wipe dry immediately. The sooner you wipe off standing water, especially when sit contains cleaning agents, the better. After wiping the equipment down, allow it to air dry for the oxygen helps maintain the stainless steel's passivity film.

7. Never Use Hydrochloric Acid (Muriatic Acid) on Stainless Steel.

8. Regularly Restore/Passivate Stainless Steel.

Appendices

Appendix A. - Temperature Guidelines - Refrigerated

The refrigerators should be operated according to the manufacturer's published engineering specifications for entering air temperatures for specific equipment applications. Table 1 shows the typical temperature of the air entering the food zone one hour before the start of defrost and one hour after defrost for various categories of refrigerators. Refer to Appendix C for Field Evaluation Guidelines.

Type of Refrigerator	Typical Entering Air Temperature
I. OPEN DISPLAY	
A. Non frozen:	
1) Meat	28°F
2) Dairy/Deli	32°F
3) Produce	
a. Processed	36°F
b. Unprocessed	45°F
B. Frozen	0°F
C. Ice Cream	-5°F
II. CLOSED DISPLAY	
A. Non frozen:	
1) Meat	34°F
2) Dairy/Deli	34°F
3) Produce	
a. Processed	36°F
b. Unprocessed	45°F
B. Frozen	0°F
C. Ice Cream	-5°F

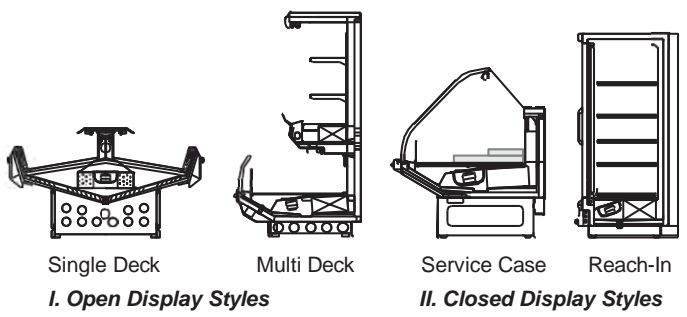

Appendix B. - Application Recommendations - Refrigerated

1. Temperature performance is critical for controlling bacteria growth. Therefore, the following recommendations are included in the standard. They are based on confirmed field experience over many years.
2. The installer is responsible for following the installation instructions and recommendations provided by Hussmann for the installation of each individual type refrigerator.
2. Refrigeration piping should be sized according to the equipment manufacturer's recommendations and installed in accordance with normal refrigeration practices. Refrigeration piping should be insulated according to Hussmann's recommendations.

3. A clogged waste outlet blocks refrigeration. The installer is responsible for the proper installation of the system which dispenses condensate waste through an air gap into the building indirect waste system.
4. The installer should perform a complete start-up evaluation prior to the loading of food into the refrigerator, which includes such items as:
 - a) Initial temperature performance, Coils should be properly fed with a refrigerant according to manufacturer's recommendations.
 - b) Observation of outside influences such as drafts, radiant heating from the ceiling and from lamps. Such influence should be properly corrected or compensated for.
 - c) At the same time, checks should be made of the store dry-bulb and wet-bulb temperatures to ascertain that they are within the limits prescribed by Hussmann.
 - d) Complete start-up procedures should include checking through a defrost to make certain of its adequate frequency and length without substantially exceeding the actual needs. This should include checking the electrical or refrigerant circuits to make sure that defrosts are correctly programmed for all the refrigerators connected to each refrigeration system.
 - e) Recording instruments should be used to check performance.

Appendix C. - Field Recommendations - Refrigerated
Recommendations for field evaluating the performance of retail food refrigerators and hot cases

- 1.0 The most consistent indicator of display refrigerator performance is temperature of the air entering the product zone (see Appendix A). In practical use, the precise determination of return air temperature is extremely difficult. Readings of return air temperatures will be variable and results will be inconsistent. The product temperature alone is not an indicator of refrigerator performance.

NOTE: Public Health will use the temperature of the product in determining if the refrigerator will be allowed to display potentially hazardous food. For the purpose of this evaluation, product temperature above the FDA Food Code 1993 temperature for potentially hazardous food will be the first indication that an evaluation should be performed. It is expected that all refrigerators will keep food at the FDA Food Code 1993 temperature for potentially hazardous food.

Appendices (Cont'd)

1. The following recommendations are made for the purpose of arriving at easily taken and understood data which, coupled with other observations, may be used to determine whether a display refrigerator is working as intended:
 - a) **INSTRUMENT** - A stainless steel stem-type thermometer is recommended and it should have a dial a minimum of 1 inch internal diameter. A test thermometer scaled only in Celsius or dually scaled in Celsius and Fahrenheit shall be accurate to 1°C (1.8°F). Temperature measuring devices that are scaled only in Fahrenheit shall be accurate to 2°F. The thermometer should be checked for proper calibration. (It should read 32°F when the stem is immersed in an ice water bath).
 - b) **LOCATION** - The probe or sensing element of the thermometer should be located in the airstream where the air first enters the display or storage area, and not more than 1 inch away from the surface and in the center of the discharge opening.
 - c) **READING** - It should first be determined that the refrigerator is refrigerating and has operated at least one hour since the end of the last defrost period. The thermometer reading should be made only after it has been allowed to stabilize, i.e., maintain a constant reading.
 - d) **OTHER OBSERVATIONS** - Other observations should be made which may indicate operating problems, such as unsatisfactory product, feel/appearance.
 - e) **CONCLUSIONS** - In the absence of any apparent undesirable conditions, the refrigerator should be judged to be operating properly. If it is determined that such condition is undesirable, i.e., the product is above proper temperature, checks should be made for the following:
 1. Has the refrigerator been loaded with warm product?
 2. Is the product loaded beyond the "Safe Load Line" markers?
 3. Are the return air ducts blocked?
 4. Are the entering air ducts blocked?
 5. Is a dumped display causing turbulent air flow and mixing with room air?
6. Are spotlights or other high intensity lighting directed onto the product?
7. Are there unusual draft conditions (from heating/air-conditioning ducts, open doors, etc.)?
8. Is there exposure to direct sunlight?
9. Are display signs blocking or diverting airflow?
10. Are the coils of the refrigerator iced up?
11. Is the store ambient over 75°F, 55% RH as set forth in ASHRAE Standard 72 and ASHRAE Standard 117?
12. Are the shelf positions, number, and size other than recommended by Hussmann?
13. Is there an improper application or control system?
14. Is the evaporator fan motor/blade inoperative?
15. Is the defrost time excessive?
16. Is the defrost termination, thermostat (if used) set too high?
17. Are the refrigerant controls incorrectly adjusted?
18. Is the air entering the condenser above design conditions? Are the condenser fins clear of dirt, dust, etc.?
19. Is there a shortage of refrigerant?
20. Has the equipment been modified to use replacements for CFC-12, CFC-502 or other refrigerant? If so, have the modifications been made in accordance with the recommendations of the equipment manufacturer? Is the refrigerator charged with the proper refrigerant and lubricant? Does the system use the recommended compressor?

Appendix D. - Recommendations to User - Refrigerated

- 1.0 Hussmann Corporation provides instructions and recommendations for proper periodic cleaning. The user will be responsible for such cleaning, including the cleaning of low temperature equipment within the compartment and the cooling coil area(s). Cleaning practices, particularly with respect to proper refrigerator unloading and warm-up, must be in accordance with applicable recommendations.

Appendices (Cont'd)

- 1.1 Cleaning of non frozen food equipment should include a weekly cleaning of the food compartment as a minimum to prevent bacteria growth from accumulating. Actual use and products may dictate more frequent cleaning. Circumstances of use and equipment design must also dictate the frequency of cleaning the display areas. Weekly washing down of the storage compartment is also recommended, especially for equipment subject to drippage of milk or other liquids, or the collection of vegetable, meat, crumbs, etc. or other debris or litter. Daily cleaning of the external areas surrounding the storage or display compartments with detergent and water will keep the equipment presentable and prevent grime buildup.
2. Load levels as defined by the manufacturer must be observed.
3. The best preservation is achieved by following these rules:
 - a) Buy quality products.
 - b) Receive perishables from transit equipment at the ideal temperature for the particular product.
 - c) Expedite perishables to the store's storage equipment to avoid unnecessary warm-up and prolonged temperature recovery. Food store refrigerators are not food chillers nor can they reclaim quality lost through previous mishandling.
 - d) Care must be taken when cross merchandising products to ensure that potentially hazardous vegetable products are not placed in non refrigerated areas.
 - e) Display and storage equipment doors should be kept closed during periods of inactivity.
 - f) Minimize the transfer time of perishables from storage to display.
 - g) Keep meat under refrigeration in meat cutting and processing area except for the few moments it is being handled in processing. When a cut or tray of meat is not to be worked on immediately, the procedure should call for returning it to refrigeration.
 - h) Keep tools clean and sanitized. Since mechanical equipment is used for fresh meat processing, all such equipment should be cleaned at least daily and each time a different kind of meat product comes in contact with the tool or equipment.
 - i) Make sure that all refrigeration equipment is installed and adjusted in strict accordance with the manufacturer's recommendations.
 - j) See that all storage and refrigeration equipment is kept in proper working order by routine maintenance.



This warning does not mean that Hussmann products will cause cancer or reproductive harm, or is in violation of any product-safety standards or requirements. As clarified by the California State government, Proposition 65 can be considered more of a 'right to know' law than a pure product safety law. When used as designed, Hussmann believes that our products are not harmful. We provide the proposition 65 Warning to stay in compliance with California state law. It is your responsibility to provide accurate Proposition 65 Warning labels to your customers when necessary. For more information on Proposition 65, please visit the California State government website.

For further technical information, please log on to <http://www.hussmann.com/products/Q3-SS.htm>

Service Record

Last service date: By:

_____	_____
_____	_____
_____	_____
_____	_____
_____	_____
_____	_____
_____	_____

HUSSmann®/Chino
Additional copies of this publication may be obtained by contacting:
Hussmann® Chino
13770 Ramona Avenue • Chino, California 91710
(909) 628-8942 FAX
(909) 590-4910
(800) 395-9229

The <i>MODEL NAME</i> and <i>SERIAL NUMBER</i> is required in order to provide you with the correct parts and information for your particular unit. They can be found on a small metal plate on the unit. Please note them below for future reference.
MODEL:
SERIAL NUMBER: