

Installation  
& Operation  
Manual

REV. 1024

**HUSSmann®/CHINO**

**Q-H HOT FOOD FAMILY  
SINGLE-DECK SERVICE  
HOT FOOD CASE**

**HUSSmann®**

Q-H Hot Food Family  
**SINGLE-DECK SERVICE HOT FOOD CASE**



---

INSTALLATION & OPERATION GUIDE

---

## 1. General Instructions

### **HUSSMANN®/CHINO**

A publication of HUSSMANN® Chino  
13770 Ramona Avenue • Chino, California 91710  
(909) 628-8942 FAX  
(909) 590-4910  
(800) 395-9229

[www.hussmann.com](http://www.hussmann.com)

**This Booklet Contains Information on:**

#### ***Q-H: Hot Food Cases***

##### **Shipping Damage**

All equipment and separately packaged accessories should be carefully removed, and thoroughly examined for shipping damage during unloading. This equipment has been carefully inspected at our factory and the carrier has assumed responsibility for its safe arrival. If it is indeed damaged, either apparent or concealed a claim must be filed with carrier.

##### **Apparent Loss or Damage**

If there is an obvious loss or damage, it must be noted on the freight bill or express receipt and signed by the carrier's agent; otherwise, carrier may refuse claim. The carrier will supply necessary claim forms.

##### **Concealed Loss or Damage**

When loss or damage is not apparent until after equipment is uncrated, a claim for concealed damage is made. Make request in writing to carrier for inspection within 15 days and retain all packaging. The carrier will supply inspection report and required claim forms.

##### **Shortages**

Check your shipment for any possible shortages of material. If a shortage should exist and is found to be the responsibility of Hussmann Chino, notify Hussmann Chino. If such a shortage involves the carrier, notify the carrier immediately, and request an inspection. Hussmann Chino will acknowledge shortages within ten days from receipt of equipment.

##### **Hussmann Chino Product Control**

The serial number and shipping date of all equipment has been recorded in Hussmann's files for warranty and replacement part purposes. All correspondence pertaining to warranty or parts ordering must include the serial number of each piece of equipment involved, in order to provide the customer with the correct parts.

**Keep this booklet with the case at all times for future reference.**

---

## 2. Table of Contents

<b>1. General Instructions.....</b>	<b>2</b>
<b>3. Cut and Plan Views .....</b>	<b>4</b>
<b>4. Installation.....</b>	<b>5</b>
<b>5. Plumbing .....</b>	<b>13</b>
<b>6. Electrical.....</b>	<b>14</b>
<b>7. User Information.....</b>	<b>15</b>
<b>8. Maintenance.....</b>	<b>22</b>
<b>9. Specification Sheets .....</b>	<b>23</b>
<b>10. Wiring Diagram Index .....</b>	<b>25</b>
<b>11. Wiring Diagrams .....</b>	<b>27</b>
<b>12. Troubleshooting Guide .....</b>	<b>66</b>
<b>13. Appendices .....</b>	<b>68</b>
Appendix A. - Temperature Guidelines .....	68
Appendix B. - Application Recommendations .....	68
Appendix C. - Field Recommendations.....	68
Appendix D. - Recommendations to User.....	69

### 3. Cut and Plan Views

Engineering  
Cross Section

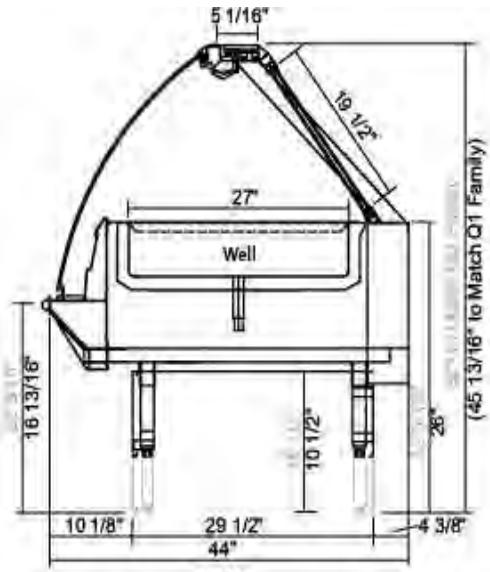

**Q-HC**  
Single Deck Hot Service - Curved Glass



**Q-HC-SS**  
Single Deck Hot Self-Service - Curved Glass

Engineering  
Plan View

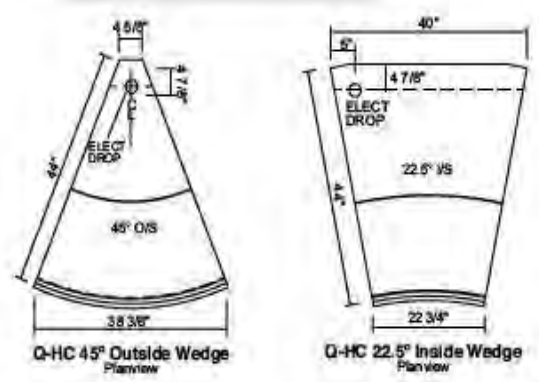

**Q-HC 45° Outside Wedge**  
Planview

**Q-HC 22.5° Inside Wedge**  
Planview

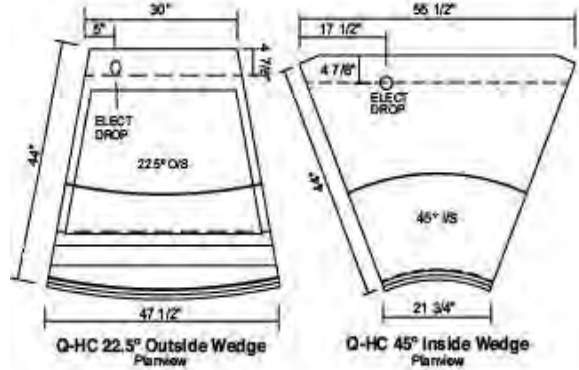

**Q-HC 22.5° Outside Wedge**  
Planview

**Q-HC 45° Inside Wedge**  
Planview

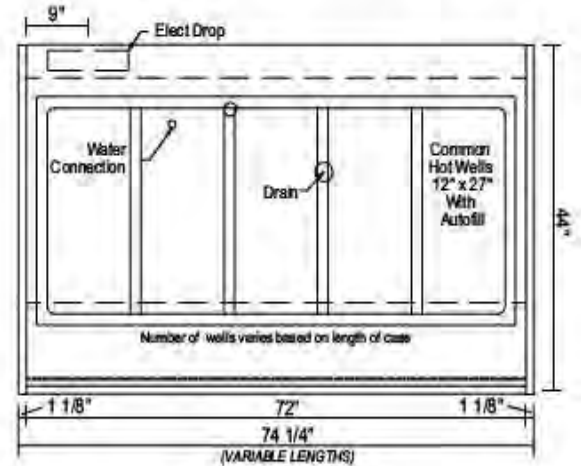

**Q-H Plan View**  
Straight Section

## 4. Installation

### Leveling/Joining Instructions

1. Check floor where cases are to be set to see if it's level then determine where the highest part of the floor is. Cases will be shimmed off this point. Using case blueprints, measure off and mark on floor the exact dimensions of the case footprint. Snap chalk line for front and back position of base rail. Mark location of each joint front and back. Use a transit to find the highest point along both lines.

**IMPORTANT: It is imperative that cases be leveled front to back and side to side prior to joining. A level case is necessary to ensure proper operation, water drainage, glass alignment, and operation of the hinges supporting the glass. Leveling the case correctly will solve most hinge operation problems.**



**AVOID REMOVING CONCRETE BEGIN LINEUP AT HIGHEST POINT of Store Floor.**  
**All cases were leveled and joined prior to shipment to ensure closest possible fit when cases are joined in the field.**

2. Position first case in lineup, remove shipping supports and level. To level the case, twist the adjustable foot in a clockwise or counterclockwise direction to lengthen or shorten the leg. Case must be raised using shipping supports, to prevent damage to case. With the aid of the shipping supports, the case may be lifted with the forklift or pushed into proper position for setting. If a wedge is used in the middle of a line up, the wedge must be set off the highest point on the floor FIRST, with the rest of the lineup being leveled from it.
3. Set second case within one (1) foot of the first case. Remove the shipping brace facing the first case only, and level case by twisting the feet as in the first case. Remove front and rear panels closest to the case joints.
4. Apply liberal bead of case joint sealant (butyl) between cases along bulkhead (See diagram).  
**DO NOT USE PERMAGUM!**  
 Permagum does not allow cases to draw up tight, and therefore leaves gaps at the joint.
5. Bolt cases together and remove the remaining shipping supports.
6. Place stainless strap over joint seam (if applicable), attach via butyl or rivets.
7. Recheck all bolts.

**Should glass need readjustment after leveling, see "Maintenance Section" of this guidebook.**

### Bolt and Sealant Locations

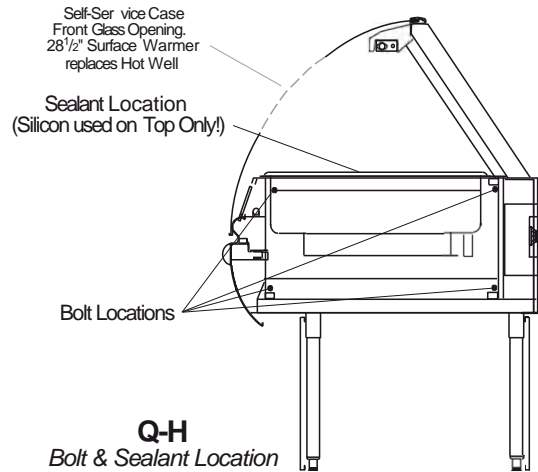

### Common End Between Unlike Cases and Hot Cases

Bolt end onto case using bolts provided in predrilled holes behind front panel through bracket provided, and in the rear behind the rear access panel on the bottom. Hot case are only bolted in two places.

### Finishing Touches

**(Perform after plumbing and electrical)**

#### Access Panels

All electrical and drain access panels are clearly labeled on the deck of the stand.

#### Installing Splashguard

After merchandisers have been leveled and joined and all electrical and plumbing work has been completed, install the splashguards. After adjusting brackets flush with the floor, position splashguard up behind the front panel first-then position the lower portion over the previously adjusted brackets. Splashguards may be sealed to the floor using a vinyl cove base trim. The size of trim needed will depend on how much the floor is out of level.

## Installation (Cont'd)

**NOTE:** The splashguard must be removable to access components behind it.

1. Remove all dirt, wax etc from the area of the splashguard to ensure a secure adhesion.
2. Apply a good contact cement to the trim, allowing for proper dry-time.
3. Install trim to the splashguard so that it is flush with floor.

**Do not seal trim to floor!**

### Line Up Tab



### Line Up Plate



### Q-1 Glass Adjustment

Proper adjustment of the side-to-side position on the glass clamp on Vieler Streamline hardware such as used on Hussmann Q series service cases is critical to proper operation of the glass hardware. Failure to properly adjust the glass clamp can result in failure of the hardware and possible injury to personnel.

When setting or repairing cases, the glass clamp is frequently adjusted from side to side once the cases are set in order to control glass gaps or compensate for poorly installed case line ups. Due to the unique design of this type of hardware, using practices common to other types of hardware can result in the above failures.

#### Step 1: Level Case

The canopy hardware and glass gaps are set at the factory for proper fit with the Cases Square and level. Before attempting to do any adjustment of the canopy hardware, ensure that the cases are set square and level. Additionally, the adjoining cases must be pulled together tightly.

**To adjust the front glass please follow these steps**  
Before you start any adjustments make sure the cases are level, Front to Back and side to side



#### Step # 2

To level the cases remove the front and rear close-offs, You can adjust the Height by turning the base leg adjusters

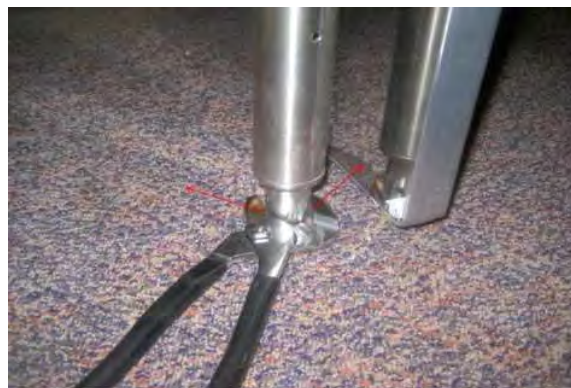

When you turn the leg adjuster clock-wise the case will go up.

When you turn the leg adjuster counter clock-wise the case will go down.

# Installation (Cont'd)

**IMPORTANT:** Attempting to compensate for poor installation practices by manipulating the canopy hardware will result in unsatisfactory workmanship and possibly cause hardware failure and/or injury.

### Step 3: Adjusting Glass Height

After the cases are set and level, rear covers must be removed to access the glass height adjusters



Some cases have wrapping boards installed, the wrapping boards need to be removed to be able to remove the small rear covers. Unhook at K-99 bracket. Remove the small rear covers under each rear canopy arm to access the arm adjusters.

### Step # 4

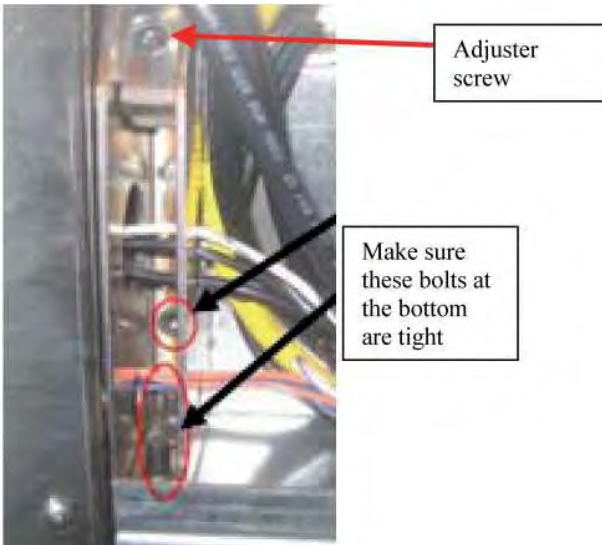

Loosen the two lock screws on the side (do not remove)



To properly adjust the height of the glass requires that both hinge arms of each section of glass be loosened before attempting to change the glass position.

Turning the bolt clock-wise, the front glass will go down. Turning the bolt counter clock-wise, the front glass will go up.

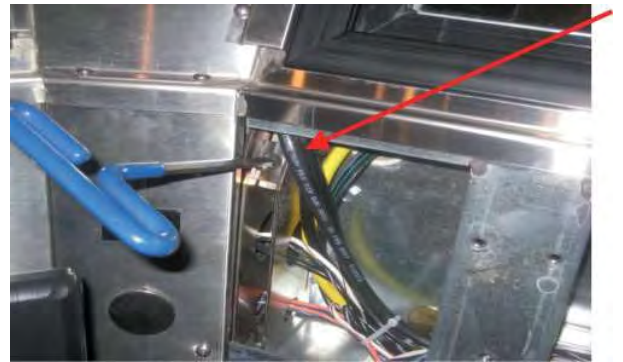

## Installation (Cont'd)



Glass must be parallel to ledge when viewed from front.

**IMPORTANT:** Attempting to compensate for poor installation practices by manipulating the canopy hardware will result in unsatisfactory workmanship and possibly cause hardware failure and/or injury.

### Step 5: Glass Side to Adjustment

The glass gaps can be slightly optimized by moving the glass and glass clamp assembly side to side. This should be done as the final adjustment only after the glass/canopy height of the cases are set and leveled to each other. The canopy hardware on adjoining Q Series cases should be screwed together with the 1/4"-20 THD screws included with the cases. There are threaded holes provided in the stationary portion of the top hardware for this purpose.

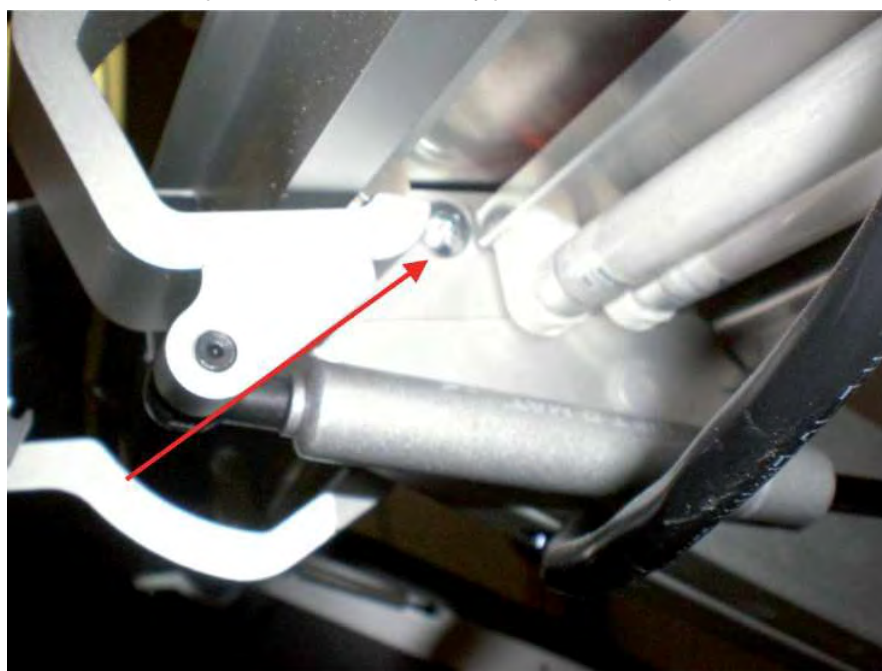

## Installation (Cont'd)

To adjust glass to glass gaps see the following.



To properly adjust the glass gaps requires that both hinge arms of each section of glass be loosened before attempting to change the glass position.

To shift the glass side to side or front to back at the glass clamp open the glass and loosen the TORX T-15 screw.

To shift the glass side to side or front to back at the glass clamp

#1 Open the glass and loosen the Torx T-15 screw

# 2 Loosen the #10 MM bolt on both sides of the glass as needed



## Installation (Cont'd)

Torque Specs:

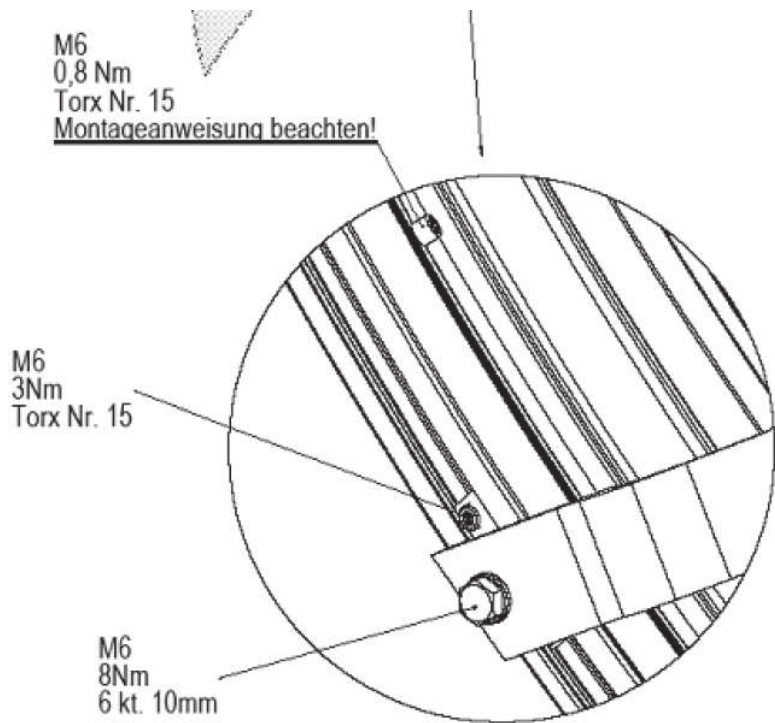

**IMPORTANT:** Attempting to change the glass position by loosening only one side or by forcing the clamp sideways will result in damaging the hardware and its eventual failure. Loosening the hinge arms requires loosening the attachment screws and setscrews on both hinge arms on the section of glass.

**IMPORTANT:** It is critical to use the proper size Torx or Hex wrench for the fasteners to avoid stripping the fasteners.

**NOTE:** LOCTITE MUST BE APPLIED TO SCREWS BEFORE INSTALLATION AND MUST REAPPLY LOCTITE IF SCREWS HAVE BEEN REMOVED EXPIRING THE INTIAL APPLICATION FOR READJUSTMENT PURPOSES.

---

## Installation (Cont'd)

Loosen the fasteners only as needed to allow the glass clamp to slip to the desired position.

Reposition the glass and glass clamp assembly as needed and verify its position by carefully closing the glass to check clearances.

Once the glass is in the desired position, retighten the fasteners at the hinge arms with the proper wrench.

Recheck the glass position and double check that the fasteners are properly torqued.

**IMPORTANT:** It is critical that the hinge arm washers or bushings that fasten the hinge arms to the stationary portion of the upper glass hardware do not have any side pressure on them. Even the slightest side pressure will result in the failure of the hardware. If the retaining clips or hinge arm washers or bushings at each hinge arm have any side pressure it is necessary to repeat the adjustment procedure.

When properly adjusted, the hinge arm washers or bushings will have a slight side-to-side free play.

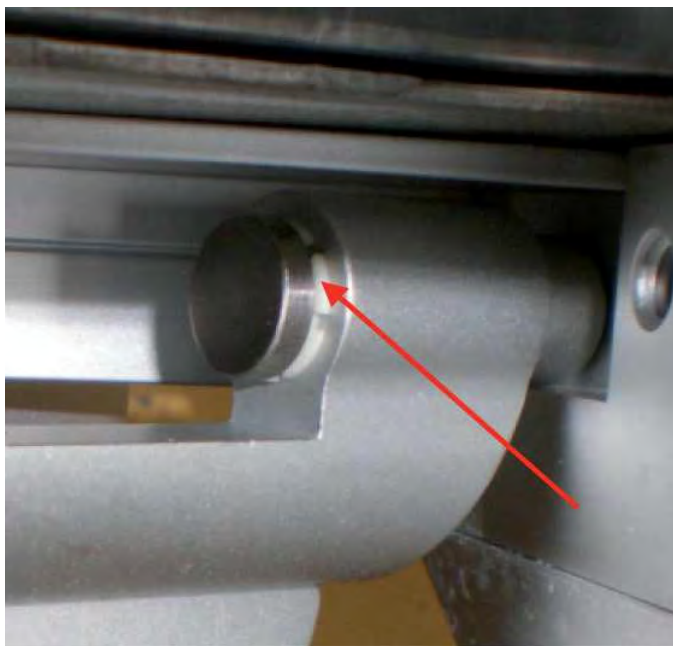

## Installation (Cont'd)

### Bumper Installation Instructions



Step 1: Make sure the aluminum channel and end caps are installed.



Step 2: Use silicone lubricant to help the bumper slide into the channel.



Step 3: Starting on one end: while inserting the bumper, push it up against the end cap to prevent the bumper from shrinking after installation (when it gets cold).



Step 4: As you insert the bumper into the channel with one hand, pull the bumper toward you with the other to open the inside lips. Slowly apply pressure by rolling the bumper into the track.

### NSF Compliant Sealing of The Case to The Floor

When the appliance is designed to be sealed to the floor or countertop the following procedure must be followed to establish proper sanitary operation. First, ensure the floor area is clean and free from debris. Begin by positioning the appliance in its designated installation spot, ensuring sufficient clearance on the back and sides according to the specified "Clearances" for proper ventilation. Next, level the appliance from front to back and side to side, as described in "Method for Leveling." Once level, outline the base of the appliance on the floor. Then, lift and support the front of the appliance. Apply a bead of NSF-approved sealant to the floor, positioned about 1/2 inch (13 mm) inside the front part of the outline. The bead should be substantial enough to cover the entire appliance surface when lowered onto it. Afterward, raise and support the rear of the appliance and apply the sealant to the floor along the remaining three sides. Finally, carefully lower the appliance and inspect it to ensure a complete seal around the entire perimeter and clean off any extra sealant as necessary. Once the appliance is sealed in accordance with these procedures, the result is intended to prevent liquid spillage on adjacent surfaces of the floor or countertop from passing under inaccessible portions of the equipment.

## 5. Plumbing

### Waste Outlet

The waste outlet is located under the hot wells and can be accessed from the back. Drain is 1" copper. A stub is provided for extending to sink. Drain must be run in a material that will withstand a 150°F (66°C) (or more) temperature, such as copper.

### Water Supply Connection

The well fill water hose on these models will need to be connected to a water supply. The water connection is 1/2" and consists of a hand gate valve. If the water pressure exceeds 45 psi, a water pressure regulating valve should be installed in the supply line, and set at 30-35 psi outlet pressure. The pressure regulating valve is not supplied by Husmann.



**Do not plumb below the sliding plate  
on the side of the hot well!  
Doing so may interfere with the  
ability to adjust the water within the well!**



**Damage may occur if cold water is fed  
into a preheated hot well too quickly!**

For a quick preheat time, the customer may want to pipe in hot water. If hot water is piped into the case, temperature of water supply must not exceed 150°F (66°C). In areas where water contains a heavy mineral content, it may be a good idea to install a cartridge-type water filtration system.

Proper water depth is 1". These cases come equipped with an auto-fill system designed to slowly feed in water to maintain the proper water level, and prevent damage incurred when cold water is fed too fast into a hot well. In common well configurations, the water level is regulated by adjusting the probe on the inside of the well. In multi-well configurations, use the sliding plate at the rear of the case to adjust the float level. The water level is maintained in direct relation to the vertical position of the plate. The water feeds in slowly, so it is not necessary to shut water off during cleaning. It is advisable to allow a number of hours for the system to refill. If necessary, the case may also be filled manually, with the use of buckets.

NOTE: Some local codes may require the installation of check valves in the water supply.

## 6. Electrical

### Wiring Color Code

STANDARD CASE WIRE COLOR CODE CÓDIGO DE COLORES DE LOS ALAMBRES PARA LAS VITRINAS ESTANDAR CODE COULER POUR FILS DE BOITIER NORMALISE		
COLOR DESCRIPTION	DESCRIPCION	DESCRIPTION
■ GROUND	TIERRA MASA	MASSE
■ ANTI-SWEAT	ANTICONDENSACION	ANTI-SUINTEMENT
■ LIGHTS	LUJES	ECLAIRAGE
■ RECEPTACLES	ENCHUFES	PRISE DE COURANT
■ T-STAT/SOLENOID 230VAC	TERMOSTATO/SOLENOIDE (230VAC)	SOUPAPE A SOLENOID (230 VAC)
■ T-STAT/SOLENOID 115VAC	TERMOSTATO/SOLENOIDE (115VAC)	SOUPAPE A SOLENOID (115 VAC)
■ T-STAT/SOLENOID 24VAC	TERMOSTATO/SOLENOIDE (24VAC)	SOUPAPE A SOLENOID (24 VAC)
■ FAN MOTORS	VENTILADORES	VENTILATEUR
■ BLUE CONDENSING UNIT	UNIDAD DE CONDENSACION	UNITE DE CONDENSATION

USE COPPER CONDUCTORS ONLY  
UTILISEZ LES CONDUCTEURS DE CUIVRE SEULEMENT  
UTILICE LOS CONDUCTORES DE COBRE SOLAMENTE  
430-01-0338 R101003



**DANGER**

**BEFORE SERVICING**

**ALWAYS DISCONNECT ELECTRICAL**

**POWER AT THE MAIN DISCONNECT**

**WHEN SERVICING OR REPLACING ANY**

**ELECTRICAL COMPONENT.**

**This includes (but not limited to) Fans, Heaters**

**Thermostats, and Lights.**

### Electrical Circuit Identification

An electrical junction box is provided under left hand button end of case. A terminal block is also located there - 3Ø 240/ 208 volts with a neutral should be provided.

### Electrical Receptacles (When Applicable)

The receptacles located on the exterior of the merchandiser are intended for scales and lighted displays. They are not intended nor suitable for large motors or other external appliances.

### Wiring and Serial Plate Amperage

Field Wiring must be sized for component amperes stamped on the serial plate. Actual ampere draw may be less than specified. Case amperes are listed on the wiring diagram, but always check the serial plate.

## 7. User Information

### Food Handling and Hot Food Equipment

These hot tables are for short-term holding and display of precooked hot foods. They are not intended to cool or reheat food. The temperature of the food should be approximately 160°F when first put into the hot table.

These hot tables are best suited when used in a cafeteria type application where the food is held and served rapidly, within a few hours. Any attempt to use the hot table to display large amounts of food for long periods of time will result in dehydrated, overcooked and unsafe food. The quality of food will progressively worsen as the length of time increases.

The deterioration of product quality is a function of time and temperature. All products are affected even though in a gravy or other liquid. They may appear to withstand the temperature better than "dry" foods such as fried chicken but this is not necessarily true. ALL foods will continue to be affected by prolonged exposure to elevated temperatures.

The following guidelines are provided only as a general guide for the use of this equipment. The local health agency for your area can provide specific temperature requirements.

Critical attention must be given to the heat controls for these hot tables. Both the upper and lower heat controls must be adjusted to achieve proper food temperatures. Hot foods should be held at a minimum temperature of at least 140°F (60°C) according to 1995 FDA Food Code. However, increasing the temperature too high will also cause the food to overcook, dry out, lose its flavor, texture and color. Food held for prolonged periods at high temperatures will also lose some of their nutritional value.

Different foods will require different control settings. The type of food, the quantities of food and length of time that it is to remain in the hot table must be considered when establishing control settings. Therefore, it must be the user's responsibility to establish the correct control settings to maintain the food at the safest, tastiest and most saleable condition.

***FOOD TEMPERATURES CAN BE  
ACCURATELY DETERMINED ONLY  
THROUGH THE USE OF FOOD  
THERMOMETERS!***

#### Important Operation Tips:

- Preheat case 30 minutes before loading product using higher settings.
- Never place food directly into warmer. Always use an inset and pan.
- Never pour water into a dry preheated warmer. This may damage the unit. Always pour water into

warmer BEFORE preheating. Always use water in case wells, as it provides even heat and humidity.

- Too much water or too much heat will cause excessive condensation on the front glass, decreasing visibility.
- Make sure all pans are in the well units no matter the configuration.
- Using thermometer, check product before loading in case (150°-160°F).
- Always use warmer in wet operation when warming thick food items.
- Stir thick foods such as chili, fudge and chowders often to keep foods uniformly heated and prevent scorching.
- At start, set wells to "7", and overhead heat to "5". After loading, recheck temperature every 1/ hour to see that unit is operating properly. Adjust the thermostat (a higher number for hotter and a lower number for cooler) to maintain product temperature of 140°F+ (60°C) minimum. The setting will depend on the type of product being displayed and how much there is in the well. Be sure to test product temperature with a thermometer frequently for good product maintenance.
- Keep cover(s) on insets to maintain food quality and temperature.
- Food must always be placed into a display pan over the well, never directly into the well.
- Food should not be stacked above the top of the pan. Food above the top of the pan will dry out rapidly.
- Food juice or gravy should be stirred frequently and any meats should be basted with the gravy. Stir and rotate foods as needed. Wipe up spills immediately for eye appeal now, and easier cleaning later.
- Food should be rotated periodically from the bottom to top.
- If practical, the food should be covered during slow sale periods to reduce dehydration.
- At end of the day, remove product and let case cool. Then clean with soap and water (use oven cleaner on the difficult spots). Polish and clean glass with a good glass cleaner.

#### Controls

The controls to regulate the temperature of the well heaters, griddle, and the overhead heat are located at the rear of the case.

**Note:** **Condensation will accumulate on the front glass if the hot well setting is greater than 7.**

## User Information (Cont'd)

### Hot Well/Soup Well Operating Instructions

Each hot unit has an individual heater with a separate control. These are thermostatically controlled with an indicator light showing when the heater has cycled on and is heating. The light above each control knob indicates when the well heater is heating.

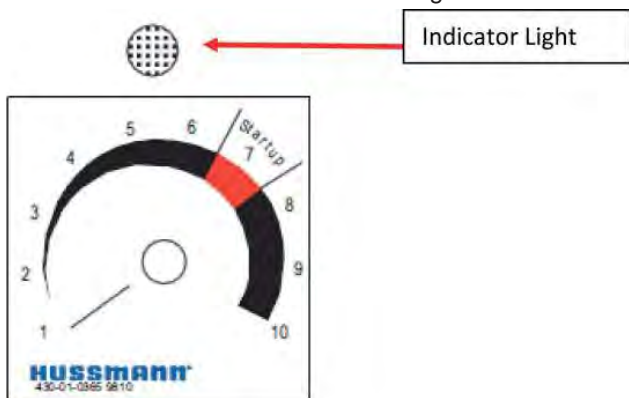

These units are for short-term holding and display of precooked hot foods. They are not intended to cool or reheat food. The temperature of the food entering the display should be approximately 160°F when first inserted.

Any attempt to use the hot unit to display large amounts of food or soup for long periods of time will result in dehydrated, overcooked and unsafe food. The quality of the food will progressively worsen as the length of time increases.

The deterioration of product quality is a function of time and temperature. All products are affected even though in gravy or other liquid. They may appear to withstand the temperature better than “dry” foods such as fried chicken but this is not necessarily true. All foods will continue to be affected by prolonged exposure to elevated temperatures.

The following guidelines are provided only as a general guide for the use of this equipment. The local health agency for your area can provide specific temperature requirements.

Critical attention must be given to the heat controls for these hot tables/soup bars. Both the upper and lower heat controls (soup only require lower control) must be adjusted to achieve proper food temperatures. Hot foods should be held at a constant temperature of at least 140°F (60°C) (minimum FDA requirements to prevent spoiling). However, increasing the temperature too high will also cause the food to overcook, dry out, lose its flavor, texture and color. Food held for prolonged periods at high temperatures will also lose some of their nutritional value.

Different foods require different control settings. The type of food, the quantities of food and length of time that it is to remain in the hot table must be considered when establishing control settings. Therefore, it must be the user’s responsibility to establish the correct control settings to maintain the food at the safest, tastiest and saleable condition.

## User Information (Cont'd)

Startup:

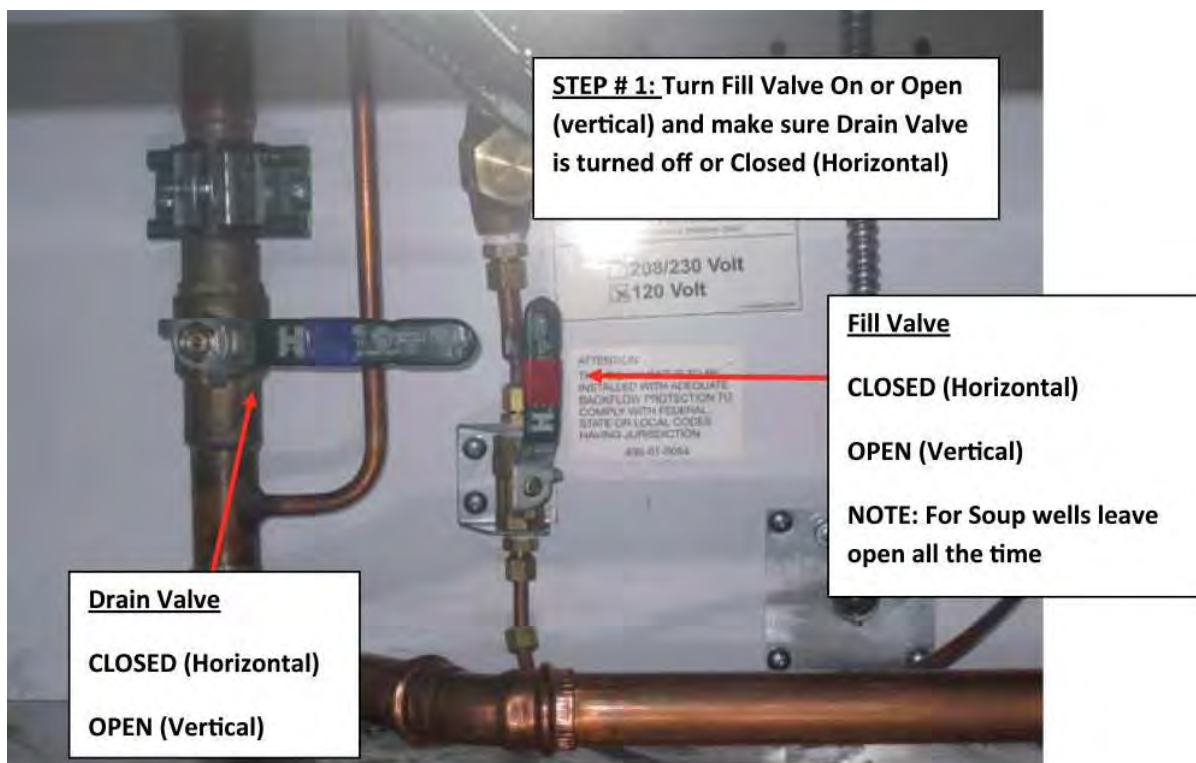

### To fill the well:

- Turn the fill valve to open position.
- Close the drain valve.

### To drain the well:

- Turn the fill valve to the closed position.
- Open the drain valve.

## User Information (Cont'd)

**STEP # 2:** Turn Water Fill Switch On and leave on during operation.

**STEP # 3:** After wells have filled and water has stopped, turn "ON" switch on so that red light appears on top portion of switch

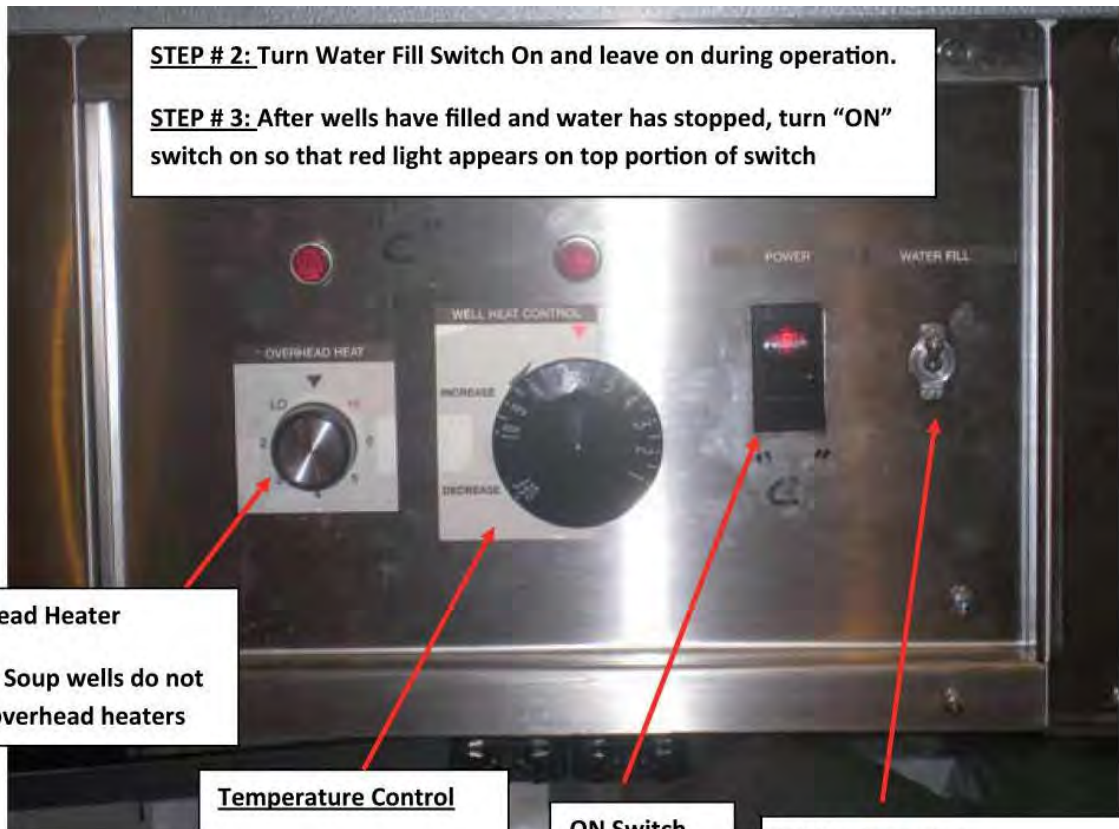

**Overhead Heater**

NOTE: Soup wells do not have overhead heaters

**Temperature Control**

Suggested: "7"

**ON Switch**

**Water Fill Switch**

Turn on for operation, must stay on

NOTE: Soup wells do not have a switch there is an automatic fill

**Operation:**

- Turn the water fill switch on.
- After wells have filled turn "ON" switch on.
- Set temperature control to '7" setting. Adjust as necessary.
- Adjust overhead heater as necessary.

**Shutting down:**

- Turn "ON" switch off.
- Turn water fill switch off.
- Close fill valve.
- Open drain valve.
- Once the water is drained, close the drain valve.

## User Information (Cont'd)

### Overhead Heating System

Overhead heaters and fluorescent lights are located above each well to provide both top heat and illumination.

To obtain the proper food temperatures, the well heater and overhead heater must be adjusted. Maximum limits should be avoided to prevent overcooking or drying out of food.

**Note:** Soup Wells do not have overhead heaters.

### Food temperatures can be accurately determined only through the use of food thermometers!

Important Food Handling Tips:

1. Preheat case 30 minutes before loading product.
2. Never place food directly into the warmer. Always use an inset.
3. Food must be displayed in a single layer, in contact with the heat source at all times.
4. Using thermometer, check product before loading in case (150°-160°).
5. At start, set control to "7". After loading, recheck temperature every ½ hour to see that unit is operating properly. Adjust the temperature to maintain a product temperature of 140°F (60°C) and above. The setting will depend on the type and quantity of product being displayed. Be sure to test product temperature with a thermometer frequently for good product maintenance.
6. Food should be rotated periodically.
7. At the end of the day, remove product and let case cool. Then clean with soap and water.

### Care and Cleaning

Long life and satisfactory performance of any equipment is dependent upon the care it receives. With this in mind, all of the exposed work surfaces of these hot tables have been made entirely of easy to clean stainless steel.

Stainless steel is one of the easiest materials to clean and keep clean. Normally it is just a matter of wiping spills off the surface when they happen followed by a thorough cleaning with soap and water at the end of the day. Frequent and regular cleaning will prevent the buildup of baked on difficult to remove spills. Many types of cleansers are available and safe to use on stainless steel. However, ordinary steel wool and steel brushes should not be used. Small particles of the steel may become imbedded into the stainless steel surfaces that will eventually rust and stain.

### General Cleaning Rules

1. Allow surfaces to cool before handling.
2. Clean frequently and regularly.
3. Rinse thoroughly after cleaning.
4. Remove surface spills immediately with a damp cloth.

### Cleaning Cases

1. Turn temperature control knob to OFF position.
2. Remove insets and adapters (if used).
3. Allow unit to cool completely.
4. Drain water from wells using large hand valve. It is not necessary to read just the water level plate.
5. Wipe entire unit with clean cloth and mild detergent.

The EXTERIOR surfaces of these hot tables must be cleaned with a mild detergent and warm water to protect and maintain their attractive finish. Never use abrasive cleaners or scouring pads.

### TO REMOVE "BAKED-ON" SPLATTER, GREASE OR LIGHT DISCOLORATION TO STAINLESS STEEL

STEELCLEANSING AGENT	METHOD OF APPLICATION
Grade F Italian Pumice	Scour or rub with damp cloth
Liquid NuSteel	Scour with small amount on dry cloth
Paste NuSteel	On Dry Cloth
Household Cleansers	Rub with damp cloth
Coopers S.S. Cleaner	
Allen S.S Polish	

## User Information (Cont'd)

### To Remove Heat Tint Or Heavy Discoloration

CLEANSING AGENT	METHOD OF APPLICATION
Allen Stainless Steel Polish	Small amount on damp cloth
Birdsall "Staybright"	Rub with damp cloth
Wyandotte	
Bab-O	
Nusteel	Rub with stainless steel wool

### Stainless Steel Cleaning and Care

There are three basic things, which can break down your stainless steel's passivity layer and allow corrosion.

#### 1. Mechanical Abrasion

Mechanical Abrasion means those things that will scratch the steel's surface. Steel Pads, wire Brushes, and Scrapers are prime examples.

#### 2. Water

Water comes out of our tap in varying degrees of hardness. Depending on what part of the country you live in, you may have hard or soft water. Hard water may leave spots. Also, when heated, hard water leaves deposits behind that if left to sit, will break down the passive layer and rust your stainless steel. Other deposits from food preparation and service must be properly removed.

#### 3. Chlorides

Chlorides are found nearly everywhere. They are in water, food and table salt. One of the worst perpetrators of chlorides can come from household and industrial cleaners.

Don't Despair! Here are a few steps that can help prevent stainless steel rust.

#### 1. Use the Proper Tools

When cleaning your stainless steel products, take care to use non-abrasive tools. Soft Clothes and plastic scouring pads will NOT harm the steel's passive layer. Stainless steel pads can also be used but the scrubbing motion must be in the same direction of the manufacturer's polishing marks.

#### 2. Clean With the Polish Lines

Some stainless steels come with visible polishing lines or "grain". When visible lines are present, you should ALWAYS scrub in a motion that is parallel to them. When the grain cannot be seen, play it safe and use a soft cloth or plastic scouring pad.

#### 3. Use Alkaline, Alkaline Chlorinated or Non-chloride Containing Cleaners

While many traditional cleaners are loaded with chlorides, the industry is providing an ever increasing choice of non-chloride cleaners. If you are not sure of your cleaner's chloride content contact your cleaner supplier. If they tell you that your present cleaner contains chlorides, ask for an alternative. Also, avoid cleaners containing quaternary salts as they also can attack stainless steel & cause pitting and rusting.

#### 4. Treat your Water

Though this is not always practical, softening hard water can do much to reduce deposits. There are certain filters that can be installed to remove distasteful and corrosive elements. If you are not sure of the proper water treatment, call a treatment specialist.

#### 5. Keep your Food Equipment Clean

Use alkaline or non-chlorinated cleaners at recommended strength. Clean frequently to avoid build-up of hard, stubborn stains. If you boil water in your stainless steel equipment, remember the single most likely cause of damage is chlorides in the water. Heating cleaners that contain chlorides has a similar effect.

#### 6. RINSE, RINSE, RINSE

If chlorinated cleaners are used you must rinse, rinse, rinse and wipe dry immediately. The sooner you wipe off standing water, especially when sit contains cleaning agents, the better. After wiping the equipment down, allow it to air dry for the oxygen helps maintain the stainless steel's passivity film.

#### 7. Never Use Hydrochloric Acid (Muriatic Acid) on Stainless Steel

#### 8. Regularly Restore/Passivate Stainless Steel

### To Remove Lime Deposits

Use a de-liming agent so deposits do not build up. If your area's water has a high mineral content, it may be wise to install a cartridge type filtration system to minimize buildup.

**DO NOT USE ANY HIGHLY CAUSTIC CLEANERS ON WARMERS. USE OF THESE MAY CAUSE DAMAGE OR CORROSION TO THE UNIT.**

**Do not allow ammonia to stand in warmer. Doing so may cause damage or corrosion.**

## User Information (Cont'd)



### IMPORTANT INFORMATION

**Rinse unit thoroughly with vinegar and water. The vinegar will neutralize any detergent residue.**

Close drain valve and allow water to refill. Due to the small diameter feed line, this water fills at an extremely slow rate, so it is advisable to begin refilling immediately after cleaning - a number of hours before heating and loading with product. Water will automatically fill to the same level it was when it was drained.

### Plexiglass and Acrylic Care

Clean with plenty of nonabrasive soap (or detergent) and lukewarm water, using the bare hand to feel and dislodge any caked-on dirt. A soft, grit-free cloth, sponge, or chamois may be used, but only as a means of carrying the water to the plastic. Dry with a clean damp chamois or clean soft cloth such as cotton flannel. Hard, rough cloths paper towels will scratch the acrylic, and should not be used.

### CAUTION

#### CLEANING PRECAUTIONS

##### When cleaning:

- Do not use high pressure water hoses
- Do not introduce water faster than waste outlet can drain
- NEVER INTRODUCE WATER ON SELF CONTAINED UNIT WITH AN EVAPORATOR PAN
- NEVER USE A CLEANING OR SANITIZING SOLUTION THAT HAS AN OIL BASE (these will dissolve the butyl sealants) or an AMMONIA BASE (this will corrode the copper components of the case)
- TO PRESERVE THE ATTRACTIVE FINISH:
- DO USE WATER AND A MILD DETERGENT FOR THE EXTERIOR ONLY
- DO NOT USE A CHLORANITED CLEANER ON ANY SURFACE
- DO NOT USE ABRASIVES OR STEEL WOOL SCOURING PADS (these will mar the finish)

### Waxing

If after removing dirt and grease, the acrylic can be waxed with a good grade commercial wax. This will improve the appearance of the surface by filling in most minor scratches. Wax should be applied in a thin even coat, and brought to a high polish by rubbing lightly with a dry clean soft cloth, such as a cotton flannel. Excessive rubbing may cause scratching and/or buildup an electrostatic charge, which attracts dust and dirt to the surface. Blotting with a clean damp cloth is recommended to remove charge.

### Antistatic Coatings

For acrylic used indoors, antistatic coatings successfully prevent the accumulation of electrostatic charge for periods of several months, if the surface is not washed or wiped down with a wet cloth. Between applications of the antistatic coatings, the parts need only be dusted with a soft clean cloth to maintain a good appearance. In use, liquid antistatic coatings should be applied in a very thin even coat. If beads appear as it is applied, the coat is too thick and the excess should be removed with another cloth. Allow the coating to dry, then bring to a high gloss with a soft cloth.

### Non-Glare Glass

The high optical clarity of this glass is possible due to special coatings on the glass surface itself. To preserve this coating and the optical clarity, keep the glass clean.

Water is the only solution recommended to be used to clean the non-glare glass. The damage to the glass from improper, caustic solutions is irreparable.

In addition to cleaning the glass with the recommended product, there are precautions that should be taken when working and cleaning the inside of the case.

- When cleaning the inside of the cases, we recommend that the glass be fully opened and covered to prevent solutions from splashing onto the glass and ruining the coating on the inside.

## 8. Maintenance

### Electrical Precautions



**DANGER**

**BEFORE SERVICING**  
**ALWAYS DISCONNECT ELECTRICAL**  
**POWER AT THE MAIN DISCONNECT**  
**WHEN SERVICING OR REPLACING ANY**  
**ELECTRICAL COMPONENT.**  
This includes (but not limited to) Fans, Heaters  
Thermostats, and Lights.

### Replacing Overhead Heat Elements

Tubular heating units are designed to last through many hours of use. Should there be a need to replace one, unclip the rod and replace. The tubular heating unit specifications are printed on the unit itself.



**DANGER**

**Tubular Heating Units**  
**are EXTREMELY HOT**  
**Never touch until the case has**  
**had ample time to cool down**

### Tips and Troubleshooting

Before calling for service if something seems wrong, check the following:

1. Check electrical power supply to the equipment for connection.
2. Check fixture loading. Overstocking case will affect its proper operation.



**IMPORTANT**  
**INFORMATION**

**FOR PROMPT SERVICE**  
**When Contacting the Factory regarding problems.**  
**Be sure to have the Case MODEL and**  
**SERIAL NUMBER Handy. This Information**  
**is on a plate located on the case itself.**

# 9. Specification



SINGLE DECK HOT CASE

HUSSMANN - Q-HC, Q-HV, Q-HC-SS, Q-HS, Q-HS-SS (CHINO)

####

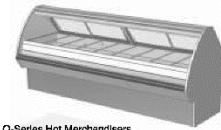
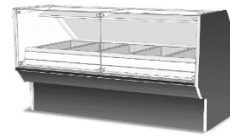
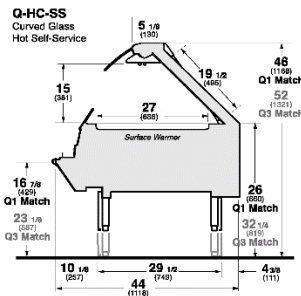
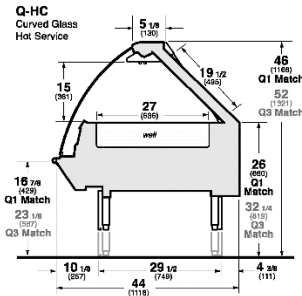

QHC, QHS Q-Series Hot Merchandisers

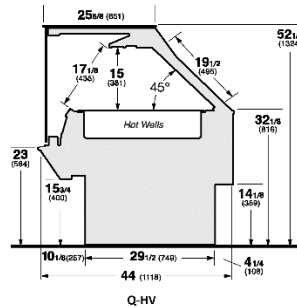
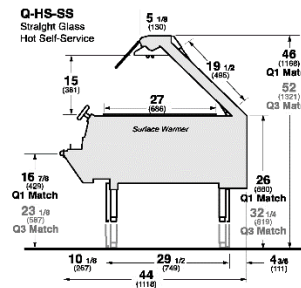
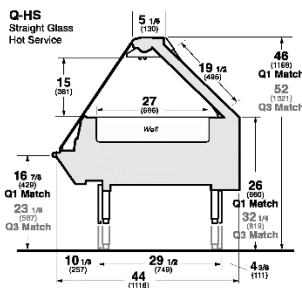
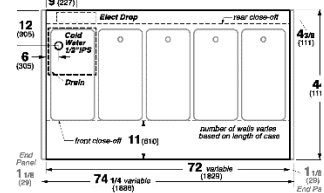

QH-SS Q-Series Hot Merchandisers

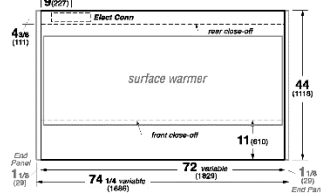

SERVICE CASE W/WELLS

SELF-SERVICE CASE W/SURFACE WARMERS

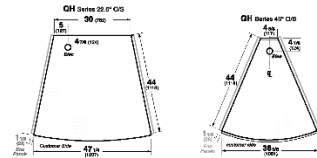

**ELECTRICAL DATA:**

SURFACE WARMER	VOLTS	PH	HZ	TOTAL WELLS	WATTS	AMPS	FANS / CASE	TOTAL FANS		WIRES **	
								AMPS	WATTS		
4'	HOT	240	1	60	NA	3048	12.7	2	0.28	24	4
5'	HOT	240	3	60	NA	4350	18.1	3	0.42	36	5
6'	HOT	240	3	60	NA	4359	18.2	3	0.42	36	5
8'	HOT	240	3	60	NA	5812	24.2	4	0.56	48	5
10'	HOT	240	3	60	NA	8700	36.2	6	0.84	72	5
12'	HOT	240	3	60	NA	8718	36.3	6	0.84	72	5
22.5° O/S	HOT	240	1	60	NA	2313	9.64	N/A	N/A	N/A	4
45° O/S	HOT	240	TBD	60	NA	TBD	TBD	TBD	TBD	TBD	TBD

CANOPY LIGHTS T-5		OPTIONAL LEDGE LIGHTS T-5		TOTAL LIGHTS T-5	
AMPS	WATTS	AMPS	WATTS	AMPS	WATTS
0.39	42	0.26	28	0.65	70
0.52	56	0.32	35	0.84	91
0.65	70	0.39	42	1.04	112
0.78	84	0.52	56	1.30	140
1.04	112	0.65	70	1.69	182
1.17	126	0.78	84	1.95	210
0.26	28	TBD	TBD	TBD	TBD
TBD	TBD	TBD	TBD	TBD	TBD

LEGEND		
N/A -	AVAILABLE	
TBD -	DETERMINED	
SBO -	SUPPLIED BY OTHERS	
EXTERNAL END PANEL WIDTH KEY		
# OF END PNL'S	PNL WIDTH (IN.)	PNL LENGTH (IN.)
1	1.125	1.125
2	1.125	2.25

HOT WELLS	VOLTS	PH	HZ	TOTAL WELLS	WATTS	AMPS	FANS / CASE	TOTAL FANS		WIRES **	
								AMPS	WATTS		
4'	HOT	240	3	60	3	3600	15.0	2	0.28	24	5
5'	HOT	240	3	60	4	4900	20.0	3	0.42	36	5
6'	HOT	240	3	60	5	6000	25.0	3	0.42	36	5
8'	HOT	240	3	60	6	7200	30.0	4	0.56	48	5
10'	HOT	240	3	60	8	9800	40.0	6	0.84	72	5
12'	HOT	240	3	60	9	10800	45.0	6	0.84	72	5

CANOPY LIGHTS T-5		OPTIONAL LEDGE LIGHTS T-5		TOTAL LIGHTS T-5	
AMPS	WATTS	AMPS	WATTS	AMPS	WATTS
0.39	42	0.26	28	0.65	70
0.52	56	0.32	35	0.84	91
0.65	70	0.39	42	1.04	112
0.78	84	0.52	56	1.30	140
1.04	112	0.65	70	1.69	182
1.17	126	0.78	84	1.95	210

COMBINATION WARMERS / WELLS	VOLTS	PH	HZ	TOTAL WELLS	WATTS	AMPS	FANS / CASE	TOTAL FANS		WIRES **	
								AMPS	WATTS		
8'	HOT	240	3	60	TBD	TBD	TBD	4	0.56	48	5
10'	HOT	240	3	60	TBD	TBD	TBD	6	0.84	72	5
12'	HOT	240	3	60	TBD	TBD	TBD	6	0.84	72	5

CANOPY LIGHTS		OPTIONAL LEDGE LIGHTS		TOTAL LIGHTS	
AMPS	WATTS	AMPS	WATTS	AMPS	WATTS
0.78	84	0.52	56	1.30	140
1.04	112	0.65	70	1.69	182
1.17	126	0.78	84	1.95	210

\*\* INCLUDES GROUND WIRE

**OPTIONS/NOTES:**

- 1) NOTE: CASES MUST BE GROUNDED
- 2) NOTE: LED LIGHTS ARE NOT AVAILABLE ON HOT CASES AT THIS TIME.

# Specification Sheets



**SINGLE DECK HOT CASE**  
 HUSSMANN - Q-HC, Q-HV, Q-HC-SS, Q-HS, Q-HS-SS 208V (CHINO)

8/3/2021

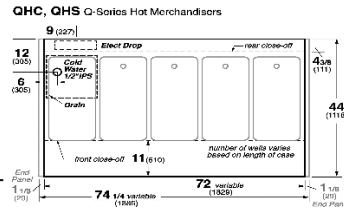
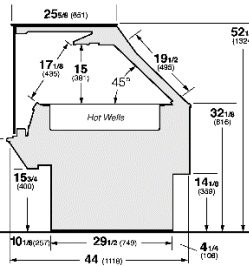
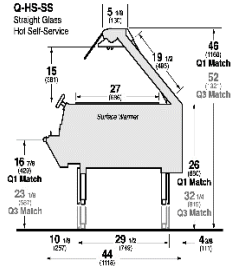
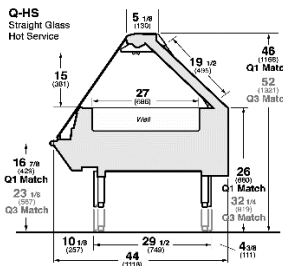
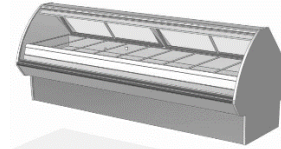
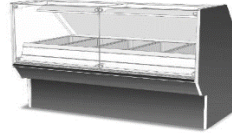
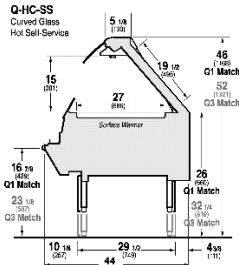
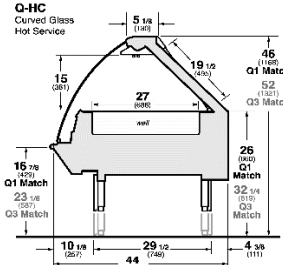

SERVICE CASE W/WELLS

SELF-SERVICE CASE W/SURFACE WARMERS

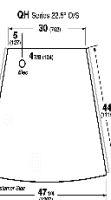

Q-HV

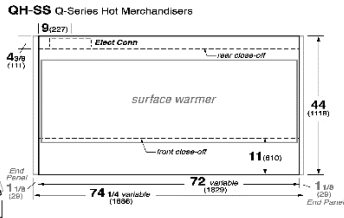
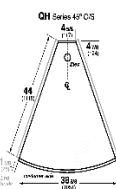

**ELECTRICAL DATA:**

SURFACE WARMER	VOLTS	PH	HZ	TOTAL WELLS	WATTS	L1	L2	L3	FANS / CASE	WIRES **	OPTIONAL LEDGE LIGHTS T-5 *		
											AMPS	WATTS	
4'	HOT	208	1	60	NA	2787	13.4	12.8	NA	2	4	0.26	28
5'	HOT	208	1	60	NA	3224	15.5	14.6	NA	3	4	0.32	35
6'	HOT	208	3	60	NA	5284	14.7	14.1	15.2	3	5	0.39	42
8'	HOT	208	3	60	NA	3062	7.7	6.5	11.3	4	5	0.52	56
10'	HOT	208	3	60	NA	5068	17.4	9	15.8	6	5	0.65	70
12'	HOT	208	3	60	NA	7805	23.2	20.9	20.9	6	5	0.78	84
22.5\"/>													
45\"/>													

LEGEND		
NA	NOT AVAILABLE	
TBD	TO BE DETERMINED	
CKT	CIRCUIT	
SBO	SUPPLIED BY OTHERS	
EXTERNAL END PANEL WIDTH KEY		
# OF END PNLS	END PNL WIDTH (IN.)	TOTAL ADDED LENGTH (IN.)
1	1.125	1.125
2	1.125	2.25

HOT WELLS	VOLTS	PH	HZ	TOTAL WELLS	WATTS	L1	L2	L3	FANS / CASE	WIRES **	OPTIONAL LEDGE LIGHTS T-5 *		
											AMPS	WATTS	
4'	HOT	208	1	60	3	5325	26.6	24.9	NA	2	4	0.26	28
5'	HOT	208	3	60	4	8257	23.6	27.8	17.4	3	5	0.32	35
6'	HOT	208	3	60	5	10063	30.6	29.5	23.7	3	5	0.39	42
8' CKT 1	HOT	208	3	60	6	8514	24.5	23.2	23.2	4	5	0.52	56
CKT 2	HOT	208	3	60	NA	3602	7.5	15	7.5	NA	5	NA	NA
10' CKT 1	HOT	208	3	60	8	8982	23.7	26.5	22.1	6	5	0.65	70
CKT 2	HOT	208	3	60	NA	4323	9.0	18	9.0	NA	5	NA	NA
12' CKT 1	HOT	208	3	60	6	8998	26.2	23.2	23.2	6	5	0.78	84
CKT 2	HOT	208	3	60	3	9583	26.6	26.6	26.6	NA	5	0.78	84

COMBINATION WARMERS / WELLS	VOLTS	PH	HZ	TOTAL WELLS	WATTS	L1	L2	L3	FANS / CASE	WIRES **	OPTIONAL LEDGE LIGHTS T-5 *	
											AMPS	WATTS
8'	HOT	208	3	60	TBD	TBD	TBD	TBD	4	5	0.52	56
10'	HOT	208	3	60	TBD	TBD	TBD	TBD	6	5	0.65	70
12'	HOT	208	3	60	TBD	TBD	TBD	TBD	6	5	0.78	84

\* LIGHTS AND FANS INCLUDED IN TOTAL LOADS  
 \*\* INCLUDES GROUND WIRE

**OPTIONS/NOTES:**

- NOTE: CASES MUST BE GROUNDED
- NOTE: LED LIGHTS ARE NOT AVAILABLE ON HOT CASES AT THIS TIME.

## 10. Electrical Wiring Diagrams

Q-HC-4SV-P	Q-HC-4 W/GRIDDLE	4'	W6600038
Q-HC-4-SV	Q-H 42" SW, CAL ROD TOP 208V	4'	W6600641
Q-HC-4SV-W	QH-4' W/3 INDIVIDUAL WELLS 43D (208V)	4'	W6600079
Q-HC-4SV-W	QH-4' W/3 INDIVIDUAL WELLS 43DA (208V)	4'	W6600567
Q-HC-4-SV-W	QH-4' W/3 GANGED WELLS (208V)	4'	W6600646
Q-HC-5-SV-W	Q-H W/4 WELL INDIVIDUAL WARMERS	5'	W6600153
Q-HC-5-SV-W	Q-H W/4 WELL GANGED WARMERS	5'	W6600919
Q-HC-5-SS-P	Q-H W/54" HATCO SW	5'	W6600458
Q-HC-5-HOT	Q-HOT 4 WELL CALROD TOP 208V	5'	W6600815
Q-HC-6-SV-P	Q-H with Heater Pads (PREP)	6'	W6600087
Q-HC-6-SV-W-SW	Q-H W/3 WELLS & 24" SURFACE WARMER	6'	W6600148
Q-HS-6-SV-W	Q-H SW DECK, CAL ROD TOP	6'	W6600902
Q-HC-6-SV-W	Q-H WITH 5 INDIVIDUAL WARMERS	6'	W6600084
Q-HC-6	Q-HV-6 5-WELL GANGED 20" CAL RODS	6'	W6600536
Q-HC-6	Q-HV-6 5-WELL GANGED 20" CAL RODS	6'	W6600469
Q-HC-6-W	Q-HC-6. 60-S SW, CAL RODS 208V	6'	W6600723
Q-HC-6-SV-W	Q-H WITH 5 INDIVIDUAL WARMERS 208V	6'	W6600574

## Electrical Wiring Diagrams (Cont'd)

Q-HC-8-SV-W	Q-H WITH HATCO SURFACE WARMERS	8'	W6600182
Q-HC-8SV-P	Q-H with Heater Pads (PREP)	8'	W1750050
Q-HC-8-SS-G	Q-H with Heater Pads (SELF-SERVICE)	8'	W6600021
Q-HC-8SV-W	Q-H WITH (6) INDIVIDUAL WARMERS	8'	W6600023
Q-HC-8SV-W	Q-H WITH (6) INDIVIDUAL WELLS 240V	8'	W6600480
Q-HS-8	Q-H WITH (6) INDIVIDUAL WELLS 208V	8'	W6600686
Q-HS-8	Q-H WITH 6-WELL GANGED CAL ROD 208V	8'	W6600817
Q-HC-10-SS-P	Q-H W/2-54" HATCO SW	10'	W6600459
Q-HS-10	Q-H WITH (8) INDIVIDUAL WARMERS 208V	10'	W6600693
Q-HC-10-H	Q-H W/ 8 INDIVIDUAL WELLS DRY WELLS	10'	W6600694
Q-HS-10	Q-H W/2-54" SW, CAL ROD TOP 208V	10'	W6600733
Q-HS-10	Q-H W/2-4 WELL, CAL ROD TOP 208V	10'	W6600736
Q-HC-12-SV-W	Q-H WITH 9 INDIVIDUAL WARMERS	12'	W6600085
Q-HC-12-SV-W	Q-H WITH 10 INDIVIDUAL WARMERS	12'	W6600345
Q-HC-12-SV-W	Q-H WITH 9 INDIVIDUAL WARMERS	12'	W6600607
Q-HC-12SV-P	Q-H with Heater Pads & LED LEDGE LIGHTS	12'	W6600082

CIRCUIT #1

LOADING	208 V	240 V
L1	11.0	12.7
L2	10.5	12.1
L3		

3037W @ 208VAC  
3048W @ 240VAC

F21/T5-36"  
(2)125-03-1129 LIGHT CIRCUIT= 0.39A 42W

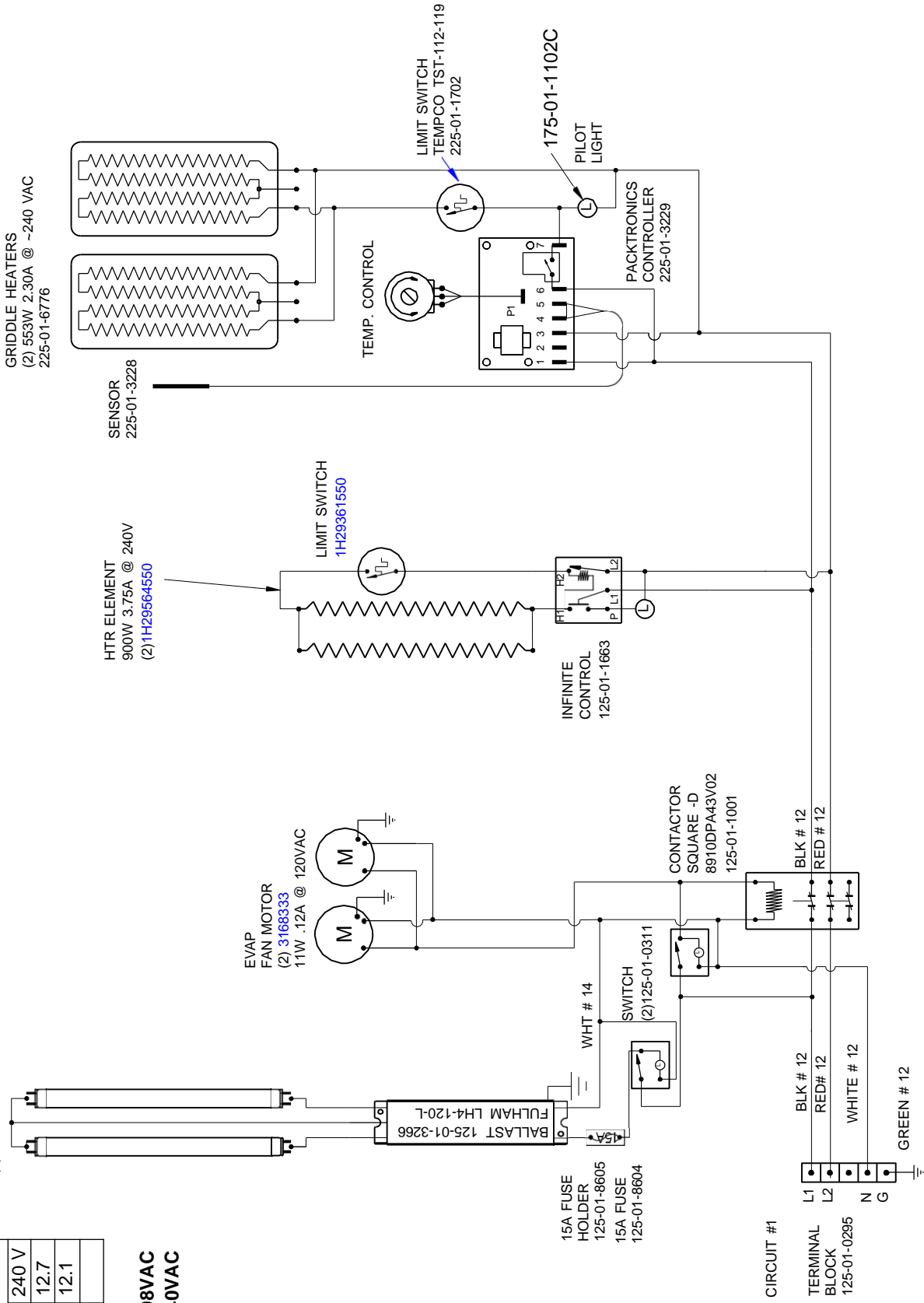

<b>HUSMANN</b> Husmann Corporation, Inc. 13770 Ramona Avenue Chino, CA 91710 (909)-599-4910 Lic.#: 644406		REVISIONS: # DESCRIPTION: B ECN-CAP-0003963 Revised Circuit Loads C ECN-COD-0017537 CHANGED TOP FAN	DRAWN BY: CRAIG BOOREY CHECKED BY: _____ DATE: 11/16/16 2/2/23	PROJECT TITLE: Q-H PRODUCTION ORDER #: _____ FILE LOCATION: CB	DRAWING #: W6600038 Q-HC-4SS-P W/TOP GRIDDLE PAGE 1 OF 1
---	--	--	---	--	--

**CIRCUIT #1**

LOADING
208 V
L1 134
L2 128
L3

278TW @ 208VAC

F21/175-36"  
12/125-03-1129 LIGHT CIRCUIT= 0.39A 42W

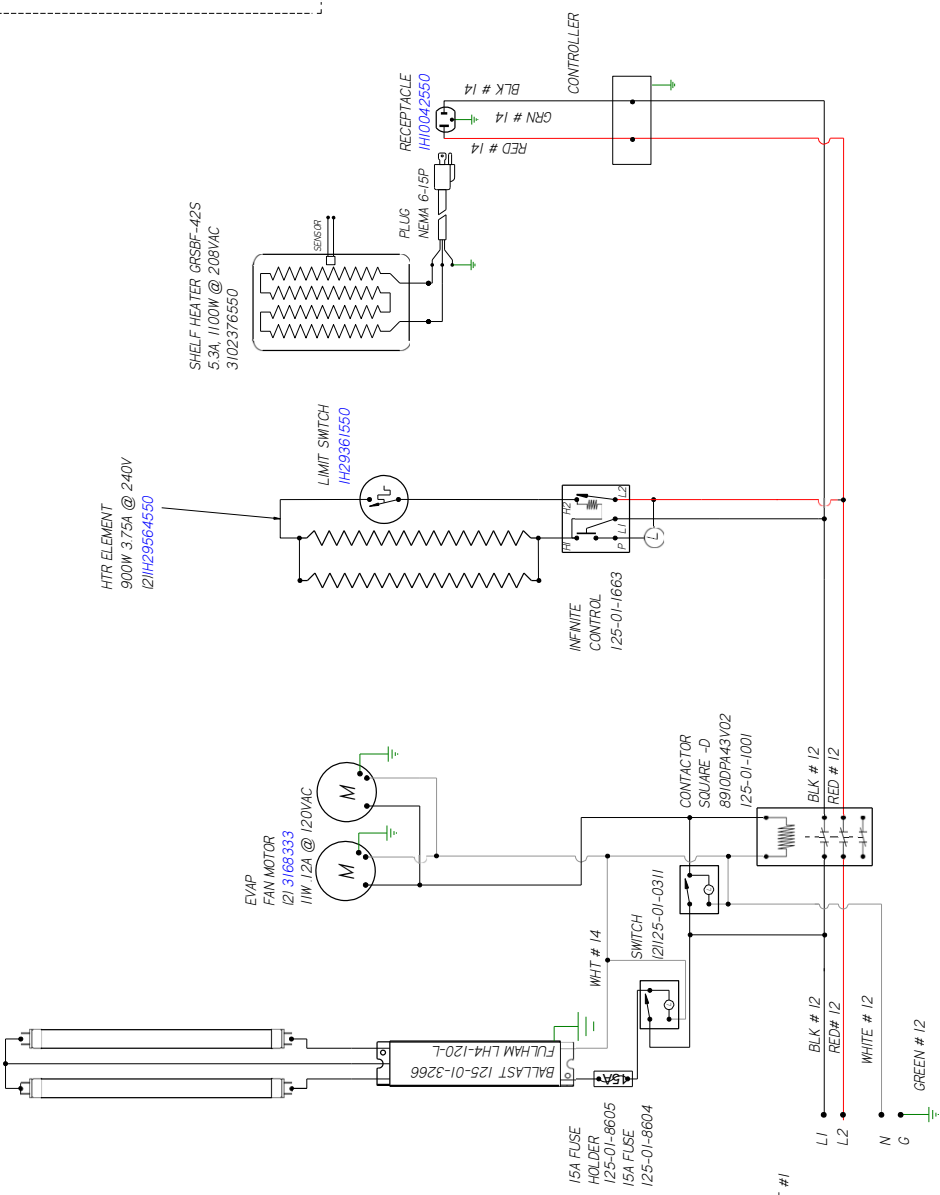

- NOTES:**
1. PRINTED DOCUMENT REQUIRED SETTING. ALL COLORS BLACK & WHITE
  2. CASE & ANY REMOVABLE PANEL WITH ELECTRICAL PARTS MUST BE GROUNDED.
  3. WHEN PASSING WIRES THROUGH METAL HOLES A GROMMET MUST BE USED

REV	ECN	DATE	REVISION DESCRIPTION	REV BY	CHKD BY	APPR BY
A	ECN-CAP-0020428	12-5-19	RELEASED TO PRODUCTION	CB	CB	CB
B	ECN-CAP-0017537	2-2-23	CHANGED TOP FAN	CB	CB	CB

**CIRCUIT # 2 optional**

LOADING
120 V
L1 150

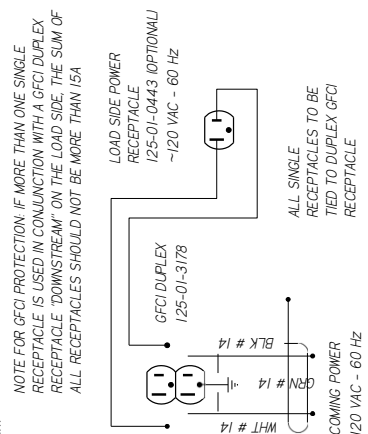

**HUSSMANN**  
DIAGRAM-Q-HC-4-SV

FACTORY 14GA WIRE  
FACTORY 10GA WIRE  
FIELD WIRE

DO NOT SCALE DRAWING  
SHEET 1 OF 1

UL COLOR CODES / ABBREVIATIONS  
 RED = RD  
 BLACK = BK  
 BLUE = BL  
 YELLOW = YL  
 GRAY = GR  
 WHITE = WT  
 GREEN = GN  
 BROWN = BN  
 ORANGE = OR  
 VIOLET = VT

LIGHT CIRCUIT= 0.39A 42W  
 F21/830 T5-36"  
 (2)125-03-1128

AIR SWEEP  
 FAN MOTOR  
 (2) 3168833  
 11W .12A @ 120VAC

(3) WARMERS  
 MODEL#HWBH-43D  
 208 VAC 6.0 AMPS  
 1650 WATT @240

HTR ELEMENT  
 900W 3.75A @ 240V  
 (2) 1H29564550

INFINITE  
 CONTROL  
 125-01-1663

LIMIT SWITCH  
 1H29361550

CIRCUIT #1	LOADING
	208V
L1	16.1
L2	15.8
L3	12.0

5276W @ 208VAC

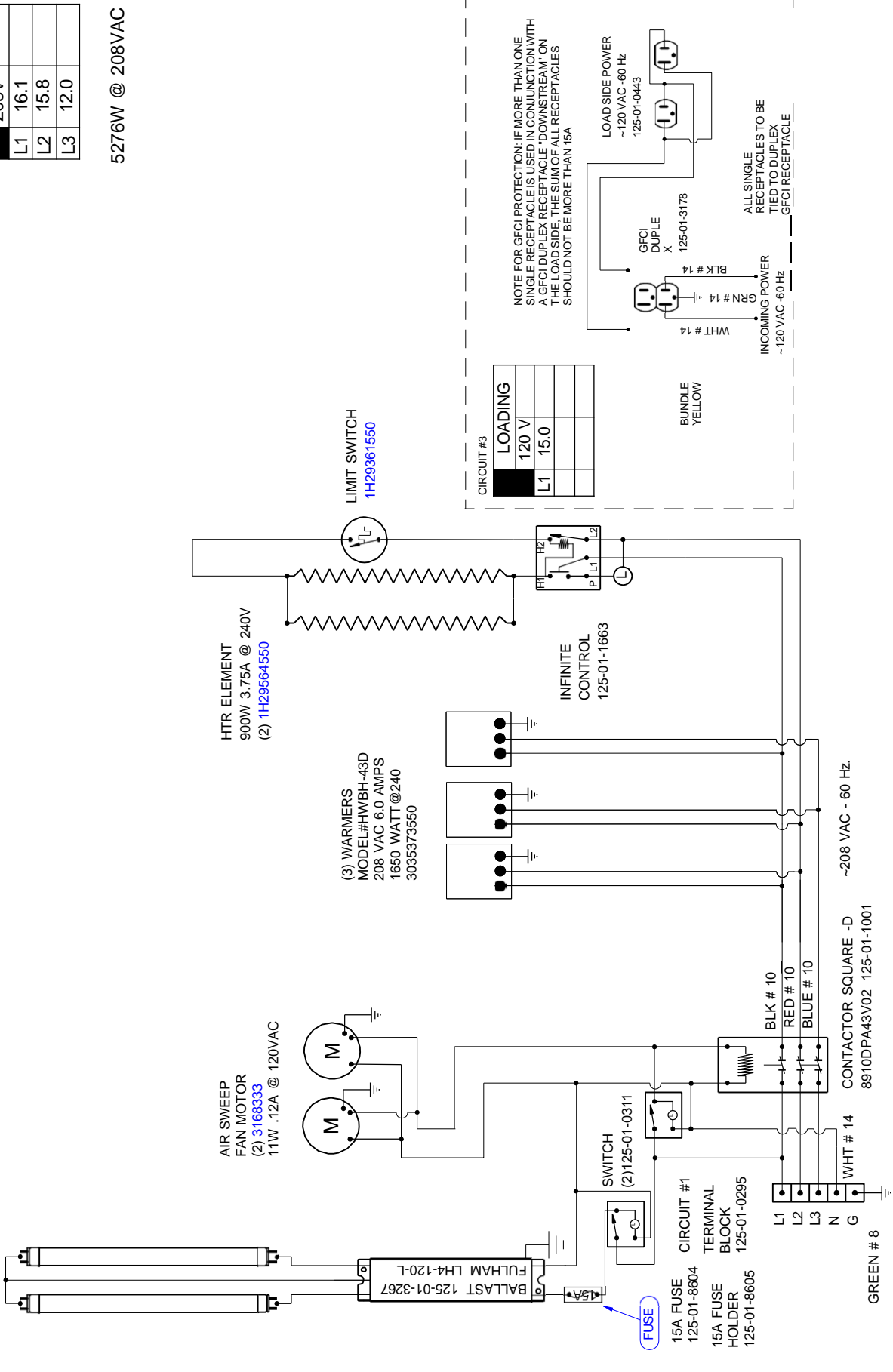

CIRCUIT #3	LOADING
	120 V
L1	15.0

BUNDLE  
 YELLOW

NOTE FOR GFCI PROTECTION: IF MORE THAN ONE  
 SINGLE RECEPTACLE IS USED IN CONJUNCTION WITH  
 A GFCI DUPLX RECEPTACLE "DOWNSTREAM" ON  
 THE LOAD SIDE, THE SUM OF ALL RECEPTACLES  
 SHOULD NOT BE MORE THAN 15A

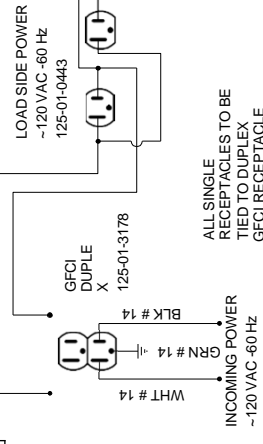

**HUSMANN**  
 Hussmann Corporation, Inc.  
 13770 Ramona Avenue  
 Chino, CA 91710 Lic.#: 644406  
 (909)-590-4910

REVISIONS:  

#	DESCRIPTION	DATE	BY
B	CN#720718 Changed Drawing Number in Titleblock	7/8/13	CB
C	ECN-CAP-0015600, Changed to 208V Wells	2/19/19	CB
D	ECN-COD-0017537, Changed Top Fan	2/2/23	CB

DRAWN BY: CRAIG BOOREY  
 CHECKED BY: QH  
 DATE: 5/2/13  
 PRODUCTION ORDER #: 524131  
 FILE LOCATION: Q-HC-4-SV-W

PROJECT TITLE: QH  
 DRAWING #: W6600079

GREEN # 8  
 CONTACTOR SQUARE -D  
 8910DPA43V02 125-01-1001

REVISION HISTORY			
REV	ECN	DATE	REVISION DESCRIPTION
B	ECN-CAP-0020429	12-11-19	ADDED DRY PART NUMBER
C	ECN-CAD-0017537	2-2-23	CHANGED TOP FAN

REV	CHKD BY	APPR BY
CB	CB	CB
CB	CB	CB

CIRCUIT #1	LOADING
L1	194
L2	191
L3	116

6016W @ 208VAC

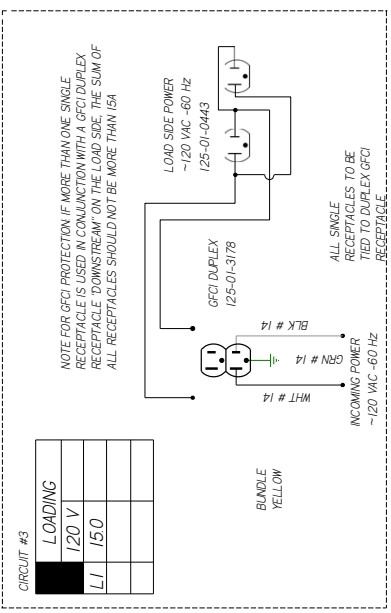
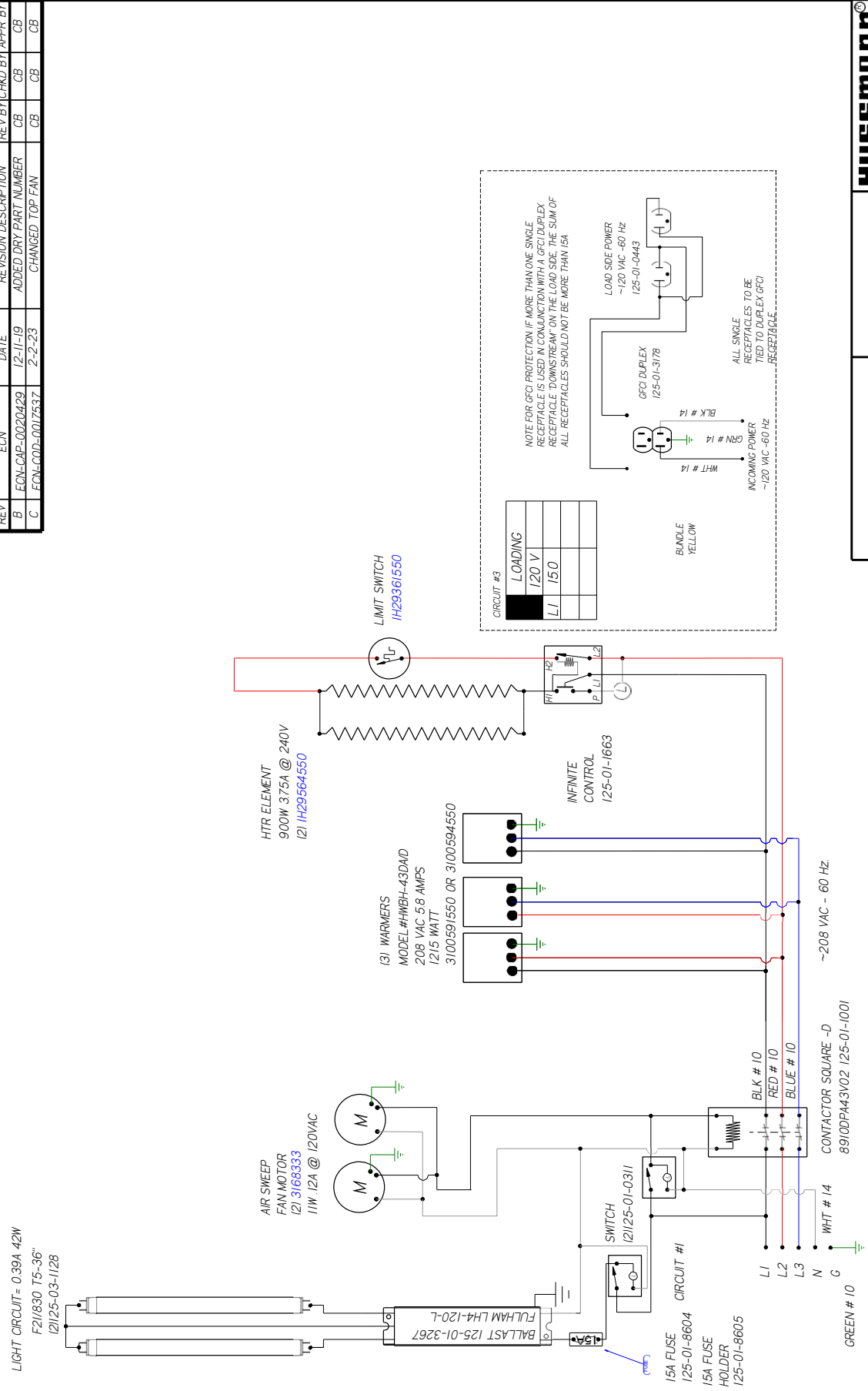

**HUSSMANN**  
**DIAGRAM-Q-HC-4-SV**  
**-W**

FACTORY 14GA WIRE  
 -FACTORY 10GA WIRE  
 -FIELD WIRE  
 -DO NOT SCALE DRAWING  
 SHEET 1 OF 1

**UL COLOR CODES / ABBREVIATIONS**

- RED = RD
- BLACK = BK
- BLUE = BL
- YELLOW = YL
- GRAY = GR
- WHITE = WT
- GREEN = GN
- BROWN = BN
- ORANGE = OR
- OR VIOLET = VT

- NOTES:**
1. PRINTED DOCUMENT REQUIRED SETTING. ALL COLORS BLACK & WHITE
  2. CASE & ANY REMOVABLE PANEL WITH ELECTRICAL PARTS MUST BE GROUNDED.
  3. WHEN PASSING WIRES THROUGH METAL HOLES A GROMMET MUST BE USED

CIRCUIT #1

CIRCUIT #1	LOADING
208V	
L1	256
L2	249

5325W @ 208VAC

LIGHT CIRCUIT= 0.39A 42W  
F21/830 T5-36"

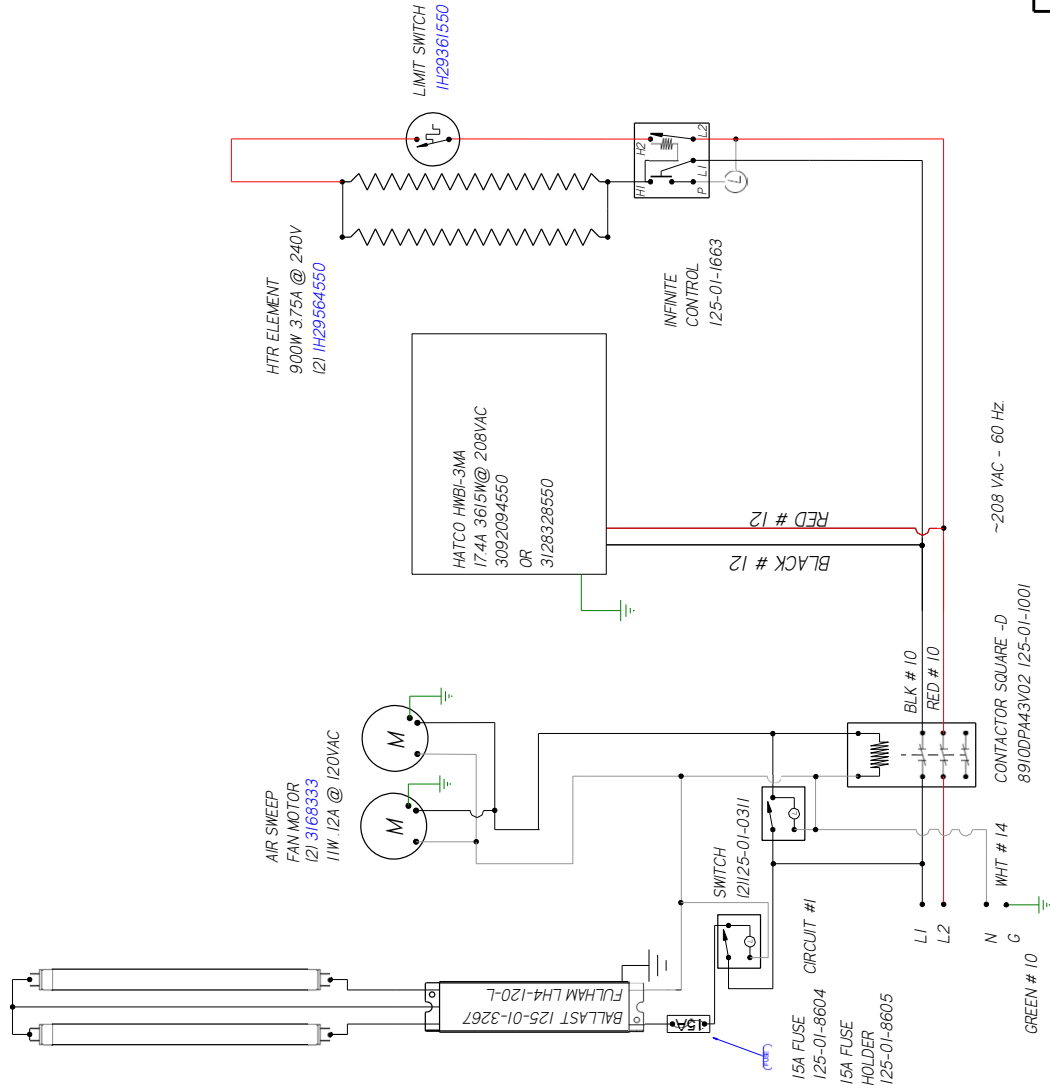

REVISION HISTORY			
REV	ECN	DATE	REVISION DESCRIPTION
B	ECN-000-0013662	5-19-21	ADD HOT WELL PART NUMBER
C	ECN-000-0017537	2-2-23	CHANGED TOP FAN

REV	BY	CHKD	BY	APPR	BY
CB	CB	CB	CB	CB	CB
CB	CB	CB	CB	CB	CB

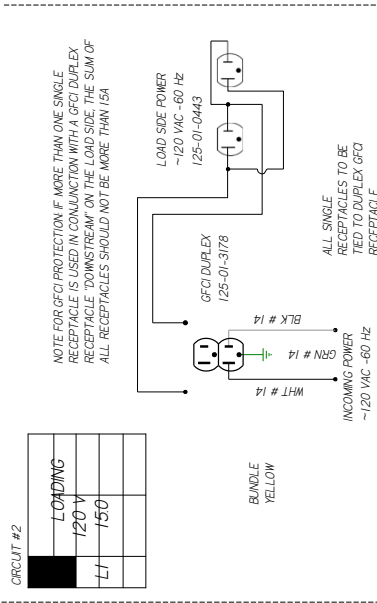

CIRCUIT #2

CIRCUIT #2	LOADING
120V	
L1	150

**HUSSMANN**  
DIAGRAM-Q-HC-4-SV  
-W

FACTORY 14GA WIRE  
FACTORY 10GA WIRE  
FIELD WIRE

DO NOT SCALE DRAWING  
SHEET 1 OF 1

UL COLOR CODES / ABBREVIATIONS  
 RED = RD  
 BLACK = BK  
 BLUE = BL  
 YELLOW = YL  
 GRAY = GR  
 WHITE = WT  
 GREEN = GN  
 BROWN = BN  
 ORANGE = OR  
 VIOLET = VT

- NOTES:
1. PRINTED DOCUMENT REQUIRED SETTING. ALL COLORS BLACK & WHITE
  2. CASE & ANY REMOVABLE PANEL WITH ELECTRICAL PARTS MUST BE GROUNDED.
  3. WHEN PASSING WIRES THROUGH METAL HOLES A GROMMET MUST BE USED

REV	ECN	DATE	REVISION DESCRIPTION	REV BY	CHKD BY	APPR BY
A	889896	2015/06/22	RELEASED TO PRODUCTION	CS	CS	CS
B	ECN:CAP-0044507	2018/09/07	ADDED GFCI	CS	CS	CS
C	ECN:GD-0077597	2023/02/02	CHANGED TOP FAN	CS	CS	CS

CIRCUIT #1	LOADING
206V	240
L1	150
L2	150
L3	150

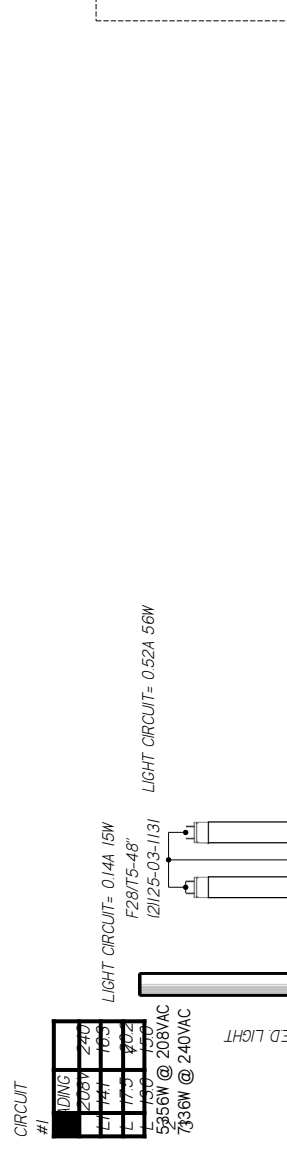

CIRCUIT # 2 (optional)

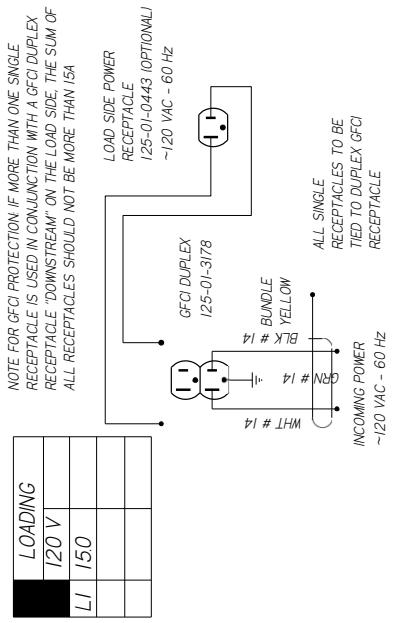

141 WARMERS  
MODEL #HWBH-43D  
240 VAC 5.0 AMPS  
1650 WATT@240  
IH69432550

LIMIT SWITCH  
I21 IH29361550

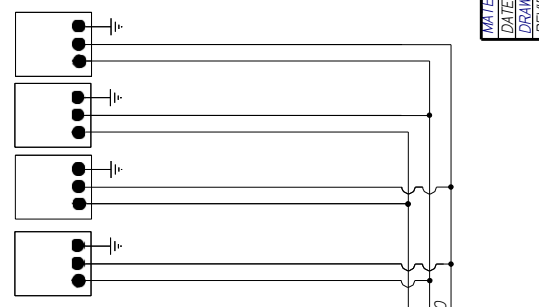

**HUSSMANN**  
DIAGRAM-Q-HS-5-SV  
-W

MATERIAL - NA  
DATE DRAWN - 6-22-15  
DRAWN BY - CRAIG BOOREY  
REVIEWED BY - CRAIG BOOREY  
ECON# - 989596  
REF -

SHEET 1 OF 3  
UNLESS OTHERWISE SPECIFIED DIMENSIONS ARE IN INCHES  
TOLERANCES ARE:  
THIRD ANGLE  
DECIMALS .XX +0.3 .XXX  
±0.0 ANGLES ± 2°  
PROJECTION

NOTES:  
CASE MUST BE GROUNDED

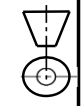

REV	ECN	DATE	REVISION DESCRIPTION	REV BY	CHKD BY	APPR BY
A	ECN-000-0017549	5-1-23	RELEASED TO PRODUCTION	CB	CB	CB
B	ECN-000-0017550	5-1-23	REVISED DIAGRAM NUMBER	CB	CB	CB

CIRCUIT #1	LOADING
208V	
L1	550
L2	550
L3	550
N	550
G	550

728-4W @ 208VAC

(2) F28T5-48"  
LIGHT CIRCUIT= 0.52A 56W

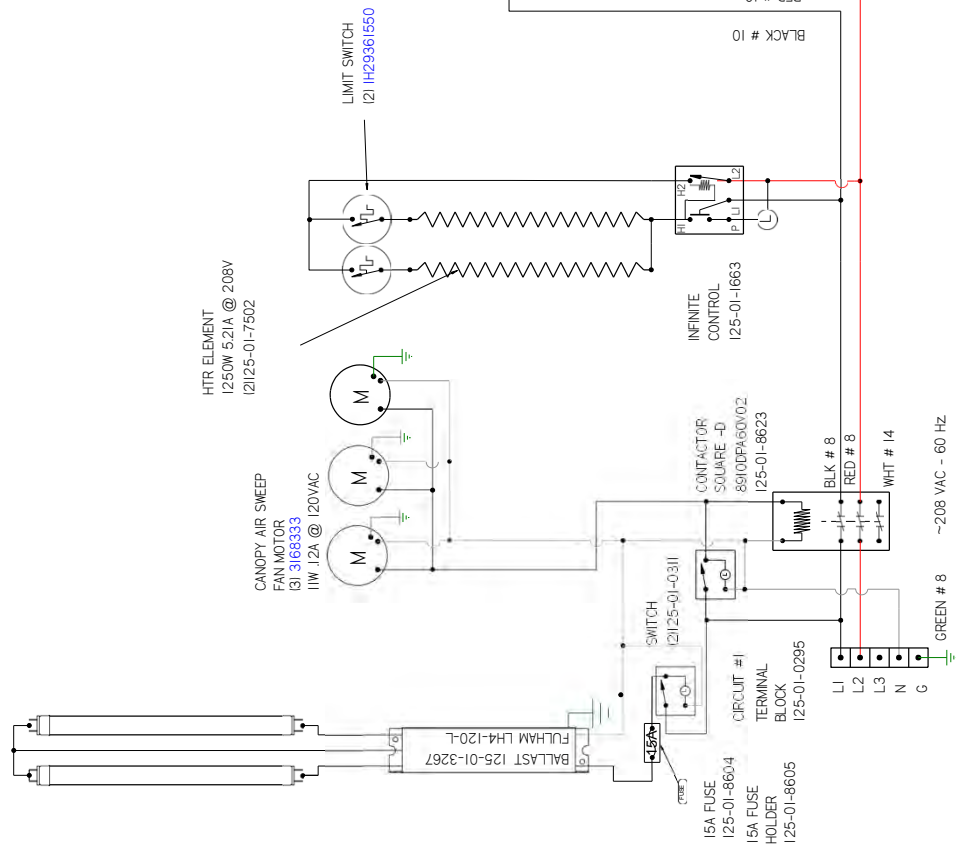
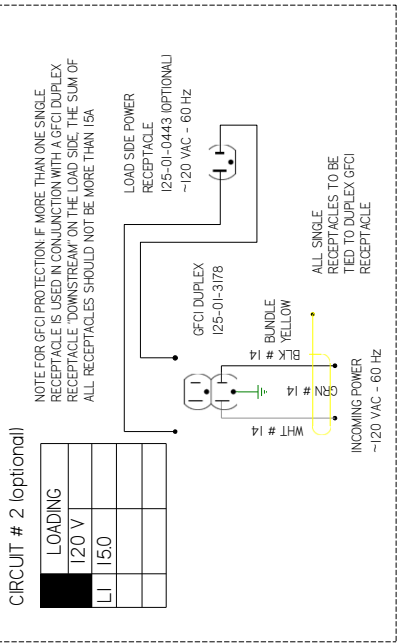

UL COLOR CODES / ABBREVIATIONS	
RED = RD	WHITE = WT
BLACK = BK	GREEN = GN
BLUE = BL	BROWN = BN
YELLOW = YL	ORANGE = OR
YL GRAY = YL GRAY	OR VIOLET = OR VIOLET
VT	

WIRE MARKER COLORS/ABBREVIATIONS	
BLACK = MBK	MAROON =
BLUE = MBL	MNR ORANGE =
BROWN = MBR	MO PINK = MPI
DARK BLUE =	PURPLE = MP
MDB GREEN = MG	RED = MR
LIGHT BLUE =	YELLOW = MYL

- NOTES:
1. PRINTED DOCUMENT REQUIRED SETTING. ALL COLORS BLACK & WHITE
  2. CASE & ANY REMOVABLE PANEL WITH ELECTRICAL PARTS MUST BE GROUNDED.
  3. WHEN PASSING WIRES THROUGH METAL HOLES A GROMMET MUST BE USED

**HUSSMANN**  
DIAGRAM-Q-HC-5-SV  
-W  
W6600919  
SHEET 1 OF 1

FACTORY 14GA WIRE
FACTORY LOGGA WIRE
FIELD WIRE
DO NOT SCALE DRAWING

CIRCUIT #1

LOADING	208V	240V
L1	100%	100%
L2	100%	100%
L3	100%	100%

3224W @ 208VAC  
4296W @ 240VAC

F281T5-48"  
I2125-03-1131

LIGHT CIRCUIT= 052A 56W

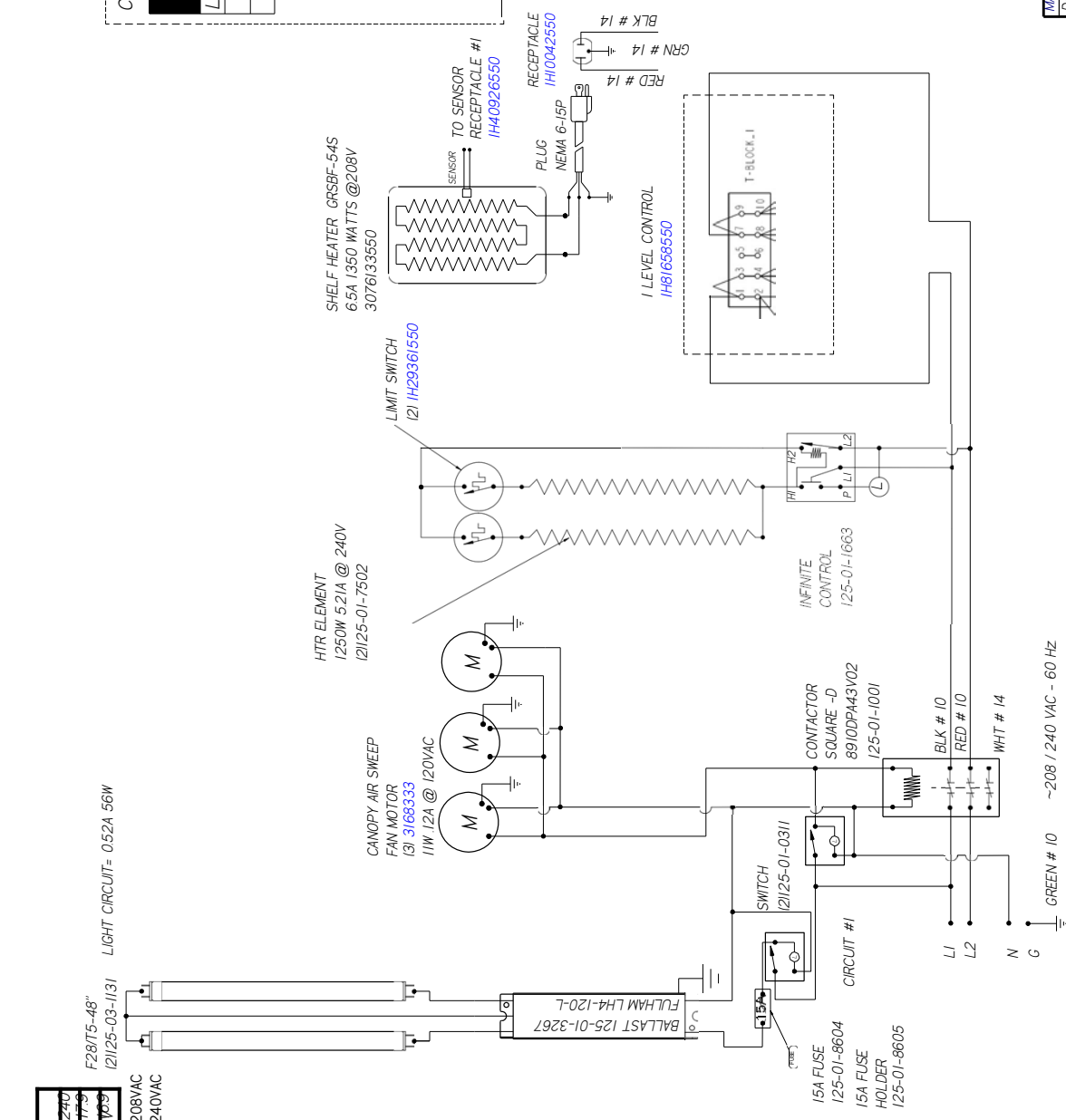
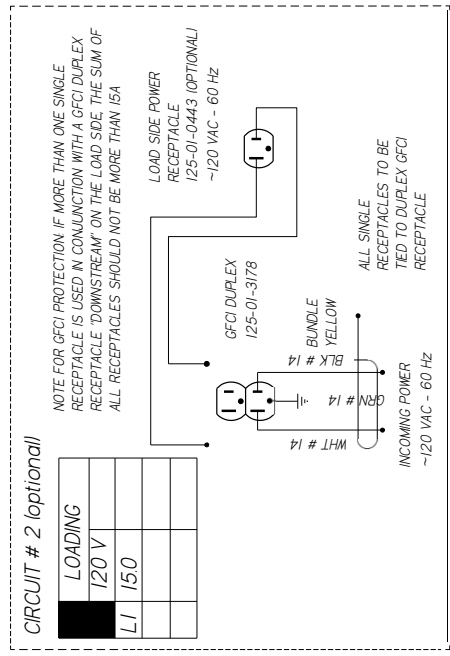

NOTES:  
CASE MUST BE GROUNDED  
WHEN PASSING WIRES THROUGH METAL HOLES A GROMMET MUST BE USED

**HUSSMAN**  
DIAGRAM-Q-HC-5-SS

MATERIAL - NA  
DATE DRAWN - 10-2-18  
DRAWN BY - CRAIG BOOREY  
REVIEWED BY - CRAIG BOOREY  
APPROVED BY - CRAIG BOOREY

REF -  
SHEET 1 OF 1  
UNLESS OTHERWISE SPECIFIED DIMENSIONS ARE IN INCHES  
TOLERANCES ARE:  
THIRD ANGLE PROJECTION

DECIMALS XX +0.3, XXX ±0.0  
ANGLES ± 2°

W6600458 | B



REVISION HISTORY			
REV	ECN	DATE	REVISION DESCRIPTION
A	ECN-000-0014472	7-30-21	RELEASED TO PRODUCTION
A	ECN-000-0017537	2-2-23	CHANGED TOP FAN

REV	ECN	DATE	REVISION DESCRIPTION
			REV BY (CHKD BY) APPR BY
			AL CB CB
			CB CB CB

CIRCUIT #1	LOADING
	208V
	L1 200W
	L2 278
	L3 174
	8257W @ 208VAC

41 F28/15-48"  
LIGHT CIRCUIT= 1.04A 112W

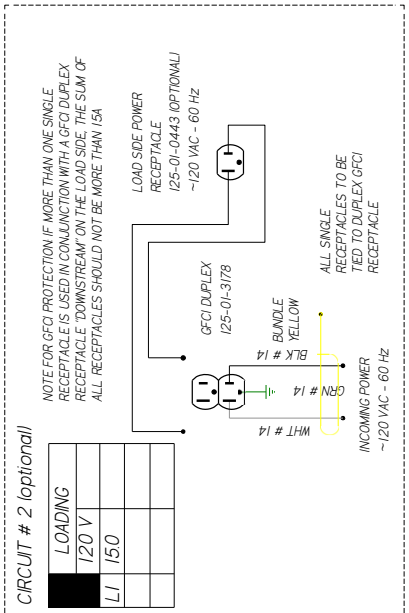
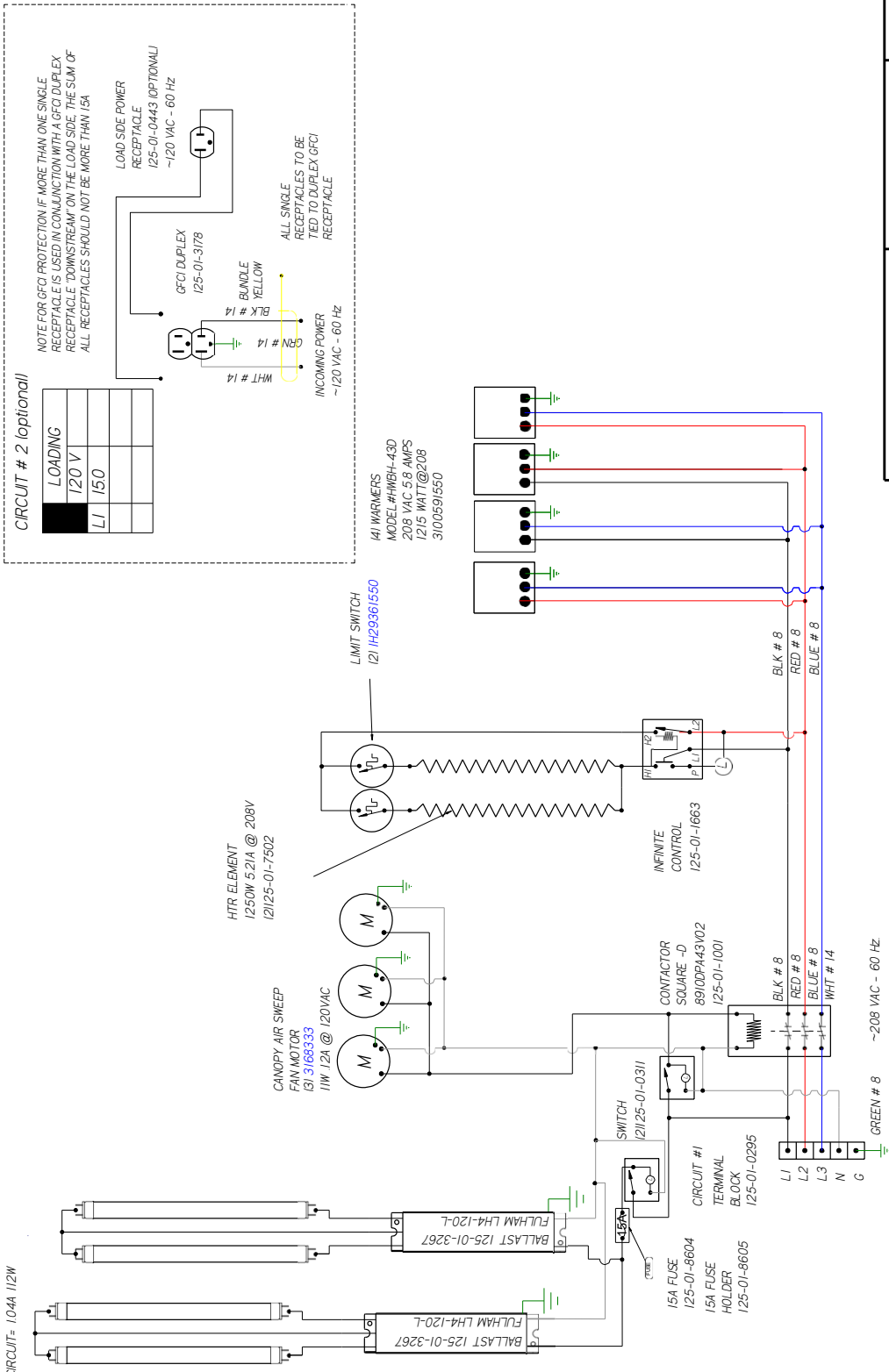

UL COLOR CODES / ABBREVIATIONS	
RED = RD	WHITE = WT
BLACK = BK	GREEN = GN
BLUE = BL	BROWN = BN
YELLOW = YL	ORANGE = OR
GRAY = GR	OR VIOLET = VT

WIRE MARKER COLORS/ABBREVIATIONS	
BLACK = MBK	MAROON = MR
BLUE = MBL	MMR ORANGE = MO
BROWN = MBR	MG PINK = MP
DARK BLUE = MD	PURPLE = MP
DOB GREEN = MG	RED = MR
LIGHT BLUE = ML	YELLOW = MYL

- NOTES:
1. PRINTED DOCUMENT REQUIRED SETTING. ALL COLORS BLACK & WHITE
  2. CASE & ANY REMOVABLE PANEL WITH ELECTRICAL PARTS MUST BE GROUNDED.
  3. WHEN PASSING WIRES THROUGH METAL HOLES A GROMMET MUST BE USED

**HUSSMANN**  
DIAGRAM-Q-HC-5-  
HO T 3-PHASE

FACTORY 14GA WIRE  
-FACTORY 10GA WIRE  
-FIELD WIRE  
DO NOT SCALE DRAWING  
SHEET 1 OF 1

W6600815  
REV B





REVISION HISTORY			
REV	ECN	DATE	REVISION DESCRIPTION
A	ECN-COD-0016850	1-19-23	RELEASED TO PRODUCTION
			REV BY/CHKD BY
			APPR BY
			CB
			CB

CIRCUIT #1

LOADING	240V	207V	120V	120V
5500W @ 208VAC				
7330W @ 240VAC				

5500W @ 208VAC  
7330W @ 240VAC

FLAT SURFACE WARMERS

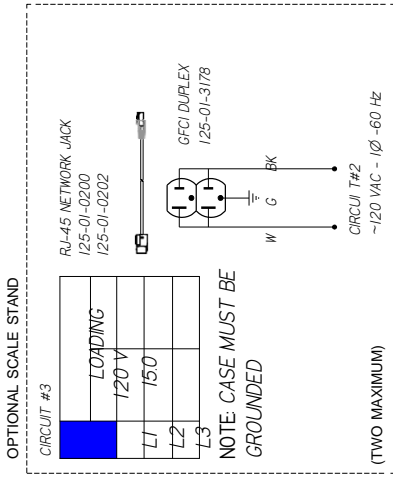
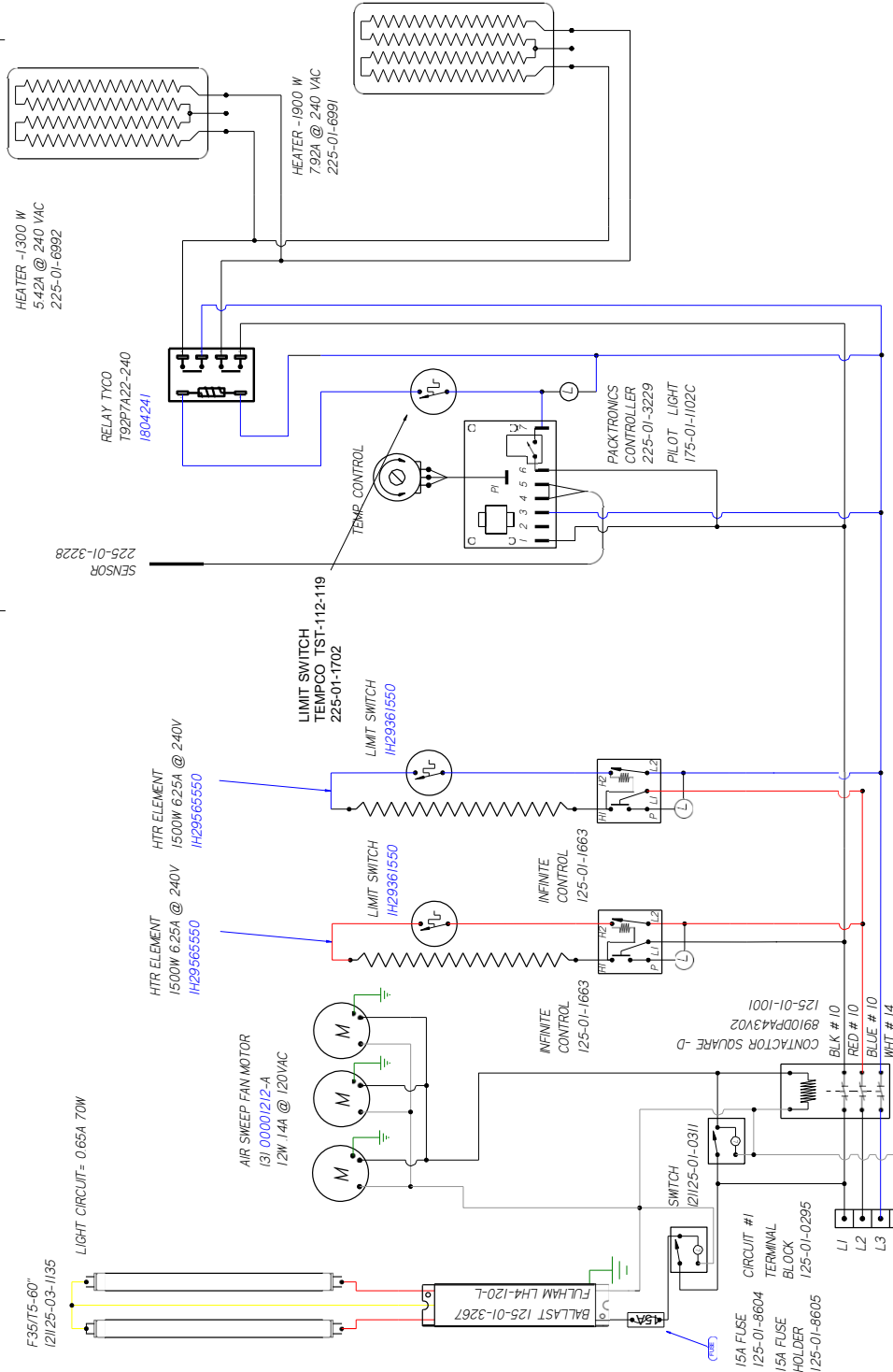

**HUSSMANN**  
DIAGRAM-Q-HS-6-SV

FACTORY 14GA WIRE  
FACTORY 10GA WIRE  
FIELD WIRE  
DO NOT SCALE DRAWING  
SHEET 1 OF 1

UL COLOR CODES / ABBREVIATIONS:  
RED = RD  
BLACK = BK  
BLUE = BL  
YELLOW = YL  
GRAY = GR  
WHITE = WT  
GREEN = GN  
BROWN = BN  
ORANGE = OR  
VIOLET = VT

WIRE MARKER COLORS/ABBREVIATIONS:  
MAROON = MBR  
MMR ORANGE = MMR  
MG PINK = MFP  
DARK BLUE = MDP  
MGB GREEN = MGG  
LIGHT BLUE = MLB  
PURPLE = MP  
RED = MR  
YELLOW = MYL

15A FUSE (125-01-8604)  
15A FUSE BLOCK (125-01-0295)  
HOLDER (125-01-8605)  
SWITCH (12125-01-0311)  
CIRCUIT #1 TERMINAL BLOCK (125-01-0295)  
CONTACTOR SQUARE-D (8910DPA43V02)  
BLK # 10  
RED # 10  
BLUE # 10  
WHT # 14  
GREEN # 8

~208 / 240 VAC - 50/60 HZ

- NOTES:
1. PRINTED DOCUMENT REQUIRED SETTING. ALL COLORS BLACK & WHITE
  2. CASE & ANY REMOVABLE PANEL WITH ELECTRICAL PARTS MUST BE GROUNDED.
  3. WHEN PASSING WIRES THROUGH METAL HOLES A GROMMET MUST BE USED

REV	EN	DATE	REVISION DESCRIPTION	REV BY	CHKD BY	APPR BY
1	EWV-735339	20/07/2013	RELEASED TO PRODUCTION	CB	CB	CB
2	EWV-CAR-0007285	20/07/2010	CHANGED TERMINAL BLOCK	CB	CB	CB
3	EWV-CAR-0020428	20/09/2009	ADDED 208V HOT WELL	CB	CB	CB
4	EWV-CAR-0020432	20/09/2009	ADDED 208V HOT WELL	CB	CB	CB
5	EWV-COB-0007337	20/03/2012	CHANGED TOP FAN	CB	CB	CB

CIRCUIT #1	LOADING
L1	150
L2	
L3	
N	
G	

LIGHT CIRCUIT= 0.65A 70W  
F35/830 T5-60"  
I2125-03-1134

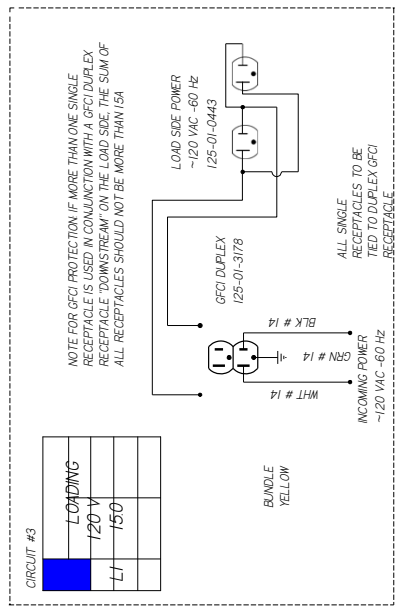

151 WARMERS  
MODEL #HWBH-43D 12" x 27"  
240 VAC 5.0 AMPS  
1200 WATT@240  
IH69432550 OR  
3100594550 208V  
3092096550

AIR SWEEP FAN MOTOR  
I31 3166333  
11W 12A @ 120VAC

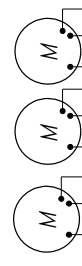

BALLAST 125-01-3267  
FULHAM LH4-120-L

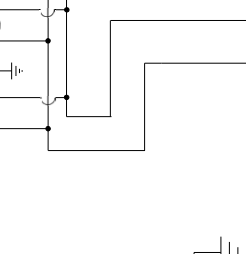

1500W 6.25A @ 240V  
I21 IH29565550

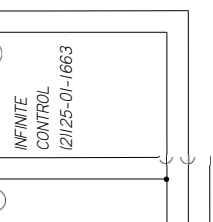
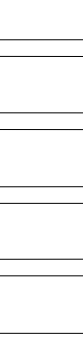

CONTACTOR SQUARE -D  
8910DP443V02 125-01-1001

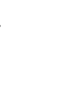

-208 / 240 VAC - 60 Hz  
GREEN # 8

**HUSSMANN**  
Q-HC-6-SV-W

MATERIAL - NA  
DATE DRAWN - 7/3/13  
DRAWN BY - CRAIG BOOREY  
REVIEWED BY - CRAIG BOOREY  
APPROVED BY - CRAIG BOOREY  
UNLESS OTHERWISE SPECIFIED DIMENSIONS ARE IN INCHES. TOLERANCES ARE:  
DECIMALS .XX +0.3 .XXX  
ANGLES ± 2°  
PROJECTION

ECN# - 735331 REF - NEW  
DIAGRAM SHEET LOE I

W6600084 | E

NOTES:  
CASE MUST BE GROUNDED



CIRCUIT #1

LDING	
208V	
L1	
L2	
L	

2  
8834W @ 208VAC

LIGHT CIRCUIT = 0.65A 70W

F351830 T5-60"  
12125-03-1134

CIRCUIT #2	LOADING
	120V
	L1
	150

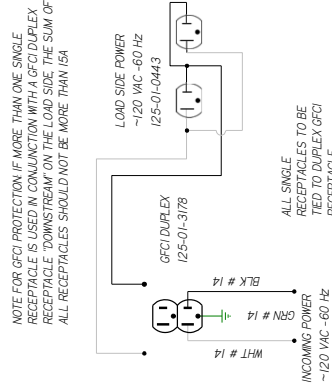

AIR SWEEP  
FAN MOTOR  
(3) 3168333  
11W 12A @ 120VAC

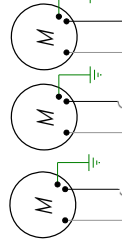

HTR ELEMENT  
1500W 6.25A @ 240V  
121 IH29565550



LIMIT SWITCH  
121 IH293616550



CIRCUIT #1

SWITCH  
12125-01-0311

15A FUSE  
125-01-8604  
15A FUSE  
HOLDER  
125-01-8605

CONTACTOR SQUARE -D  
89100PA43V02 125-01-8523

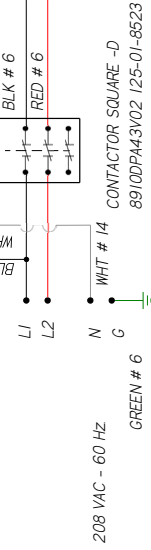

NOTES:

1. PRINTED DOCUMENT REQUIRED SETTING: ALL COLORS BLACK & WHITE
2. CASE MUST BE GROUNDED
3. WHEN PASSING WIRES THROUGH METAL HOLES A GROMMET MUST BE USED

REVISION HISTORY			
REV	ECN	DATE	REVISION DESCRIPTION
C	ECN-000-0011845	10-13-20	ADDED WIRE GAUGES
D	ECN-000-0017537	2-2-23	CHANGED TOP FAN

REVISION HISTORY			
REV	ECN	DATE	REVISION DESCRIPTION
			REV BY / CHKD BY / APPR BY
			CB / CB / CB
			CB / CB / CB

**HUSSMANN**  
DIAGRAM-Q-HV-6

FACTORY 14GA WIRE  
\_FACTORY 10GA WIRE  
\_FIELD WIRE  
\_DO NOT SCALE DRAWING  
SHEET 1 OF 1

UL COLOR CODES / ABBREVIATIONS  
 RED = RD  
 BLACK = BK  
 BLUE = BL  
 YELLOW = YL  
 GRAY = GR  
 WHITE = WT  
 GREEN = GN  
 BROWN = BN  
 ORANGE = OR  
 VIOLET = VT

W6600536  
SHEET 1 OF 1

REVISION HISTORY				
REV	EN	DATE	REVISION DESCRIPTION	REV BY / APPR BY
A	ECN-CAP-001844	2018/01/25	RELEASED TO PRODUCTION	CB / CB
B	ECN-COD-0017357	2023/02/02	CHANGED TOP FAN	CB / CB

CIRCUIT #1	LOADING
240V	
L1	150
L2	150
L3	0

2  
9288W @ 240VAC

LIGHT CIRCUIT= 0.65A 70W  
F351830 T5-60"  
12125-03-1134

CIRCUIT #3

LOADING
120V
L1
L2
L3

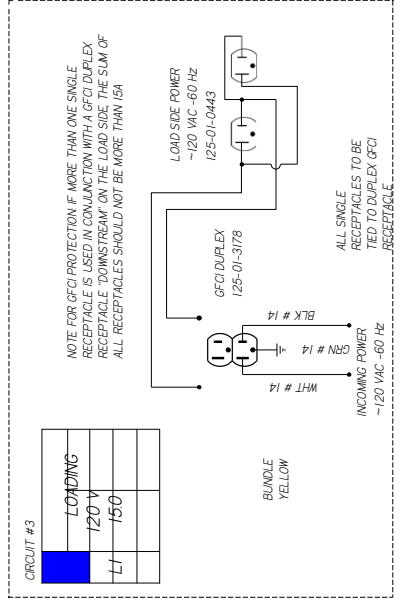

AIR SWEEP FAN MOTOR  
131 3168333  
11W .12A @ 120VAC

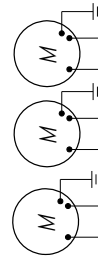

HTR ELEMENT  
1500W 6.25A @ 240V  
121 H295665550

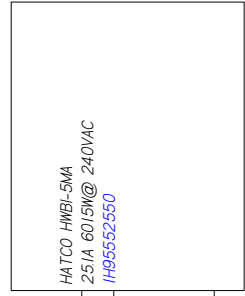

LIMIT SWITCH  
121 H29361550

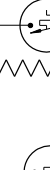

INFINITE CONTROL  
12125-01-1663

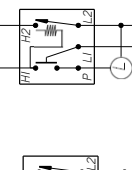

15A FUSE  
125-01-8604

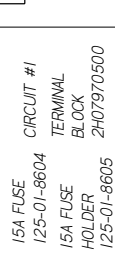

CIRCUIT #1  
TERMINAL BLOCK 2H07970500

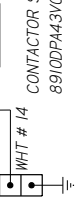

240 VAC - 60 Hz  
GREEN # 6

CONTACTOR SQUARE -D  
8910DPA43V02 125-01-8523

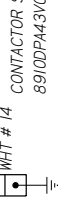

NOTES:  
CASE MUST BE GROUNDED  
WHEN PASSING WIRES THROUGH METAL HOLES A GROMMET MUST BE USED

**HUSSMAN**  
DIAGRAM-Q-HV-6

MATERIAL - NA  
DATE DRAWN -10-25-18  
DRAWN BY - CRAIG BOOREY  
REVIEWED BY - CRAIG BOOREY  
APPROVED BY - CRAIG BOOREY  
SHEET NO. 1  
UNLESS OTHERWISE SPECIFIED DIMENSIONS ARE IN INCHES  
TOLERANCES ARE:  
DECIMALS .XX +0.3 .XXX  
ANGLES ± 2°  
PROJECTION

W6600469 | B

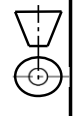

REV	ECN	DATE	REVISION DESCRIPTION	REV BY	CHKD BY	APPR BY
A	ECN-000-0011843	10-2-20	RELEASED TO PRODUCTION	CB	CB	CB
B	ECN-000-0017537	2-2-23	CHANGED TOP FAN	CB	CB	CB

CIRCUIT #	LOADING
4	120V
3	150V
2	
1	

4#26W @ 208VAC  
3

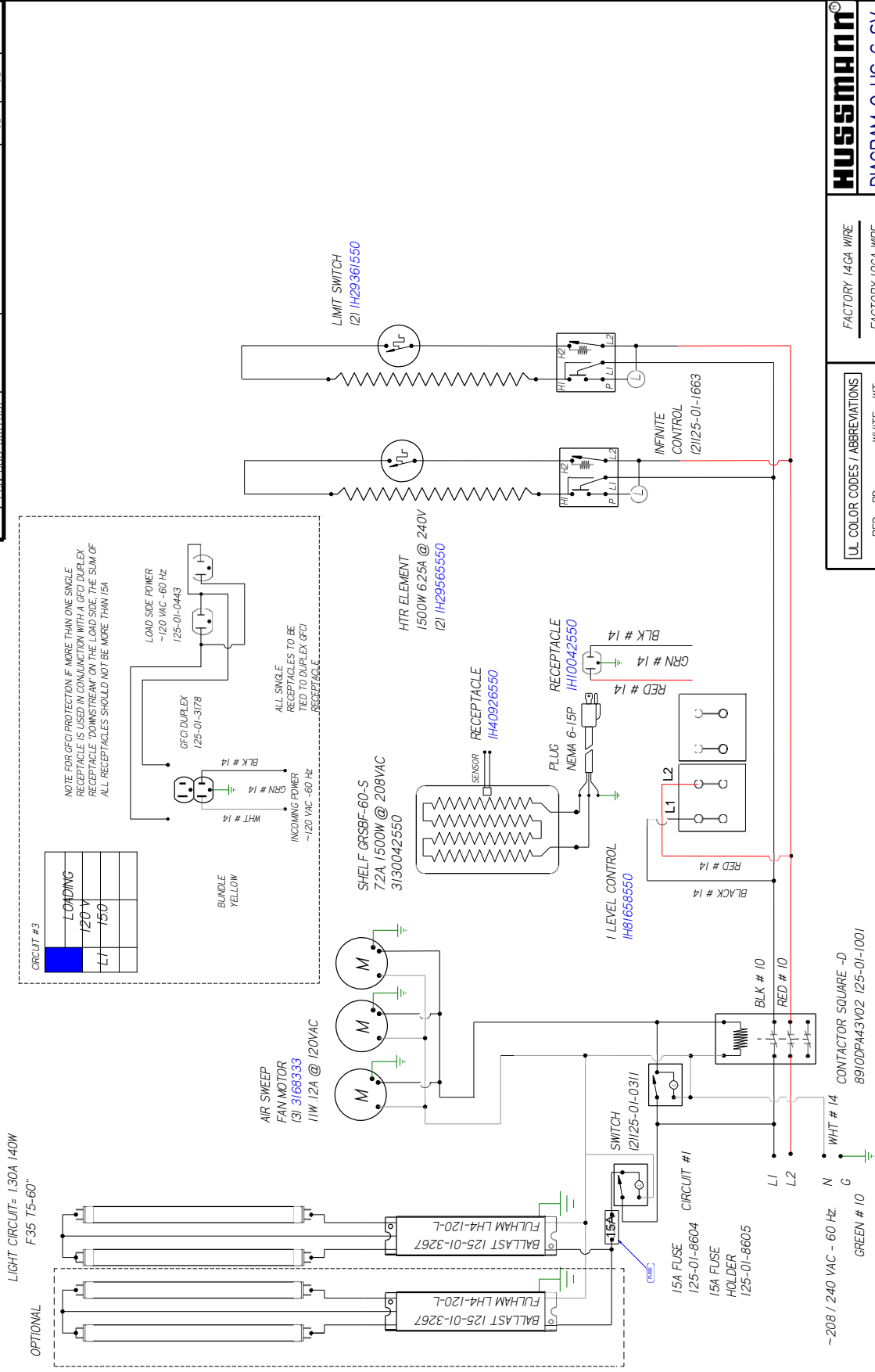

**UL COLOR CODES / ABBREVIATIONS**

- WHITE = WT
- GREEN = GN
- BROWN = BN
- ORANGE = OR
- OR VIOLET = VT
- GRAY = GR
- RED = RD
- BLACK = BK
- BLUE = BL
- YELLOW = YL

**FACTORY 14GA WIRE**

- FACTORY 10GA WIRE
- FIELD WIRE

**DO NOT SCALE DRAWING**

**SHEET 1 OF 1**

**HUSSMANN**

**DIAGRAM-Q-HC-6-SV**

**-W**

**W6600723**

**NOTES:**

- PRINTED DOCUMENT REQUIRED SETTING. ALL COLORS BLACK & WHITE
- CASE & ANY REMOVABLE PANEL WITH ELECTRICAL PARTS MUST BE GROUNDED.
- WHEN PASSING WIRES THROUGH METAL HOLES A GROMMET MUST BE USED

REVISION HISTORY			
REV	ECN	DATE	DESCRIPTION
D	ECN-000-0011330	6-23-20	OPTIONAL 2ND ROW LIGHTS
E	ECN-000-0017537	2-2-23	CHANGED TOP FANS

REV	BY	CHKD	BY	APPR	BY
					CB
					CB
					CB

UL COLOR CODES / ABBREVIATIONS
WHITE = WT
GREEN = GN
BROWN = BN
ORANGE = OR
OR VIOLET = VT
GY
RED = RD
BLACK = BK
BLUE = BL
YELLOW = YL
YL GRAY =

FACTORY 14GA WIRE
FACTORY 10GA WIRE
FIELD WIRE

DO NOT SCALE DRAWING
SHEET 1 OF 1

**HUSSMANN**  
**DIAGRAM-Q-HC-6-SV**  
**-W**

W600574  
 1000

REVISION HISTORY

REVISION HISTORY

REVISION HISTORY

REVISION HISTORY

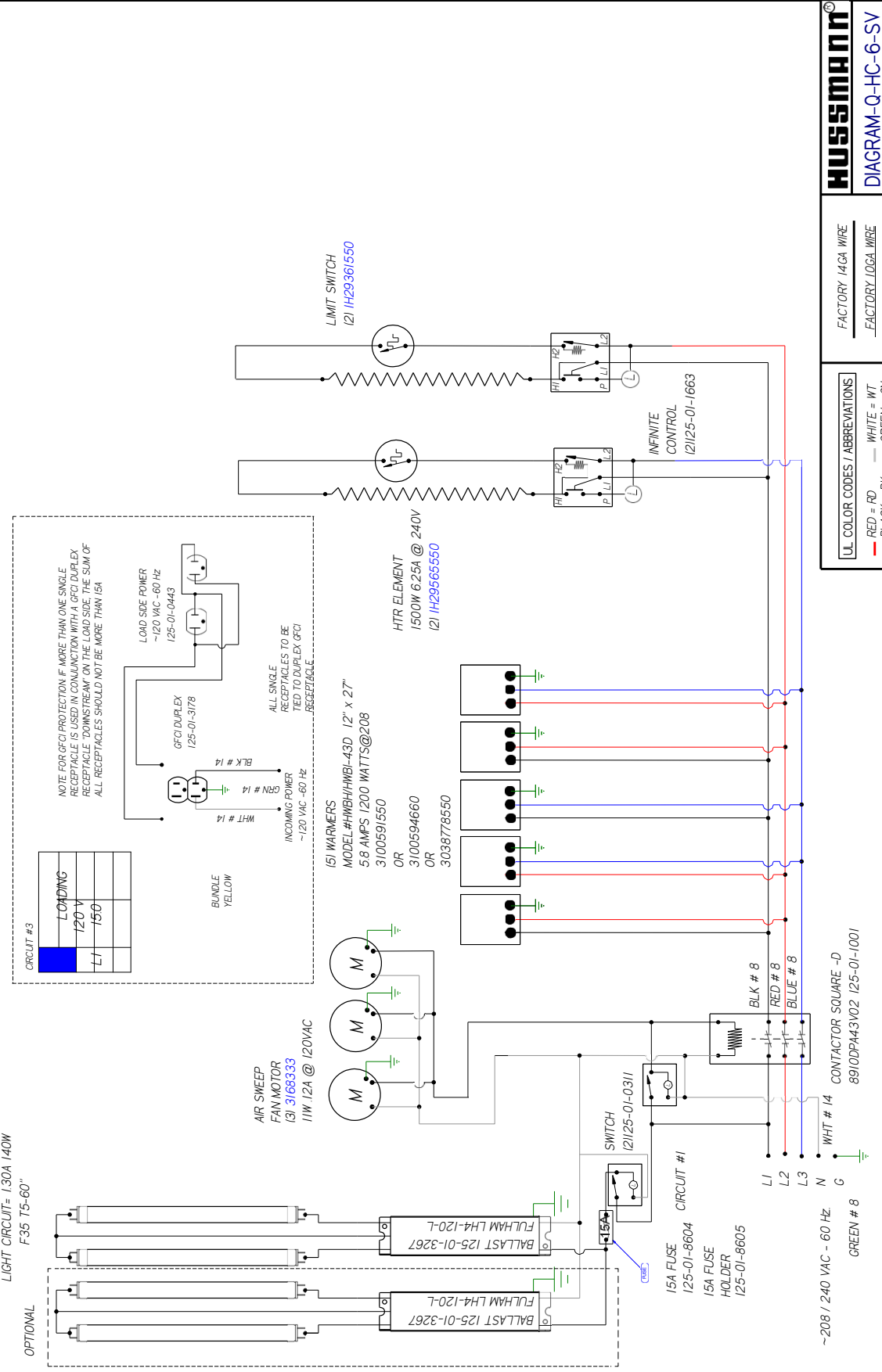

NOTE FOR GFCI PROTECTION IF MORE THAN ONE SINGLE RECEPTACLE IS USED IN CONJUNCTION WITH A GFCI DUPLEX RECEPTACLE "DOWNSTREAM" ON THE LOAD SIDE, THE SUM OF ALL RECEPTACLES SHOULD NOT BE MORE THAN 15A

LOAD SIDE POWER  
 ~120 VAC - 60 HZ  
 125-01-0443

ALL SINGLE RECEPTACLES TO BE TIED TO DUPLEX GFCI RECEPTACLE

GFCI DUPLEX  
 125-01-3178

INCOMING POWER  
 ~120 VAC - 60 HZ  
 BLK # 14  
 GRN # 14  
 WHT # 14

BUNDLE YELLOW

CIRCUIT #3

LOADING  
 120V  
 L1 150

15A WARMERS  
 MODEL #HWH/HMBI-43D 12" x 27"  
 5.8 AMPS 1200 WATTS@208  
 3100591550  
 OR  
 3100594660  
 OR  
 3038778550

HTR ELEMENT  
 1500W 625A @ 240V  
 121 IH29565550

LIMIT SWITCH  
 121 IH29361550

INFINITE CONTROL  
 12125-01-1663

AIR SWEEP FAN MOTOR  
 (3) 3168533  
 11W 12A @ 120VAC

15A FUSE CIRCUIT #1  
 125-01-8604

15A FUSE HOLDER  
 125-01-8605

SWITCH  
 12125-01-0311

CONTACTOR SQUARE -D  
 89100PA43V02 125-01-1001

~208 / 240 VAC - 60 Hz  
 GREEN # 8

WHT # 14  
 N  
 G

BLK # 8  
 RED # 8  
 BLUE # 8

NOTES:  
 1. PRINTED DOCUMENT REQUIRED SETTING. ALL COLORS BLACK & WHITE  
 2. CASE & ANY REMOVABLE PANEL WITH ELECTRICAL PARTS MUST BE GROUNDED.  
 3. WHEN PASSING WIRES THROUGH METAL HOLES A GROMMET MUST BE USED

CIRCUIT #1

LOADING
120V
L1 150
L2
L3

19063W @ 208VAC  
 3

CIRCUIT #1

CIRCUIT #1

REVISION HISTORY			
REV	EN	DATE	DESCRIPTION
A	01/06/03	20/06/06	RELEASED TO PRODUCTION
B	ECM-CDD-001/8337	20/02/02	CHANGED TOP/FANS

CIRCUIT #1	LDING	208V	240V

3062W @ 208VAC  
4060W @ 240VAC

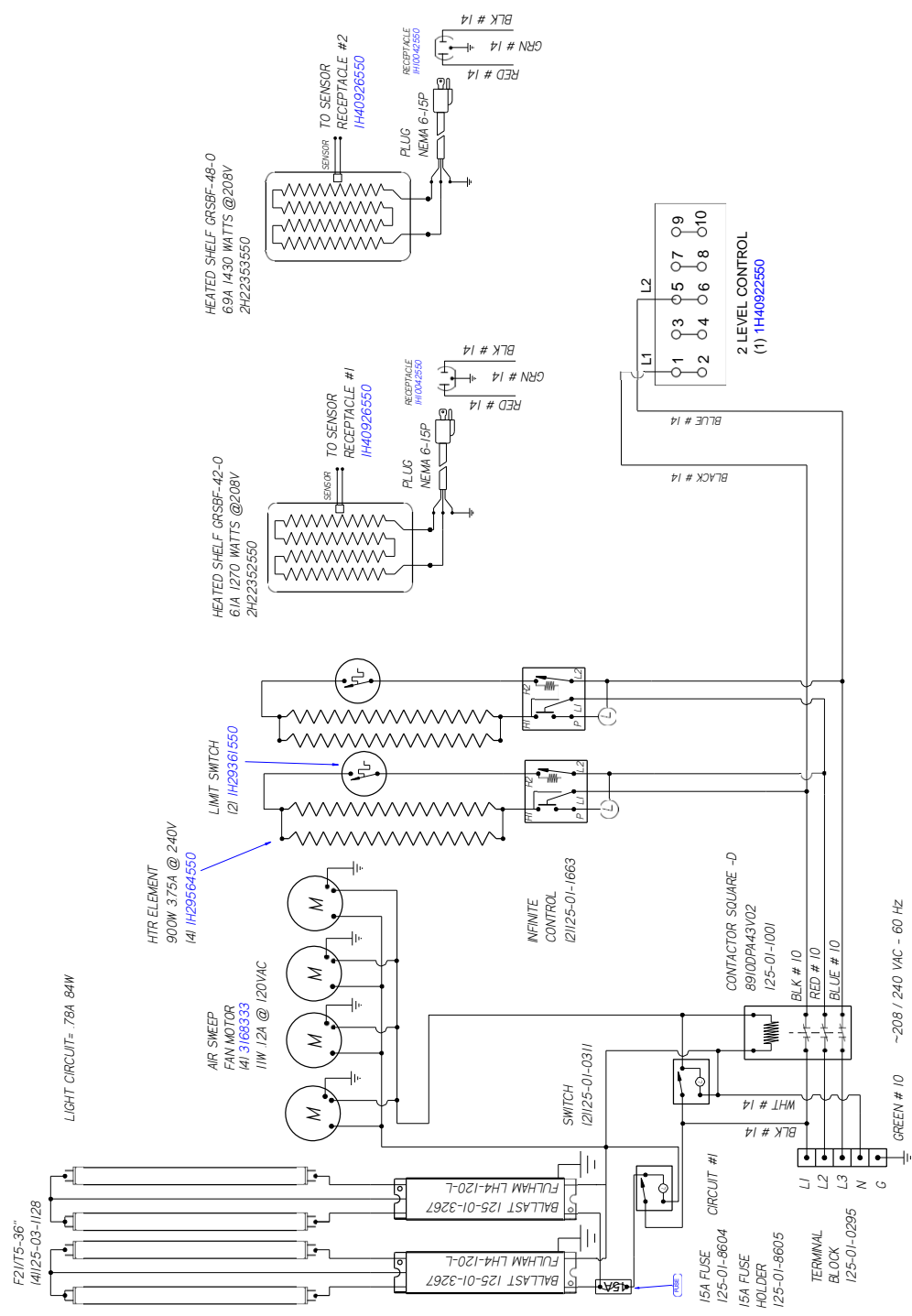

<b>MATERIAL - NA</b>	
DATE DRAWN - 1-6-16	ECNF - 1018503
DRAWN BY - CRAIG ROOREY	REF -
REVIEWED BY - CRAIG ROOREY	SHEET NO. -
UNLESS OTHERWISE SPECIFIED DIMENSIONS ARE IN INCHES	
TOLERANCES ARE:	
THIRD	ANG
E	PROJECTION
±0.0	ANGLES ± 2°

**HUSSMANN**  
DIAGRAM-Q-HC-8-SV  
-W

W6600182 | B

NOTES:  
CASE MUST BE GROUNDED

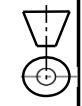

CIRCUIT #1

LOADING	208 V	240 V
L1	15.8	18.0
L2	16.9	19.6
L3	10.4	12.1

**5176W @ 208VAC**  
**6886W @ 240VAC**

GRIDDLE HEATERS  
 (2) 553W 2.30A @ ~240 VAC  
 225-01-6776

GRIDDLE HEATERS  
 (2) 553W 2.30A @ ~240 VAC  
 225-01-6776

SENSOR  
 225-01-3228

SENSOR  
 225-01-3228

LIMIT SWITCH  
 TEMPCO TST-112-119

LIMIT SWITCH  
 TEMPCO TST-112-119

LIGHT CIRCUIT= .78A 84W

HTR ELEMENT  
 900W / 3.75A @ 240V  
 (4) 1H29564550

AIR SWEEP  
 FAN MOTOR  
 (4) 3168333  
 11W .12A @ 120VAC

INFINITE  
 CONTROL  
 (2)125-01-1663

15A FUSE  
 125-01-8604

15A FUSE  
 HOLDER  
 125-01-8605

SWITCH  
 (2)125-01-0311

CONTACTOR SQUARE -D  
 8910DPA43V02  
 125-01-1001

TERMINAL  
 BLOCK  
 125-01-0295

GREEN # 10 ~208 / 240 VAC - 60 HZ.

F21/T5-36"  
 (4)125-03-1128

BALLAST 125-01-3267  
 FULHAM LH4-120-L

BALLAST 125-01-3267  
 FULHAM LH4-120-L

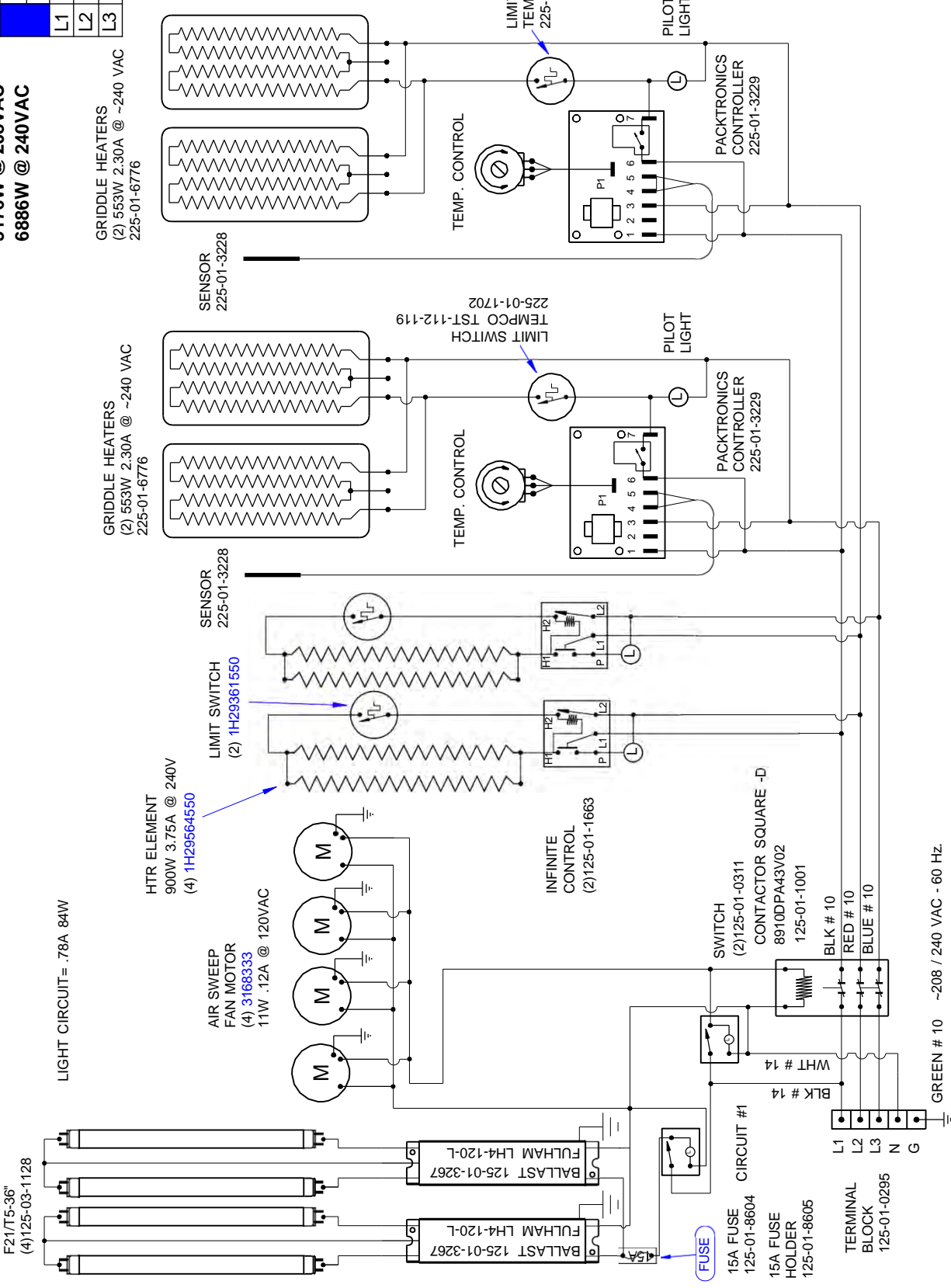

**HUSMANN**  
 Husmann Corporation, Inc.  
 13770 Ramona Avenue  
 Chino, CA 91710 Lic.#: 644406

REVISIONS:

#	DESCRIPTION	DATE	BY
B	Places fans in-line with main power switch	4/16/09	JR
C	Updated calroids and limit switches: revised load ratings	3/15/10	JR
D	ECN-COD-0017537 Changed Top Fans	2/2/23	CB

DRAWN BY: JESSE RIOS PROJECT TITLE: Q-H DRAWING #: W1750050  
 CHECKED BY: DATE: 9/15/08  
 PRODUCTION ORDER #: 603659 DRAWING TITLE: Q-HC-8SV-P  
 FILE LOCATION:

PAGE 1 OF 1

CIRCUIT #1

5176W @ 208VAC  
6886W @ 240VAC

LOADING	208 V	240 V
L1	15.8	18.0
L2	16.9	19.6
L3	10.4	12.1

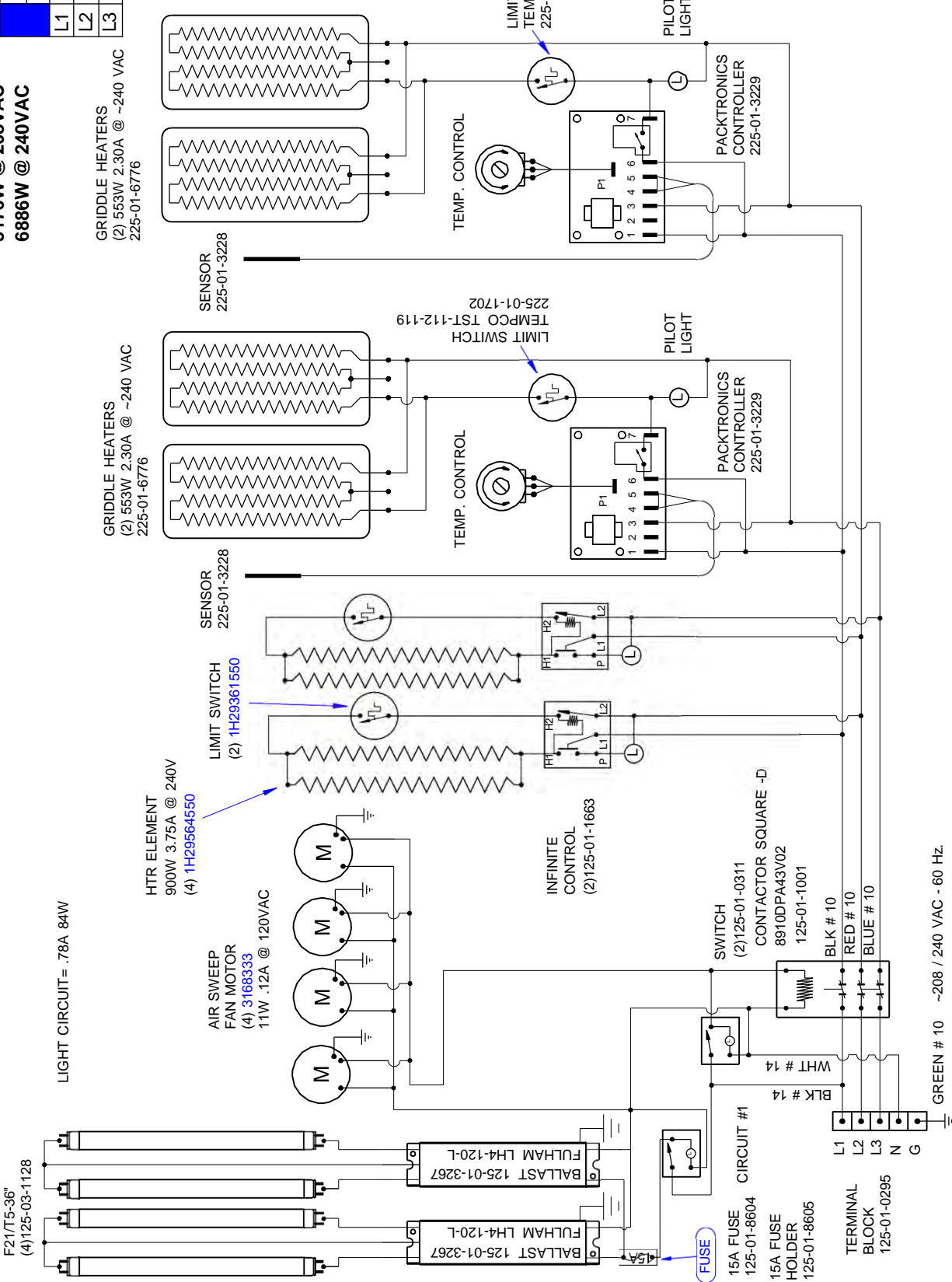

LIGHT CIRCUIT = .78A 84W

GRIDDLE HEATERS  
(2) 553W 2.30A @ ~240 VAC  
225-01-6776

GRIDDLE HEATERS  
(2) 553W 2.30A @ ~240 VAC  
225-01-6776

HTR ELEMENT  
900W 3.75A @ 240V  
(4) 1H29564550

AIR SWEEP  
FAN MOTOR  
(4) 3168333  
11W .12A @ 120VAC

SENSOR  
225-01-3228

SENSOR  
225-01-3228

TEMP. CONTROL

TEMP. CONTROL

INFINITE  
CONTROL  
(2)125-01-1663

15A FUSE  
125-01-8604  
15A FUSE  
HOLDER  
125-01-8605

SWITCH  
(2)125-01-0311  
CONTACTOR SQUARE -D  
8910DPA43V02  
125-01-1001

TERMINAL  
BLOCK  
125-01-0295

GREEN # 10 -208 / 240 VAC - 60 HZ.

**HUSSMANN**  
Hussmann Corporation, Inc.  
13770 Ramona Avenue  
Chino, CA 91710 Lic.#: 644406

REVISIONS:  
# DESCRIPTION: DATE: BY: DRAWN BY: PROJECT TITLE: Q-H  
B ECN-COD-0017538 CHANGED TOP FANS 2/3/23 CB PRODUCTION ORDER #: 622989 Q-HS-8-SS-G

DRAWING #: W6600021

PAGE 1 OF 1

LIGHT CIRCUIT= 0.78A 84W  
 F21/830 T5-36"  
 (4)125-03-1128

CIRCUIT #3	
LOADING	
120 V	
L1	15.0
L2	
L3	

NOTE FOR GFCI PROTECTION: IF MORE THAN ONE SINGLE RECEPTACLE IS USED IN CONJUNCTION WITH A GFCI DUPLEX RECEPTACLE "DOWNSTREAM" ON THE LOAD SIDE, THE SUM OF ALL RECEPTACLES SHOULD NOT BE MORE THAN 15A

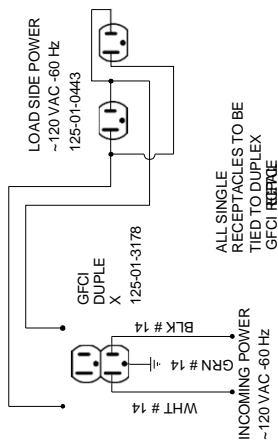

AIR SWEEP FAN MOTOR  
 (4) 31688333  
 11W .12A @ 120VAC

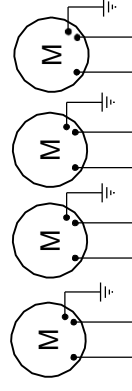

(6) WARMERS  
 MODEL#HWBH-43D 208 VAC  
 7.9 AMPS  
 240 VAC 6.9 AMPS  
 1650 WATT @240  
 1H69432550

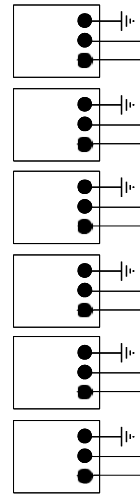

CIRCUIT #1	
LOADING	
208 V	240 V
L1	25.0
L2	23.9
L3	27.6

8742W @ 208VAC  
 11653W @ 240VAC

LIMIT SWITCH  
 (2) 1H29361550  
 HTR ELEMENT  
 900W 3.75A @ 240V  
 (4) 1H29564550

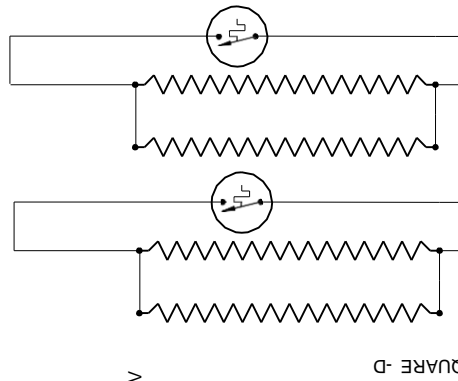

CONTRACTOR SQUARE - D  
 8910DPA43V02  
 125-01-1001

FUSE  
 15A FUSE  
 125-01-8604  
 15A FUSE  
 HOLDER  
 125-01-8605

SWITCH  
 (2)125-01-0311

CIRCUIT #1  
 TERMINAL  
 BLOCK  
 2H07970550

CONTRACTOR SQUARE - D  
 8910DPA43V02 125-01-1001  
 BLK # 8  
 RED # 8  
 BLUE # 8  
 WHT # 14

/ 240 VAC - 60 Hz.  
 GREEN # 8

CIRCUIT #2  
 TERMINAL  
 BLOCK  
 125-01-0295  
 L1  
 L2  
 L3  
 N  
 G  
 BLK # 10  
 RED # 10  
 BLUE # 10  
 WHT # 10  
 GREEN # 14

INFINITE  
 CONTROL  
 (2)125-01-1663

~208 / 240 VAC - 60 Hz.

**HUSSMANN**  
 Hussmann Corporation, Inc.  
 13770 Ramona Avenue  
 Chino, CA 91710 Lic.#: 644406  
 (909) 590-4910

REVISIONS:  
 # DESCRIPTION  
 B ECN-CAP-0007285 CHANGED TERMINAL BLOCK  
 C ECN-CAP-0010805 REVISED WELL PART NUMBER  
 D ECN-COD-0017538 CHANGED TOP FANS

DRAWN BY: CRAIG BOOREY PROJECT TITLE: QH  
 CHECKED BY: DATE: 3/16/12  
 BY: 4/10/17 CB PRODUCTION ORDER #: 565061  
 12/1/17 CB FILE LOCATION:  
 2/3/23 CB

DRAWING #: W6600023  
 Q-HC-SV-W 8' WITH INDIVIDUAL WELLS  
 PAGE 1 OF 1

REVISION HISTORY		REV	DATE	DESCRIPTION	BY	CHK BY	APP BY
1	REVISED TO PRODUCTION	01	20/01/05		CB	CB	CB
2	CHANGED TOP FANS	02	20/20/2013		CB	CB	CB

CIRCUIT #3	
LOADING	
L1	150
L2	200
L3	200

CIRCUIT #2	
LOADING	
L1	213
L2	200
L3	200

CIRCUIT #1	
LOADING	
L1	75
L2	150
L3	75

8494W @ 240VAC

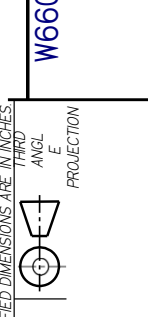
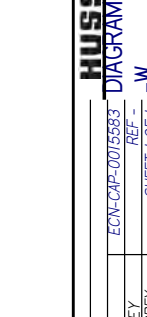
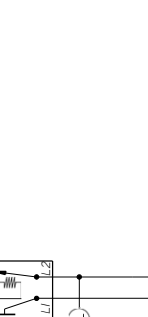
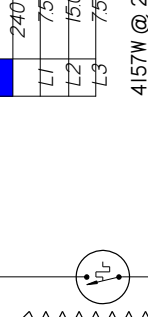
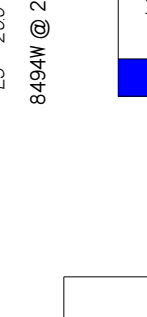
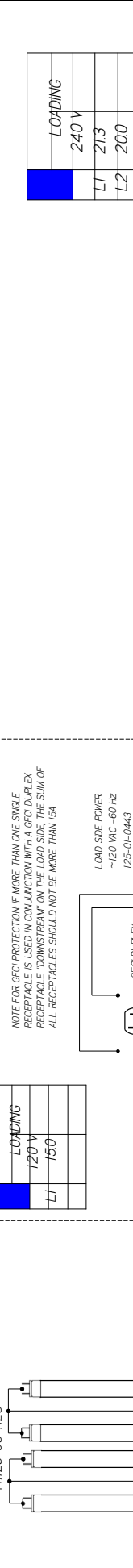

NOTE FOR GFCI PROTECTION IF MORE THAN ONE SINGLE RECEPTACLE IS USED IN CONJUNCTION WITH A GFCI DUPLEX RECEPTACLE 'DOWNSTREAM' ON THE LOAD SIDE, THE SUM OF ALL RECEPTACLES SHOULD NOT BE MORE THAN 15A

ALL SINGLE RECEPTACLES TO BE TIED TO DUPLEX GFCI RECEPTACLE.

(6) WARMERS  
MODEL #HMBH-43D  
240 VAC 5.0 AMPS  
1/200 WHIT@240  
1H94974550

15A FUSE  
125-01-8604  
15A FUSE  
HOLDER  
125-01-8605

12/125-01-0311  
SWITCH

125-01-0295  
TERMINAL  
BLOCK  
CIRCUIT #2

125-01-1663  
INFINITE  
CONTROL

8910DPA43V02  
CONTACTOR SQUARE -D

125-01-1001  
LIMIT SWITCH

900W 375A @ 240V  
HTR ELEMENT

125-01-3178  
GFCI DUPLEX

125-01-0443  
LOAD SIDE POWER

125-01-3267  
BALLAST

125-01-3267  
BALLAST

1/1W 12A @ 120VAC  
AIR SWEEP  
FAN MOTOR

125-01-8605  
15A FUSE  
HOLDER

125-01-8604  
15A FUSE

12/125-01-0311  
SWITCH

125-01-0295  
TERMINAL  
BLOCK

12/125-01-1663  
INFINITE  
CONTROL

8910DPA43V02  
CONTACTOR SQUARE -D

125-01-1001  
LIMIT SWITCH

900W 375A @ 240V  
HTR ELEMENT

125-01-3178  
GFCI DUPLEX

125-01-0443  
LOAD SIDE POWER

125-01-3267  
BALLAST

125-01-3267  
BALLAST

1/1W 12A @ 120VAC  
AIR SWEEP  
FAN MOTOR

125-01-8605  
15A FUSE  
HOLDER

125-01-8604  
15A FUSE

12/125-01-0311  
SWITCH

125-01-0295  
TERMINAL  
BLOCK

12/125-01-1663  
INFINITE  
CONTROL

8910DPA43V02  
CONTACTOR SQUARE -D

125-01-1001  
LIMIT SWITCH

900W 375A @ 240V  
HTR ELEMENT

125-01-3178  
GFCI DUPLEX

125-01-0443  
LOAD SIDE POWER

125-01-3267  
BALLAST

125-01-3267  
BALLAST

1/1W 12A @ 120VAC  
AIR SWEEP  
FAN MOTOR

125-01-8605  
15A FUSE  
HOLDER

125-01-8604  
15A FUSE

12/125-01-0311  
SWITCH

125-01-0295  
TERMINAL  
BLOCK

12/125-01-1663  
INFINITE  
CONTROL

8910DPA43V02  
CONTACTOR SQUARE -D

125-01-1001  
LIMIT SWITCH

900W 375A @ 240V  
HTR ELEMENT

125-01-3178  
GFCI DUPLEX

125-01-0443  
LOAD SIDE POWER

125-01-3267  
BALLAST

125-01-3267  
BALLAST

1/1W 12A @ 120VAC  
AIR SWEEP  
FAN MOTOR

125-01-8605  
15A FUSE  
HOLDER

125-01-8604  
15A FUSE

12/125-01-0311  
SWITCH

125-01-0295  
TERMINAL  
BLOCK

12/125-01-1663  
INFINITE  
CONTROL

8910DPA43V02  
CONTACTOR SQUARE -D

125-01-1001  
LIMIT SWITCH

900W 375A @ 240V  
HTR ELEMENT

125-01-3178  
GFCI DUPLEX

125-01-0443  
LOAD SIDE POWER

125-01-3267  
BALLAST

125-01-3267  
BALLAST

1/1W 12A @ 120VAC  
AIR SWEEP  
FAN MOTOR

125-01-8605  
15A FUSE  
HOLDER

125-01-8604  
15A FUSE

12/125-01-0311  
SWITCH

125-01-0295  
TERMINAL  
BLOCK

12/125-01-1663  
INFINITE  
CONTROL

8910DPA43V02  
CONTACTOR SQUARE -D

125-01-1001  
LIMIT SWITCH

900W 375A @ 240V  
HTR ELEMENT

125-01-3178  
GFCI DUPLEX

125-01-0443  
LOAD SIDE POWER

125-01-3267  
BALLAST

125-01-3267  
BALLAST

1/1W 12A @ 120VAC  
AIR SWEEP  
FAN MOTOR

125-01-8605  
15A FUSE  
HOLDER

125-01-8604  
15A FUSE

12/125-01-0311  
SWITCH

125-01-0295  
TERMINAL  
BLOCK

12/125-01-1663  
INFINITE  
CONTROL

8910DPA43V02  
CONTACTOR SQUARE -D

125-01-1001  
LIMIT SWITCH

900W 375A @ 240V  
HTR ELEMENT

125-01-3178  
GFCI DUPLEX

125-01-0443  
LOAD SIDE POWER

125-01-3267  
BALLAST

125-01-3267  
BALLAST

1/1W 12A @ 120VAC  
AIR SWEEP  
FAN MOTOR

125-01-8605  
15A FUSE  
HOLDER

125-01-8604  
15A FUSE

12/125-01-0311  
SWITCH

125-01-0295  
TERMINAL  
BLOCK

12/125-01-1663  
INFINITE  
CONTROL

8910DPA43V02  
CONTACTOR SQUARE -D

125-01-1001  
LIMIT SWITCH

900W 375A @ 240V  
HTR ELEMENT

125-01-3178  
GFCI DUPLEX

125-01-0443  
LOAD SIDE POWER

125-01-3267  
BALLAST

125-01-3267  
BALLAST

1/1W 12A @ 120VAC  
AIR SWEEP  
FAN MOTOR

125-01-8605  
15A FUSE  
HOLDER

125-01-8604  
15A FUSE

12/125-01-0311  
SWITCH

125-01-0295  
TERMINAL  
BLOCK

12/125-01-1663  
INFINITE  
CONTROL

8910DPA43V02  
CONTACTOR SQUARE -D

125-01-1001  
LIMIT SWITCH

900W 375A @ 240V  
HTR ELEMENT

125-01-3178  
GFCI DUPLEX

125-01-0443  
LOAD SIDE POWER

125-01-3267  
BALLAST

125-01-3267  
BALLAST

1/1W 12A @ 120VAC  
AIR SWEEP  
FAN MOTOR

125-01-8605  
15A FUSE  
HOLDER

125-01-8604  
15A FUSE

12/125-01-0311  
SWITCH

125-01-0295  
TERMINAL  
BLOCK

12/125-01-1663  
INFINITE  
CONTROL

8910DPA43V02  
CONTACTOR SQUARE -D

125-01-1001  
LIMIT SWITCH

900W 375A @ 240V  
HTR ELEMENT

125-01-3178  
GFCI DUPLEX

125-01-0443  
LOAD SIDE POWER

125-01-3267  
BALLAST

125-01-3267  
BALLAST

1/1W 12A @ 120VAC  
AIR SWEEP  
FAN MOTOR

125-01-8605  
15A FUSE  
HOLDER

125-01-8604  
15A FUSE

12/125-01-0311  
SWITCH

125-01-0295  
TERMINAL  
BLOCK

12/125-01-1663  
INFINITE  
CONTROL

8910DPA43V02  
CONTACTOR SQUARE -D

125-01-1001  
LIMIT SWITCH

900W 375A @ 240V  
HTR ELEMENT

125-01-3178  
GFCI DUPLEX

125-01-0443  
LOAD SIDE POWER

125-01-3267  
BALLAST

125-01-3267  
BALLAST

1/1W 12A @ 120VAC  
AIR SWEEP  
FAN MOTOR

125-01-8605  
15A FUSE  
HOLDER

125-01-8604  
15A FUSE

12/125-01-0311  
SWITCH

125-01-0295  
TERMINAL  
BLOCK

12/125-01-1663  
INFINITE  
CONTROL

8910DPA43V02  
CONTACTOR SQUARE -D

125-01-1001  
LIMIT SWITCH

900W 375A @ 240V  
HTR ELEMENT

125-01-3178  
GFCI DUPLEX

125-01-0443  
LOAD SIDE POWER

125-01-3267  
BALLAST

125-01-3267  
BALLAST

1/1W 12A @ 120VAC  
AIR SWEEP  
FAN MOTOR

125-01-8605  
15A FUSE  
HOLDER

125-01-8604  
15A FUSE

12/125-01-0311  
SWITCH

125-01-0295  
TERMINAL  
BLOCK

12/125-01-1663  
INFINITE  
CONTROL

8910DPA43V02  
CONTACTOR SQUARE -D

125-01-1001  
LIMIT SWITCH

900W 375A @ 240V  
HTR ELEMENT

125-01-3178  
GFCI DUPLEX

125-01-0443  
LOAD SIDE POWER

125-01-3267  
BALLAST

125-01-3267  
BALLAST

1/1W 12A @ 120VAC  
AIR SWEEP  
FAN MOTOR

125-01-8605  
15A FUSE  
HOLDER

LOADING	
208 V	
L1	245
L2	232
L3	232

8514W @ 208VAC

LOADING	
208 V	
L1	7.5
L2	15.0
L3	7.5

3602W @ 208VAC

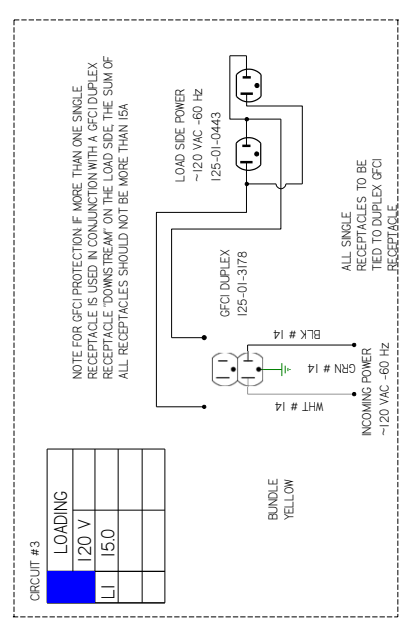

REVISION HISTORY						
REV	ECN	DATE	REVISION DESCRIPTION	REV BY	CHKD BY	APPR BY
C	ECN-COD-0017538	2-3-23	CHANGED TOP FANS	CB	CB	CB
D	ECN-COD-0017544	3-16-23	ADDED HOT WELL PART #	CB	CB	CB

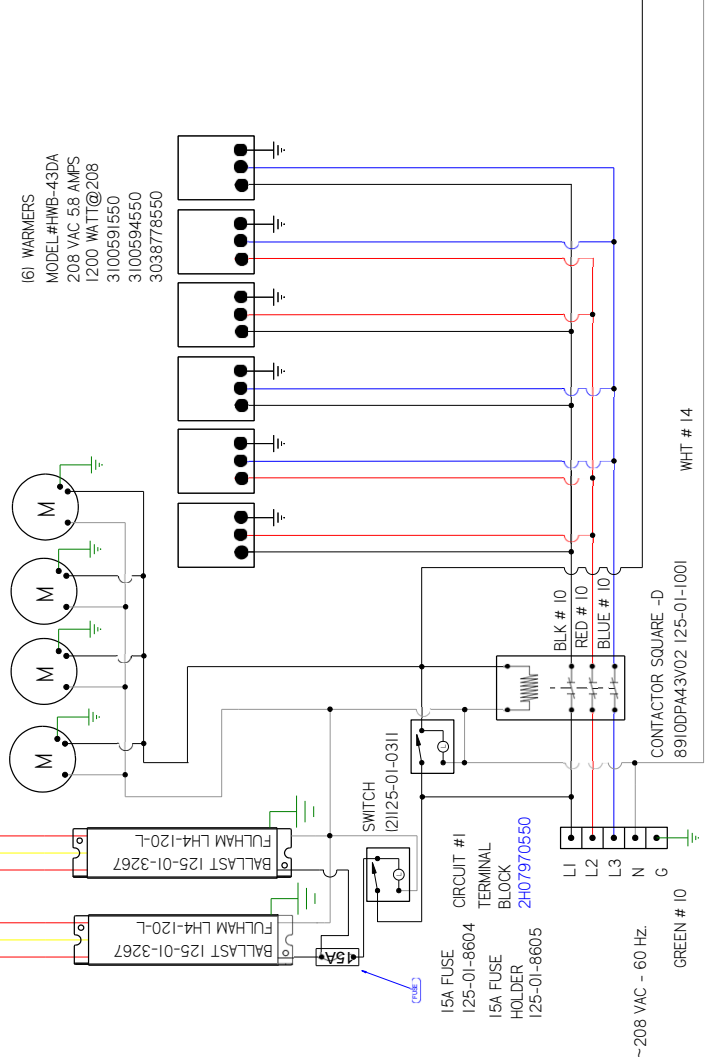
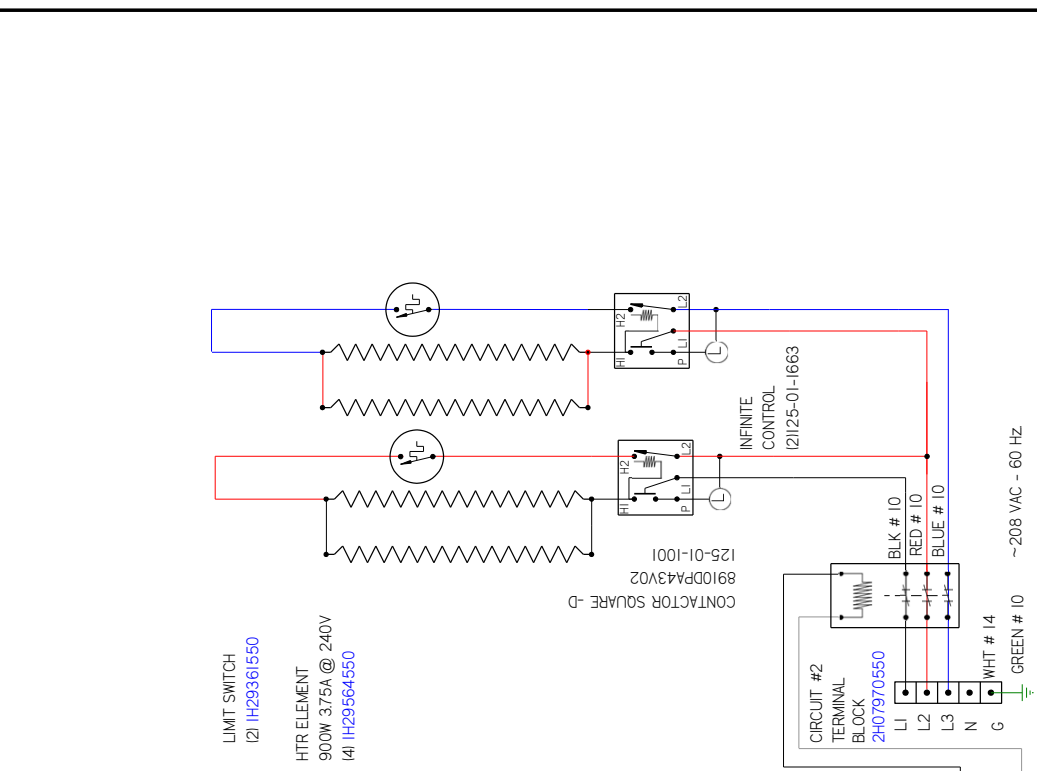

**HUSSMANN**

DIAGRAM-Q-HS-8

DO NOT SCALE DRAWING

SHEET 1 OF 1

FACTORY 14GA WIRE

FACTORY LOGA WIRE

FIELD WIRE

UL COLOR CODES / ABBREVIATIONS

RED = RD  
BLACK = BK  
BLUE = BL  
YELLOW = YL  
GRAY = GR

WHITE = WT  
GREEN = GN  
BROWN = BN  
ORANGE = OR  
VIOLET = VT

- NOTES:
1. PRINTED DOCUMENT REQUIRED SETTING: ALL COLORS BLACK & WHITE
  2. CASE & ANY REMOVABLE PANEL WITH ELECTRICAL PARTS MUST BE GROUNDED.
  3. WHEN PASSING WIRES THROUGH METAL HOLES A GROMMET MUST BE USED

REVISION HISTORY			
REV	ECN	DATE	REVISION DESCRIPTION
A	ECN-COD-0014494	8-13-21	RELEASED TO PRODUCTION
B	ECN-COD-0017538	2-3-23	CHANGED TOP FANS

REV	BY	CHKD	BY	APPR	BY
CB	CB	CB	CB	CB	CB
CB	CB	CB	CB	CB	CB

CIRCUIT #1	LOADING
200V	
150V	
120V	

7488W @ 208VAC

CIRCUIT #2	LOADING
200V	
150V	
120V	

3120W @ 208VAC

NOTE FOR GFCI PROTECTION IF MORE THAN ONE SINGLE RECEPTACLE IS USED IN CONJUNCTION WITH A GFCI DUPLEX RECEPTACLE "DOWNSTREAM" ON THE LOAD SIDE, THE SUM OF ALL RECEPTACLES SHOULD NOT BE MORE THAN 15A

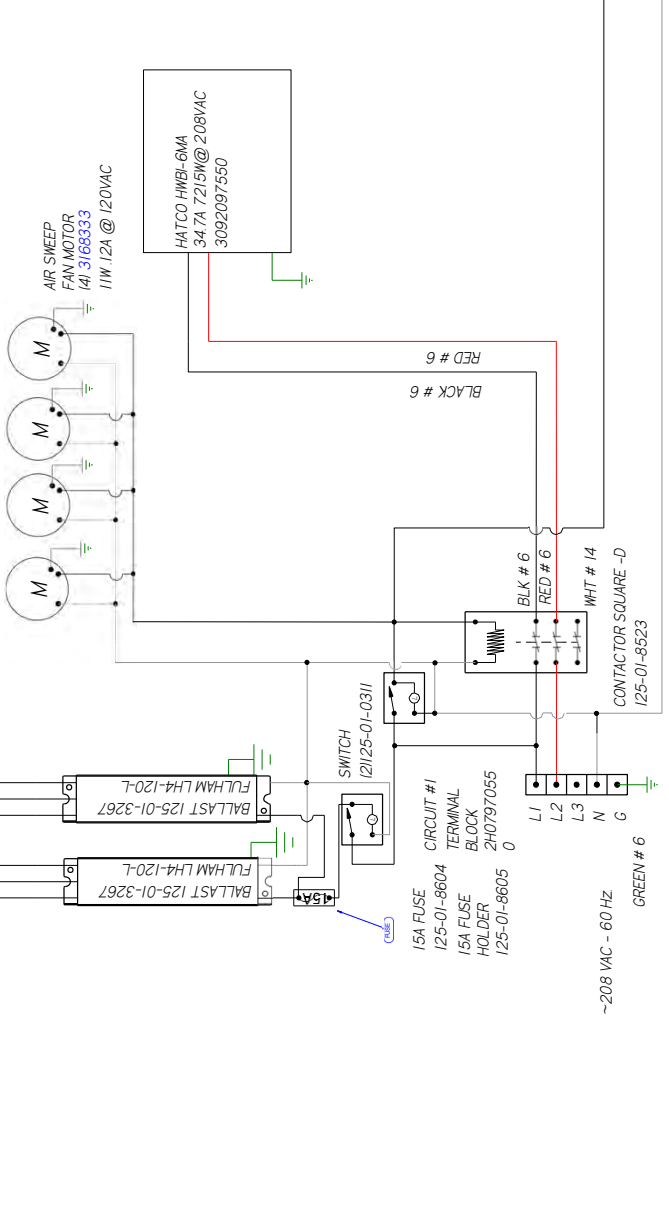
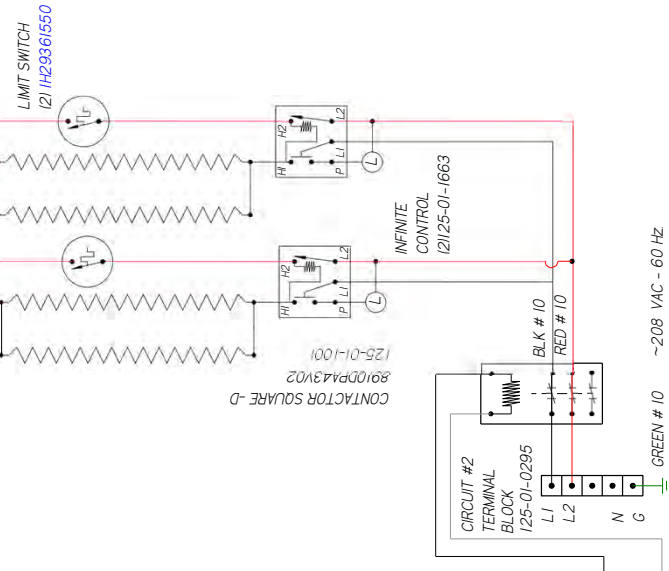
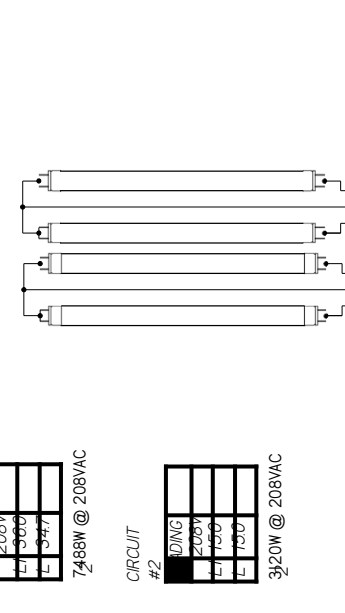
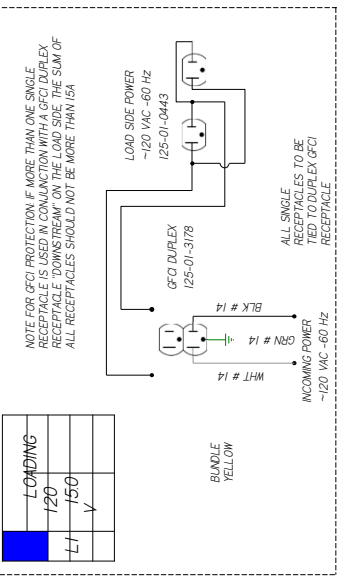

**HUSSMANN**  
DIAGRAM-Q-HS-8-SV  
-W

FACTORY 14GA WIRE  
-FACTORY 10GA WIRE  
-FIELD WIRE  
-DO NOT SCALE DRAWING  
SHEET 1 OF 1

UL COLOR CODES / ABBREVIATIONS	WIRE MARKER COLORS/ABBREVIATIONS
RED = RD	MAROON =
BLACK = BK	MMR ORANGE =
BLUE = BL	MG PINK = MFI
YELLOW = YL	PURPLE = MP
OR VIOLET =	RED = MR
VT	YELL-GREEN = MG
	LIGHT-BLUE =
	YELLOW = MYL

- NOTES:
1. PRINTED DOCUMENT REQUIRED SETTING. ALL COLORS BLACK & WHITE
  2. CASE & ANY REMOVABLE PANEL WITH ELECTRICAL PARTS MUST BE GROUNDED.
  3. WHEN PASSING WIRES THROUGH METAL HOLES A GROMMET MUST BE USED

REVISION HISTORY			
REV	EN	DATE	DESCRIPTION
A	ECN-CAP-0074936	2018/01/02	RELEASED TO PRODUCTION
B	ECN-CAP-0074942	2018/01/02	RELABEL WIRE COLOR
C	ECN-CAP-0076358	2023/02/03	CHANGED TOP FANS

REV	EN	DATE	DESCRIPTION
A	ECN-CAP-0074936	2018/01/02	RELEASED TO PRODUCTION
B	ECN-CAP-0074942	2018/01/02	RELABEL WIRE COLOR
C	ECN-CAP-0076358	2023/02/03	CHANGED TOP FANS

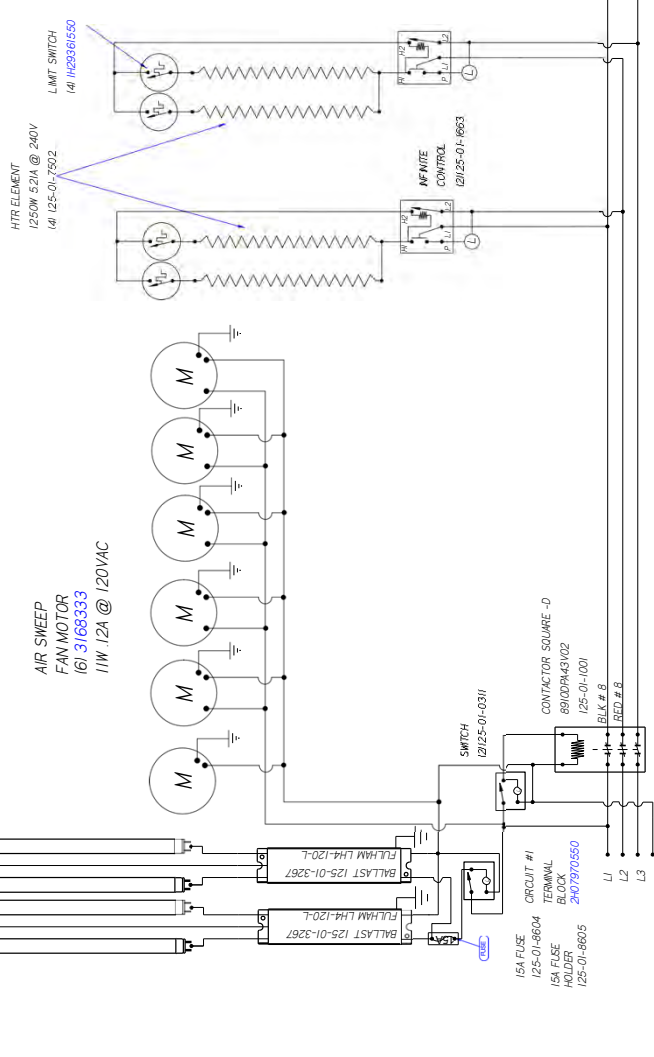
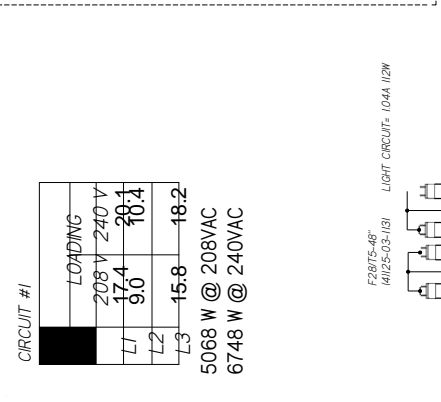
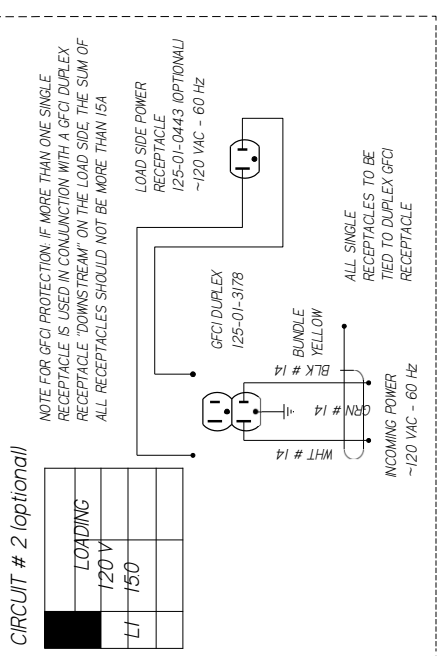

**HUSSMANN**  
DIAGRAM-Q-HC-10-S S-P

MATERIAL - NA  
DATE DRAWN - 10-2-18  
DRAWN BY - CRAIG BOOREY  
REVIEWED BY - CRAIG BOOREY  
APPROVED BY - CRAIG BOOREY

REF - SHEET 1 OF 1  
UNLESS OTHERWISE SPECIFIED DIMENSIONS ARE IN INCHES  
TOLERANCES ARE:  
DECIMALS .XX +0.3 .XXX  
ANGLES ± 2°  
PROJECTION

W6600459 | C

NOTE:  
CASE MUST BE GROUNDED  
WHEN PASSING WIRES THROUGH METAL HOLES A GROMMET MUST BE USED

REVISION HISTORY			
REV	ECN	DATE	DESCRIPTION
A	ECN-000-001132L	5-14-20	RELEASED TO PRODUCTION
B	ECN-000-001753B	2-6-23	CHANGED TOP FANS

REV	BY	CHKD	BY	APPR	BY

CIRCUIT #3	
LOADING	208 V
L1	150
L2	
L3	

NOTE FOR GFCI PROTECTION: IF MORE THAN ONE SINGLE RECEPTACLE IS USED IN CONJUNCTION WITH A GFCI DUPLEX RECEPTACLE "DOWNSTREAM" ON THE LOAD SIDE, THE SUM OF ALL RECEPTACLES SHOULD NOT BE MORE THAN 15A

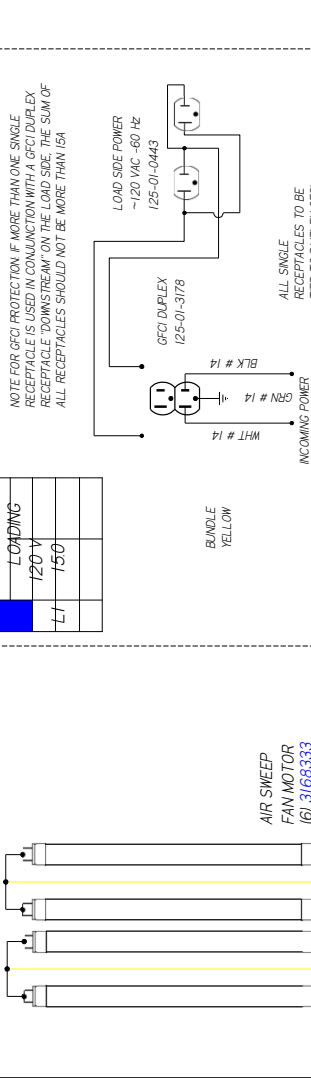
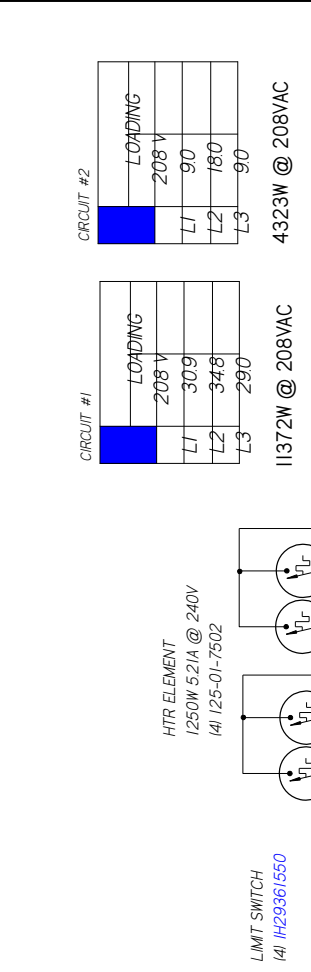

15A FUSE 125-01-8604  
15A FUSE HOLDER 125-01-8605

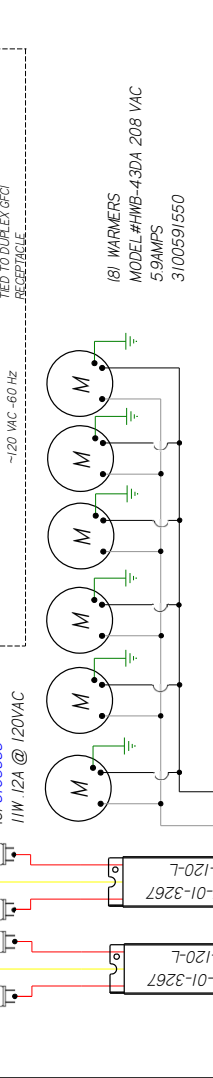
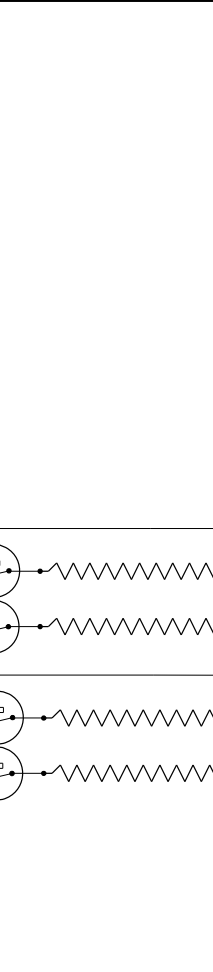

15A FUSE 125-01-8604  
15A FUSE HOLDER 125-01-8605

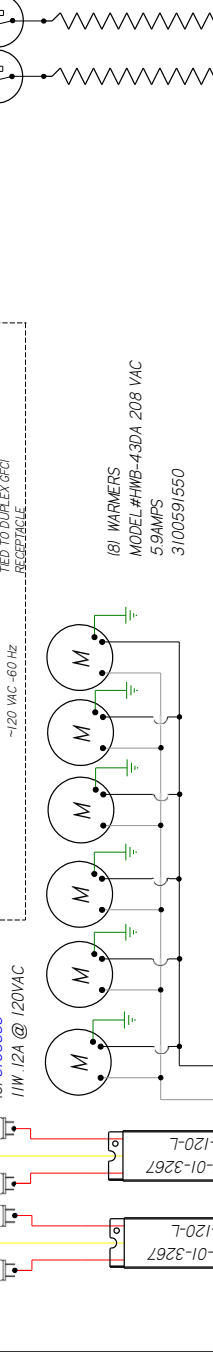

15A FUSE 125-01-8604  
15A FUSE HOLDER 125-01-8605

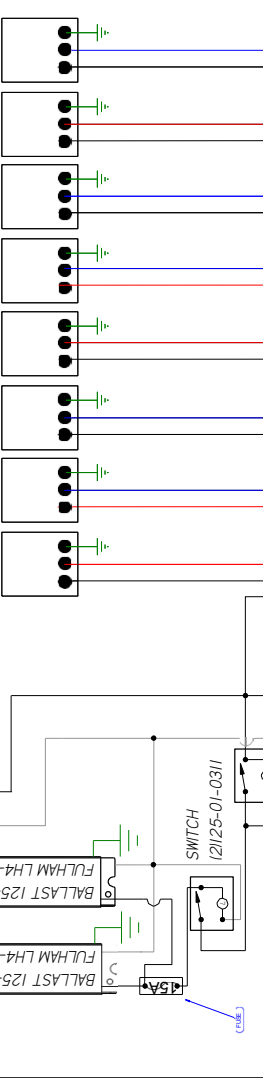
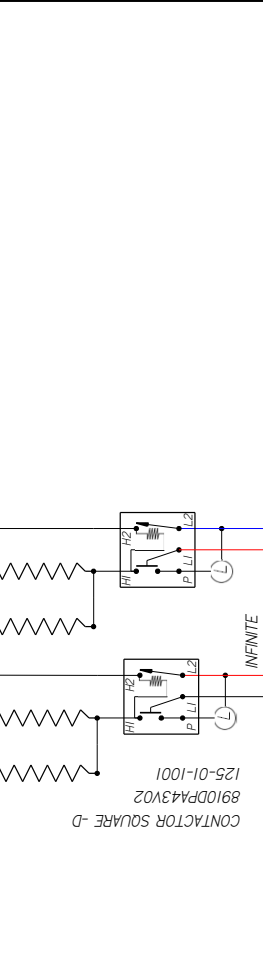

15A FUSE 125-01-8604  
15A FUSE HOLDER 125-01-8605

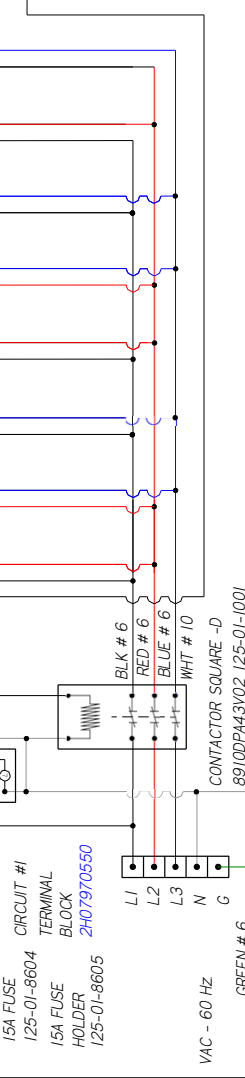
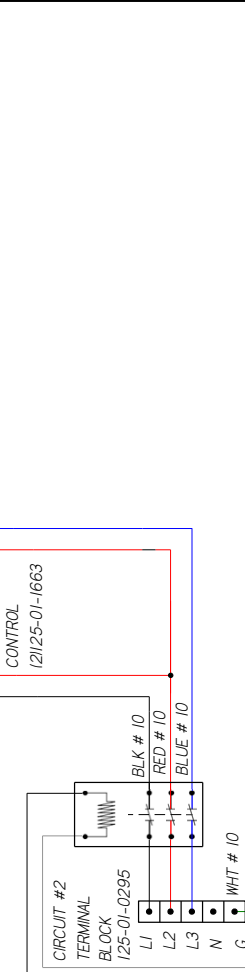

15A FUSE 125-01-8604  
15A FUSE HOLDER 125-01-8605

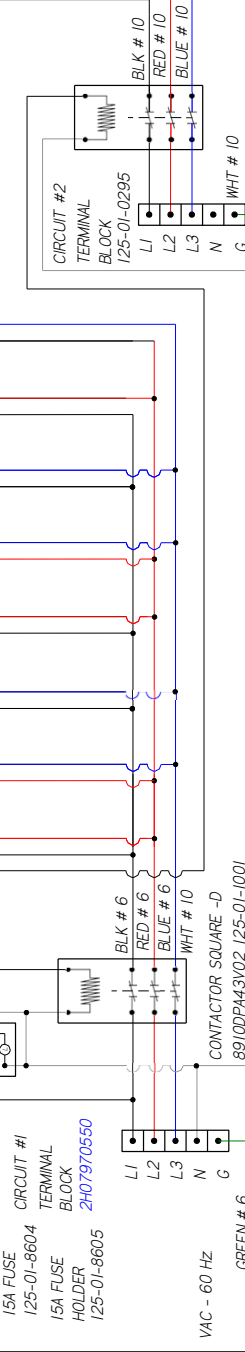

15A FUSE 125-01-8604  
15A FUSE HOLDER 125-01-8605

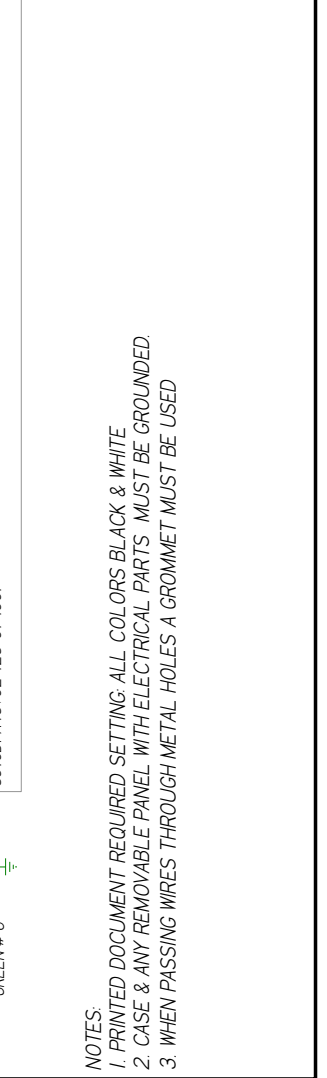
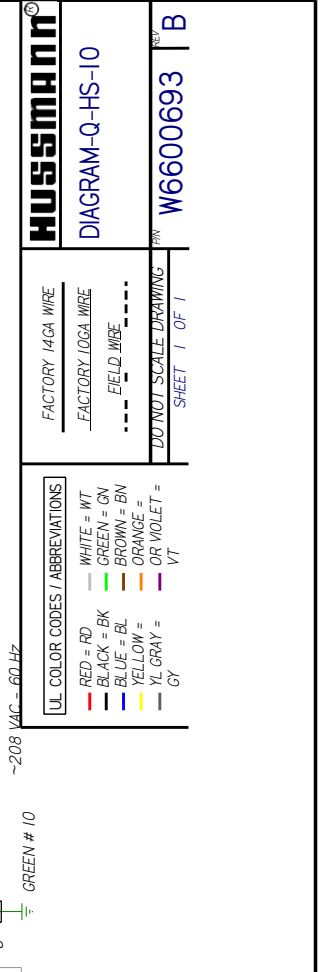

15A FUSE 125-01-8604  
15A FUSE HOLDER 125-01-8605

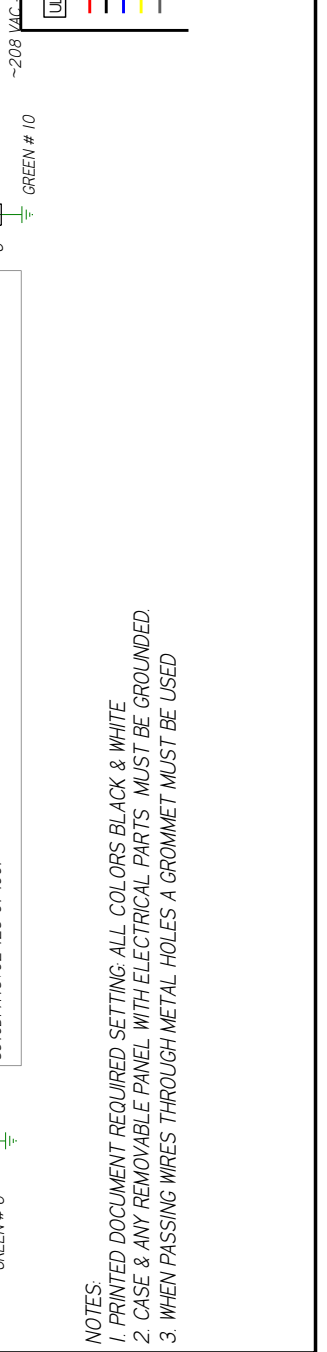
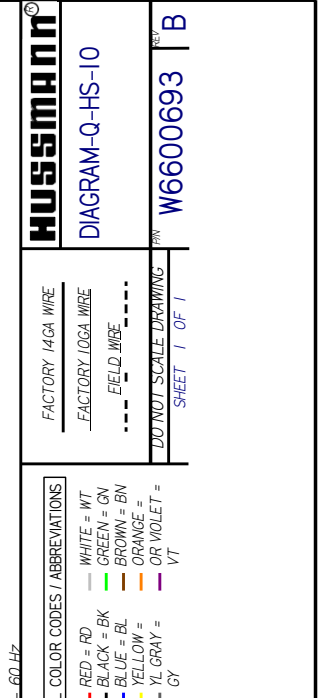

15A FUSE 125-01-8604  
15A FUSE HOLDER 125-01-8605

CIRCUIT #1	
LOADING	208 V
L1	309
L2	348
L3	290

CIRCUIT #2	
LOADING	208 V
L1	208
L2	90
L3	180
L3	90

4323W @ 208VAC  
11372W @ 208VAC

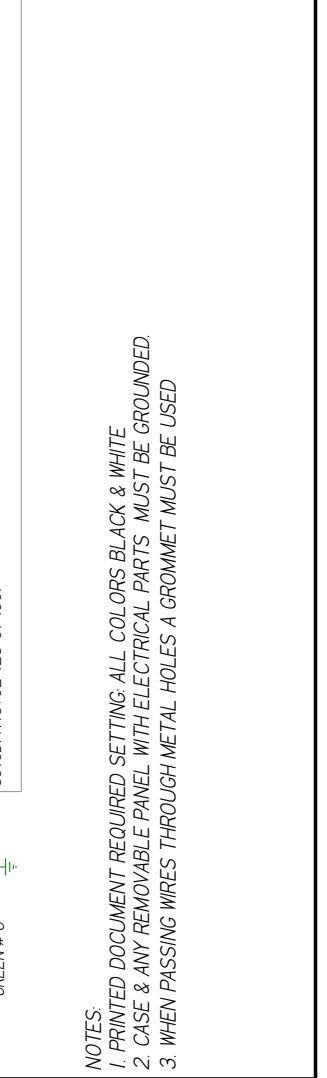

UL COLOR CODES / ABBREVIATIONS  
 RED = RD  
 BLACK = BK  
 BLUE = BL  
 YELLOW = YL  
 GRAY = GR  
 WHITE = WT  
 GREEN = GN  
 BROWN = BN  
 ORANGE = OR  
 VIOLET = VT

NOTES:  
 1. PRINTED DOCUMENT REQUIRED SETTING: ALL COLORS BLACK & WHITE  
 2. CASE & ANY REMOVABLE PANEL WITH ELECTRICAL PARTS MUST BE GROUNDED.  
 3. WHEN PASSING WIRES THROUGH METAL HOLES A GROMMET MUST BE USED

REVISION HISTORY			
REV	ECN	DATE	REVISION DESCRIPTION
B	ECN-000-0011328	6-17-20	REVISED CONTACTOR PART #
C	ECN-000-0017538	2-6-23	CHANGED TOP FANS

REV	BY	CHKD	BY	APPR	BY
CB	CB	CB	CB	CB	CB
CB	CB	CB	CB	CB	CB

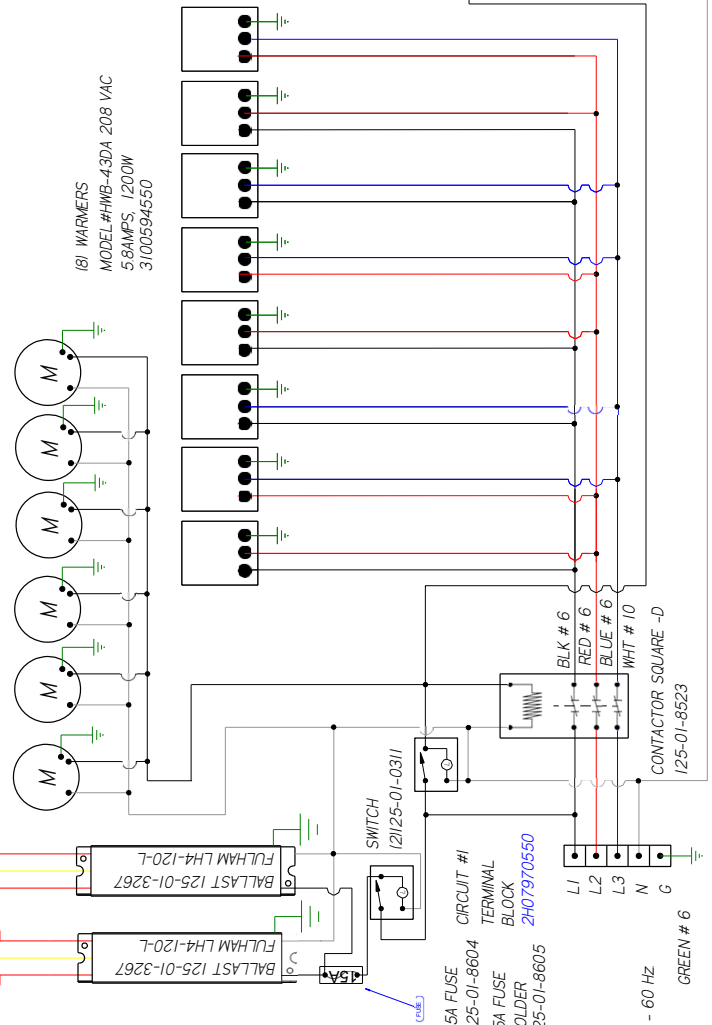
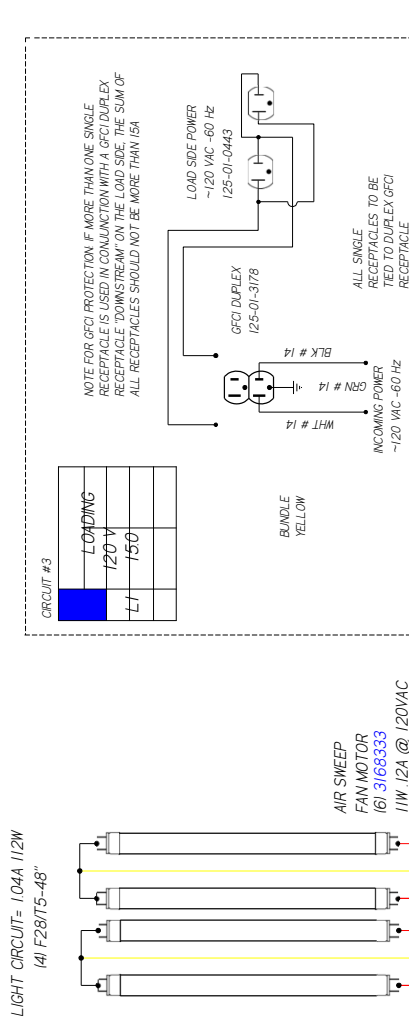

LIGHT CIRCUIT - 104A 112W  
141 F28175-48"

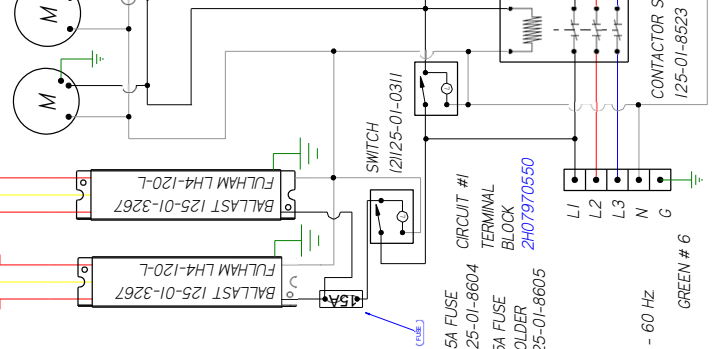
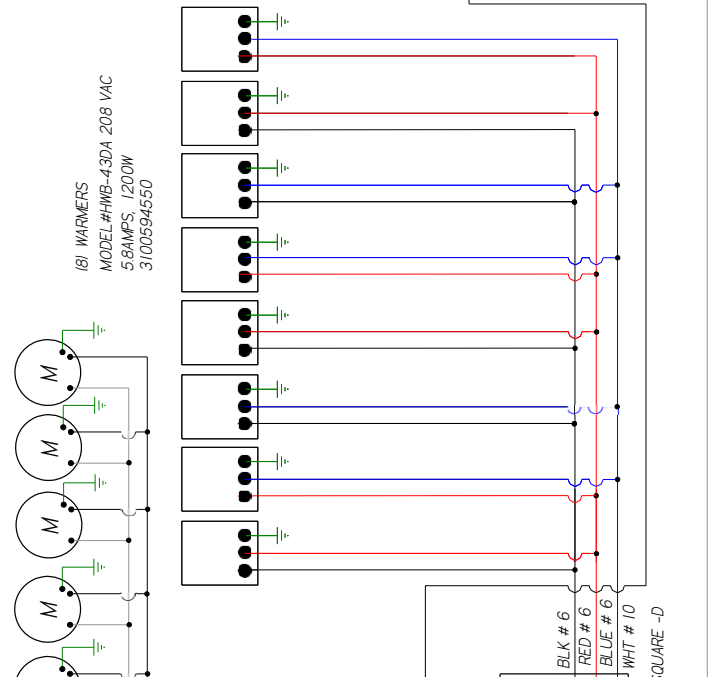
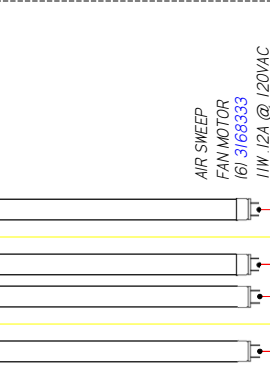
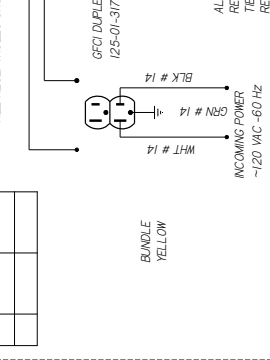
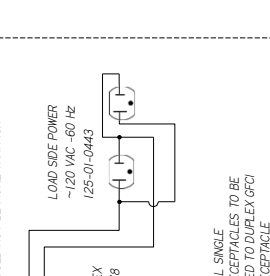

**HUSSMANN**  
DIAGRAM-Q-HC-10-  
H DRY WELLS

FACTORY 14GA WIRE  
FACTORY 10GA WIRE  
FIELD WIRE  
DO NOT SCALE DRAWING  
SHEET 1 OF 1

UL COLOR CODES / ABBREVIATIONS  
RED = RD  
BLACK = BK  
BLUE = BL  
YELLOW = YL  
GRAY = GR  
WHITE = WT  
GREEN = GN  
BROWN = BN  
ORANGE = OR  
OR VIOLET = VT

- NOTES:
1. PRINTED DOCUMENT REQUIRED SETTING. ALL COLORS BLACK & WHITE
  2. CASE & ANY REMOVABLE PANEL WITH ELECTRICAL PARTS MUST BE GROUNDED.
  3. WHEN PASSING WIRES THROUGH METAL HOLES A GROMMET MUST BE USED

W6600694  
REV C

**CIRCUIT #1**

LOADING
208 V
L1 229
L2 209

4767W @ 208VAC

LIGHT CIRCUIT= 104A 112W  
F28/75-48"

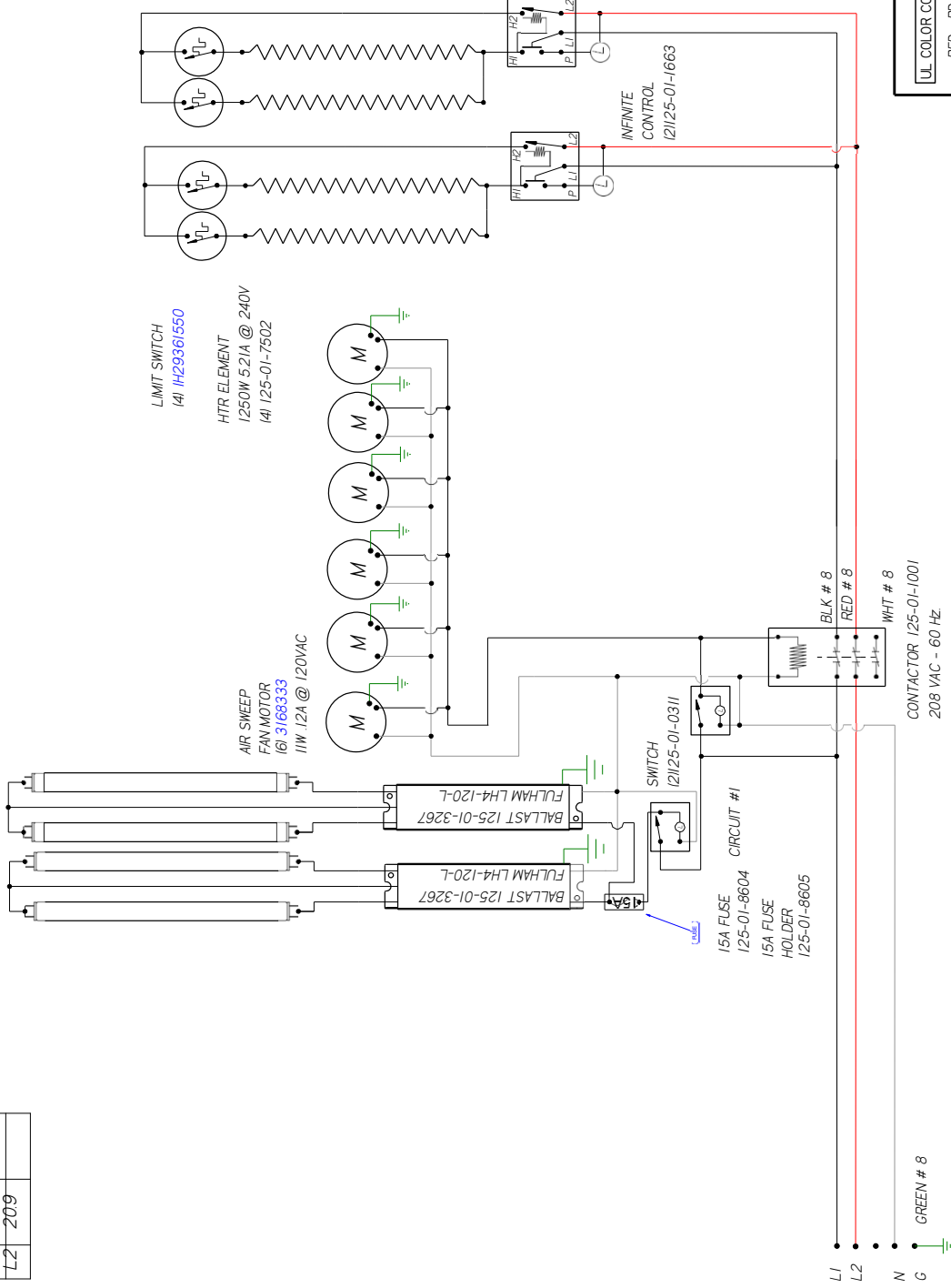

REV	ECN	DATE	REVISION DESCRIPTION	REV BY	CHKD BY	APPR BY
A	ECN-000-0011849	11-3-20	RELEASED TO PRODUCTION	CB	CB	CB
B	ECN-000-0017538	2-6-23	CHANGED TOP FANS	CB	CB	CB

**REVISION HISTORY**

CIRCUIT #4
LOADING
120 V
L1 150

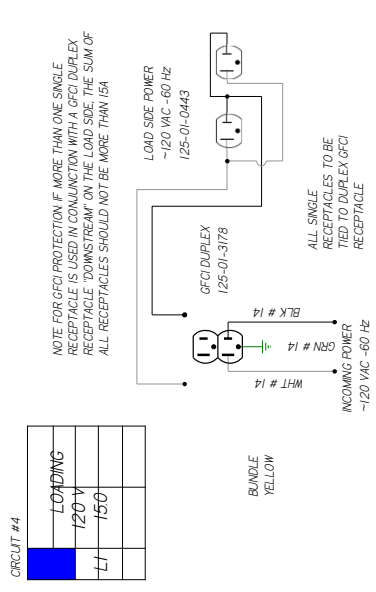

**HUSSMANN**  
**DIAGRAM-Q-HS-10**

FACTORY 14GA WIRE  
FACTORY 10GA WIRE  
FIELD WIRE  
DO NOT SCALE DRAWING  
SHEET 1 OF 2

**UL COLOR CODES / ABBREVIATIONS**

- RED = RD
- BLACK = BK
- BLUE = BL
- YELLOW = YL
- GRAY = GR
- WHITE = WT
- GREEN = GN
- BROWN = BN
- ORANGE = OR
- VIOLET = VT

- NOTES:**
1. PRINTED DOCUMENT REQUIRED SETTING. ALL COLORS BLACK & WHITE
  2. CASE & ANY REMOVABLE PANEL WITH ELECTRICAL PARTS MUST BE GROUNDED.
  3. WHEN PASSING WIRES THROUGH METAL HOLES A GROMMET MUST BE USED

CIRCUIT #2

0101	0102	0103	0104
0105	0106	0107	0108
0109	0110	0111	0112
0113	0114	0115	0116

2700 WATTS@208V

SHELF HEATER GRSBF-54 S  
6.5A 1350 WATTS @208V  
3076133550

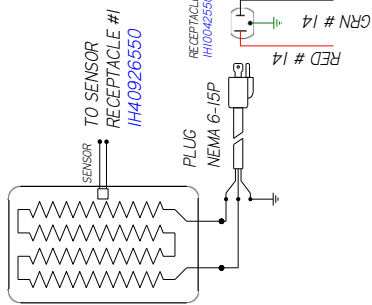

SHELF HEATER GRSBF-54 S  
6.5A 1350 WATTS @208V  
3076133550

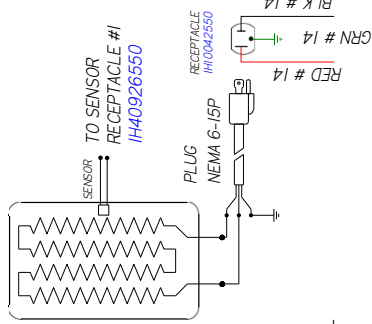

1 LEVEL CONTROL  
IH81658550

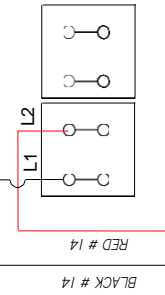

1 LEVEL CONTROL  
IH81658550

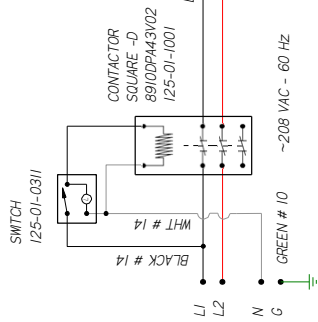
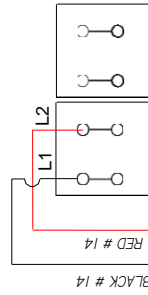

- NOTES:
1. PRINTED DOCUMENT REQUIRED SETTING. ALL COLORS BLACK & WHITE
  2. CASE & ANY REMOVABLE PANEL WITH ELECTRICAL PARTS MUST BE GROUNDED.
  3. WHEN PASSING WIRES THROUGH METAL HOLES A GROMMET MUST BE USED

**HUSSMANN**  
DIAGRAM-Q-HS-10

FACTORY 14GA WIRE  
FACTORY 10GA WIRE  
FIELD WIRE  
DO NOT SCALE DRAWING  
SHEET 2 OF 2

UL COLOR CODES / ABBREVIATIONS  
 RED = RD  
 BLACK = BK  
 BLUE = BL  
 YELLOW = YL  
 GRAY = GR  
 WHITE = WT  
 GREEN = GN  
 BROWN = BN  
 ORANGE = OR  
 VIOLET = VT

W6600733 | B

REVISION HISTORY			
REV	ECN	DATE	REVISION DESCRIPTION
A	ECN-000-0011850	11-5-20	RELEASED TO PRODUCTION
B	ECN-000-0017538	2-6-23	CHANGED TOP FANS

REV	BY	CHKD	BY
CB	CB	CB	CB
CB	CB	CB	CB

CIRCUIT #1	LOADING
L1	208 V
L2	229
L3	209

CIRCUIT #4	LOADING
L1	120 V
L2	150

4767W @ 208VAC  
F28/75-48"

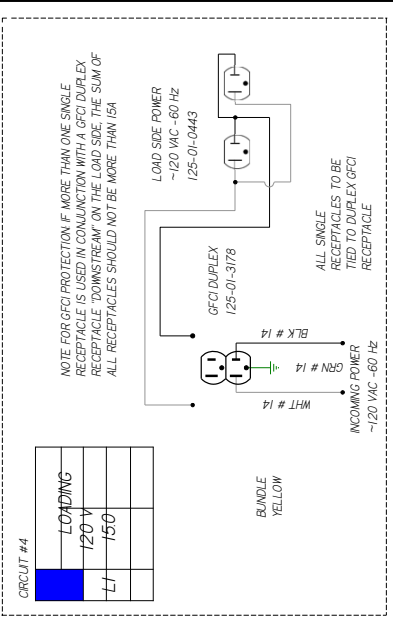
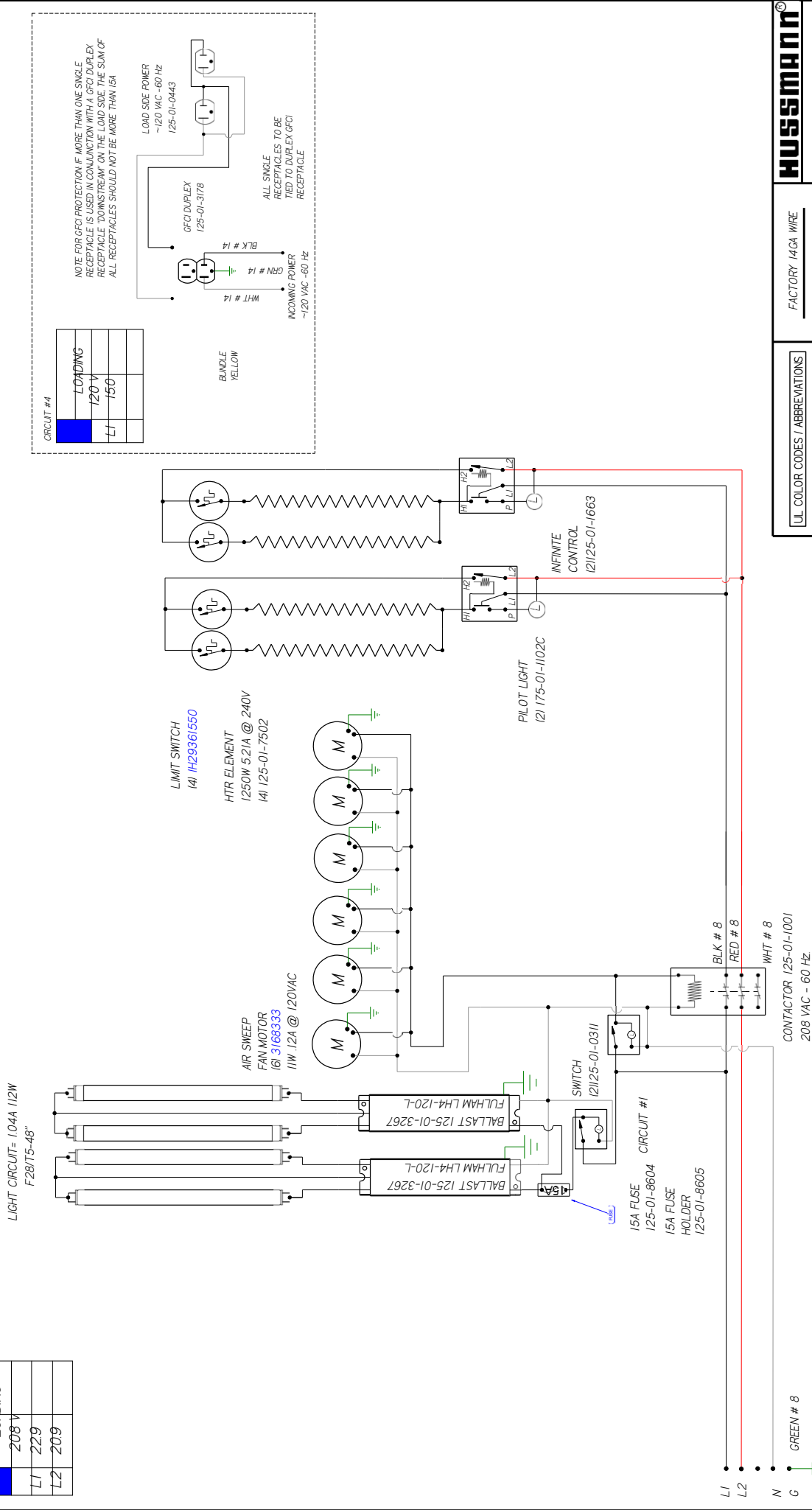

**HUSSMANN**  
DIAGRAM-Q-HS-10

FACTORY 14GA WIRE  
FACTORY 10GA WIRE  
FIELD WIRE  
DO NOT SCALE DRAWING  
SHEET 1 OF 3

UL COLOR CODES / ABBREVIATIONS  
 RED = RD  
 BLACK = BK  
 BLUE = BL  
 YELLOW = YL  
 GRAY = GR  
 WHITE = WT  
 GREEN = GN  
 BROWN = BN  
 ORANGE = OR  
 VIOLET = VT

NOTES:  
 1. PRINTED DOCUMENT REQUIRED SETTING. ALL COLORS BLACK & WHITE  
 2. CASE & ANY REMOVABLE PANEL WITH ELECTRICAL PARTS MUST BE GROUNDED.  
 3. WHEN PASSING WIRES THROUGH METAL HOLES A GROMMET MUST BE USED

CIRCUIT #2

WIRING				
208V				
L1				
L2				
L3				

48.15 WATTS @ 208V

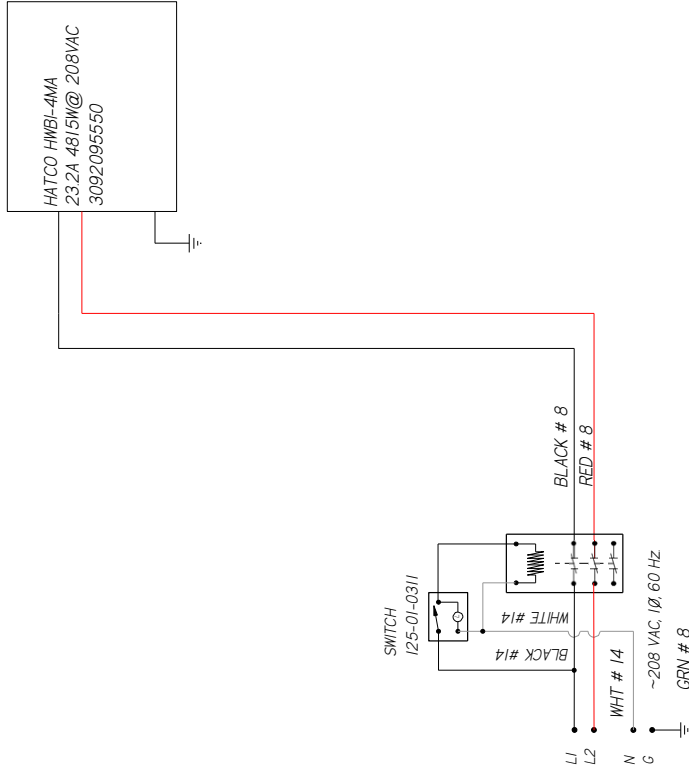

CIRCUIT #2

**HUSSMANN**

DIAGRAM-Q-HS-10

FACTORY 14GA WIRE  
 FACTORY 10GA WIRE  
 FIELD WIRE  
 DO NOT SCALE DRAWING  
 SHEET 2 OF 3

UL COLOR CODES / ABBREVIATIONS

RED = RD	WHITE = WT
BLACK = BK	GREEN = GN
BLUE = BL	BROWN = BN
YELLOW = YL	ORANGE = OR
GRAY = GR	VIOLET = VT

- NOTES:
1. PRINTED DOCUMENT REQUIRED SETTING: ALL COLORS BLACK & WHITE
  2. CASE & ANY REMOVABLE PANEL WITH ELECTRICAL PARTS MUST BE GROUNDED.
  3. WHEN PASSING WIRES THROUGH METAL HOLES A GROMMET MUST BE USED

W6600736 | B

REV

CIRCUIT #3

2015	2016	2017	2018	2019	2020
------	------	------	------	------	------

4815 WATTS @ .208V

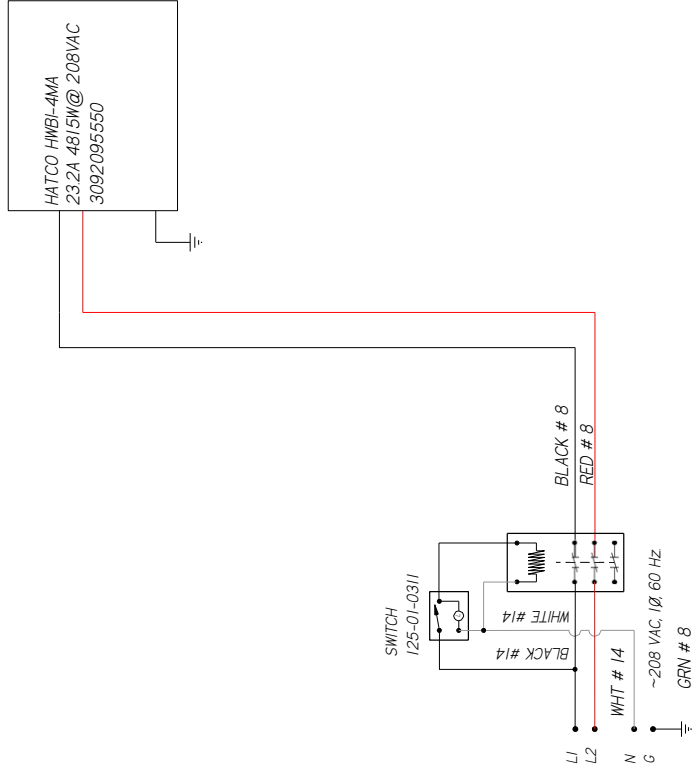

CIRCUIT #3

- NOTES:
1. PRINTED DOCUMENT REQUIRED SETTING: ALL COLORS BLACK & WHITE
  2. CASE & ANY REMOVABLE PANEL WITH ELECTRICAL PARTS MUST BE GROUNDED.
  3. WHEN PASSING WIRES THROUGH METAL HOLES A GROMMET MUST BE USED

<b>HUSSMANN</b> DIAGRAM-Q-HS-10	
FACTORY 14GA WIRE FACTORY 10GA WIRE FIELD WIRE	--- WHITE = WT --- GREEN = GN --- BROWN = BN --- ORANGE = OR --- VIOLET = VT --- GRN = GR --- YL = YL --- BL = BL --- BK = BK --- RD = RD
DO NOT SCALE DRAWING SHEET 3 OF 3	W6600736 B

CIRCUIT #1

LOADING	240
L1	200
L2	200
L3	200
N	200
G	200

88.4W @ 208VAC  
187.50W @ 240VAC

LIGHT CIRCUIT= 117A 120W

F21175-36"  
161125-03-1128

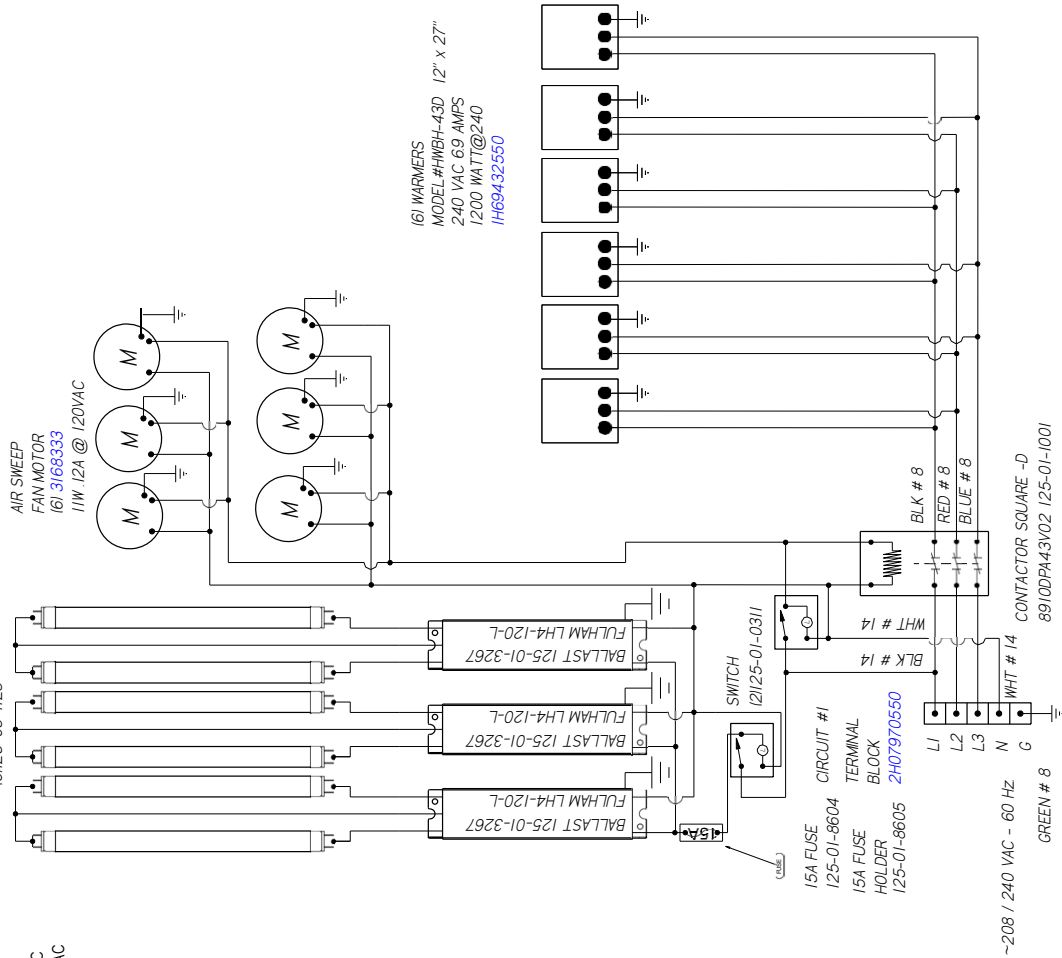

161 WARMERS  
MODEL #HMBH-43D 12' x 27"  
240 VAC 69 AMPS  
1200 WATT@240  
IH69432550

AIR SWEEP  
FAN MOTOR  
161 3168333  
11W, 12A @ 120VAC

~208 / 240 VAC - 60 HZ  
GREEN # 8  
CONTACTOR SQUARE -D  
8910DPA43V02 125-01-001

REV	ECN	DATE	REVISION DESCRIPTION	REV BY	CHKD BY	APPR BY
A	ECN-735331	2018/07/03	RELEASED TO PRODUCTION	CB	CB	CB
B	ECN-CAP-0007285	2017/04/10	CHANGED TERMINAL BLOCK	CB	CB	CB
C	ECN-CAP-0019686	2018/07/25	REVISED HOT WEL-AMPS, BALANCED LOADS	CB	CB	CB
D	ECN-CAP-0077338	2023/02/06	CHANGED TOP FANS	CB	CB	CB

REVISION HISTORY

MATERIAL - NA  
DATE DRAWN - 7/3/13  
DRAWN BY - CRAIG ROOREY  
REVIEWED BY - CRAIG ROOREY  
UNLESS OTHERWISE SPECIFIED DIMENSIONS ARE IN INCHES  
TOLERANCES ARE:  
DECIMALS .XX +0.3, .XXX  
±.010  
ANGLES ± .2°  
PROJECTION  
E  
ANG  
THRD  
DIAG SHEET 1 OF 2  
7.35331 REF - NEW  
ECN# -  
Q-HC-12-SV-W  
HUSSELMANN  
W6600085 | D

CIRCUIT #2

LOADING	240V	240
L1	100	210
L2	100	210
L3	100	210

6665W @ 208VAC  
8854W @ 240VAC

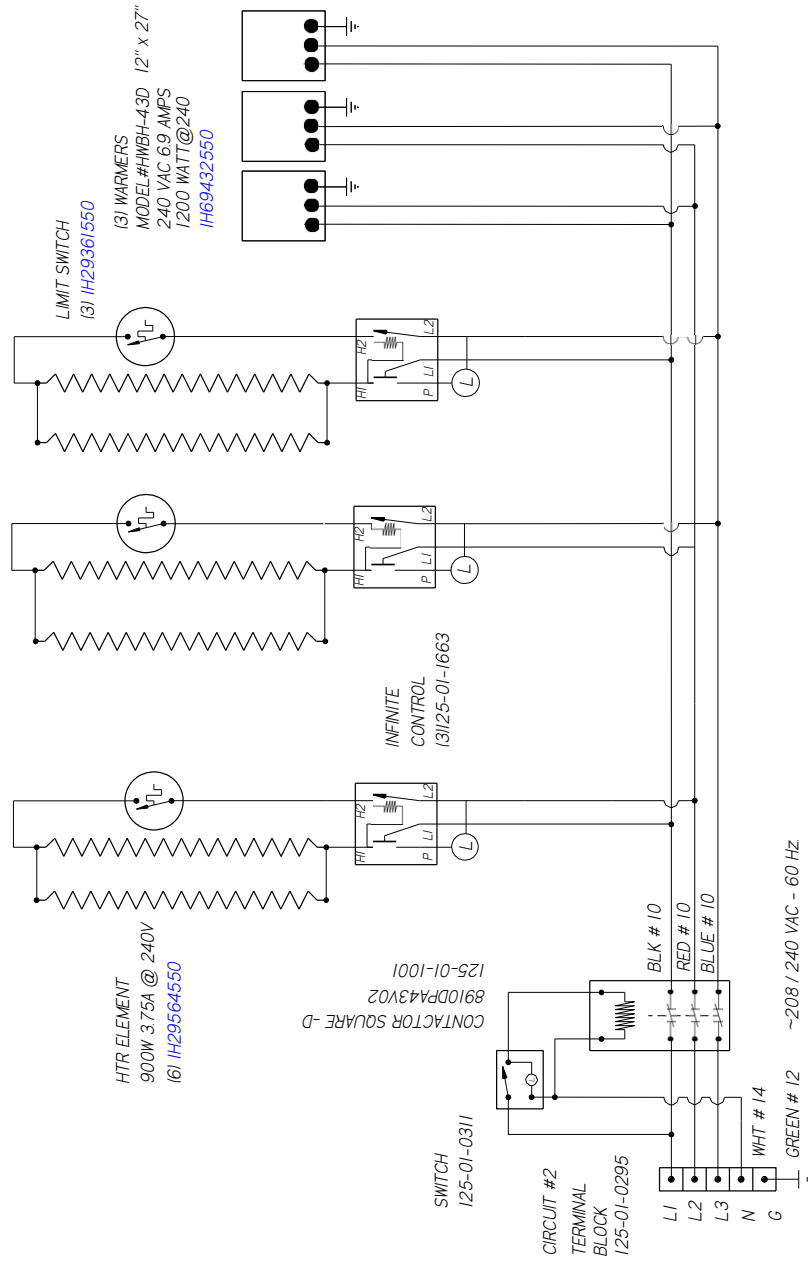

OPTIONAL SCALE STAND

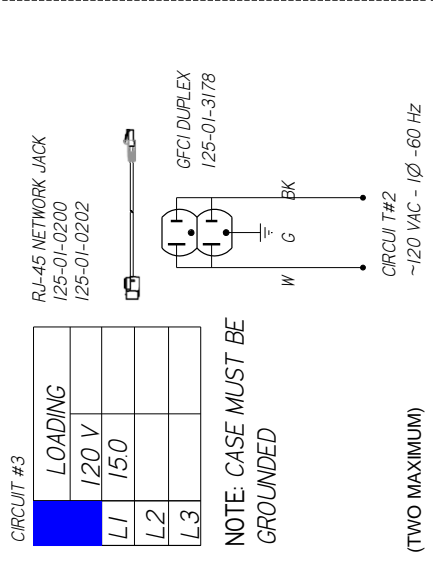

REV	ECN	DATE	REVISION DESCRIPTION	REV BY	CHKD BY	APPR BY
A	ECN-735331	2013/02/03	RELEASED TO PRODUCTION	CB	CB	CB
B	ECN-CAP-0007285	2017/04/10	CHANGED TERMINAL BLOCK	CB	CB	CB
C	ECN-CAP-0009865	2018/02/25	REVISED HOT WEL-AMPS, BLANKED LOADS	CB	CB	CB
D	ECN-CAP-0007538	2023/02/06	CHANGED TOP FANS	CB	CB	CB

MATERIAL - N/A

DATE DRAWN - 7/3/13

DRAWN BY - CRAIG BOOREY

REVIEWED BY - CRAIG BOOREY

APPROVED BY - CRAIG BOOREY

UNLESS OTHERWISE SPECIFIED DIMENSIONS ARE IN INCHES

TOLERANCES ARE:

DECIMALS .XX +0.3 .XXX

+0.0

ANGLES ± 2°

PROJECTION

ECN# - 735331 REF - NEW

DIAGRAM # 2 OF 2

THIRD ANGLE

**HUSSMANN**

**Q-HC-12-SV-W**

**W6600085** | D

NOTES:  
CASE MUST BE GROUNDED



REVISION HISTORY			
REV	EN	DATE	DESCRIPTION
A	EDY-CAP-0010804	2017/8/20	RELEASED TO PRODUCTION
A	EDY-COD-0017638	2023/02/06	CHANGED TOP FANS

CIRCUIT #2

LOADING	240V	240V
L1	200V	500V
L2	200V	500V
L3	200V	500V

8850W @ 208VAC  
1878W @ 240VAC

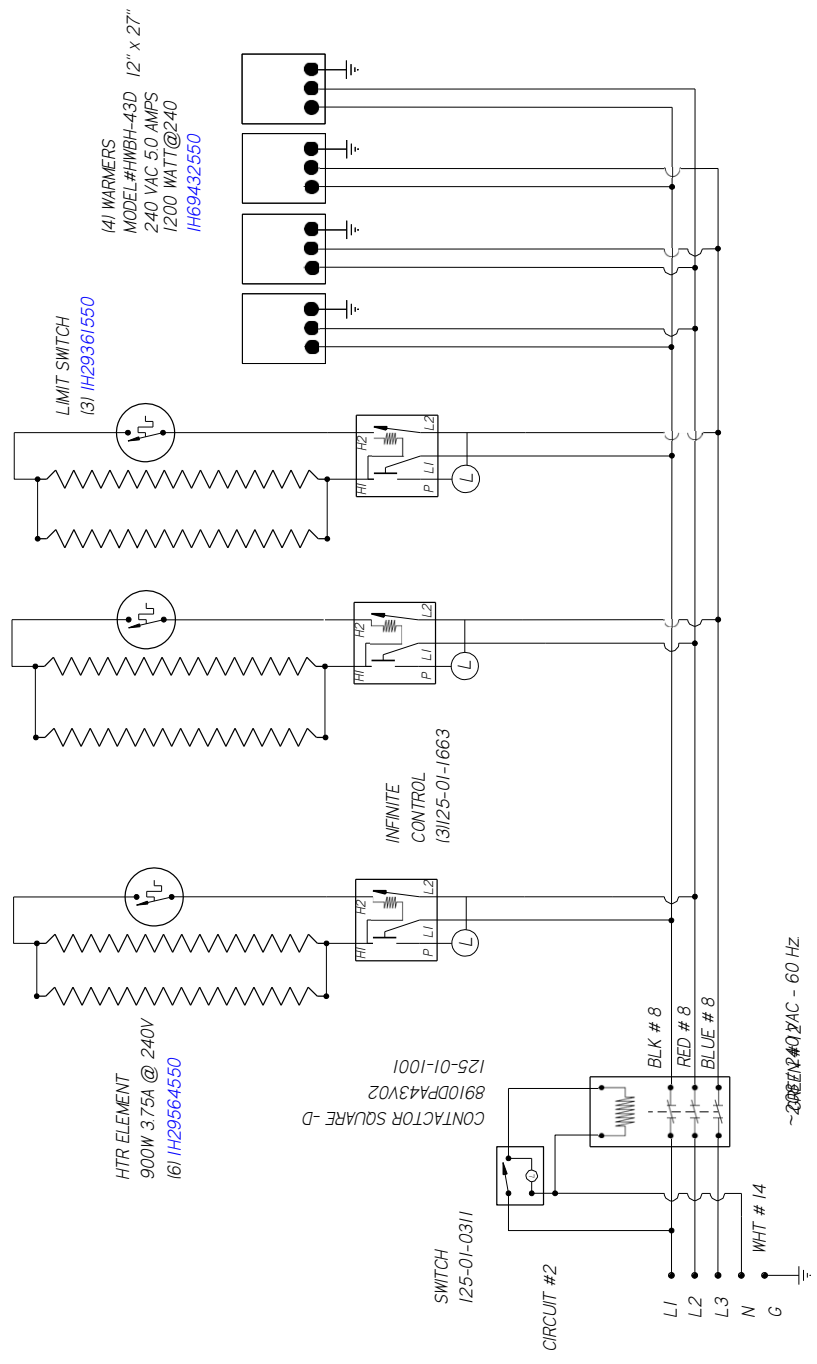

(4) WARMERS  
MODEL#HMBH-43D 12" x 27"  
240 VAC 5.0 AMPS  
1200 WATT@240  
IH69432550

HTR ELEMENT  
900W 3.75A @ 240V  
IH295664550

OPTIONAL SCALE STAND

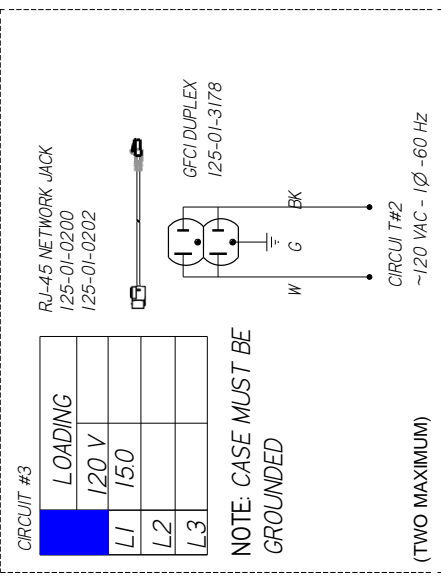

CIRCUIT #3	LOADING	120 V	150
L1			
L2			
L3			

NOTE: CASE MUST BE GROUNDED

(TWO MAXIMUM)

**HUSSMANN**  
DIAGRAM-Q-HC-1Z-S V-W

MATERIAL - NA  
DATE DRAWN - 12-1-17  
DRAWN BY - CRAIG BOOREY  
REVIEWED BY - CRAIG BOOREY  
APPROVED BY - CRAIG BOOREY  
UNLESS OTHERWISE SPECIFIED DIMENSIONS ARE IN INCHES  
TOLERANCES ARE:  
DECIMALS .XX +0.3 .XXX  
±.010

ECN-CAP-0010804 REF -  
SHEET 2 OF 2  
INCHES  
THIRD  
ANGL  
E  
PROJECTION

W6600345 | B

NOTES:  
CASE MUST BE GROUNDED  
WHEN PASSING WIRES THROUGH METAL HOLES A GROMMET MUST BE USED

REVISION HISTORY			
REV	ECON	DATE	REVISION DESCRIPTION
B	ECON-CAP-0019899	12-2-19	ADDED HOT WELL PART#
C	ECON-CAP-0017538	2-6-23	CHANGED TOP FANS

CIRCUIT #1	
WIRING	
200V	
202	
202	
202	
202	
8598W @ 208VAC	
3	

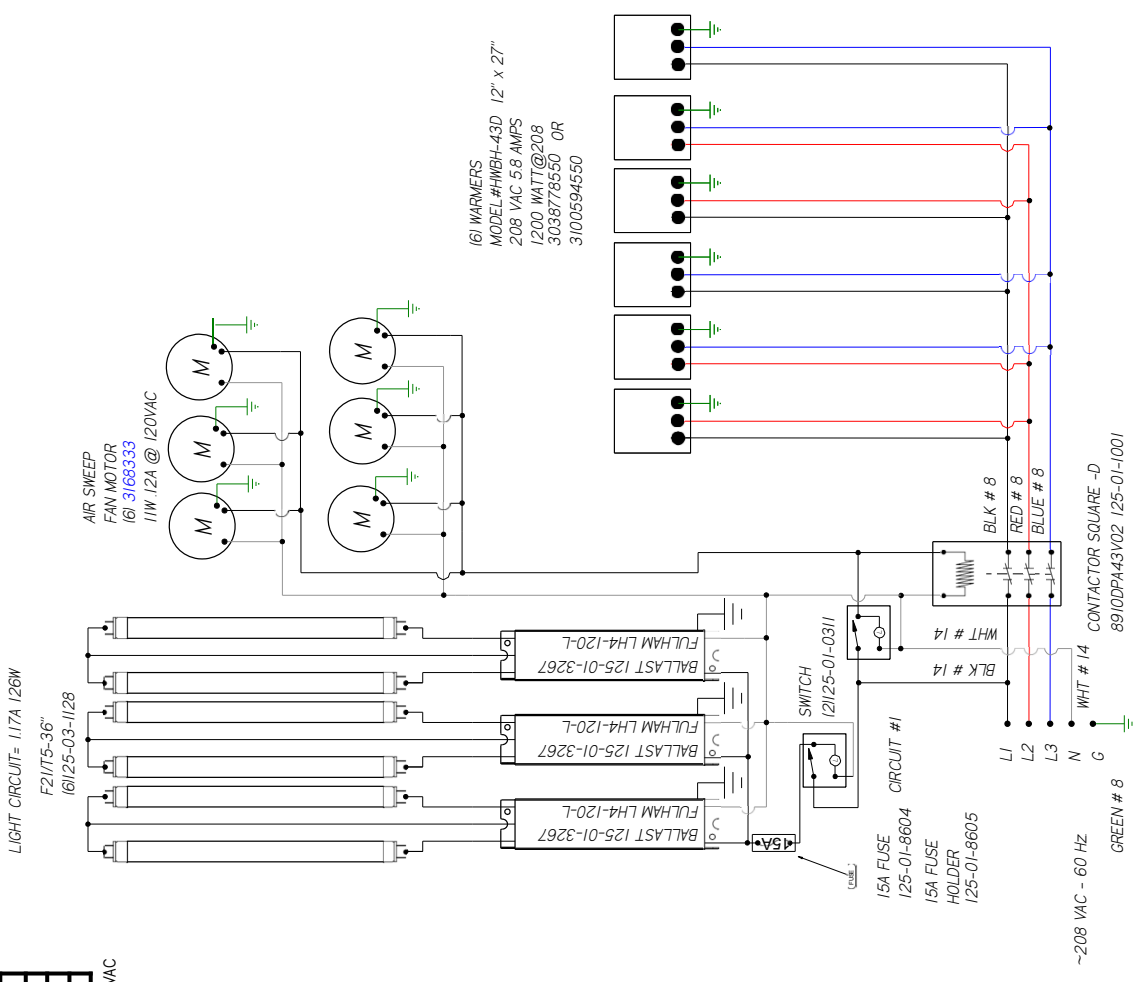

- NOTES:
1. PRINTED DOCUMENT REQUIRED SETTING: ALL COLORS BLACK & WHITE
  2. CASE & ANY REMOVABLE PANEL WITH ELECTRICAL PARTS MUST BE GROUNDED.
  3. WHEN PASSING WIRES THROUGH METAL HOLES A GROMMET MUST BE USED

UL COLOR CODES / ABBREVIATIONS	
RED = R1	WHITE = WT
BLACK = BK	GREEN = GN
BLUE = BL	BROWN = BN
YELLOW = YL	ORANGE = OR
GRAY = GY	VIOLET = VT

FACTORY 14GA WIRE	---
FACTORY 10GA WIRE	---
FIELD WIRE	---

DO NOT SCALE DRAWING	SCALE
SHEET 1 OF 2	

**HUSSMANN**  
**DIAGRAM-Q-HC-12-W**

W6600607  
 125

0.10 WIRE DIAGRAM SIZE C

CIRCUIT #2

LOADING	
120V	
15.0	
L1	
L2	
L3	

9563W @ 208VAC

3

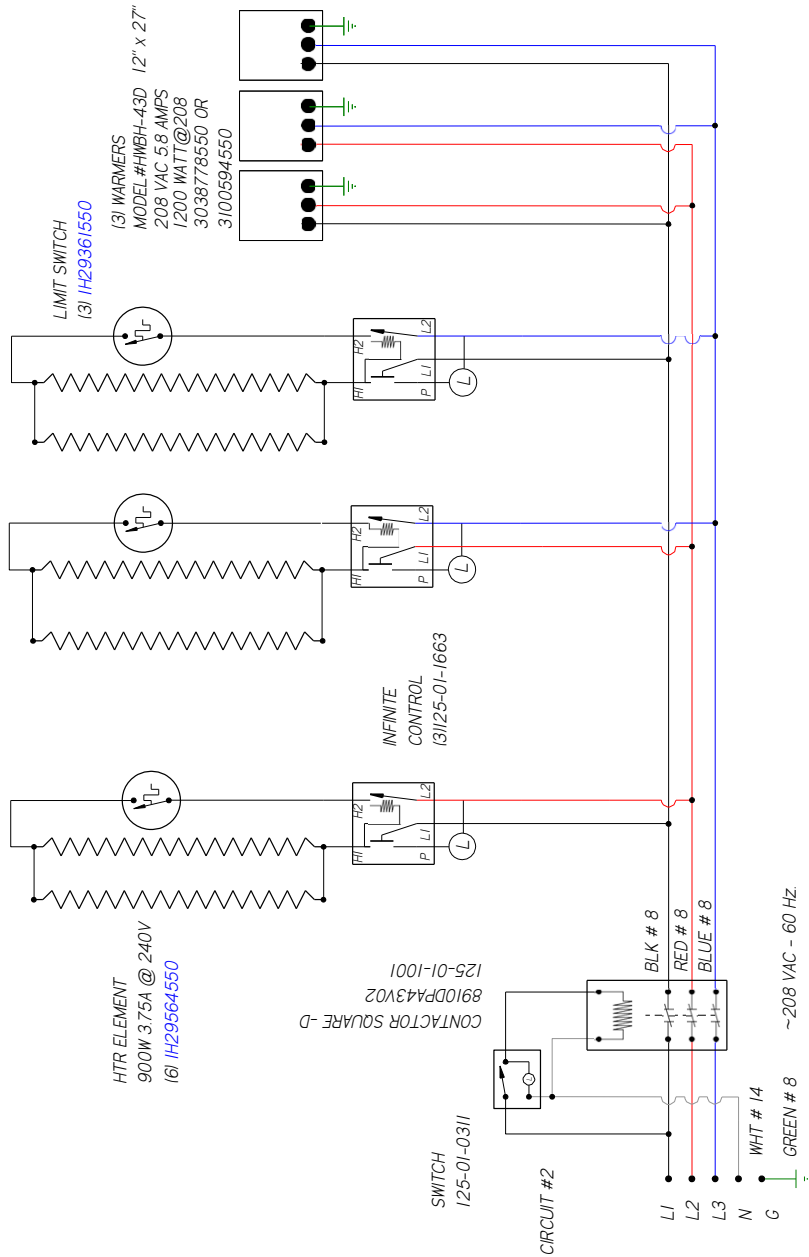

OPTIONAL SCALE STAND

CIRCUIT #3

LOADING	
120 V	
15.0	
L1	
L2	
L3	

NOTE: CASE MUST BE GROUNDED

(TWO MAXIMUM)

RJ-45 NETWORK JACK  
125-01-0200  
125-01-0202

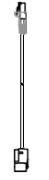

GFCI DUPLEX  
125-01-3178

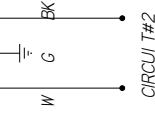

CIRCUIT #2  
~120 VAC - 1Ø - 60 Hz

UL COLOR CODES / ABBREVIATIONS

RED = RD	WHITE = WT
BLACK = BK	GREEN = GN
BLUE = BL	BROWN = BN
YELLOW = YL	ORANGE = OR
GRAY = GR	VIOLET = VT

FACTORY 14GA WIRE
FACTORY 10GA WIRE
FIELD WIRE
DO NOT SCALE DRAWING
SHEET 2 OF 2

- NOTES:
1. PRINTED DOCUMENT REQUIRED SETTING. ALL COLORS BLACK & WHITE
  2. CASE & ANY REMOVABLE PANEL WITH ELECTRICAL PARTS MUST BE GROUNDED.
  3. WHEN PASSING WIRES THROUGH METAL HOLES A GROMMET MUST BE USED

REV	ECN	DATE	REVISION DESCRIPTION	REV BY	CHKD BY	APPR BY
A	EDV-73331	2019/06/04	RELEASED TO PRODUCTION	CB	CB	CB
B	EDV-CA-000285	2017/04/10	CHANGED TERMINAL BLOCK	CB	CB	CB
C	EDV-CD-007638	2023/02/06	CHANGED TOP FANS	CB	CB	CB

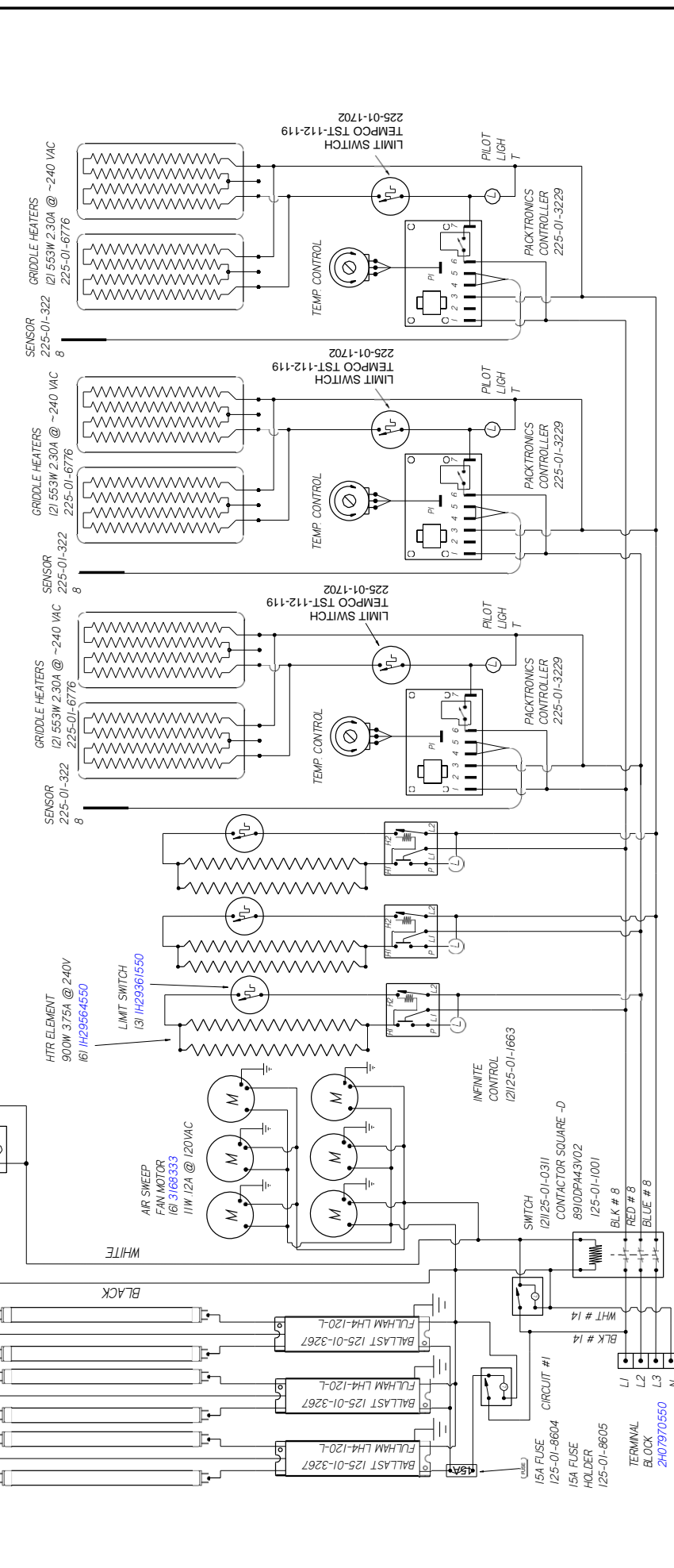
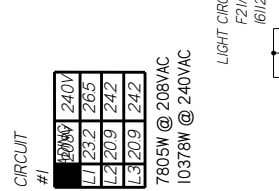
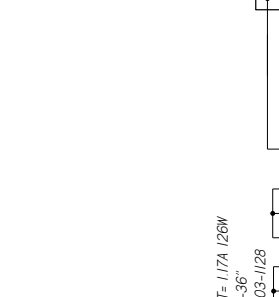
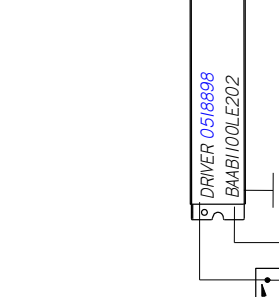
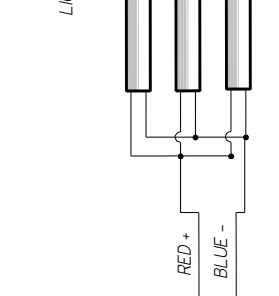
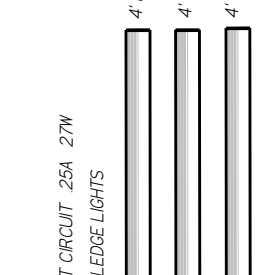

DATE DRAWN	6/14/13
DRAWN BY	- CRAIG BOOREY
REVIEWED BY	- CRAIG BOOREY
APPROVED BY	- CRAIG BOOREY
UNLESS OTHERWISE SPECIFIED DIMENSIONS ARE IN INCHES	
TOLERANCES ARE:	
THIRD ANGLE	
DECIMALS XX +0.3, XXX	
±0.0	
ANGLES ± 2°	
PROJECTION	

**HUSSMANN**  
**Q-HC-12-SV-P**  
**WLEDGE**  
**LIGHTS**

W6600082 | C

DATE DRAWN - 6/14/13  
 DRAWN BY - CRAIG BOOREY  
 REVIEWED BY - CRAIG BOOREY  
 APPROVED BY - CRAIG BOOREY  
 UNLESS OTHERWISE SPECIFIED DIMENSIONS ARE IN INCHES  
 TOLERANCES ARE:  
 THIRD ANGLE  
 DECIMALS XX +0.3, XXX  
 ±0.0  
 ANGLES ± 2°  
 PROJECTION

MATERIAL - NA  
 DATE DRAWN - 6/14/13  
 DRAWN BY - CRAIG BOOREY  
 REVIEWED BY - CRAIG BOOREY  
 APPROVED BY - CRAIG BOOREY  
 UNLESS OTHERWISE SPECIFIED DIMENSIONS ARE IN INCHES  
 TOLERANCES ARE:  
 THIRD ANGLE  
 DECIMALS XX +0.3, XXX  
 ±0.0  
 ANGLES ± 2°  
 PROJECTION

MATERIAL - NA  
 DATE DRAWN - 6/14/13  
 DRAWN BY - CRAIG BOOREY  
 REVIEWED BY - CRAIG BOOREY  
 APPROVED BY - CRAIG BOOREY  
 UNLESS OTHERWISE SPECIFIED DIMENSIONS ARE IN INCHES  
 TOLERANCES ARE:  
 THIRD ANGLE  
 DECIMALS XX +0.3, XXX  
 ±0.0  
 ANGLES ± 2°  
 PROJECTION

MATERIAL - NA  
 DATE DRAWN - 6/14/13  
 DRAWN BY - CRAIG BOOREY  
 REVIEWED BY - CRAIG BOOREY  
 APPROVED BY - CRAIG BOOREY  
 UNLESS OTHERWISE SPECIFIED DIMENSIONS ARE IN INCHES  
 TOLERANCES ARE:  
 THIRD ANGLE  
 DECIMALS XX +0.3, XXX  
 ±0.0  
 ANGLES ± 2°  
 PROJECTION

MATERIAL - NA  
 DATE DRAWN - 6/14/13  
 DRAWN BY - CRAIG BOOREY  
 REVIEWED BY - CRAIG BOOREY  
 APPROVED BY - CRAIG BOOREY  
 UNLESS OTHERWISE SPECIFIED DIMENSIONS ARE IN INCHES  
 TOLERANCES ARE:  
 THIRD ANGLE  
 DECIMALS XX +0.3, XXX  
 ±0.0  
 ANGLES ± 2°  
 PROJECTION

MATERIAL - NA  
 DATE DRAWN - 6/14/13  
 DRAWN BY - CRAIG BOOREY  
 REVIEWED BY - CRAIG BOOREY  
 APPROVED BY - CRAIG BOOREY  
 UNLESS OTHERWISE SPECIFIED DIMENSIONS ARE IN INCHES  
 TOLERANCES ARE:  
 THIRD ANGLE  
 DECIMALS XX +0.3, XXX  
 ±0.0  
 ANGLES ± 2°  
 PROJECTION

MATERIAL - NA  
 DATE DRAWN - 6/14/13  
 DRAWN BY - CRAIG BOOREY  
 REVIEWED BY - CRAIG BOOREY  
 APPROVED BY - CRAIG BOOREY  
 UNLESS OTHERWISE SPECIFIED DIMENSIONS ARE IN INCHES  
 TOLERANCES ARE:  
 THIRD ANGLE  
 DECIMALS XX +0.3, XXX  
 ±0.0  
 ANGLES ± 2°  
 PROJECTION

MATERIAL - NA  
 DATE DRAWN - 6/14/13  
 DRAWN BY - CRAIG BOOREY  
 REVIEWED BY - CRAIG BOOREY  
 APPROVED BY - CRAIG BOOREY  
 UNLESS OTHERWISE SPECIFIED DIMENSIONS ARE IN INCHES  
 TOLERANCES ARE:  
 THIRD ANGLE  
 DECIMALS XX +0.3, XXX  
 ±0.0  
 ANGLES ± 2°  
 PROJECTION

MATERIAL - NA  
 DATE DRAWN - 6/14/13  
 DRAWN BY - CRAIG BOOREY  
 REVIEWED BY - CRAIG BOOREY  
 APPROVED BY - CRAIG BOOREY  
 UNLESS OTHERWISE SPECIFIED DIMENSIONS ARE IN INCHES  
 TOLERANCES ARE:  
 THIRD ANGLE  
 DECIMALS XX +0.3, XXX  
 ±0.0  
 ANGLES ± 2°  
 PROJECTION

NOTES:  
 CASE MUST BE GROUNDED

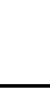

## 12. Troubleshooting Guide

Problem	Possible Cause	Possible Solution
<b>Product not holding temperature.</b>	Ambient conditions may be affecting the case operation.	Check case position in store. Is the case located near an open door, window, electric fan or air conditioning vent that may cause air currents? Case must be located minimum 15 Ft away from doors or windows. Cases are designed to operate at 55% Relative humidity and a temperature of 75°F.
	Unit not preheated.	Preheat case before loading product.
	Heat settings too low	Adjust shelf/griddle control setting.
	Low voltage.	Using volt meter make sure line voltage matches serial plate voltage.
	Product held too long	Hold product for recommended time.
	Product not placed correctly in case.	Place product in case per recommendations.
	Product not hot when placed in case.	Place prepackaged hot food in case.
<b>No shelf heat.</b>	Faulty shelf heater.	Check and replace if necessary.
	Faulty control.	Check and replace if necessary.
	Loose wiring on heater.	Check wiring/electrical connections.
	Temperature setting "Off".	Increase shelf heat setting.
<b>No griddle heat.</b>	Faulty griddle heater.	Check and replace if necessary.
	Faulty control.	Check and replace if necessary.
	Loose wiring on heater.	Check wiring/electrical connections.
	Temperature setting "Off".	Increase griddle heat setting.
<b>No hot/soup well heat.</b>	Faulty hot/soup well.	Check and replace if necessary.
	Loose wiring on hot/soup well.	Check wiring/electrical connections.
<b>Main Power switch on but case is inoperative.</b>	Open Circuit.	Check to see that cord is plugged in if plug is provided. Check wiring/electrical connections for hard wired cases. Check line voltage. Check power switch and replace if defective.
<b>Condensation on glass.</b>	Ambient conditions may be affecting the case operation.	Check case position in store. Is the case located near an open door, window, electric fan or air conditioning vent that may cause air currents? Case must be located minimum 15 Ft away from doors or windows. Cases are designed to operate at 55% Relative humidity and a temperature of 75°F.
	Inadequate air circulation.	Check if air sweep fans are functioning, check electrical connections.
	There is not enough heat provided in the airflow.	Check if air sweep heater is functioning, check electrical connections.
	There are glass gaps on the side of the case.	See glass adjustment section.
	Glass is not completely shut.	Close glass correctly.
	Calrods may not be working.	Check calrod operation.
	Well control setting is too high.	Check that well setting is not above "7" on control knob.

## Troubleshooting (Cont'd)

Problem	Possible Cause	Possible Solution
<b>Large gap is visible on bottom of front glass or glass can't be opened because it is too low.</b>	Glass Height adjusters need to be adjusted.	See Glass Adjustment section.
<b>Large gaps are visible in between glass panels or glass rubs against end panel.</b>	Glass/glass clamp assembly needs to be adjusted.	See Glass Adjustment section.
<b>Front glass does not stay open and falls closed.</b>	Glass shock/piston may need to be replaced.	Case should be serviced by a qualified service technician.
<b>Lights do not come on.</b>	Ballast/light socket wiring.	Check electrical connections. See Electrical Section and check wiring diagram.
	Ballast needs to be replaced.	Case should be serviced by a qualified service technician. See Electrical Section.
	Lamp socket needs to be replaced.	Case should be serviced by a qualified service technician.
	Lamp needs to be replaced.	See Maintenance Section.
	Light Switch needs to be replaced.	Case should be serviced by a qualified service technician.

## 13. Appendices

### Appendix A. - Temperature Guidelines

- 1.0 Hot cases are tested to maintain all hot food at 140°F - 150°F. These cases are not designed to heat up or cook food. It is the user's responsibility to stock the hot food cases immediately after the cooking of the food with a pulp temperature of at least 150°F to 160°F.

### Appendix B. - Application Recommendations

- 1.0 The installer should perform a complete start-up evaluation prior to the loading of food into the hot food case, which includes such items as:
- a) Initial temperature performance, Griddles and Hot Wells.
  - b) Observation of outside influences such as drafts, radiant heating from the ceiling and from lamps. Such influence should be properly corrected or compensated.
  - c) Complete start-up procedures should include
    1. Heat/display lamps are lighting.
    2. Indicator lamps on control panel(s) are working
    3. Auto-fill is functioning properly (Service cases)
    4. Hot Griddles are functioning.

### Appendix C. - Field Recommendations

- 1.0 The most consistent indicator of display hot case performance is temperature of the product itself.

**NOTE:** Public Health will use the temperature of the product in determining if the hot case will be allowed to display potentially hazardous food. For the purpose of this evaluation, product temperature above the FDA Food Code 1993 temperature for potentially hazardous food will be the first indication that an evaluation should be performed. It is expected that all hot case will keep food at the FDA Food Code 1993 temperature for potentially hazardous food.

1. The following recommendations are made for the purpose of arriving at easily taken and understood data which, coupled with other observations, may be used to determine whether a hot case is working as intended:
  - a) **INSTRUMENT** - A stainless steel stem-type thermometer is recommended and it should have a dial a minimum of 1 inch internal diameter. A test thermometer scaled only in Celsius or dually scaled in Celsius and Fahrenheit shall be accurate to 1°C (1.8°F). Temperature measuring devices that are scaled only in Fahrenheit shall be accurate to 2°F. The thermometer should be checked for proper calibration. (It should read 32°F when the stem is immersed in an ice water bath).
  - b) **LOCATION** - The thermometer must be inserted into the food itself to acquire proper food pulp temperature.
  - c) **READING** - The thermometer reading should be made only after it has been allowed to stabilize, i.e., maintain a constant reading. Loading Product: Cases should be allowed to heat up for one hour before product is loaded. Temperature adjustments: Allow 4 hours after adjustment has been made before testing pulp temperature of product.
  - d) **OTHER OBSERVATIONS** - Other observations should be made which may indicate operating problems, such as unsatisfactory product, feel/appearance.

---

## Appendices (Cont'd)

### Appendix D. - Recommendations to User

- 1.0 Hussmann has provided instructions and recommendations for proper periodic cleaning. The user will be responsible for such cleaning, including the cleaning of equipment within the compartment and the hot area(s). Cleaning practices, particularly with respect to proper refrigerator unloading and warm-up, must be in accordance with applicable recommendations.
  1. Allow the case to preheat for one hour prior to loading.
  2. Hot foods should enter the case directly after cooking or no lower than 150° - 160°F. The Hot Cases are not designed to heat up or cook food.
  3. Self Service - be sure to display product in single layer in direct contact with heating surface.
  4. All griddle type units are designed to maintain temperatures above the FDA guideline of 140°F. This is product temperature, not air or griddle temperature. Due to the open design of these units, they must be loaded with product for proper operation. When units are empty, they experience rapid rise of heated air from air outside the case. This action gives empty units a false, lower than desired, temperature reading. Loading the case traps the air at the griddle, raising temperatures to the 165°F to 185°F range, keeping product well above the FDA guidelines. Remember, these units must be loaded with product to maintain safe product temperature.
  5. Check the food pulp temperature frequently with a thermometer to make sure it is at the proper holding temperature. Hot foods should be at 140°F. The thermometer must be inserted into the food itself for the proper temperature.
  6. Do not display more food than will be sold within a 4 hour period.
  7. When restocking, bring older food to the front.
  8. Clean spills as soon as they happen.
  9. Fingerprints and food splatter will drastically shorten bulb life. Clean splatter off the bulbs immediately with a soft cloth. When handling bulbs, wear cotton gloves or use a cotton rag/towel.
  10. When "freshening" foods such as macaroni and cheese with added water, heat the water in a clean container until it is 10°F to 20°F above the desired holding temperature of the food. This will keep the food at a safe serving temperature. Depending on the amount of water, the temperature can drop 10°F to 20°F in as little as five minutes.
  11. When transferring hot foods in the heated merchandiser to clean pans, preheat the clean pan. Transferring hot foods to room temperature pans can cause the temperature of the food to drop 20°F or more thus causing food to be at an unsafe serving temperature.
  12. Clean spills as they happen simply by wiping with a cloth. Be sure to use a dry cloth on very hot surfaces to prevent steam burns.

For further technical information, please log on to <http://www.hussmann.com/products/QH.htm> or <http://www.hussmann.com/products/QH.htm>



---

This warning does not mean that Hussmann products will cause cancer or reproductive harm, or is in violation of any product-safety standards or requirements. As clarified by the California State government, Proposition 65 can be considered more of a ‘right to know’ law than a pure product safety law. When used as designed, Hussmann believes that our products are not harmful. We provide the Proposition 65 warning to stay in compliance with California State law. It is your responsibility to provide accurate Proposition 65 warning labels to your customers when necessary. For more information on Proposition 65, please visit the California State government website.

---

### Service Record

Last service date:      By:

_____	_____
_____	_____
_____	_____
_____	_____
_____	_____
_____	_____
_____	_____
_____	_____

---

## **HUSSMANN**<sup>®</sup>/Chino

Additional copies of this publication may be obtained by contacting:  
 Hussmann® Chino  
 13770 Ramona Avenue • Chino, California 91710  
 (909) 628-8942 FAX  
 (909) 590-4910  
 (800) 395-9229

**[www.hussmann.com](http://www.hussmann.com)**

The *MODEL NAME* and *SERIAL NUMBER* is required in order to provide you with the correct parts and information for your particular unit. They can be found on a small metal plate on the unit. Please note them below for future reference.

**MODEL:**

**SERIAL NUMBER:**

---