

We reserve the right to change or revise specifications and product design in connection with any feature of our products. Such changes do not entitle the buyer to corresponding changes, improvements, additions or replacements for equipment previously sold or shipped.

Item	Part #	Description	Wiring Item #
<b>FAN ASSEMBLIES, AND THERMOSTATS</b>			
(A)	0477656	Standard Energy Efficient Fan Motor, Evaporator (MO.4410547)	(1)
	0142780	Fan Blade Embossing toward motor (FB.0142780)	

Data sheet-Excel-PWEE

**Note:** Revision C: Added high glide refrigerant note. Other changes marked by bar, underline or circle.

# Engineering Plan Views

## PHYSICAL DATA

Merchandiser Drip Pipe (in.)	1 1/2
Merchandiser Liquid Line (in.)	3/8
Merchandiser Suction Line (in.)	7/8

### End Case for 86 Inch Produce Wide Island

11-2010

Dimensions are shown as inches & (mm).

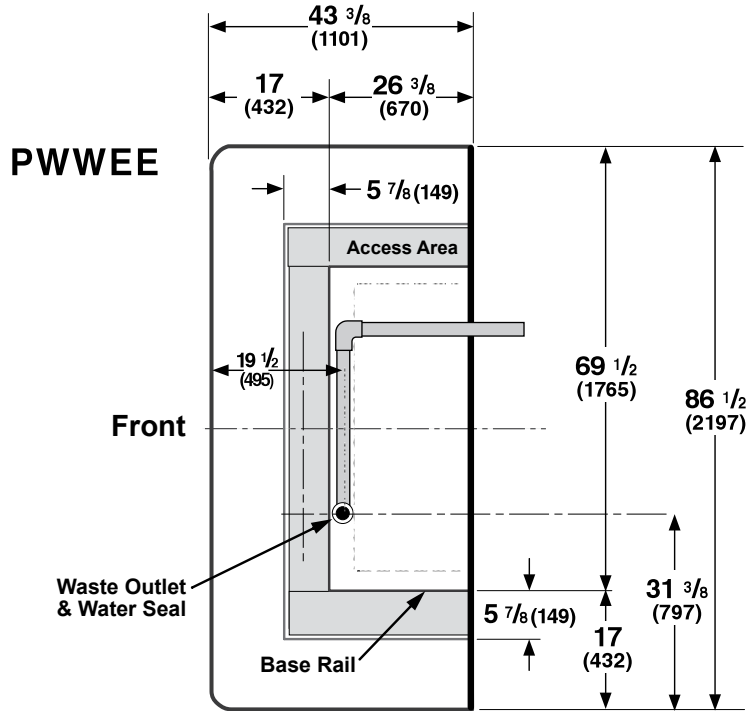

General	END PWEE
Maximum outside dimension of case side to side <i>(includes bumper)</i> <i>Each Partition adds 1 1/2 in. (38 mm) to the length of the lineup.</i>	86 1/2 (219)
Width of case	43 3/8 (1101)
Front of base rail to rear of case	26 3/8 (670)
Front of case to outside edge of base rail	17 (432)
Front of splashguard to outside edge of base rail	5 7/8 (149)
Width of base rail	2 1/8 (54)
Access area between front of base rail and splashguard	4 7/8 (124)
<b>Waste Outlet</b>	
Front outside edge of case to center of waste outlet	19 1/2 (495)
Right outside edge of case to center of waste outlet	31 3/8 (797)



Hussmann refrigerated merchandisers configured for sale for use in the United States meet or surpass the requirements of the DOE 2017 energy efficiency standards.

Dimensions are shown as inches & (mm).

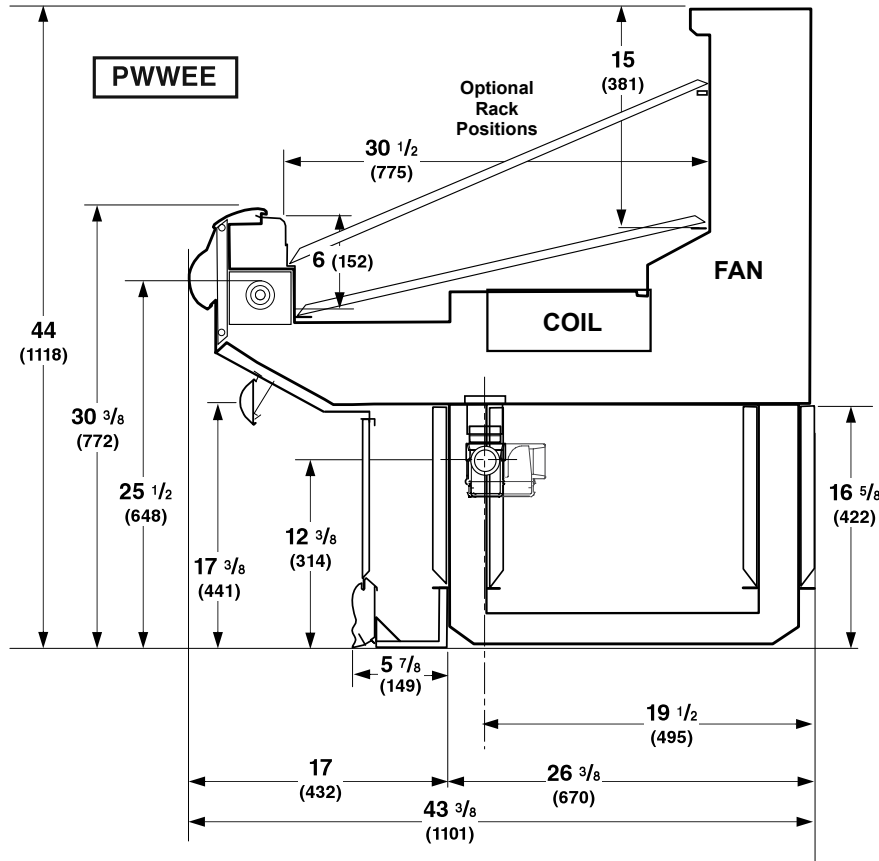

**PHYSICAL DATA**

**Estimated Charge (lb)\*\***

PWWEE 1.1 lb 18 oz 1.1 kg

\*\*This is an average for all refrigerant types. Actual refrigerant charge may vary by approximately 0.5 lb (8 oz / 0.2 kg).

**NSF Certification**

This merchandiser model is manufactured to meet NSF/ANSI (National Sanitation Foundation) Standard #7 requirements for construction, materials & cleanability.

**REFRIGERATION DATA**

**Note:** This data is based on store temperature and humidity that does not exceed 75°F and 55% R.H.

	PWWEE§
Discharge Air (°F)	32
Evaporator(°F)	24
Unit Sizing (°F)	22

§ Average evaporator temperature shown. Use dew point for high glide refrigerants for unit sizing. Care should be taken to use the dew point in PT tables for measuring and adjusting superheat. Adjust evaporator pressure as needed to maintain discharge air temperature shown.

Btu/hr/case	PWWEE
Parallel	2725
Conventional	3005

**DEFROST DATA**

	PWWEE
Frequency (hr)	6
Defrost Water (lb/ft/day)	8

(± 15% based on case configuration and product loading).

OFFTIME	PWWEE
Temp Term (°F)	N/A
Failsafe (minutes)	45
Standard Defrost Thermostat	N/A

**CONVENTIONAL CONTROLS**

Low Pressure Backup Control	
C/I/CO*	17°/17° F

Indoor Unit Only, Pressure Defrost	
Termination*	48° F

\*Use a Temperature Pressure Chart to determine PSIG conversions.

**Electrical Data**

<b>Number of Fans</b>	<b>PWWEE</b>
<b>Refrigeration — <u>13W</u></b>	<b>1</b>
<b>Refrigeration — <u>13W</u> (Export)</b>	<b>1</b>

	<b>Amperes</b>	<b>Watts</b>
<b>Merchandiser</b>	<b>PWWEE</b>	<b>PWWEE</b>
<b>Fans (Refrigeration)</b>		
Energy Efficient (120V 60Hz)	0.33	20
Export (230V 50 Hz)	0.47	70

<b>Minimum Circuit Ampacity</b>	
With Energy Efficient Fans (120V 60Hz)	0.53
With Export Fans (230V 50 Hz)	0.67

<b>Maximum Over Current Protection 120V</b>	20
<b>Maximum Over Current Protection 230V</b>	15

**Standard Lighting**

None

**Optional Lighting**

None

**Optional Shelf Lighting**

None

## Product Data

<i>Recommended Usable Cube</i> <sup>1</sup> (Cu Ft/Case)	10.55 ft <sup>3</sup> /case (0.30 m <sup>3</sup> /case)
<i>AHRI Total Display Area</i> <sup>2</sup> (Sq Ft/Case)	15.40 ft <sup>2</sup> /case (1.43 m <sup>2</sup> /case)
<i>Shelf Area</i> <sup>3</sup> (Sq Ft/Case)	13.19 ft <sup>2</sup> /case (1.23 m <sup>2</sup> /case)

<sup>1</sup> AHRI Refrigerated Volume less shelving and other unusable space: Refrigerated Volume/Unit of Length, ft<sup>3</sup>/ft [m<sup>3</sup>/m]

<sup>2</sup> Computed using AHRI 1200 standard methodology: Total Display Area, ft<sup>2</sup> [m<sup>2</sup>]/Unit of Length, ft [m]

<sup>3</sup> Shelf surface area is composed of bottom deck plus standard shelf complement, as shown in the Hussmann *Product Reference Guide*. The standard shelf complement for this model is NONE.

### ESTIMATED SHIPPING WEIGHT <sup>4</sup>

**PWEE End Case**

300 (136)

<sup>4</sup> Actual weights will vary according to optional kits included.

## Fan Wiring Offtime Defrost

### 1 Fan

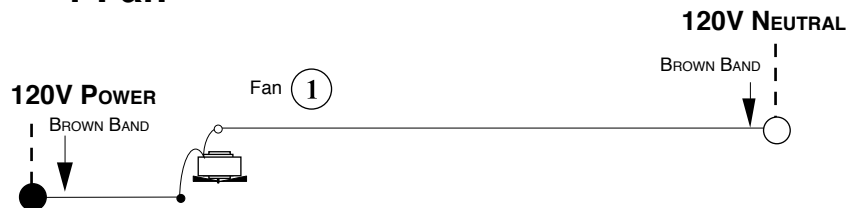

### WARNING

All components must have mechanical ground, and the merchandiser must be grounded.

CIRCLED NUMBERS = PARTS LIST ITEM NUMBERS

● = 120V POWER    ○ = 120V NEUTRAL