

# HUSSMANN®

## microSC™

# MNGSC-A

## Medium Temperature Self Contained Island Merchandisers

### WARNINGS:

If the information in these instructions are not followed exactly, a fire or explosion may result, causing property damage, personal injury or death.

Installation and service must be performed by a qualified installer or service agency.

**READ THE ENTIRE MANUAL BEFORE  
INSTALLING OR USING THIS EQUIPMENT.**

The unit uses R-290 gas as the refrigerant. R-290 is flammable and heavier than air. It collects first in low areas but can be circulated by the fans. If propane gas is present or even suspected, do not allow untrained personnel to attempt to find the cause. The propane gas used in the unit has no odor. The lack of smell does not indicate a lack of escaped gas. If a leak is detected, immediately evacuate all persons from the store, and contact the local fire department to advise them that a propane leak has occurred. Do not let any persons back into the store until the qualified service technician has arrived and that technician advises that it is safe to return to the store. No open flames, cigarettes or other possible sources of ignition should be used inside or in the vicinity of the units.

**FAILURE TO ABIDE BY THIS WARNING COULD  
RESULT IN AN EXPLOSION, DEATH, INJURY AND  
PROPERTY DAMAGE.**

**IMPORTANT**

Keep in store for future reference!



## Installation & Operation Manual

**P/N 3113125\_C**

June 2022

**Spanish 3113126**



## BEFORE YOU BEGIN

Read these instructions completely and carefully.

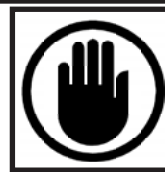

### PERSONAL PROTECTION EQUIPMENT (PPE)

Personal Protection Equipment (PPE) is required whenever installing or servicing this equipment. Always wear safety glasses, gloves, protective boots or shoes, long pants, and a long-sleeve shirt as required when installing or servicing this equipment.

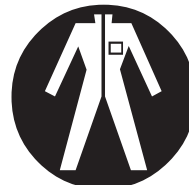
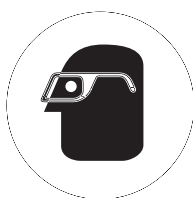

1. If the information in these instructions are not followed exactly, a fire or explosion may result, causing property damage, personal injury or death.
2. Installation and service must be performed by a qualified installer or service agency.
3. This unit is designed only for use with R-290 gas as the designated refrigerant.

#### **THE REFRIGERANT LOOP IS SEALED. ONLY A QUALIFIED TECHNICIAN SHOULD ATTEMPT TO SERVICE!**

- Propane is flammable and heavier than air.
- It collects first in the low areas but can be circulated by the fans.
- If R-290 is present or even suspected, do not allow untrained personnel to attempt to find the cause.
- The propane gas used in the unit has no odor.
- The lack of smell does not indicate a lack of escaped gas.
- If a leak is detected, immediately evacuate all persons from the store, and contact the local fire department to advise them that a propane leak has occurred.
- Do not let any persons back into the store until the qualified service technician has arrived and that technician advises that it is safe to return to the store.
- A hand-held propane leak detector (“sniffer”) shall be used before any repair and/or maintenance.
- No open flames, cigarettes or other possible sources of ignition should be used inside the building where the units are located until the qualified service technician and/or local fire department determines that all propane has been cleared from the area and from the refrigeration systems.
- Component parts are designed for propane and non-incendive and non-sparking. Component parts shall only be replaced with identical repair parts.

**FAILURE TO ABIDE BY THIS WARNING COULD RESULT IN AN EXPLOSION, DEATH, INJURY AND PROPERTY DAMAGE.**

## TABLE OF CONTENTS

<p><b>ANSI Z535.5 DEFINITIONS</b> ..... vi</p> <p><b>INSTALLATION</b></p> <p>UL Listing ..... 1-1</p> <p>Federal / State Regulation ..... 1-1</p> <p>Hussmann Product Control ..... 1-1</p> <p>Shipping Damage ..... 1-1</p> <p>Location ..... 1-1</p> <p>Self Contained Location ..... 1-2</p> <p>Model Description ..... 1-2</p> <p>Unloading ..... 1-3</p> <p>Shipping Skid ..... 1-3</p> <p>Merchandiser Leveling ..... 1-4</p> <p>Serial Plate Location ..... 1-4</p> <p>Refrigeration Unit Access ..... 1-5</p> <p>Sealing Merchandiser to Floor ..... 1-5</p> <p>Self-Contained Refrigeration Equipment Start Up Check List ..... 1-6</p> <p><b>ELECTRICAL / REFRIGERATION</b></p> <p>Merchandiser Electrical Data ..... 2-1</p> <p>Field Wiring ..... 2-1</p> <p>Electrical Connections ..... 2-1</p> <p>Electrical Outlet ..... 2-1</p> <p>Condensate Pan Heater ..... 2-1</p> <p>Refrigeration (Self Contained Models) .. 2-1</p> <p>Refrigeration System Layout..... 2-2</p> <p>Replacing Refrigeration System   Components ..... 2-6</p> <p>Steps to Recover Refrigerant ..... 2-6</p> <p>Charging ..... 2-6</p> <p>Evaporation Pan(s) ..... 2-8</p>	<p><b>START UP / OPERATION</b></p> <p>Controller Operation ..... 3-1</p> <p>Connections ..... 3-2</p> <p>LED ..... 3-3</p> <p>KDEPLUS Buttons ..... 3-4</p> <p>Setpoint: Setting and Edit Lock ..... 3-5</p> <p>Display Probes Value..... 3-5</p> <p>Key-Activated Functions..... 3-5</p> <p>Typical Sensor Locations..... 3-6</p> <p>Controls and Adjustments ..... 3-9</p> <p>Load Limits ..... 3-10</p> <p>Stocking ..... 3-10</p> <p>Installing FDA/NSF Required   Thermometer ..... 3-11</p> <p><b>MAINTENANCE</b></p> <p>Care and Cleaning ..... 4-1</p> <p>Removing Scratches from Bumper ..... 4-2</p> <p>Cleaning Under Fan Plenum ..... 4-2</p> <p>Cleaning Discharge Air Honeycomb .... 4-2</p> <p>Cleaning Stainless Steel Surfaces ..... 4-3</p> <p>Cleaning Condenser Air Filter ..... 4-3</p> <p>Reversible Condenser Fan Feature ..... 4-4</p> <p>Cleaning Evaporation Pan ..... 4-5</p> <p>Self-Contained Refrigeration Equipment   Maintenance Check List ..... 4-6</p> <p><b>SERVICE</b></p> <p>Replacing Fan Motors and Blades ..... 5-1</p> <p>Troubleshooting Guide ..... 5-2</p> <p><b>APPENDIX A</b></p> <p>Joining instructions ..... 5-4</p>
--	---

REVISION HISTORY

REVISION C — Added 4 ft and 6 ft models

REVISION B — FEBRUARY 2020 Added Warning: Picture - Page 1-4; Page 2-1, 2-2, 2-3

ORIGINAL ISSUE — JANUARY 2020

\*\*\*\*\*

ANSI Z535.5 DEFINITIONS

 • **DANGER** – Indicate[s] a hazardous situation which, if not avoided, will result in death or serious injury.

 • **WARNING** – Indicate[s] a hazardous situation which, if not avoided, could result in death or serious injury.

 • **CAUTION** – Indicate[s] a hazardous situation which, if not avoided, could result in minor or moderate injury.

• **NOTICE** – *Not related to personal injury* – Indicates[s] situations, which if not avoided, could result in damage to equipment.

ATTENTION

Merchandiser must operate for 24 hours before loading product!

Regularly check merchandiser temperatures.

Do not break the cold chain. Keep products in cooler before loading into merchandiser.

These merchandisers are designed for only pre-chilled products.



**IMPORTANT**  
**KEEP IN STORE FOR FUTURE REFERENCE**  
*Quality that sets industry standards!*

12999 St. Charles Rock Road • Bridgeton, MO 63044-2483

U.S. & Canada 1-800-922-1919 • Mexico 1-800-890-2900

[www.hussmann.com](http://www.hussmann.com)

© 2022 Hussmann Corporation

## INSTALLATION

### UL LISTING

These merchandisers are manufactured to meet ANSI/ UL 471 standard requirements for safety. Proper installation is required to maintain the listing.

### FEDERAL / STATE REGULATION

These merchandisers at the time they are manufactured, meet all federal and state/provincial regulations. Proper installation is required to ensure these standards are maintained. Near the serial plate, each merchandiser carries a label identifying the environment for which the merchandiser was designed for use. Please note: 8 ft cases are certified to operate under Type 1 Conditions. 6 ft and 4 ft case can operate at Type 2 Conditions as described below.

**ANSI/NSF-7 Type I – Display Refrigerator / Freezer  
Intended for 75°F (24°C) / 55% RH Ambient Application**

**ANSI/NSF-7 Type II – Display  
Refrigerator / Freezer Intended for 80°F /  
55%RH Ambient Application**

**ANSI/NSF-7 – Display Refrigerator  
Intended for Bulk Produce**

### HUSSMANN PRODUCT CONTROL

The serial number and shipping date of all equipment is recorded in Hussmann's files for warranty and replacement part purposes. All correspondence pertaining to warranty or parts ordering must include the serial number of each piece of equipment involved. This is to ensure the customer is provided with the correct parts.

### SHIPPING DAMAGE

All equipment should be thoroughly examined

for shipping damage before and during unloading. This equipment has been carefully inspected at our factory. Any claim for loss or damage must be made to the carrier. The carrier will provide any necessary inspection reports and/or claim forms.

### Apparent Loss or Damage

If there is an obvious loss or damage, it must be noted on the freight bill or express receipt and signed by the carrier's agent; otherwise, carrier may refuse claim. Do not under any circumstances connect a damaged cabinet to the electric circuit. Otherwise, there is the risk of electric shock or refrigerant leakage!

### Concealed Loss or Damage

When loss or damage is not apparent until after equipment is uncrated, retain all packing materials and submit a written response to the carrier for inspection within 15 days.

### LOCATION

These merchandisers are designed for displaying products in air conditioned stores where temperature is maintained at or below the ANSI / NSF-7 specified level and relative humidity is maintained at or below 55%. Placing refrigerated merchandisers in direct sunlight, near hot tables or near other heat sources could impair their efficiency. Like other merchandisers, these merchandisers are sensitive to air disturbances. Air currents passing around merchandisers will seriously impair their operation. Do NOT allow air conditioning, electric fans, open doors or windows, etc. to create air currents around the merchandiser.

**Recommended operating ambient  
temperature is between  
65°F (18°C) to 75°F (24°C).  
Maximum relative humidity is 55%.**

SELF CONTAINED (LOCATION)

Product should always be maintained at proper temperature. This means that from the time the product is received, through storage, preparation and display, the temperature of the product must be controlled to maximize the life of the product.

BE SURE TO POSITION SELF CONTAINED MERCHANDISERS PROPERLY.

SELF CONTAINED models have vented base panels to allow air circulation through the condensing unit.

Allow for a minimum 10-inch clearance from walls, merchandisers, and any other large objects near the merchandiser’s vented base panels (for self contained models). Blocking or restricting air flow will adversely affect performance and may damage the refrigeration system.

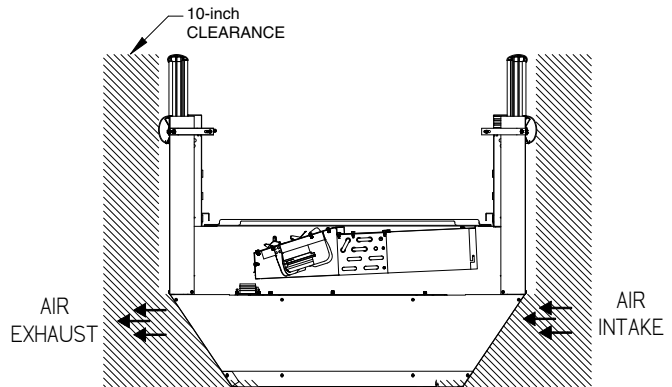

This warning does not mean that Hussmann products will cause cancer or reproductive harm, or is in violation of any product-safety standards or requirements. As clarified by the California State government, Proposition 65 can be considered more of a ‘right to know’ law than a pure product safety law. When used as designed, Hussmann believes that our products are not harmful. We provide the Proposition 65 warning to stay in compliance with California State law. It is your responsibility to provide accurate Proposition 65 warning labels to your customers when necessary. For more information on Proposition 65, please visit the California State government website.



MODEL DESCRIPTION

The MNGSC-A models are island, spot display merchandisers. 8 ft cases have two self contained units with one dual circuited evaporator. 4 and 6 ft cases have one condensing unit with standard evaporator-

MNGSC-A models are designed for medium temperature operation. These models have upper glass on all four sides of the merchandiser.

## UNLOADING

### Unloading from Trailer:

Lever Bar (also known as a Mule, Johnson Bar, J-bar, Lever Dolly, or Pry Lever)

Move the merchandiser as close as possible to its permanent location and remove all packaging. Check for damage. Remove all separately packed accessories. Improper handling may cause damage to the merchandiser when unloading.

To avoid damage:

1. Do not drag the merchandiser out of the trailer. Use a Johnson bar (mule). Use a forklift or dolly to remove the merchandiser from the trailer.
2. Use caution when moving case to setup location. Use care to not damage refrigeration system. Confirm there are no refrigerant leaks during startup of the case(s).

## SHIPPING SKID

Each merchandiser is shipped on a skid to protect the merchandiser's base, and to make positioning the case easier.

Remove the top of the crate and detach walls from each other (if provided). Lift crate from the skid. Unscrew the case from the skid. The fixture can now be lifted off the crate skid. **Lift only at base of skid!** Remove any braces and/or skids attached (blanket wrapped merchandiser may have skids).

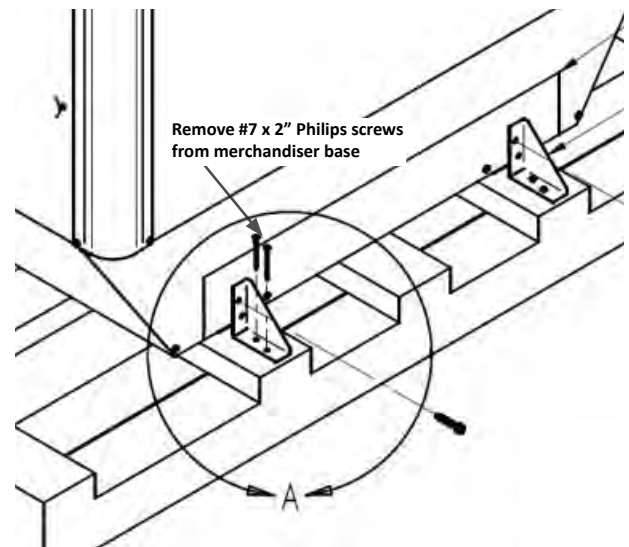

**DO NOT LAY MERCHANDISER OVER ON THE FLOOR TO REMOVE SKID.**

Once the skid is removed, the merchandiser must be lifted —NOT PUSHED— to reposition. To remove the skid, remove screws attaching skid to the merchandiser.

### **⚠ WARNING**

**Do NOT stand or walk on top of merchandiser. Do not store items or flammable materials atop the unit.**

### **⚠ WARNING**

**Do NOT remove shipping skid until the merchandiser is positioned for installation.**

## MERCHANDISER LEVELING

Check floor where cases are to be set to see if it is a level area. Determine the highest part of the floor.

Merchandise(s) must be installed level to ensure proper operation of the refrigeration system and to ensure proper drainage of defrost water.

**BE SURE TO POSITION MERCHANDISERS PROPERLY.** Use a 3 ft carpenter's level, and level the case by all four corners. Place the level on the hand rails as shown in the illustration below.

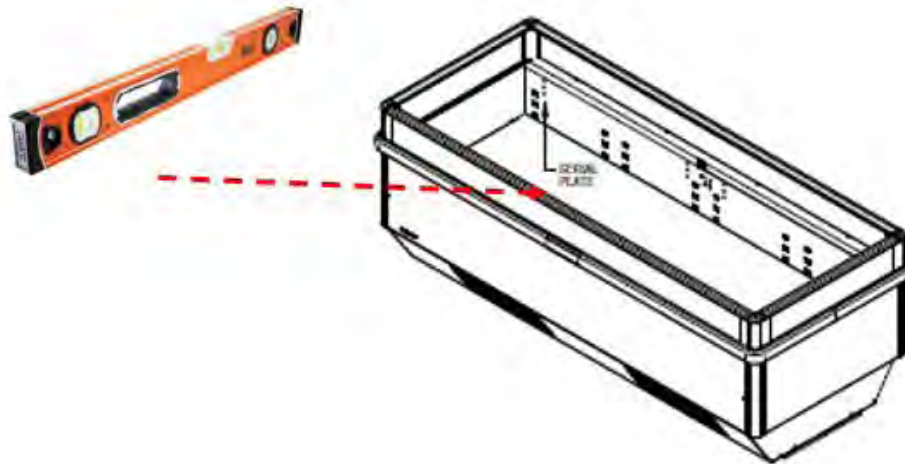

---

## SERIAL PLATE LOCATION

The serial plate is located on the inside of the merchandiser's display area.

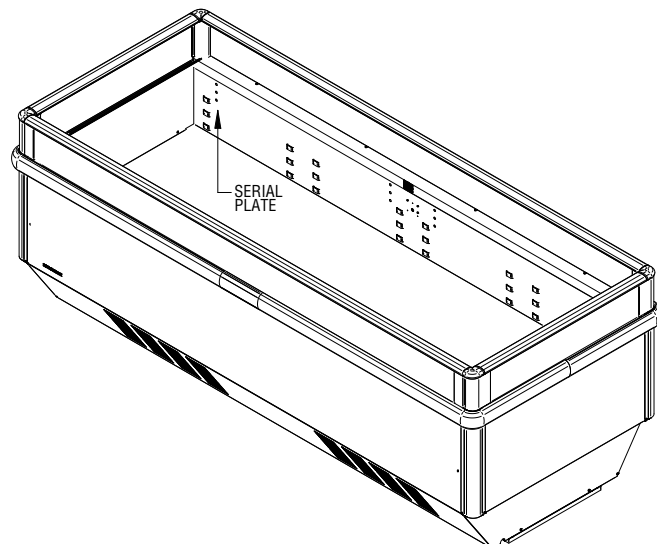

## REFRIGERATION UNIT ACCESS

The lower front panel may be removed by lifting the panel straight upward and over the tabs on which it is hanging. For self contained cases, two screws will have to be removed from either end of the panel. Make sure all electrical wiring is secured, and that there is no damage to the unit from shipment or placement.

Confirm there are no refrigerant leaks during startup of the case(s). The panel is installed by reversing the above procedure. Ensure merchandiser base is properly installed on case to prevent air circulation problems.

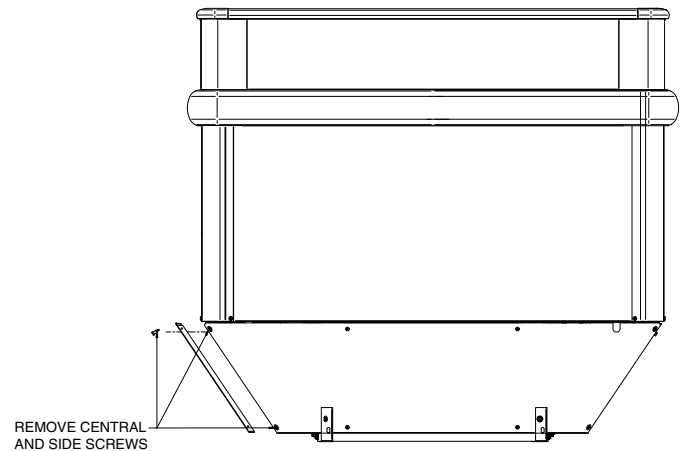

## SEALING MERCHANDISER TO FLOOR

If required by local sanitary codes, or if the customer desires, merchandisers may be sealed to the floor. Make sure lower front and rear panels are still able to be removed to service the condensing unit when sealing around the case.

**NOTE:** Do not allow trim to cover any intake or discharge grilles located in the lower front panel. When the merchandiser is equipped with levelers, sealing to the floor may not be required. Merchandiser may be relocated to another location so that floor can be cleaned.

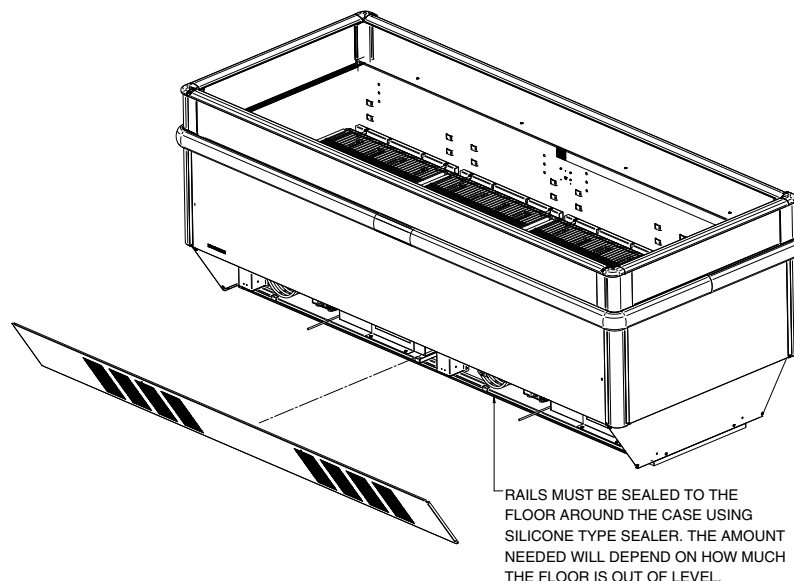

## Hussmann Self-Contained Refrigeration Equipment Start Up Check List

\*\*\*Please note that failure to follow this start-up document may void your factory warranty\*\*\*

Step	Startup Activity	Check
1	Locate, read and keep install/operation manual in a safe place for future reference.	<input type="checkbox"/>
2	Examine unit. Confirm there is NO damage or concealed damage.	<input type="checkbox"/>
3	Level the unit, side to side and front to rear.	<input type="checkbox"/>
4	Remove all shipping brackets/compressor straps/bolts etc.	<input type="checkbox"/>
5	Unit must be run on a dedicated electrical circuit. Do not use adapters.	<input type="checkbox"/>
6	Ensure that the proper electrical requirements for the equipment are supplied.	<input type="checkbox"/>
7	Verify all electrical wiring is secured and clear of any sharp edges or hot lines. Connect plug to the outlet.	<input type="checkbox"/>
8	Some water should be placed in the drain to close the siphon and prevent formation of ice.	<input type="checkbox"/>
9	Verify the condensate drain line is properly trapped and pitched.	<input type="checkbox"/>
10	Verify all required clearances on the sides and back of unit.	<input type="checkbox"/>
11	Verify there are no air disturbances external to the unit. Heat and air registers, fans, and doors etc.	<input type="checkbox"/>
<b>Advise owner/operator that merchandiser must operate at temperature for 24 hrs prior to loading with product.</b>		

## LEGAL DISCLAIMER:

Hussmann shall not be liable for any repair or replacements made without the written consent of Hussmann, or when the product is installed or operated in a manner contrary to the printed instructions covering installation and service which accompanied such product.

## ELECTRICAL / REFRIGERATION

### MERCHANDISER ELECTRICAL DATA

Refer to the technical data sheets and merchandiser serial plate for electrical information.

### FIELD WIRING

Field wiring must be sized for component amperes stamped on the serial plate. Actual ampere draw may be less than specified.

**ALWAYS CHECK THE SERIAL PLATE FOR COMPONENT AMPERES**

### ELECTRICAL CONNECTIONS

All wiring must be in compliance with NEC and local codes.

### ELECTRICAL OUTLET:

Before the merchandiser is connected to any wall circuit, use a voltmeter to check that the outlet is at 100% of the rated voltage. The wall circuit must be dedicated for the merchandiser. Failure to do so voids the warranty. Do not use an extension cord. Never plug in more than one merchandiser per electrical circuit.

- Always use a dedicated circuit with the amperage stated on the unit.
- Plug into an outlet designed for the plug.
- Do not overload the circuit
- Do not use long or thin extension cords. Never use adapters.
- If in doubt, call an electrician.



NEMA 5-15P  
Plug

Self-contained models have factory-installed power cords attached at the electrical box. If the power cord is damaged, it must be replaced by personnel qualified for this task to prevent hazardous situations.



## WARNING

**Merchandiser must be grounded.  
Do not remove the power supply cord ground.**



## CAUTION

**Risk of Electric Shock. If cord or plug becomes damaged, replace only with a cord and plug of the same type.**

### CONDENSATE PAN HEATER (Optional)

A condensate pan heater is available as an option. This kit is optional only for 8 ft case. As a standard offering, there is no heater installed in the condensate pan.

### REFRIGERATION (Self Contained Models)

8 ft case have two self contained units with one dual circuited evaporator. 4 and 6 ft cases have one condensing unit with standard evaporator. The correct type of refrigerant will be stamped on each merchandiser's serial plate. The merchandiser refrigeration piping is leak tested.

## REFRIGERATION SYSTEM LAYOUT

Product must be pre-chilled to 41°F (5 °C) or less prior to being placed in merchandiser. The evaporator is dual circuited. Circuit 1 is the bottom section, and Circuit 2 is the top section. In Figure B, LH circuit is shown. The flow is described as the following: Cap tube is feeding the bottom section of the coil.

Once the refrigerant passes through the evaporator, refrigerant goes out to the suction line to the compressor. The discharge line runs through the evaporation pan to increase the water temperature located in the top level of the evaporation pan. At the same time, refrigerant temperature drops, increasing system capacity.

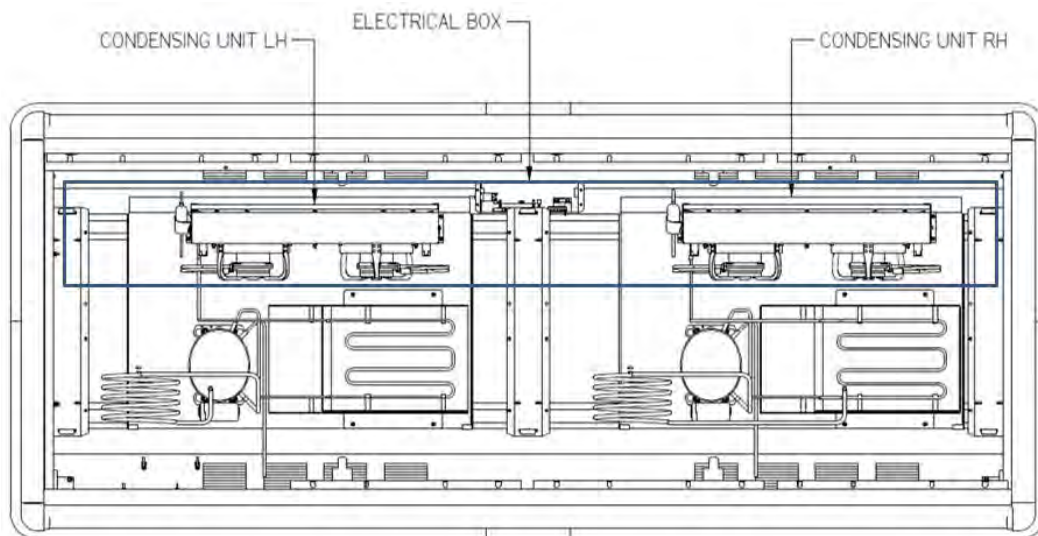

**Figure A. Machine Compartment Layout (8-ft case shown)**

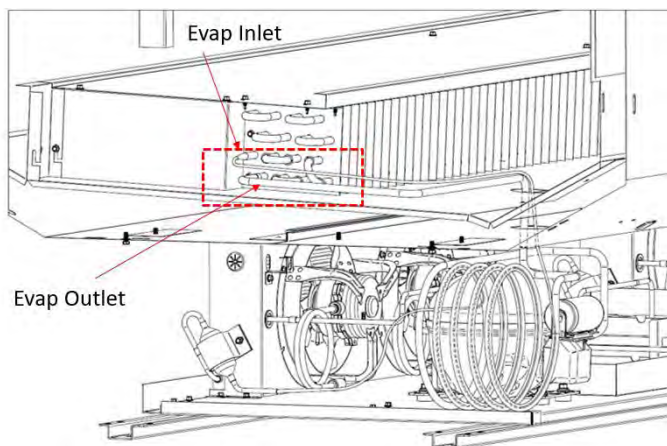

**Figure B. Refrigeration Circuit #1 (left side) (8-ft case shown)**

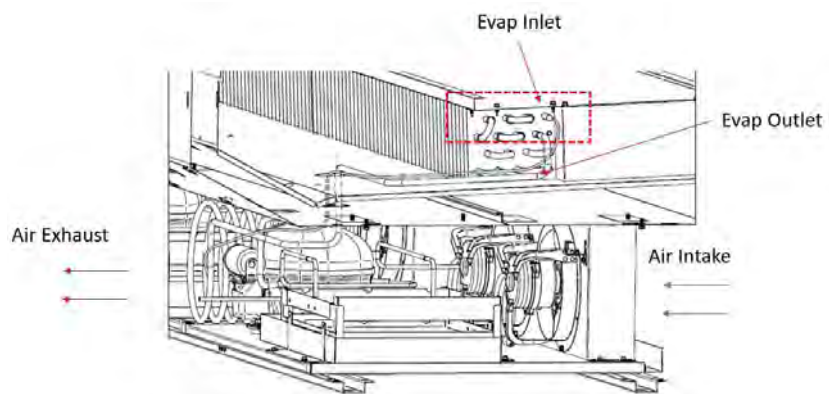

**Figure C. Refrigeration Circuit #2 (right side)**

Refrigerant flow for (right side Circuit #2): Cap tube is feeding the top section of the coil. Once the refrigerant passes through the evaporator, refrigerant goes out to the suction line, then to the compressor.

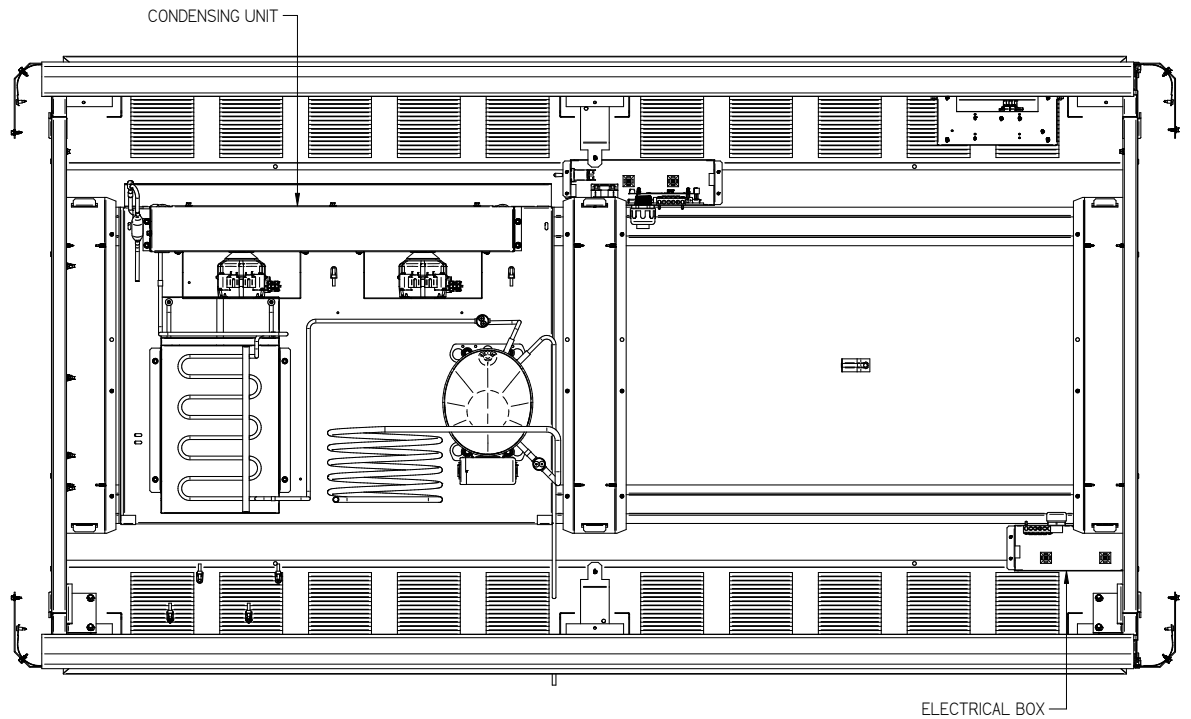

Figure D. Machine Compartment Layout (6-ft case shown)

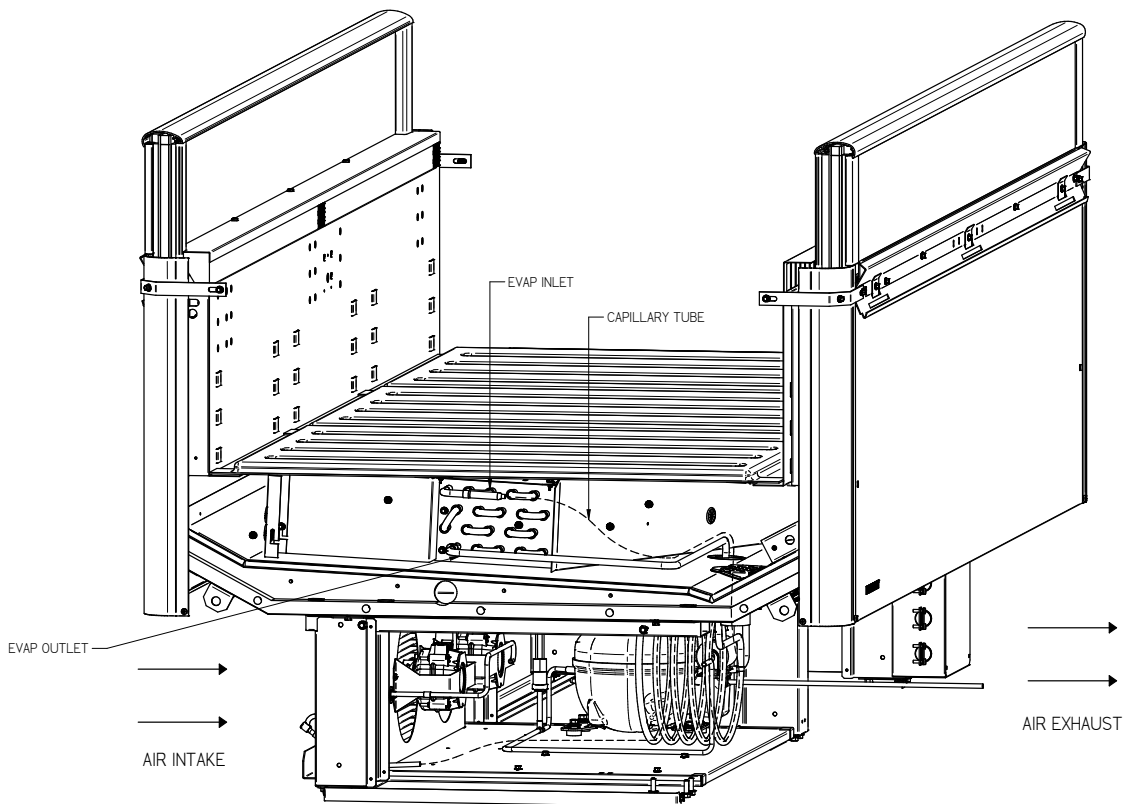

Figure E. Refrigeration Circuit (6-ft case shown)

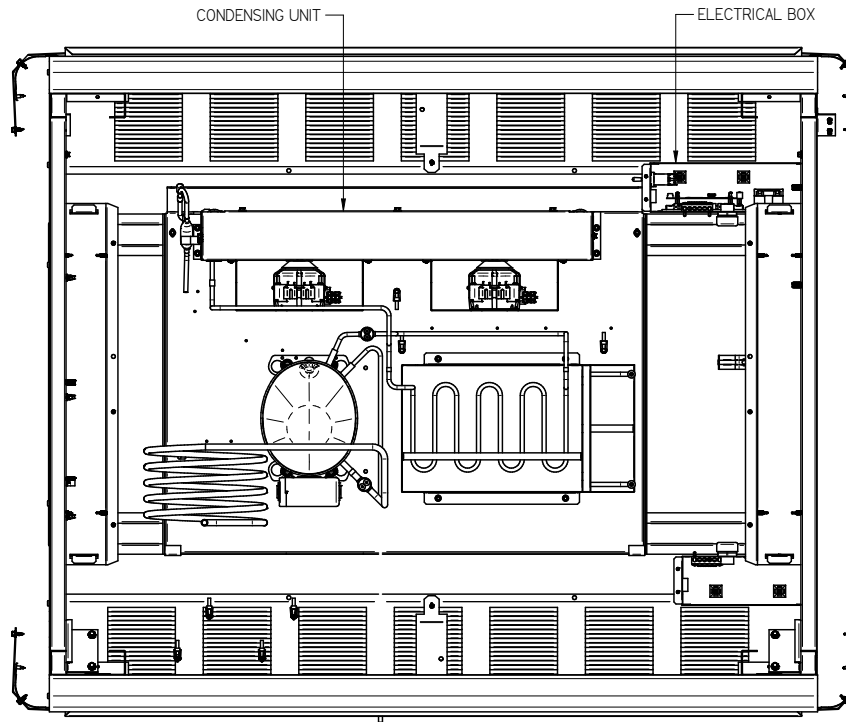

Figure F. Machine Compartment Layout (4-ft case shown)

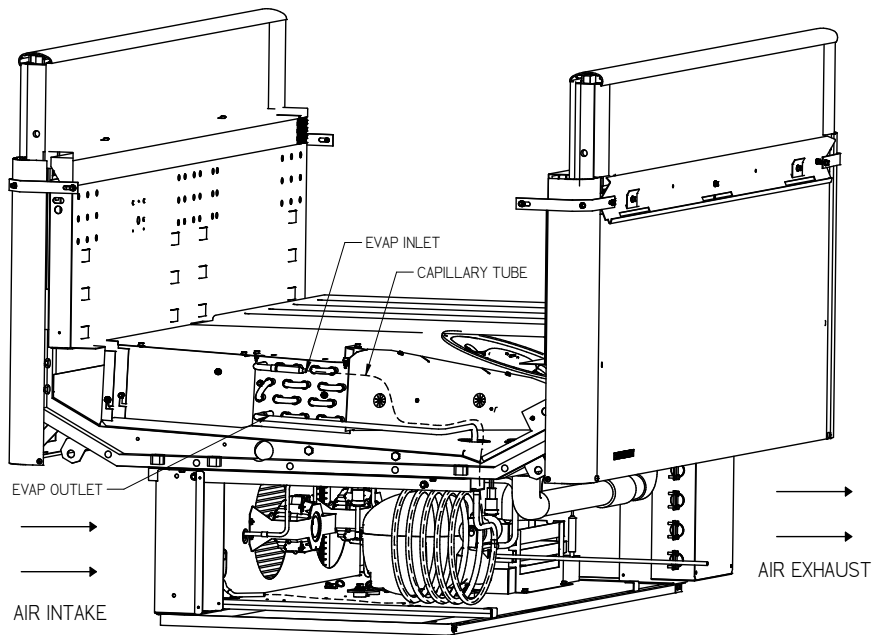

Figure G. Refrigeration Circuit (4-ft case shown)

## Before Beginning Any Service or Repair:

Use a hand-held propane leak detector (“sniffer”) to ensure no propane is present in the immediate area, the inside of the display case and the inside of the refrigeration system. R-290 is an odorless refrigerant. Keep the area clear of all customers and non-essential or unauthorized personnel.

Verify that all repair parts are identical models to the ones they are replacing. Do not substitute parts such as motors, switches, relays, heaters, compressors, power supplies or solenoids. Failure to do so can result in an explosion, death, injury and property damage. Parts used on hydrocarbon cases must meet specific UL certification for non-incendive or non-sparking components. Use only Hussmann approved parts approved through the Hussmann Performance Parts Website. <https://parts.hussmann.com/>

## **WARNING**

Only Hussmann or factory trained technicians should service or repair this R-290 (propane) equipment.

Failure to follow instructions can result in an explosion, death, injury and property damage.

Brazing must not begin before all propane has been cleared from the immediate area — the inside of the display case and the inside of the refrigeration system.

## **WARNING**

**Refrigeration lines are under pressure. Refrigerant must be recovered before attempting any connection or repair.**



...ATTENTION  
INSTALLER

**It is the installing contractor's responsibility to consult local agencies for local code requirements.**

If a leak is detected, follow store safety procedures. It is the store's responsibility to have a written safety procedure in place. The safety procedure must comply with all applicable codes such as local fire department's codes.

At minimum, the following actions are required:

- Immediately evacuate all persons from the store, and contact the local fire department to advise them that a propane leak has occurred.
- Call Hussmann and/or a qualified service agent and inform them that a propane sensor has detected the presence of propane.
- Do not let any persons back into the store until the qualified service technician has arrived and that technician advises that it is safe to return to the store.

• The propane gas used in the unit has no odor. The lack of smell does not indicate a lack of escaped gas.

• A hand-held propane leak detector ("sniffer") should be used before any repair and/or maintenance is attempted. All repair parts must be identical models to the ones they are replacing.

• No open flames, cigarettes or other possible sources of ignition should be used inside the building where the units are located until the qualified service technician and/or local fire department determines that all propane has been cleared from the area and from the refrigeration systems.

## REPLACING REFRIGERATION SYSTEM COMPONENTS



# DANGER

**Only Hussmann service technicians or technicians qualified to handle R-290 (propane) refrigerant should service or repair this R-290 (propane) equipment. Failure to follow instructions can result in an explosion, death, injury and property damage.**



**refrigeration  
line tapping  
valve**

## STEPS TO RECOVER REFRIGERANT

1. Make sure you are in a well ventilated area before making any service or repair to the refrigeration system.
2. Disconnect all power sources from the system. Some systems may have more than one plug or power supply.
3. Tap system with line tap valves, attaching gauges to the high and low sides of the system.
4. Connect hose to an evacuated recovery tank. Open refrigeration gauges and recovery tank.
5. With the suction valve in vacuum, the refrigerant will be recovered into the recovery tank.
6. Once recovered, close the tank valve and remove the gauge from the tank and connect nitrogen tank to the system to purge it with nitrogen.

7. Pull vacuum to a minimum of 200 microns or lower.



Use dedicated hoses to service R-290 (propane) refrigeration systems. Hoses or lines should be as short as possible to minimize the amount of refrigerant contained in them.

Ensure that the refrigeration system is properly grounded prior to charging the system with refrigerant, to avoid the potential for static build-up.

### CHARGING

A calibrated scale with +/-2 gram accuracy must be used to charge the system. The charge amount is shown on the serial plate. Only R-290 grade refrigerant can be used. Standard propane does not meet the purity/moisture content of R-290, and therefore cannot be used to charge cases.

No gas charge adjustments are allowed. When connecting hoses between the refrigeration system, manifold gauges, and refrigerant cylinder, ensure that the connections are secure and there are no potential sources of ignition nearby. Ensure that contamination of different refrigerants does not occur when using charging equipment.

**⚠ WARNING**  
**Component parts shall be replaced with like components, and servicing shall be done by factory authorized service personnel only, so as to minimize the risk of possible ignition due to incorrect parts or improper service.**

Extreme care must be taken not to overfill the refrigeration system. After charging, carefully disconnect the hoses, attempting to minimize the quantity of refrigerant released. Further leak check the service ports, hoses, refrigerant tanks. The service ports shall be checked for leaks using a hydrocarbon leak detector with a sensitivity of 3 grams/year (0.106 Oz/year) leak rate.

Thoroughly leak check the service ports. If no leak is present, use a pinch-off tool to close the ends of the service tubes before brazing them shut. Remove all service ports. If a Schrader valve is used on the compressor service tube, it must be removed and the previous steps followed in order to braze the service tube shut.

**⚠ WARNING**  
**— LOCK OUT / TAG OUT —**  
*To avoid serious injury or death from electrical shock, always disconnect the electrical power at the main disconnect when servicing or replacing any electrical component. This includes, but is not limited to, such items as doors, lights, fans, heaters, and thermostats.*



EVAPORATION PAN(S)

Make sure the water level is similar in both pans (8 ft case). During defrost cycle or off-time when the compressor reaches setpoint, the water from the evaporator goes to each evaporation pan.

**NOTE:** All lower base panels must be in place when the refrigerator is operating. If not, airflow from the condenser will be directed over the evaporator pan and defrost water in the pan may overflow.

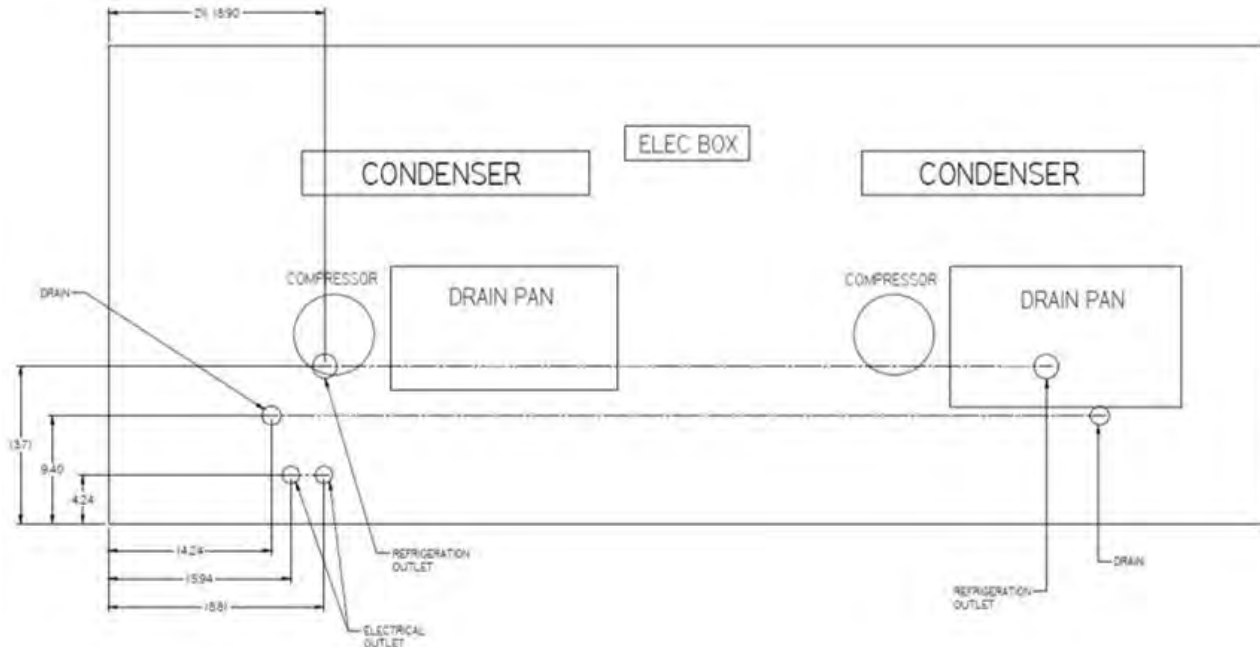

Figure A. (Top View) Drain Pan Locations (8-ft Case)

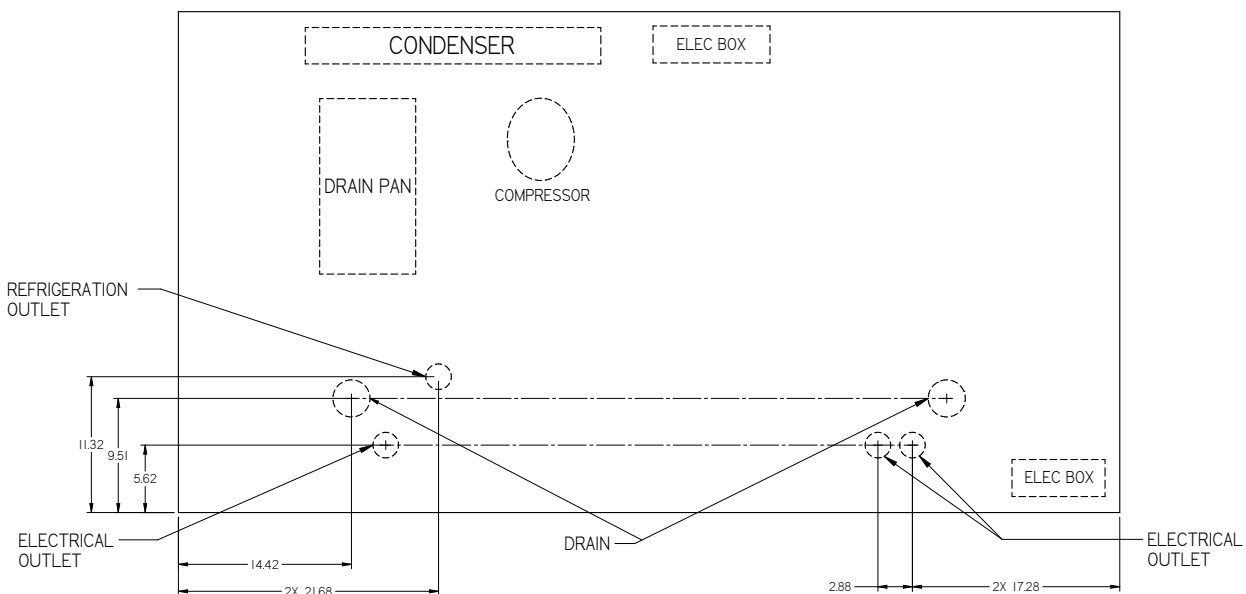
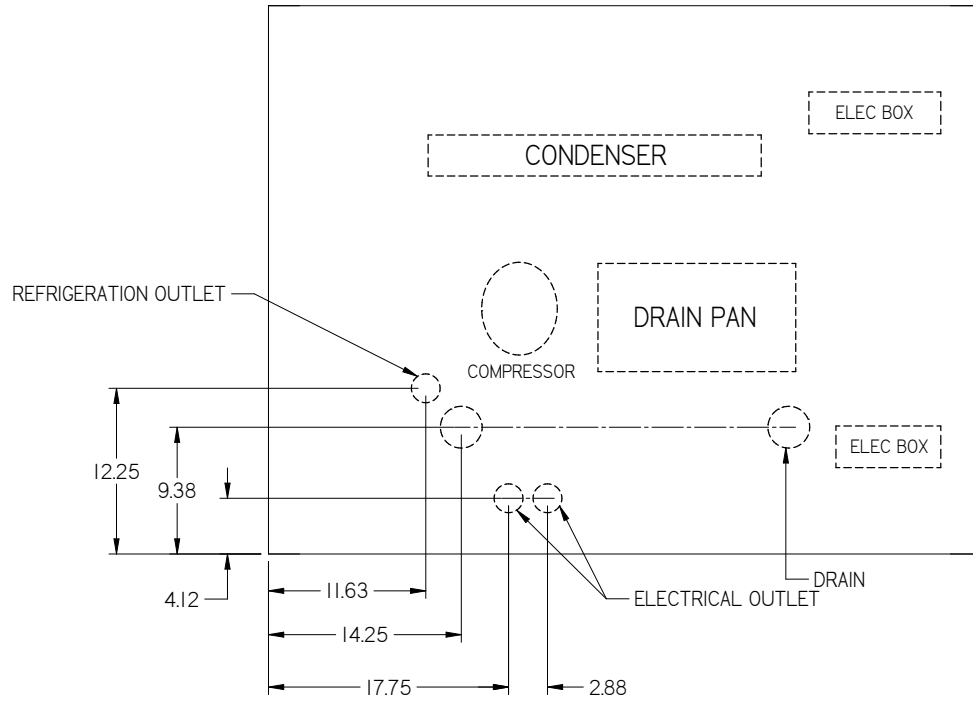

Figure B. (Top View) Drain Pan Locations (6-ft Case)



**Figure C. (Top View) Drain Pan Locations (4-ft Case)**

Drain Piping Assembly Views

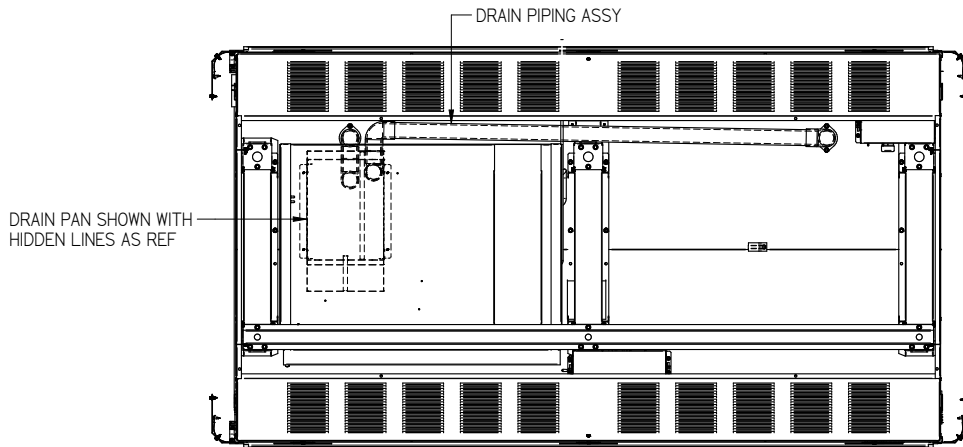
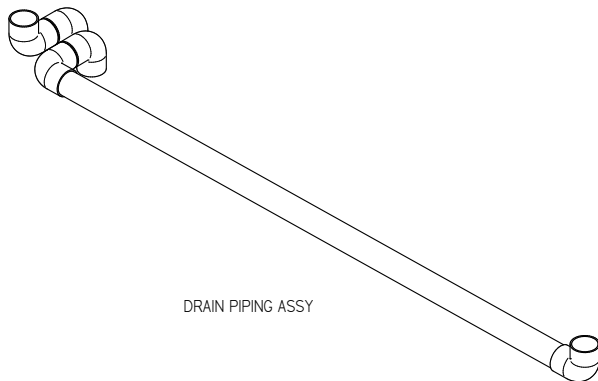

Figure D. (Top View) Drain Piping Locations (6-ft Case)



DRAIN PIPING ASSY

**⚠ WARNING**

**MERCHANDISER LEVELING**

Be sure to position merchandisers properly. Level the merchandisers by all four corners. Merchandiser(s) must be installed level to ensure proper operation of the refrigeration system, and to ensure proper drainage of defrost water.

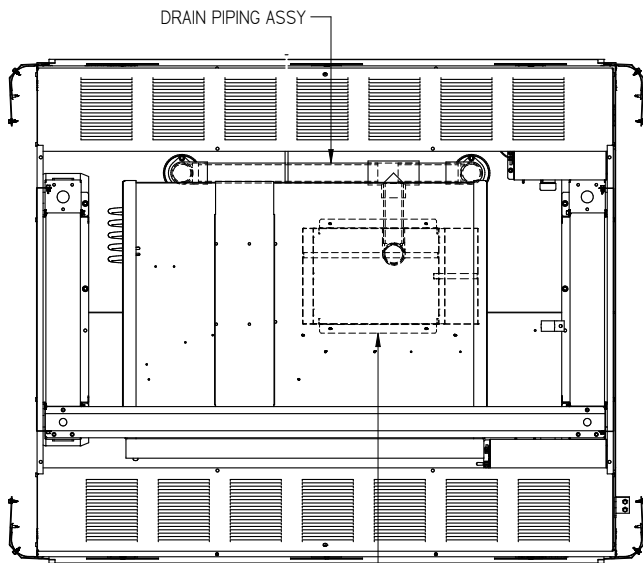

DRAIN PIPING ASSY

DRAIN PAN SHOWN WITH HIDDEN LINES AS REF

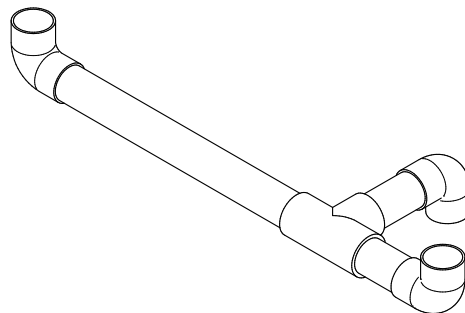

DRAIN PIPING ASSY

Figure E. (Top View) Drain Piping Locations (4-ft Case)

## START UP / OPERATION

### CONTROLLER OPERATION

The electronic controller is located in the cassette compartment. The controller comes factory set, and is ready for use. The front grille must be removed in order to access this control. When removing the grille for this operation or for condenser cleaning, care must be taken not to damage the display interface cable. It may be unplugged during this task.

1. Plug the merchandiser plug into its receptacle.
  - a. The controller display will illuminate.
  - b. The interior light will illuminate.
2. After the control preprogrammed time delay of up to 6 minutes, the compressor and evaporator fan(s) will start if the control is calling for cooling.
3. The control will cycle the compressor but may also cycle evaporator fan(s) on and off determined by the setpoint and differential temperatures.
  - a. The setpoint is the adjustable preprogrammed temperature.
  - b. The differential is the non-adjustable pre-programmed temperature.
  - c. The control is designed to read and display a cabinet temperature not a product temperature.

This cabinet temperature may reflect the refrigeration cycle of the setpoint and it's differential. The most accurate temperature on a cabinets operation is to verify the product temperature.

#### Main Features:

- Panel-mounted
- Energy saving algorithms and optimised defrost control
- 8 preloaded applications
- Defrost at single / double evaporator
- Frame Heater
- Local network auto-configuration
- Direct load connection (up to 2 HP)
- Supply voltage control LVD
- Presence of an open collector output

DISPLAY CONTROL



# CONNECTIONS

## TERMINALS

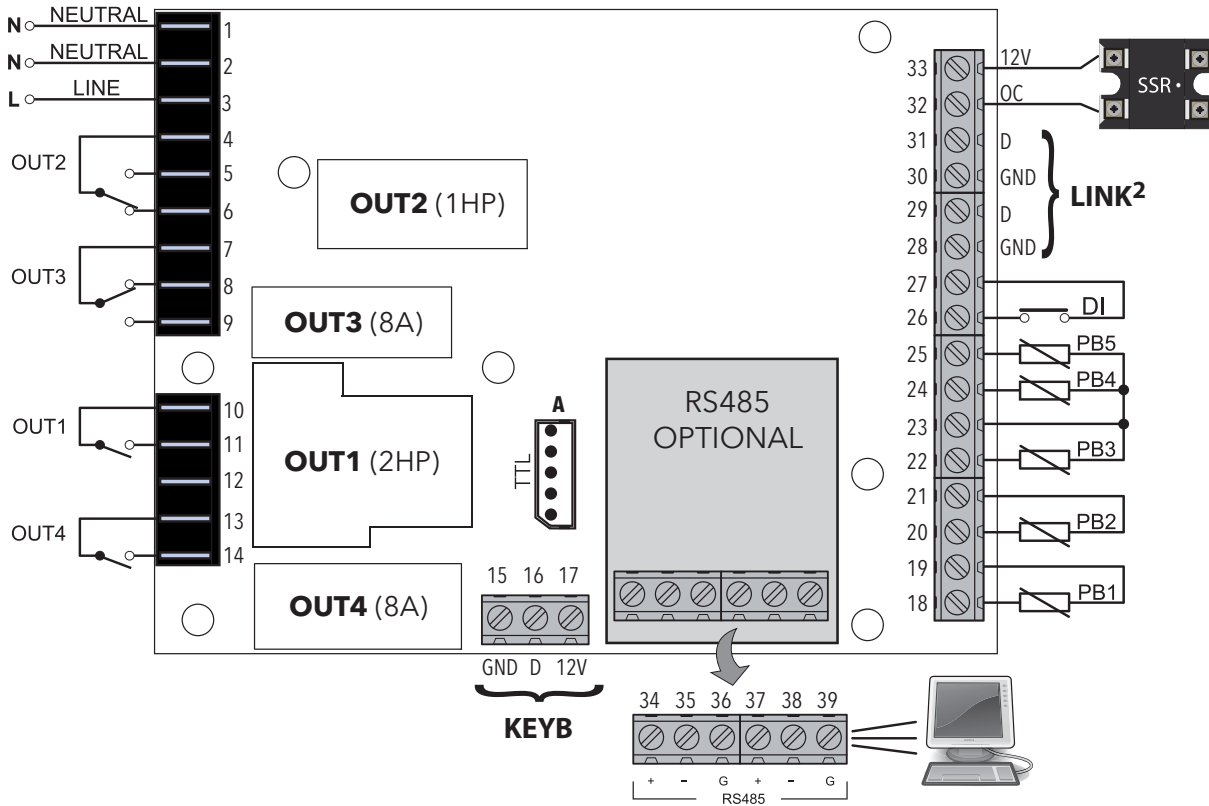

\* **N.B.:** analogue inputs PB1...PB5 can also be configured as Digital Inputs DI.

TERMINALS		
<b>1-2</b>	NEUTRAL. These are power supply terminals.	<b>15-16-17</b> Connection to KDEPlus or KDWPlus external keyboard or ECPlus echo module.
<b>3</b>	LINE. These are power supply terminals.	<b>19-18</b> PB1 probe connection.
<b>4</b>	OUT2 Shared Terminal	<b>21-20</b> PB2 probe connection.
<b>5</b>	N.O. OUT2	<b>23-22</b> PB3 probe connection.
<b>6</b>	N.C. OUT2	<b>23-24</b> PB4 probe connection.
<b>7</b>	OUT3 Shared Terminal	<b>23-25</b> PB5 probe connection.
<b>8</b>	N.C. OUT3	<b>27-26</b> Digital input (DI).
<b>9</b>	N.O. OUT3	<b>28-29</b> LINK <sup>2</sup> . Connection 1 - local area network.
<b>10</b>	OUT1 Shared Terminal	<b>30-31</b> LINK <sup>2</sup> . Connection 2 - local area network.
<b>11</b>	N.O. OUT1	<b>32-33</b> Open Collector Output (OC).
<b>12</b>	Not Used	<b>A</b> TTL Unicard/DMI/Multi Function Key connection
<b>13</b>	OUT4 Shared Terminal	<b>34-35-36</b> RS485. Connection 1 - Supervision Gateway.
<b>14</b>	N.O. OUT4	<b>37-38-39</b> RS485. Connection 2 - Supervision Gateway.

## LED

RTN400 family controllers will also function even if a keyboard has not been connected.

With **KDEPlus** or **KDWPlus** keyboards (which are the same and guarantee the same functions), the display will be as follows:

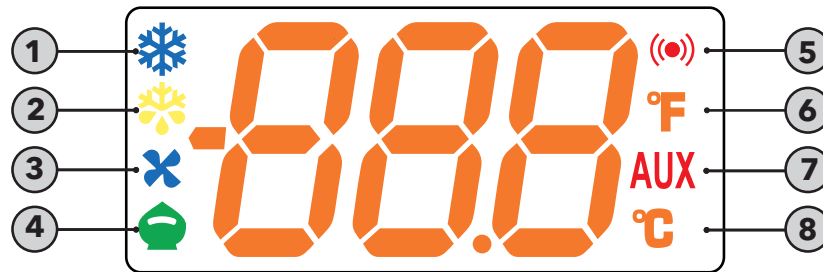

Meaning of LEDs:

No	Icon	LED	Operation	Meaning
1		<b>Compressor</b>	Permanently on	compressor on
			Blinking	Delay, protection or start-up blocked
			OFF	otherwise
2		<b>Defrost</b>	Permanently on	Defrost active
			Blinking	Activated manually or from Digital Input
			OFF	otherwise
3		<b>Fans</b>	Permanently on	Fans active
			OFF	otherwise
4		<b>Reduced SET / Economy</b>	Permanently on	Energy Saving active
			Blinking	Reduced setpoint active
			OFF	otherwise
5		<b>Alarm</b>	Permanently on	alarm active
			Blinking	Alarm acknowledged
			OFF	otherwise
6		<b>°F readout</b>	Permanently on	°F setting (dro = 1)
			OFF	otherwise
7		<b>AUX</b>	Permanently on	Aux output active and/or light on
			Blinking	Deep cooling on
			OFF	otherwise
8		<b>°C readout</b>	Permanently on	°C setting (dro = 0)
			OFF	otherwise

**N.B.:** When the instrument is powered on it performs a lamp test, during which time the display and LEDs will flash for several seconds to check that they all function correctly.

## KDEPLUS BUTTONS

The **KDEPlus** keyboard has 4 keys, as shown in the illustration:

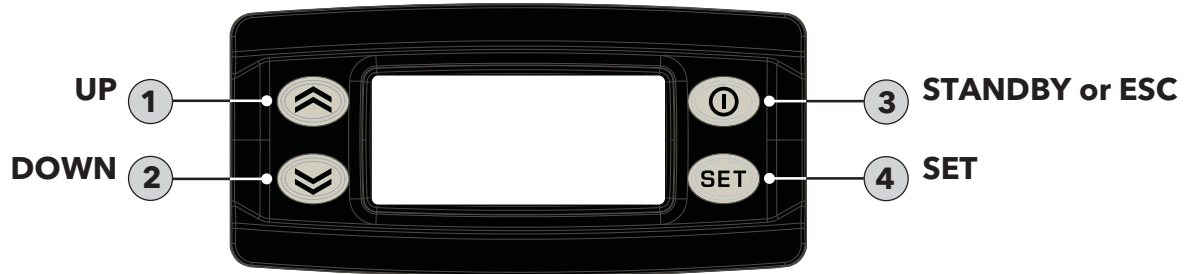





Each key has a different function depending on whether it is:

- Pressed and released
- Pressed for at least 5 seconds
- Pressed and held at start-up
- Pressed in combination with another key.

### KEYS

The following table summarizes the function of each key:

No	Key	Action		
		Pressed and released	Press for at least 5 secs	Start-up
1		<ul style="list-style-type: none"> <li>• Scrolls through menu items</li> <li>• Decreases values</li> </ul>	Activates the <b>Manual Defrost function</b> (from outside menus).	---
2		<ul style="list-style-type: none"> <li>• Scrolls through menu items</li> <li>• Decreases values</li> </ul>	Function can be configured by the user (from outside menus). (see parameter H32)	---
3		<ul style="list-style-type: none"> <li>• Returns to the previous menu level</li> <li>• Confirms parameter value</li> </ul>	Activates the Stand-by function (from outside menus).	---
4		<ul style="list-style-type: none"> <li>• Displays any alarms (if active)</li> <li>• Opens Machine Status menu</li> <li>• Confirms commands</li> </ul>	Opens the Programming Menu (User and Installer parameters)	When pressed during start-up it enables the user to select the application to be loaded.

### SETPOINT: SETTING AND EDIT LOCK

To display the Setpoint value, press the **set** key to enter the "Machine Status" menu, then press the **set** key again when the "SEt" label is displayed.

The Setpoint value appears on the display. To change the Setpoint value, press the **UP** and **DOWN** keys within 15 seconds. Press **set** to confirm the modification.

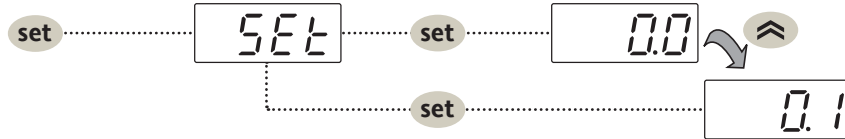

It is possible to disable the keypad on this device.

The keypad can be locked by programming the "LOC" parameter appropriately.

With the keypad locked, you can still access the "Machine Status" menu by pressing **set** to display the Setpoint, but you cannot edit it. To disable the keypad lock, repeat the locking procedure.

### DISPLAY PROBES VALUE

To display the value read by probes connected to the device, press the **set** key and enter the "Machine Status" menu, then press the key again when one of the probe-related labels "Pb1...Pb5" press the **set** key again. The value measured by the associated probe will appear on the display.

**NOTE:** The displayed value is read-only and cannot be modified.

### KDEPLUS BUTTONS

The **KDEPlus** keyboard has 4 keys, as shown in the illustration:



### KEY-ACTIVATED FUNCTIONS

All models have the **UP** key set to enable the "Manual Defrost" function.

The DOWN and ESC keys can also be set to activate any other function required by the user.

The parameters for configuring the two keys are:

- **H11** = DOWN key configuration
- **H33** = ESC key configuration

The values that can be set apply to both keys and the functions that can be activated are:

H32/H33 value	Function to enable
0	disabled
1	defrost
2	reduced set
3	Light
4	Energy saving
5	AUX
6	Stand-by
7	Deep cooling cycle
8	Start/end defrost

TYPICAL SENSOR LOCATIONS

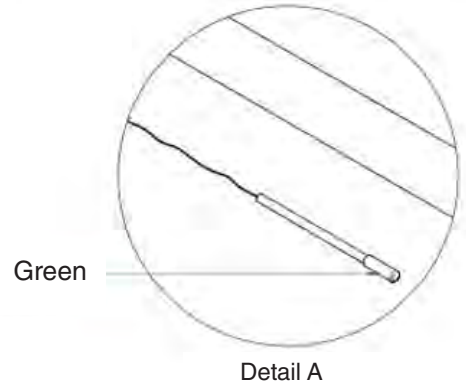
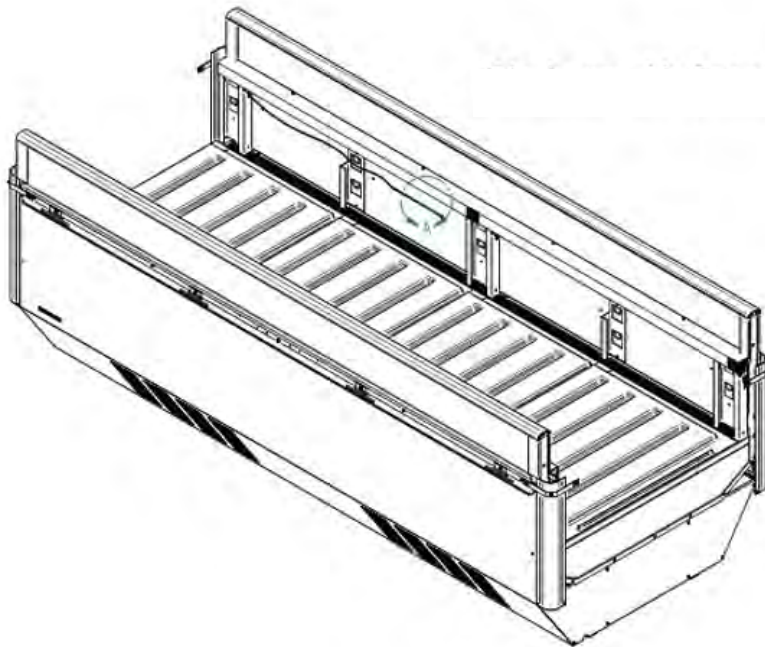

Discharge Air Sensor Location (8-ft case shown)

**NOTE:**

It is critical for merchandiser operating performance to have the sensors in this location. If for any reason, the sensors are removed, they need to be placed in the original location.

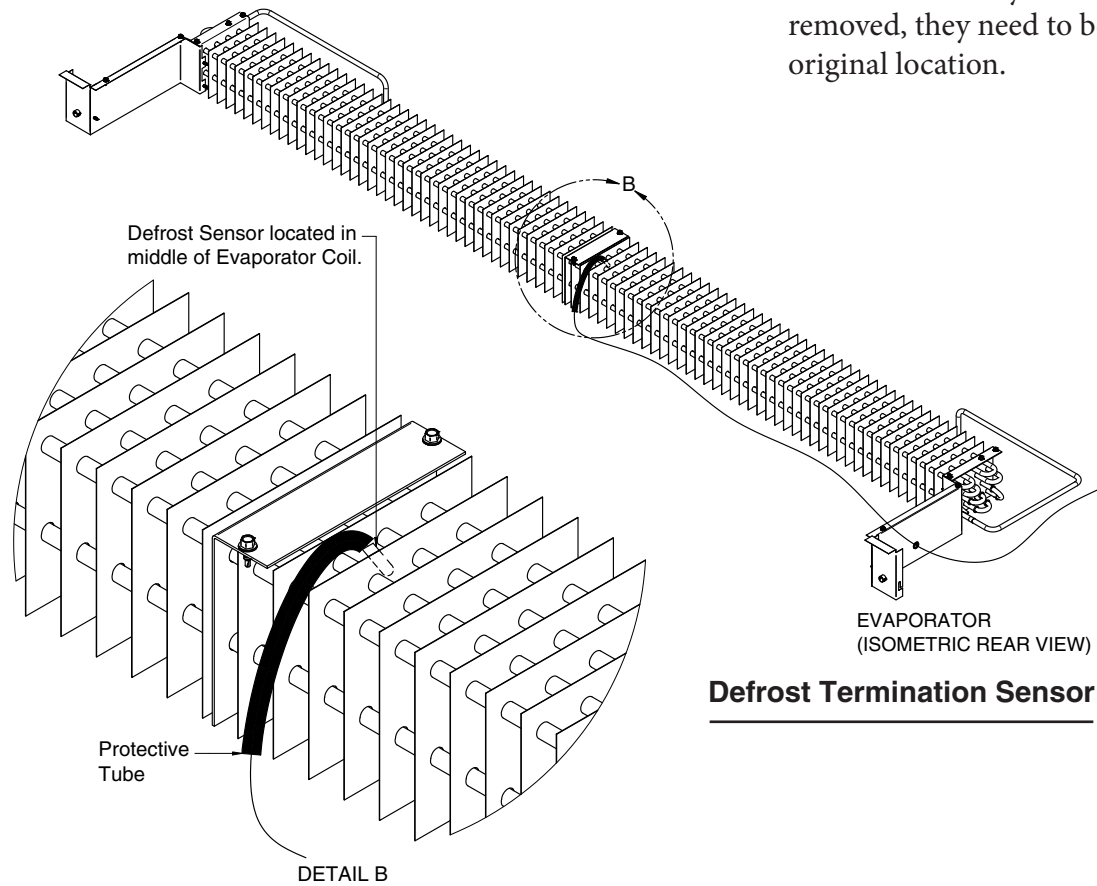

Defrost Termination Sensor

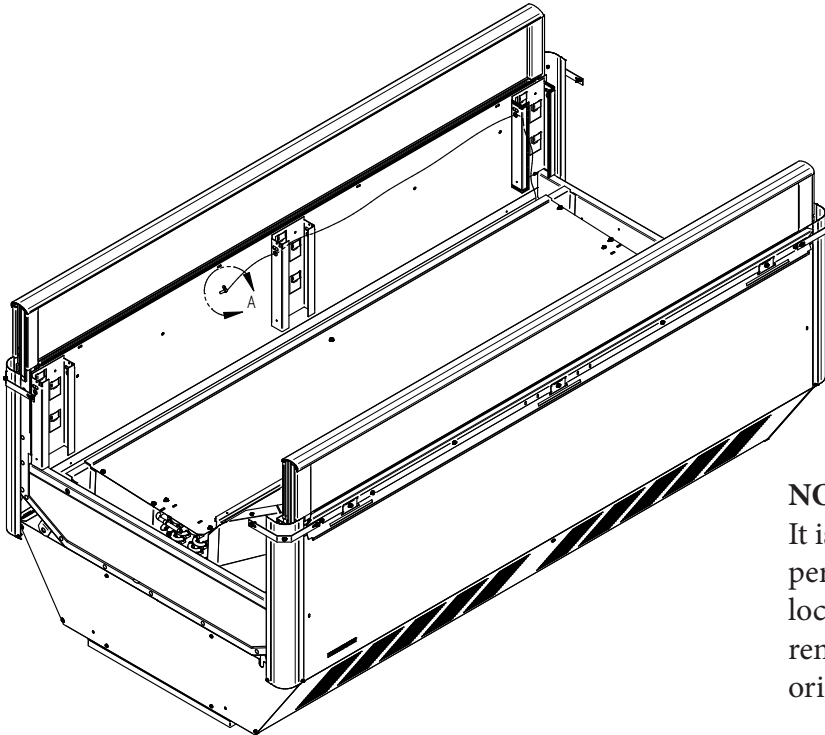

**NOTE:**

It is critical for merchandiser operating performance to have the sensors in this location. If for any reason, the sensors are removed, they need to be placed in the original location.

**Discharge Air Sensor Location (6-ft case shown)**

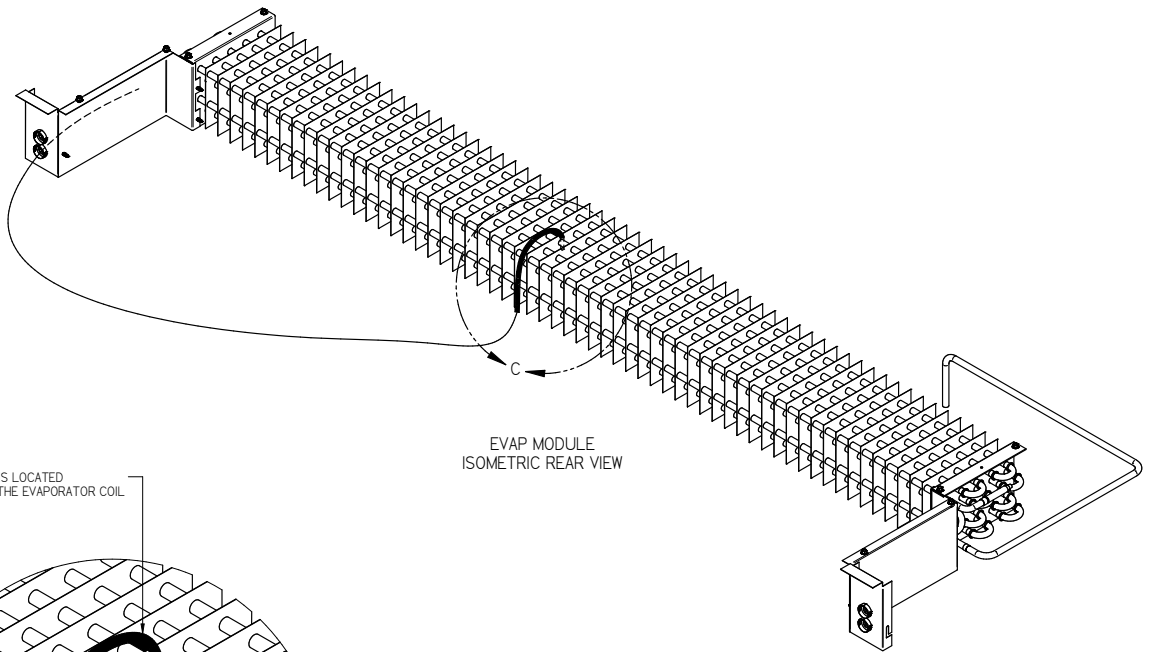

EVAP MODULE  
ISOMETRIC REAR VIEW

DEFROST SENSOR IS LOCATED  
IN THE MIDDLE OF THE EVAPORATOR COIL

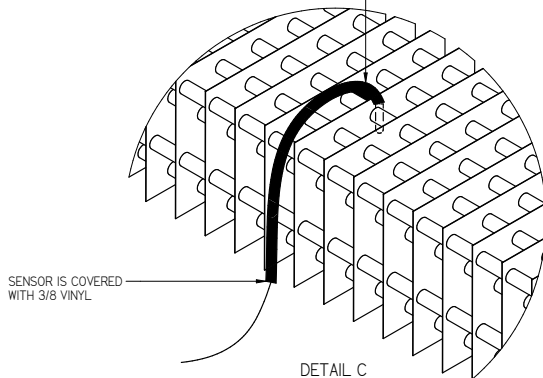

SENSOR IS COVERED  
WITH 3/8 VINYL

DETAIL C

**Defrost Termination Sensor**

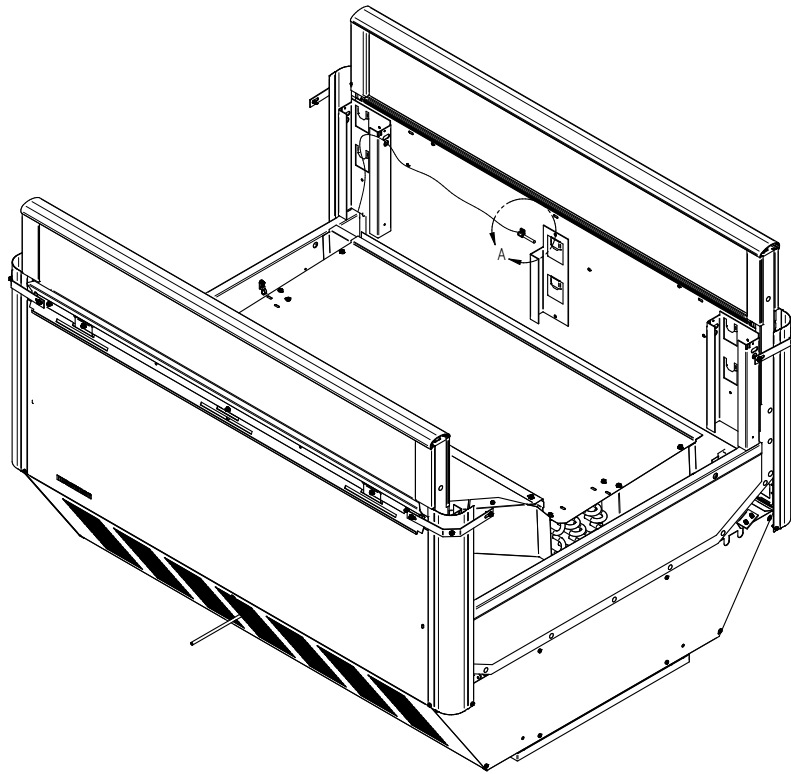

**Discharge Air Sensor Location (4-ft case shown)**

**NOTE:**

It is critical for merchandiser operating performance to have the sensors in this location. If for any reason, the sensors are removed, they need to be placed in the original location.

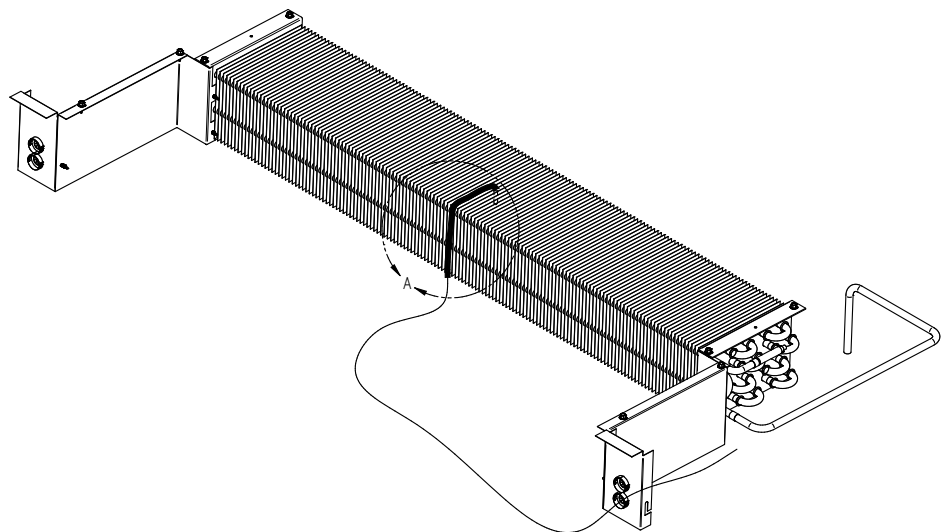

**Defrost Termination Sensor**

EVAP MODULE  
ISOMETRIC REAR VIEW

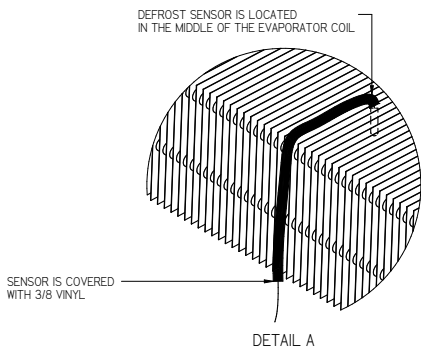

Controls and Adjustments								
Model	Product Application	Discharge Air Temperature	Tripping Dif ( ° F )	Controller Set Point ( ° F )	Defrost Frequency ( per day )	Type of Defrost	Temp. Termination	Failsafe time ( min )
MNGSC8A	Med Temp - DOE , Dairy , Deli	25 ° F to 43 ° F ( -4 ° C to 6 ° C )	18	24 to 25 ° F ( -4 to -3 ° C )	3	Off time	45 ° F ( 7 ° C )	50
	Med Temp - NSF 7 Type 1	21 ° F to 39 ° F ( -6 ° C to 3 ° C )	18	20 to 21 ° F ( -6 to 4 ° C )			45 ° F ( 7 ° C )	
MNGSC6A	Med Temp - DOE , Dairy , Deli	27 ° F to 45 ° F ( -2 ° C to 7 ° C )	18	26 to 27 ° F ( -3 to -2 ° C )	3		45 ° F ( 7 ° C )	50
	Med Temp - NSF 7 Type 1	23 ° F to 41 ° F ( -5 ° C to 5 ° C )	18	22 to 23 ° F ( -6 to -5 ° C )			45 ° F ( 7 ° C )	
MNGSC4A	Med Temp - DOE , Dairy , Deli	27 ° F to 45 ° F ( -2 ° C to 7 ° C )	18	26 to 27 ° F ( -3 to -2 ° C )	3	45 ° F ( 7 ° C )	50	
	Med Temp - NSF 7 Type 1	24 ° F to 42 ° F ( -4 ° C to 5 ° C )	18	23 to 24 ° F ( -3 to -4 ° C )		45 ° F ( 7 ° C )		

Note: The cases are pre-programmed from the factory with controller settings to comply with NSF 7 Type 1 ( 75 ° F 55 % RH )

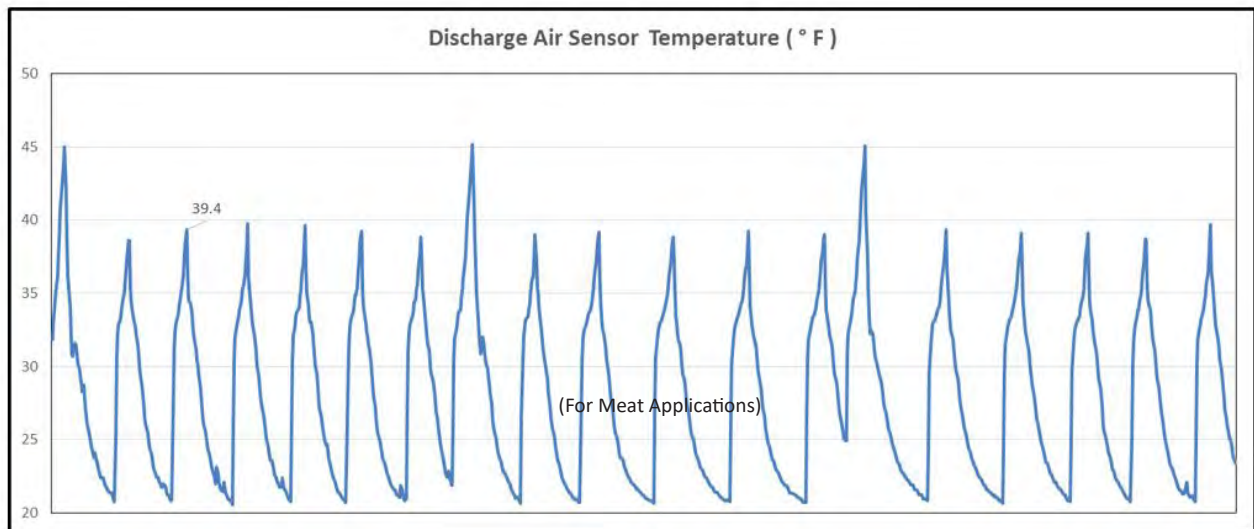

1. The Controller controls refrigeration temperature. This is factory installed in the control panel. Adjust this control to maintain the discharge air temperature shown. Measure discharge air temperatures at the center of the discharge louver.

Defrosts are time initiated and temperature terminated for self contained. The defrost setting is factory set as shown above.

To ensure a thorough defrost, defrost must be terminated by the temperature termination setting — not by time.

## LOAD LIMITS

Each merchandiser has a load limit decal. Shelf life of perishables will be short if load limit is violated.

**AT NO TIME SHOULD MERCHANDISERS BE STOCKED BEYOND THE LOAD LIMITS INDICATED.**



## DO NOT BLOCK AIR LOUVERS.

### Air flow in food compartment:

The main task of the air flow subsystem in the food compartment is to distribute cold air across the display case. Cold discharge air blowing through the honeycomb creates an air curtain that acts as an invisible barrier between the cold air inside and the warm air outside the case. This barrier helps to minimize infiltrations and keeps cold air inside the case. Make sure product is loaded below limit so that the air curtain continues is not disrupted.

## STOCKING

Product should NOT be placed inside the merchandisers until merchandisers are at proper operating temperature.

**Allow merchandiser 24 hours to operate before loading product.**

Proper rotation of product during stocking is necessary to prevent product loss. Always bring the oldest product to the top and set the newest to the bottom.

**AIR DISCHARGE AND RETURN FLUES MUST REMAIN OPEN AND FREE OF OBSTRUCTION AT**

**ALL TIMES** to provide proper refrigeration and air curtain performance. Do not allow product, packages, signs, etc. to block these grilles. Do not use non-approved shelving, baskets, display racks, or any accessory that could hamper air curtain performance.

Do not allow product to be placed outside of the designated load limits in the illustration.

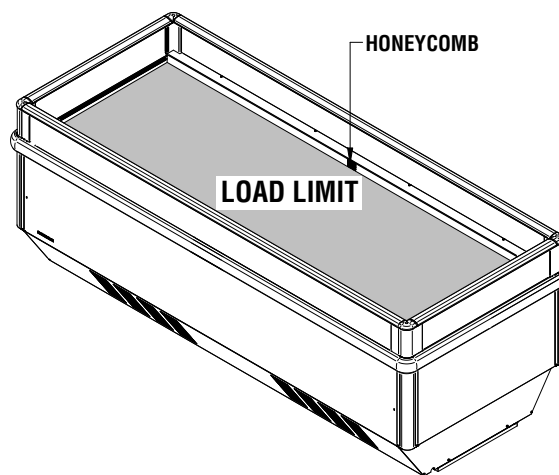
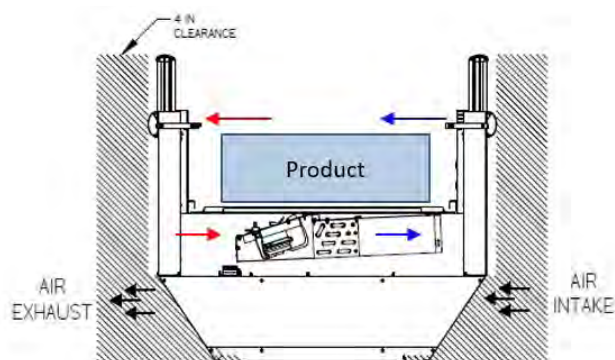

## INSTALLING FDA/NSF REQUIRED THERMOMETER

These models have a thermometer. The thermometer is located at the top, interior of the merchandiser.

# This is an NSF-7 & US FDA Food Code Required Thermometer

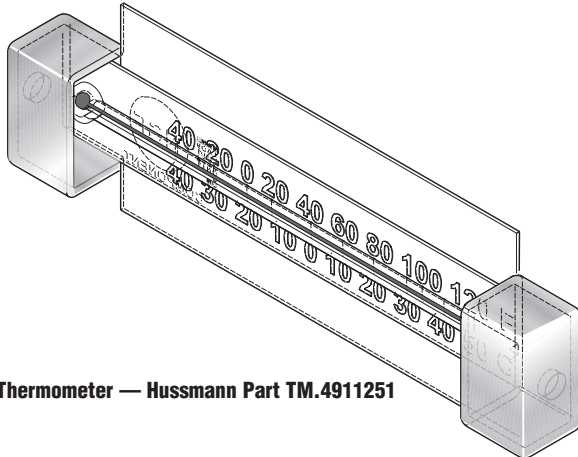

**Thermometer — Hussmann Part TM.4911251**

Hussmann Corporation • 12999 St. Charles Rock Road • Bridgeton, MO 63044-2483  
U.S. & Canada 1-800-922-1919 • Mexico 1-800-890-2900 • www.hussmann.com  
© 2007 Hussmann Corporation

Suggested Mounting Locations  
in Single Deck Glass Front  
Impact Merchandisers

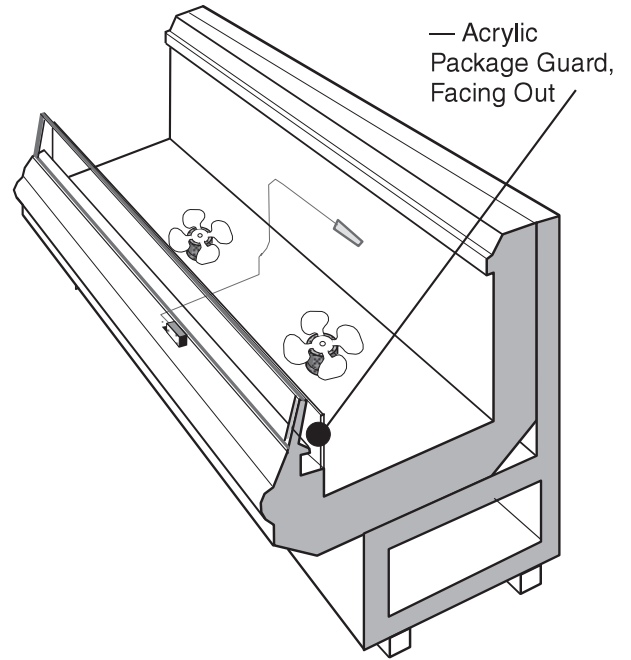

# Important – Please read!

---

This thermometer is provided in response to United States  
Food and Drug Administration (US FDA) Food Code [ <http://www.fda.gov/> ]  
and  
National Sanitation Foundation (NSF / ANSI) Standard 7 [ <http://www.nsf.org/> ]

---

Each installation will be different depending on how the unit is stocked, shopping patterns in the department and ambient conditions of the store. The suggested locations provided herein are possible locations. It is the responsibility of the purchaser / user to determine the location within the food storage area of the unit that best meets the code requirements above.

The thermometer may need to be moved several times to find the warmest location. Mounting options include flexible plastic for price tag molding application, magnet applied to back of flexible plastic for steel end wall, and double stick tape. Tape must not be exposed after installation.

Questions about either code should be addressed to local agencies or other appropriate officials.

---

**Keep with merchandiser  
or give to store manager.  
DO NOT DESTROY.**

## MAINTENANCE

### CARE AND CLEANING

Long life and satisfactory performance of any equipment is dependent upon the care it receives. To ensure long life, proper sanitation and minimum maintenance costs, these merchandisers should be thoroughly cleaned, all debris removed and the interiors washed down, weekly.

#### Exterior Surfaces

The exterior surfaces must be cleaned with a mild detergent and warm water to protect and maintain their attractive finish. **NEVER USE ABRASIVE CLEANSERS OR SCOURING PADS.**

#### Interior Surfaces

The interior surfaces may be cleaned with most domestic detergents, ammonia based cleaners and sanitizing solutions with no harm to the surface. Self contained models empty into a limited capacity evaporation pan, which will overflow if excess water is used in cleaning.

#### ***Do NOT Use:***

- Abrasive cleansers and scouring pads, as these will mar the finish.
- Coarse paper towels on coated glass.
- Ammonia-based cleaners on acrylic parts.
- Solvent, oil or acidic based cleaners on any interior surfaces.
- Do not use high pressure water hoses.

#### ***Do Use:***

- Remove the product and all loose debris to avoid clogging the waste outlet.
- Store product in a refrigerated area such as a cooler. Remove only as much product as can be taken to the cooler in a timely manner.
- Disconnect electrical power before cleaning.**
- Thoroughly clean all surfaces with soap and hot water. **DO NOT USE STEAM OR HIGH WATER PRESSURE HOSES TO WASH THE INTERIOR. THESE WILL DESTROY THE MERCHANDISERS' SEALING CAUSING LEAKS AND POOR PERFORMANCE.**
- Lift hinged fan plenum for cleaning. Hook chain in rear panel to secure plenum during cleaning. **BE SURE TO REPOSITION THE FAN PLENUM AFTER CLEANING MERCHANDISER.**
- Take care to minimize direct contact between fan motors and cleaning or rinse water.
- Do NOT flood merchandiser with water. **NEVER INTRODUCE WATER FASTER THAN THE WASTE OUTLET CAN REMOVE IT.**
- Allow merchandisers to dry before resuming operation.
- After cleaning is completed, turn on power to the merchandiser.

 **WARNING**

**Product will be degraded and may spoil if allowed to sit in a non-refrigerated area.**

 **WARNING**

**Do NOT allow cleaning agent or cloth to contact food product.**

## WARNING

Do NOT use HOT water on Cold glass Surfaces. This can cause the glass to shatter and could result in personal injury. Allow glass fronts, to warm before applying hot water.

### REMOVING SCRATCHES FROM BUMPER

Most scratches and dings can be removed using the following procedure.

1. Use steel wool to smooth out the surface area of the bumper.
2. Clean area.
3. Apply vinyl or car wax and polish surface for a smooth glossy finish.

### CLEANING UNDER FAN PLENUM

To facilitate cleaning, the fan plenum is hinged.

After cleaning be sure the plenum is properly lowered into position OR PRODUCT LOSS WILL RESULT due to improper refrigeration.

## WARNING

— LOCK OUT / TAG OUT —

*To avoid serious injury or death from electrical shock, always disconnect the electrical power at the main disconnect when servicing or replacing any electrical component. This includes, but is not limited to, such items as doors, lights, fans, heaters, and thermostats.*

## WARNING

**SHUT FANS OFF DURING CLEANING PROCESS.**



### CLEANING DISCHARGE AIR HONEYCOMB

Discharge air honeycomb should be cleaned every six months. Dirty honeycomb will cause merchandisers to perform poorly. The honeycomb may be cleaned with a vacuum cleaner. Soap and water may be used if all water is removed from the louvers cells before replacing. Be careful not to damage the honeycomb

1. Remove screws to release retainer. Make sure insulation between honeycomb and cover is placed properly to assure cover surface temperature above dew point.
2. Clean and dry the honeycomb.
3. After cleaning, replace in reverse order. Damaged honeycomb must be replaced.

## CLEANING STAINLESS STEEL SURFACES

Use non-abrasive cleaning materials, and always polish with grain of the steel. Use warm water or add a mild detergent to the water and apply with a cloth. Always wipe rails dry after wetting.

Use alkaline chlorinated or non-chlorine containing cleaners such as window cleaners and mild detergents. Do not use cleaners containing salts as this may cause pitting and rusting of the stainless steel finish. Do not use bleach.

## CLEANING CONDENSER AIR FILTER

The condenser air filter is used only in the MNG8SCA (8-ft case).

4-ft and 6-ft models use a reversible condenser fan feature to clean the condenser.

Condenser filters should be cleaned once per month or depending on the amount of dust and dirt accumulation in the operating environment. A dirty condenser blocks normal airflow through the coils.

Airflow blockage increases energy consumption and reduces the merchandiser's ability to maintain operating temperature.

 <h1 style="margin: 0;">CAUTION</h1>
<p><b>DO NOT FLOOD!</b></p> <p><b>Use only enough water necessary to clean surface. Water must not drip down the case!</b></p>
<p><b>Never use ammonia based cleansers, abrasive cleansers, or scouring pads.</b></p>

1. Vacuum the condenser air filter.  
Unplug the unit, and remove the filter. Vacuum the filter with a hose attachment to remove any debris. If dirt buildup cannot be removed with the vacuum, the filter should be washed.
2. Wash the condenser air filter.  
Soak the filter in water and vinegar for an hour and rinse with water. Do not rinse with high water pressure. Let the filter dry and replace it in the cabinet.
3. Replacing worn air filters.  
Check for damage by inspecting the filter for tears or holes or excessive deposits of dirt that will not wash off. If any of these signs are present, it is time to replace the air filter. Contact your Hussmann representative to purchase new air filters.

Wear Safety Glasses and Gloves  
to perform this maintenance.

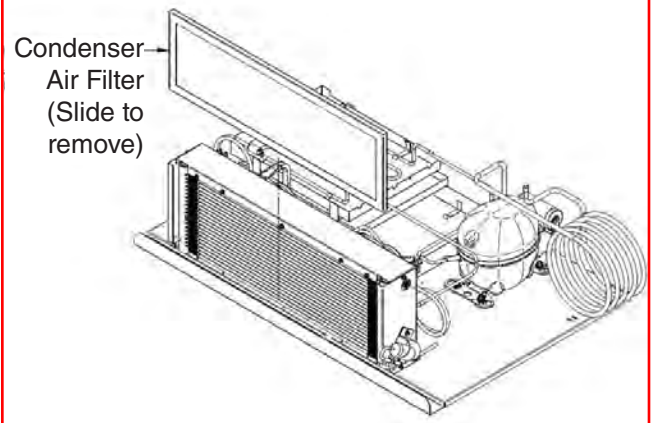
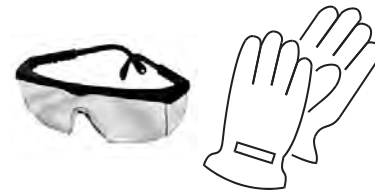

REVERSIBLE CONDENSER FAN FEATURE

During the defrost cycle, the condenser fan is rotating in reversible mode in order to remove any dust or debris located on the condenser fin surface. This feature is available for 4 ft and 6 ft models.

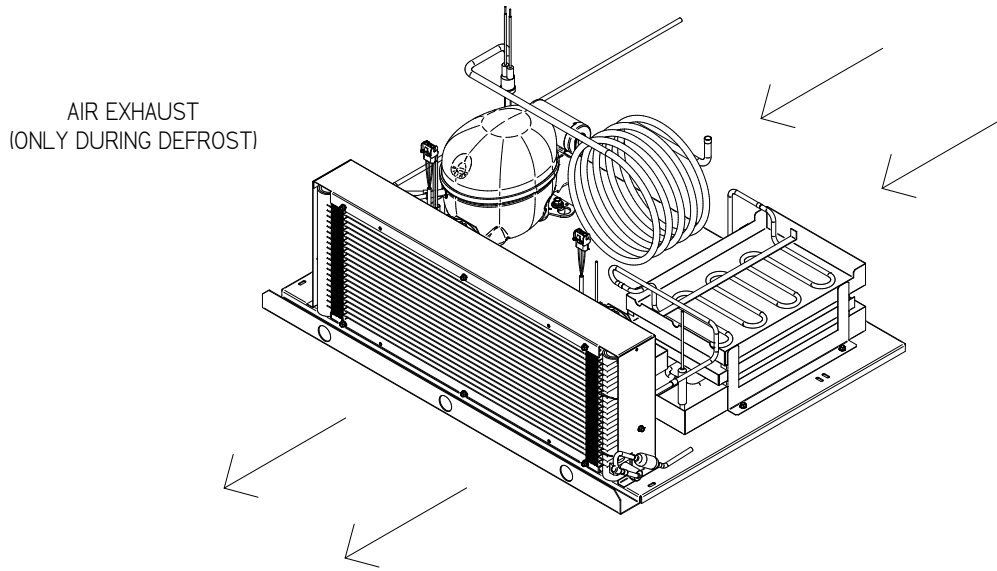

Figure A. Airflow direction during defrost (6-ft Case)

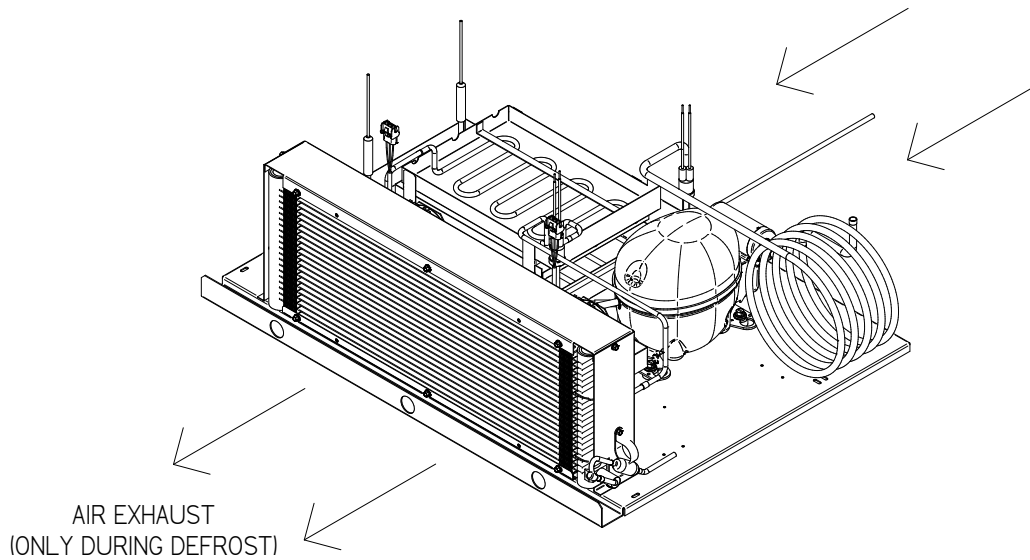

Figure B. Airflow direction during defrost (4-ft Case)

### CLEANING EVAPORATION PAN

The condensate water outlet for self contained models empties into a limited capacity evaporation pan.

Debris or dirt accumulation inside the condensate evaporation pan or on the heater coil will reduce the pan’s evaporation capacity and cause premature heater failure. The evaporation pan waste water will overflow and spill onto the floor if the heater is not properly operating.

Remove accumulated debris from the evaporation pan. Wipe down heater coil with a cloth and warm water. Be sure to remove any dirt, debris or liquids from the heater coil.

Water introduced during cleaning will cause the evaporation pan to overflow.

#### ***NEVER USE SHARP OBJECTS AROUND COILS.***

**Use a soft brush or vacuum brush to clean debris from coils. Do not puncture coils!**

Do not bend fins. Contact an authorized service technician if a coil is punctured, cracked, or otherwise damaged.

**ICE** in or on the coil indicates the refrigeration and defrost cycle is not operating properly. Contact an authorized service technician to determine the cause of icing, and to make adjustments as necessary. To maintain product integrity, move all product to a cooler until the unit has returned to normal operating temperatures.



## CAUTION

Evaporation Pan is Hot!  
and poses risk of bodily injury – Always Wear gloves and protective eye wear when servicing. Turn off evaporation pan heater, and allow pan to cool.



#### PRECAUTION CLEANING PRECAUTIONS

When Cleaning:

- Do not use high pressure water hoses
- Do not introduce water faster than waste outlet can drain
- NEVER INTRODUCE WATER ON SELF CONTAINED UNIT WITH AN EVAPORATION PAN
- NEVER USE A CLEANING OR SANITIZING SOLUTION THAT HAS OIL BASE (these will dissolve the butyl sealants) or an AMMONIA BASE (this will corrode the copper components of the merchandiser)
- TO PRESERVE THE ATTRACTIVE FINISH:
- Use a water and a mild detergent for the exterior only
- Do NOT use a chlorinated cleaner on any surface
- Do NOT use abrasives or steel wool scouring pads (these will mar the finish)

Self-Contained Refrigeration Equipment Maintenance Check List

***** Warranty does not cover issues caused by improper installation or lack of basic preventative maintenance. *****	
Record starting date	
Store Name and Number	
Store Address	
Unit Model Number	
Unit Serial Number	
Contractor/Technician	

	Technician		Q1	Q2	Q3	Q4	Q1	Q2	Q3	Q4
	Quarterly	Semi-Annually								
PM activity-For visual inspection items, denote "ok or complete" in the column to right when PM has been performed. For measured data requested, record data requested in the appropriate column to the right)										
Check in with store manager, record any complaints or issues they have with unit.	X									
Look unit over for any damage, vibrations or abnormal noise.	X									
Verify unit is level side to side and front to rear.	X									
Confirm refrigerant lines properly are secured and not touching or rubbing other lines, wires or frame work.	X									
Verify fan motors and motor mounts are tight.	X									
Confirm fan blade/s are tight and not rubbing or hitting.	X									
Make sure all electrical connections, factory and field, are tight.	X									
Verify electrical connections at lamps are they secure and dry.	X									
Check for and replace any frayed or chaffed wiring.	X									
Check all electrical wiring make sure it is secured and not on any sharp edges or hot lines.	X									
Check for air disturbances external to the unit. Heat and air registers, fans, and doors etc.	X									
Check for water leaks.	X									
Clean evaporator coil/s and fan blade/s. Do not use an acid base cleaner. Rinse off any cleaner residue.		X								
Clean discharge air honeycombs or grilles. Do not use an acid base cleaner. Rinse off any cleaner residue.		X								
Clean condenser coil/s and fan blade/s. Do not use an acid base Cleaner. Rinse off any cleaner residue.		X								
Clean condensate drain pan and drain line.		X								
Verify condensate drain lines are clear and functioning.		X								
Record voltage reading at unit with unit off?		X								
Verify condenser and evaporator fans are working.	X									
Record condenser air inlet temperature	X									
Record condenser air outlet temperature	X									
Is condenser air inlet or air exhaust restricted or recirculating?	X									
Verify there are no visual oil or refrigerant leaks.	X									
Record voltage reading with unit running.		X								
Record compressor amp draw.		X								
Record defrost heater voltage and amp draw.		X								
Record anti-sweat heater voltage and amp draw.		X								
Record case product temperature.	X									
Record unit discharge air temperature.	X									
Record unit return air temperature.	X									
Record ambient conditions around unit (wet Bulb temperature and dry bulb temperature).	X									
Check product loading, do not load beyond the units load limits.	X									
Verify clearances on sides/back of unit.	X									
Check unit controller for proper operation. See controller or 1/0 Manual for proper controller operation.		X								
Confirm door switches function.	X									
Verify unit doors and lids work and are sealed correctly.	X									
Verify that all the panels, shields and covers are in place.	X									

Technician Notes:
-------------------

## SERVICE

### REPLACING EVAPORATOR MOTORS

Should it ever be necessary to service or replace the fan motors be certain that the fan blades are reinstalled correctly. **The blades must be installed with raised embossing (part number on plastic blades) positioned as indicated on the parts list.**

**Unplug power cords before servicing.**

Parts may be ordered at Hussmann's Performance Parts e-store:

<https://parts.hussmann.com/>

or

Call toll free: 855-487-7778

#### Required Tools:

- Screwdriver
- 3/8" Allen Wrench

#### For access to these fans:

1. Remove product and place in a refrigerated area. Make sure the power is off to the case.
2. Make sure there is no voltage in the refrigerator. Remove pan displays to have access to the evaporation section as shown below.

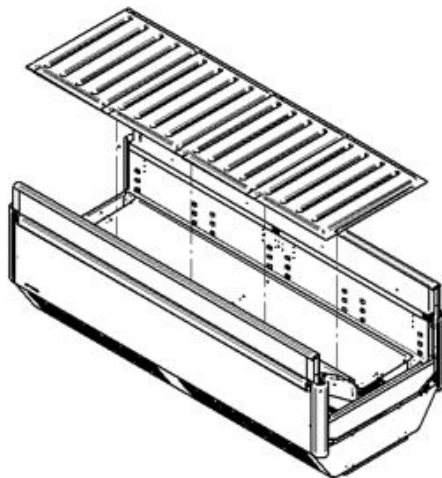

3. Remove motor screws as shown below.

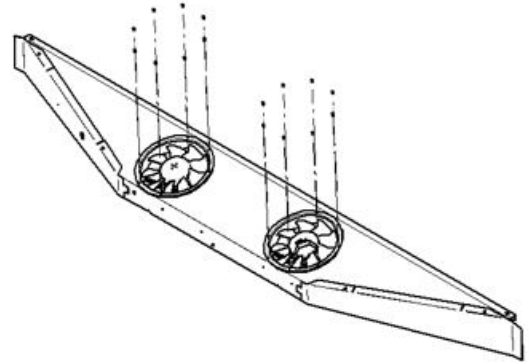

4. Take off motors from assembly and disconnect harness.

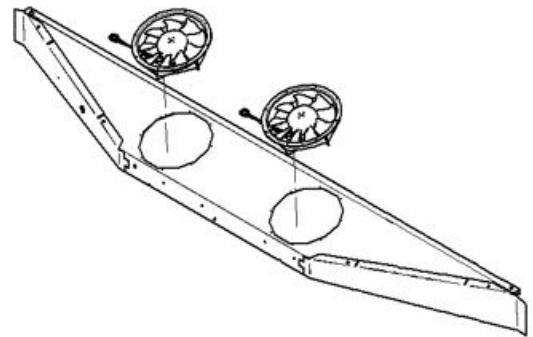

5. Replace new motors and reverse the process. Make sure everything is hand-tight and is working correctly.



## WARNING

— LOCK OUT / TAG OUT —

*To avoid serious injury or death from electrical shock, always disconnect the electrical power at the main disconnect when servicing or replacing any electrical component. This includes, but is not limited to, such items as doors, lights, fans, heaters, and thermostats.*

## TROUBLESHOOTING GUIDE

PROBLEM	PROBABLE CAUSE	SOLUTION
Compressor will not start. (no noise)	<ol style="list-style-type: none"> <li>1. Power disconnected</li> <li>2. Blown fuse or breaker</li> <li>3. Defective or broken wiring</li> <li>4. Defective overload</li> <li>5. Defective temperature control</li> </ol>	<ol style="list-style-type: none"> <li>1. Check service cord or wiring connection</li> <li>2. Replace fuse or reset breaker</li> <li>3. Repair or replace</li> <li>4. Replace</li> <li>5. Replace</li> </ol>
Compressor will not start; cuts out on overload.	<ol style="list-style-type: none"> <li>1. Low voltage</li> <li>2. Defective compressor</li> <li>3. Defective relay</li> <li>4. Restriction (pinched cap tube)</li> <li>5. Restriction (moisture)</li> <li>6. Condenser blocked with dust and dirt</li> <li>7. Defective condenser fan motor</li> </ol>	<ol style="list-style-type: none"> <li>1. Cabinet voltage must not be more than 5% below rating</li> <li>2. Replace</li> <li>3. Replace</li> <li>4. Repair or replace</li> <li>5. Leak check, replace drier evacuate and recharge</li> <li>6. Clean condenser</li> <li>7. Replace</li> </ol>
Warm storage temperature	<ol style="list-style-type: none"> <li>1. Temperature control not set properly</li> <li>2. Short or refrigerant</li> <li>3. Cabinet location too warm</li> <li>4. Refrigerant over-charge</li> <li>5. Low voltage, compressor cycling on overload</li> </ol>	<ol style="list-style-type: none"> <li>1. Reset control. Rotate knob Clockwise</li> <li>2. Leak check, replace drier evacuate and recharge</li> <li>3. Move to cooler location or correct excessive heat source</li> <li>4. Purge system, evacuate and recharge</li> <li>5. Compressor voltage must not be more than 5% below rating</li> </ol>
Compressor runs continuously; product too warm.	<ol style="list-style-type: none"> <li>1. Short of refrigerant</li> <li>2. Inefficient compressor</li> <li>3. Coil iced up</li> </ol>	<ol style="list-style-type: none"> <li>1. Leak check, replace drier, evacuate and recharge</li> <li>2. Replace</li> <li>3. Force manual defrost</li> </ol>
Compressor runs continuously; product too cold	<ol style="list-style-type: none"> <li>1. Defective control</li> <li>2. Control sensing element not in positive contact</li> <li>3. Short on refrigerant</li> </ol>	<ol style="list-style-type: none"> <li>1. Replace</li> <li>2. Assure proper contact</li> <li>3. Leak check, replace drier evacuate and recharge</li> </ol>

## TROUBLESHOOTING GUIDE

PROBLEM	PROBABLE CAUSE	SOLUTION
The refrigeration system is noisy	<ol style="list-style-type: none"> <li>1. Screws and bolts are loose</li> <li>2. The case is not level</li> </ol>	<ol style="list-style-type: none"> <li>1. Make sure bolts and screws are tightened.</li> <li>2. Level the case. use leveling shims if necessary.</li> </ol>
Condensation	<ol style="list-style-type: none"> <li>1. Store temperature or humidity is outside of proper operating conditions.</li> <li>2. Insufficient air circulation</li> <li>3. Hampered air curtain</li> </ol>	<ol style="list-style-type: none"> <li>1. Check case location</li> <li>2. Check the operation of fans and wiring.</li> <li>3. Check electrical connections.</li> <li>4. Make sure air curtain is working properly</li> </ol>
Water leaks; unpleasant odor	<ol style="list-style-type: none"> <li>1. Case drains are obstructed or damaged.</li> <li>2. Water collection tray is sealed incorrectly.</li> <li>3. Water collection tray is sealed incorrectly.</li> <li>4. Water collection tray overflows.</li> </ol>	<ol style="list-style-type: none"> <li>1. Release the drains</li> <li>2. Repair or replace the drains</li> <li>3. Seal piping properly</li> <li>4. Check evaporation heater wiring.</li> <li>5. Check the operation of evaporation heater.</li> </ol>
Frost or ice buildup	<p><i>Inside the cabinet:</i></p> <ol style="list-style-type: none"> <li>1. Fans do not work in the evaporator.</li> <li>2. Sdef probe is detached</li> <li>3. Air currents that alter the circulation of refrigerated air.</li> </ol>	<ol style="list-style-type: none"> <li>1. Check electrical connections.</li> <li>2. Check the ventilation inside the store.</li> </ol>

## APPENDIX A JOINING INSTRUCTIONS

### JOINING INSTRUCTIONS

Sectional construction means that two or more merchandisers may be joined in line yielding one long continuous display requiring only one pair of ends.

**ALL JOINTS MUST BE AIRTIGHT TO PREVENT FORMATION OF ICE OR CONDENSATION.**

#### Prep Merchandiser

1. Check to be sure that merchandisers are level. Insert shims under base as necessary. Locate Joining Kit and check contents.
2. Remove wire racks display pan. Remove front and rear interior base exterior panels for joining. Before removing interior front and back panels, remove the fasteners holding the retainers for the discharge air louvers. (Lift louvers up and out from the bottom.) Remove any return air flue plex-glass parts. (Lift up on interior panels to remove.)
3. Attach brackets to partition using screws, lockwashers, and nuts as shown in Detail A below.

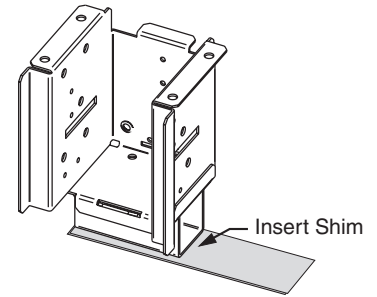

**ATTENTION!**  
See Page 5-10 if joining cases with 2-inch Solid Partition

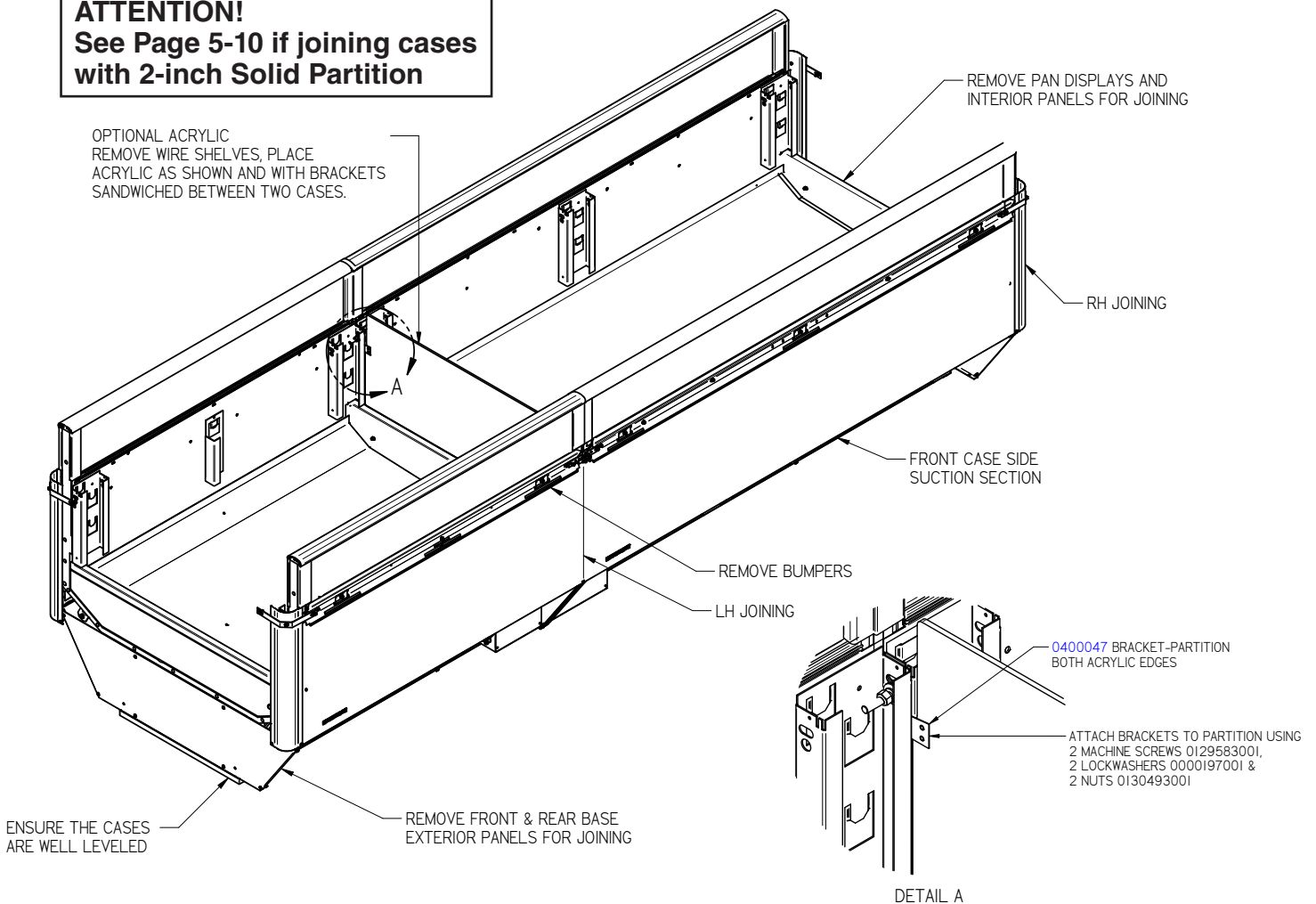

### Apply Gaskets to the Joining Side of Case

1. Apply the 1½ x ½ inch gasket around the perimeter of the merchandiser. It must be at the edge. Check to be sure that there are no gaps between gasket and merchandiser.
2. Apply the 0.906 x ½ inch gasket across the end shoe as shown. Each end of the gasket should extend onto the 1½ inch gasket but not over. Check to be sure that there are no gaps between merchandiser and gaskets.

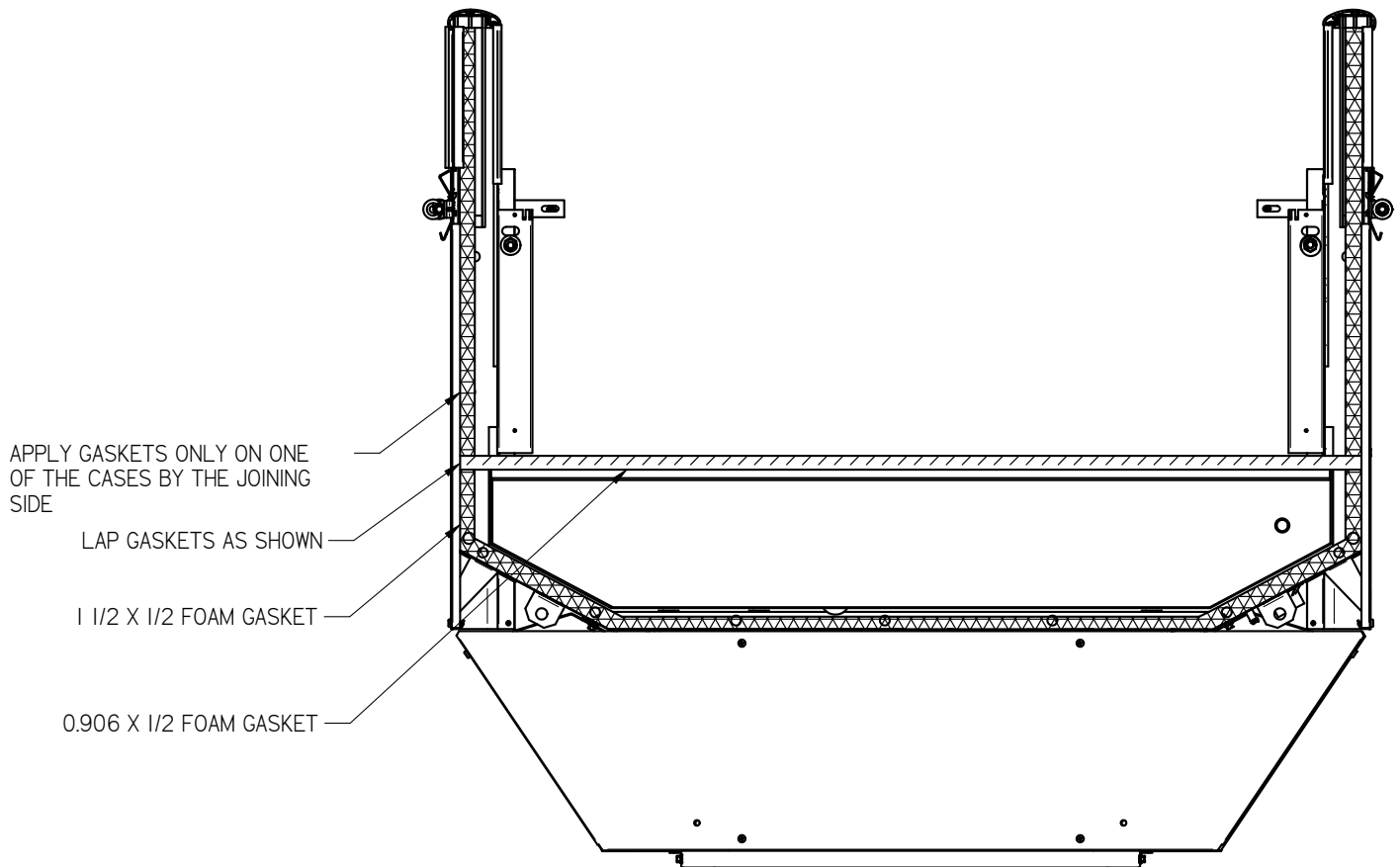

## IMPORTANT

- Do not stretch gasket, especially around corners.
- Do not butt gaskets; always overlap them as shown.
- Remove paper backing after gasket has been applied.
- *Perimeter gasket is required by NSF.*

1. Remove and retain any factory-installed fasteners.
2. *Move merchandisers in lineup as close as possible by pushing or using lever bar (mule).*
3. **Verify upper front panel, front panel, bumper retainer, and top rail alignment *before* joining merchandisers, and shim as necessary. Panels and Top Rail must have equal overhang at each end of merchandiser.**

**NOTE:**

If adding an end case, apply gaskets to the wide island, not the end case.



**NOTE: Merchandisers must be leveled before joining.**

Verify all top rails, panels and bumper retainers of each merchandiser to be joined align vertically before joining.

*To correct vertical alignment of top rails and upper front panel, adjust shims as necessary.*

Verify alignment of panels, bumper retainer and top rail.

Shim cases to ensure vertical alignment of panels and top rails.

Install fasteners.

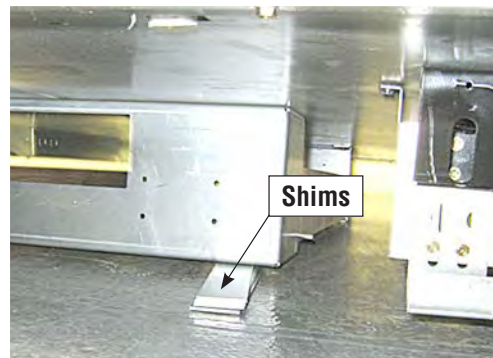

- Align frame fasteners. Loosely assemble bolt, washers, lockwasher and nut as shown here.

**NOTE: Joining hardware is shown enlarged for clarity.**

For glass cases, remove nut retainer clips in one of the case's end frame for each pair of cases joined in the lineup.

**NOTE THAT ALIGNMENT ORDER IS DIFFERENT FROM TIGHTENING ORDER!**

**Do not attempt to draw merchandisers together using nut and bolt.**

**Fasten End Frames**

- Tighten joints in the order shown below until gaskets are compressed, and merchandisers join smoothly.

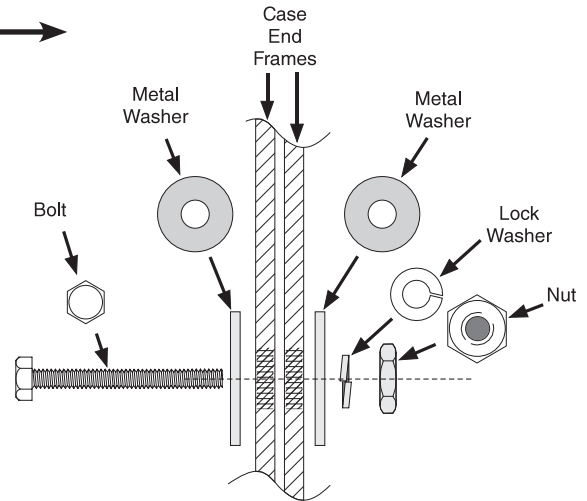

LOCATION SCREW USAGE AND TIGHTENING ORDER		
LOCATION	SCREW PART NUMBER	SCREW DESCRIPTION
1	0014533	SCREW-CAP 5/16-18 X 1 3/4
2	0469689	SCREW-CAP 5/16-18 X 3 1/2
INFERIOR NUMBERS IN BALLOONS INDICATES THE TIGHTEN SEQUENCE ORDER		

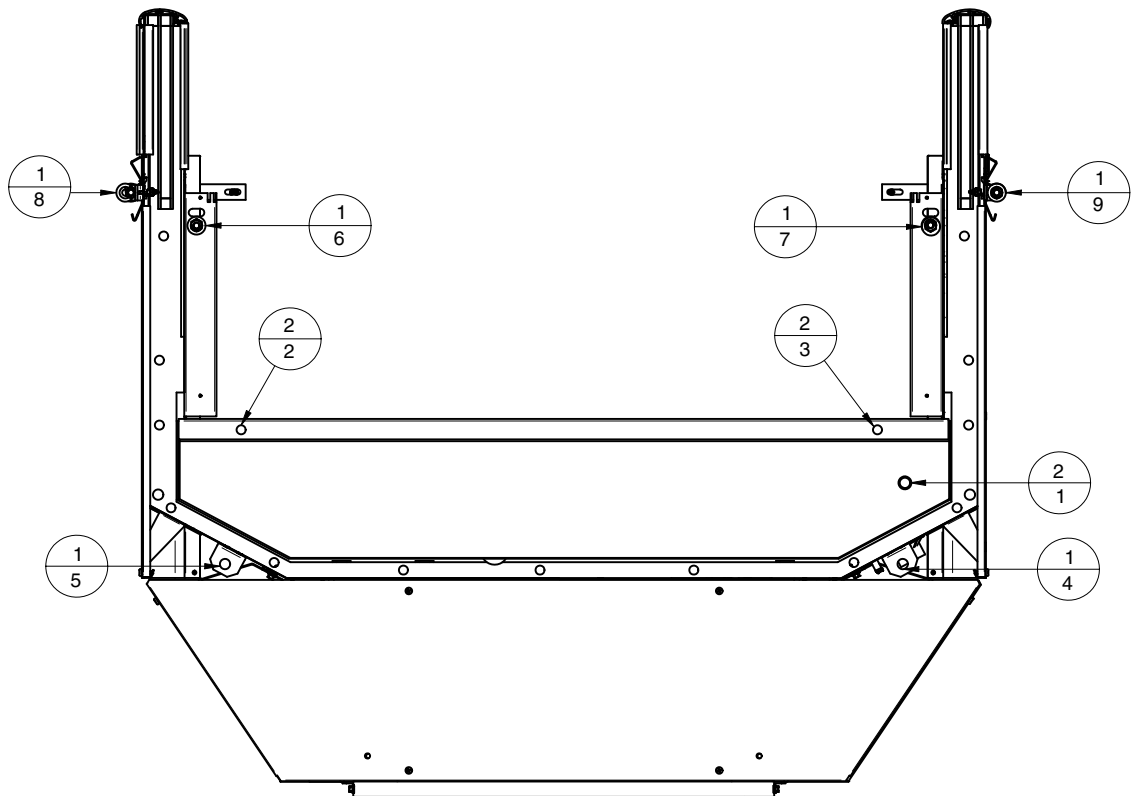

**Join bumper retainers.**

Joining brackets are installed in factory. Be sure to loosen joining bracket screws before tightening and joining the bumper brackets.

2. After tightening the other screws according to the installation sequence shown on the previous page, tighten the screws of joining brackets as shown below.

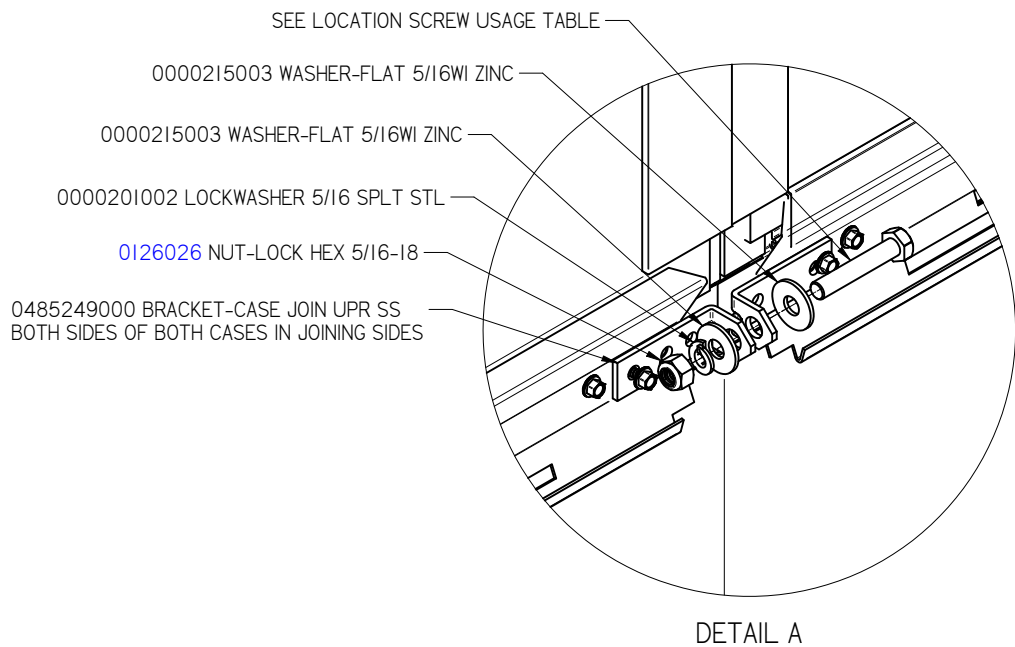
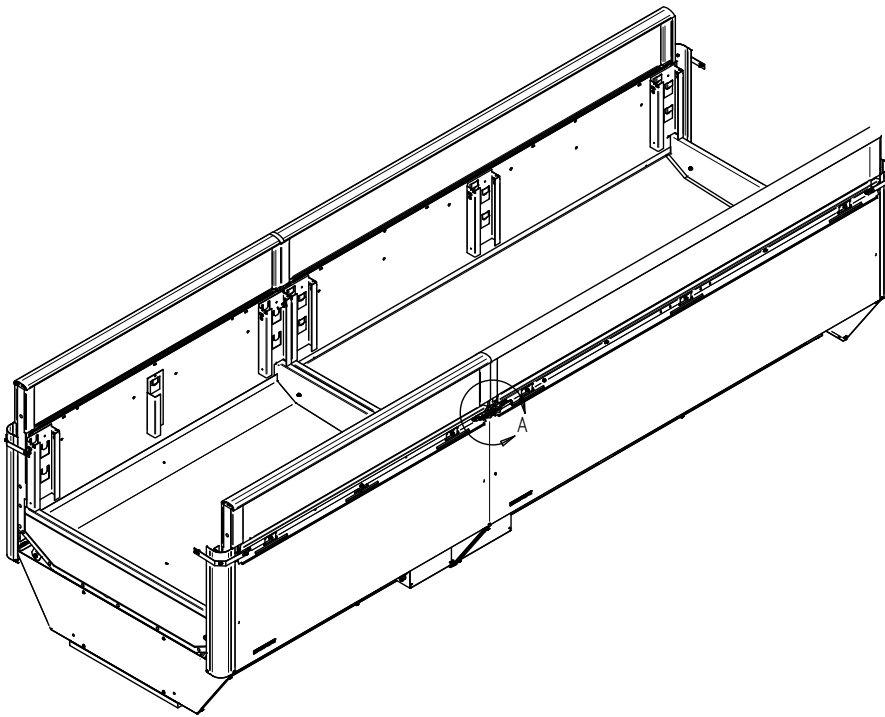

### Attach Joining Panel

2. Attach the joining panel using screws (4) as shown in Detail A below.

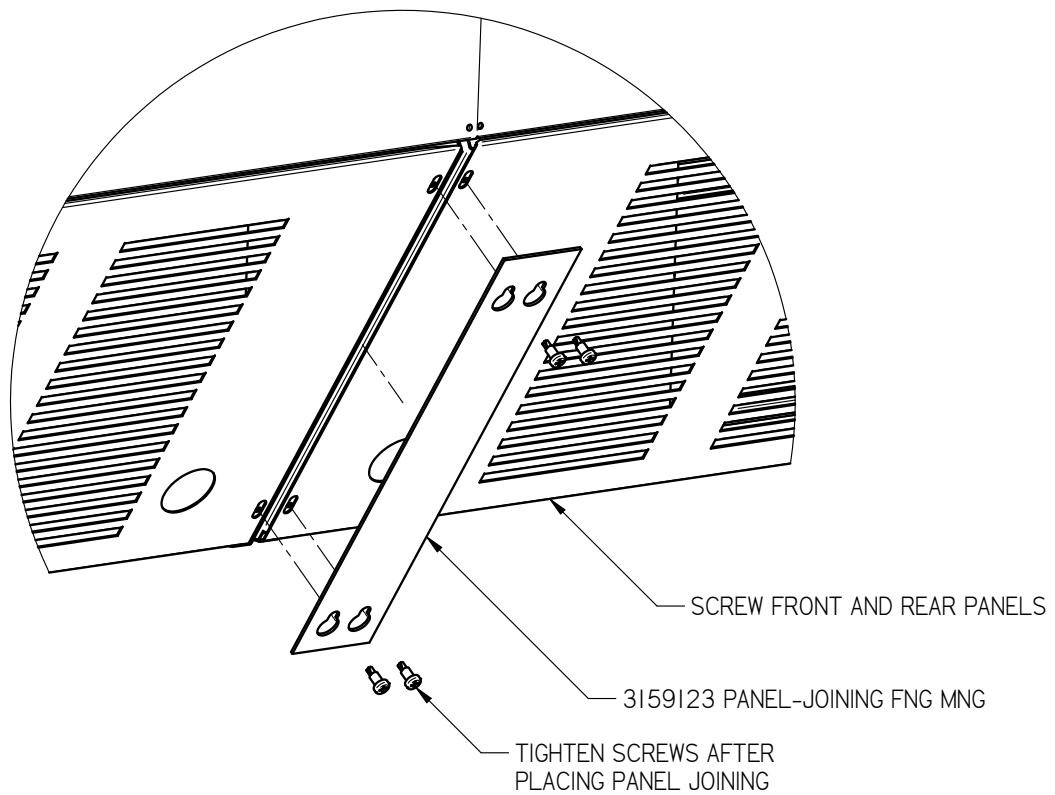
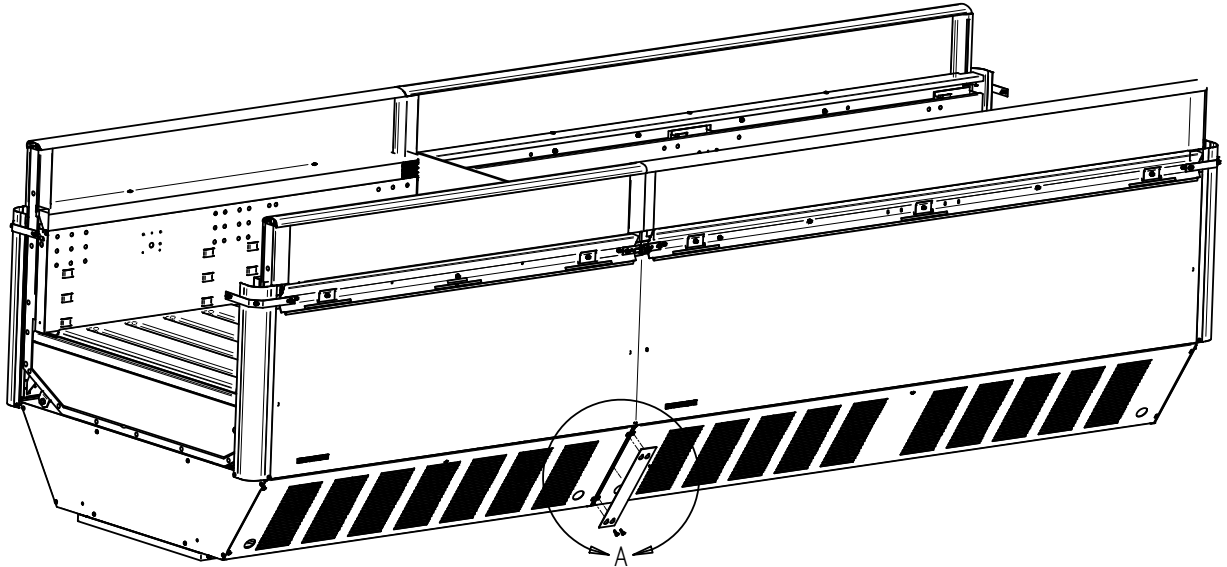

DETAIL A

### If Joining cases with 2-inch Solid Partition

#### Apply gaskets to BOTH sides of cases

1. Apply the 1½ x ½ inch gasket around the perimeter of the merchandiser. It must be at the edge. Check to be sure that there are no gaps between gasket and merchandiser.
2. Apply the 0.906 x ½ inch gasket across the end shoe as shown. Each end of the gasket should extend onto the 1½ inch gasket but not over. Check to be sure that there are no gaps between merchandiser and gaskets.

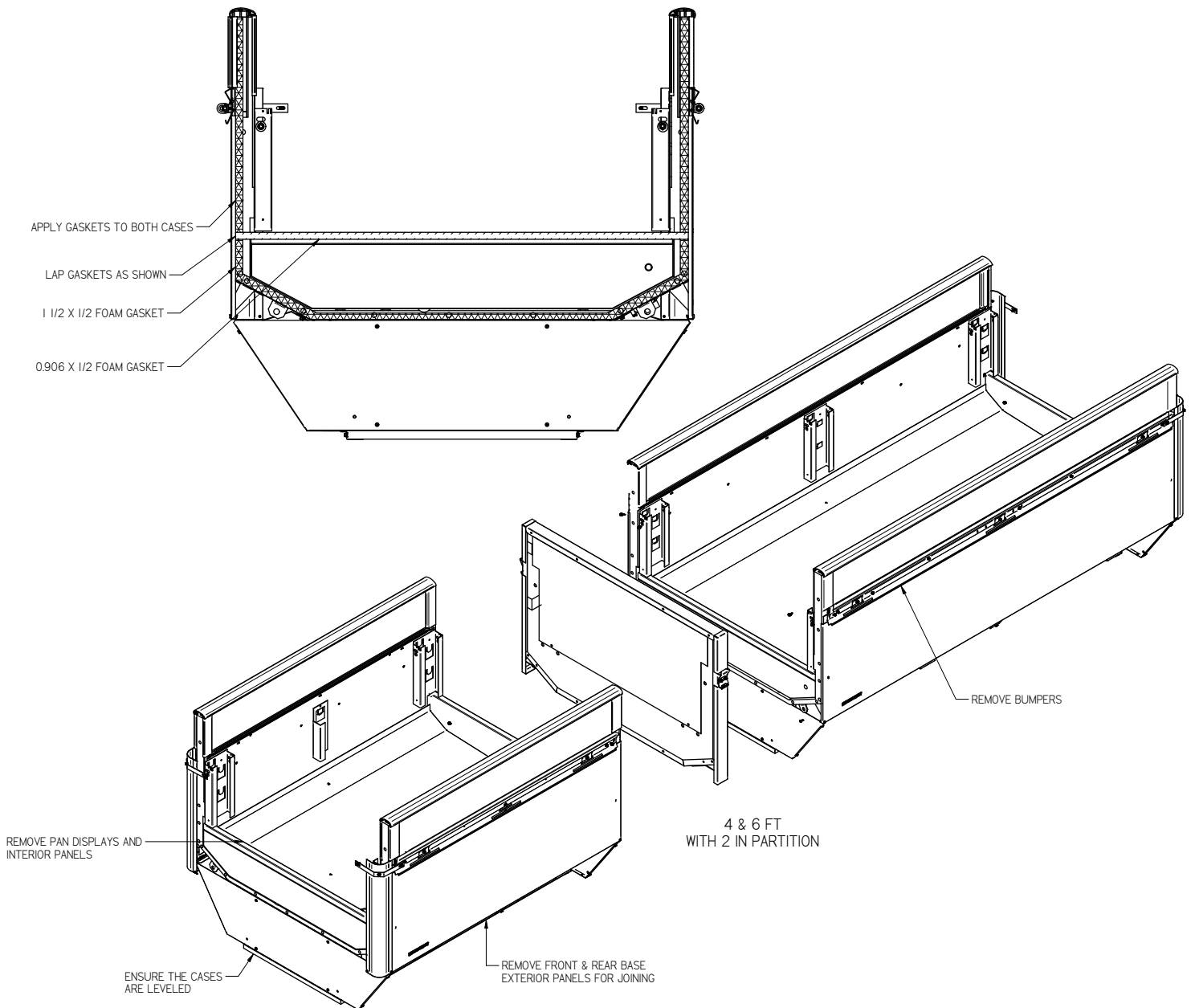

- Align frame fasteners. Loosely assemble bolt, washers, lockwasher and nut as shown here.

**NOTE: Joining hardware is shown enlarged for clarity.**

For glass cases, remove nut retainer clips in one of the case's end frame for each pair of cases joined in the lineup.

**NOTE THAT ALIGNMENT ORDER IS DIFFERENT FROM TIGHTENING ORDER!**

**Do not attempt to draw merchandisers together using nut and bolt.**

**Fasten End Frames as shown below.**

- Tighten joints in the order as shown on Page 5-9 until gaskets are compressed, and merchandisers join smoothly.

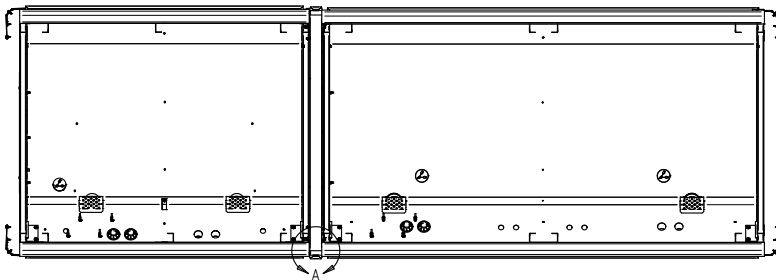
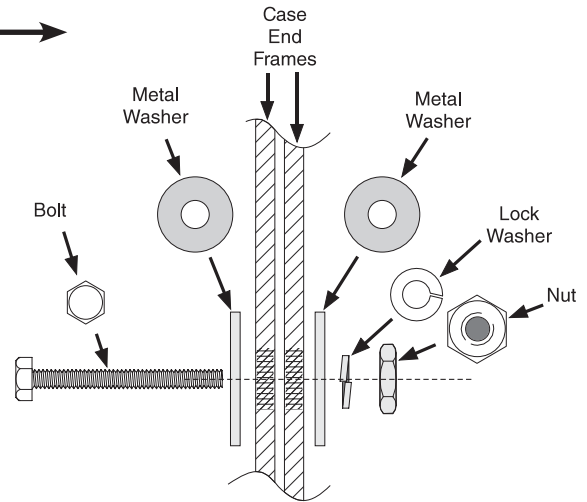

4 & 6 FT WITH 2 IN PARTITION

LOCATION SCREW USAGE		
LOCATION	SCREW PART NUMBER	SCREW DESCRIPTION
1	0486404	BOLT-TAP 5/16-18X4.5 HEX
2	0469689	SCREW-CAP 5/16-18 X 3 1/2

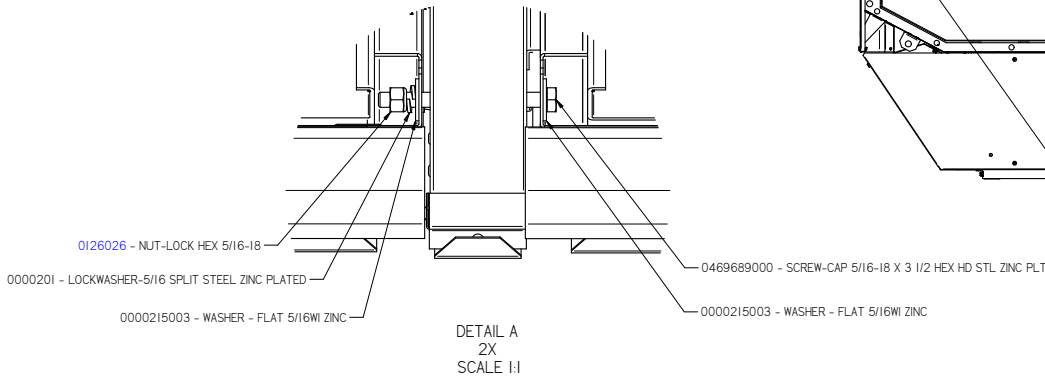
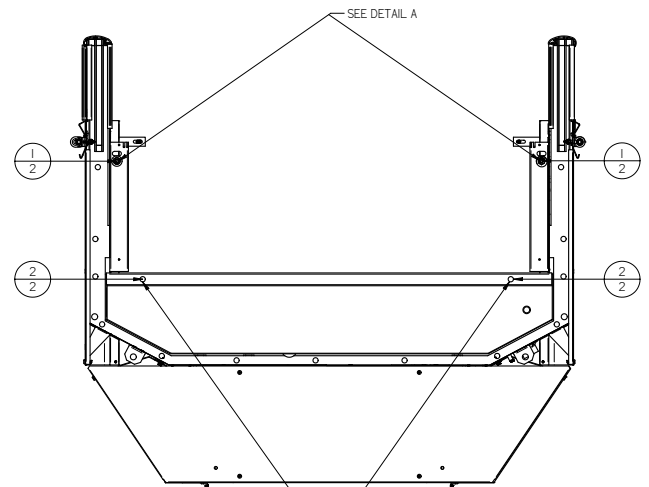

**Attach Joining Panel**

2. Attach the joining panel using screws (4) as shown in Detail B below.
3. Install plastic hand rail trim as shown in Detail C.

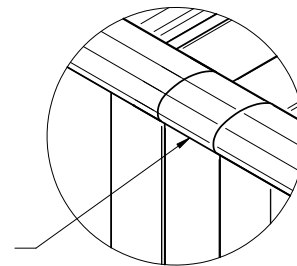
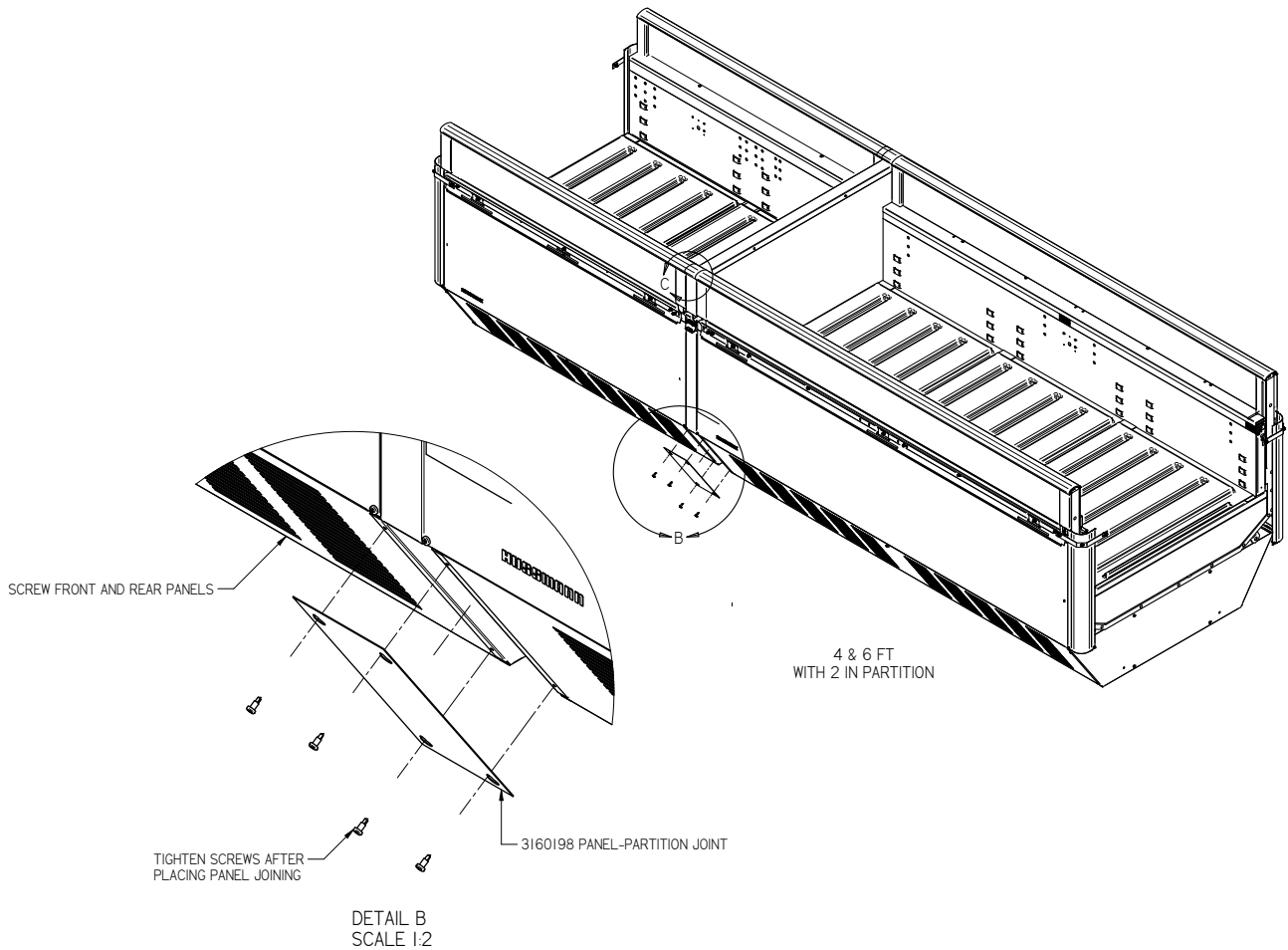

USE FOLLOWING STARTER KITS  
TO COVER GAP BETWEEN CASES.  
PLASTIC HANDRAIL:  
HR91 TRIM-GL/SLD HNDRL STRTER (SILVER)  
IG74 TRIM-HANDRAIL 701 STARTER (BLACK)  
SS HANDRAIL:  
KIG77 TRIM-SS 4" HANDRAIL JOINT



# **HUSSMANN®**

**To obtain warranty information  
or other support, contact your  
Hussmann representative.  
Please include the model and  
serial number of the product.**

*Hussmann Corporation, Corporate Headquarters: Bridgeton, Missouri, U.S.A. 63044-2483 01 October 2012*

**Husmann Corporation**

12999 St. Charles Rock Road

Bridgeton, MO 63044-2483

[www.husmann.com](http://www.husmann.com)