

## **MD4060DA** *Medium Temperature Self Contained Glass Door Vertical Merchandisers*

*with R-290 Refrigerant*

### **WARNINGS:**

If the information in these instructions are not followed exactly, a fire or explosion may result, causing property damage, personal injury or death.

Installation and service must be performed by a qualified installer or service agency.

**READ THE ENTIRE MANUAL BEFORE  
INSTALLING OR USING THIS EQUIPMENT.**

The unit uses R-290 gas as the refrigerant. R-290 is flammable and heavier than air. It collects first in low areas but can be circulated by the fans. If propane gas is present or even suspected, do not allow untrained personnel to attempt to find the cause. The propane gas used in the unit has no odor. The lack of smell does not indicate a lack of escaped gas. If a leak is detected, immediately evacuate all persons from the store, and contact the local fire department to advise them that a propane leak has occurred. Do not let any persons back into the store until the qualified service technician has arrived and that technician advises that it is safe to return to the store. No open flames, cigarettes or other possible sources of ignition should be used inside or in the vicinity of the units.

**FAILURE TO ABIDE BY THIS WARNING COULD  
RESULT IN AN EXPLOSION, DEATH, INJURY AND  
PROPERTY DAMAGE.**

**IMPORTANT**  
Keep in store for future reference!



## **Installation & Operation Manual**



**P/N 3036917\_F**  
October 2024

**Spanish 3036919**



## BEFORE YOU BEGIN

Read these instructions completely and carefully.



### PERSONAL PROTECTION EQUIPMENT (PPE)

Personal Protection Equipment (PPE) is required whenever installing or servicing this equipment. Always wear safety glasses, gloves, protective boots or shoes, long pants, and a long-sleeve shirt.

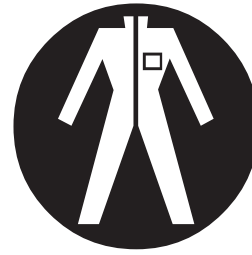
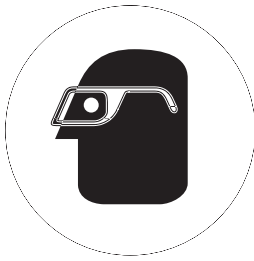

1. If the information in these instructions are not followed exactly, a fire or explosion may result, causing property damage, personal injury or death.
2. Installation and service must be performed by a qualified installer or service agency.
3. This unit is designed only for use with R-290 gas as the designated refrigerant.

#### **THE REFRIGERANT LOOP IS SEALED. ONLY A QUALIFIED TECHNICIAN SHOULD ATTEMPT TO SERVICE!**

- Propane is flammable and heavier than air.
- It collects first in the low areas but can be circulated by the fans.
- If R-290 is present or even suspected, do not allow untrained personnel to attempt to find the cause.
- The propane gas used in the unit has no odor.
- The lack of smell does not indicate a lack of escaped gas.
- If a leak is detected, immediately evacuate all persons from the store, and contact the local fire department to advise them that a propane leak has occurred.
- Do not let any persons back into the store until the qualified service technician has arrived and that technician advises that it is safe to return to the store.
- A hand-held propane leak detector (“sniffer”) shall be used before any repair and/or maintenance.
- No open flames, cigarettes or other possible sources of ignition should be used inside the building where the units are located until the qualified service technician and/or local fire department determines that all propane has been cleared from the area and from the refrigeration systems.
- Component parts are designed for propane and non-incendive and non-sparking. Component parts shall only be replaced with identical repair parts.

**FAILURE TO ABIDE BY THIS WARNING COULD RESULT IN AN EXPLOSION, DEATH, INJURY AND PROPERTY DAMAGE.**

# ATTENTION

Merchandiser must operate for 24 hours  
before loading product!

Regularly check merchandiser temperatures.

Do not break the cold chain. Keep products  
in cooler before loading into merchandiser.

These merchandisers are designed  
for pre-chilled products only.



**IMPORTANT**  
**KEEP IN STORE FOR FUTURE REFERENCE**  
*Quality that sets industry standards!*

12999 St. Charles Rock Road • Bridgeton, MO 63044-2483

U.S. & Canada 1-800-922-1919 • Mexico 800-890-2900

*www.husmann.com*

© 2024 Husmann Corporation

REVISION HISTORY

REVISION F

Updated cover logos.

REVISION E

Added new product warnings, Page 4

REVISION D

Changed relay to 10 Amp, Page 35

REVISION C

Changed Refrigeration Data, Page 37; added California Warning, Page 4; Steps to Recovering Refrigerant, Page 12

REVISION B

Updated number of door torque clicks to 2 or 3

ORIGINAL ISSUE — AUGUST 2017

\*\*\*\*\*  
ANSI Z535.5 DEFINITIONS

 • **DANGER** – Indicate[s] a hazardous situation which, if not avoided, will result in death or serious injury.

 • **WARNING** – Indicate[s] a hazardous situation which, if not avoided, could result in death or serious injury.

 • **CAUTION** – Indicate[s] a hazardous situation which, if not avoided, could result in minor or moderate injury.

• **NOTICE** – *Not related to personal injury* – Indicates[s] situations, which if not avoided, could result in damage to equipment.

 **WARNING**  
Do not use mechanical devices or other means to accelerate the defrosting process.  
Do not use electrical appliances inside the food storage compartments of the case.

 **WARNING**  
Case ventilation openings must be clear of any obstructions. Do not damage the refrigerant circuit.

 **CAUTION**  
Do NOT remove shipping crate until the merchandiser is positioned for installation.

 **CAUTION**  
Excessive ambient conditions may cause condensation and therefore sweating of doors. Facility operators should monitor doors and floor conditions to ensure safety of person.

## NSF LISTING

These merchandisers are manufactured to meet ANSI / UL 471 standard requirements for safety. Proper installation is required to maintain this listing. Near the serial plate, each case carries a label identifying the type of conditions for which the merchandiser was tested.

**ANSI/NSF-7 Type I – Display Refrigerator / Freezer Intended for 75°F / 55% RH Ambient Application**

**ANSI/NSF-7 Type II – Display Refrigerator / Freezer Intended for 80°F / 55% RH Ambient Application**

**ANSI/NSF-7 – Display Refrigerator Intended for Bulk Produce**

## FEDERAL / STATE REGULATION

These merchandisers, at the time they are manufactured, meet all federal and state / provincial regulations.

## HUSSMANN PRODUCT CONTROL

The serial number and shipping date of all equipment is recorded in Hussmann's files for warranty and replacement part purposes. All correspondence pertaining to warranty or parts ordering must include the serial number of each piece of equipment involved. This is to ensure the customer is provided with the correct parts.

## SHIPPING DAMAGE

All equipment should be thoroughly examined for shipping damage before and during unloading. This equipment has been carefully inspected at our factory. Any claim for loss or damage must be made to the carrier. The carrier will provide any necessary inspection reports and/or claim forms.

## Apparent Loss or Damage

If there is an obvious loss or damage, it must be noted on the freight bill or express receipt and signed by the carrier's agent; otherwise, carrier may refuse claim.

## Concealed Loss or Damage

When loss or damage is not apparent until after equipment is uncrated, retain all packing materials and submit a written response to the carrier for inspection within 15 days.

## LOCATION

These merchandisers are designed for displaying products in air conditioned stores where temperature is maintained at or below the ANSI / NSF-7 specified level and relative humidity is maintained at or below 55%.

<p><b>Recommended operating ambient temperature is between 60°F (15.6°C) to 80°F (26.7°C). Maximum relative humidity is 55%.</b></p>
--

Placing refrigerated merchandisers in direct sunlight, near hot tables or near other heat sources could impair their efficiency. Like other merchandisers, these merchandisers are sensitive to air disturbances. Air currents passing around merchandisers will seriously impair their operation. Do NOT allow air conditioning, electric fans, open doors or windows, etc. to create air currents around the merchandiser.

**SELF CONTAINED (LOCATION)**

**MD4060DA** (at 80°F/55% relative humidity, maximum ambient conditions) has front condenser air intake and discharge. Maintain a minimum clearance distance of two feet in front of the merchandiser so that air discharge and air intake is not obstructed.

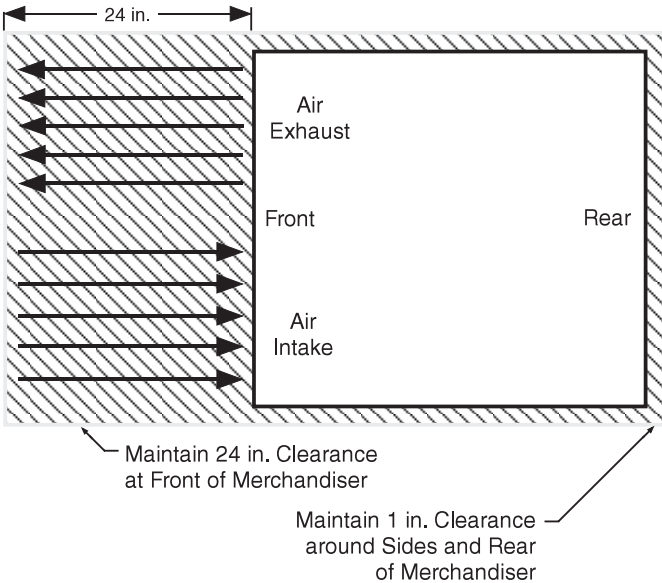

**MODEL DESCRIPTION**

The MD4060DA vertical merchandiser offers versatility in the display of medium temperature (32° F to 41° F) products such as dairy products, prepared salads, pizza and fresh entrees that are pre-chilled in a cooler. Carefully read and follow the instructions prior operating the merchandiser.

**! WARNING**

**— LOCK OUT / TAG OUT —**

*To avoid serious injury or death from electrical shock, always disconnect the electrical power at the main disconnect when servicing or replacing any electrical component. This includes, but is not limited to, such items as doors, lights, fans, heaters, and thermostats.*

**UNLOADING**

**Unloading from Trailer:**

Lever Bar (also known as a Mule, Johnson Bar, J-bar, Lever Dolly, or Pry Lever)

Move the merchandiser as close as possible to its permanent location and remove all packaging. Check for damage before discarding packaging. Remove all separately packed accessories such as kits and shelves.

Improper handling may cause damage to the merchandiser when unloading. To avoid damage:

1. Do not drag the merchandiser out of the trailer. Use a Johnson bar (mule).
2. Use a forklift or dolly to remove the merchandiser from the trailer.

**! CAUTION**

**Do NOT remove shipping crate until the merchandiser is positioned for installation.**

**! WARNING**

**Do NOT stand or walk on top of merchandiser. Do not store items or flammable materials atop the unit.**

## EXTERIOR LOADING

**Do NOT walk on top of merchandisers** or damage to the merchandisers and serious personal injury could occur.

MERCHANDISERS ARE NOT STRUCTURALLY DESIGNED TO SUPPORT EXTERNAL LOADING such as the weight of a person. Do not place heavy objects on the merchandiser.

## SHIPPING SKID

Each merchandiser is shipped on a skid to protect the merchandiser's base, and to make positioning the case easier.

Do not remove the shipping skid until the merchandiser is near its final location. The skid provides protection for both the merchandiser and the floor.

Remove the skid by raising one end of the merchandiser approximately 6 inches. Block the merchandiser securely, and remove the two skid bolts from the raised end. Replace the bolts with (provided) leg levelers. Repeat this procedure at opposing end. Once the leg levelers are secured in place, the merchandiser may be slid off the skid and placed in its final location.

## DO NOT TILT MERCHANDISER ON ITS SIDE OR END WHEN REMOVING SKID.

Once the skid is removed, the merchandiser must be lifted —NOT PUSHED— to reposition.

Check floor where merchandisers are to be set to see if it is a level area. Determine the highest part of the floor.

## MERCHANDISER LEVELING

BE SURE TO POSITION MERCHANDISERS PROPERLY. Level the merchandiser by all four corners. Merchandiser(s) must be installed level to ensure proper operation of the refrigeration system, and to ensure proper drainage of defrost water.

## OPTIONAL LEGS

NSF® approved legs replace the leg levelers if required by local health codes. The legs raise the case 6 inches for cleaning purposes. An optional skirt kit can be provided to snap on the legs.



This warning does not mean that Hussmann products will cause cancer or reproductive harm, or is in violation of any product-safety standards or requirements. As clarified by the California State government, Proposition 65 can be considered more of a 'right to know' law than a pure product safety law. When used as designed, Hussmann believes that our products are not harmful. We provide the Proposition 65 warning to stay in compliance with California State law. It is your responsibility to provide accurate Proposition 65 warning labels to your customers when necessary. For more information on Proposition 65, please visit the California State government website.

**SERIAL PLATE LOCATION**

The serial plate is located on the interior top, left side of the merchandiser. It contains all pertinent information such as model, serial number, amperage rating, refrigerant type and charge. This information will be needed to install, service or order parts for the merchandiser.

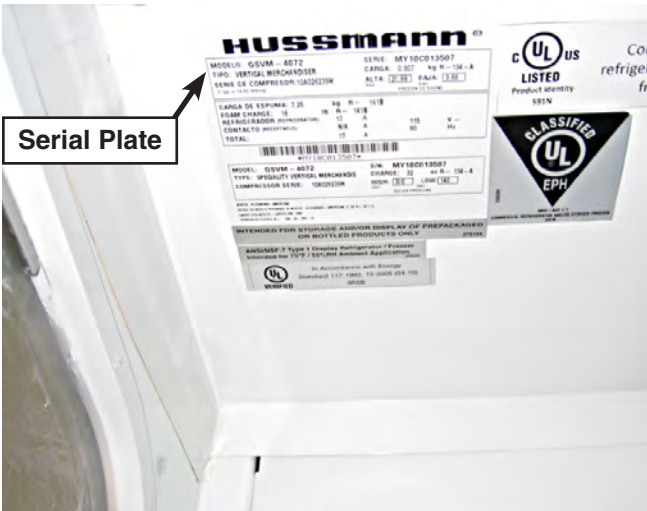

**REFRIGERATION UNIT ACCESS**

The lower front panel may be removed by removing screw at bottom and lifting the panel straight upward and over the tabs on which it is hanging. The panel is installed by reversing the above procedure.

Ensure lower front panel is flat against the floor when installed to prevent air circulation problems for self contained merchandisers.

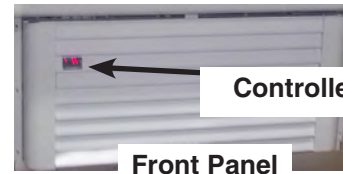

Lift up and out to remove access panel

Display is mounted on left side of access panel. Be careful not to detach RTN400 cable from display when removing access panel.

**SEALING MERCHANDISER TO FLOOR**

If required by local sanitary codes, or if the customer desires, merchandisers may be sealed to the floor using a vinyl cove base trim. The size needed will depend on how much variation there is in the floor, from one end of the merchandiser to the other. Sealing of the lower front and rear panels on self contained models may hamper their removal for servicing or maintenance of the condensing unit.

**NOTE:** Do not allow trim to cover any intake or discharge grilles located in the lower front panel.

**MERCHANDISER ELECTRICAL DATA**

Refer to Appendix A of this manual or the merchandiser’s serial plate for electrical information.

**FIELD WIRING**

Field wiring must be sized for component amperes stamped on the serial plate. Actual ampere draw may be less than specified.

**POWER SWITCH**

The main electrical power switch is located behind the front louvered access panel. The power switch must be turned OFF before servicing the merchandiser.



# WARNING

**Merchandiser must be grounded.  
Do not remove the power supply cord ground.**

## ELECTRICAL CONNECTIONS

All wiring must be in compliance with NEC and local codes. MD-4060DA is provided with a power cord.

**ALWAYS CHECK THE SERIAL PLATE FOR COMPONENT AMPERES**

## ELECTRICAL OUTLET

Before the merchandiser is connected to any wall circuit, use a voltmeter to check that the outlet is at 100% of the rated voltage. The wall circuit must be dedicated for the merchandiser. Failure to do so voids the warranty. Do not use an extension cord. Never plug in more than one merchandiser per electrical circuit.

- Always use a dedicated circuit with the amperage stated on the unit.
- Plug into an outlet designed for the plug.
- Do not overload the circuit
- Do not use long or thin extension cords. Never use adapters.
- If in doubt, call an electrician.

MD4060DA has a factory-installed 5-15P power cord that is attached at the electrical box.

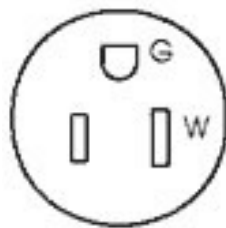

NEMA 5-15P

## WARNING

**Risk of Electric Shock. If cord or plug becomes damaged, replace only with a cord and plug of the same type.**

## REFRIGERATION (Self Contained Models)

Each self contained model is equipped with its own condensing unit and control panel located beneath the display area. The correct type of refrigerant will be stamped on each merchandiser's serial plate. The merchandiser refrigeration piping is leak tested. The unit is charged with refrigerant, and shipped from the factory with all service valves open.

MD4060DA models have a refrigeration system that uses a hermetic compressor. MD4060DA systems use a capillary tube for refrigerant control. The capillary tube is soldered to the suction line pull-out coil for proper heat exchange. **If the capillary should become plugged or damaged, it is best to replace the heat exchanger.**

For self contained models like MD4060DA, this water seal drains into a condensate pan located beneath the merchandiser. **Ensure the drain hose is properly trapped, and the drain area is not clogged.**

**NOTE:** All lower base panels must be in place when the refrigerator is operating. If panels are not in place airflow from the condenser will not be directed over the evaporator pan and defrost water in the pan may overflow.

## Before Beginning Any Service or Repair:

Use a hand-held propane leak detector (“sniffer”) to ensure no propane is present in the immediate area, the inside of the display case and the inside of the refrigeration system. R-290 is an odorless refrigerant. Keep the area clear of all customers and non-essential or unauthorized personnel.

Verify that all repair parts are identical models to the ones they are replacing. Do not substitute parts such as motors, switches, relays, heaters, compressors, power supplies or solenoids. Failure to do so can result in an explosion, death, injury and property damage. Parts used on hydrocarbon cases must meet specific UL certification for non-incendive or non-sparking components. Use only Hussmann approved parts approved through the Hussmann Performance Parts Website. <https://parts.hussmann.com/>

Brazing must not begin before all propane has been cleared from the immediate area — the inside of the displays case and the inside of the refrigeration system.

If a leak is detected, follow store safety procedures. It is the store’s responsibility to have a written safety procedure in place. The safety procedure must comply with all applicable codes such as local fire department’s codes.

At minimum, the following actions are required:

- Immediately evacuate all persons from the store, and contact the local fire department to advise them that a propane leak has occurred.
- Call Hussmann and/or a qualified service agent and inform them that a propane sensor has detected the presence of propane.
- Do not let any persons back into the store until the qualified service technician has arrived and that technician advises that it is safe to return to the store.

## **WARNING**

**Only Hussmann or factory trained technicians should service or repair this R-290 (propane) equipment.**

**Failure to follow instructions can result in an explosion, death, injury and property damage.**

- The propane gas used in the unit has no odor. The lack of smell does not indicate a lack of escaped gas.
- A hand-held propane leak detector (“sniffer”) should be used before any repair and/or maintenance is attempted. All repair parts must be identical models to the ones they are replacing.
- No open flames, cigarettes or other possible sources of ignition should be used inside the building where the units are located until the qualified service technician and/or local fire department determines that all propane has been cleared from the area and from the refrigeration systems.

## REPLACING REFRIGERATION SYSTEM COMPONENTS

### **DANGER**

**Only Hussmann service technicians or technicians qualified to handle R-290 (propane) refrigerant should service or repair this R-290 (propane) equipment. Failure to follow instructions can result in an explosion, death, injury and property damage.**

### STEPS TO RECOVER REFRIGERANT

1. Make sure you are in a well ventilated area before making any service or repair to the refrigeration system.
2. Disconnect all power sources from the system. Some systems may have more than one plug or power supply.
3. Tap system with line tap valves, attaching gauges to the high and low sides of the system.
4. Connect hose to an evacuated recovery tank. Open refrigeration gauges and recovery tank.
5. With the suction valve in vacuum, the refrigerant will be recovered into the recovery tank.
6. Once recovered, close the tank valve and remove the gauge from the tank and connect nitrogen tank to the system to purge it with nitrogen.
7. Pull vacuum to a minimum of 200 microns or lower.



**refrigeration  
line tapping  
valve**

## CHARGING

A calibrated scale with +/-2 gram accuracy must be used to charge the system. The charge amount is shown on the serial plate. Only R-290 grade refrigerant can be used. Standard propane does not meet the purity/moisture content of R-290, and therefore cannot be used to charge cases.

No gas charge adjustments are allowed. When connecting hoses between the refrigeration system, manifold gauges, and refrigerant cylinder, ensure that the connections are secure and there are no potential sources of ignition nearby. Ensure that contamination of different refrigerants does not occur when using charging equipment.

Use dedicated hoses to service R-290 (propane) refrigeration systems. Hoses or lines should be as short as possible to minimize the amount of refrigerant contained in them.

Ensure that the refrigeration system is properly grounded prior to charging the system with refrigerant, to avoid the potential for static build-up.



## WARNING

**Component parts shall be replaced with like components, and servicing shall be done by factory authorized service personnel only, so as to minimize the risk of possible ignition due to incorrect parts or improper service.**

Extreme care must be taken not to overfill the refrigeration system. After charging, carefully disconnect the hoses, attempting to minimize the quantity of refrigerant released. Further leak check the service ports, hoses, refrigerant tanks. The service ports shall be checked for leaks using a hydrocarbon leak detector with a sensitivity of 3 grams/year (0.106 Oz/year) leak rate.

Thoroughly leak check the service ports. If no leak is present, use a pinch-off tool to close the ends of the service tubes before brazing them shut. If a Schrader valve is used on the compressor service tube, it must be removed and the previous steps followed in order to braze the service tube shut.

Typical Sensor to Control Configuration

MD4060DA

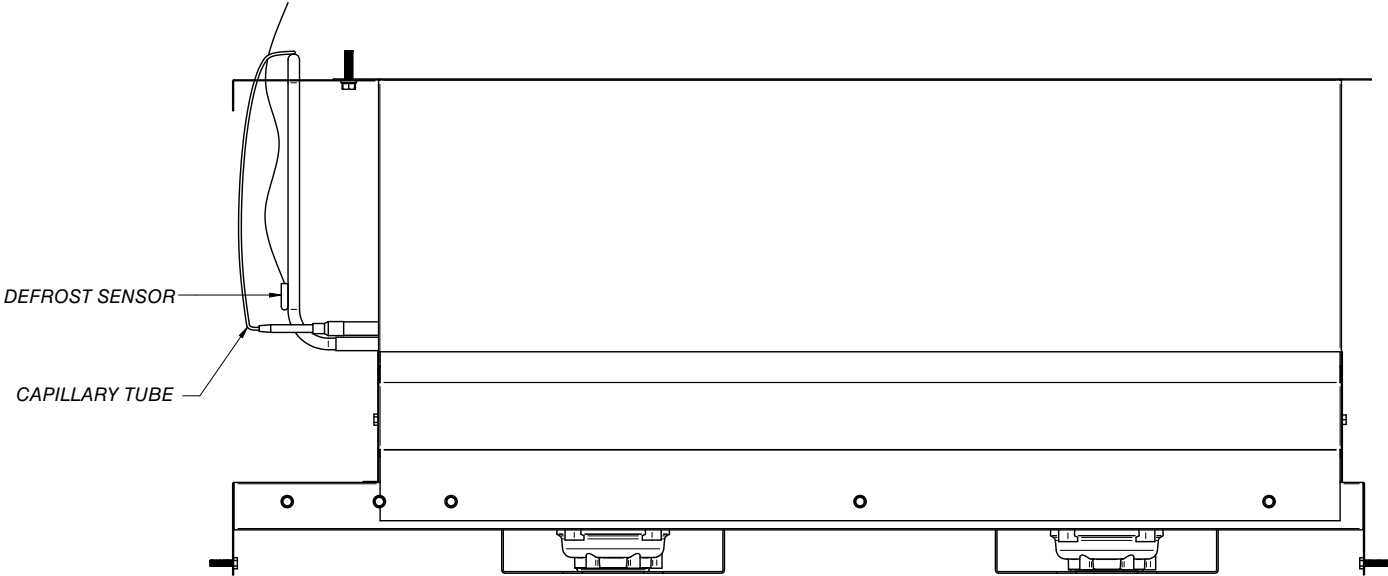
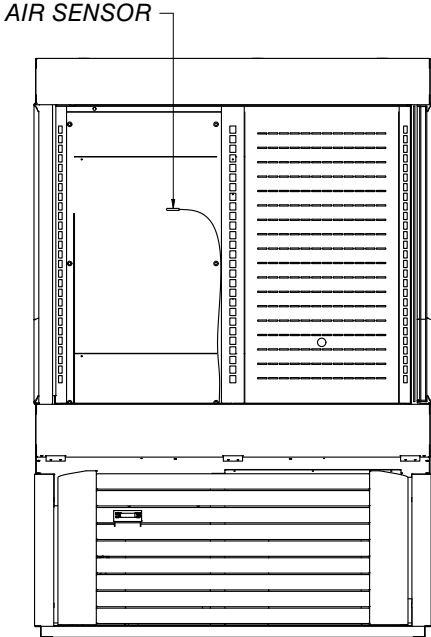

## CONTROLLER

### Hussmann Controller Operation RTN

1. Plug the merchandiser plug into its receptacle.
  - a. The controller display will illuminate.
  - b. The interior light will illuminate.
2. After the control preprogrammed time delay of up to 6 minutes, the compressor and evaporator fan(s) will start if the control is calling for cooling.
3. The control will cycle the compressor but may also cycle evaporator fan(s) on and off determined by the Set-Point and Differential temperatures.
  - a. The Set-Point is the adjustable preprogrammed temperature.
  - b. The Differential is the non-adjustable preprogrammed temperature.
  - c. The Control is designed to read and display a cabinet temperature not a product temperature.

This cabinet temperature may reflect the refrigeration cycle of the Set-Point and it's Differential. The most accurate temperature on a cabinets operation is to verify the product temperature.

Taking as an example a MD4060DA case, freezer, If the Set-Point is -12°F and the Differential is 9°F. (Set-Point) -12°F + 9 (Differential) = -3°F. The compressor and evaporator fan(s) will cycle off -12°F and back on at -3°F.

### Main Features:

- Panel-mounted
- Energy saving algorithms and optimised defrost control
- 8 preloaded applications
- Defrost at single / double evaporator
- Frame Heater
- Local network auto-configuration
- Direct load connection (up to 2 HP)
- Supply voltage control LVD
- Presence of an open collector output



**Key Functions:**

- 2 ON/OFF regulators for HOT/COLD
- Single defrost and double evaporator  
(heatings, modulated heaters, reverse cycle, hot gas)
- Evaporator fans and condenser fans
- Frame Heater
- AUX
- Light
- Door switch
- ON /OFF
- Deep cooling cycle
- Day / Night
- Diagnostics
- “Easy Map” programming
- Programmable inputs/outputs
- LINK2 local area network
- RS485 communication protocol: Modbus
- Compatible with Device Manager (DM)
- Compatible with Unicard and Multi-function key

---

## TECHNICAL DATA

Classification:	electronic automatic control (not safety) device for incorporation
Mounting:	panel mounting
Type of action:	1.B
Pollution class:	2
Material class:	IIIa
Overvoltage category:	II
Nominal pulse voltage:	2500V
Temperature:	Use: -5 ... +55°C - Storage: -30 ... +85°C
Power supply:	SMPS 100-240Va ±10% 50/60 Hz
Power consumption:	5.5W max
Fire resistance category:	D
Software class:	A
RTC battery life:	In absence of external power, the clock battery will last 3 years.

## FURTHER INFORMATION

### INPUT CHARACTERISTICS

Measurement range:	<b>NTC:</b> -50.0°C ... +110°C; <b>PTC:</b> -55.0°C ... +150°C; <b>PT1000:</b> -60.0°C ... +150°C (on 3-digit display with +/- sign)
Accuracy:	±1.0° for temperatures below -30°C ±0.5° for temperatures between -30°C and +25°C ±1.0° for temperatures above +25°C
Resolution:	1 or 0.1°C
Buzzer:	NO
Analogue/Digital Inputs:	5 configurable NTC/PTC/PT1000/DI inputs 1 multi-function, voltage-free digital input (D.I.)

### OUTPUT CHARACTERISTICS

Digital Outputs:	<b>OUT1:</b> 1 SPST relay: 2HP max 240V~
	<b>OUT2:</b> 1 SPDT relay: 1HP max 250V~
	<b>OUT3:</b> 1 SPDT relay: 8(4)A max 250V~
	<b>OUT4:</b> 1 SPST relay: 8(4)A max 250V~
OC (Open Collector) Output:	<b>OC:</b> 1 multifunctional output: 12V= 20mA

### MECHANICAL CHARACTERISTICS

Dimensions:	121x92 mm
Terminals:	FASTON and screw for wires with cross-section of
Connectors:	2.5mm <sup>2</sup> TTL for Unicard / Device Manager connection
Humidity:	(via DMI) Usage / Storage: 10...90% RH (non-condensing)

### REGULATIONS

Electromagnetic compatibility:	The device complies with Directive 2004/108/EC
Safety:	The device complies with Directive 2006/95/EC
Food Safety:	The device complies with standard EN13485 as follows: <ul style="list-style-type: none"> <li>• Suitable for storage.</li> <li>• Application: air.</li> <li>• Climate range A</li> <li>• measurement class 1 in the range from -25°C to 15°C (*)</li> </ul> <b>(* with Eliwell probes only)</b>

**NOTE:** The technical specifications stated in this document regarding measurement (range, accuracy, resolution, etc.) refer to the instrument alone and not to any accessories provided, such as the probes. This means, for example, that the error introduced by the probe must be added to the error of the instrument.

# CONNECTIONS

## TERMINALS

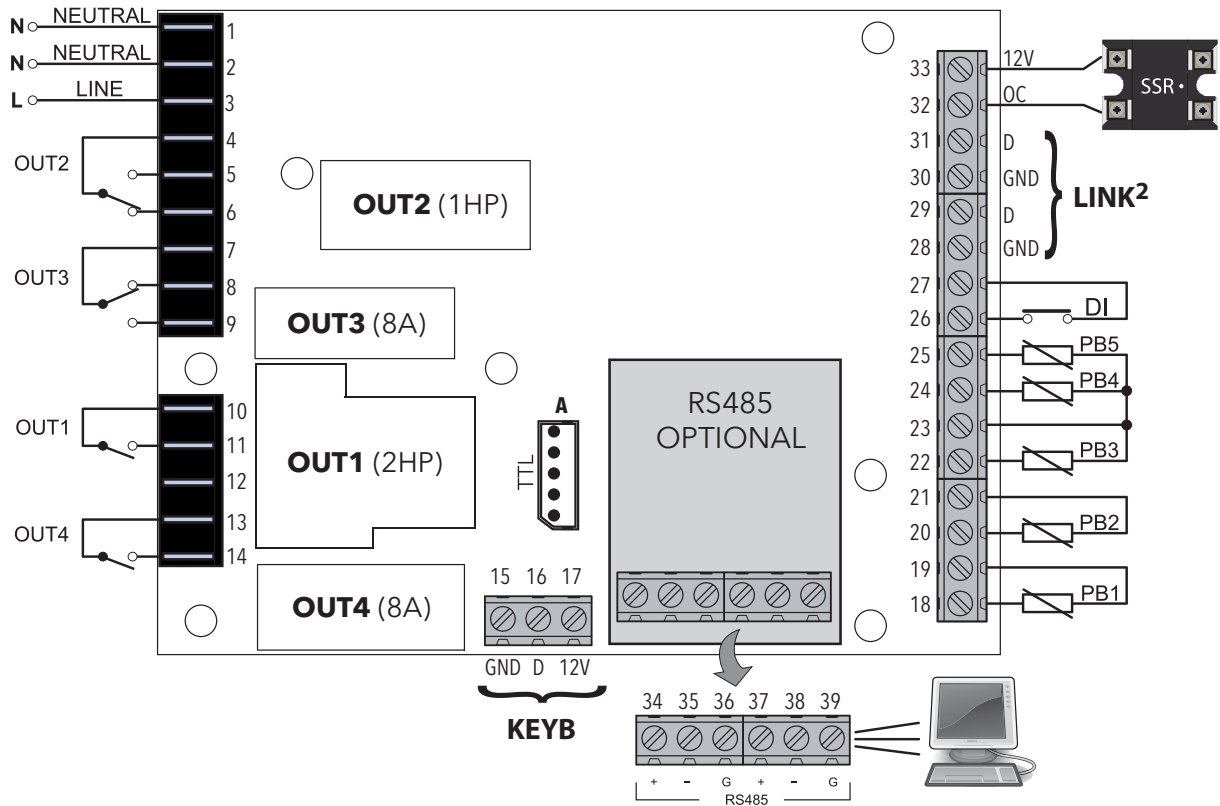

\* **N.B.:** analogue inputs PB1...PB5 can also be configured as Digital Inputs DI.

TERMINALS			
<b>1-2</b>	NEUTRAL. These are power supply terminals.	<b>15-16-17</b>	Connection to KDEPlus or KDWPlus external keyboard or ECPlus echo module.
<b>3</b>	LINE. These are power supply terminals.	<b>19-18</b>	PB1 probe connection.
<b>4</b>	OUT2 Shared Terminal	<b>21-20</b>	PB2 probe connection.
<b>5</b>	N.O. OUT2	<b>23-22</b>	PB3 probe connection.
<b>6</b>	N.C. OUT2	<b>23-24</b>	PB4 probe connection.
<b>7</b>	OUT3 Shared Terminal	<b>23-25</b>	PB5 probe connection.
<b>8</b>	N.C. OUT3	<b>27-26</b>	Digital input (DI).
<b>9</b>	N.O. OUT3	<b>28-29</b>	LINK <sup>2</sup> . Connection 1 - local area network.
<b>10</b>	OUT1 Shared Terminal	<b>30-31</b>	LINK <sup>2</sup> . Connection 2 - local area network.
<b>11</b>	N.O. OUT1	<b>32-33</b>	Open Collector Output (OC).
<b>12</b>	Not Used	<b>A</b>	TTL Unicard/DMI/Multi Function Key connection
<b>13</b>	OUT4 Shared Terminal	<b>34-35-36</b>	RS485. Connection 1 - Supervision Gateway.
<b>14</b>	N.O. OUT4	<b>37-38-39</b>	RS485. Connection 2 - Supervision Gateway.





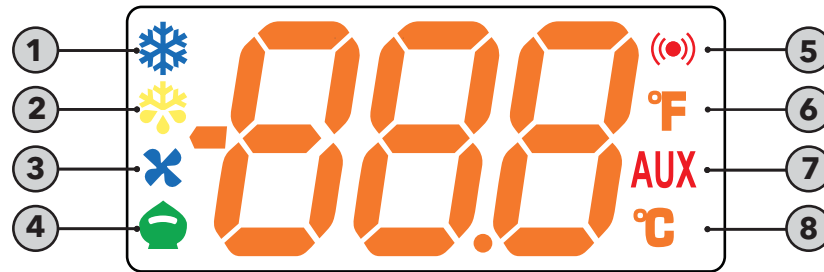

## LED

RTN400 family controllers will also function even if a keyboard has not been connected.

With **KDEPlus** or **KDWPlus** keyboards (which are the same and guarantee the same functions), the display will be as follows:



Meaning of LEDs:

No	Icon	LED	Operation	Meaning
1		<b>Compressor</b>	Permanently on	compressor on
			Blinking	Delay, protection or start-up blocked
			OFF	otherwise
2		<b>Defrost</b>	Permanently on	Defrost active
			Blinking	Activated manually or from Digital Input
			OFF	otherwise
3		<b>Fans</b>	Permanently on	Fans active
			OFF	otherwise
4		<b>Reduced SET / Economy</b>	Permanently on	Energy Saving active
			Blinking	Reduced setpoint active
			OFF	otherwise
5		<b>Alarm</b>	Permanently on	Alarm active
			Blinking	Alarm acknowledged
			OFF	otherwise
6		<b>°F readout</b>	Permanently on	°F setting (dro = 1)
			OFF	otherwise
7	<b>AUX</b>	<b>AUX</b>	Permanently on	Aux output active and/or light on
			Blinking	Deep cooling on
			OFF	otherwise
8		<b>°C readout</b>	Permanently on	°C setting (dro = 0)
			OFF	otherwise

**N.B.:** When the instrument is powered on it performs a lamp test, during which time the display and LEDs will flash for several seconds to check that they all function correctly.

## KDEPLUS BUTTONS

The **KDEPlus** keyboard has 4 keys, as shown in the illustration:







Each key has a different function depending on whether it is:

- Pressed and released
- Pressed for at least 5 seconds
- Pressed and held at start-up
- Pressed in combination with another key.

### KEYS

The following table summarizes the function of each key:

No	Key	Action		
		Pressed and released	Press for at least 5 secs	Start-up
1		<ul style="list-style-type: none"> <li>• Scrolls through menu items</li> <li>• Increases values</li> </ul>	Activates the <b>Manual Defrost function</b> (from outside menus).	---
2		<ul style="list-style-type: none"> <li>• Scrolls through menu items</li> <li>• Decreases values</li> </ul>	Function can be configured by the user (from outside menus). (see parameter H32)	---
3		<ul style="list-style-type: none"> <li>• Returns to the previous menu level</li> <li>• Confirms parameter value</li> </ul>	Activates the Stand-by function (from outside menus).	---
4		<ul style="list-style-type: none"> <li>• Displays any alarms (if active)</li> <li>• Opens Machine Status menu</li> <li>• Confirms commands</li> </ul>	Opens the Programming Menu (User and Installer parameters)	When pressed during start-up it enables the user to select the application to be loaded.

## SETPOINT: SETTING AND EDIT LOCK

To display the Setpoint value, press the **set** key to enter the "Machine Status" menu, then press the **set** key again when the "SEt" label is displayed.

The Setpoint value appears on the display. To change the Setpoint value, press the **▲** and **▼** keys within 15 seconds. Press **set** to confirm the modification.

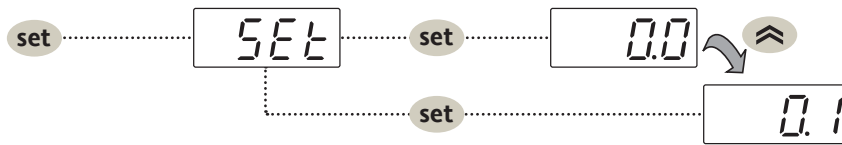

It is possible to disable the keypad on this device.

The keypad can be locked by programming the "LOC" parameter appropriately.

With the keypad locked, you can still access the "Machine Status" menu by pressing **set** to display the Setpoint, but you cannot edit it. To disable the keypad lock, repeat the locking procedure.

## DISPLAY PROBES VALUE

To display the value read by probes connected to the device, press the **set** key and enter the "Machine Status" menu, then press the key again when one of the probe-related labels "Pb1...Pb5" press the **set** key again. The value measured by the associated probe will appear on the display.

**NOTE:** The displayed value is read-only and cannot be modified.

## KEY-ACTIVATED FUNCTIONS

All models have the **UP** key set to enable the "Manual Defrost" function.

The DOWN and ESC keys can also be set to activate any other function required by the user.

The parameters for configuring the two keys are:

- **H11** = DOWN key configuration
- **H33** = ESC key configuration

The values that can be set apply to both keys and the functions that can be activated are:

H32/H33 value	Function to enable
0	disabled
1	defrost
2	reduced set
3	Light
4	Energy saving
5	AUX
6	Stand-by
7	Deep cooling cycle
8	Start/end defrost

## START UP / OPERATION

### START UP

MD4060DA self contained merchandiser has its own evaporator coil and a capillary tube.

- a. Check the interior cabinet thoroughly for loose nuts, bolts and electrical connections.
- b. Inspect the refrigeration lines for visible damage or chafing.
- c. Replace electrical box cover and access panel.
- d. Turn on the electrical power, power switch and start the merchandiser. The merchandiser must pull down in temperature.

**Allow merchandiser 24 hours to operate before loading product.**

### CONTROLS AND ADJUSTMENTS

1. The T-stat controller controls refrigeration temperature. This is factory installed in the control panel. Adjust setpoint on the display to maintain the discharge air temperature shown. Measure discharge air temperatures at the center of the discharge honeycomb.

Defrosts are time initiated and temperature terminated for self contained. The defrost setting is factory set as shown below.

### CONTROLS and ADJUSTMENTS

Refrigeration Controls			Defrost Controls			
Model	Product Application	Discharge Air Temperature	Defrost Frequency (per day)	Type of Defrost	Temp. Termination	Failsafe Time (Minutes)
<b>MD4060DA</b> Self Contained	Medium Temp. (Dairy, Deli)	25°F - 35°F	2	Off Time	48°F	45

## Husmann Self-Contained Refrigeration Equipment Start Up Check List

\*\*\*Please note that failure to follow this start-up document may void your factory warranty\*\*\*

Step	Startup Activity	Check
1	Locate, read and maintain install/operation manual in a safe place for future reference.	<input type="checkbox"/>
2	Examine unit. Confirm there is NO damage or concealed damage.	<input type="checkbox"/>
3	Level the unit, side to side and front to rear.	<input type="checkbox"/>
4	Remove all shipping brackets/compressor straps/bolts etc.	<input type="checkbox"/>
5	Unit must be run on a dedicated electrical circuit without the use of an extension cord.	<input type="checkbox"/>
6	Ensure that the proper electrical requirements for the equipment are supplied.	<input type="checkbox"/>
7	Verify field electrical connections are tight.	<input type="checkbox"/>
8	Verify all electrical wiring is secured and clear of any sharp edges or hot lines.	<input type="checkbox"/>
9	Verify the condensate drain line is properly trapped and pitched.	<input type="checkbox"/>
10	Verify all required clearances on the sides and back of unit.	<input type="checkbox"/>
11	Verify there are no air disturbances external to the unit. Heat and air registers, fans, and doors etc.	<input type="checkbox"/>
<b>Advise owner/operator that merchandiser must operate at temperature for 24 hrs prior to loading with product.</b>		

Form HSCW01 Rev. 30MAY12 P/N 0525209\_B

### LEGAL DISCLAIMER:

Husmann shall not be liable for any repair or replacements made without the written consent of Husmann, or when the product is installed or operated in a manner contrary to the printed instructions covering installation and service which accompanied such product.

## STOCKING

Product should NOT be placed in case until merchandiser is at proper operating temperature. **The MD4060DA merchandisers must remain in operation for at least 24 hours before product may be loaded into case cabinet.** Proper rotation of product during stocking is necessary to prevent product loss. Always bring the oldest product to the front and set the newest to the back.

**AIR EXHAUST AND RETURN GRILLE MUST REMAIN OPEN AND FREE OF OBSTRUCTION AT ALL TIMES.**

Do not allow product, packages, signs, etc. to block air exhaust or return grille. Do not use non-approved shelving, baskets, display racks, or any accessory that could hamper air curtain performance.

## LOAD LIMITS

Product must be within designated load limit to ensure proper refrigeration and air curtain performance.

**AT NO TIME SHOULD MERCHANDISERS BE STOCKED BEYOND THE LOAD LIMITS INDICATED.**



## DO NOT BLOCK AIR LOUVERS.

**At no time should product be stocked:**

- Beyond the front of shelves
- Near the air supply duct located at the top rear of case

**DO NOT LOAD CASE WITH WARM PRODUCT.**

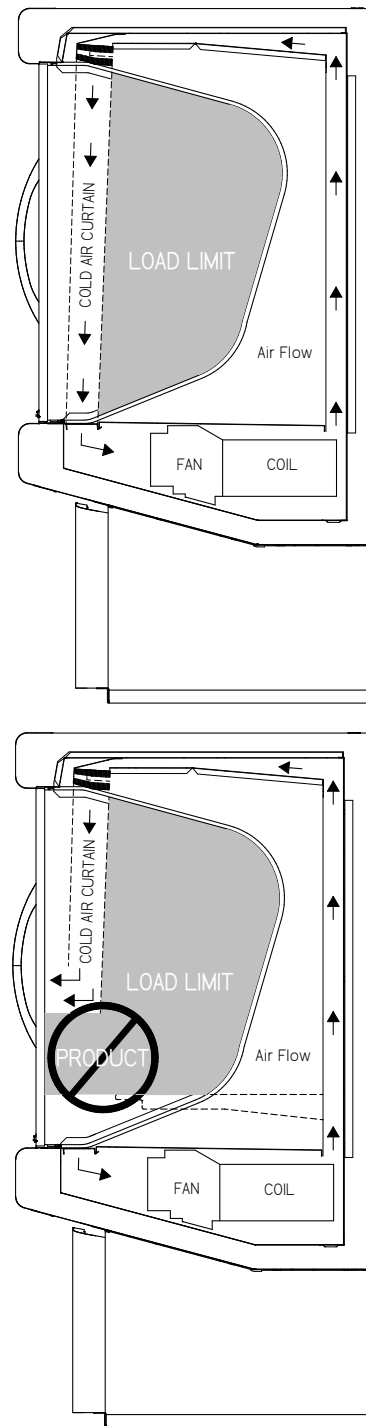

**AIR DISCHARGE AND RETURN FLUES MUST REMAIN OPEN AND FREE OF OBSTRUCTION AT ALL TIMES** to provide proper refrigeration and air curtain performance. Do not allow product, packages, signs, etc. to block these grilles. Do not use non-approved shelving, baskets, display racks, or any accessory that could hamper air curtain performance.

Do not allow product to be placed outside of the designated load limits in the illustration above. Air flows through the back wall, over the product on the shelves, across the face of the product (air curtain), and into the return air grille.

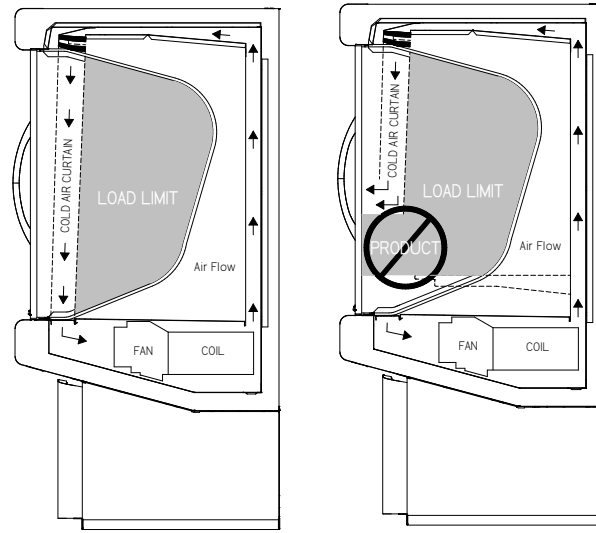

**⚠ WARNING**  
**Product will be degraded and may spoil if allowed to sit in a non-refrigerated area.**

**SHELF MAXIMUM WEIGHT LIMITS**

Hussmann merchandiser shelves are designed to support the maximum weight load limits as indicated in the table below. Exceeding these maximum weight load limits may cause damage to the shelf or shelves, damage to the merchandiser, damage to store products, and potentially create a hazardous condition for customers and staff.

Exceeding the indicated maximum weight load limits constitutes misuse as described in the Hussmann Limited Warranty. MD4060DA has 6 standard, 18 in. shelves for product display.

**Maximum Shelf Weight Limits**

	Flat Shelf load limits at 0° tilt
Bottom Sheet Metal Area	250 lb (113.4 kg)
Standard 18 in Shelf	100lb 45.35kg

## MAINTENANCE

### **WARNING**

To reduce the risk of fire, electrical shock or injury when cleaning this merchandiser:

- **Unplug the merchandiser before cleaning;**
- **Keep all liquids away from electrical and electronic components;**
- **Do not use any mechanical device or other means to speed the defrost process, except as recommended by the manufacturer.**

### CARE AND CLEANING

Long life and satisfactory performance of any equipment is dependent upon the care it receives. To ensure long life, proper sanitation and minimum maintenance costs, this unit should be thoroughly cleaned, all debris removed and the interiors washed down. Cleaning often will control or eliminate odor buildup. Frequency of cleaning is dependent on usage and local health requirements.

### **WARNING**

**Do not use HOT water on COLD glass surfaces. This can cause the glass to shatter and could result in personal injury. Allow glass fronts, ends and service doors to warm before applying hot water.**

### Exterior Surfaces

The exterior surfaces must be cleaned with a mild detergent and warm water to protect and maintain their attractive finish.

**NEVER USE ABRASIVE CLEANERS OR SCOURING PADS. NEVER USE CAUSTIC SODA, KEROSENE, GASOLINE, THINNER, SOLVENTS, DETERGENTS, ACIDS, CHEMICALS OR ABRASIVES. DO NOT USE AMMONIA-BASED CLEANERS ON ACRYLIC PARTS.**

### Interior Surfaces

**DO NOT USE AMMONIA-BASED PRODUCTS TO CLEAN LIGHT SHIELDS. NEVER USE ABRASIVE CLEANSERS OR SCOURING PADS.**

The interior surfaces may be cleaned with most domestic detergents and sanitizing solutions with no harm to the surface. Always read and follow the manufacturer's instructions when using any cleaning product.

### *Do NOT Use:*

- Abrasive cleansers and scouring pads, as these will mar the finish.
- Coarse paper towels on coated glass.
- Ammonia-based cleaners on acrylic parts.
- A hose on lighted shelves or submerge the shelves in water.
- Solvent, oil or acidic based cleaners on any interior surfaces.
- A hose on rail lights, canopy lights or any other electrical connection.

### *Do:*

- **First turn off refrigeration, then disconnect electrical power.**
- Remove product and loose debris.
- Thoroughly clean all surfaces with soap and hot water. **DO NOT USE STEAM OR HIGH WATER PRESSURE HOSES TO WASH THE INTERIOR. THESE DESTROY MERCHANDISER'S SEALING CAUSING LEAKS AND POOR PERFORMANCE.**
- Take care to minimize direct contact between fan motors and cleaning or rinse water.
- Rinse with hot water, but do NOT flood.
- Allow merchandiser to dry before resuming operation.
- Wipe down lighted shelves with a damp sponge or cloth so that water does not enter the light channel. **DO NOT USE A HOSE OR SUBMERGE SHELVES IN WATER.**
- After cleaning is completed, restore power and turn on the merchandiser.



## WARNING

### — LOCK OUT / TAG OUT —

***To avoid serious injury or death from electrical shock, always disconnect the electrical power at the main disconnect when servicing or replacing any electrical component. This includes, but is not limited to, such items as doors, lights, fans, heaters, and thermostats.***

### CLEANING DISCHARGE HONEYCOMB

Discharge air honeycombs should be cleaned every six months. Dirty honeycombs will cause merchandisers to perform poorly. The honeycombs may be cleaned with a vacuum cleaner. Soap and water may be used if all water is removed from the honeycombs cells before replacing. Be careful not to damage the honeycombs.

1. Using a flat object such as a screw driver, compress the honeycomb and remove it from its retainer.
2. Clean and dry the air honeycombs.
3. After cleaning, replace in reverse order. Damaged honeycombs must be replaced.



## CAUTION

### DO NOT FLOOD!

**Use only enough water necessary to clean surface. Water must not drip down the case!**

**Never use ammonia based cleansers, abrasive cleansers, or scouring pads.**

### CLEANING STAINLESS STEEL SURFACES

Use non-abrasive cleaning materials, and always polish with grain of the steel. Use warm water or add a mild detergent to the water and apply with a cloth. Always wipe rails dry after wetting.

Use alkaline chlorinated or non-chlorine containing cleaners such as window cleaners and mild detergents. Do not use cleaners containing salts as this may cause pitting and rusting of the stainless steel finish. Do not use bleach.

### CLEANING SOLAR THERMOMETER

MD4060DA models have solar thermometers. The thermometer is located at the top, front center of the merchandiser's cabinet interior.

To clean the thermometer:

1. Remove the two screws securing the thermometer to its mounting bracket. Remove the sensing element from the clip.
2. Use non-abrasive cleaning materials and a mild detergent to clean thermometer.
3. Be sure to wipe the element clean of any residues.



## CAUTION

**Do NOT use HOT water on Cold glass Surfaces. This can cause the glass to shatter and could result in personal injury. Allow glass fronts, to warm before applying hot water.**

## CLEANING UNDER DISPLAY PAN

Remove all product from the merchandiser and place in cooler. Always disconnect electrical power before cleaning.

1. Remove the display pan
2. Use non-abrasive cleaning materials and a mild detergent to clean display pan.
3. Wipe down the insides of the merchandiser with a mild detergent, and replace display pan. Allow merchandiser to pull down in temperature before loading product

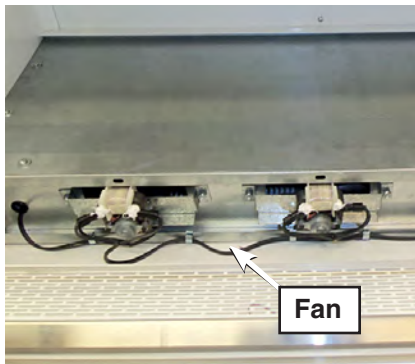

Merchandiser with display pan removed

## CLEANING EVAPORATION PAN

The condensate water outlet for self contained models empties into a limited capacity evaporation pan.

Debris or dirt accumulation inside the condensate evaporation pan or on the heater coil will reduce the pan's evaporation capacity and cause premature heater failure. The evaporation pan waste water will overflow and spill onto the floor if the heater is not properly operating.

Remove accumulated debris from the evaporation pan. Wipe down heater coil with a cloth and warm water. Be sure to remove any dirt, debris or liquids from the heater coil.

Water introduced during cleaning will cause the evaporation pan to overflow.



## WARNING

**Evaporation Pan is Hot!**  
and poses risk of bodily injury – Always wear gloves and protective eye wear when servicing.  
Turn off evaporation pan heater, and allow pan to cool.

## CLEANING COILS

Condenser coils should be cleaned at least once per month. Additional cleaning may be needed depending on the operational environment. A dirty condenser blocks normal airflow through the coils.



### PRECAUTION CLEANING PRECAUTIONS

When Cleaning:

- Do not use high pressure water hoses
- Do not introduce water faster than waste outlet can drain
- NEVER INTRODUCE WATER ON SELF CONTAINED UNIT WITH AN EVAPORATION PAN
- NEVER USE A CLEANING OR SANITIZING SOLUTION THAT HAS OIL BASE (these will dissolve the butyl sealants) or an AMMONIA BASE (this will corrode the copper components of the merchandiser)
- TO PRESERVE THE ATTRACTIVE FINISH:
- Use a water and a mild detergent for the exterior only
- Do NOT use a chlorinated cleaner on any surface
- Do NOT use abrasives or steel wool scouring pads (these will mar the finish)

**NEVER USE SHARP OBJECTS AROUND COILS.** Use a soft brush or vacuum brush to clean debris from coils. *Do not puncture coils!* Do not bend fins. Contact an authorized service technician if a coil is punctured, cracked, or otherwise damaged.

**ICE** in or on the coil indicates the refrigeration and defrost cycle is not operating properly. Contact an authorized service technician to determine the cause of icing, and to make adjustments as necessary. To maintain product integrity, move all product to a cooler until the unit has returned to normal operating temperatures.

Airflow blockage increases energy consumption and reduces the merchandiser's ability to maintain operating temperature.

To clean the coils, use a vacuum cleaner with a wand attachment and a soft (non-metallic) brush to remove dirt and debris. Do not bend coil fins. Always wear gloves and protective eye wear when cleaning near sharp coil fins and dust particles.

### REMOVING SCRATCHES FROM BUMPER

Most scratches and dings can be removed using the following procedure.

1. Use steel wool to smooth out the surface area of the bumper.
2. Clean area.
3. Apply vinyl or car wax and polish surface for a smooth glossy finish.



- Make sure proper cleaning procedures are followed. Lights and fans **MUST** be turned off when a case is cleaned and **MUST** be allowed to dry before turning power back on.
- Do not use a pressure nozzle to clean inside of case.



### ADJUSTING CLOSING TORQUE

Adjust closing torque by turning the bottom hinge pin in the direction the door closes. Use a  $\frac{1}{2}$  in. (13 mm) wrench. Turn the hinge pin until the door closes on its own, usually 2 to 3 clicks or  $\frac{3}{4}$  turn.

**DO NOT** over-torque the hinge spring assembly. Excessive torque (over 1 full turn) will result in damage to the spring assembly and/or door. If door does not close on its own after one full turn (5 clicks), look for obstructions causing the door to hang up.

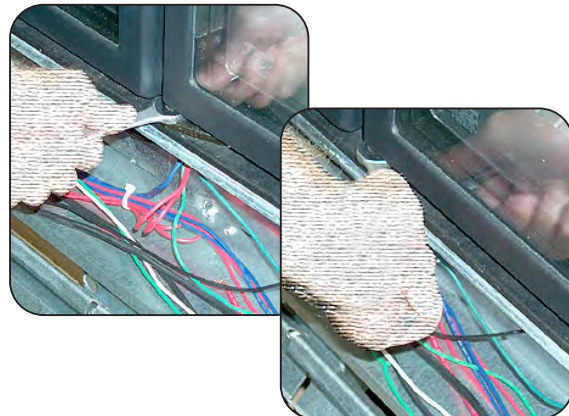

Adjusting Closing Torque

### Self-Contained Refrigeration Equipment Maintenance Check List

***** Warranty does not cover issues caused by improper installation or lack of basic preventative maintenance. *****											
Record starting date											
Store Name and Number											
Store Address											
Unit Model Number											
Unit Serial Number											
Contractor/Technician											
	Technician										
	PM date										
PM activity-For visual inspection items, denote "ok or complete" in the column to right when PM has been performed. For measured data requested, record data requested in the appropriate column to the right)	Quarterly	Semi-Annually	Q1	Q2	Q3	Q4	Q1	Q2	Q3	Q4	
Check in with store manager, record any complaints or issues they have with unit.	X										
Look unit over for any damage, vibrations or abnormal noise.	X										
Verify unit is level side to side and front to rear.	X										
Confirm refrigerant lines properly are secured and not touching or rubbing other lines, wires or frame work.	X										
Verify fan motors and motor mounts are tight.	X										
Confirm fan blade/s are tight and not rubbing or hitting.	X										
Make sure all electrical connections, factory and field, are tight.	X										
Verify electrical connections at lamps are they secure and dry.	X										
Check for and replace any frayed or chaffed wiring.	X										
Check all electrical wiring make sure it is secured and not on any sharp edges or hot lines.	X										
Check for air disturbances external to the unit. Heat and air registers, fans, and doors etc.	X										
Check for water leaks.	X										
Clean evaporator coil/s and fan blade/s. Do not use an acid base cleaner. Rinse off any cleaner residue.		X									
Clean discharge air honeycombs or grilles. Do not use an acid base cleaner. Rinse off any cleaner residue.		X									
Clean condenser coil/s and fan blade/s. Do not use an acid base Cleaner. Rinse off any cleaner residue.		X									
Clean condensate drain pan and drain line.		X									
Verify condensate drain lines are clear and functioning.		X									
Record voltage reading at unit with unit off?		X									
Verify condenser and evaporator fans are working.	X										
Record condenser air inlet temperature	X										
Record condenser air outlet temperature	X										
Is condenser air inlet or air exhaust restricted or recirculating?	X										
Use a handheld propane leak detector ("sniffer") to check for refrigerant leaks.	X										
Record voltage reading with unit running.		X									
Record compressor amp draw.		X									
Record defrost heater voltage and amp draw.		X									
Record anti-sweat heater voltage and amp draw.		X									
Record case product temperature.	X										
Record unit discharge air temperature.	X										
Record unit return air temperature.	X										
Record ambient conditions around unit (wet Bulb temperature and dry bulb temperature).	X										
Check product loading, do not load beyond the units load limits.	X										
Verify clearances on sides/back of unit.	X										
Check unit controller for proper operation. See controller or 1/0 Manual for proper controller operation.		X									
Confirm door switches function.	X										
Verify unit doors and lids work and are sealed correctly.	X										
Verify that all the panels, shields and covers are in place.	X										

Technician Notes:

Form HSCW03 Rev-29 OCTOBER13

Maintenance Notes:

## SERVICE

### REPLACING FAN MOTORS AND BLADES

Should it ever be necessary to service or replace the fan motors or blades be certain that the fan blades are reinstalled correctly. **THE BLADES MUST BE INSTALLED WITH RAISED EMBOSING (PART NUMBER ON PLASTIC BLADES) POSITIONED AS INDICATED ON THE PARTS LIST.**

#### For access to these fans:

1. Remove product and place in a refrigerated area. Disconnect electrical power.
2. Remove bottom pan.
3. **Disconnect fan from wiring harness.**
4. If it is determined that fan motor needs to be replaced, remove fan motor brackets from the fan plenum as shown.
5. Replace fan motor and/or blades.
6. Install brackets to fan motor and motor bracket to the fan plenum.
7. Reconnect fan motor to wiring harness.
8. Turn on power.
9. Verify that motor is working and blade is turning in the correct direction.
10. Reinstall display pans. Bring merchandiser to operating temperature before restocking.

## WARNING

**Product will be degraded and may spoil if allowed to sit in a non-refrigerated area.**

## WARNING

**— LOCK OUT / TAG OUT —**

***To avoid serious injury or death from electrical shock, always disconnect the electrical power at the main disconnect when servicing or replacing any electrical component. This includes, but is not limited to, such items as doors, lights, fans, heaters, and thermostats.***

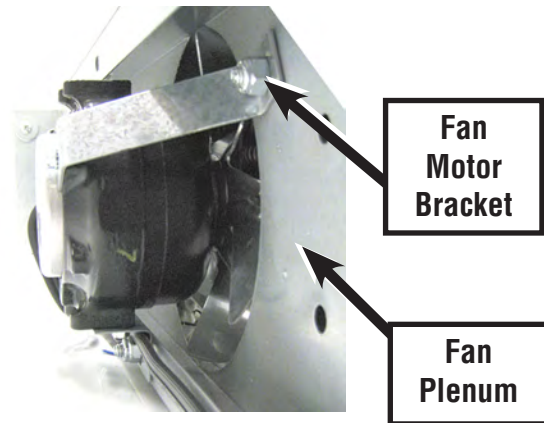

### CLEANING COILS

***NEVER USE SHARP OBJECTS AROUND COILS. Use a soft brush or vacuum brush to clean debris from coils. Do not puncture coils!*** Do not bend fins. Contact an authorized service technician if a coil is punctured, cracked, or otherwise damaged.

**ICE** in or on the coil indicates the refrigeration and defrost cycle is not operating properly. Contact an authorized service technician to determine the cause of icing and to make adjustments as necessary. To maintain product integrity, move all product to a cooler until the unit has returned to normal operating temperatures.

## LED LIGHT REPLACEMENT

1. Remove stainless steel screws from the door as shown in the illustration.
2. Carefully open the doors, and avoid touching the acrylic sides.
3. Twist door closer arms 90° as shown in the illustration. (Do not open door closer more than 90° this could damage the system).
4. Keep both door systems open. (This must be performed by two technicians.)
5. Rotate the LED fixture to release it from the lamp holder.
6. Change LED light, and replace with like fixture.

## REPLACING SOLAR THERMOMETER

MD4060DA models have solar thermometers. The thermometer is located at the top, front center of the merchandiser's cabinet interior.

Temperature is displayed in Fahrenheit degrees as a standard option. Celsius is also an available option. The thermometer may be replaced if it becomes damaged.

To replace: remove the two screws securing the thermometer to its mounting bracket. Remove the sensing element from the clip, and install the new thermometer in reverse order.

Top connection for LED



Bottom of LED

## REMOVING AND REPLACING DOORS

1. Open the door 90°.



2. Look for the hinge on the bottom of the door.



3. Use a flat screwdriver to lift the hinge



4. Once the hinge is out of its place, remove the door. Replace with new door and assembly in the opposite order.



## TROUBLESHOOTING GUIDE

PROBLEM	PROBABLE CAUSE	SOLUTION
Compressor will not start. (no noise)	<ol style="list-style-type: none"> <li>1. Power disconnected</li> <li>2. Blown fuse or breaker</li> <li>3. Defective or broken wiring</li> <li>4. Defective overload</li> <li>5. Defective temperature control</li> </ol>	<ol style="list-style-type: none"> <li>1. Check service cord or wiring connection</li> <li>2. Replace fuse or reset breaker</li> <li>3. Repair or replace</li> <li>4. Replace</li> <li>5. Replace</li> </ol>
Compressor will not start; cuts out on overload.	<ol style="list-style-type: none"> <li>1. Low voltage</li> <li>2. Defective compressor</li> <li>3. Defective relay</li> <li>4. Restriction (pinched cap tube)</li> <li>5. Restriction (moisture)</li> <li>6. Condenser blocked with dust and dirt</li> <li>7. Defective condenser fan motor</li> </ol>	<ol style="list-style-type: none"> <li>1. Cabinet voltage must not be more than 5% below rating</li> <li>2. Replace</li> <li>3. Replace</li> <li>4. Repair or replace</li> <li>5. Leak check, replace drier evacuate and recharge</li> <li>6. Clean condenser</li> <li>7. Replace</li> </ol>
Warm storage temperature	<ol style="list-style-type: none"> <li>1. Temperature control not set properly</li> <li>2. Short or refrigerant</li> <li>3. Cabinet location too warm</li> <li>4. Refrigerant over-charge</li> <li>5. Low voltage, compressor cycling on overload</li> </ol>	<ol style="list-style-type: none"> <li>1. Reset control. Rotate knob Clockwise</li> <li>2. Leak check, replace drier evacuate and recharge</li> <li>3. Move to cooler location or correct excessive heat source</li> <li>4. Purge system, evacuate and recharge</li> <li>5. Compressor voltage must not be more than 5% below rating</li> </ol>
Compressor runs continuously; product too warm.	<ol style="list-style-type: none"> <li>1. Short of refrigerant</li> <li>2. Inefficient compressor</li> <li>3. Coil iced up</li> </ol>	<ol style="list-style-type: none"> <li>1. Leak check, replace drier, evacuate and recharge</li> <li>2. Replace</li> <li>3. Force manual defrost</li> </ol>
Compressor runs continuously; product too cold	<ol style="list-style-type: none"> <li>1. Defective control</li> <li>2. Control sensing element not in positive contact</li> <li>3. Short on refrigerant</li> </ol>	<ol style="list-style-type: none"> <li>1. Replace</li> <li>2. Assure proper contact</li> <li>3. Leak check, replace drier evacuate and recharge</li> </ol>

**TROUBLESHOOTING LIGHT GUIDE**

PROBLEM	SOLUTION
Lights won't start	<ol style="list-style-type: none"> <li>1. Check light switch</li> <li>2. Check continuity to ballast / Power Supply</li> <li>3. Check to see if bulbs are inserted properly in sockets</li> <li>4. Check voltage</li> </ol>
Lights flicker	<ol style="list-style-type: none"> <li>1. Allow lamps to warm up</li> <li>2. Check lamp sleeve for cracks</li> <li>3. Check sockets for moisture and proper contact</li> <li>4. Bulb replacement may be necessary</li> <li>5. Check voltage</li> <li>6. New bulbs tend to flicker until used</li> </ol>

**Visual Description of R290 Replacement Parts**



**Main Switch**



**Light Switch**



**Solid State Relay 10 Amp**



**Control RTN400**



**Control Display KDE**

## MD4060DA Replacement Parts List

MD4060DA	
Standard Parts	
Description	Part Number
Power Cord (NEMA 5-25P)	0521094
Sensor NTC 4 mts green	3023554
Sensor NTC 4 mts orange	3031571
Control Eliwell RTN400	3023537
Control Display KDE	3023552
Main/Light Switch 15 Amp	3038707
Solid State Relay 10 Amp	3025471
Led Light LH 4000K	3036131
Led Light RH 4000K	3036134
Power Supply 100W 24VDC	3013744
Door LH 18x30	3031621
Door RH 18x30	3031622
Hinge Assy LH	3031619
Hinge Assy RH	3031620
End glass LH	3032271
End glass RH	3032272
Trim End Glass Black	0539061
PTM 27.5 IN	3013771

MD4060DA	
Refrigeration	
Compressor R290 208V/60Hz	3024061
Condenser	3020001
Condenser Fan Motor Assy (Motor, Blade & Brkt)	0548144
Evaporator Coil	0556923
Evaporator Fan Motor	0530147
Evaporator Fan Blade	0519568
Evaporator Fan Motor Bracket	0210201
Capillary Tube .042" x 84"	3032277
Filter Drier 704-200	0530462

MD4060DA	
Sheet Metal Replacement Parts Painted	
Front Grill Access Assy	3032631
Rear Grill	3032711
Bumper Top	3033041
Bumper Bottom	3033042
Cover End Glass LH	3032710
Cover End Glass RH	3033266
Shelf Assy 18x18 in Black	3032744
Cover Interior Bottom	0557116
Panel Interior Back	0557132
Shelf Post Ends	0557134
Shelf Post Center	0557142

### WARNING

**Component parts are specifically chosen for propane exposure and therefore non-incident and non-sparking. Component parts shall be replaced with identical components, and servicing shall be done by factory authorized service personnel only, so as to minimize the risk of possible ignition due to incorrect parts or improper service.**

**MD4060DA**

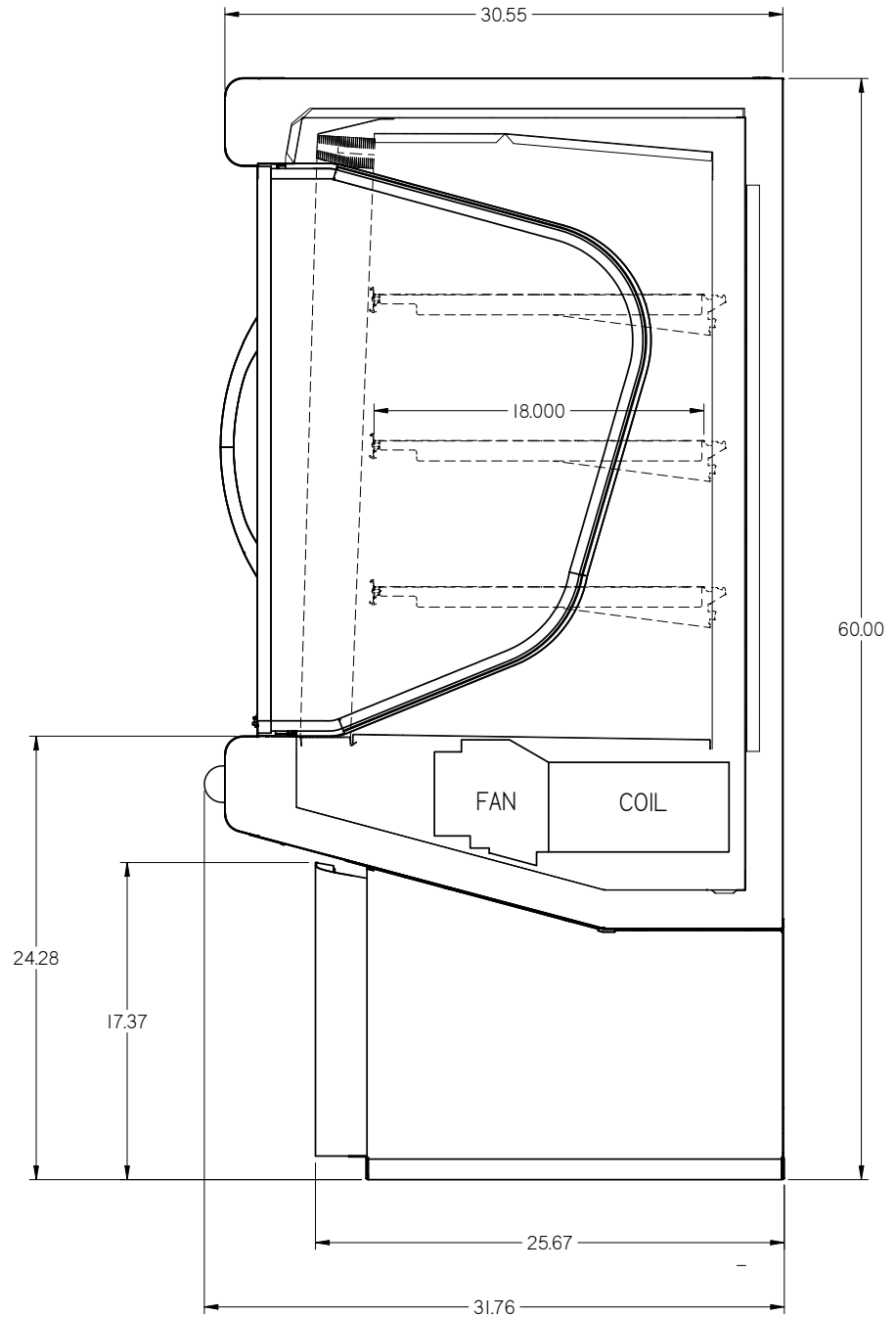

**General**

**MD4060DA**

Case Length ( <i>Note: Includes One Pair Ends</i> )	40 in. (1016 mm)
Optional End Bumpers ( <i>One Pair</i> )	2 in. (51 mm)

**Waste Outlet**

LH end of case ( <i>from outside of End Assembly</i> ) to center of waste outlet	20 in. (508 mm)
---	-----------------

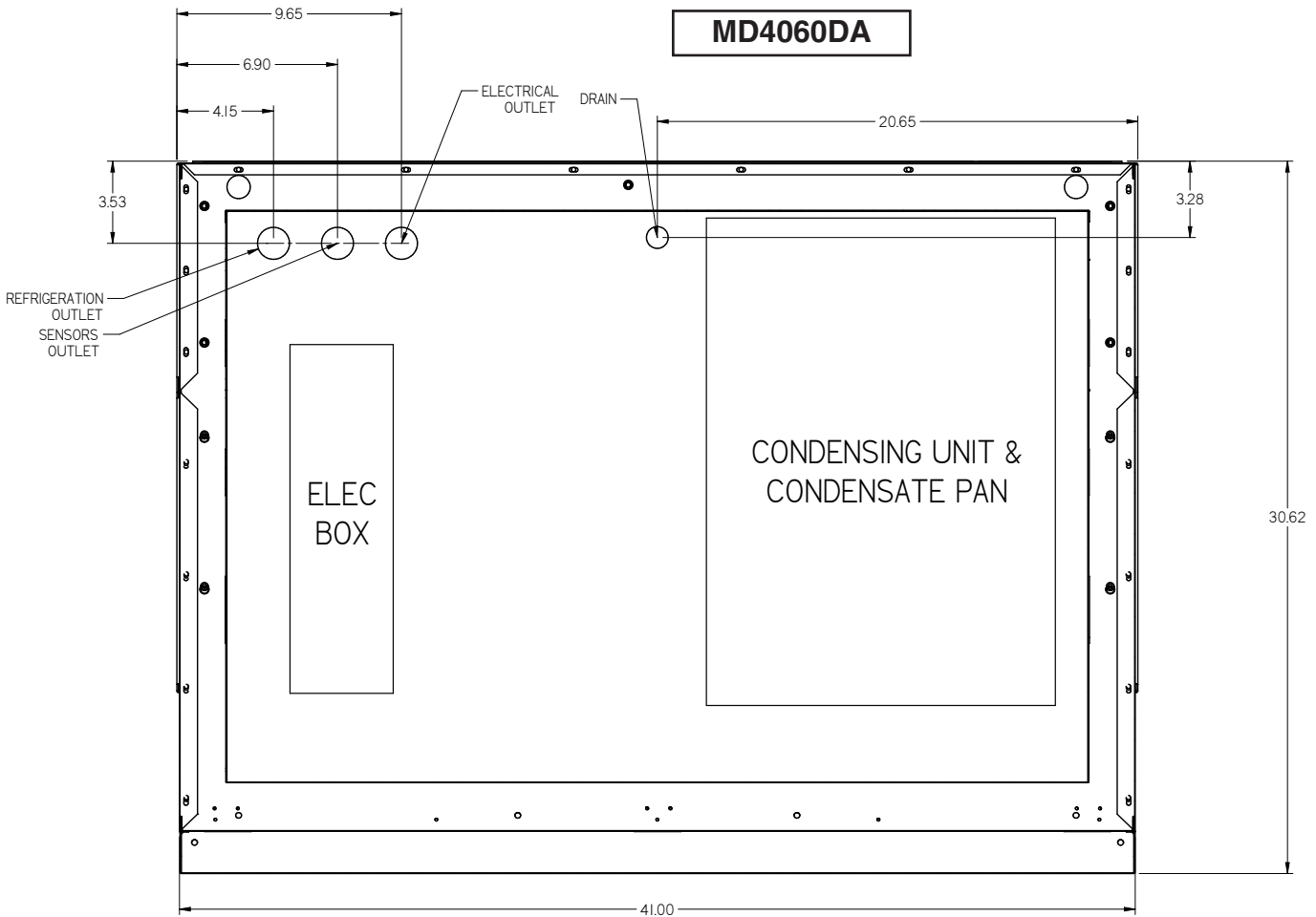

Dimensions shown as inches and (mm).

SECTION B-B

**REFRIGERATION DATA**

**DEFROST DATA**

**MD4060DA**

**Frequency (hour)**

MD4060DA 12

**Thermostat**

**Tripping Differential**

MD4060DA 7° F

**OFFTIME**

**Failsafe (minutes)**

MD4060DA 45

**Condensing Unit**

**Capacity**

MD4060DA 2399

**Defrost Termination**

Temperature Terminated 48° F

(Btu per hour at std. rating conditions)

**PHYSICAL DATA**

**Refrigerant Charge**

MD4060DA (R290) 5.3 oz 0.150 kg

**Note:** This data is based on store temperature and humidity that does not exceed 80°F and 55% R.H. unless otherwise stated. Schedule defrost at night while lights are off.

**Electrical Data**

*Note: These are rated values for individual components and should not be added together to determine total merchandiser electrical load.*

MD4060DA

**Number of Fans – 4W (EC Motor)****2****Amperes    Watts****Evaporator Fans**

115V 60Hz

**0.12****4****Condensing Unit (115V, 1Ph, 60Hz) Standard**

MD4060DA

Compressor LRA

37

Compressor RLA

4.6

**Product Data**

MD4060DA

*AHRI Total Display Area<sup>1</sup> (Sq Ft/Case)*10.75 ft<sup>2</sup> /case ( .99 m<sup>2</sup> /case)<sup>1</sup> Computed using AHRI 1200 standard methodology:Total Display Area, ft<sup>2</sup> [m<sup>2</sup>] / Unit of Length, ft [m]

<b>MD4060DA</b>	Refrigerant Type	Volts	Run Amps	Nema Plugs	Fuse Amps	Hz/Ph
	R290	115	1.83	5-15P	15	60/1

**ESTIMATED SHIPPING WEIGHT <sup>2</sup>**

<i>Self Contained</i>	<i>Case</i>	<i>with Shipping Crate</i>	<i>End</i>
MD4060DA	<b>434 lb</b> (197kg)	<b>520 lb</b> (236kg)	Included

<sup>2</sup> Actual weights will vary according to optional kits included.

**MD4060DA WIRING DIAGRAM**

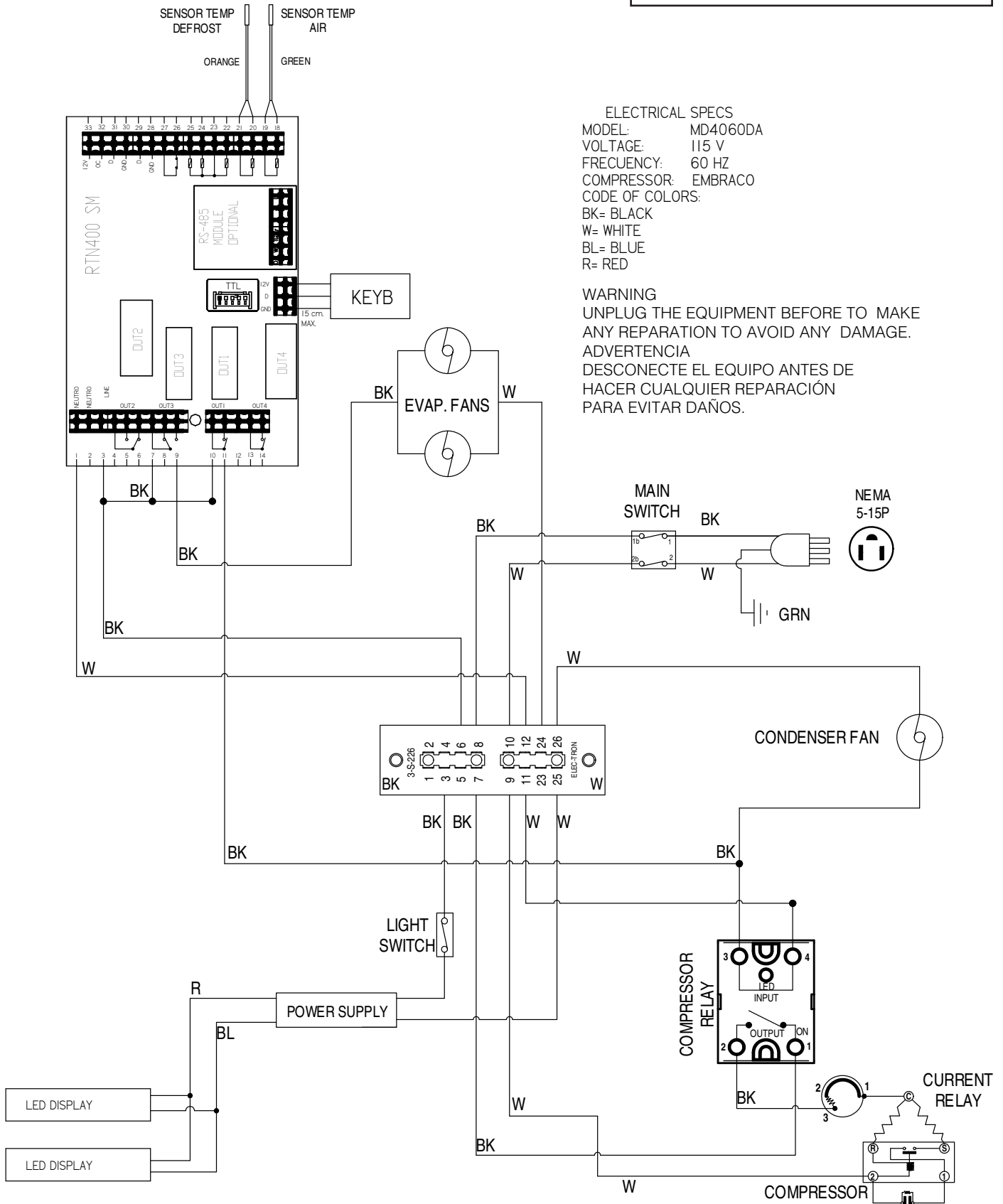

ELECTRICAL SPECS  
 MODEL: MD4060DA  
 VOLTAGE: 115 V  
 FREQUENCY: 60 HZ  
 COMPRESSOR: EMBRACO  
 CODE OF COLORS:  
 BK= BLACK  
 W= WHITE  
 BL= BLUE  
 R= RED

WARNING  
 UNPLUG THE EQUIPMENT BEFORE TO MAKE ANY REPARATION TO AVOID ANY DAMAGE.  
 ADVERTENCIA  
 DESCONECTE EL EQUIPO ANTES DE HACER CUALQUIER REPARACIÓN PARA EVITAR DAÑOS.



# **HUSSmann®**

**To obtain warranty information  
or other support, contact your  
Hussmann representative.  
Please include the model and  
serial number of the product.**

*Hussmann Corporation, Corporate Headquarters: Bridgeton, Missouri, U.S.A. 63044-2483*